

**P C600**  
**Machine Code: M0CJ**  
**Field Service Manual**  
**Ver 1.0**

**Latest Release: May, 2019**  
**Initial Release: May, 2019**  
**(c) 2019 Ricoh Co.,Ltd.**



# Important Safety Notices

---

## Warnings, Cautions, Notes

---

In this manual, the following important symbols and notations are used.

### **WARNING**

- A Warning indicates a potentially hazardous situation. Failure to obey a Warning could result in death or serious injury.

### **CAUTION**

- A Caution indicates a potentially hazardous situation. Failure to obey a Caution could result in minor or moderate injury or damage to the machine or other property.

### **Important**

- Obey these guidelines to avoid problems such as misfeeds, damage to originals, loss of valuable data and to prevent damage to the machine.

### **Note**

- This information provides tips and advice about how to best service the machine.

---

## General Safety Instructions

---

For your safety, please read this manual carefully before you use this product. Keep this manual handy for future reference.

### **Safety Information**

Always obey the following safety precautions when using this product.

### **Safety During Operation**

In this manual, the following important symbols and notations are used.

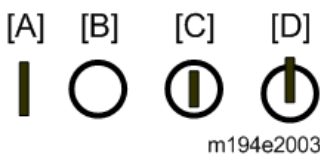

[A]: ON

[B]: OFF

[C]: Push ON/Push OFF

[D]: Standby

### **Switches and Symbols**

Where symbols are used on or near switches on machines for Europe and other areas, the meaning of each symbol conforms with IEC60417.

---

## Safety

---

### Prevention of Physical Injury

---

1. Before disassembling or assembling parts of the machine and peripherals, make sure that the machine and peripheral power cords are unplugged.
2. The plug should be near the machine and easily accessible.
3. Note that some components of the machine and the paper tray unit are supplied with electrical voltage even if the main power switch is turned off.
4. Always unplug the power cord from the power source before you move the product. Before you move the machine, arrange the power cord so it will not fall under the machine.
5. Disconnect all peripheral units (finisher, LCT, etc.) from the mainframe before you move the machine.
6. If any adjustment or operation check has to be made with exterior covers off or open while the main switch is turned on, keep hands away from electrified or mechanically driven components.
7. The machine drives some of its components when it completes the warm-up period. Be careful to keep hands away from the mechanical and electrical components as the machine starts operation.
8. The inside and the metal parts of the fusing unit become extremely hot while the machine is operating. Be careful to avoid touching those components with your bare hands.
9. To prevent a fire or explosion, keep the machine away from flammable liquids, gases, and aerosols.
10. Do not use flammable sprays or solvent in the vicinity of the machine. Also, avoid placing these items in the vicinity of the machine. Doing so could result in fire or electric shock.
11. To avoid fire or explosion, never use an organic cleaner near any part that generates heat.
12. Clean the floor completely after accidental spillage of silicone oil or other materials to prevent slippery surfaces that could cause accidents leading to hand or leg injuries.
13. Never remove any safety device unless it requires replacement. Always replace safety devices immediately.
14. Never do any procedure that defeats the function of any safety device.
15. Modification or removal of a safety device (fuse, switch, etc.) could lead to a fire and personal injury. Always test the operation of the machine to ensure that it is operating normally and safely after removal and replacement of any safety device.
16. For replacements use only the correct fuses or circuit breakers rated for use with the machine. Using replacement devices not designed for use with the machine could lead to a fire and personal injuries.
17. For machines installed with the ADF/ARDF:  
When a thick book or three-dimensional original is placed on the exposure glass and the ARDF cover is lowered, the back side of the ARDF rises up to accommodate the original. Therefore, when closing the ARDF, please be sure to keep your hands away from the hinges at the back of the ARDF.
18. When using a vacuum cleaner around the machine, keep others away from the cleaner, especially

small children.

19. For machines installed with the anti-tip components:

The anti-tip components are necessary for meeting the requirements of IEC60950-1, the international standard for safety. The aim of these components is to prevent the products, which are heavy in weight, from toppling as a result of people running into or leaning onto the products, which can lead to serious accidents such as persons becoming trapped under the product. (U.S.: UL60950-1, Europe: EN60950-1) Therefore, removal of such components must always be with the consent of the customer. Do not remove them at your own judgment.

20. **NEVER touch** the AC circuits on the PSU board to prevent electric shock caused by residual charge. Residual charge of about 100V-400V remains in the AC circuits on the PSU board for several months even when the board has been removed from the machine after turning off the machine power and unplugging the power cord.

### Health Safety Conditions

---

1. For the machines installed with the ozone filters:
  - Never operate the machine without the ozone filters installed.
  - Always replace the ozone filters with the specified types at the proper intervals.
2. The machine, which use high voltage power source, can generate ozone gas. High ozone density is harmful to human health. Therefore, locate the machine in a large well ventilated room that has an air turnover rate of more than 50m<sup>3</sup>/hr/person.
3. Toner and developer are non-toxic, but if you get either of them in your eyes by accident, it may cause temporary eye discomfort. Try to remove with eye drops or flush with water as first aid. If unsuccessful, get medical attention.

### Observance of Electrical Safety Standards

---

1. The machine and its peripherals must be installed and maintained by a customer service representative who has completed the training course on those models with exceptions on some machines where the installation can be handled by the user.

### Safety and Ecological Notes for Disposal

---

- Do not incinerate toner bottles or used toner. Toner dust may ignite suddenly when exposed to an open flame.
- Dispose of used toner, developer, organic photoconductors, and AIO unit in accordance with local regulations. (These are non-toxic supplies.)
- Dispose of replaced parts in accordance with local regulations.
- When keeping used lithium batteries in order to dispose of them later, do not put more than 100 batteries per sealed box. Storing larger numbers or not sealing them apart may lead to chemical reactions and heat build-up.

### **CAUTION**

The danger of explosion exists if a battery of this type is incorrectly replaced. Replace only with the same or an equivalent type recommended by the manufacturer. Discard used batteries in accordance with the manufacturer's instructions.

## Handling Toner

---

- Work carefully when removing paper jams or replacing toner bottles or cartridges to avoid spilling toner on clothing or the hands.
- If toner is inhaled, immediately gargle with large amounts of cold water and move to a well-ventilated location. If there are signs of irritation or other problems, seek medical attention.
- If toner gets on the skin, wash immediately with soap and cold running water.
- If toner gets into the eyes, flush the eyes with cold running water or eye wash. If there are signs of irritation or other problems, seek medical attention.
- If toner is swallowed, drink a large amount of cold water to dilute the ingested toner. If there are signs of any problem, seek medical attention.
- If toner spills on clothing, wash the affected area immediately with soap and cold water. Never use hot water! Hot water can cause toner to set and permanently stain fabric.
- Always store toner and developer supplies such as toner and developer packages, cartridges, bottles (including used toner and empty bottles and cartridges), and AIO unit out of the reach of children.
- Always store fresh toner supplies or empty bottles or cartridges in a cool, dry location that is not exposed to direct sunlight.
- Do not use a vacuum cleaner to remove spilled toner (including used toner). Vacuumed toner may cause a fire or explosion due to sparks or electrical contact inside the cleaner. However, it is possible to use a cleaner designed to be dust explosion-proof. If toner is spilled over the floor, sweep up spilled toner slowly and clean up any remaining toner with a wet cloth.

## Handling the development unit cooling system

---

For the machines installed the development cooling system:

1. The development unit cooling system circulates propylene glycol from a sealed tank through hoses that pass behind cooling plates on the sides of each development unit.
2. The coolant tank is located at the bottom of the cooling box on the back of the main machine.
3. Always obey local laws and regulations if you need to dispose of a tank or the propylene glycol coolant.
4. The tank must never be emptied directly into a local drainage system, river, pond, or lake.
5. Contact a professional industrial waste disposal organization and ask them to dispose of the tank.

## Lithium Batteries for Taiwan

---

### 警告

本機器內的鋰電池如果更換不正確型號會有爆炸的危險。  
只能使用相同或製造商推薦同等類型的電池進行更換。  
請依製造商說明書處理用過之廢棄電池。

---

## Laser Safety

---

The Center for Devices and Radiological Health (CDRH) prohibits the repair of laser-based optical units in the field. The optical housing unit can only be repaired in a factory or at a location with the requisite equipment. The laser subsystem is replaceable in the field by a qualified Customer Engineer. The laser chassis is not repairable in the field. Customer engineers are therefore directed to return all chassis and laser subsystems to the factory or service depot when replacement of the optical subsystem is required.

### **⚠ WARNING**

- Use of controls, or adjustment, or performance of procedures other than those specified in this manual may result in hazardous radiation exposure.

**WARNING FOR LASER UNIT**

**WARNING:**

Turn off the main switch before attempting any of the procedures in the Laser Unit section. Laser beams can seriously damage your eyes.

\_safe006

\_safe007

\_safe008

---

## Safety Instructions for the Color Controller

---

### Fuse

The color controller uses a double pole fuse. If this fuse blows, be sure to replace it with an identical fuse.

### Batteries

### **⚠ CAUTION**

Always replace a battery with the same type of battery prescribed for use with the color controller unit. Replacing a battery with any type other than the one prescribed for use could cause an explosion.

- Never discard used batteries by mixing them with other batteries or other refuse.
- Always remove used batteries from the work site and dispose of them in accordance with local laws and regulations regarding the disposal of such items.



# Symbols, Abbreviations and Trademarks











---

## Symbols, Abbreviations

---

This manual uses several symbols and abbreviations.

### Symbols:

Symbol	What it means
	Clip ring
	Screw
	Connector
	Clamp
	E-ring
	Flat Flexible Cable
	Timing Belt
SEF	Short Edge Feed
LEF	Long Edge Feed
K	Black
C	Cyan
M	Magenta
Y	Yellow
B/W, BW	Black and White
FC	Full color
	Location of the screw(s) to be unscrewed or loosen
	Location of the connector(s), clamp(s) or spring(s) to be removed
	Direction (Rotating or moving)

### Abbreviations:

 **Note**

Abbreviations such as (M1), (S1), or (TH1) attached after the name of some electrical components show the symbols in Point-to-Point diagram.

Abbreviation	Meaning
SEF	Short Edge Feed
LEF	Long Edge Feed

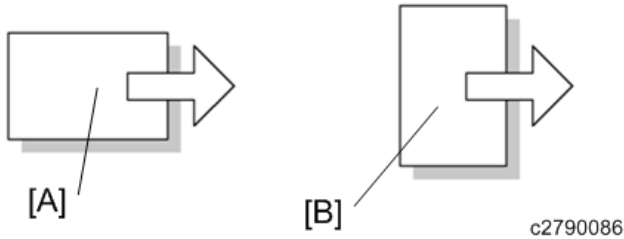

[A] Short Edge Feed (SEF)

[B] Long Edge Feed (LEF)

---

## Trademarks

---

Adobe, Acrobat, PageMaker, PostScript, and PostScript 3 are either registered trademarks or trademarks of Adobe Systems Incorporated in the United States and/or other countries.

The Bluetooth® word mark and logos are registered trademarks owned by Bluetooth SIG, Inc. and any use of such marks by Ricoh Company, Ltd. is under license.

Firefox and Thunderbird are registered trademarks of the Mozilla Foundation.

Google, Android, and Chrome are trademarks of Google Inc.

iOS® is a registered trademark or trademark of Cisco Systems, Inc. and/or its affiliates in the United States and certain other countries.

Java is a registered trademark of Oracle and/or its affiliates.

JAWS® is a registered trademark of Freedom Scientific, Inc., St. Petersburg, Florida and/or other countries.

Kerberos is a trademark of the Massachusetts Institute of Technology (MIT).

Linux is a registered trademark of Linus Torvalds.

Macintosh, OS X, Bonjour, Safari, and TrueType are trademarks of Apple Inc., registered in the U.S. and other countries.

Microsoft, Windows, Windows Server, Windows Vista, Internet Explorer, and Outlook are either registered trademarks or trademarks of Microsoft Corp. in the United States and/or other countries.

PictBridge is a trademark.

QR Code is a registered trademark of DENSO WAVE INCORPORATED in Japan and in other countries.

"Red Hat" is a registered trademark of Red Hat, Inc.

The SD and SD logo are trademarks of SD-3C, LLC.

UNIX is a registered trademark of The Open Group.

UPnP is a trademark of UPnP Implementers Corporation.



This product includes RSA BSAFE® Cryptographic software of EMC Corporation. RSA and BSAFE are registered trademarks or trademarks of EMC Corporation in the United States and other countries.

The proper names of Internet Explorer 6, 7, and 8 are as follows:

- Microsoft® Internet Explorer® 6
- Windows® Internet Explorer® 7
- Windows® Internet Explorer® 8

The proper names of the Windows operating systems are as follows:

- The product names of Windows Vista are as follows:

Microsoft® Windows Vista® Ultimate

Microsoft® Windows Vista® Business

Microsoft® Windows Vista® Home Premium

Microsoft® Windows Vista® Home Basic

Microsoft® Windows Vista® Enterprise

- The product names of Windows 7 are as follows:

Microsoft® Windows® 7 Home Premium

Microsoft® Windows® 7 Professional

Microsoft® Windows® 7 Ultimate

Microsoft® Windows® 7 Enterprise

- The product names of Windows 8 are as follows:

Microsoft® Windows® 8

Microsoft® Windows® 8 Pro

Microsoft® Windows® 8 Enterprise

- The product names of Windows 8.1 are as follows:

Microsoft® Windows® 8.1

Microsoft® Windows® 8.1 Pro

Microsoft® Windows® 8.1 Enterprise

- The product names of Windows 10 are as follows:

Microsoft® Windows® 10 Home Premium

Microsoft® Windows® 10 Pro

Microsoft® Windows® 10 Enterprise

Microsoft® Windows® 10 Education

- The product names of Windows Server 2003 are as follows:

Microsoft® Windows Server® 2003 Standard Edition

Microsoft® Windows Server® 2003 Enterprise Edition

- The product names of Windows Server 2003 R2 are as follows:

Microsoft® Windows Server® 2003 R2 Standard Edition

Microsoft® Windows Server® 2003 R2 Enterprise Edition

- The product names of Windows Server 2008 are as follows:

Microsoft® Windows Server® 2008 Standard

Microsoft® Windows Server® 2008 Enterprise

- The product names of Windows Server 2008 R2 are as follows:

Microsoft® Windows Server® 2008 R2 Standard

Microsoft® Windows Server® 2008 R2 Enterprise

- The product names of Windows Server 2012 are as follows:

Microsoft® Windows Server® 2012 Foundation

Microsoft® Windows Server® 2012 Essentials

Microsoft® Windows Server® 2012 Standard

- The product names of Windows Server 2012 R2 are as follows:

Microsoft® Windows Server® 2012 R2 Foundation

Microsoft® Windows Server® 2012 R2 Essentials

Microsoft® Windows Server® 2012 R2 Standard

Other product names used herein are for identification purposes only and might be trademarks of their respective companies. We disclaim any and all rights to those marks.

Microsoft product screen shots reprinted with permission from Microsoft Corporation.

# Table of Contents

1. Product Information.....	7
Product Overview .....	7
Machine Codes and Peripherals Configuration .....	8
Main Machine .....	8
Options .....	8
Specifications .....	10
2. Installation.....	11
Installation Requirements .....	11
Environment.....	11
Machine Level.....	12
Minimum Space Requirements .....	12
Machine Dimensions.....	12
Power Requirements .....	13
Main Machine Installation .....	14
Installation Flowchart .....	14
Accessory Check .....	14
Installation Procedure .....	15
Settings According to the Service Contract.....	15
Moving the Machine.....	16
Transporting the Machine .....	16
Paper Feed Unit PB1150 (M544) .....	18
Accessory Check .....	18
Installation Procedure .....	18
Hard Disk Drive Option Type P17 (M547-01) .....	19
Accessory Check .....	19
Installation Procedure .....	19
Enhanced Security HDD Option Type M10 (D792-09) .....	20
Accessory Check .....	20
Installation Procedure .....	21
Internal Options .....	25
List of Slots .....	25
IEEE 1284 Interface Board Type M19 (D3C0-17) .....	26
Accessory Check .....	26
Installation Procedure .....	26
IEEE 802.11 Interface Unit Type M24 (M500-08).....	27
Accessory Check .....	27
Installation Procedure .....	27

USB Device Server Option Type M19 (D3BC-28, 29)	28
Accessory Check	28
Installation Procedure	28
SD Card Options	34
SD Card Slots	34
SD Card Appli Move	35
Overview	35
SD Card Appli Move	36
Move Exec	37
Undo Exec	37
XPS Direct Print Option Type P17 (M547-02)	39
Accessory Check	39
Installation Procedure	39
VM Card Type P18 (D3EN)	40
Accessory Check	40
Installation Procedure	40
PostScript3 Unit Type P17 (M547-04, 05, 06)	41
Accessory Check	41
Installation Procedure	41
Camera Direct Print Card Type P17 (M547-03)	42
Accessory Check	42
Installation Procedure	42
Security Setting	43
Security Function Installation	43
Data Overwrite Security	44
HDD Encryption	45
@Remote Settings	49
Operation Guidance for Users	52
3. Preventive Maintenance	53
Preventive Maintenance Tables	53
Yield Parts Settings	54
Yield Parts Replacement Procedure	54
4. Replacement and Adjustment	56
Notes on the Main Power Switch	56
Push Switch	56
Beforehand	58
Special Tools	59
Image Adjustment	60
Printing	60

SMC Storage .....	63
External Covers .....	64
Front Cover .....	64
Interface Cover .....	67
Upper Right Cover .....	68
Middle Right Cover .....	68
Lower Right Cover .....	70
Upper Left Cover.....	71
Middle Left Cover.....	72
Lower Left Cover.....	73
Rear Cover .....	74
Operation Panel.....	76
Laser Unit .....	77
Caution Decal Locations .....	77
Laser Unit .....	77
Development Unit .....	86
Development Unit .....	86
Drum Unit .....	88
Drum Unit.....	88
Charge Roller.....	90
Transfer Unit.....	92
Image Transfer Section.....	92
Paper Transfer Roller Unit .....	97
Fusing Unit .....	99
Fusing Unit.....	99
Paper Exit Unit.....	102
Paper Exit Unit.....	102
Paper Feed Unit .....	107
Paper Conveying Unit .....	107
Paper Feed Roller and Pickup Roller.....	110
Retard Roller.....	115
Bypass Tray Unit .....	122
Bypass Paper Feed Roller .....	122
Drive Unit.....	128
Main Drive Motor Unit .....	128
Conveying Drive Unit .....	134
Paper Feed Drive Unit .....	136
Toner Motor Unit .....	138
Toner Motor (M11).....	142

Lift Motor (M9) .....	146
Duplex Unit .....	150
Duplex unit .....	150
Electrical Components .....	153
Controller Box .....	153
Controller Board (PCB3) .....	155
BiCU (PCB2) .....	158
Main/Engine PCB (PCB1) .....	160
HVP (PCB19) .....	164
HVP 2 (PCB20) .....	165
PSU (PCB9) .....	167
Engine Relay PCB (PCB21) .....	168
NFC Board (PCB4) .....	170
Fans .....	173
Paper Feed Unit (Paper Feed Unit PB1150) .....	174
Retard Roller Unit .....	174
Paper Feed Roller and Pickup Roller .....	175
Main Board .....	177
Drive Unit .....	181
5. System Maintenance .....	189
Service Program Mode .....	189
SP Tables .....	189
Firmware Update .....	190
Overview .....	190
Procedure .....	190
Error Screens During Updating .....	191
RFU Updating the Firmware .....	195
RFU Performable Condition .....	195
Updating JavaVM .....	196
Procedure .....	196
Capturing the Debug Logs .....	199
Overview .....	199
Retrieving the Debug Logs .....	201
NVRAM Data Upload/Download .....	206
Uploading Content of NVRAM to an SD card .....	206
Downloading an SD Card to NVRAM .....	206
SMC List Card Save Function .....	208
Overview .....	208
Procedure .....	208

File Names of the Saved SMC Lists .....	209
Error Messages.....	209
Test Pattern Printing.....	211
Procedure .....	211
6. Troubleshooting .....	212
Self-Diagnostic Mode.....	212
Service Call Codes .....	212
SC Logging .....	213
SC Automatic Reboot .....	213
Service Call 195 .....	216
SC100 (Engine: Others).....	216
Service Call 202-271 .....	217
SC200 (Engine: Image Writing) .....	217
Service Call 302-398 .....	223
SC300 (Engine: Imaging 2: Around the Drum) .....	223
Service Call 441-497 .....	241
SC400 (Engine: Imaging 3: Around the Drum) .....	241
Service Call 501-580 .....	251
SC500 (Engine: Paper Transport 1: Paper Feed, Duplex, Transport).....	251
SC500 (Engine: Paper Transport 2: Fusing, Others) .....	257
Service Call 622-691 .....	265
SC600 (Engine: Communication and Others).....	265
SC600 (Controller).....	271
Service Call 816-899 .....	273
SC800 (Controller).....	273
Service Call 900-998 .....	286
SC900 (Controller).....	286
Jam Detection.....	289
Paper Jam Display.....	289
Jam Codes and Display Codes.....	289
Sensor Layout.....	292
Paper Size Codes .....	293
SC670 (engine startup error) is displayed .....	294
7. Detailed Descriptions .....	295
Product Overview .....	295
Component Layout / Paper Path.....	295
Parts Layout.....	296
Laser Unit .....	303
Development Unit .....	305

Drum Unit .....	307
Transfer Unit.....	309
ITB Unit.....	309
PTR Unit .....	310
Fusing Unit .....	312
Paper Exit Unit.....	314
Duplex Unit .....	315
Paper Feed Unit .....	317
Bypass Tray Unit .....	319

# 1.Product Information

---

## Product Overview

See [Detailed Descriptions](#) for the following information:

- Component Layout/Paper Path
- Parts Layout

## Machine Codes and Peripherals Configuration

### Main Machine

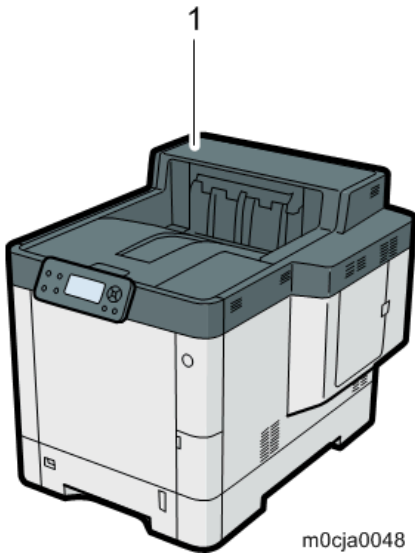

No.	Item	Machine Code
1	P C600	M0CJ-17 (NA) M0CJ-27 (EU) M0CJ-29 (AP)

### Options

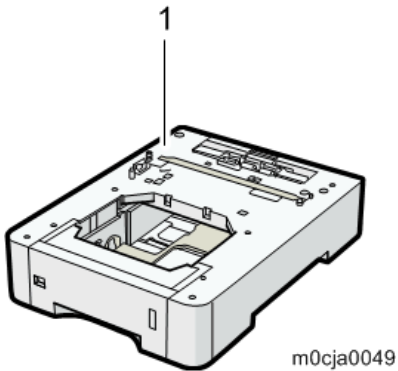

No.	Item	Machine Code
1	Paper Feed Unit PB1150 *1	M544-01
-	Hard Disk Drive Option Type P17	M547-01
-	Enhanced Security HDD Option Type M10	D792-09
-	IEEE 1284 Interface Board Type M19	D3C0-17
-	IEEE 802.11 Interface Unit Type M24	M500-08
	USB Device Server Option Type M19A	D3BC-33 (NA) D3BC-34 (EU/AP)
-	XPS Direct Print Option Type P17	M547-02

No.	Item	Machine Code
-	VM Card Type P18	D3EN-03 (NA) D3EN-04 (EU) D3EN-05 (AP)
-	PostScript3 Unit Type P17	M547-04 (NA) M547-05 (EU) M547-06 (AP)
-	Camera Direct Print Card Type P17	M547-03

\*1 You can attach up to three paper feed units.

 **Note**

The following options are installed by the end user. For instructions on installing these options, please refer to the operating instructions "Operating Instructions".

- Paper Feed Unit PB1150
- Hard Disk Drive Option Type P17
- IEEE 1284 Interface Board Type M19
- IEEE 802.11 Interface Unit Type M24
- USB Device Server Option Type M19A
- XPS Direct Print Option Type P17
- VM Card Type P18
- PostScript3 Unit Type P17
- Camera Direct Print Card Type P17

## 1.Product Information

### **Specifications**

See "Appendices" for the following information:

- General Specifications
- Supported Paper Sizes
- Software Accessories
- Optional Equipment

## 2. Installation

### Installation Requirements

#### Environment

##### Optimum Environmental Conditions

Permissible and recommended temperature and humidity ranges are as follows:

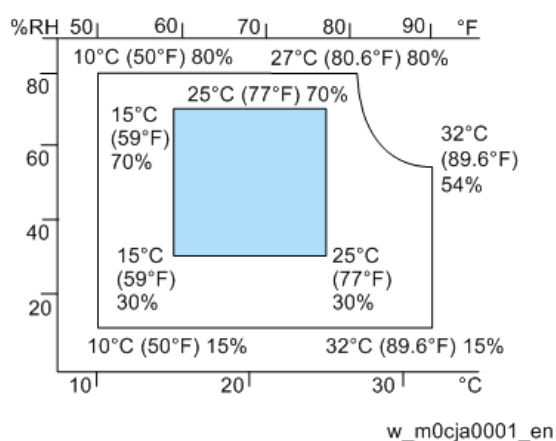

- White area: permissible range
- Blue area: recommended range

##### Service Environmental Conditions

The service environmental conditions are as follows:

- Temperature: 50 to 89.6 °F (10 to 32 °C)  
(But temperature should be 80.6 °F (27 °C) or lower when humidity is 80%.)
- Humidity: 15 to 80%  
(But humidity should be 54% or lower when temperature is 89.6 °F (32 °C).)

Adverse environmental conditions may affect the image quality. It is recommended to use the machine at a temperature around 59 to 77 °F or less (15 to 25 °C), and humidity around 30 to 70%.

Avoid the following locations when selecting a site for the machine.

- Avoid locations near a window or with exposure to direct sunlight.
- Avoid locations with vibrations.
- Avoid locations with drastic temperature fluctuations.
- Avoid locations with direct exposure to hot or cold air.
- Avoid poorly ventilated locations.

During printing, some ozone is released, but the amount does not cause any ill effect to one's health. If, however, the machine is used over a long period of time in a poorly ventilated room or when making an extremely large number of copies, the smell may become unpleasant. To maintain the appropriate environment for copy work, it is suggested that the room be properly ventilated.

## 2. Installation

---

### Machine Level

---

Front to back: Within 5 mm (0.2") of level

Right to left: Within 5 mm (0.2") of level

---

### Minimum Space Requirements

---

Place the machine near the power source, and provide clearance as shown:

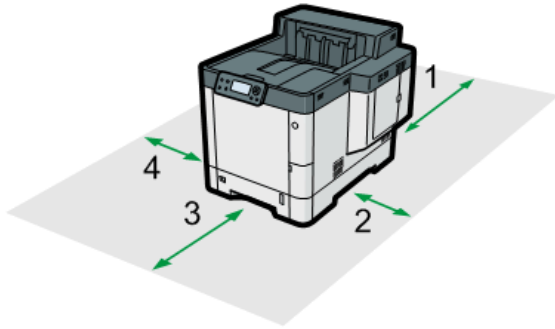

m0cja0002

Main machine only:

1. Rear: Over 350 mm (13.8")
2. Right: Over 200 mm (7.9")
3. Front: Over 450 mm (17.8")
4. Left: Over 200 mm (7.9")

Full system:

1. Rear: Over 300 mm (11.9")
2. Right: Over 200 mm (7.9")
3. Front: Over 500 mm (19.7")
4. Left: Over 300 mm (11.9")

#### Note

- The 450/500 mm clearance for the front is only for pulling out the paper tray. If an operator stands in front of the machine, more space is required.

---

### Machine Dimensions

---

W×D×H: 445 × 570 × 469.5 mm (17.5" × 22.4" × 18.5")

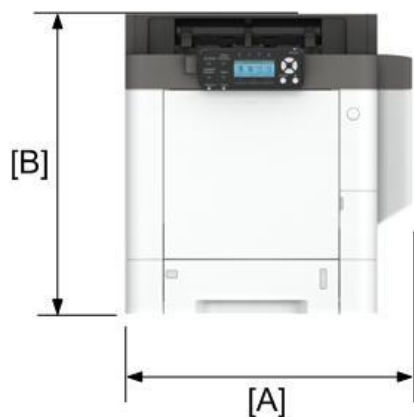

m0cja0003

- [A]: 445 mm (17.5")
- [B]: 469.5 mm (18.5")

---

## Power Requirements

---

### **⚠ CAUTION**

- Make sure that the wall outlet is near the machine and easily accessible.
- Make sure the plug is firmly inserted in the outlet.
- Avoid multi-wiring.
- Be sure to ground the machine.

### **Input voltage**

- NA: 120 to 127 V, 12 A, 60 Hz
- EU/AP: 220 to 240 V, 7 A, 50 Hz/60 Hz

For users in Norway, this product is also designed for an IT power distribution system with phase-to-phase voltage of 230V.

## Main Machine Installation

### Installation Flowchart

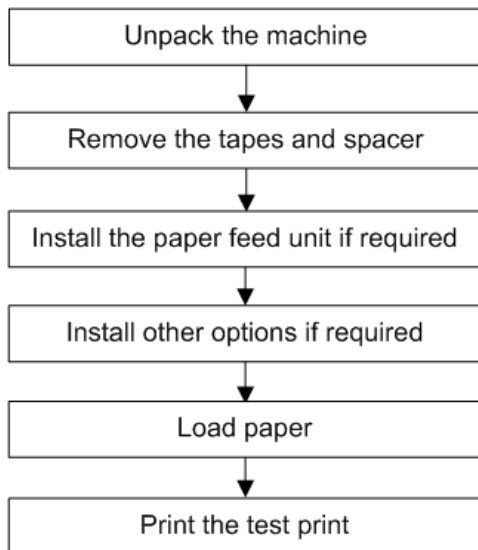

w\_m0cja0004\_en

### Accessory Check

Check the quantity and condition of these accessories.

No.	Description	Q'ty		
		NA	EU	AP
1	Decal: Paper grade	1	-	-
2	Manual: Safety Information	1	3	1
3	Power cord	1	1	1
4	Starter toner	1	1	1
5	CD-ROM: Drivers	1	1	1
6	Sheet: Quick Installation Guide	1	2	1
7	Guarantee sheet	1	-	-
8	Sheet: Control panel	1	1	-
9	Sheet: Security	1	1	1
10	Sheet: User Registration	1	-	-
11	Sheet: Help Desk Card	1	-	-
12	Sheet: EULA (End User License Agreement)	1	1	1
13	Seal: Caution	1	1	1
14	Sheet: TRCU	-	1	-
15	Decal: Inkjet	1	3	1

---

## Installation Procedure

---

This machine is installed by the end user.

For instructions on unpacking and installing the machine, please refer to the operating instructions "Quick Installation Guide".

---

## Settings According to the Service Contract

---

Change the necessary settings depending on the customer's service contract.

### Meter Click Charge

---

There are two ways to set up this function.

- **Meter click charge enabled (SP5-930-001 set to "1 (enabled)"; this is the default setting):** The counter can be displayed and printed by the customer. The service representative can then call the customer and ask for the counter.
- **Meter click charge disabled (SP5-930-001 set to "0 (disabled)"):** The counter cannot be displayed or printed by the customer. To check the counter, the service representative must print the SMC report (SP 5-990).

Item	SP No.	Function	Default
Meter Click Charge	SP5-930-001	Enables or disables Meter Click Charge. When enabled: <ul style="list-style-type: none"> <li>• The counter menu shows immediately after you push the "Menu" key.</li> <li>• You can print the counter from the counter menu.</li> </ul> When disabled: <ul style="list-style-type: none"> <li>• The counter menu does not show.</li> </ul>	1: ON
Meter Click Charge: Maintenance Kit	SP5-931-001	Enables or disables the PM alert for the maintenance kit.  * This setting is unnecessary with this machine since this machine does not have the maintenance kit.	0: No alert
Counter Method	SP5-045-001	Specifies the counter display method. <ul style="list-style-type: none"> <li>• 0: Developments</li> <li>• 1: Pages</li> <li>• 2: Coverage range</li> <li>• 3: Pages and Economy Color (color count up mode)</li> <li>• 4: Pages and Economy Color (B&amp;W count up</li> </ul>	1: Pages

## 2. Installation

Item	SP No.	Function	Default
		mode) • 7: Coverage (YMC)	
Service Tel: Telephone/Facsimile	SP5- 812-001, -002	-001: shows or sets the telephone number of the service representative. -002: shows or sets the fax number of the service station. This number is displayed on the error message screen when an SC occurs.	-

---

### Moving the Machine

---

This section shows you how to manually move the machine from one floor to another floor. See the section "Transporting the Machine" if you have to pack the machine and move it a longer distance.

- Turn OFF the main power and pull out the power plug.
- Close all the covers and trays.
- Remove peripherals physically attached to the main machine: paper feed unit.
- Keep the machine horizontal and move it slowly. Tipping or excessive vibrations may damage the machine.

---

### Transporting the Machine

---

- 1.** Open the upper cover [A].



m0cja0029

- 2.** Release the lock lever [A] by rotating it towards you, and then remove the toner cartridge [B]. Repeat this step for all four toner cartridges.

This prevents toner leakage caused by vibration during transport.

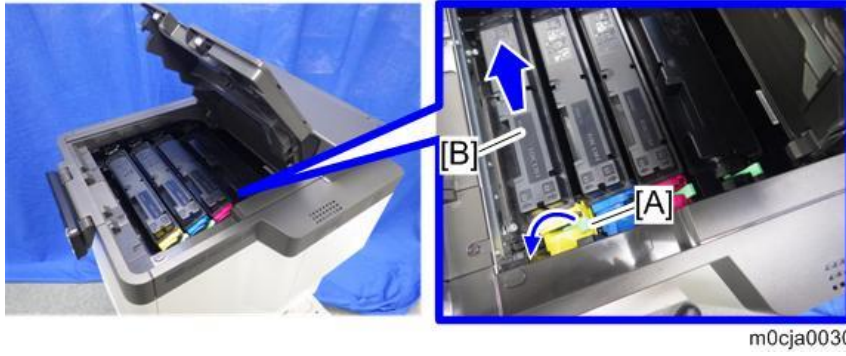

- 3.** Make sure there is no paper left in the paper trays. Then fix down the bottom plates with a sheet of paper and tape.
- 4.** Lift the machine, and then move it horizontally to the new location.

## Paper Feed Unit PB1150 (M544)

### Accessory Check

No.	Description	Q'ty
1	Paper feed unit	1
-	Manual: Installation Guide	1
-	EMC address decal	1

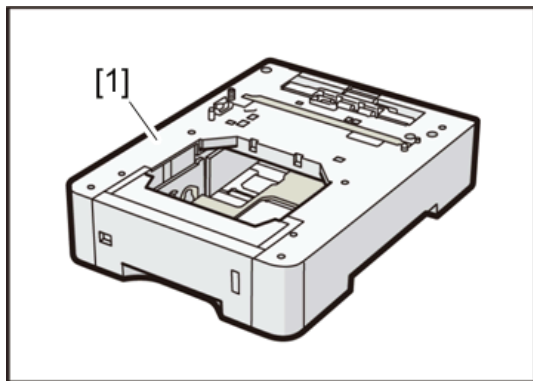

m0cja0031

### Installation Procedure

For instructions on unpacking and installing Paper Feed Unit PB1150, please refer to "Operating Instructions".

## Hard Disk Drive Option Type P17 (M547-01)

### Accessory Check

No.	Description	Q'ty
1	Bracket: HDD: Ass'y	1
2	Power source cable	1
3	Data cable	1
4	Screw:M111	2
-	EMC address sheet	1

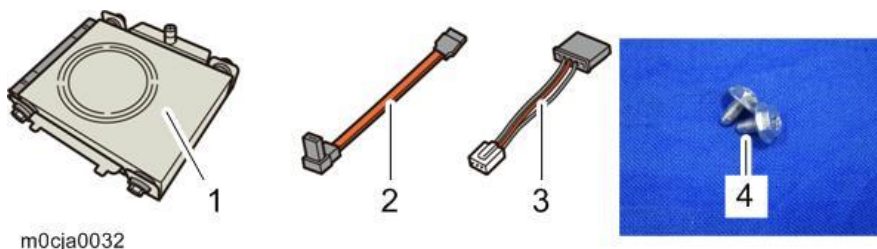

### Installation Procedure

Hard Disk Drive Option Type P17 is installed by the end user. For instructions on installing, please refer to "Operating Instructions".

#### After Installing the HDD

- 1.** Connect the power cord and turn ON the main power.  
The message "Hard Disk is replaced. Format Hard Disk." is displayed.
- 2.** Select [Format]. The message "Formatting Hard Disk...Please wait, also make sure the main power switch is not turned off." is displayed.
- 3.** Wait for the machine to finish formatting the hard disk.
 

**★ Important**

  - Do not touch the power switch while the hard disk format is in progress. Wait for the machine to tell you that the formatting is finished. When the formatting is finished, the message "Hard Disk is formatted. Turn main power switch off then on" is displayed.
- 4.** Turn the main power OFF/ON after the message tells you formatting is finished.

2.Installation

## Enhanced Security HDD Option Type M10 (D792-09)

### Accessory Check

No.	Description	Q'ty
1	Enhanced security HDD	1
-	EMC address sheet	1



d191b0076

**Note**

- The following parts are separately required when installing Enhanced Security HDD Option Type M10 on P C600 in which Hard Disk Drive Option Type P17 is not installed.

No.	Description	Q'ty
1	HDD bracket	1
2	Power source cable	1
3	Data cable	1
4	Stepped screw	4
5	Tapping screw	2

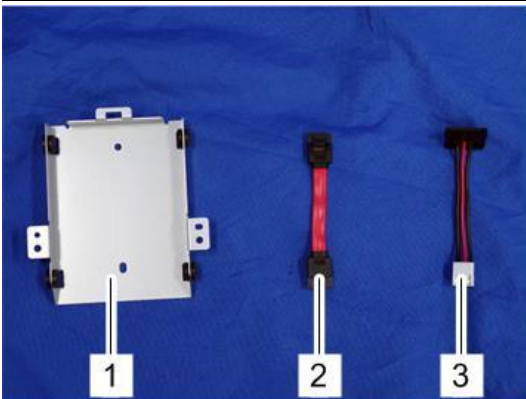

m0cja0033



## Installation Procedure

1. Remove the enhanced security HDD from its protective pack.



d191b0078

2. Connect the power source cable [A] and data cable [B] to the enhanced security HDD [C].

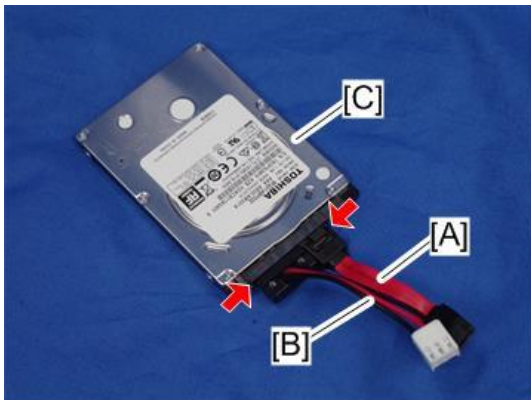

x2

m0cja0250

3. Install the enhanced security HDD [A] on the HDD bracket [B] with the stepped screws.

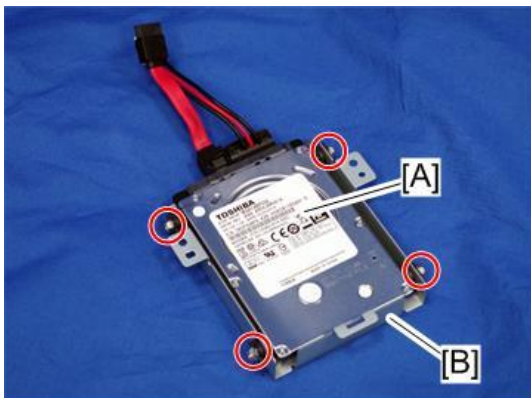

x4

m0cja0246

## 2. Installation

### 4. Remove the HDD cover.

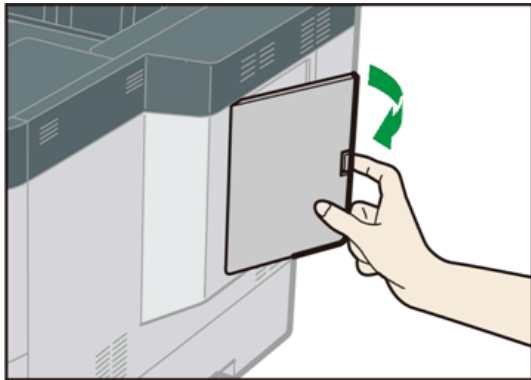

m0cja0027

### 5. Pull up the shield lid [A] and pull it toward you to remove it.



 x2

m0cja0247

### 6. Install the HDD with the bracket [A].

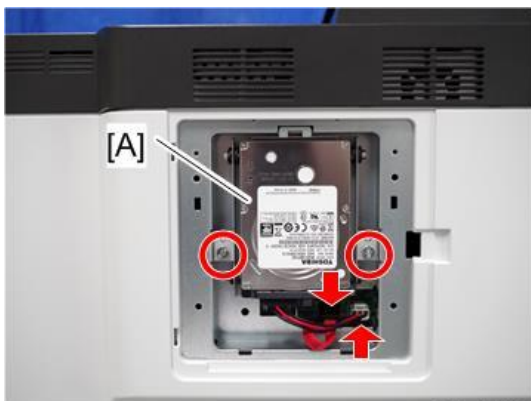

 x2  x2

m0cja0248

**★ Important**

- Connect the connectors as follows.

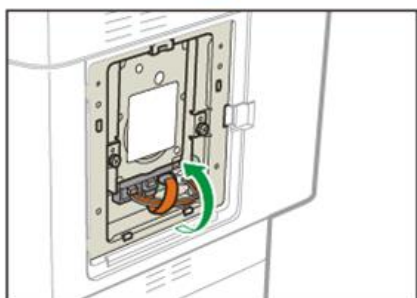
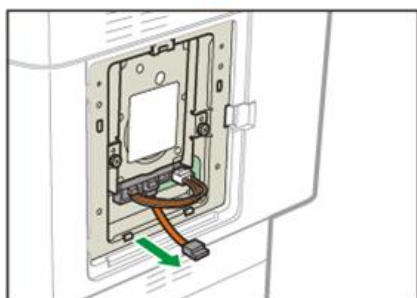
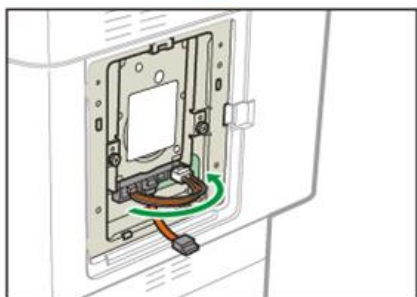
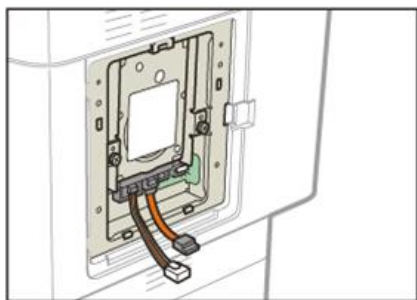

m0cja0256

## 2. Installation

### 7. Attach the shield lid [A].

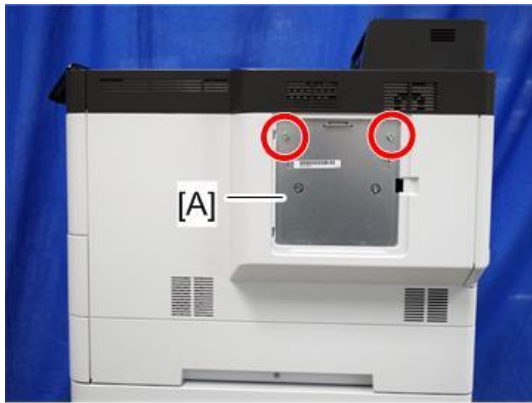

 x2

m0cja0251

### 8. Attach the HDD cover.

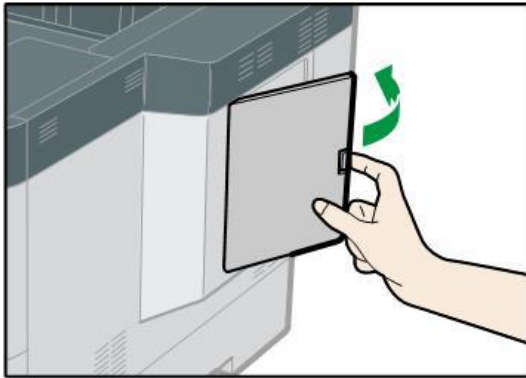

m0cja0249

- Connect the connectors as follows.

#### After Installing the HDD

---

1. Connect the power cord and turn ON the main power.  
The message "Hard Disk is replaced. Format Hard Disk." is displayed.
2. Select [Format]. The message "Formatting Hard Disk...Please wait, also make sure the main power switch is not turned off." is displayed.
3. Wait for the machine to finish formatting the hard disk.  
**★ Important**
  - Do not touch the power switch while the hard disk format is in progress. Wait for the machine to tell you that the formatting is finished. When the formatting is finished, the message "Hard Disk is formatted. Turn main power switch off then on" is displayed.
4. Turn the main power OFF/ON after the message tells you formatting is finished.

## Internal Options

### List of Slots

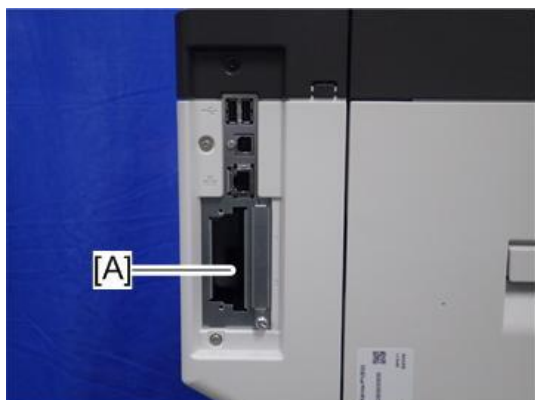

m0cja0034

Slot		Option
[A]	I/F slot	IEEE 1284 Interface Board Type M19
		IEEE 802.11 Interface Unit Type M24
		USB Device Server Option Type M19A

## IEEE 1284 Interface Board Type M19 (D3C0-17)

### Accessory Check

No.	Description	Q'ty
1	IEEE 1284 interface board	1
-	EMC address sheet	1
-	FCC sheet	1
-	RoHS sheet	1
-	RoHS decal	1

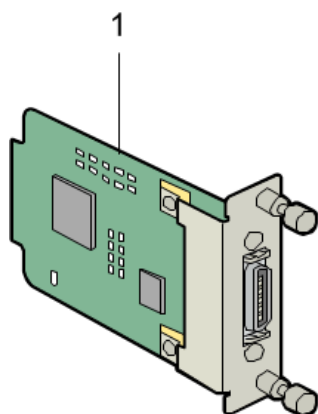

d255a1292

### Installation Procedure

IEEE 1284 Interface Board Type M19 is installed by the end user. For instructions on installing, please refer to "Operating Instructions".

## IEEE 802.11 Interface Unit Type M24 (M500-08)

### Accessory Check

No.	Description	Q'ty
1	IEEE 802.11 interface board	1

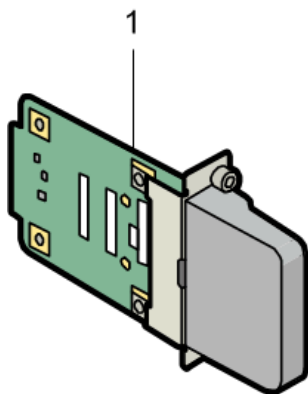

d255a1298

### Installation Procedure

IEEE 802.11 Interface Unit Type M24 is installed by the end user. For instructions on installing, please refer to "Operating Instructions".

## USB Device Server Option Type M19 (D3BC-28, 29)

### Accessory Check

No.	Description	Q'ty
1	USB cable	1
2	Interface board	1
3	Ferrite core	2
4	Cable ties	2

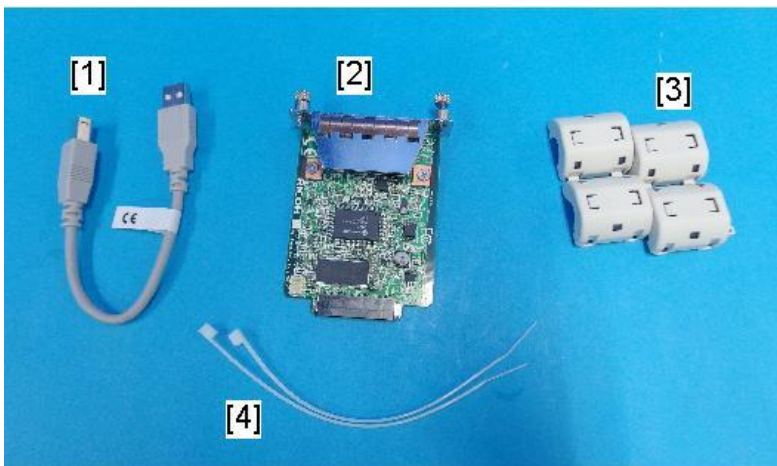

d238m0666

### Interface Board

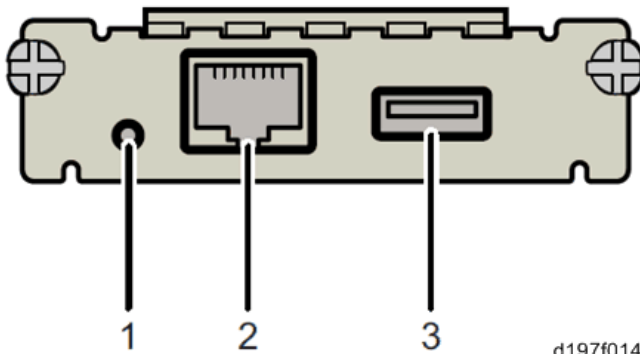

d197f0142

No.	Item	Description
1	Switch	Use to reset to the factory settings.
2	Ethernet port	Use to connect the Ethernet cable.
3	USB port	Use to connect this option to the main machine. Do not use this port with other options.

### Installation Procedure

#### ★ Important

- When you install this option to the main machine for the first time, the interface board must be

connected directly to your PC to set up the IP address and other network settings.

- Turn OFF the main power, and unplug the machine power cord before starting the following procedure.

**1.** Loosen the two screws and remove the slot cover [A] from the rear side of the machine.



 x2

m0cja0005

**2.** Fully insert the interface board [A].

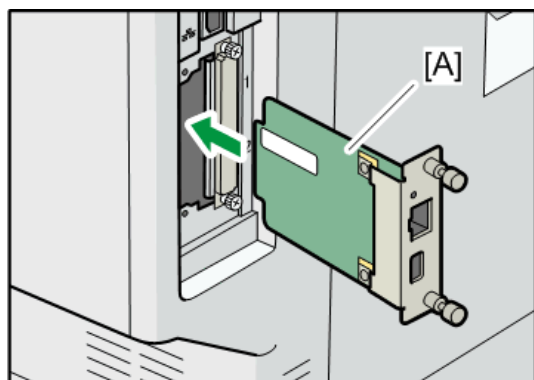

m0cja0006

**3.** Tighten the two screws to secure the interface board.

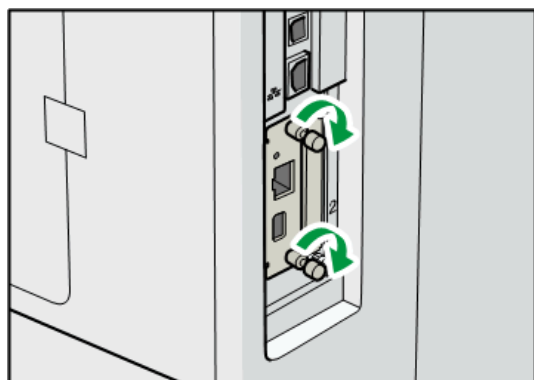

 x2

m0cja0007

## 2. Installation

- Using the supplied USB cable [A], connect the USB device server to the machine.

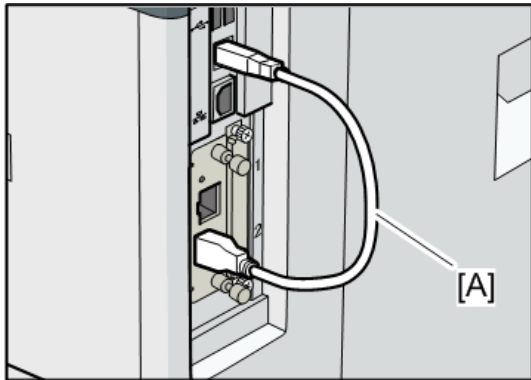

m0cja0008

- Mount the ferrite cores on the Ethernet cable, while looping the cable at 3 cm (approx. 1.2 inch) [A] from the each end of the cable.

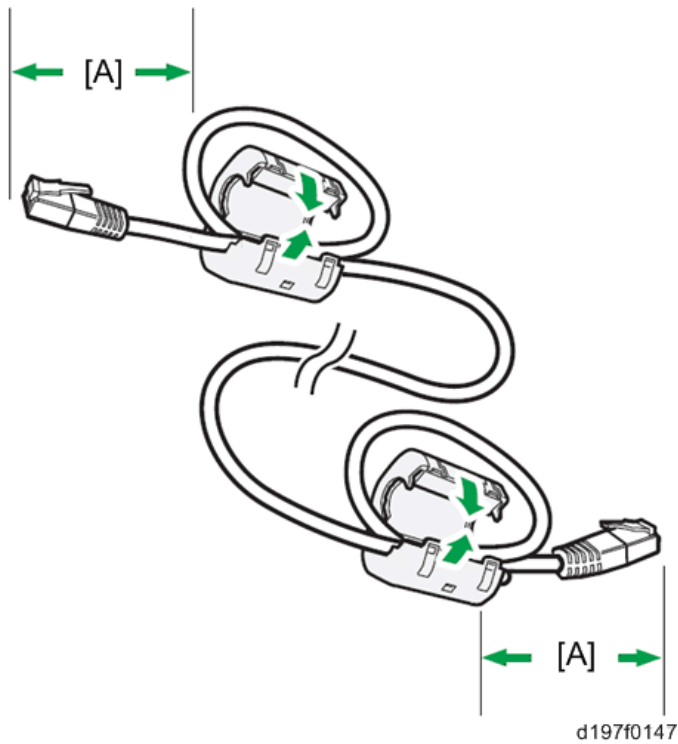

d197f0147

- Only when installing this option in NA, fix each ferrite core with the cable tie [A].

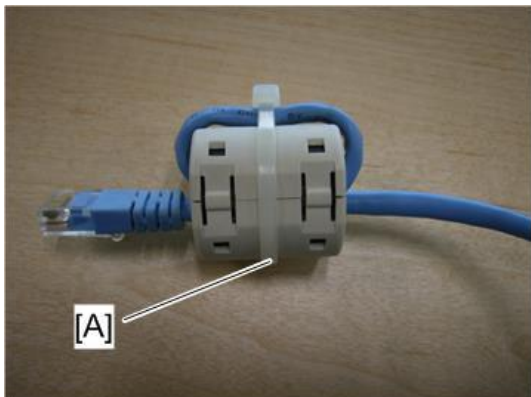

m0aga0078

- 7.** Insert the Ethernet cable [A] into the Ethernet board on this option.

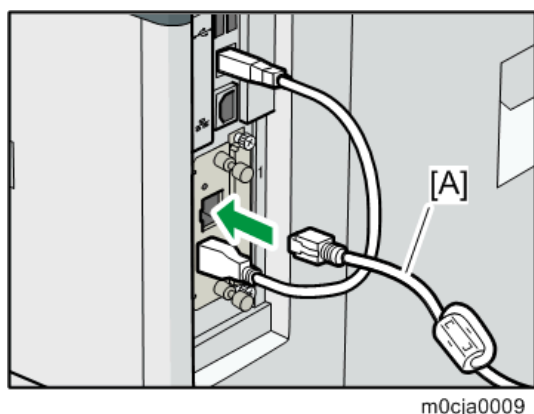

- 8.** Insert the other end of the Ethernet cable to a PC for network setting.  
**9.** Plug the power cord into the wall socket and turn ON the main power.

**Note**

- Do not unplug the USB connector while the machine is recognizing this option. It may take between 30 seconds to 1 minute to finish recognizing it (the LEDs by the connector light up when finished; see below). If unplugged, connect the cable again.

### What Do the LED Indicators Mean?

When this option is properly installed and recognized by the main machine, the LED indicators light up under the following conditions.

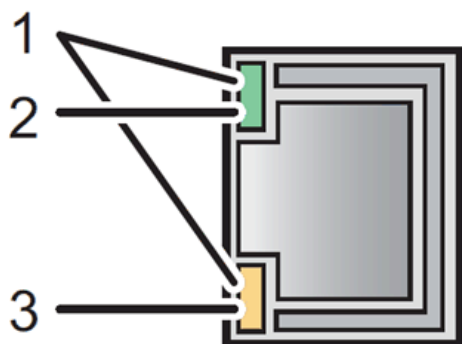

d197f0149

No.	LED Color	Lights Up When:
1	Green and Yellow	1000BASE-T operates.
2	Green	10BASE-T operates.
3	Yellow	100BASE-TX operates.

### Notes for Energy Save Mode Setting

If the machine which has this option enters the energy save mode, you cannot print because there will be a communication error. Follow the instructions below to disable the energy save mode.

- Select [System] -> Press [OK] on the controller panel.
- Select [Engy Sv Md to Dsbl Prt Srv] -> Press [OK].
- Select [Disable Mode] -> Press [OK].

## 2. Installation

### IP Address Setting

---

This section describes how to set an IP address on this option manually. You can set an IP address which is not only on the same network segment but also on a different network segment to share a single machine with devices in multiple networks.

#### ★ Important

- You cannot change the IP address from the operation panel of the main machine. The setting must be done from a web browser on your PC.
- The network setting of this option is initially assigned as follows: IP address: 192.168.100.100 / Subnet mask: 255.255.255.0
- The network setting of your PC must be in the same network segment in order to change the network setting of this option.

- 1.** Make a note of the current network settings of your PC.
- 2.** Change the IP address on your PC to [192.168.100.xxx (\*0 - 255)].
- 3.** Change the subnet mask on your PC to [255.255.255.0].
- 4.** Open a web browser.
- 5.** Type [http://192.168.100.100/] in the address bar.
- 6.** Press the "Enter" key.

#### ↓ Note

- The setting screen for this option appears.

- 7.** Click [Network Setting].

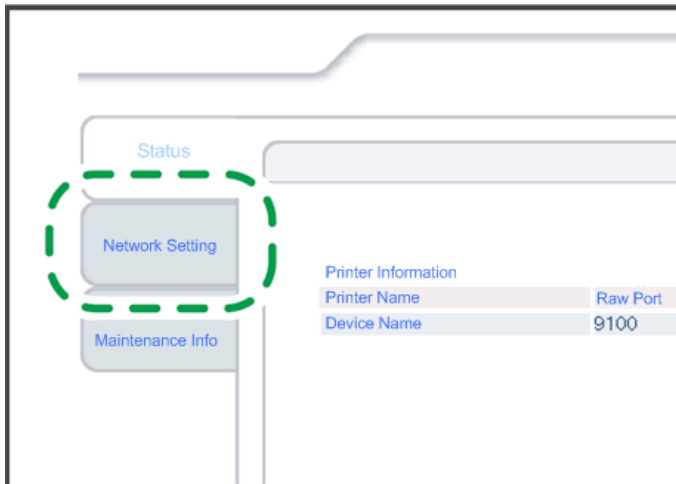

d197f0134

- 8.** Enter "root" in the user name textbox and click [OK].

- 9.** Input [IP Address], [Subnet Mask] and [Default Gateway].

Item	Value
IPv4	ENABLE ▾
DHCPv4	DISABLE ▾
IPv4 address	192.168.100.100
Subnet Mask	255.255.255.0
Default Gateway	0.0.0.0

d197f0135a

- 10.** Set other items if necessary.
- 11.** Click [Submit].
- 12.** Close the web browser.
- 13.** Disconnect the Ethernet cable from the PC.
- 14.** Connect the Ethernet cable to a network device (for example, switching hub).
- 15.** Set the IP address of this option in the printer driver that you are using.

#### Check All Connections

---

- 1.** Plug in the power cord. Turn ON the main power.
- 2.** Print the configuration page.
  1. Select [List/Test Print] -> Press [OK] on the controller panel.
  2. Select [Config. Page] -> Press [OK].

## SD Card Options

### SD Card Slots

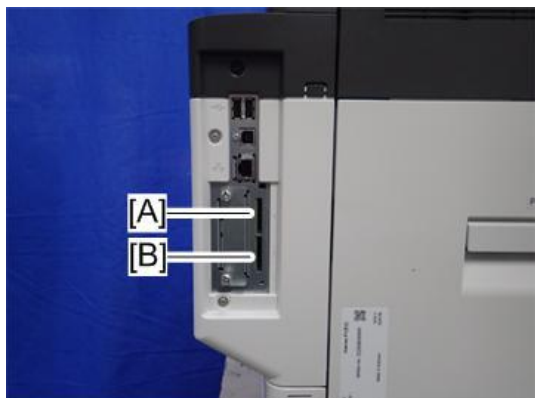

m0cja0035

Slots		Description
[A]	SD Card Slot 1 (service slot)	<ul style="list-style-type: none"> <li>For service use (for example, updating the firmware)</li> <li>For setting VM Card Type P18</li> </ul>
[B]	SD Card Slot 2 (option slot)	Use for the following SD card options. <ul style="list-style-type: none"> <li>XPS Direct Print Option Type P17</li> <li>PostScript3 Unit Type P17</li> <li>Camera Direct Print Card Type P17</li> </ul>

**Note**

- VM Card Type P18 must be set in Slot 1.
- Other SD cards can be set in either Slot 1 or Slot 2. However, Slot 1 is the service slot, so it is recommended that Slot 2 be used to install the SD card options.

## SD Card Appli Move

---

### Overview

---

The service program "SD Card Appli Move" (SP5-873) lets you copy application programs from one SD card to another SD card.

You can move application programs from Slot 1 to Slot 2 with the following procedure.

Be very careful when you do the SD Card Appli Move procedure:

- The necessary data for authentication is transferred with the application program from an SD card to another SD card. Authentication fails if you try to use the SD card after you copy the application program from one card to another card.
- Do not use the SD card if it has been used before for other purposes. Normal operation is not guaranteed when such an SD card is used.
- Keep the SD card in a safe place after you copy the application program from one card to another card. This is for the following reasons:
  - 1) The SD card can be the only proof that the user is licensed to use the application program.
  - 2) You may need to check the SD card and its data to solve a problem in the future.

### Storing the SD card

The SD card from which you moved an application can be stored in the top tray.

1. Lift the handle [A] and open the top tray [B].

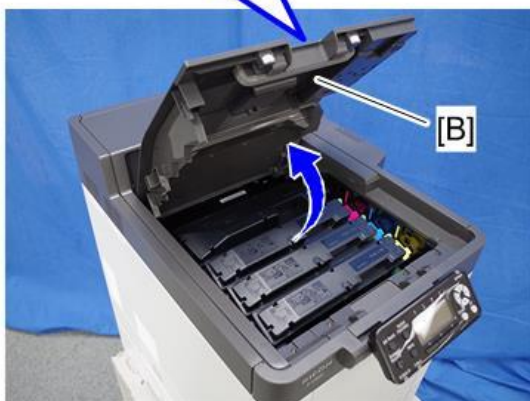

m0cja0050

## 2. Installation

2. Release two hooks [A] with a flat-blade screwdriver and remove the cover [B].

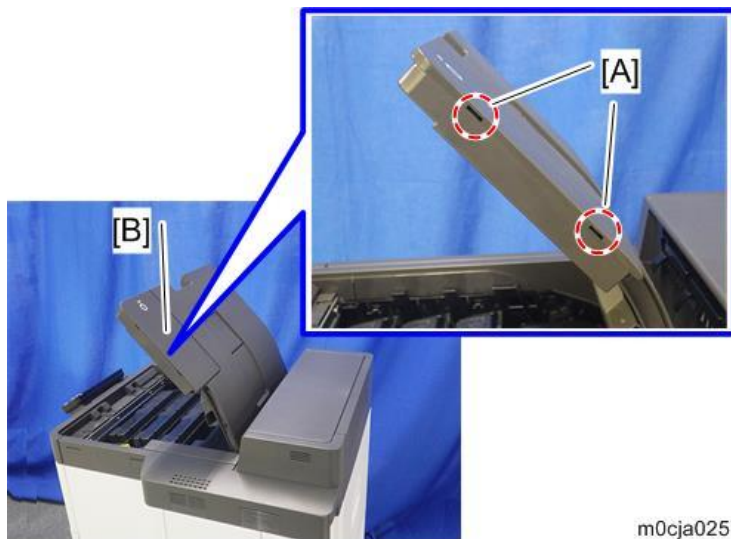

m0cja0257

▼ x2

3. Close the top tray [A].

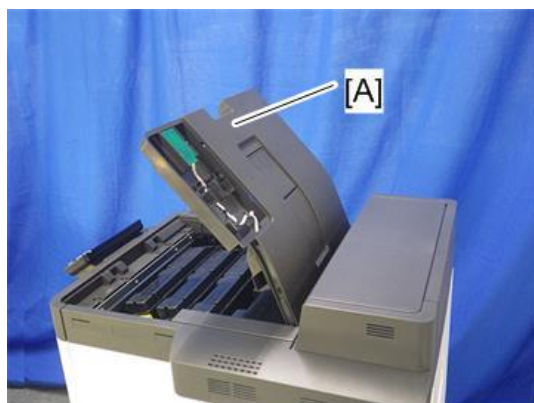

m0cja0258

4. Put the SD cards inside.

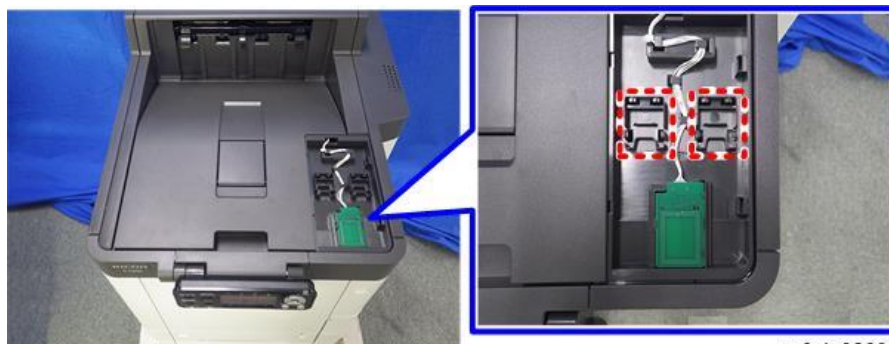

m0cja0268

Up to two SD cards can be stored.

---

## SD Card Appli Move

---

1. Choose an SD card with enough space.
2. Enter SP5-873 "SD Card Appli Move". This SP copies the application programs from the original SD card in SD Card Slot 1 to the SD card in SD Card Slot 2. Move the application from the SD card

in Slot 1 to the card in Slot 2.

- 3.** Exit the SP mode.

---

## Move Exec

---

The menu "Move Exec" (SP5-873-001) lets you copy application programs from the original SD card to another SD card.

### ★ Important

- Do not turn ON the write protect switch of any application SD card. If the write protect switch is ON, a download error (e.g. Error Code 44) occurs during a firmware upgrade or application merge.

- 1.** Turn OFF the main power.
- 2.** Make sure that an SD card is in SD Card Slot 2. The application program is copied to this SD card.
- 3.** Insert the SD card (having stored the application program) in SD Card Slot 1. The application program is copied from this SD card.
- 4.** Turn ON the main power.
- 5.** Enter the SP mode.
- 6.** Select SP5-873-001 "Move Exec".
- 7.** Follow the messages shown on the operation panel.
- 8.** Turn OFF the main power.
- 9.** Remove the SD card from SD Card Slot 1.
- 10.** Turn ON the main power.
- 11.** Check that the application programs run normally.

---

## Undo Exec

---

The menu "Undo Exec" (SP5-873-002) lets you copy back application programs from an SD card to the original SD card. You can use this program when, for example, you have mistakenly copied some programs by using Move Exec (SP5-873-001).

### ★ Important

- Do not turn ON the write protect switch of any application SD card. If the write protect switch is ON, a download error (e.g. Error Code 44) occurs during a firmware upgrade or application merge.

- 1.** Turn OFF the main power.
- 2.** Insert the original SD card in SD Card Slot 1. The application program is copied back into this card.
- 3.** Insert the SD card (having stored the application program) in SD Card Slot 2. The application program is copied back from this SD card.
- 4.** Turn ON the main power.
- 5.** Enter the SP mode.
- 6.** Select SP5-873-002 "Undo Exec".

## 2. Installation

**7.** Follow the messages shown on the operation panel.

**8.** Turn OFF the main power.

**9.** Remove the SD card from SD card slot 1.

 **Note**

- This step assumes that the application programs in the SD card are used by the machine.

**10.** Turn ON the main power.

**11.** Check that the application programs run normally.

## XPS Direct Print Option Type P17 (M547-02)

### Accessory Check

No.	Description	Q'ty
1	XPS Direct Print SD card	1

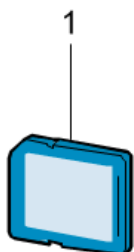

d255a1297

### Installation Procedure

XPS Direct Print Option Type P17 is installed by the end user. For instructions on installing, please refer to "Operating Instructions".

## VM Card Type P18 (D3EN)

---

### Accessory Check

---

No.	Description	Q'ty
1	VM SD card	1
-	Caution sheet (EU only)	1

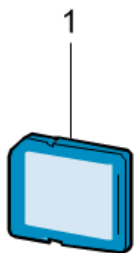

d255a1297

---

### Installation Procedure

---

VM Card Type P18 is installed by the end user. For instructions on installing, please refer to "Operating Instructions".

## PostScript3 Unit Type P17 (M547-04, 05, 06)

### Accessory Check

No.	Description	Q'ty
1	SD Card (PostScript3 Unit)	1
-	Decal	1

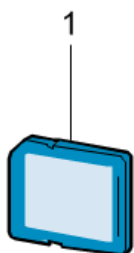

d255a1297

### Installation Procedure

PostScript3 Unit Type P17 is installed by the end user. For instructions on installing, please refer to "Operating Instructions".

## Camera Direct Print Card Type P17 (M547-03)

---

### Accessory Check

---

No.	Description	Q'ty
1	Camera Direct Print SD card	1

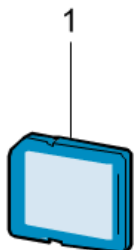

d255a1297

---

### Installation Procedure

---

Camera Direct Print Card Type P17 is installed by the end user. For instructions on installing, please refer to "Operating Instructions".

## Security Setting

### Security Function Installation

The machine contains the Security functions (Data Overwrite Security and HDD Encryption unit) in the controller board (PCB3).

If you are installing a new machine, it is recommended that you activate Data Overwrite Security and HDD Encryption by selecting the following on the operation panel.

- [Security Options] -> [Machine Data Encryption] -> [Encrypt] -> [Carry Over All Data]

#### ↓ Note

- This method is recommended because there is no user data on the HDD yet (Address Book data, image data, etc.).

If the customer wishes to activate the Data Overwrite Security and HDD Encryption unit on a machine that is already running, it is recommended that you activate the unit by selecting the following on the operation panel.

- [Security Options] -> [Machine Data Encryption] -> [Encrypt] -> [Carry Over All Data]

#### ★ Important

- Selecting the setting above will preserve the data that has already been saved to the HDD. (If "Format All Data" is selected, all user data saved to the HDD up to that point will be erased).

Immediately after encryption is enabled, the encryption setting process will take several minutes to complete before you can begin using the machine.

#### ↓ Note

- If encryption is enabled after data has been stored on the HDD, or if the encryption key is changed, this process can take up to three and a half hours or more.

The machine cannot be operated while data is being encrypted.

Once the encryption process begins, it cannot be stopped.

Make sure that the machine's main power is not turned OFF while the encryption process is in progress.

If the machine's main power is turned OFF while the encryption process is in progress, the HDD will be damaged and all data on it will be unusable.

Print the encryption key and keep the encryption key (paper sheet) in a safe place. If the encryption key is lost when you need it, the controller board (PCB3), HDD and NVRAM must all be replaced at the same time.

#### ↓ Note

- "NVRAM" mentioned here means the NVRAM on the controller board (PCB3). It has no relation to the "NVRAM" or EEPROM on the BiCU (PCB2).

Please use the following procedure when the Data Overwrite Security and HDD Encryption are reinstalled.

## 2. Installation

---

### Data Overwrite Security

---

#### Before You Begin the Procedure

---

**1.** Make sure that the following settings (1) to (3) are not at their factory default values.

- (1) Supervisor login password
- (2) Administrator login name
- (3) Administrator login password

If any of these settings are at their factory default values, tell the customer that these settings must be changed before you do the installation procedure.

**2.** Make sure that "Administrator Authentication Management" is on.

- 1. Log in as the administrator from Web Image Monitor.
- 2. [Device Management] -> [Configuration] -> [Device Settings] -> [Administrator Authentication Management]
- 3. From [User Administrator Authentication], [Machine Administrator Authentication], [Network Administrator Authentication], and [File Administrator Authentication], set the administrator authentication setting to [On].

If this setting is off, tell the customer that this setting must be on before you do the installation procedure.

#### Using Auto Erase Memory

---

The Auto Erase Memory function can be enabled by the following procedure.

- 1.** Log in as the machine administrator from the control panel.
- 2.** Select [Security Options] -> Press [OK]
- 3.** Select [Auto Erase Memory Setting] -> Press [OK]
- 4.** Select [On] -> Select [HDD Erase]
- 5.** Select the method of erasing the data from [NSA], [DoD], or [Random Numbers]. -> Press [OK]  
If you select [Random Numbers], enter the number of times that you want to overwrite. Then press [OK].
- 6.** Press [OK].
- 7.** Press [Menu].
- 8.** Log out.

#### Checking the Auto Erase Memory Status

---

If Auto Erase Memory is enabled, you can use the "Memory Erase Status" screen to find out whether there is any data to be erased in the memory.

- 1.** Press the [Menu] key -> Select [Memory Erase Status] -> Press [OK]

The Memory Erase status appears.

---

## HDD Encryption

---

Before You Begin the Procedure:

---

**1.** Make sure that the following settings (1) to (3) are not at their factory default values.

- (1) Supervisor login password
- (2) Administrator login name
- (3) Administrator login password

If any of these settings are at their factory default values, tell the customer that these settings must be changed before you do the installation procedure.

**2.** Make sure that "Administrator Authentication Management" is on.

1. Log in as the administrator from Web Image Monitor.
2. [Device Management] -> [Configuration] -> [Device Settings] -> [Administrator Authentication Management]
3. From [User Administrator Authentication], [Machine Administrator Authentication], [Network Administrator Authentication], and [File Administrator Authentication], set the administrator authentication setting to [On].

If this setting is off, tell the customer that this setting must be on before you do the installation procedure.

### Enable Encryption Setting

---

Machine Data Encryption Settings can be enabled by the following procedure.

**★ Important**

- When setting up encryption, specify whether to start encryption after deleting data (initialize) or encrypt and retain existing data. If data is retained, it may take some time to encrypt it.
- When the Machine Data Encryption Settings is enabled;
  - If the HDD is replaced, HDD data will be deleted. After installing the new HDD, the data in the new HDD will be automatically encrypted.
  - If the NVRAMs on the controller board (PCB3) are replaced, Machine Data Encryption Settings will be automatically enabled after installing the new NVRAMs.
  - If the controller board (PCB3) is replaced, the restore key will be required after installing the new controller board (PCB3).  
If you have the restore key, you will be able to continue using the HDD data.
  - If the restore key has been lost, the HDD will be formatted and you need to reset NVRAM data to the default settings after the forced start-up. (HDD data will be deleted) Refer to "How to do a forced start up with no encryption key" in "Encryption Key Restoration" ([Encryption Key Restoration](#)).
  - If the controller board (PCB3) and the NVRAMs are replaced together, HDD data will be deleted since all the encryption information is deleted.

**1.** Turn ON the main power.

## 2. Installation

- 2.** Log in as the machine administrator from the control panel.
- 3.** Select [Security Options] -> Press [OK]
- 4.** Select [Machine Data Encryption] -> Press [OK]
- 5.** Make sure [Encrypt] is displayed on the control panel -> Press [OK]
- 6.** Select the data to be carried over to the hard disk and not be reset -> Press [OK]
  - To carry all of the data over to the hard disk, select [Carry Over All Data].
  - To carry over only the printer settings data, select [CarryOver FileSys DataOnly].
  - To reset all of the data, select [Format All Data].
- 7.** Select [PrtOnPpr] -> [Print] -> [Continue]
- 8.** Select [OK].
- 9.** Press [Menu].
- 10.** Log out.
- 11.** Turn OFF the main power, and then turn the main power back ON.

The machine will start to convert the data on the memory after you turn ON the main power. Wait until the message "Memory conversion complete. Turn the power switch off." appears, and then turn OFF the main power again.

### Backing Up the Encryption Key

---

You can back up the encryption key by printing it.

#### ★ Important

- The encryption key is required for data recovery if the printer malfunctions. Be sure to store the encryption key safely for retrieving backup data.

- 1.** Log in as the machine administrator from the control panel.
- 2.** Select [Security Options] -> Press [OK]
- 3.** Select [Machine Data Encryption] -> Press [OK]
- 4.** Select [Back Up Encryption Key] -> Press [OK]
- 5.** Select [PrtOnPpr] -> [Print]
- 6.** Press [Menu].
- 7.** Log out.

### Encryption Key Restoration

---

#### How to restore the old encryption key to the machine

The following message appears after the controller board (PCB3) is replaced. In such a case, it is necessary to restore the encryption key to the new controller board (PCB3).

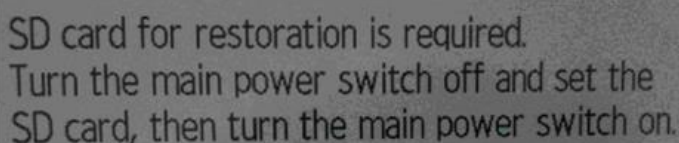

SD card for restoration is required.  
Turn the main power switch off and set the  
SD card, then turn the main power switch on.

d1420101

To do this, follow the procedure below.

- 1.** Prepare an SD card that has been initialized in FAT16 format.
- 2.** Using a PC, create a folder in the SD card and name it "restore\_key".
- 3.** Create a folder in the "restore\_key" folder and name it the same as machine's serial number, "xxxxxxxxxxx" (11 digits).
- 4.** Create a text file called "key\_xxxxxxxxx.txt" and save it in the "xxxxxxxxxxx" folder. Write the encryption key in the text file.

```
/restore_key/xxxxxxxxxxx/key_xxxxxxxxx.txt
```

**Note**

- Ask the administrator to enter the encryption key. The key has already been printed out by the user and may have been saved in the "key\_xxxxxxxxx.txt" file. (The function of back-up the encryption key to the SD card directly is provided 11A products or later.)

- 5.** Turn ON the main power.
- 6.** Confirm that a message is displayed on the LCD telling to insert the SD card that contains the encryption key.
- 7.** Turn OFF the main power.
- 8.** Insert the SD card that contains the encryption key into SD Card Slot 1 (the upper slot).
- 9.** Turn ON the main power.

**Note**

- The machine will automatically restore the encryption key to the flash memory on the controller board (PCB3).

- 10.** Turn OFF the main power when the machine has returned to normal status.
- 11.** Remove the SD card from SD Card Slot 1.

### How to do a forced start up with no encryption key

If the encryption key back-up has been lost, follow the procedure below to do a forced start-up.

**Important**

- The HDD will be formatted after the forced start-up.
- Encrypted data will be deleted.
- User settings will be cleared.

- 1.** Prepare an SD card.
- 2.** Create a directory named "restore\_key" inside the root directory of the SD card. Then, save the "nvram\_key.txt" file using the following name:

```
/restore_key/nvram_key.txt
```

- 3.** Create a text file and write "nvclear".

**Important**

- Write this string at the head of the file.
- Use all lower-case letters.
- Do not use quotation marks or blank spaces.
- It is judged that a forced start has been selected when the content of "nvclear" is executed

## 2. Installation

and the machine shifts to the alternate system (forced start).

- 4.** Confirm that a message is displayed on the LCD telling to insert the SD card that contains the encryption key.
- 5.** Turn OFF the main power.
- 6.** Insert the SD card that contains the encryption key into SD Card Slot 1 (the upper slot).
- 7.** Turn ON the main power, the machine automatically clear the HDD encryption.
- 8.** Turn OFF the main power when the machine has returned to normal status.
- 9.** Remove the SD card from SD Card Slot 1.
- 10.** Turn ON the main power.
- 11.** Execute SP5-801-xx (Exclude SP5-801-001: All Clear and SP5-801-002: Engine (BiCU)) to resets NVRAM data to the default settings.
- 12.** Execute SP5-846-046 to clear the address book information.
- 13.** Set necessary user settings from the [Menu] key.

## @Remote Settings

### Note

- Prepare and check the following check points before you visit the customer site. For details, ask the @Remote key person.

### Check points before making @Remote settings

1. The setting of SP5-816-201 in the mainframe must be "0".
2. Print the SMC with SP5-990-002 and then check if a device ID2 (SP5-811-003) must be correctly programmed.
  - 6 spaces must be put between the 3-digit prefix and the following 8-digit number (e.g. xxx \_\_\_\_\_xxxxxxx).
  - ID2 (SP5-811-003) and the serial number (SP5-811-001) must be the same (e.g. ID2: A01 \_\_\_\_\_23456789 = serial No. A0123456789)
3. The following settings must be correctly programmed.
  - Proxy server IP address (SP5-816-063)
  - Proxy server Port number (SP5-816-064)
  - Proxy User ID (SP5-816-065)
  - Proxy Password (SP5-816-066)
4. Get a request number.

### Execute the @Remote Settings

1. Enter the SP mode.
2. Input the request number which you have obtained from @Remote Center GUI with SP5-816-202.
3. Confirm the request number, and then press [EXECUTE] with SP5-816-203.
4. Check the confirmation result with SP5-816-204.

Value	Meaning	Solution/ Workaround
0	Succeeded	-
3	Communication error (proxy enabled)	Check the network condition.
4	Communication error (proxy disabled)	Check the network condition.
5	Proxy error (authentication error)	Check Proxy user name and password.
6	Communication error	Check the network condition.
8	Other error	See "SP5-816-208 Error Codes" below.
9	Request number confirmation executing	Processing. Please wait.
11	Already registered	-
12	Parameter error	-
20	Dial-up authentication error	* These errors occur only in the modems that support @Remote.
21	Answer tone detection error	

## 2. Installation

Value	Meaning	Solution/ Workaround
22	Carrier detection error	
23	Invalid setting value (modem)	
24	Low power supply current	
25	unplugged modem	
26	Busy line	

**5.** Make sure that the screen displays the location information with SP5-816-205 only when it has been input at the Center GUI.

**6.** Press [EXECUTE] to execute the registration with SP5-816-206.

**7.** Check the registration result with SP5-816-207.

Value	Meaning	Solution/ Workaround
0	Succeeded	-
2	Already registered	Check the registration status.
3	Communication error (proxy enabled)	Check the network condition.
4	Communication error (proxy disabled)	Check the network condition.
5	Proxy error (Authentication error)	Check Proxy user name and password.
8	Other error	See "SP5-816-208 Error Codes" below.
9	Request number confirmation executing	Processing. Please wait.
10	Not registered	
11	Already registered	-
12	Parameter error	-
20	Dial-up authentication error	* These errors occur only in the modems that support @Remote.
21	Answer tone detection error	
22	Carrier detection error	
23	Invalid setting value (modem)	
24	Low power supply current	
25	unplugged modem	
26	Busy line	

**8.** Exit the SP mode.

### SP5-816-208 Error Codes

These are caused by operation errors, or incorrect settings.

Code	Meaning	Solution/ Workaround
- 12002	Inquiry, registration attempted without acquiring Request No.	Obtain a request number before attempting the Inquiry or registration.
-	Attempted registration without execution of a	Perform confirmation before

Code	Meaning	Solution/ Workaround
12003	confirmation and no previous registration.	attempting the registration.
- 12004	Attempted setting with illegal entries for certification and ID2.	Check ID2 of the mainframe.
- 12005	@Remote communication is prohibited. The device has an Embedded RC gate-related problem.	Make sure that "Remote Service" in User Tools is set to "Do not prohibit".
- 12006	A confirmation request was made after the confirmation had been already completed.	Execute registration.
- 12007	The request number used at registration was different from the one used at confirmation.	Check Request No.
- 12008	Update certification failed because mainframe was in use.	Check the mainframe condition. If the mainframe is in use, try again later.
- 12009	The ID2 in the NVRAM does not match the ID2 in the individual certification.	Check ID2 of the mainframe.
- 12010	The certification area is not initialized.	Initialize the certification area.

## Errors Caused by Response from GW URL

Code	Meaning	Solution/ Workaround
-2385	Other error	-
-2387	Not supported at the Service Center	-
-2389	Database out of service	-
-2390	Program out of service	-
-2391	Two registrations for the same mainframe	Check the registration condition of the mainframe.
-2392	Parameter error	-
-2393	External RCG not managed	-
-2394	Mainframe not managed	-
-2395	Box ID for external RCG is illegal.	-
-2396	Mainframe ID for external RCG is illegal.	-
-2397	Incorrect ID2 format	Check the ID2 of the mainframe.
-2398	Incorrect request number format	Check the request number.

## Operation Guidance for Users

Function/Operation	Instruction to provide
<p>Basic machine functions, operations</p>	<ul style="list-style-type: none"> <li>• How to load and replace the toner cartridge and the waste toner bottle                             <div style="border: 1px solid blue; border-radius: 10px; padding: 2px; margin: 5px 0;"> <span style="color: blue;">↓</span> <b>Note</b> </div> <ul style="list-style-type: none"> <li>• This machine has the waste toner bottle (WTB), which is shipped with each toner bottle, and the user needs to replace the waste toner bottle if "Waste Toner full" appears on the display.</li> <li>• Instruct the user to keep an unused WTB which is shipped with the toner bottle even after replacing the toner bottle to prevent a shortage of WTB.</li> <li>• The waste toner bottle is not registered individually as a supply item.</li> </ul> </li> <li>• How to load paper</li> <li>• How to turn ON/OFF the main power</li> <li>• How to clear paper jams</li> <li>• How to program, modify, and delete Address Book entries</li> <li>• Overview of machine options/peripherals</li> <li>• How to take the proper action for SC errors (clearing the error, contacting service and support, etc.), how to interpret @Remote notifications</li> <li>• Important notes to keep in mind whenever moving the machine</li> <li>• Product limitations</li> <li>• How to close the rear cover completely by pushing "Push" panel after closing the rear cover.                             <div style="border: 1px solid blue; border-radius: 10px; padding: 2px; margin: 5px 0;"> <span style="color: blue;">↓</span> <b>Note</b> </div> <p>Alert message "Cover Open. Please close the indicated cover." occurs and/or Jam occurs when the rear cover is NOT closed completely.</p> </li> </ul>
<p>Printer</p>	<ul style="list-style-type: none"> <li>• How to install printer drivers (using the recommended method)</li> <li>• How to connect to a PC (performing the port settings)</li> <li>• How to print out a test page</li> <li>• Overview of various settings inside each tab in the printer driver (e.g. duplex printing)</li> </ul>

## 3.Preventive Maintenance

---

### Preventive Maintenance Tables

See "Appendices" for the following information:

- Preventive Maintenance Tables

## Yield Parts Settings

### Yield Parts Replacement Procedure

The parts mentioned in the table have a target yield. However, the total print volume made by the machine will not reach the target yield within the machine's targeted lifetime if the machine is used under the target usage conditions (APV, color ratio, P/J, and P/O). So, these parts are categorized not as PM parts but as yield parts (EM parts).

1. Enter the SP mode.
2. Output the SMC logging data with SP5-990-004.
3. Set the SP corresponding to the part to be replaced to "1".

Item	SP
Drum unit: K	SP7-622-002
Developer unit: K	SP7-622-003
Drum unit: C	SP7-622-025
Developer unit: C	SP7-622-026
Drum unit: M	SP7-622-048
Developer unit: M	SP7-622-049
Drum unit: Y	SP7-622-071
Developer unit: Y	SP7-622-072
Transfer unit	SP7-622-093
PTR unit	SP7-622-109
Fusing unit	SP7-622-115
Paper feed roller	SP7-622-146
Pickup roller	SP7-622-147
Separation roller	SP7-622-148

**★ Important**

Make sure you set the SP to "1" before you replace the part. If you set it to "1" after replacing the part, the counter for the previous unit will not be stored.

4. Exit the SP mode.
5. Turn OFF the main power.
6. Replace the yield parts and turn ON the main power.  
The machine will reset the PM counter.

### After installing the new yield parts

1. Turn ON the main power.
2. Output the SMC logging data with SP5-990-004 and check the counter value.
3. Check the corresponding SP to make sure that the PM counter is "0".

### 3.Preventive Maintenance

Item	SP
Drum unit: K	SP7-621-002
Developer unit: K	SP7-621-003
Drum unit: C	SP7-621-025
Developer unit: C	SP7-621-026
Drum unit: M	SP7-621-048
Developer unit: M	SP7-621-049
Drum unit: Y	SP7-621-071
Developer unit: Y	SP7-621-072
Transfer unit	SP7-621-093
PTR unit	SP7-621-109
Fusing unit	SP7-621-115
Paper feed roller	SP7-621-146
Pickup roller	SP7-621-147
Separation roller	SP7-621-148

#### Operation check

---

Check if the sample image has been printed normally.

## 4. Replacement and Adjustment

---

### Notes on the Main Power Switch

---

#### Push Switch

---

The main power button of this machine has been changed to a push-button switch (push button) from the conventional rocker switch. The push switch has characteristics and specifications different from the rocker switch. Care must be taken when replacing and adjusting parts.

#### Characteristics of the Push Switch (DC Switch)

---

##### **Power is supplied to the machine even when the main power is turned OFF.**

The push switch in this machine uses DC (direct current). Therefore, if the AC power cord is connected to an electrical outlet, power is supplied to the controller board (PCB3), the operation unit, and other modules even when the main power is turned OFF. When replacing the controller board (PCB3) and the operation unit in this state, not only these boards, it will damage other electrical components. So, when performing maintenance work such as replacing parts, in addition to turning off the main power with the push switch, always unplug the AC power cord.

##### **When you disconnect the power cord from the AC wall outlet, inside the machine there is still residual charge.**

When you disconnect the power cord from the AC wall outlet, inside the machine for a while there is still residual charge. Therefore, if you remove boards in this state, it can cause a blown fuse or memory failure.

--How to remove the residual charge inside the machine--

After you unplug the power cord from the AC wall outlet, in order to remove the residual charge from inside the machine, be sure to press the main power switch. Thus, the charge remaining in the machine is released, and it is possible to remove boards.

##### **When you reconnect the AC power cord into an AC wall outlet, the machine will start automatically.**

In order to remove the residual charge, push the main power switch while you disconnect the AC power cord. At that time, the power ON flag inside the machine is set. Therefore, after you finish work on the machine and reconnect the power cord to the AC, even if you do not press the main power switch, the machine will start automatically and the moving parts will begin to move. When working on moving parts, be careful that fingers or clothes do not get caught.

#### Note

- Automatic restart deals with cases when you accidentally unplugged the AC power cord or unexpected power outages. By keeping the power flag ON, after the resumption of power, the

machine will start up automatically.

In rare cases, when you reconnect the AC power cord to a power outlet, the machine does not start automatically. In this case, the machine has not failed. The cause is due to the timing of releasing the residual charge. If you press the main power switch while the residual charge was already released, the power ON flag will not be set. At this time, start the machine manually by pressing the main power switch.

### Shutdown Method

---

1. Press the main power switch [A] on the left side of the machine.



2. The shutdown message appears. After the shutdown process, the main power is turned off automatically. The LED on the operation panel is turned off when the machine completes the shutdown.

#### **CAUTION**

Before attempting to remove or adjust any boards, follow the procedure below to obviate the need for replacing the board which may get damaged by the residual charge.

1. After shutdown, unplug the power cord.
2. Press and hold the power button for a second to discharge the residual charge.

### How to start from shutdown

To start the machine, press the main power switch. However, if you press the main power switch between the beginning and the end of a shutdown, the machine will not start.

### Forced Shutdown

---

In case normal shutdown does not complete for some reason, the machine has a forced shutdown function.

To make a forced shutdown, press and hold the main power switch for 6 seconds.

In general, do not use the forced shutdown.

#### **Important**

- Forced shutdown may damage the hard disk and memory, and can cause damage to the machine. Use a forced shutdown only if it is unavoidable.

## 4.Replacement and Adjustment

### Beforehand

#### CAUTION

- Turn off the main power switch and disconnect the power cord.
- After replacement, make sure that all removed harnesses are connected again and secured in their clamps.

#### Important

- Always touch a grounded surface to discharge static electricity from your hands before you handle SD cards, printed circuit boards, or memory boards.

## Special Tools

The following special tools should be prepared for maintenance of this machine in the field.

U: Unique for this machine

C: Common with listed machine

No.	Part Number	Description	Q'ty	Unique or Common
1	B6455030	SD Card 2GB	1	C (General)
2	B6455040	SD Card 8GB	1	C (General)
3	B6455060	SD Card 16GB	1	C (General)
4	M0CJ7490	Color Calibration Sheet	1	U
5	VSSG9005	MOLYKOTE EM-50L (Grease)	1	C (General)

### Note

- A PC is required for creating the Encryption key file on an SD card when replacing the controller board (PCB3) for a model in which HDD encryption has been enabled.
- 16GB SD card is necessary to capture the debug logs from 16S and later models except for Griffin-C2.

## Image Adjustment

### Printing

**Note**

- Make sure the paper is set correctly in each paper tray before you start these adjustments.
- Use Trimming Area Pattern (SP2-109-003, No.14) to print the test pattern for the following procedures.
- Set SP2-109-003 to "0" again after completing these printing adjustments.

### Registration: Leading Edge/Side-to-Side

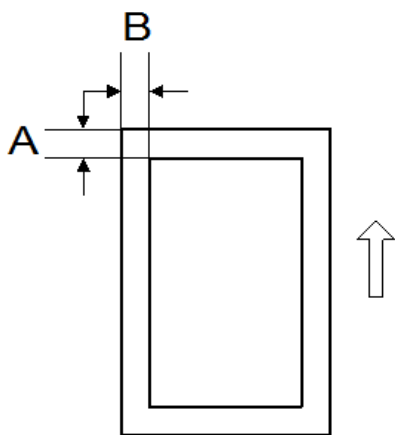

A: Leading Edge Registration

B: Side-to-side Registration

1. Check the leading edge registration [A] for each paper feed station, and adjust them using SP1-001.

Paper Feed Station	SP No.	Adjustment Range
Tray 1 (Main unit)	SP1-001-002	4.2 ± 2.0 mm
Tray 2 (Optional tray)	SP1-001-003	
Tray 3 (Optional tray)	SP1-001-004	
Tray 4 (Optional tray)	SP1-001-005	
Bypass Tray	SP1-001-001	
Duplex	SP1-001-011	

## 4.Replacement and Adjustment

Check the side-to-side registration [B] for each paper feed station, and adjust them using SP1-002.

Paper Feed Station	SP No.	Adjustment Range
Tray 1 (Main unit)	SP1-002-002	4.2 ± 2.0 mm
Tray 2 (Optional tray)	SP1-002-003	
Tray 3 (Optional tray)	SP1-002-004	
Tray 4 (Optional tray)	SP1-002-005	
Bypass Tray	SP1-002-001	4.2 ± 3.0 mm
Duplex	SP1-002-011	Duplex back side: Front side ± 1.0 mm

### Blank Margin

If the leading edge/side-to-side registration cannot be adjusted within the specifications, adjust the leading/left side edge blank margin.

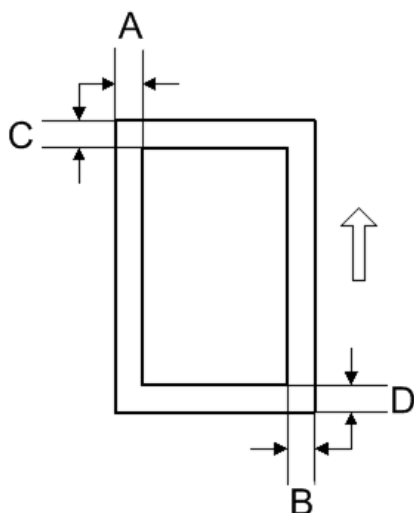

A: Left Edge Blank Margin

B: Right Edge Blank Margin

C: Leading Edge Blank Margin

D: Trailing Edge Blank Margin

1. Check the left edge [A], right edge [B], leading edge [C], trailing edge [D] blank margins, and adjust them using the following SP modes.

Edge	SP No.	Adjustment Range
Left Edge	SP2-103-003	Paper trays: 4.2 ± 2.0 mm, bypass tray: 4.2 ± 3.0 mm
Right Edge	SP2-103-004	
Leading Edge	SP2-103-001	4.2 ± 2.0 mm
Trailing Edge	SP2-103-002	

### Main Scan Magnification

1. Use SP2-109-003, No.5 (Grid Pattern) to print the single-dot grid pattern.
2. Check the magnification, and adjust the magnification using SP2-102-001 (Magnification)

#### 4.Replacement and Adjustment

Adjustment Main Scan) if necessary. The specification is  $\pm 0.80 \%$ .

## SMC Storage

The SMC report provided with the machine needs to be stored with the machine.

The factory SP settings are recorded in the SMC report. This report may be required after replacing the NVRAMs to set the SP settings to factory default.

1. Remove the HDD cover.

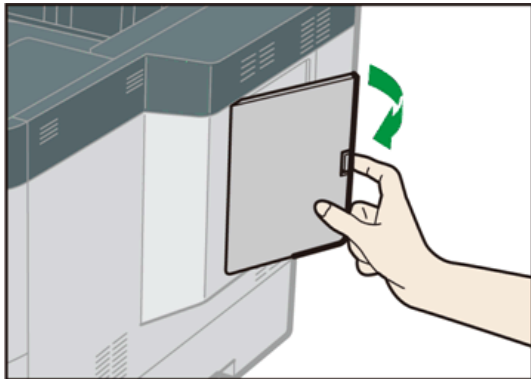

m0cja0027

2. The SMC report [A] is stored in the storage space on the back side of the HDD cover.



m0cja0028

## External Covers

---

### Front Cover

---

1. Lift the handle [A] and open the top tray [B].

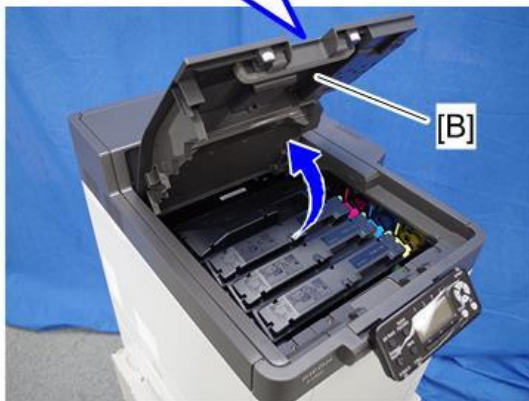

m0cja0050

2. Open the bypass tray [A].
3. Open the waste toner cover [B].



m0cja0051

## 4.Replacement and Adjustment

- 4.** Tilt the operation panel [A] to a vertical position and remove the cover [B].

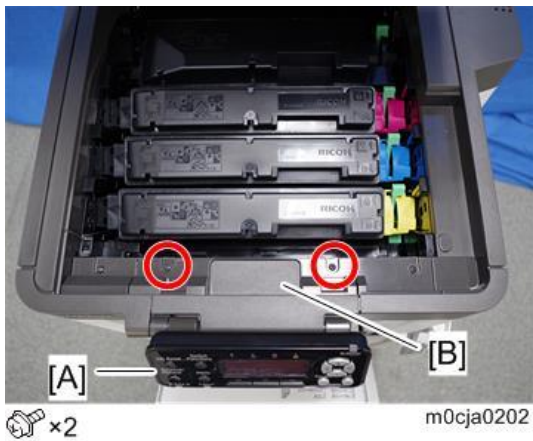

- 5.** Remove two screws.
- 6.** Tilt the operation panel [A] to a horizontal position and slightly lift up the front cover [B] to release the bosses and hook.

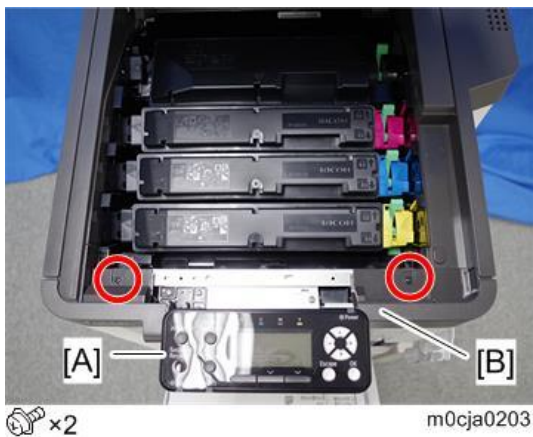

### Note

Check the position of the bosses and hook in the photo below before removing.

#### 4.Replacement and Adjustment

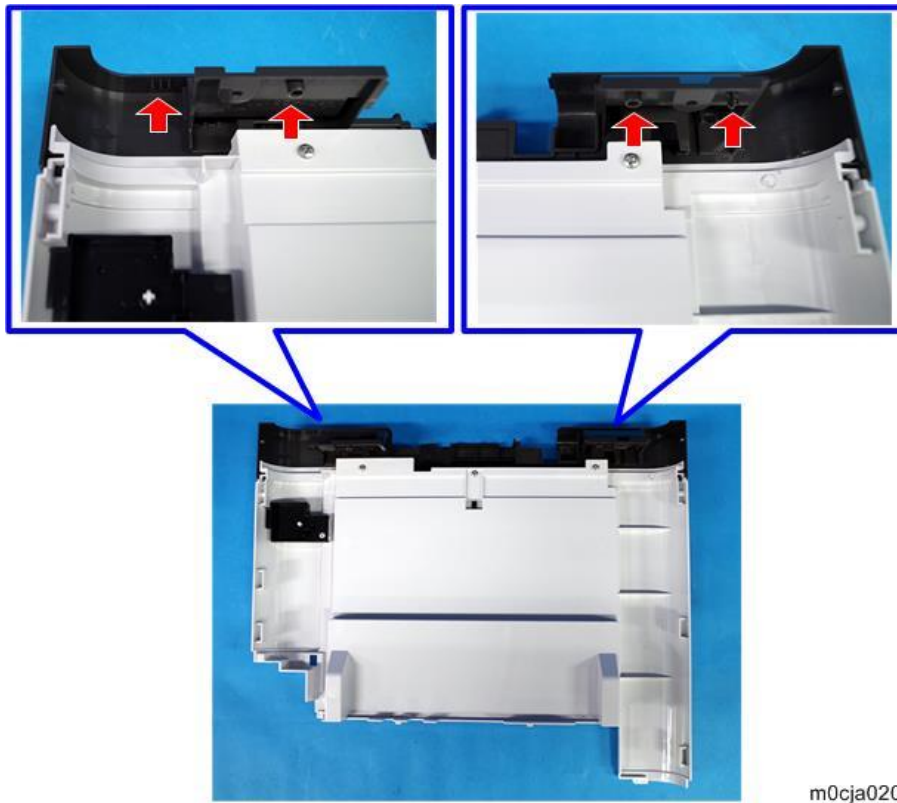

7. Tilt the front cover [A] toward the machine front side, and then remove it by lifting it up.



**★ Important**

Make sure not to touch the waste toner cover sensor (S3) (b) when reattaching the front cover (a). If the waste toner cover sensor (S3) (b) comes off, even if you close the waste toner cover, "cover open" will be displayed.

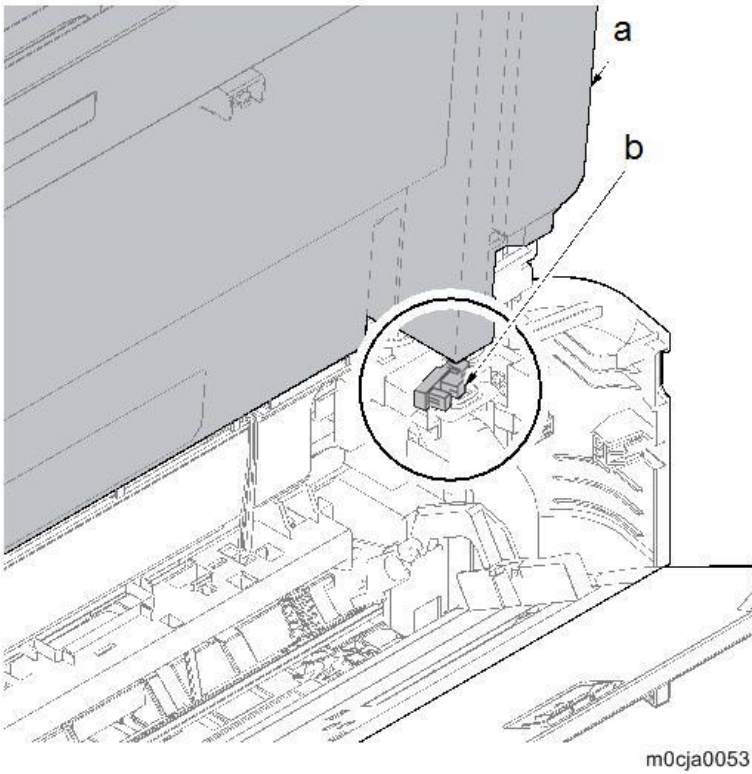

---

## Interface Cover

---

- 1.** Remove the upper right cover. ([Upper Right Cover](#))
- 2.** Remove the interface cover [A].

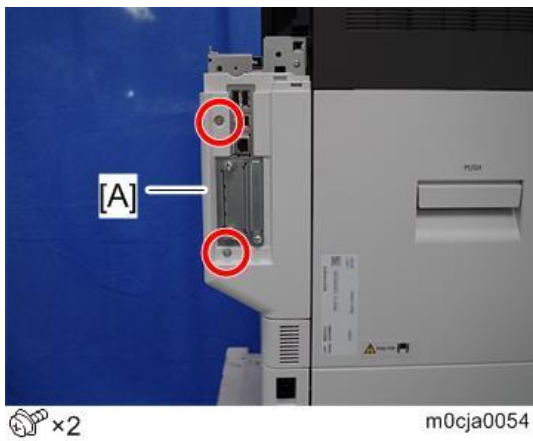

## 4.Replacement and Adjustment

---

### Upper Right Cover

---

1. Slide the upper right cover [A] toward the machine rear side and remove it.

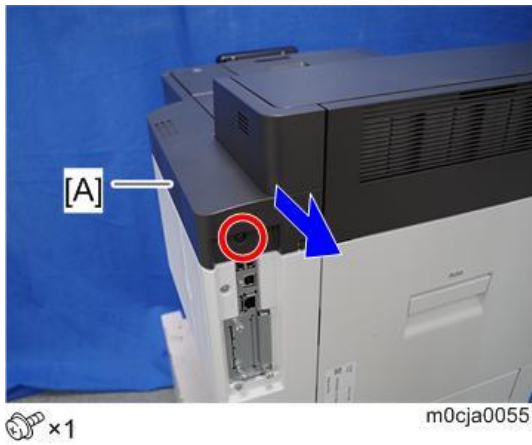

#### Note

Check the position of the hooks in the photo below before removing.

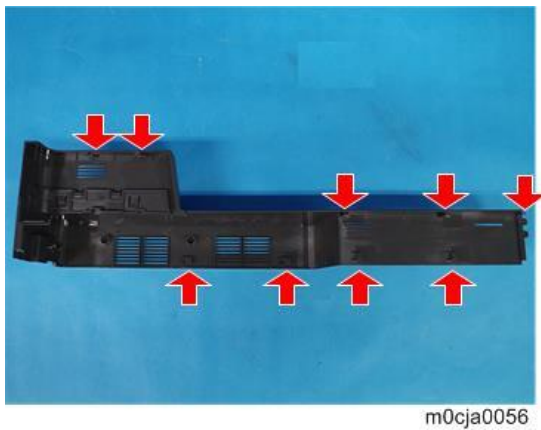

---

### Middle Right Cover

---

1. Remove the interface cover. ([Interface Cover](#))
2. Open the waste toner cover (a).
3. Press the arm (b) down.

- 4.** Remove the waste toner cover (a).

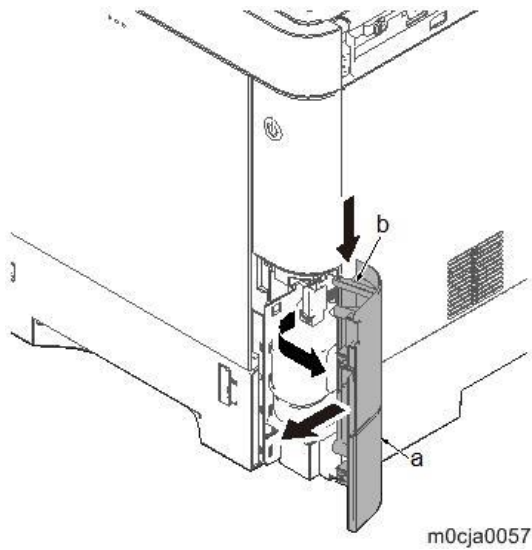

- 5.** Push the lever [A] and remove the HDD cover [B].

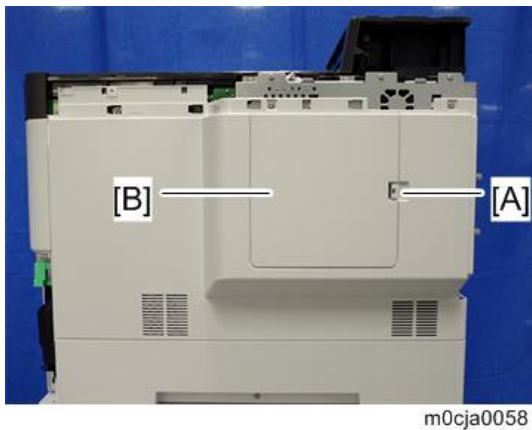

- 6.** Pull up the shield lid [A] and pull it toward you to remove it.

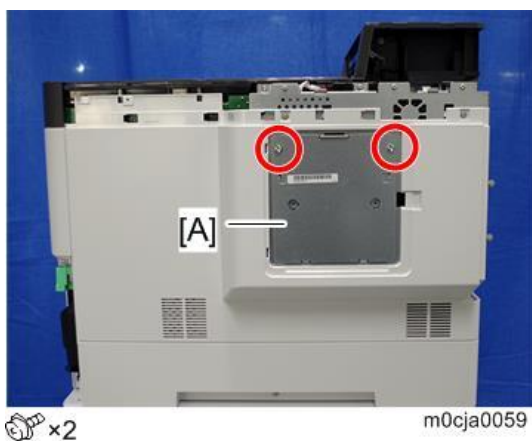

- 7.** Push the machine front side of the middle right cover [A] toward the machine rear side and then lift

## 4.Replacement and Adjustment

up its machine rear side to detach it.

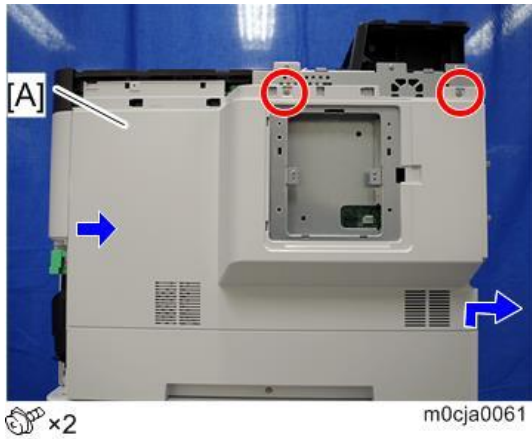

### Note

Check the position of the hooks in the photo below before removing.

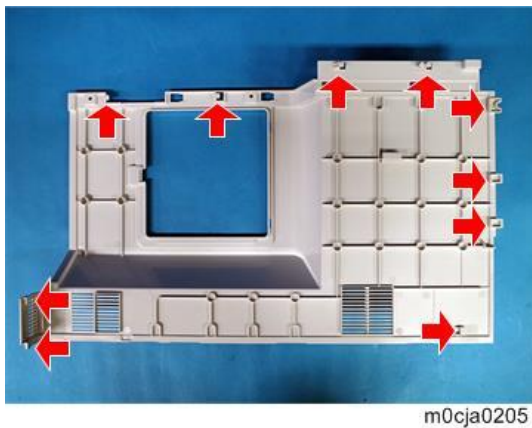

### Reinstalling the middle right cover:

- 1.** Insert the lower rib of the middle right cover into the the lower right cover with the middle right cover displaced about 2 cm to the back side of the machine.
- 2.** Insert the shaft of the waste toner cover.
- 3.** Press the middle right cover against the machine and slide it to the left.
- 4.** Push down the bottom right part of the middle right cover.

---

### Lower Right Cover

---

- 1.** Remove the middle right cover. ([Middle Right Cover](#))
- 2.** Remove the screw (a)(M3x8).
- 3.** Release the hook (c) of the lower right cover (b) toward the machine right side and slide it toward

the machine rear side to detach it.

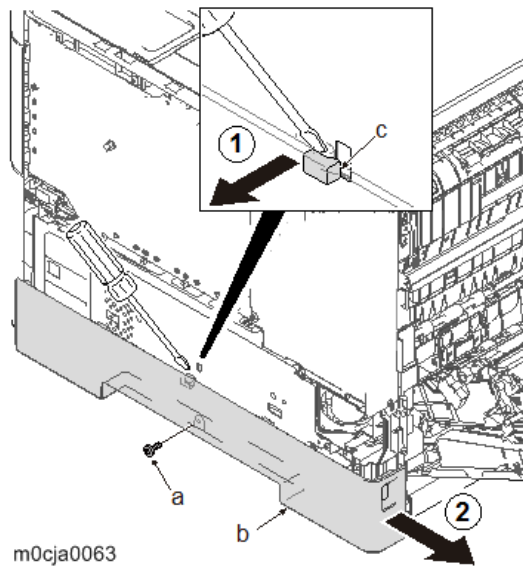

---

### Upper Left Cover

---

**1.** Open the rear cover (a).

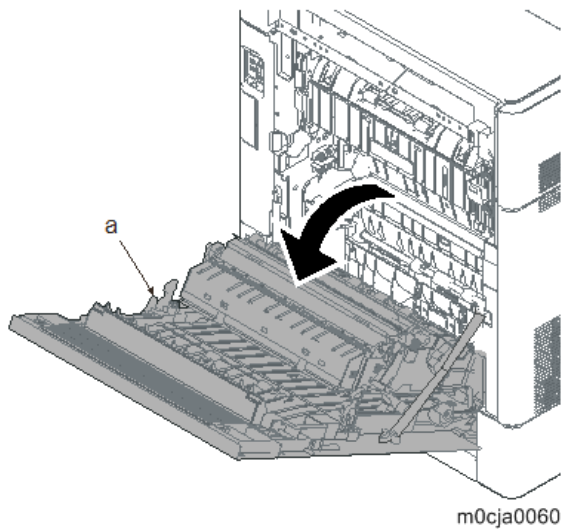

**2.** Remove two screws (a)(M3x8).

## 4.Replacement and Adjustment

3. Slide the upper left cover (b) toward the machine rear side and detach it.

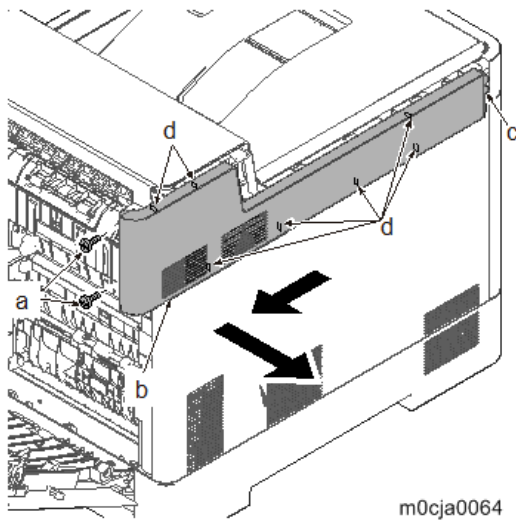

### ★ Important

When reattaching the upper left cover (b), insert the hook (c) to the machine front side, and then fasten seven hooks (d) by sliding it toward the machine front side.

---

## Middle Left Cover

---

1. Remove the upper left cover. ([Upper Left Cover](#))
2. Lift up the machine rear side of the middle left cover (a) to release three hooks (b).
3. Slide the middle left cover (a) toward the machine rear side to release two hooks (c).
4. Detach the middle left cover (a).

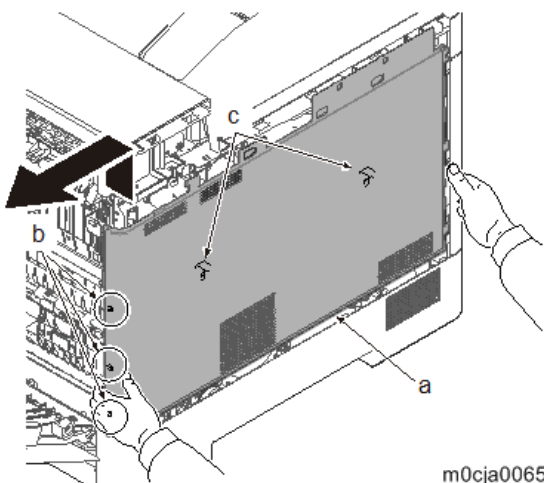

### ★ Important

When reattaching the middle left cover (a), insert the lower rib into the lower left cover (b). Slide it toward the machine front side to fasten three hooks (c) and four hooks (d), then lower the machine rear

side of it to fasten three hooks (e) at the machine rear side.

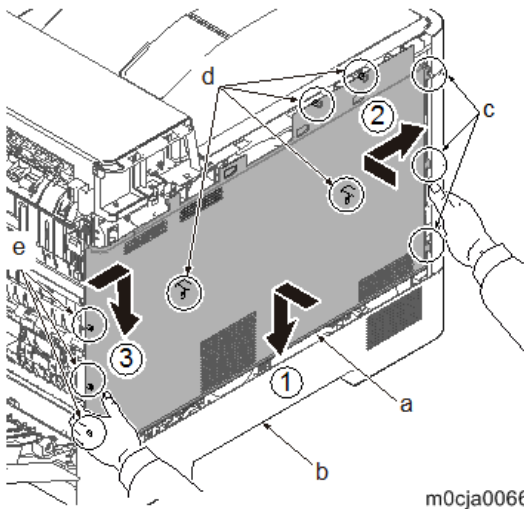

### Lower Left Cover

- 1.** Remove the middle left cover. ([Middle Left Cover](#))
- 2.** Remove the screw (a)(M3x8).
- 3.** Pull the rib (b) toward the machine front side and release the center hook (c).
- 4.** Release the hook (c) using a flat-blade screwdriver.
- 5.** Detach the lower left cover (d).

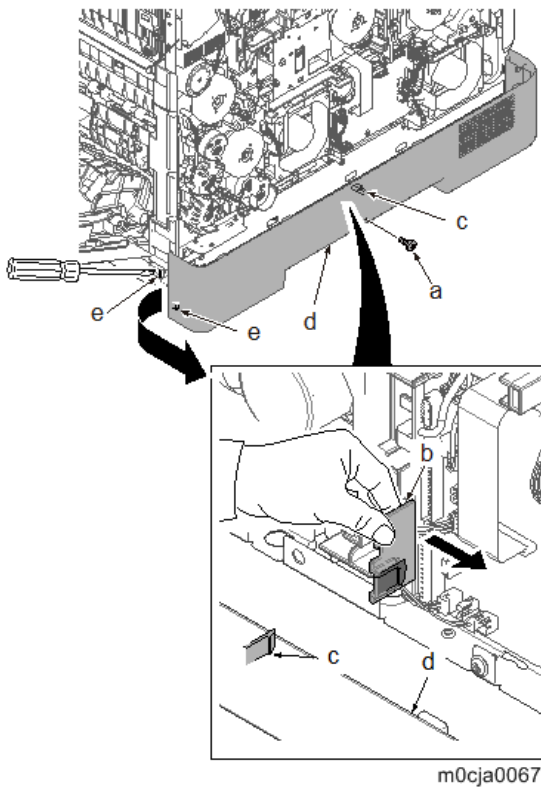

## 4.Replacement and Adjustment

### ★ Important

When attaching the lower left cover (a), insert two bosses (b) at the machine front side into the holes and apply the center hook (c). Then, attach it with the screw.

Check if the hook at the center is surely fastened.

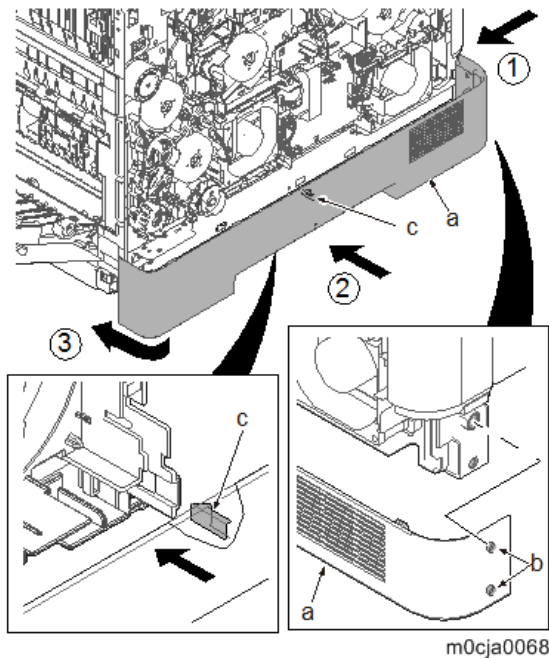

---

## Rear Cover

---

1. Open the rear cover (a).

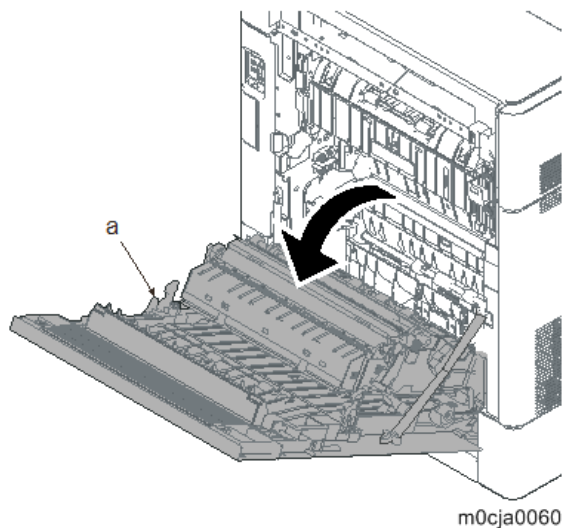

2. Close the duplex conveying unit (a).

**3.** Remove two straps (c) of the rear cover (b).

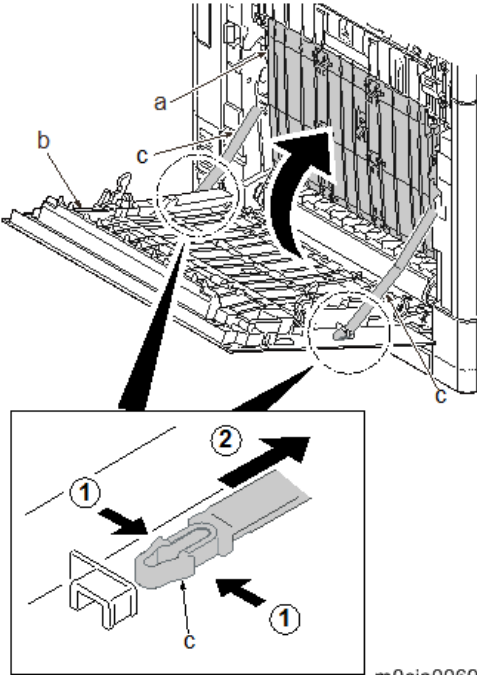

m0cja0069

**4.** Align the rear cover in the direction of the arrow, then release the fulcrum parts (b) and (c), and remove the rear cover (a).

To remove the fulcrum pin, first spread out the frame on the side (b) by pushing the rear cover inward with a flathead screwdriver.

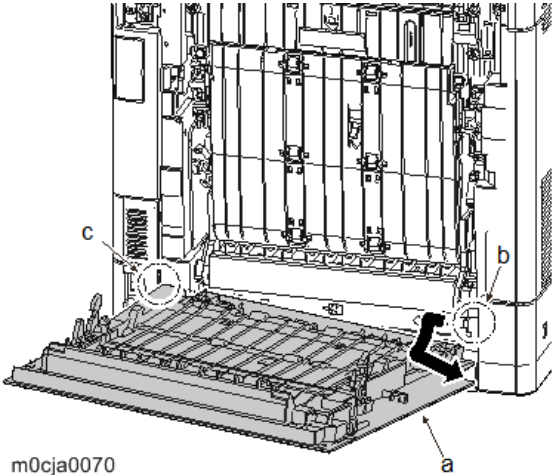

m0cja0070

## 4.Replacement and Adjustment

### Operation Panel

1. Remove the front cover. ([Front Cover](#))
2. Remove the operation panel [A] from the mainframe.

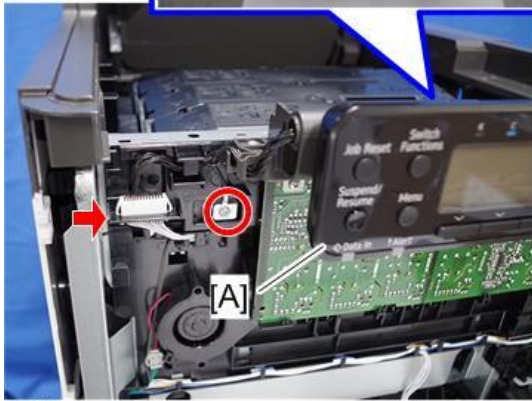

 x6  x1

m0cja0206

## Laser Unit

### ⚠ CAUTION

- Turn off the main power switch and unplug the machine before beginning any of the procedures in this section. Laser beams can cause serious eye injury.

---

### Caution Decal Locations

---

Caution decals are attached as shown below.

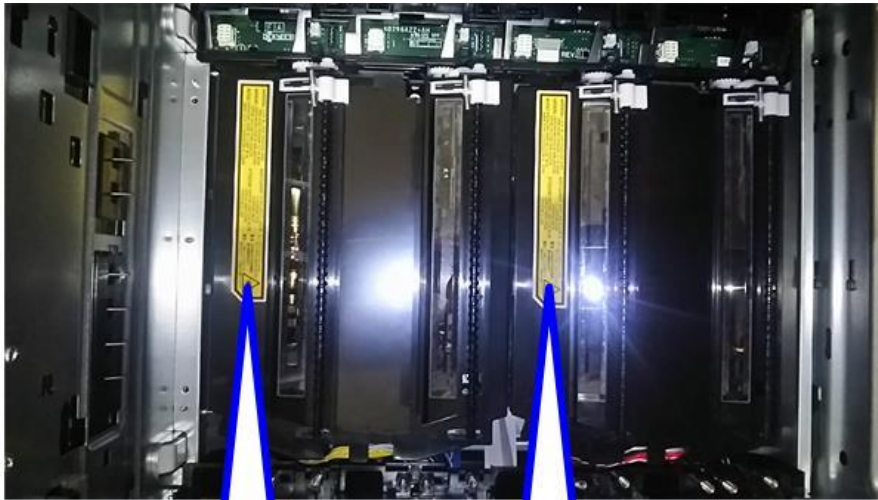

m0cja1046

### ⚠ WARNING

Be sure to turn off the main power switch and disconnect the power plug from the power outlet before beginning any disassembly or adjustment of the laser unit. This model uses the Class IIIb laser beam with a wavelength of 660 to 680 nm and an output of 32.5 mW. The laser can cause serious eye injury.

---

### Laser Unit

---

- 1.** Remove the development unit. ([Development Unit](#))
- 2.** Remove the controller box. ([Controller Box](#))

#### 4.Replacement and Adjustment

- 3.** Open the harness alignment film [A] by releasing two square holes [B] [C] from the hooks.

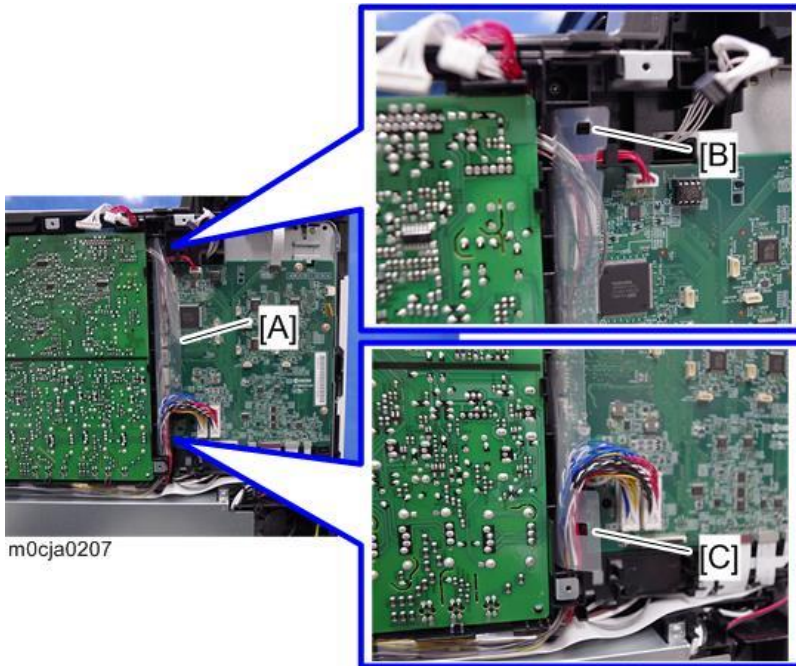

- 4.** Disconnect two connectors ([A]: YC2016 and [B]: YC2017) from the main/engine PCB (PCB1).  
**5.** Release the harnesses from the harness guide [C].

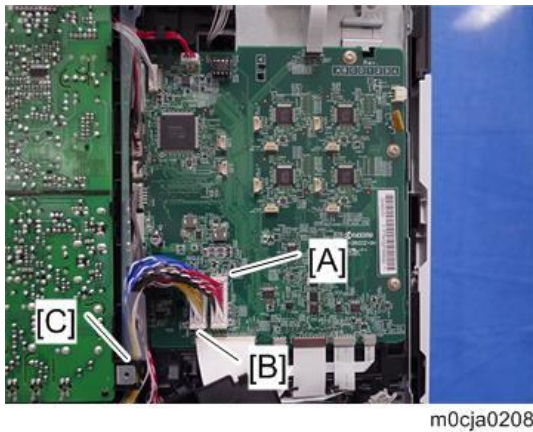

- 6.** When removing the laser unit (CY), open the film [A] after removing the connector YC2017.

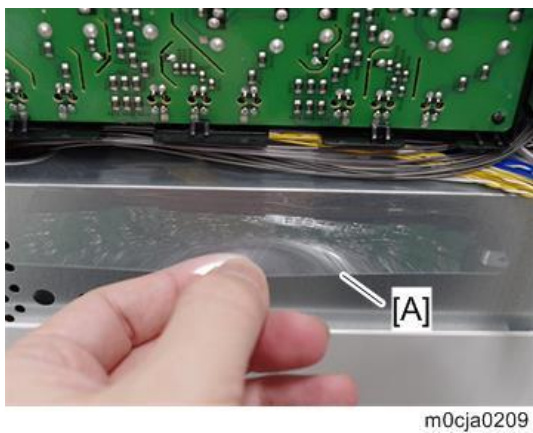

- 7.** Pull the harness [A] into the main unit from the opening [B].  
When removing the laser unit (KM):

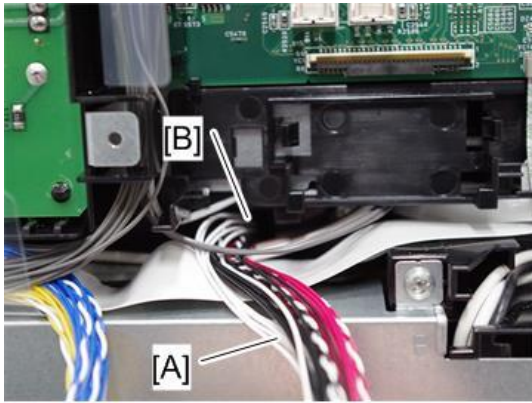

m0cja0210

When removing the laser unit (CY):

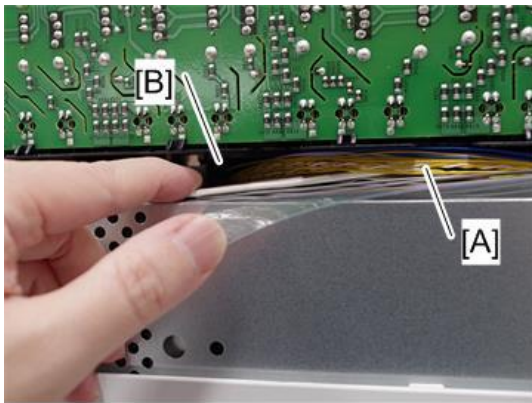

m0cja0211

- 8.** Remove the drum heater (K, M, C and Y), if installed.

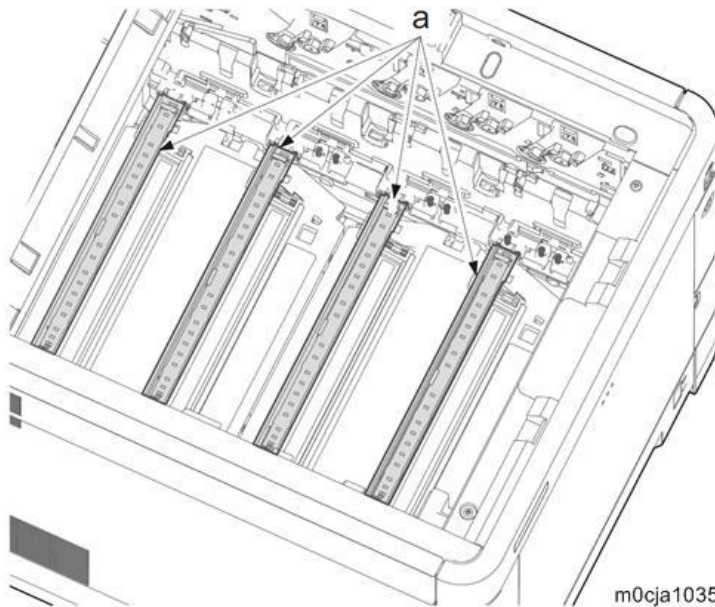

m0cja1035

1. Disconnect the connector (b) of the drum relay PCB (PCB22) (a).

#### 4.Replacement and Adjustment

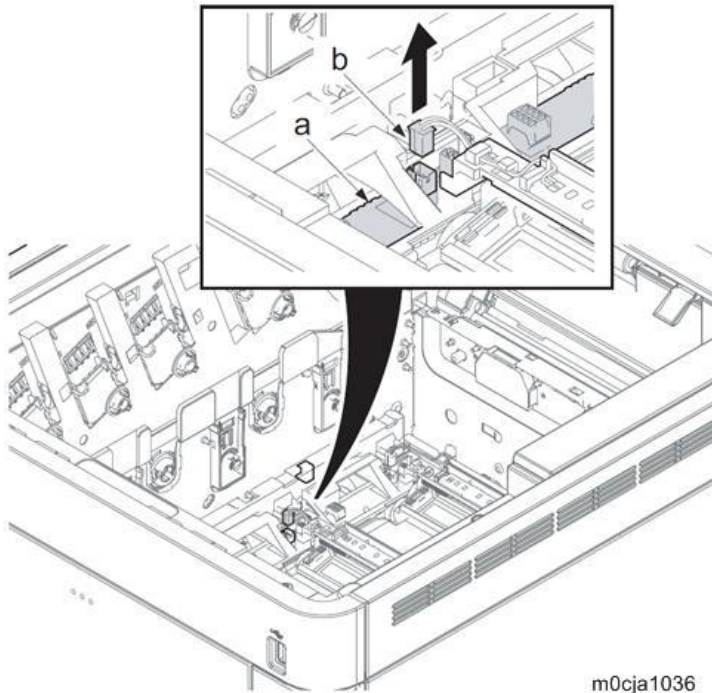

m0cja1036

2. Lift up the machine left side of the drum heater (a) to remove the pin (b) from the boss.

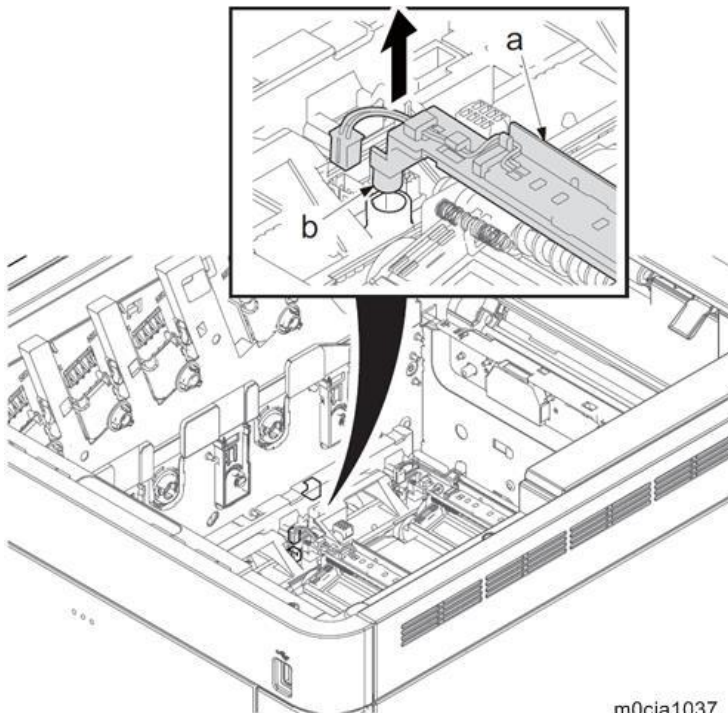

m0cja1037

3. Slide the boss (b) at the machine right side of the drum heater (a) to remove it.

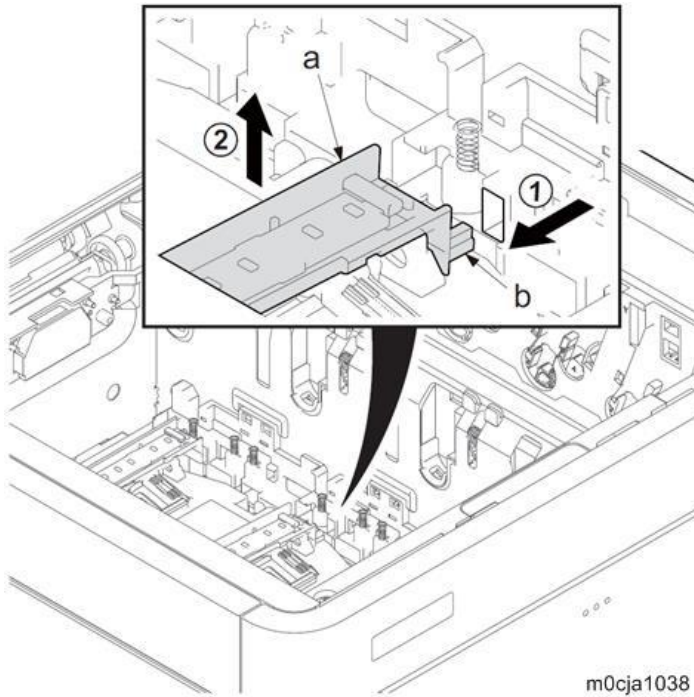

**Note**

Like this, remove four drum heaters (a).

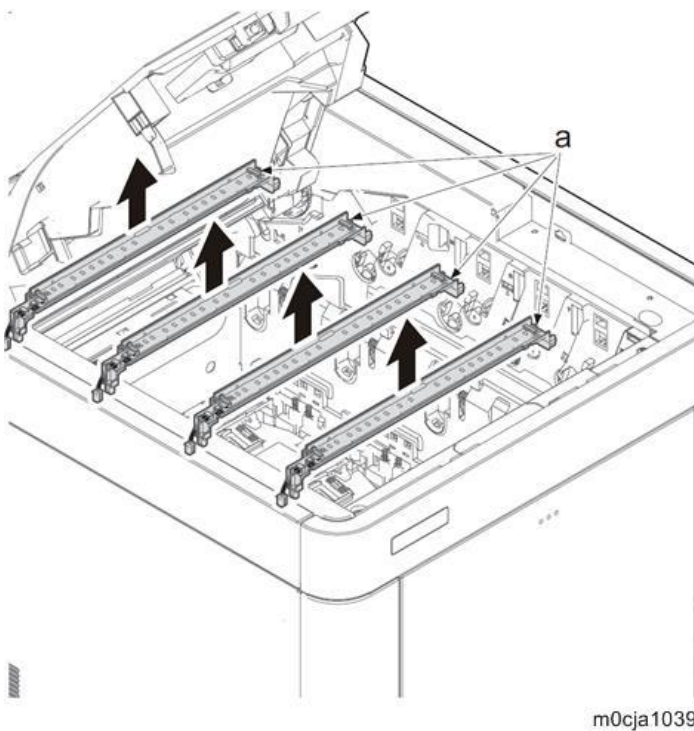

**9.** Remove each set of three pins (a).

**10.** Detach the laser units (b) for KM and CY.

**Note**

Pull out the harness from the opening and remove it.

#### 4.Replacement and Adjustment

- 11.** Check the laser unit and clean or replace it if necessary.
- 12.** Reattach the parts in the original position.
- 13.** Execute the following after replacing with the new laser unit.

System Menu

[Adjustment/Maintenance]

- 1. Executes Color adjustment (Color Calibration).
- 2. Execute the Color Registration.

**★ Important**

Secure the pins in order of A, B and C when reattaching the laser unit.

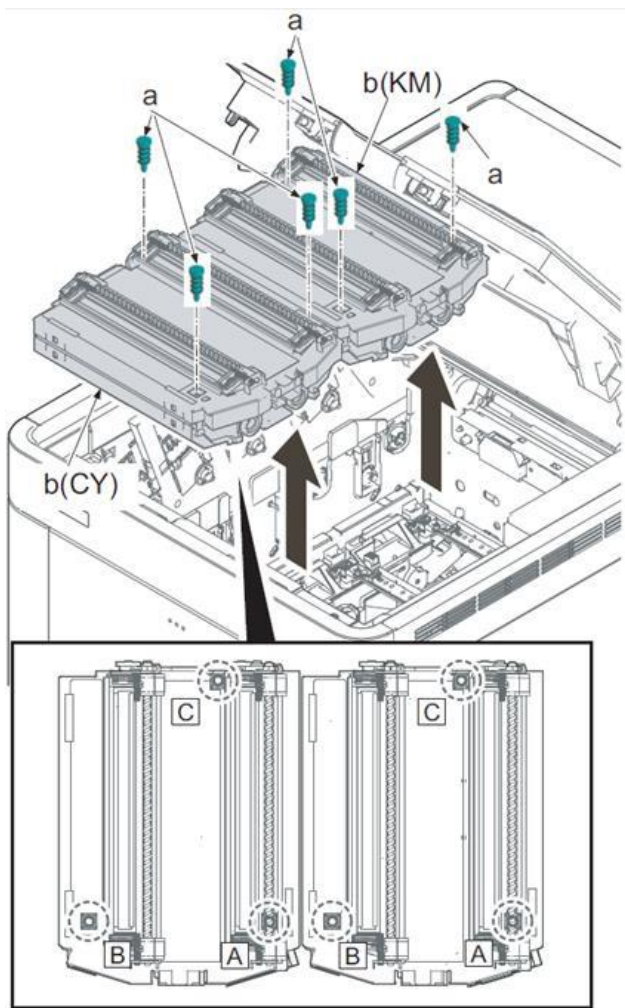

m0cja1040

**★ Important**

- Make sure to return the spiral (b) to the lock position after relocating it to reattach the pin

(a) that is in the position A.

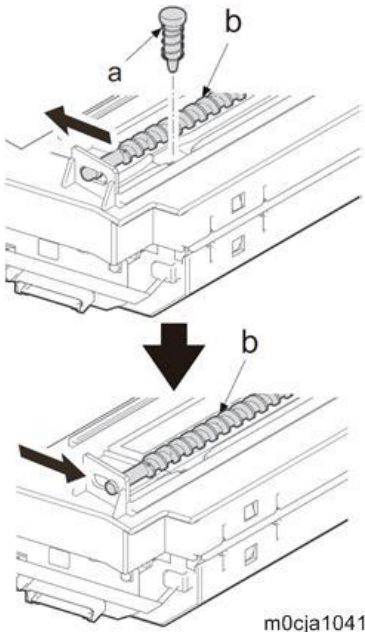

- Make sure not to touch the LDB (PCB12/PCB14/PCB16/PCB18) (b) when holding the laser unit (a).

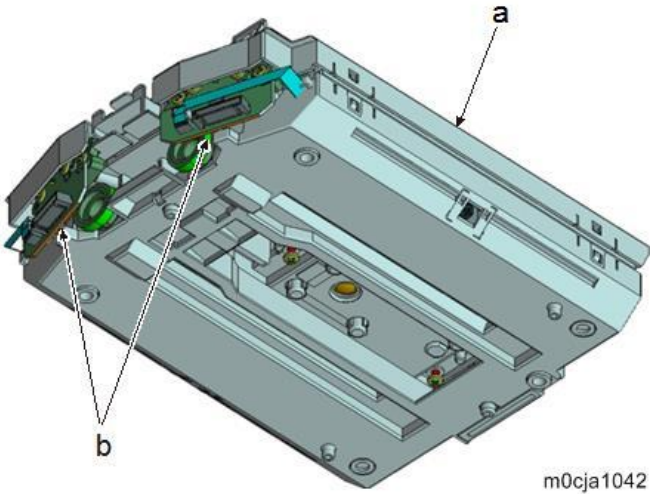

- Pull the harness (b) out from the aperture (c) of the frame when reattaching the laser unit

#### 4.Replacement and Adjustment

(a). There is an engraving (d) of an arrow indicating the opening position in the frame.

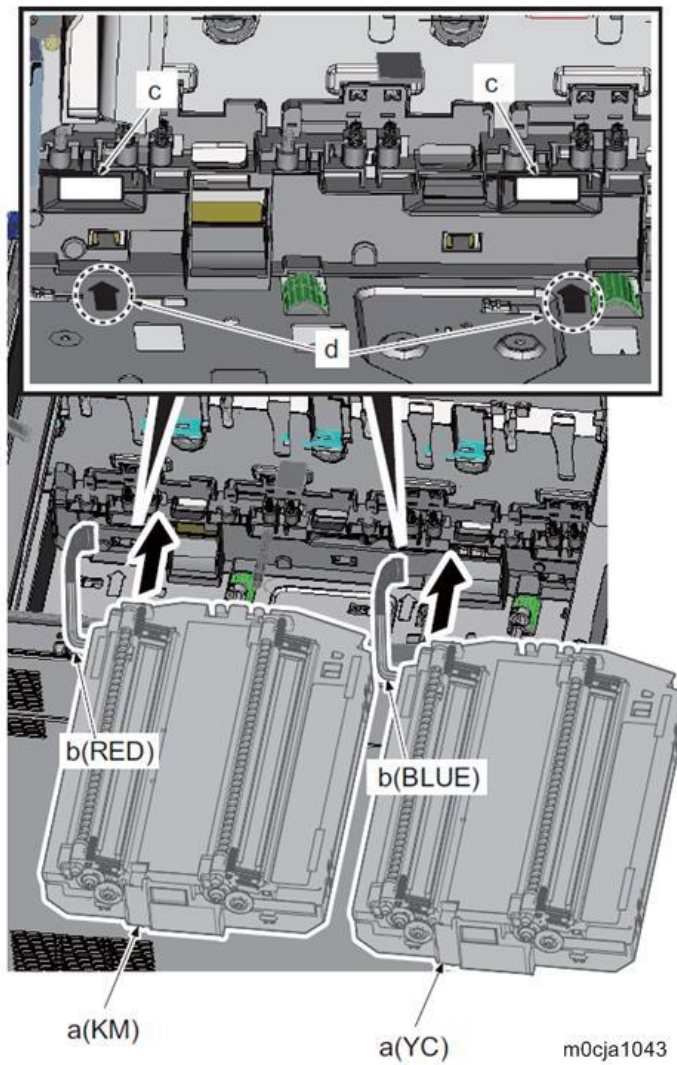

- Be careful not to locate the saddle clamp (b) on the pin protrusion (c) before reattaching

the laser unit (a).

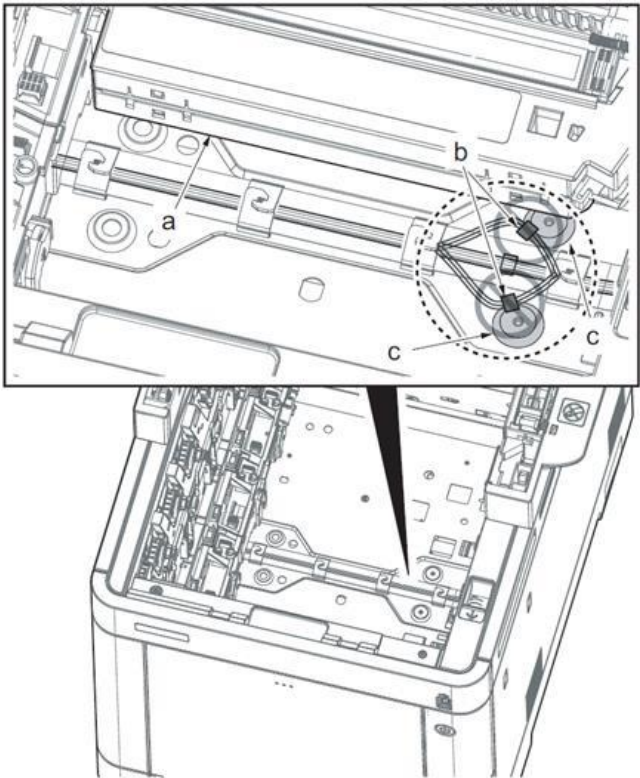

m0cja1044

## Development Unit

### Development Unit

---

1. Remove the Drum unit. ([Drum Unit](#))
2. Detach the development unit (K, M, C and Y)(a).  
\*: connection portion (b)

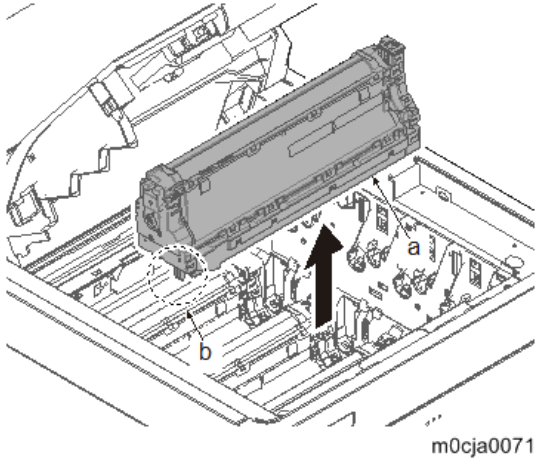

\*: When detaching the development unit (a), hold both the left and right handles (b).

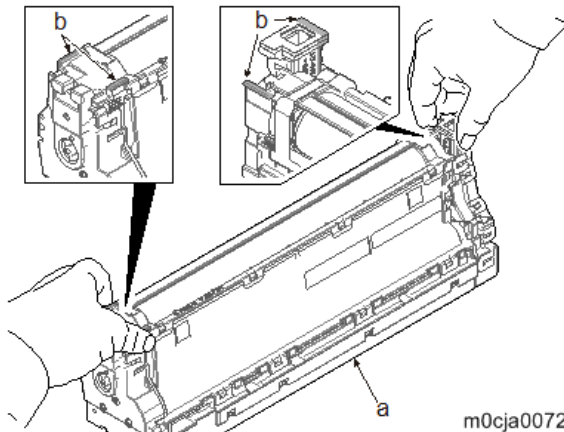

\*: Make sure not to touch the gears (a) in the drive section where there is grease.

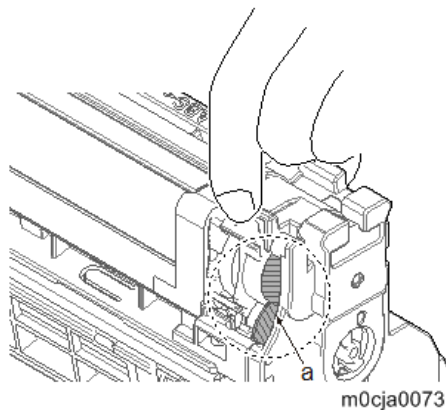

3. Detach the development unit (K, M, C and Y)(a).

**4.** Reattach the parts in the original position.

**★ Important**

When attaching the development unit (a), match the colors between the back side (b) of the development unit and the right side (c) of the main unit.

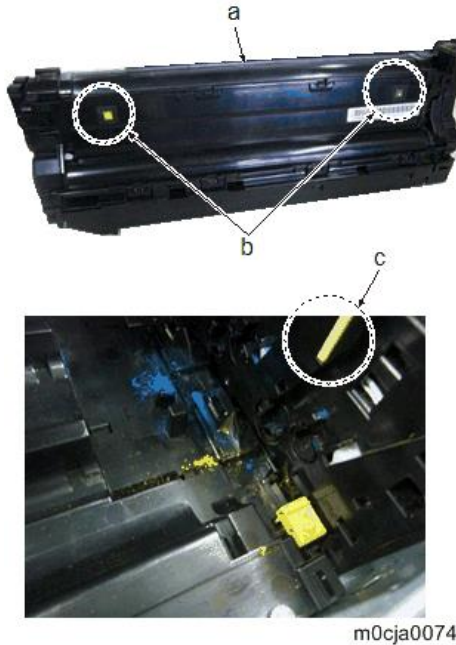

\*: Remove the cap (b) when attaching the new development unit (a).

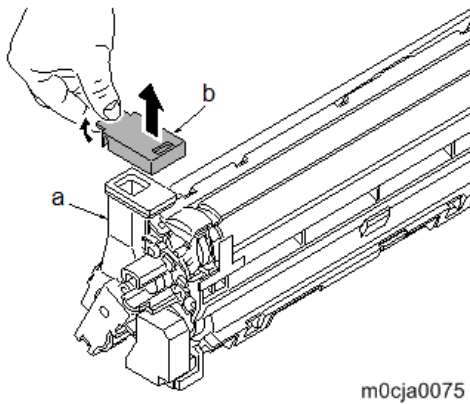

- 5.** Attach the new drum unit (K,M,C and Y).
- 6.** Reattach the parts in the original position.
- 7.** Attach the new ITB unit.
- 8.** Reattach the parts in the original position.
- 9.** Detach the toner cartridges (K, M, C and Y).
- 10.** Close the top tray.

After Replacement of Development Unit

---

- 1.** Execute SP3-900-001 to supply toner to the development unit.

## Drum Unit

### Drum Unit

1. Remove the ITB unit. ([Image Transfer Section](#))
2. Detach the drum unit (M,C and Y)(a) by pulling it up.  
Lift up the drum unit (K)(b) and pull it toward the machine front side to detach it.

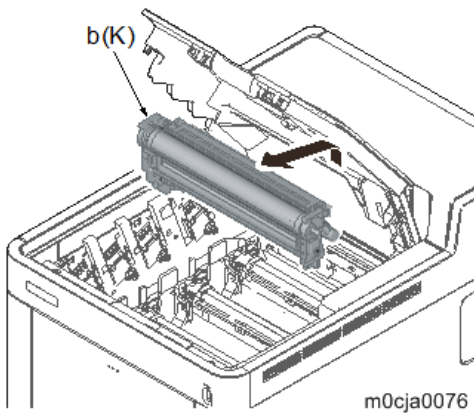
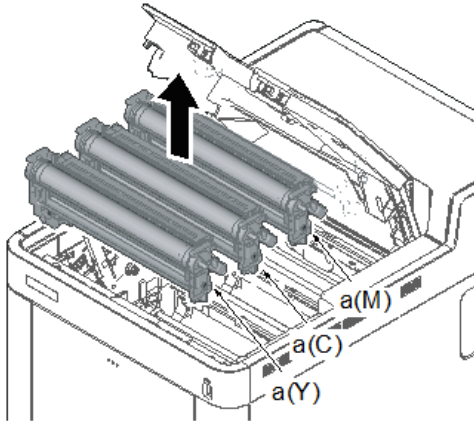

Hold the handles (b) on both sides when detaching the drum unit (a).

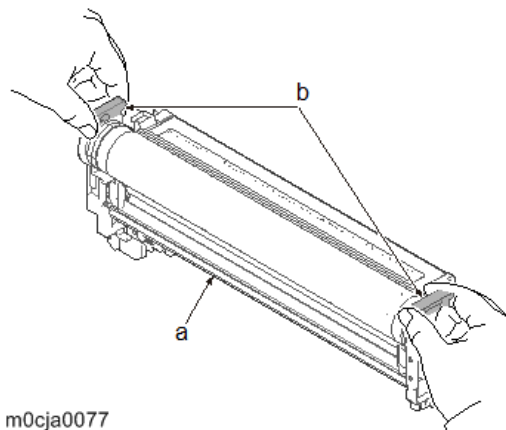

#### Note

- When attaching the drum unit, make sure to attach the drum unit (K) in the machine rear

## 4.Replacement and Adjustment

side and attach the drum unit (M, C and Y) in the same order as the color bars.

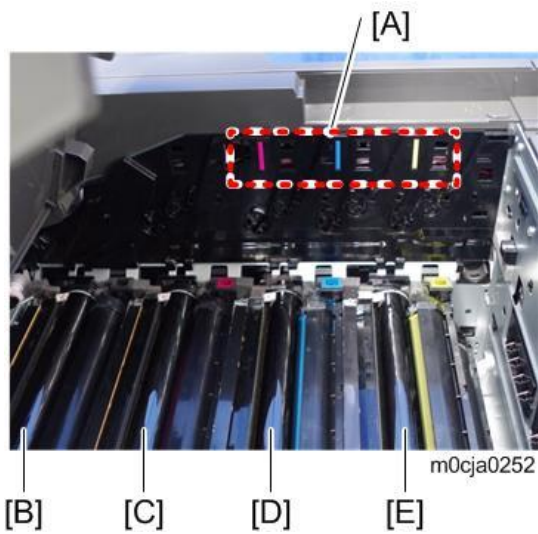

[A]: Color bars

[B]: Drum unit (K)

[C]: Drum unit (M)

[D]: Drum unit (C)

[E]: Drum unit (Y)

- When attaching the drum unit (K)(a), tilt it toward you to insert the drum shafts (b) along the

## 4.Replacement and Adjustment

rails (c) all the way. Then, make it vertical and push into the main unit.

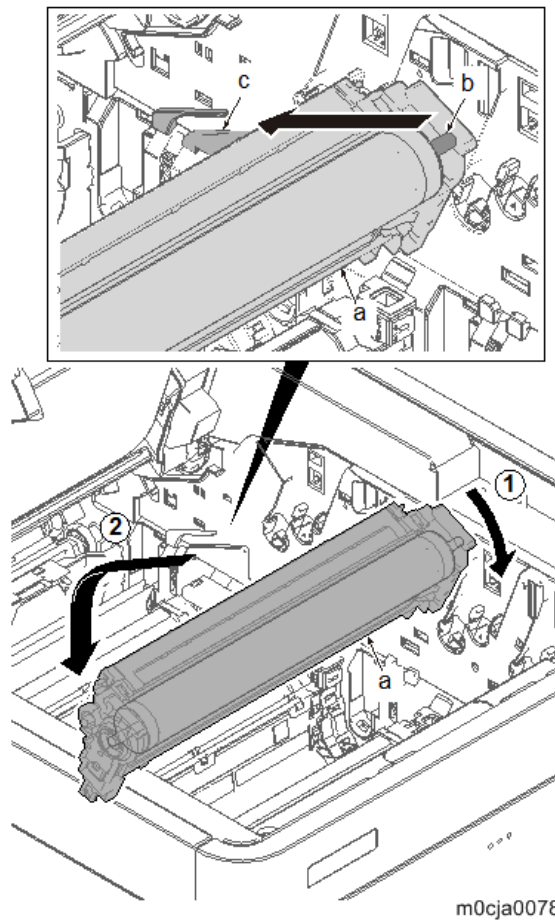

m0cja0078

---

### Charge Roller

---

1. Detach the drum unit (a).
2. Pull the hook (c) of the main charger roller unit (b) in the drum unit (a) to release it.

- 3.** Push the main charger roller unit (b) from the opposite side of the opening.

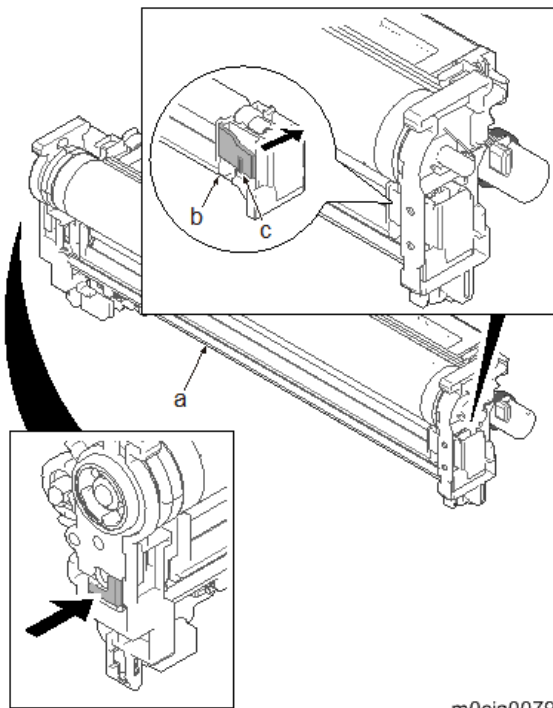

m0cja0079

- 4.** Pull the main charger roller unit (b) by holding the handle (a).

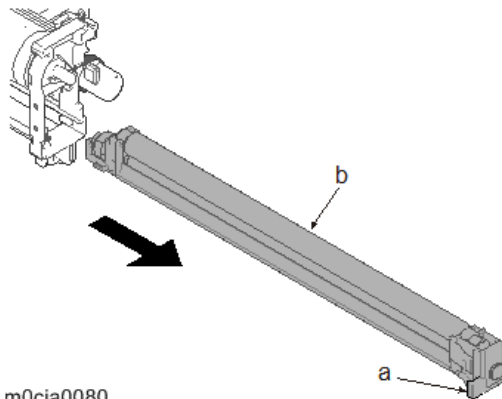

m0cja0080

## Transfer Unit

---

### Image Transfer Section

---

1. Lift the handle [A] and open the top tray [B].

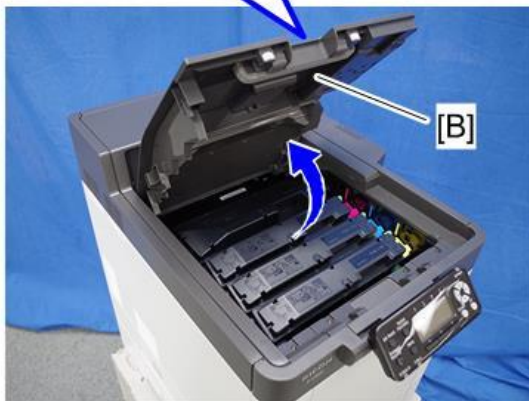

m0cja0050

2. Rotate the lock lever (a) of each toner cartridge.

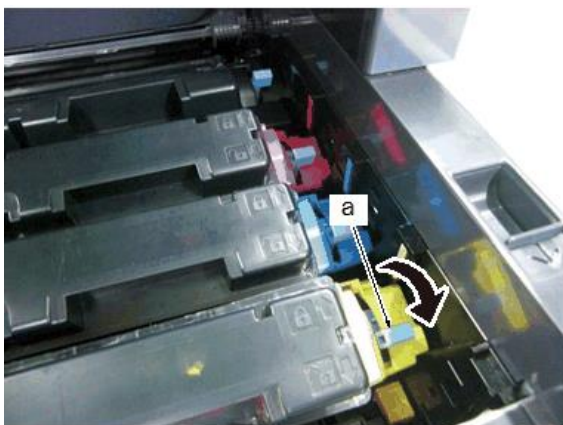

m0cja0081

- 3.** Detach the toner cartridges (K, M, C and Y) (a).

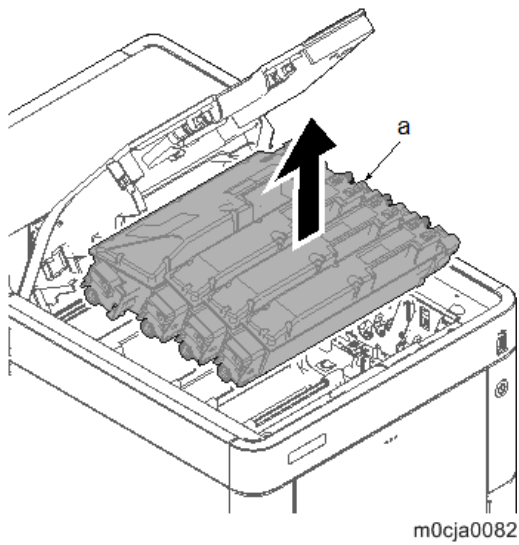

**Note**

When detaching the toner cartridge (a), first lift its handle (b) and then pull it out upward.

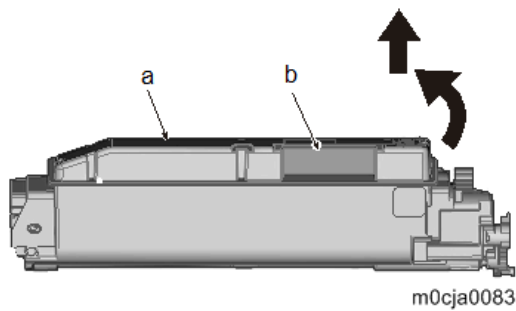

- 4.** Pull the right shutter lever (a) in the direction of the arrow.

**Note**

Close the toner feed inlet by pulling this lever.

This lever returns to the original position when the lock lever of the black toner cartridge is in the lock position after the ITB unit and the toner cartridges are installed.

#### 4.Replacement and Adjustment

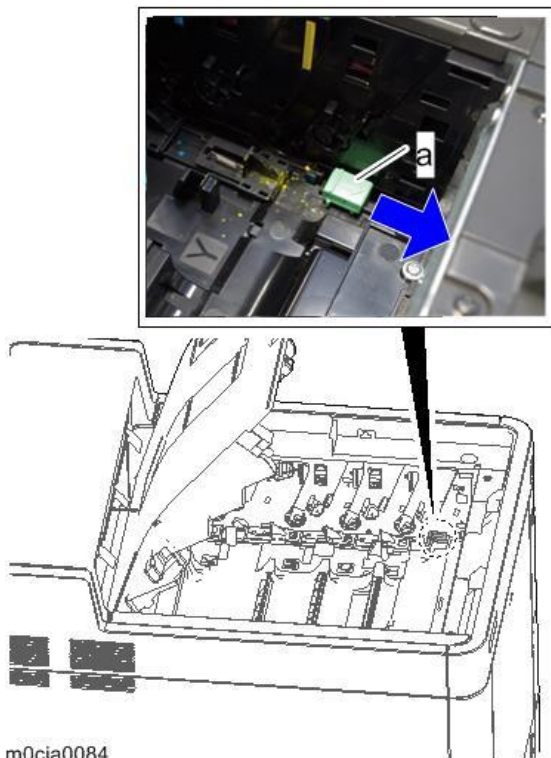

- 5.** Remove the screw (a) (M3x12).

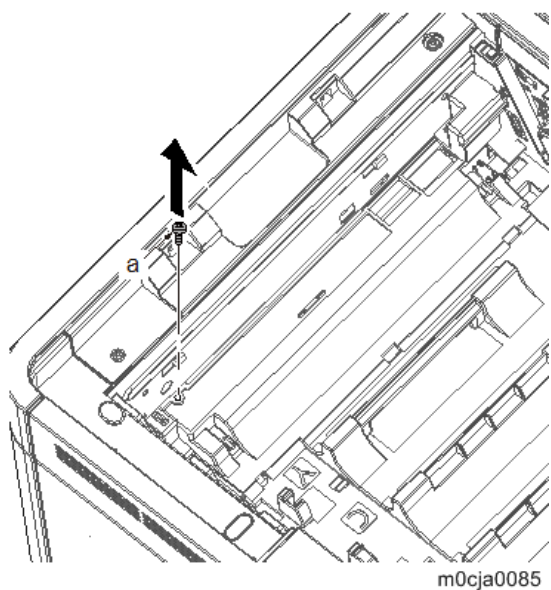

- 6.** Remove the screw (a) (M3x12).  
**7.** Remove the lever cover (b).  
**8.** Lift up the drive release lever (c).

**Note**

When raising the lever, the joint of the drive coupling is released.

**Important**

If omitting to attach the lever cover, "Cover open" message is displayed while the exit tray switch (SW2) is not turned on.

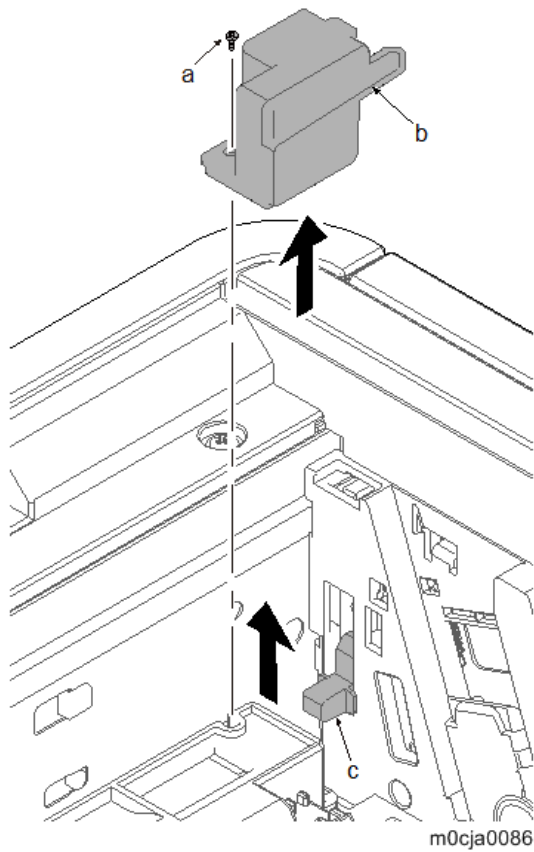

**9.** Hold the handle (a) and detach the ITB unit (b).

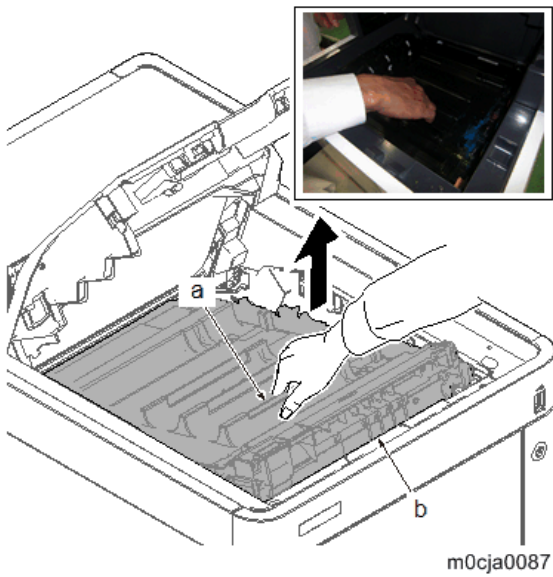

**Note**

- Hold the handle (b) at the machine front side and lift up the ITB unit (a). Then, further lift it up

#### 4.Replacement and Adjustment

and pull it toward the machine front side to detach.

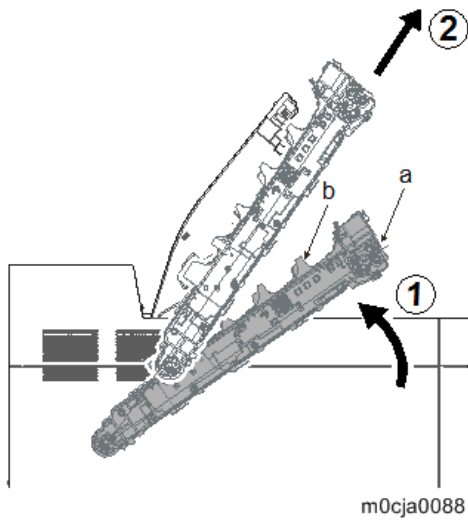

- When removing the ITB unit (a) or it is unstable to install it, hold the handle (b) at the machine rear side by the other hand.

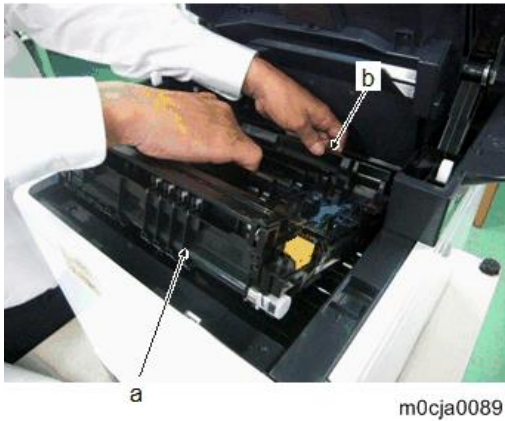

- Do not touch the release lever (b) after detaching the ITB unit (a). This lever (b) is connected with the shutter lever (c) and so they are released together by installing the toner cartridge into the main unit. The operation mistakenly open the toner feed inlet (d).

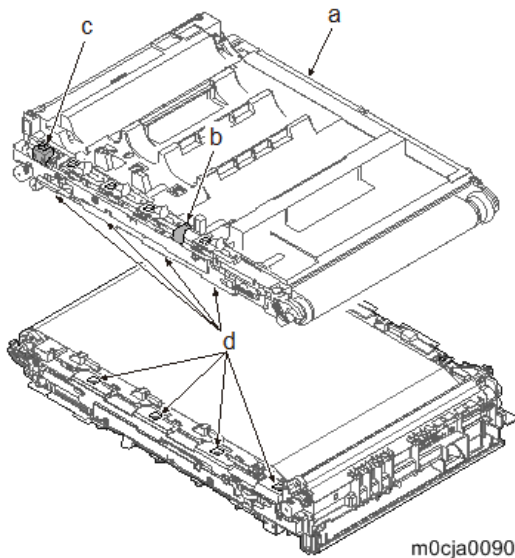

---

## Paper Transfer Roller Unit

---

- 1.** Release two hooks (b) of the duplex paper conveying unit (a).
- 2.** Detach the paper transfer roller unit (c).
- 3.** Attach the new paper transfer roller unit (c).
- 4.** Reattach the parts in the original position.
- 5.** Reattach the duplex conveying unit in the reverse order of removal.
- 6.** Close the rear cover.

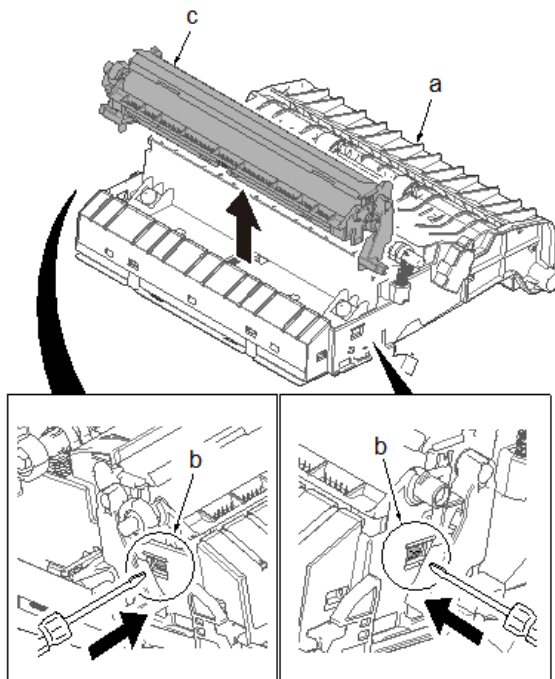

m0cja0091

**★ Important**

When reattaching the paper transfer roller unit (a), first fit the upper part and then insert the hook (b) into the square hole.

Then, insert each hook (c) of both transfer release levers into the inside ribs (d).

## 4.Replacement and Adjustment

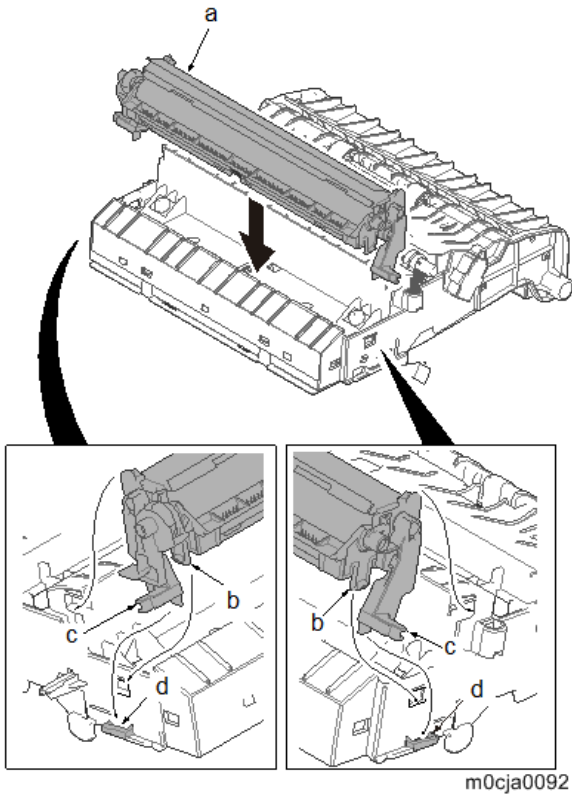

### Adjustment procedures after replacing the paper transfer roller unit

Execute the following procedures after replacing the paper transfer roller unit.

1. Execute the laser scanner cleaning  
[Maintenance] > [OK] key > [Quality Maintenance] > [OK] key > [Clean Laser Scanner Unit] > [OK] key
2. Execute the Color Calibration  
[Maintenance] > [OK] key > [Quality Maintenance] > [OK] key > [Color Calibration] > [OK] key > [Adjust Auto Density] > [OK] key
3. Execute the Color Registration  
[Maintenance] > [OK] key > [Quality Maintenance] > [OK] key > [Color Registration] > [OK] key > [Auto Adjust] > [OK] key

## Fusing Unit

### Fusing Unit

#### **⚠ CAUTION**

Fusing unit parts are very hot and may cause burn injury. Please wait after powering off the machine until it is cool to the touch before advancing.

- 1.** Remove the interface cover. ([Interface Cover](#))
- 2.** Remove the fusing wire cover [A].

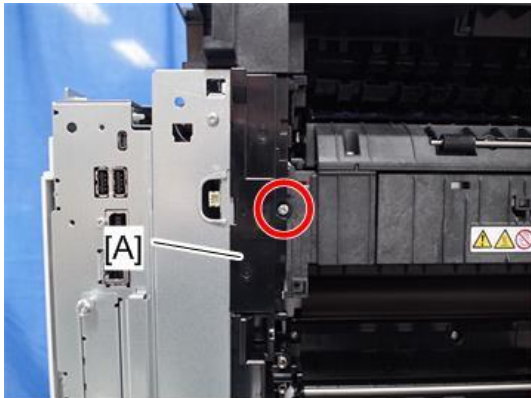

m0cja0212

- 3.** Disconnect two connectors.

\*: Disconnect each connector of the paper exit PCB (PCB8) (a) and the fusing heater (b).

Do not disconnect two connectors (c) of the fusing unit.

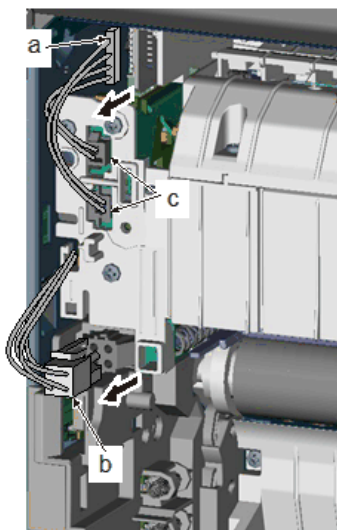

m0cja0094

- 4.** Remove two screws (a)(M3x8: silver).  
(Screws that are secured at the position with the triangle engraving.)
- 5.** Detach the fusing unit (b).
- 6.** Attach the new fusing unit.

## 4.Replacement and Adjustment

### 7. Reattach the parts in the original position.

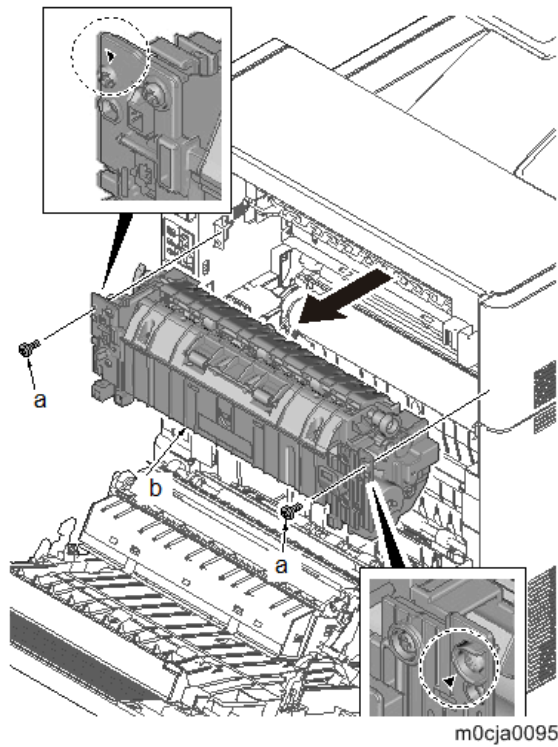

#### ★ Important

Take care not to touch the connector of the press-release sensor (S2) (b) when fitting the fusing unit (a). A service call error may appear if the sensor is disconnected.

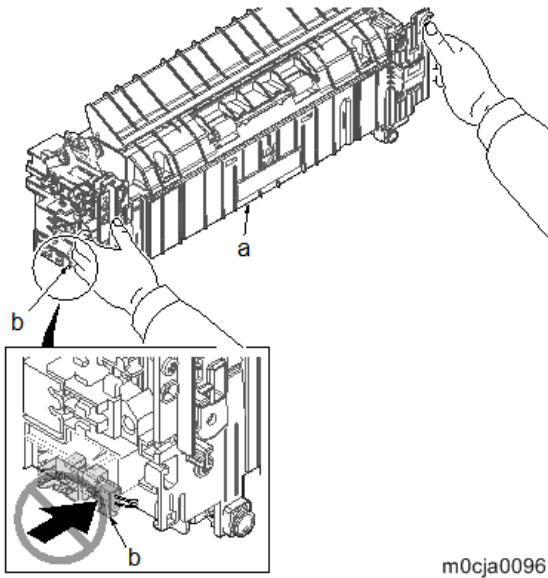

When attaching the fusing unit, first secure the screws and connect the connectors. (For prevention of damage from static-electricity)

Before reattaching the fusing wire cover, put the wire (a) in between the ribs (b) so that it is not caught by the fusing wire cover.

#### 4.Replacement and Adjustment

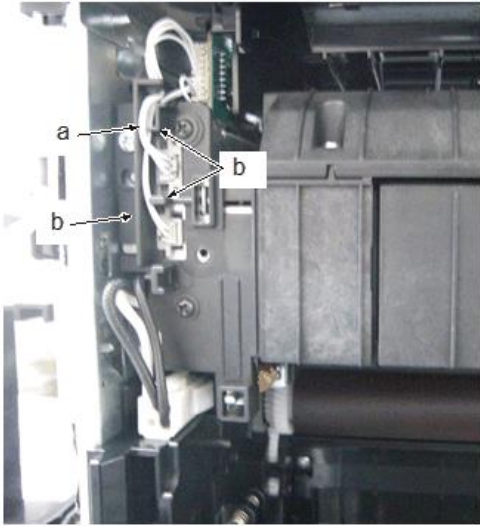

m0cja0097

## Paper Exit Unit

### Paper Exit Unit

1. Remove the upper right cover. ([Upper Right Cover](#))
2. Remove the upper left cover. ([Upper Left Cover](#))
3. Lift up the machine rear side to remove the hook and then remove the upper cover (a).

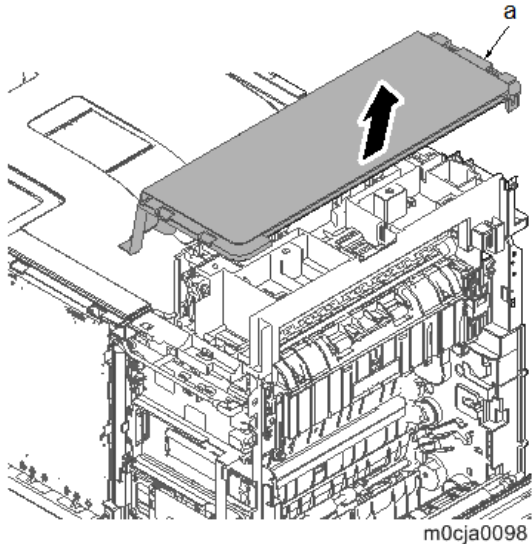

**★ Important**

When reattaching the top cover (a), apply two hooks (c). Press the machine rear side and apply three hooks (b).

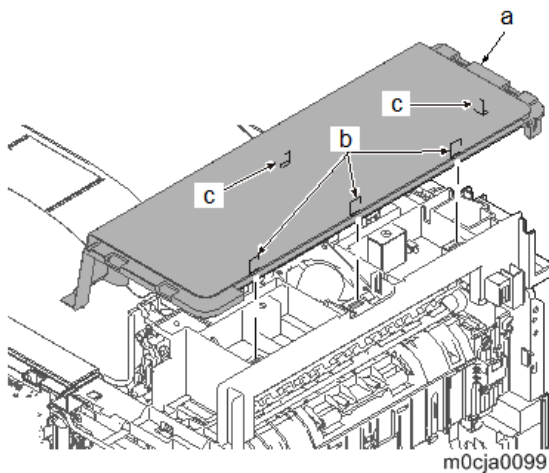

4. Disconnect the FFC (a) from the connector (b) of the main/engine PCB (PCB1) and pull it out from

the opening (c).

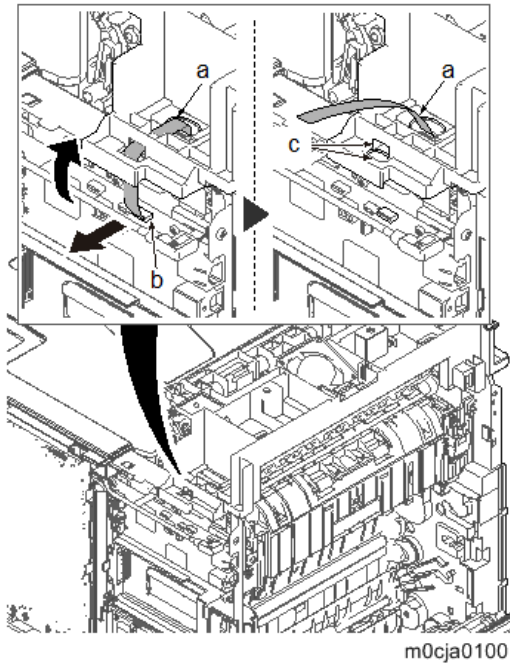

- 5.** Disconnect the connector (a) of the exit fan motor (FAN7) and release the wire (b) from five hooks (c).

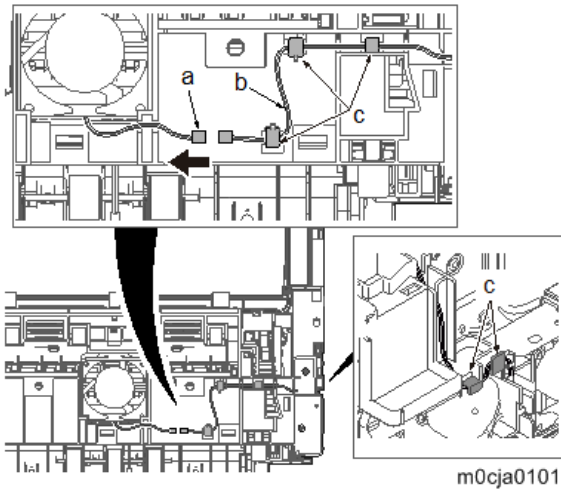

- 6.** Disconnect the connector (a) of the duplex fan motor (FAN2) and release the wire (b) from two

#### 4.Replacement and Adjustment

hooks (c).

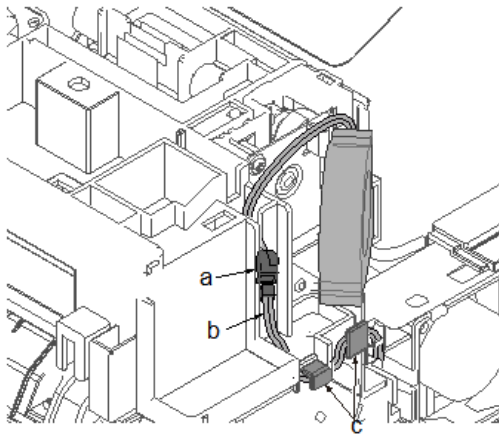

m0cja0102

**7.** Remove four screws (a)(M3x8).

**8.** Lift up the upper stay unit (b), and detach it.

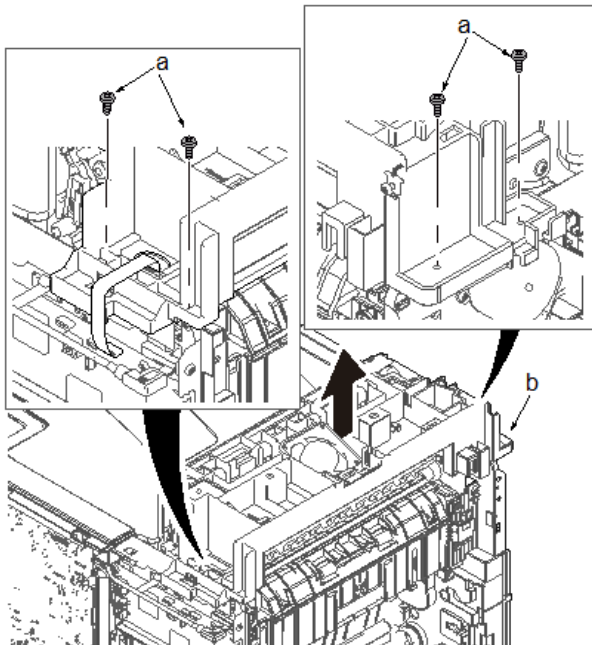

m0cja0103

\*: Secure the screws in the order of the numbers when reattaching it.

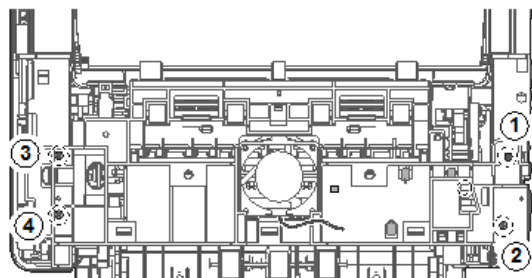

m0cja0104

- 9.** Remove the fusing wire cover [A].

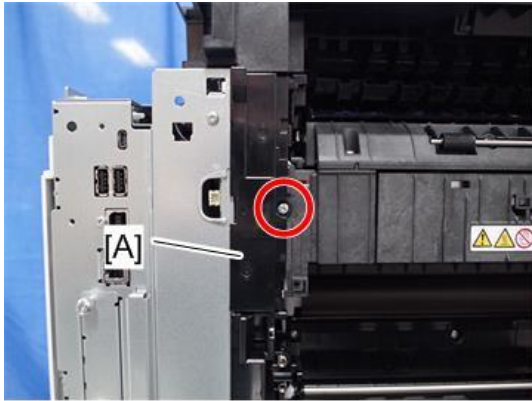

m0cja0212

- 10.** Disconnect the connector (b) of the paper exit PCB (PCB8) (a).

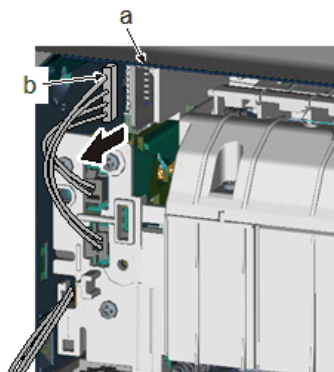

m0cja0105

- 11.** Detach the exit unit (a).

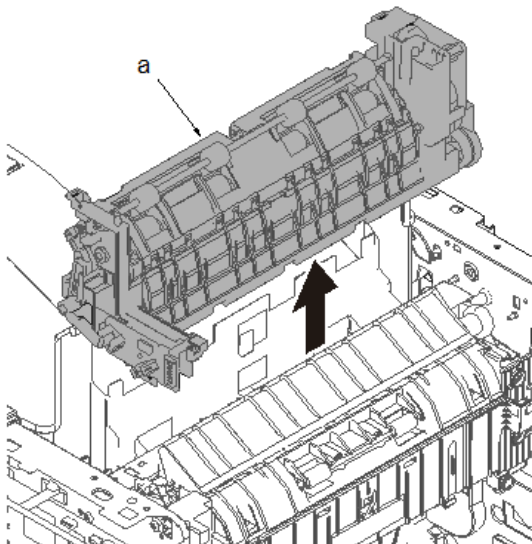

m0cja0106

**★ Important**

When reattaching the exit unit (a), insert the gear shaft (b) into the hole on the side plate and two positioning pins (c) into the holes.

Then, insert the projections (e) into two square holes (d).

4.Replacement and Adjustment

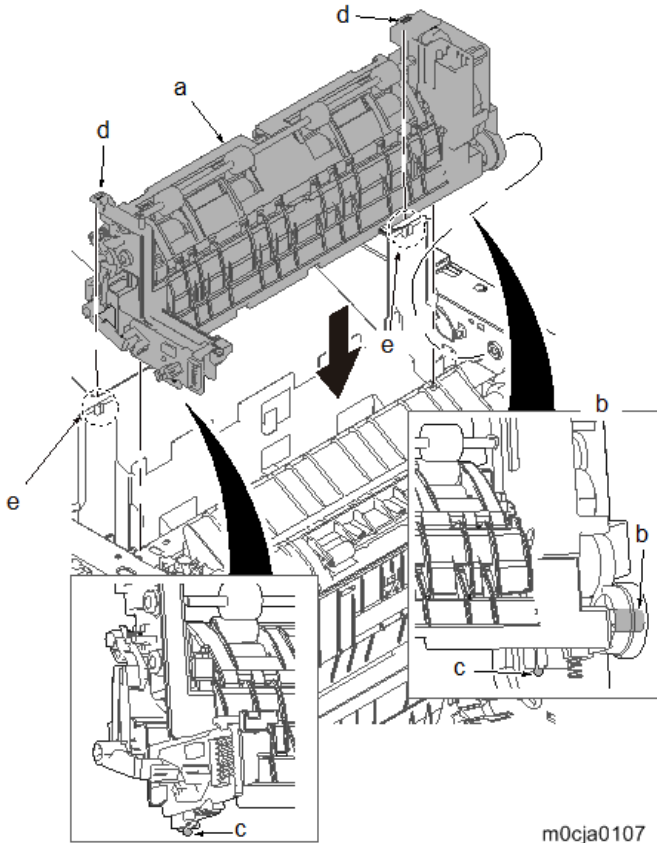

m0cja0107

## Paper Feed Unit

### Paper Conveying Unit

- 1.** Detach the bypass feed roller.
- 2.** Pull the hook (b) toward the machine front side.
- 3.** Slide the bypass paper feed shaft (c).
- 4.** Pull the bypass paper feed shaft (c) out from the drive joint (d).

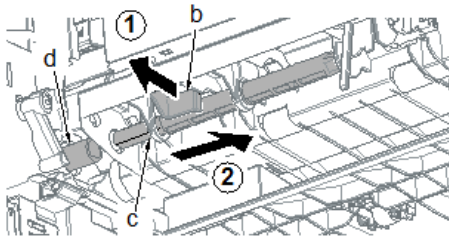

m0cja0108

- 5.** Disconnect the connector (b) (YC6) from the engine relay PCB (PCB21) (a).
- 6.** Release the wire from eight hooks (c).

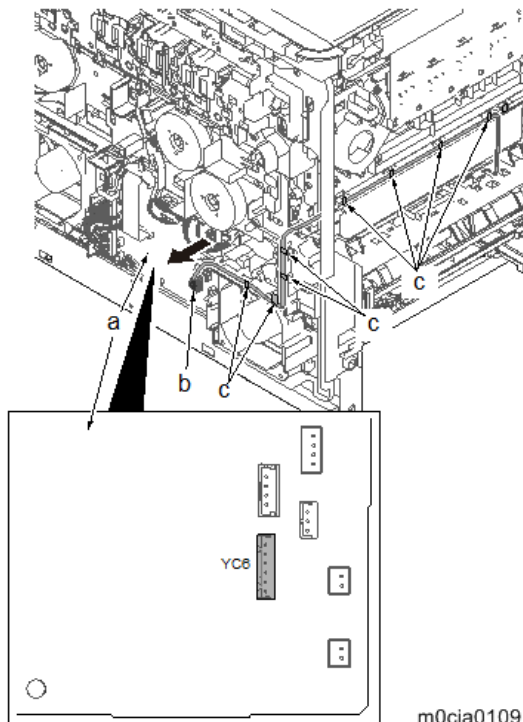

m0cja0109

- 7.** Remove two screws (a)(M3x8).

## 4.Replacement and Adjustment

**8.** Detach the bypass conveying unit (b) by pulling it toward the machine front side.

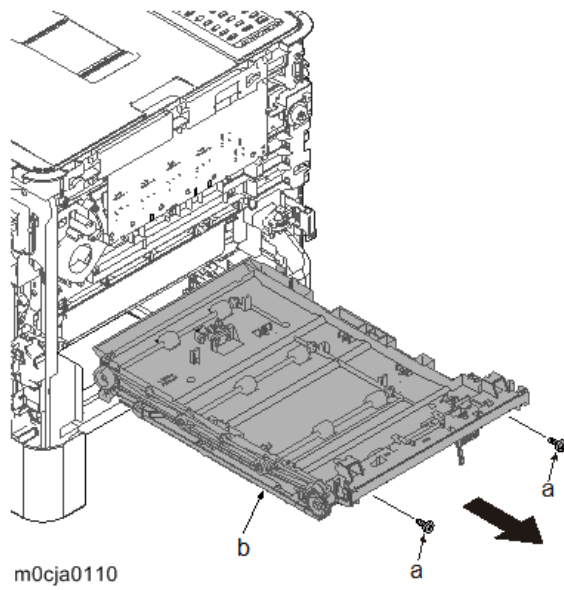

### ★ Important

Check if the wire is fastened to the hook (b) before reattaching the bypass conveying unit (a).

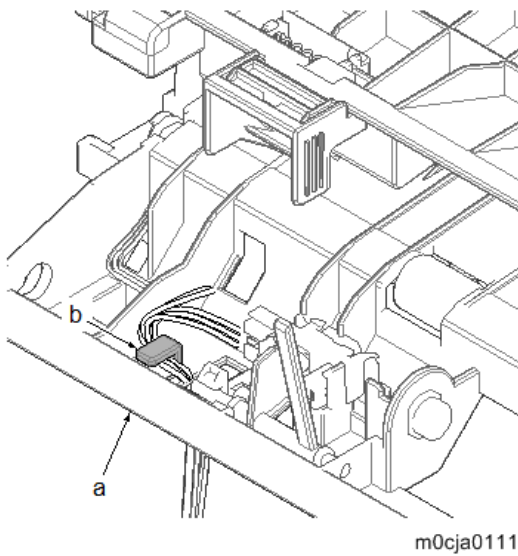

Lower the actuator (a) of the paper sensor before reattaching the bypass conveying unit.

4.Replacement and Adjustment

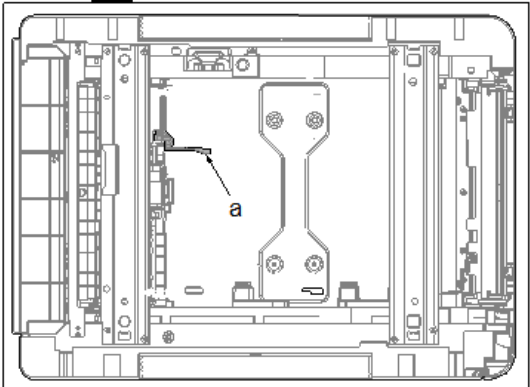
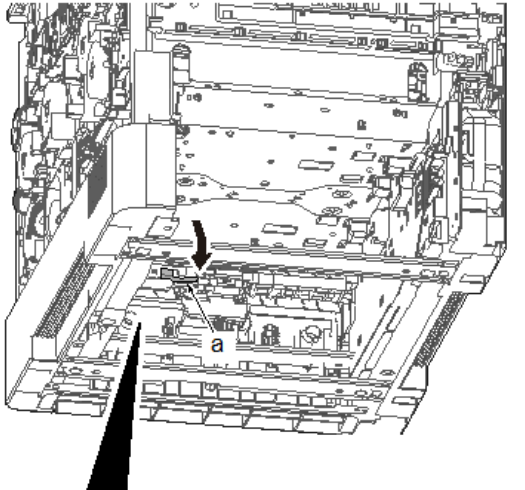

m0cja0112

First apply the positioning (c) to the cutout at the left and right side and then secure the screw.

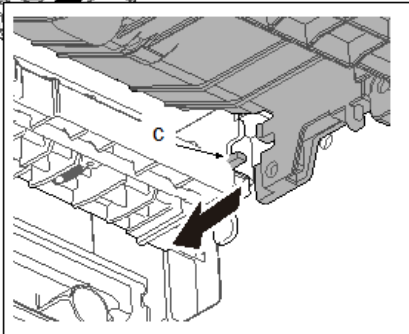
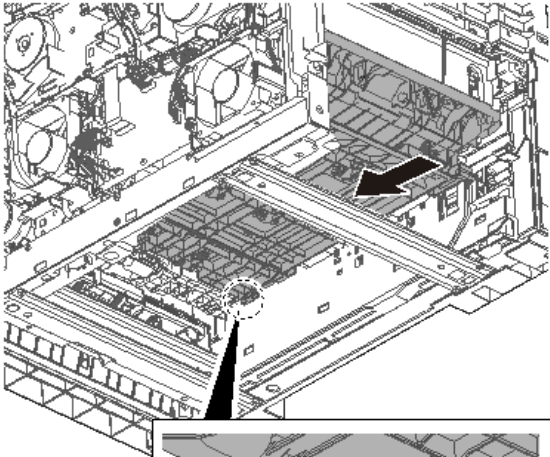

m0cja0113

## 4.Replacement and Adjustment

### Paper Feed Roller and Pickup Roller

- 1.** Remove the retard roller unit. ([Retard Roller](#))
- 2.** Push the machine right side hook (a) outward using a flat-blade screwdriver (b).

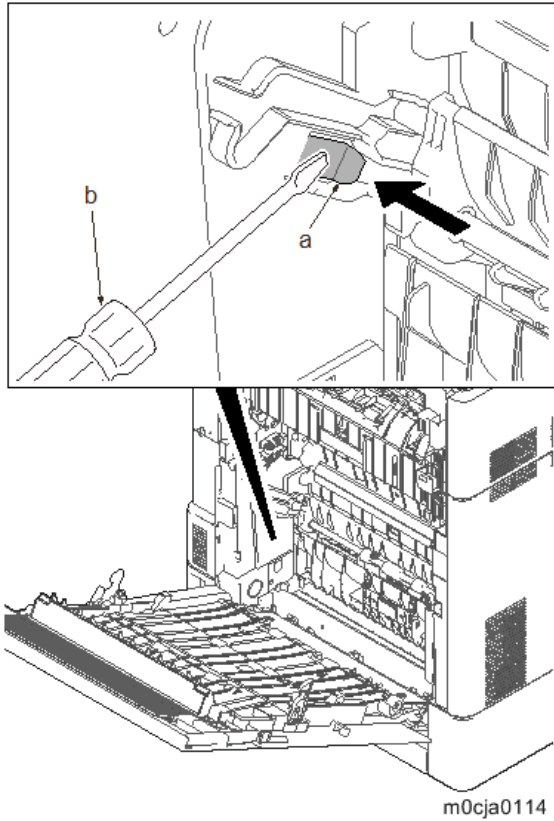

- 3.** Pull the middle roller unit (b) out by holding handle A2 (a).

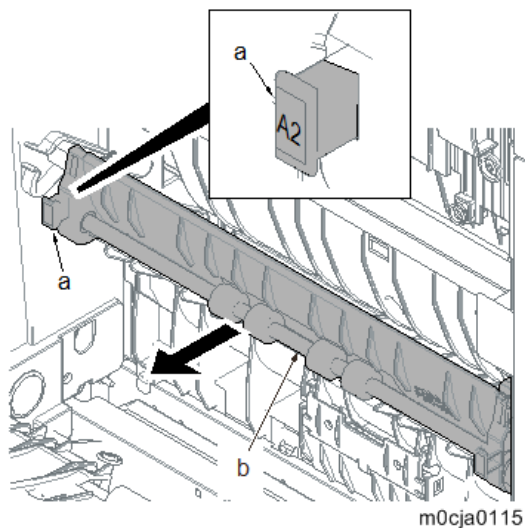

- 4.** Remove the machine right side shaft (b) of the middle roller unit (a) from the rail (c).

- 5.** Detach the middle roller unit (a).

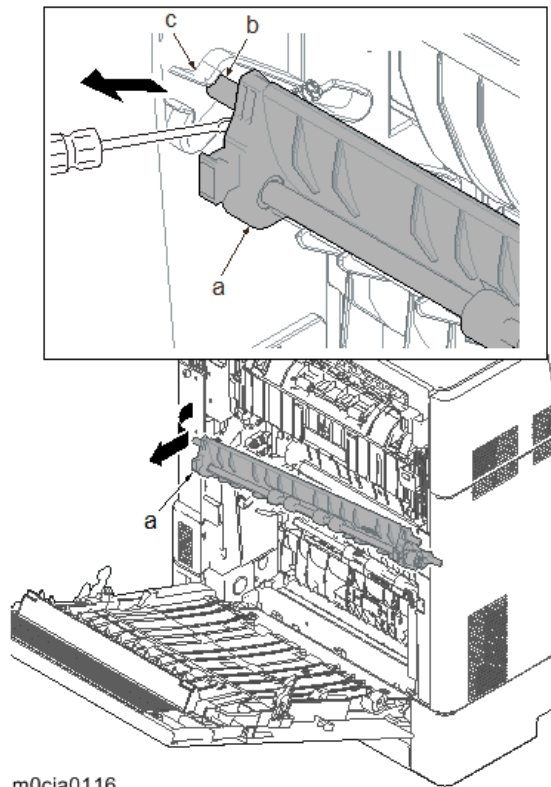

m0cja0116

- 6.** Rotate the lever (b) of the paper feed roller pin (a) toward the machine rear side.

#### 4.Replacement and Adjustment

- 7.** Slide the paper feed roller pin (a) toward the machine right side.

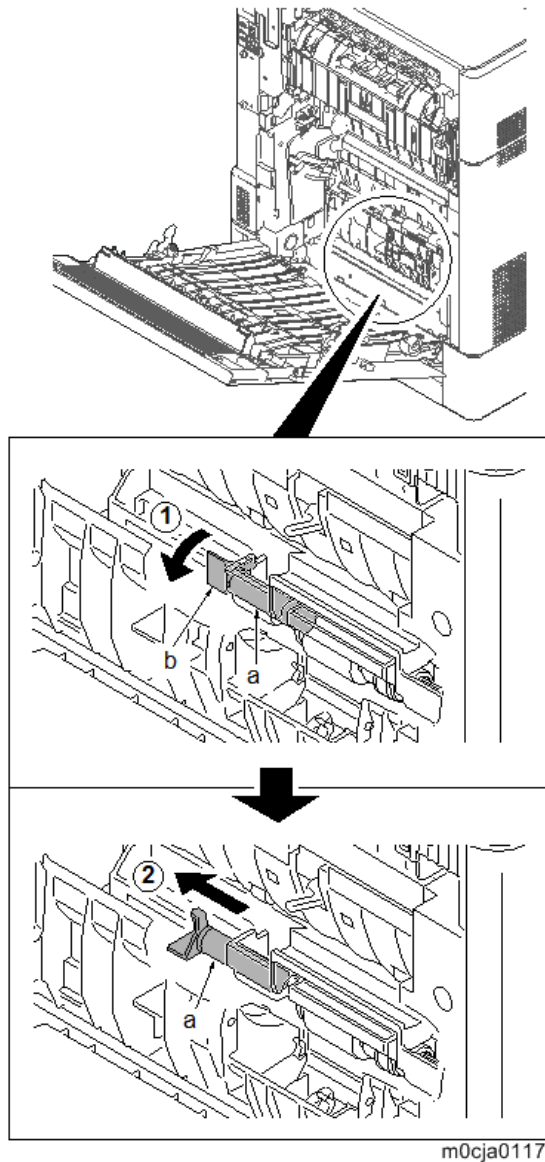

- 8.** Detach the paper feed roller unit (a).  
Make sure it should not come off/be lost when attaching/detaching the paper feed roller unit (a).

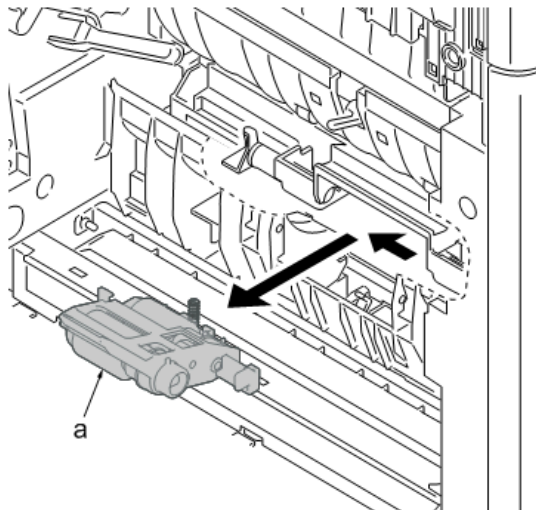

m0cja0118

**9.** Remove the paper feed roller [A] and/or pick-up roller [B].

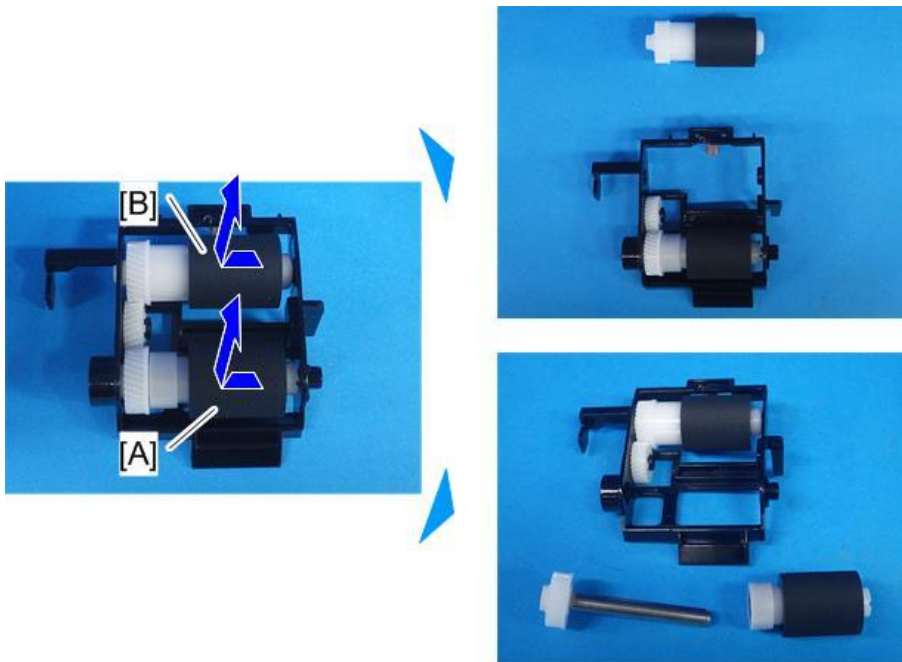

m0cja0261

**★ Important**

When attaching the paper feed roller unit, make sure to check if the pickup spring is attached correctly.

- The way to attach the pickup spring  
 Insert the pickup spring (b) into the cross-shape boss of the feeding holder (a) and press the spring until the edge of the spring contacts on the surface (c) of the paper feeding holder.

#### 4.Replacement and Adjustment

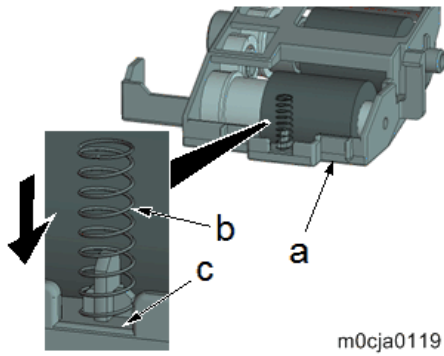

- The way to attach the pickup spring  
After attaching the paper feed roller unit (a), touch your fingertips at the bottom of the pickup roller of it and feel the rebound of the spring if pressing to the upper direction.

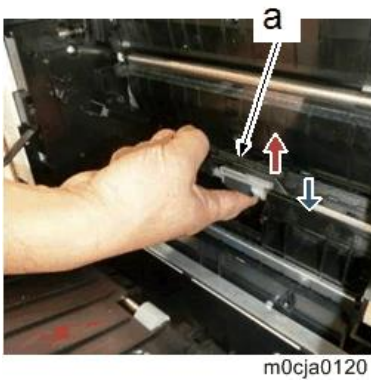

#### ★ Important

After attaching the paper feed roller unit, check the following points to make sure that the paper feed roller unit is properly attached.

- The paper feed roller pin [A] is locked.

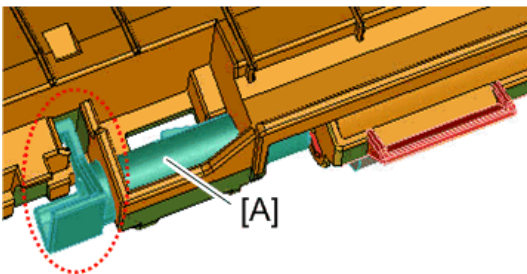

m0cja0243

- When you press the feeding holder [A], it moves up and down smoothly and you can feel the

rebound of the spring.

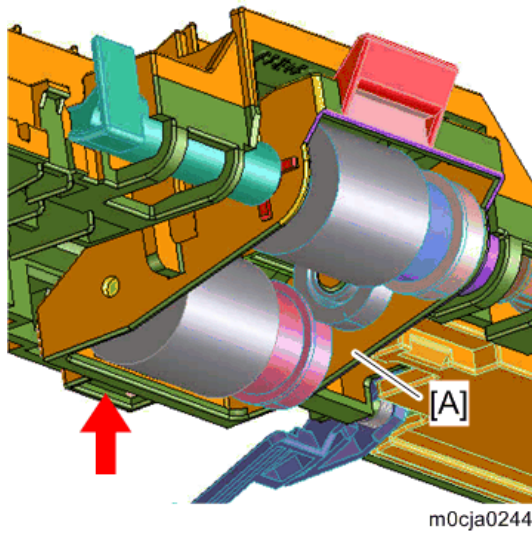

---

## Retard Roller

---

- 1.** Pull out the cassette (a).

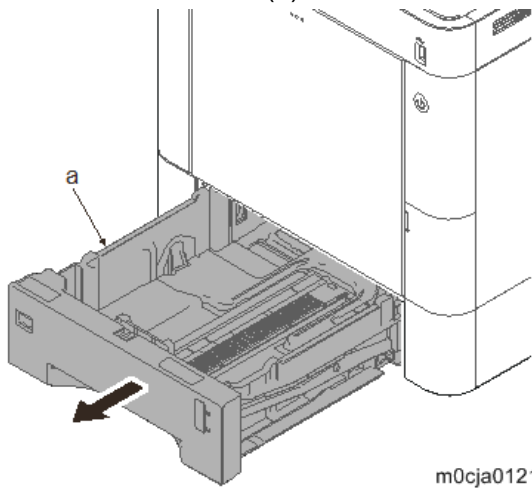

- 2.** Pull the conveying stopper (a) toward the machine right side and rotate it by using a flat-blade screwdriver (b).
- 3.** Release the hook (c) of the conveying stopper (a) from the rib (d) and pull the conveying stopper

## 4.Replacement and Adjustment

(a) out.

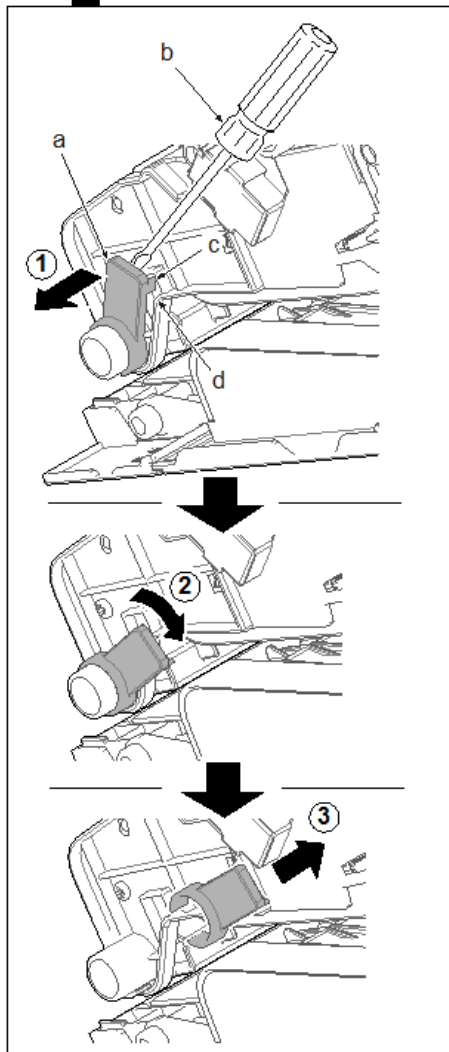
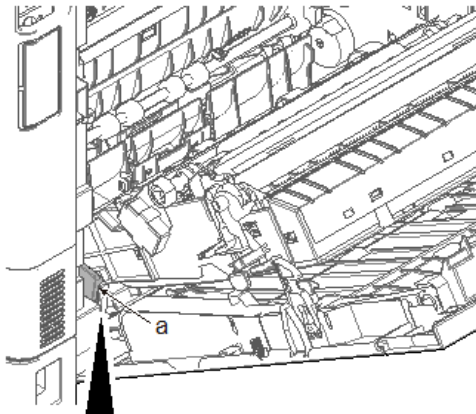

m0cja0122

- 4.** Slide the duplex paper conveying unit (a) toward the machine right side.
- 5.** Release the fulcrum part of the duplex paper conveying unit (a) at the machine left side, and pull

the unit out toward the machine rear side.

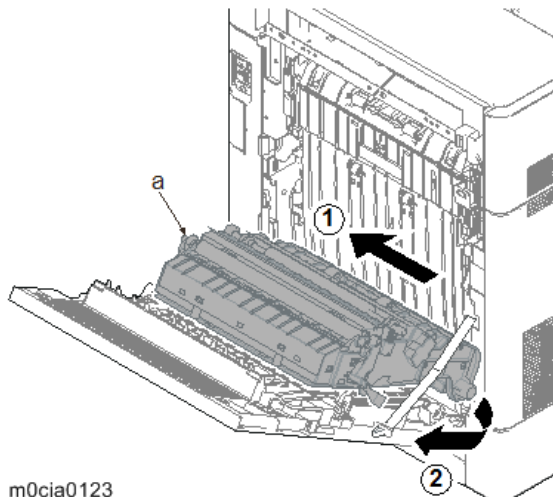

- 6.** Release two hooks (a).
- 7.** Remove the retard cover (b) toward you.  
Place the flat-blade screwdriver (c) into the center and remove it by bending it towards the machine rear side.

#### 4.Replacement and Adjustment

**8.** Remove the retard roller unit (d).

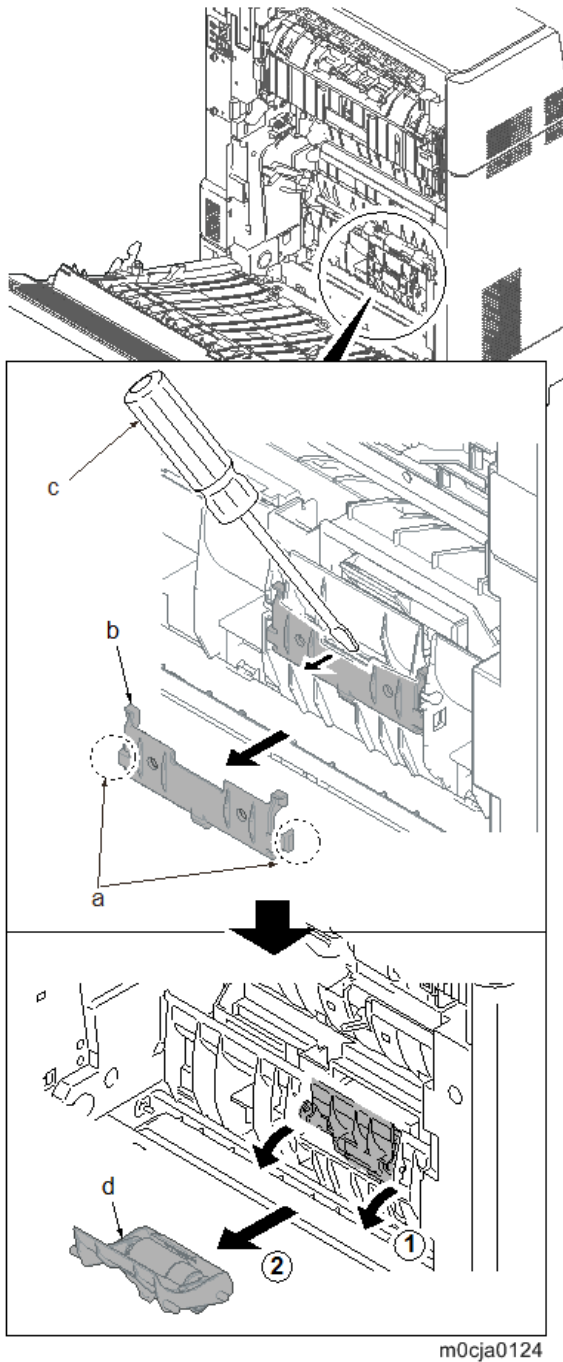

**9.** Remove the retard roller holder [A].

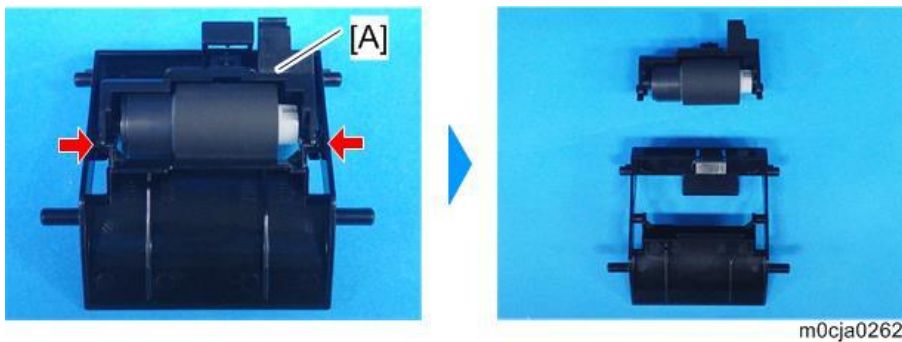

**10.** Remove the retard roller [A].



**★ Important**

- Make sure you install the cassette first when attaching the retard roller unit. The retard pressure release lever must be located at the machine front side from the retard roller unit to apply appropriate pressure.
- To check if the retard roller unit has been installed correctly, remove the cassette and look at the paper feed section.



- If the retard roller unit has been installed correctly: The top of the retard pressure release

#### 4.Replacement and Adjustment

lever [A] is fully seen.

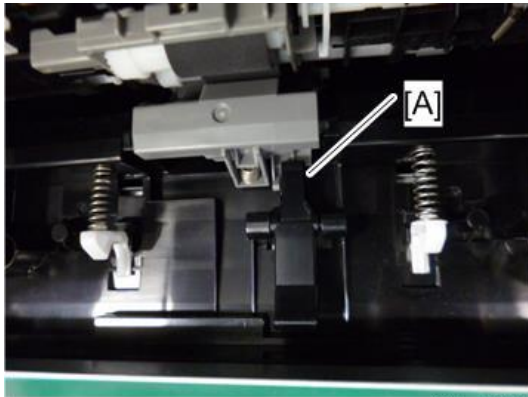

m0cja0265

- If the retard roller unit has not been installed correctly: The top of the retard pressure release lever [A] is hidden behind the gray part.

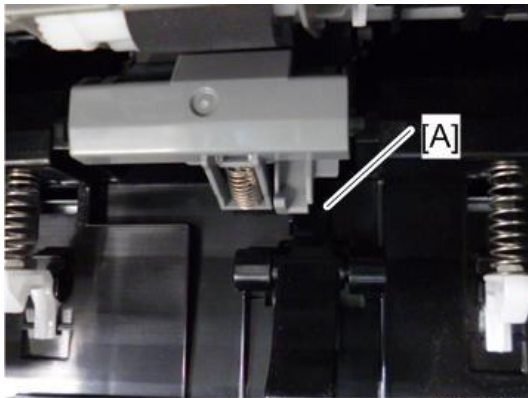

m0cja0266

- When reattaching the retard cover (a), fasten two upper hooks (b) and then push the retard cover to fasten two lower hooks (c).  
Check if four hooks (b and c) are surely fastened after reattaching it.

## 4.Replacement and Adjustment

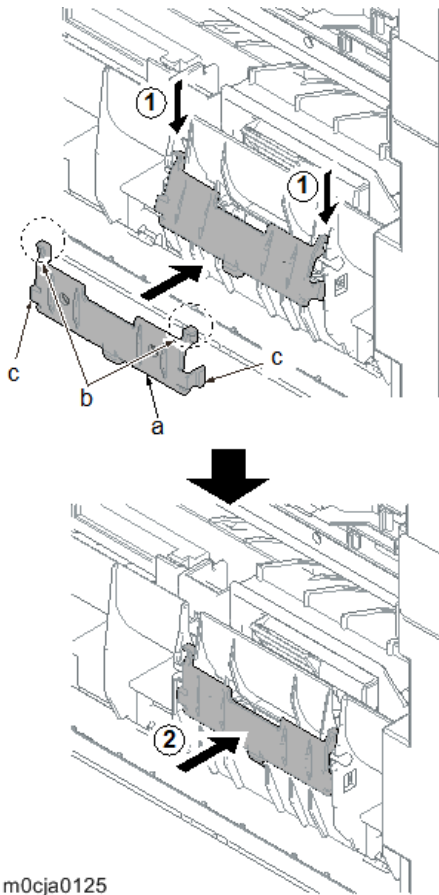

## Bypass Tray Unit

### Bypass Paper Feed Roller

---

- 1.** Pull out the cassette (a).

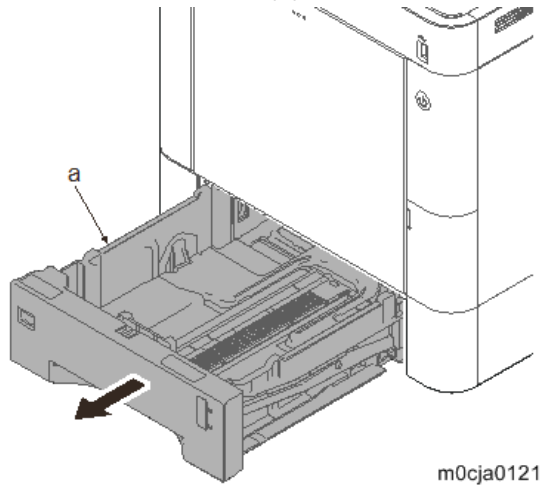

- 2.** Lower the release lever (a).
- 3.** Open the lower bypass paper conveying unit (b).

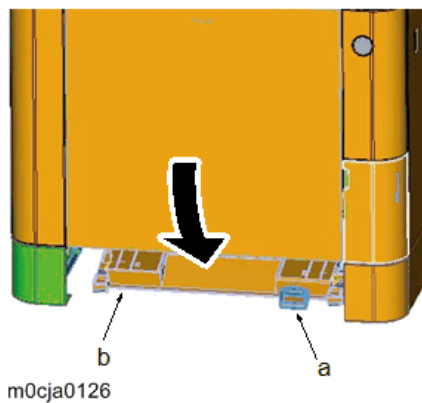

- 4.** Lift the handle [A] and open the top tray [B].

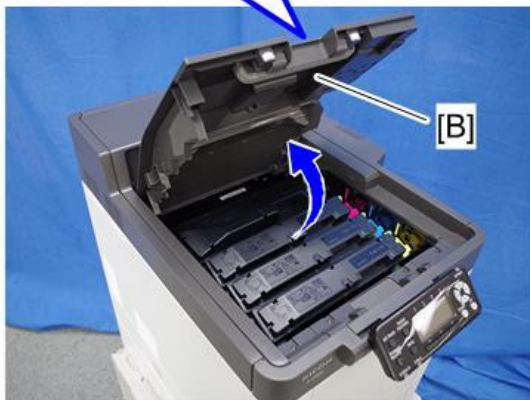

m0cja0050

- 5.** Open the bypass tray (a).  
**6.** Remove two screws (b)(M3x8).  
**7.** Open the waste toner cover (c).

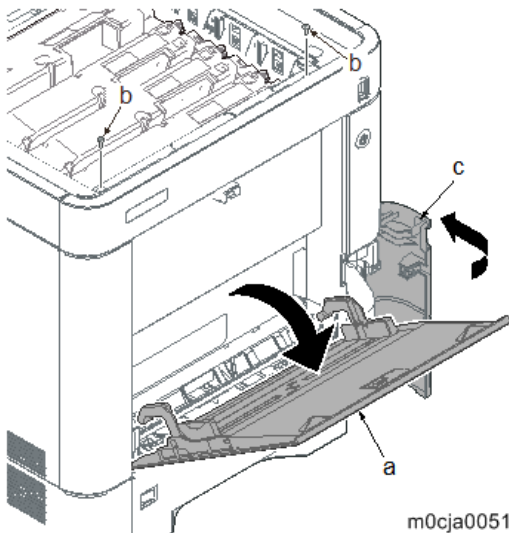

m0cja0051

- 8.** Slightly lift up the front cover (a) to release the boss (b).  
**9.** Tilt the front cover (a) toward the machine front side.

#### 4.Replacement and Adjustment

**10.** Then, remove the front cover (a) by lifting it up.

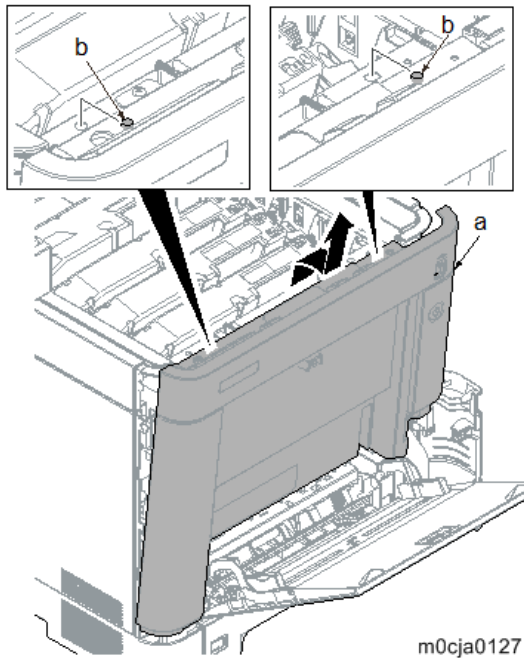

**★ Important**

- Make sure not to touch the waste toner cover sensor (S3) (b) when reattaching the front cover (a). If the waste toner cover sensor (S3) (b) comes off, even if you close the waste toner cover, "cover open" will be displayed.

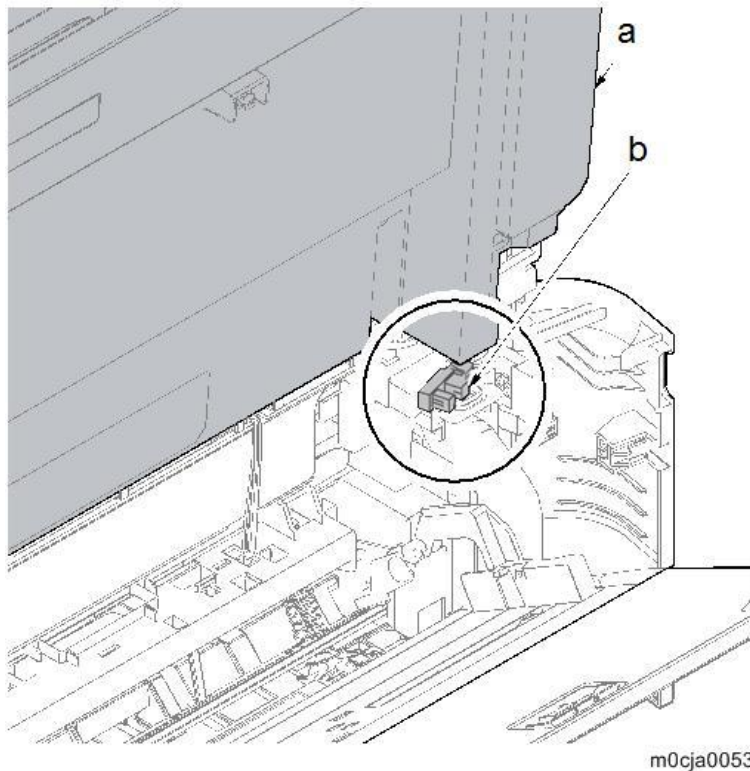

**11.** Open the bypass tray (a) slightly.

- 12.** Lift up the bypass tray cover (b) and release two hooks (c).

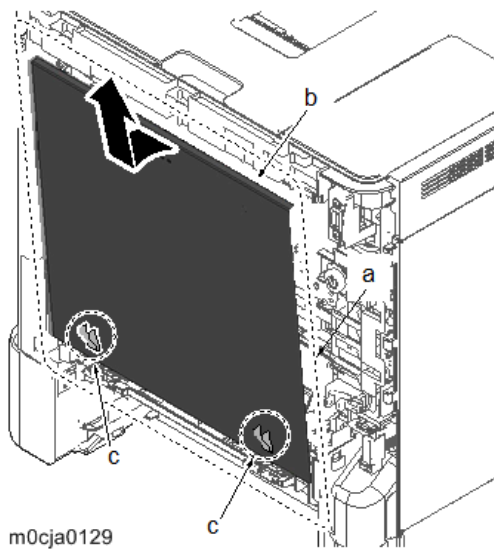

- 13.** Fully open the bypass tray (a).

- 14.** Slide the arm (b) to the machine rear side and lift it up to remove.

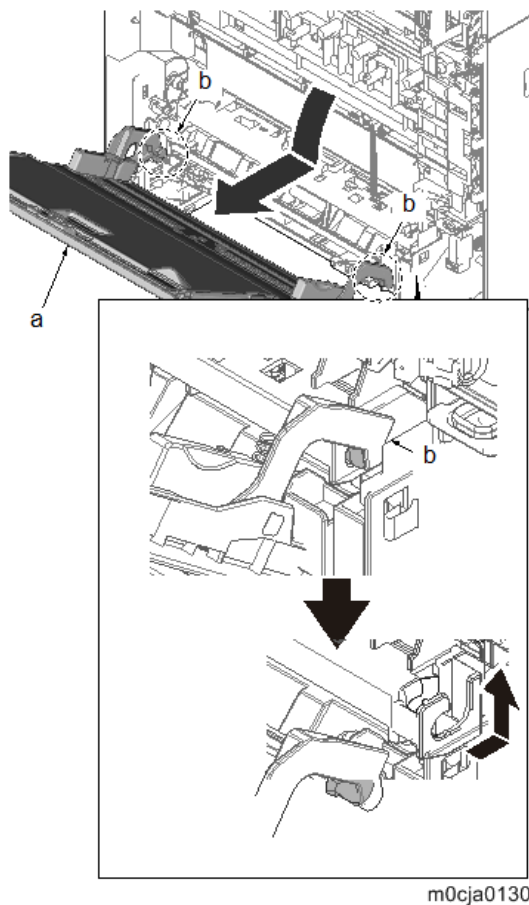

- 15.** Remove two screws (a)(M3x8).

#### 4.Replacement and Adjustment

**16.** Detach the lower bypass paper feed unit (b).

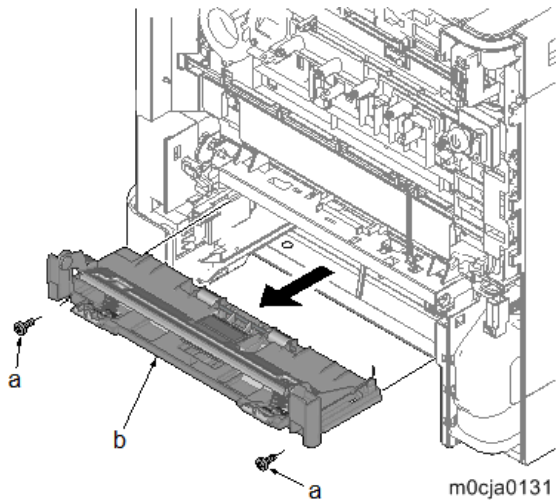

**★ Important**

- Lower the bypass lift plate (b) so that the lever (c) is on it when reattaching the lower bypass paper feed unit (a)

\*: The paper is not fed because the bypass lift plate (b) cannot ascend and descend when it is not in the correct position.

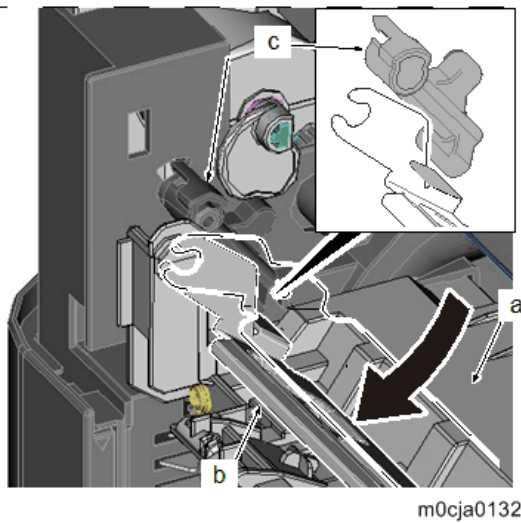

**17.** Pull the hook (a) toward the machine front side.

**18.** Slide the bypass paper feed shaft (b).

**19.** Remove the bypass paper feed roller (c).

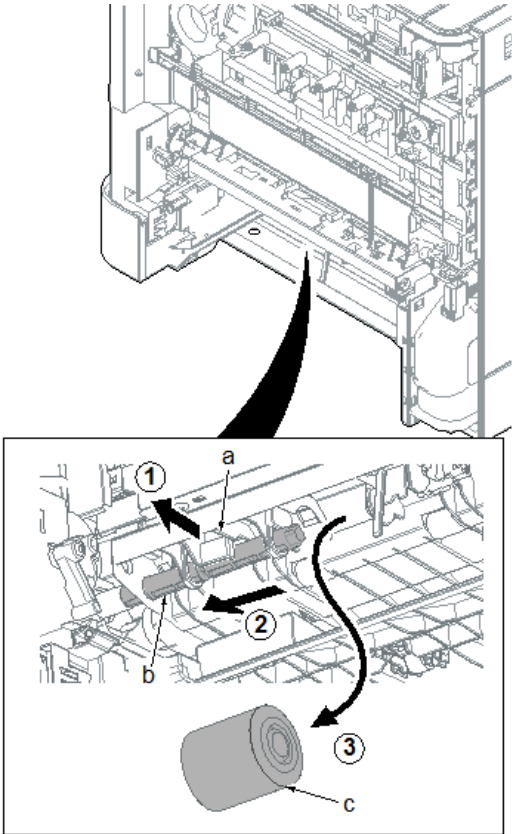

m0cja0133

**Important**

- When reattaching the bypass paper feed roller (c), be aware of the attachment direction.

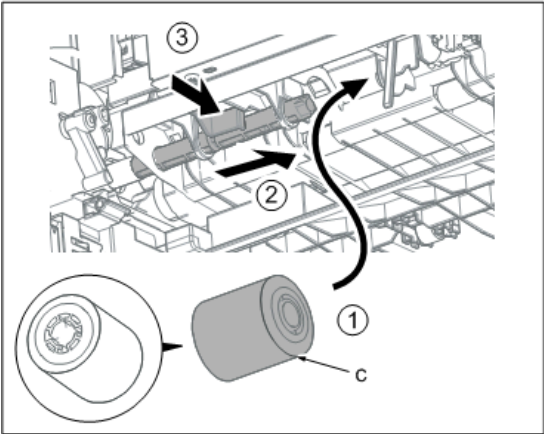

m0cja0134

## Drive Unit

### Main Drive Motor Unit

1. Remove the lower left cover. ([Lower Left Cover](#))

View of the main drive unit (a)

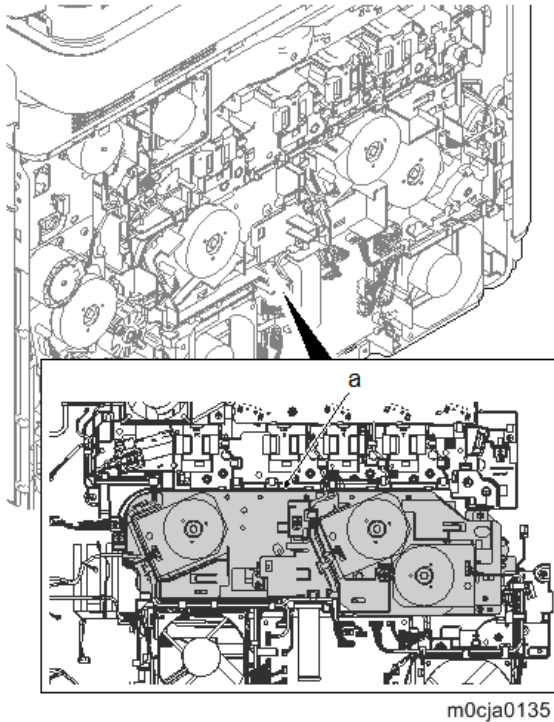

2. Disconnect the connector (b) of the drum motor 1 (M7) (a). Release the wire from seven hooks (c).

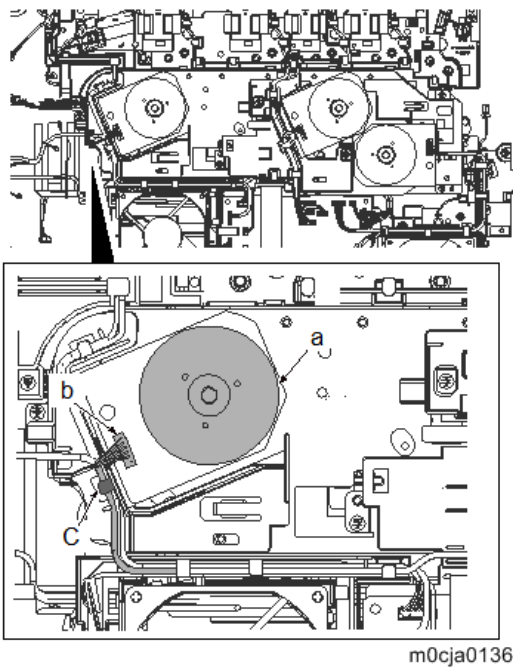

3. Disconnect three connectors (b) from the engine relay PCB (PCB21) (a). Release the wire (c) from

eight hooks (d).

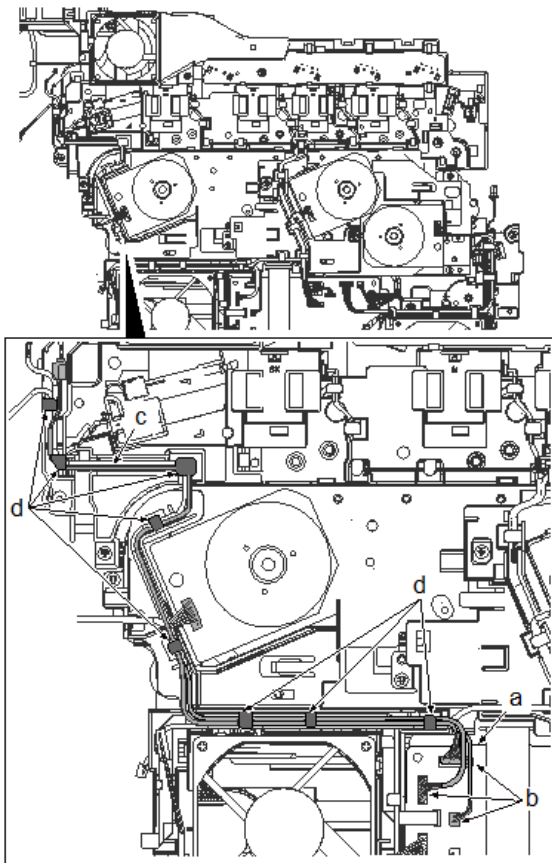

m0cja0137

- 4.** Disconnect the connector (b) of the drum motor 2 (M8) (a).
- 5.** Release the wire from two hooks (f) of the wire guide (e).
- 6.** Disconnect the connector (d) of the developer motor (M5) (c).

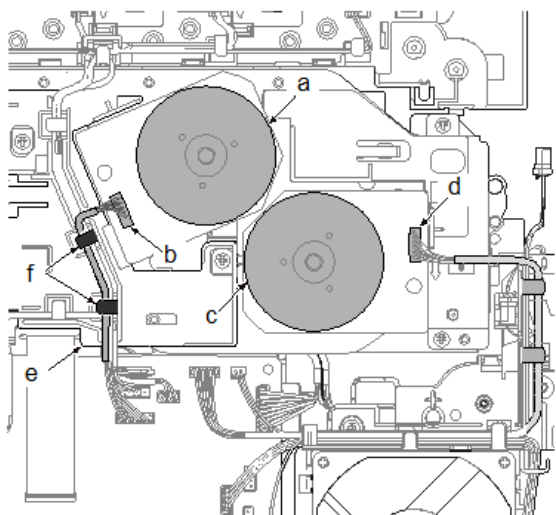

m0cja0138

- 7.** Disconnect two connectors from the engine relay PCB (PCB21) (a).

#### 4.Replacement and Adjustment

- 8.** Release the wire from four hooks (c) of the wire guide (b).

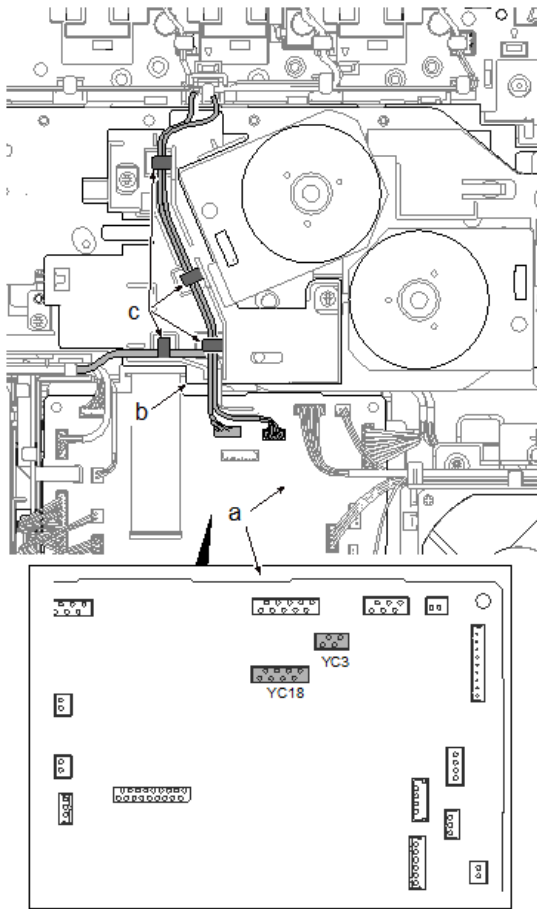

m0cja0139

- 9.** Lift the handle [A] and open the top tray [B].

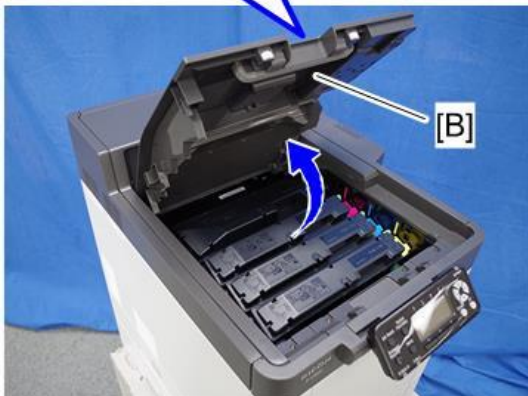

m0cja0050

**10.** Detach toner cartridge Y (a).

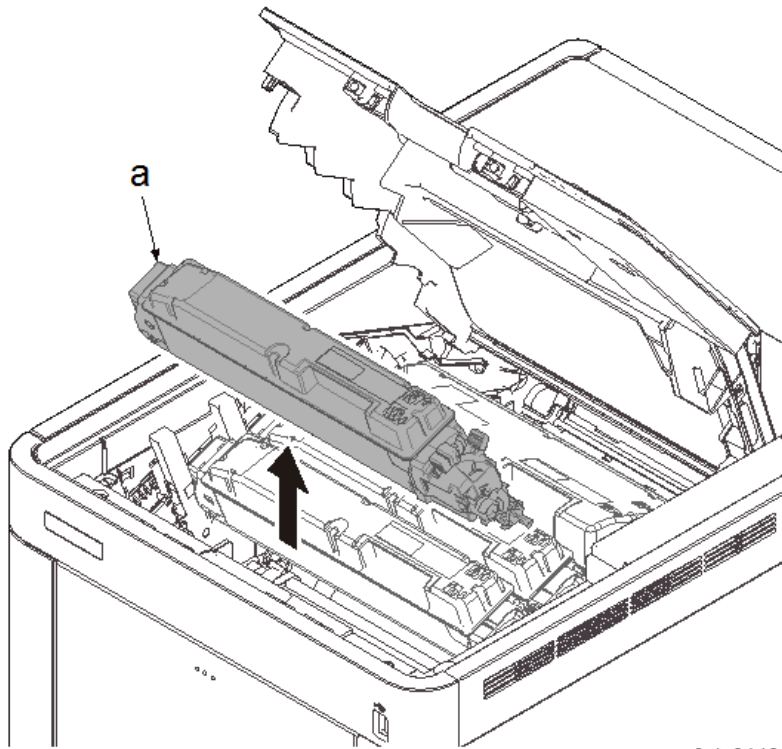

m0cja0140

**11.** Remove the screw (a)(M3x12).

**12.** Remove the lever cover (b).

**13.** Lift up the drive release lever (c).

\*: When raising the lever, the joint of the drive coupling is released.

**★ Important**

- If omitting to attach the lever cover, "Cover open" message is displayed while the exit tray switch (SW2) is not turned on.

#### 4.Replacement and Adjustment

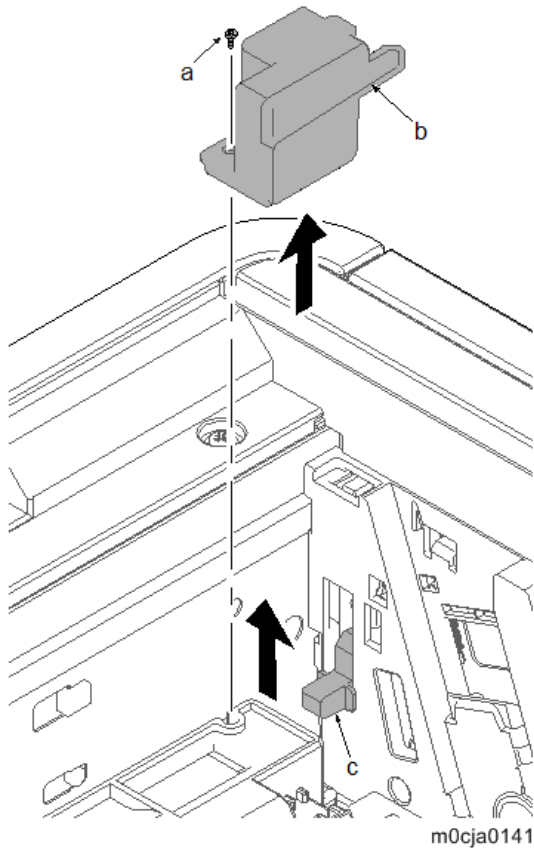

- 14.** Remove six screws (a)(M3x8).
- 15.** Detach the main drive motor unit (b).

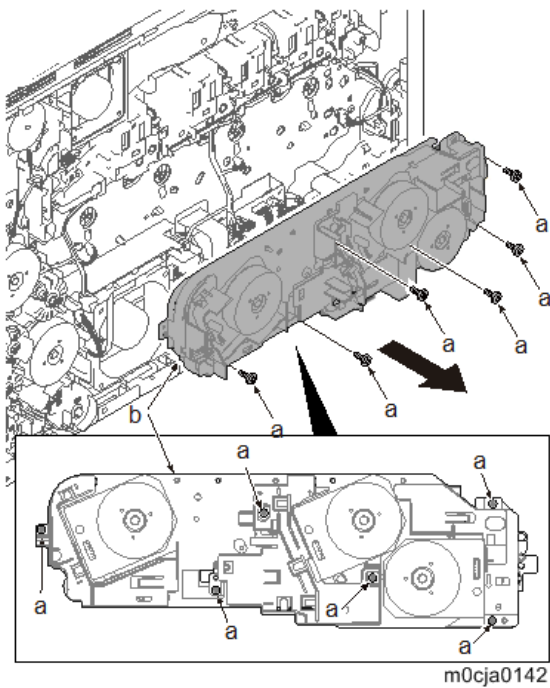

\*: When detaching the main drive motor unit (a), pull out the drive release lever (b) from the drive release joint (c).

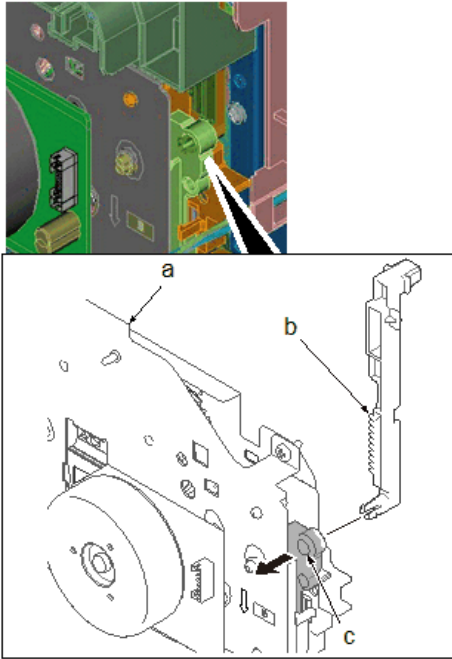

m0cja0143

**16.** Check the main drive motor unit and clean or replace it if necessary.

**17.** Reattach the parts in the original position.

**★ Important**

- After reattaching the main drive motor unit (a), check if the couplings for driving the ITB unit, the developer unit and the drum unit are relocated by being connected with the drive release lever (b).

**★ Important**

- Attach the main drive motor unit (a) after confirming the drive coupling is at the release position.  
(Drive release joint (b) is raised.)

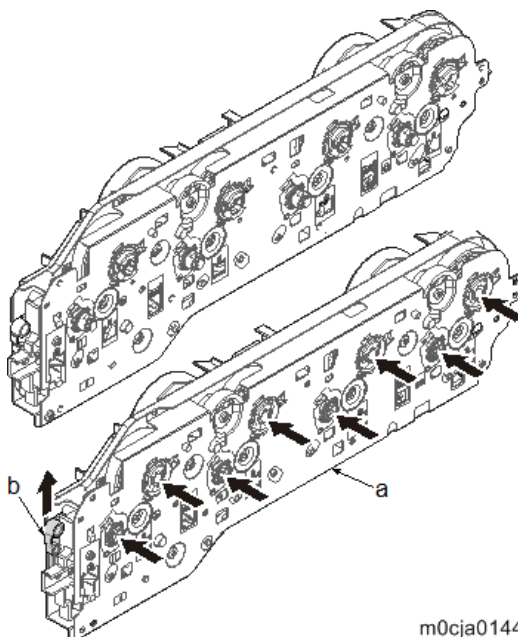

m0cja0144

## 4.Replacement and Adjustment

- Insert the drive release lever (b) into the drive release joint (c) when reattaching the main drive motor unit (a)

Do not turn the developer motor (M5) (d) in the reverse direction of the engraving arrow (e).

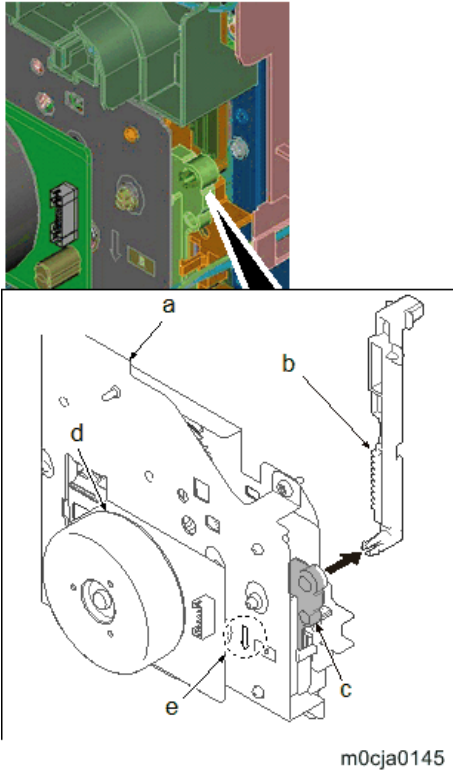

---

## Conveying Drive Unit

---

1. Remove the lower left cover. ([Lower Left Cover](#))
2. Disconnect the connector (b) of the image transfer motor (M6) (a).

- 3.** Release the wire from four hooks (c).

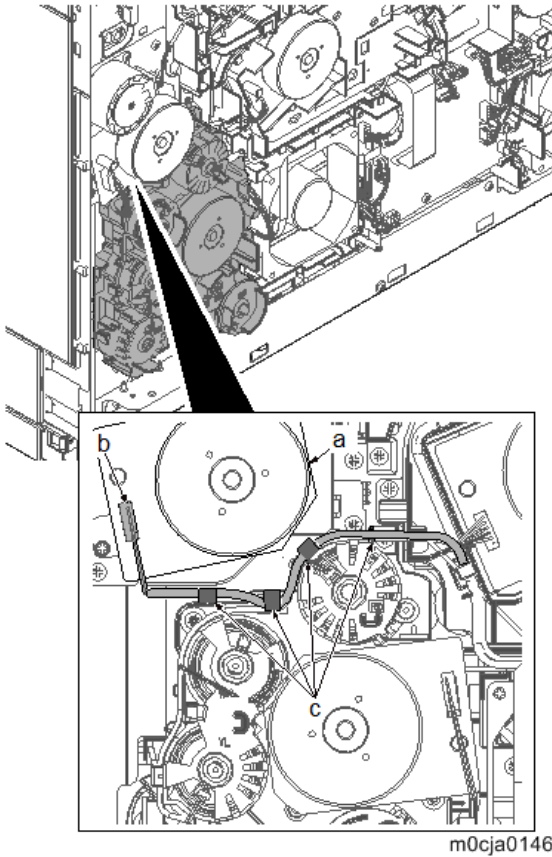

- 4.** Disconnect six connectors (b) and (e) of the clutch in the conveying drive unit (a).  
**5.** Disconnect the connector (c) of the motor in the conveying drive unit.  
**6.** Release the wire from six hooks (d).

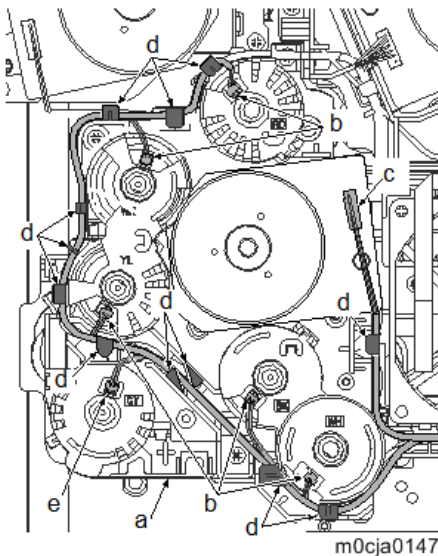

- 7.** Remove three screws (a)(M3x12).  
**8.** Detach the conveying drive unit (b).  
**9.** Check the conveying drive unit and clean or replace it if necessary.

## 4.Replacement and Adjustment

**10.** Reattach the parts in the original position.

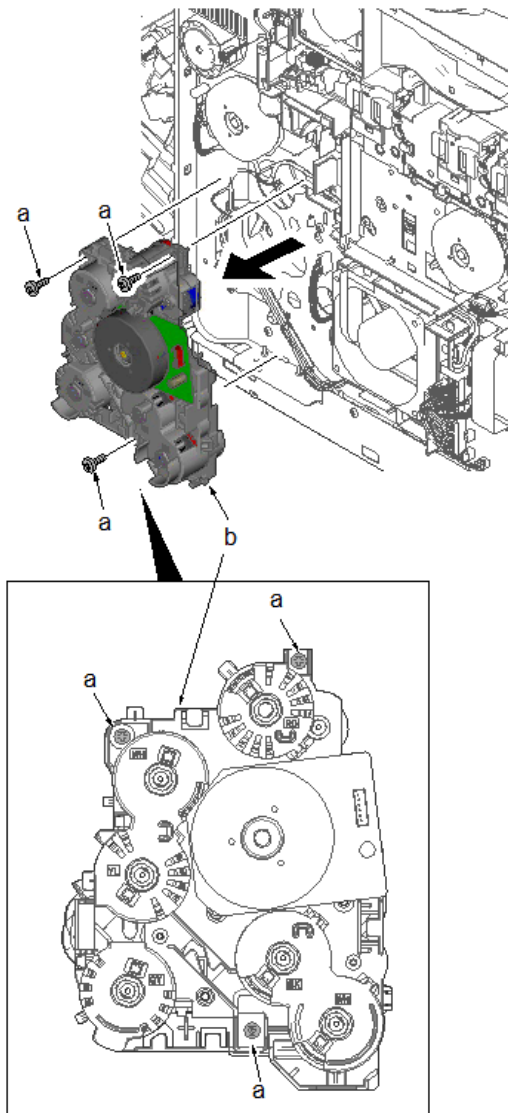

m0cja0148

---

### Paper Feed Drive Unit

---

- 1.** Remove the lower left cover. ([Lower Left Cover](#))
- 2.** Remove the front cover. ([Front Cover](#))
- 3.** Remove the bypass tray. ([Bypass Paper Feed Roller](#))

- 4.** Rotate the cam (a) inside the main unit to the position in the figure.

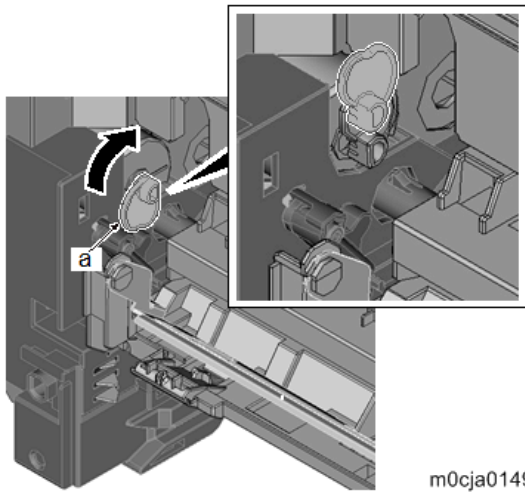

m0cja0149

- 5.** Disconnect eight connectors (b) from the engine relay PCB (PCB21) (a).

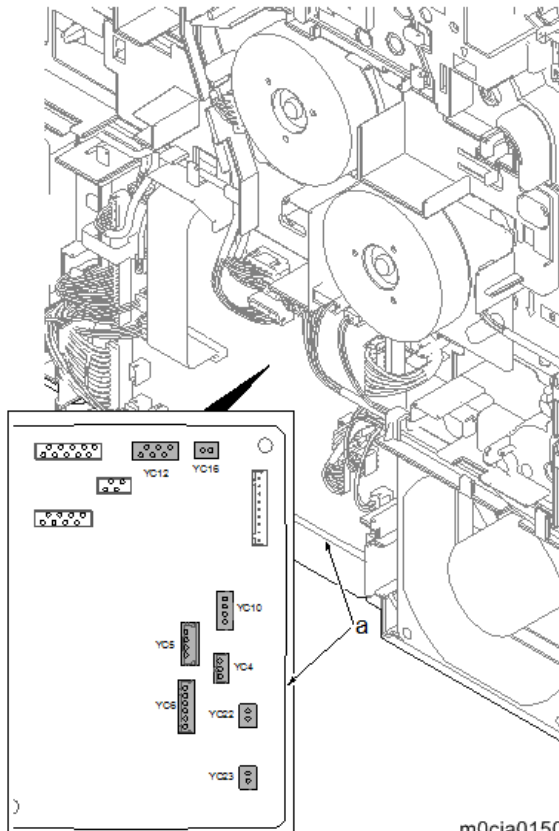

m0cja0150

## 4.Replacement and Adjustment

- 6.** Release the wire (b) from five hooks (a).

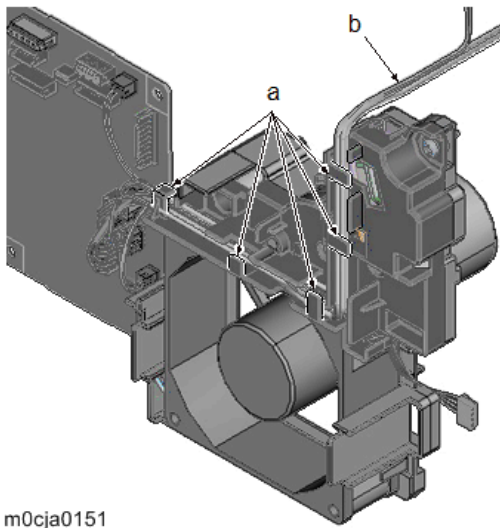

- 7.** Remove two screws (a)(M3x12).
- 8.** Lift up the bypass paper feed drive unit (b) to release the lower two hooks (c).
- 9.** Detach the bypass paper feed drive unit (b).
- 10.** Check the bypass paper feed drive unit and clean or replace it if necessary.
- 11.** Reattach the parts in the original position.

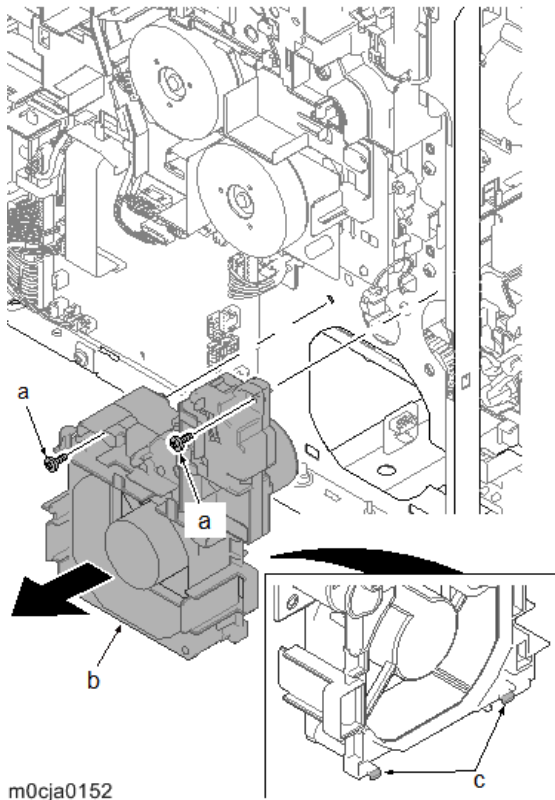

---

## Toner Motor Unit

---

- 1.** Remove the lower left cover. ([Lower Left Cover](#))

## 4.Replacement and Adjustment

- 2.** Remove the main drive motor unit (a). ([Main Drive Motor Unit](#))
- 3.** Disconnect the connector (b) of the exit tray switch (SW2) (a).
- 4.** Release the wires of the duplex exit motor (M3) (d) and the fusing motor (M2) (e) from three hooks (c).
- 5.** Disconnect the connector (g) of the cartridge fan motor (FAN3) (f).

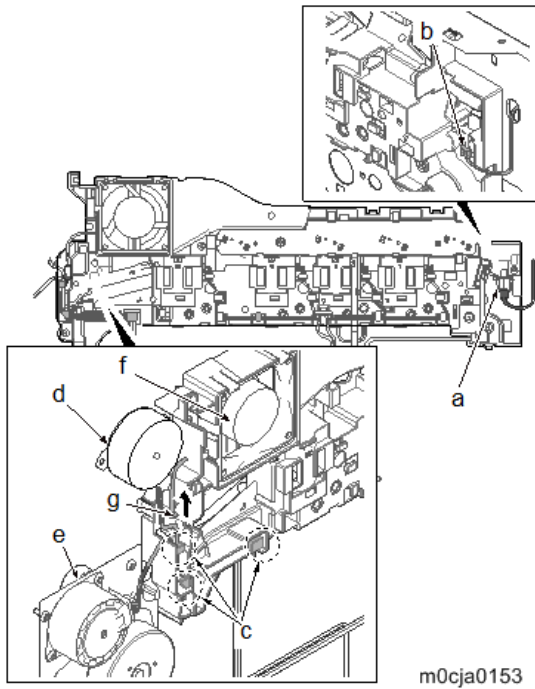

- 6.** Release the wire from three hooks (b) of the toner motor unit (a).

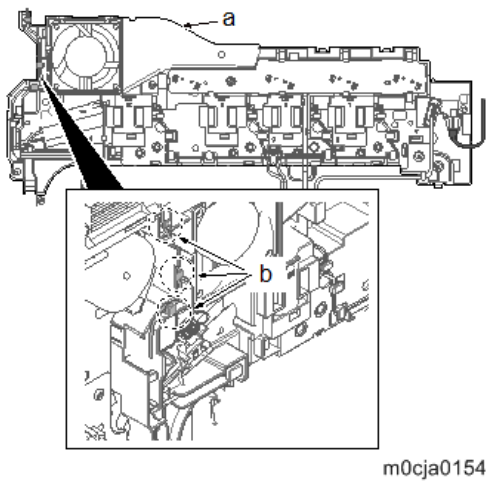

#### 4.Replacement and Adjustment

- 7.** Release the hook of the cleaner spring (a).

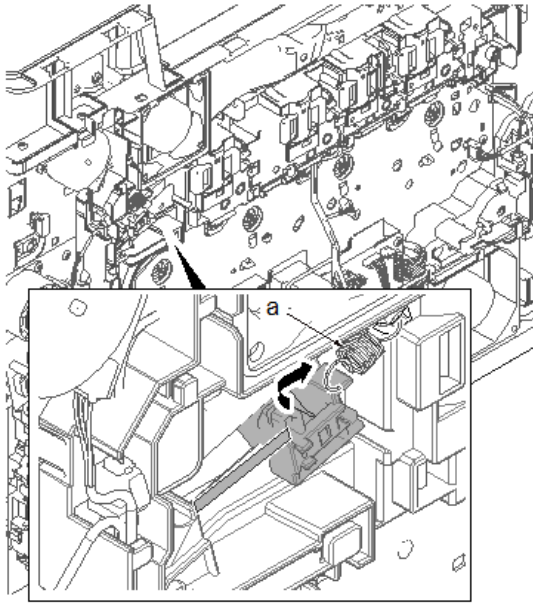

m0cja0155

- 8.** Relocate the cleaner slider (a) to the center of the rail (b).  
**9.** Insert a flat-blade screwdriver (c) from the square hole.  
**10.** Lift up the hook (d) to release. Remove the cleaner slider (e) while rotating it.

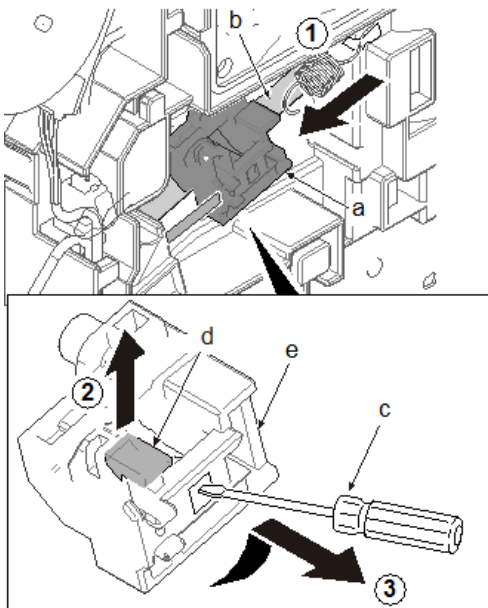

m0cja0156

- 11.** Remove the cleaner film (b) through the gap of the ribs (a).

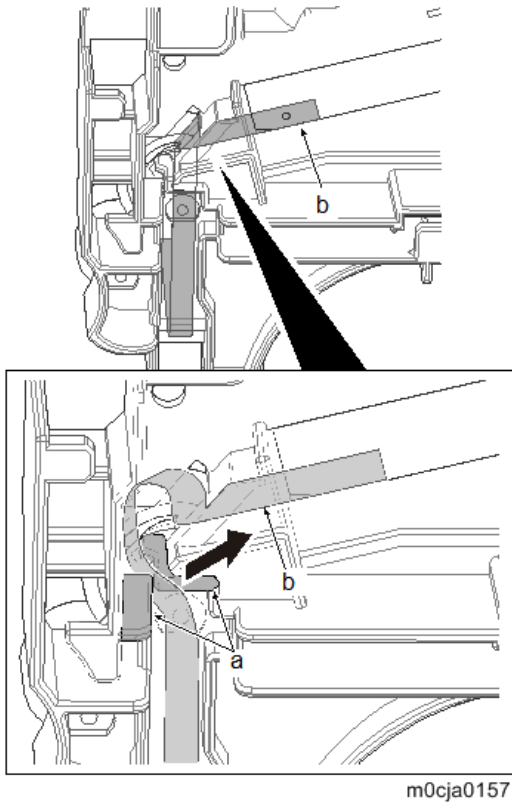

- 12.** Remove four screws (b)(M3x8) from the toner motor unit (a).

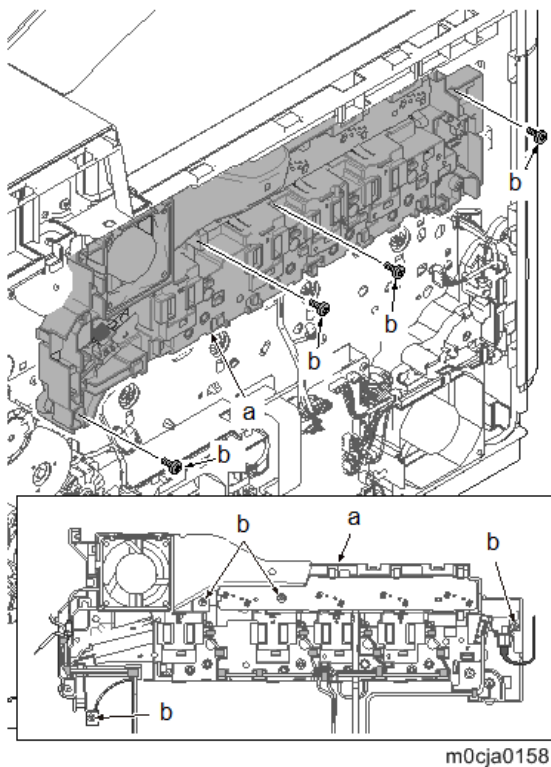

- 13.** Release eight hooks (a).

- 14.** Detach the toner motor unit (b).

\*: Check the triangle engravings (c) as for the position of the three inside hooks.

## 4.Replacement and Adjustment

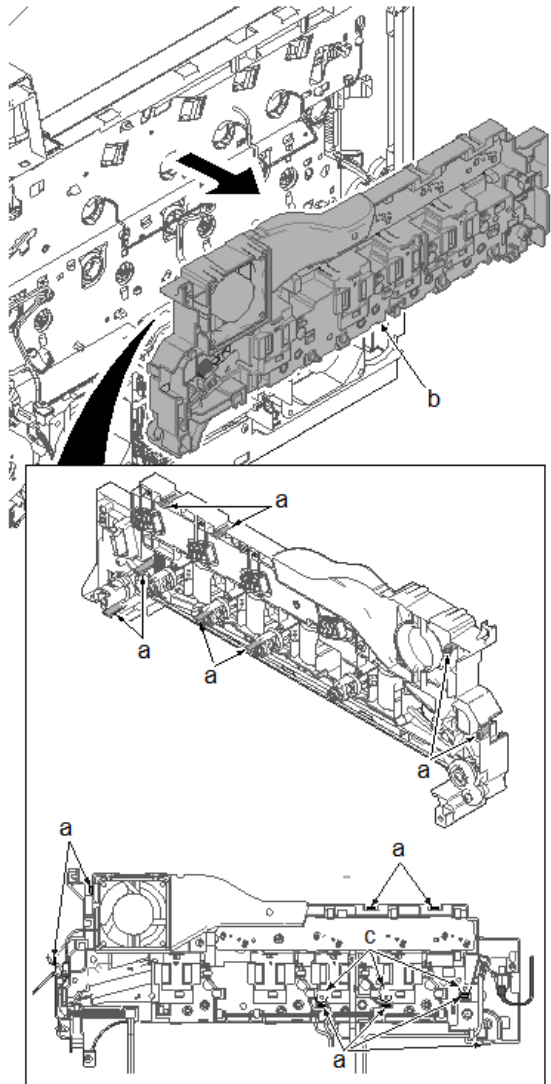

m0cja0159

---

### Toner Motor (M11)

---

- 1.** Remove the tension spring (a).

\*: Take care not to lose the spring.

## 4.Replacement and Adjustment

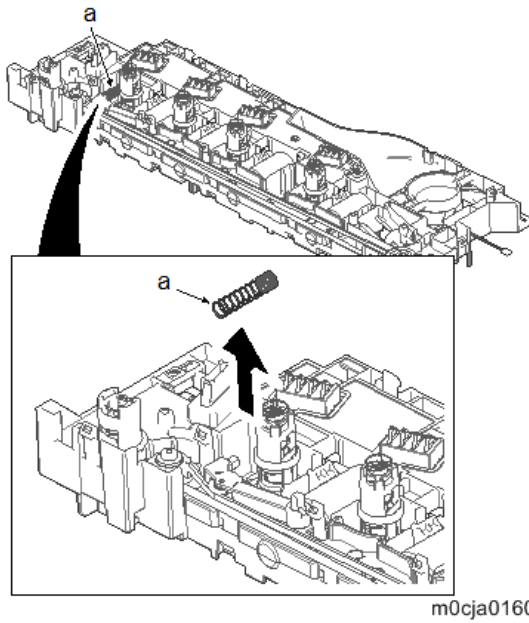

- 2.** Release the tension arm (a) to loosen the tension.
- 3.** Remove the belt (b).

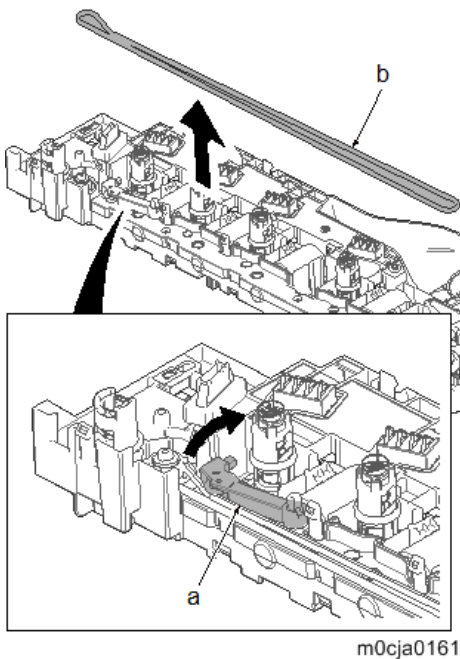

- 4.** Release six hooks (a).

#### 4.Replacement and Adjustment

- 5.** Remove the toner motor cover (b).

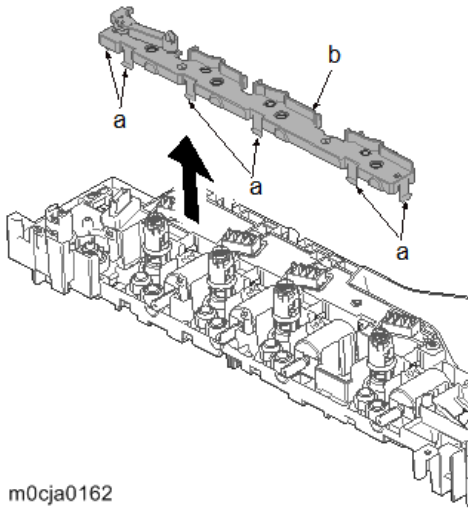

- 6.** Disconnect the connector (a) of each toner motor (M11).

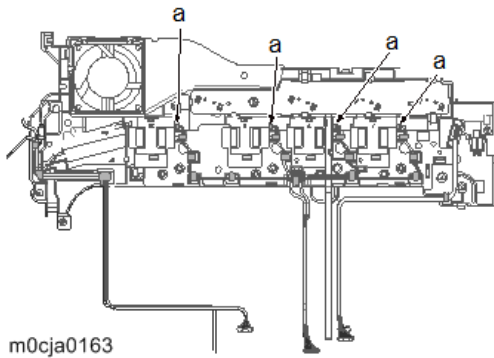

- 7.** Release each set of two hooks (a).

- 8.** Remove four toner motors (M11) (b).

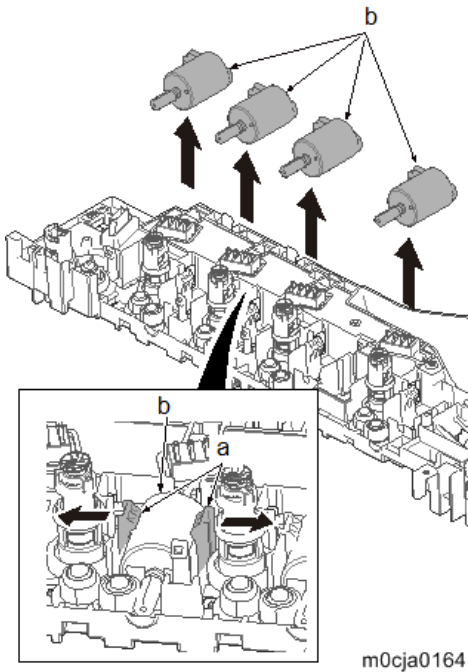

**★ Important**

- Apply one drop of grease (d) (VSSG9005: MOLYKOTE EM-50L) on the gear surface

## 4.Replacement and Adjustment

when attaching the new motor.

Insert the boss (c) to the positioning hole (b) of the toner motor (M11) (a) and reattach it.

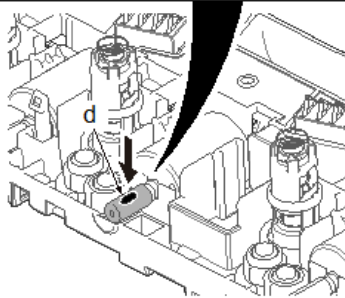
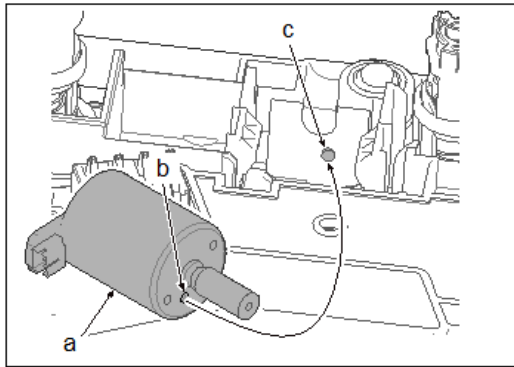

m0cja0165

- Reattach the drive cam (b) if coming off when reattaching the toner motor unit (a). Check if the drive cam (b) gear is meshed with the lock lever (c) gear when reattaching the toner motor unit (a).

\*: Drive can not be released without the drive cam.

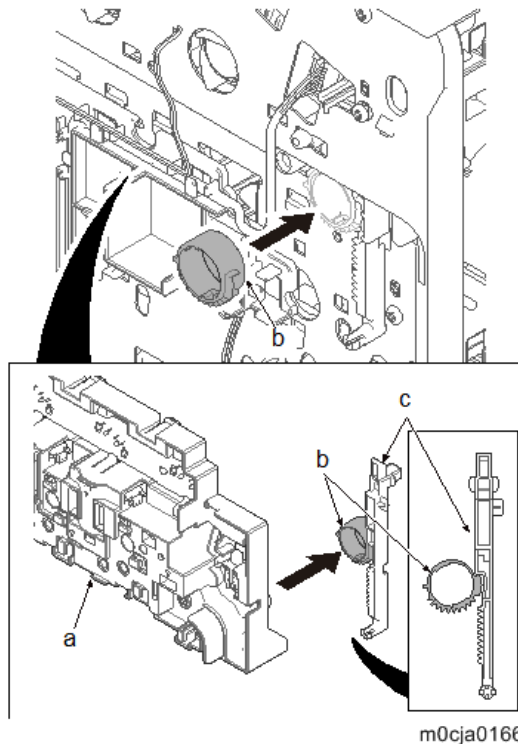

m0cja0166

## 4.Replacement and Adjustment

### Lift Motor (M9)

1. Remove the lower left cover. ([Lower Left Cover](#))
2. Disconnect all 24 connectors and FFCs from the engine relay PCB (PCB21) (a).

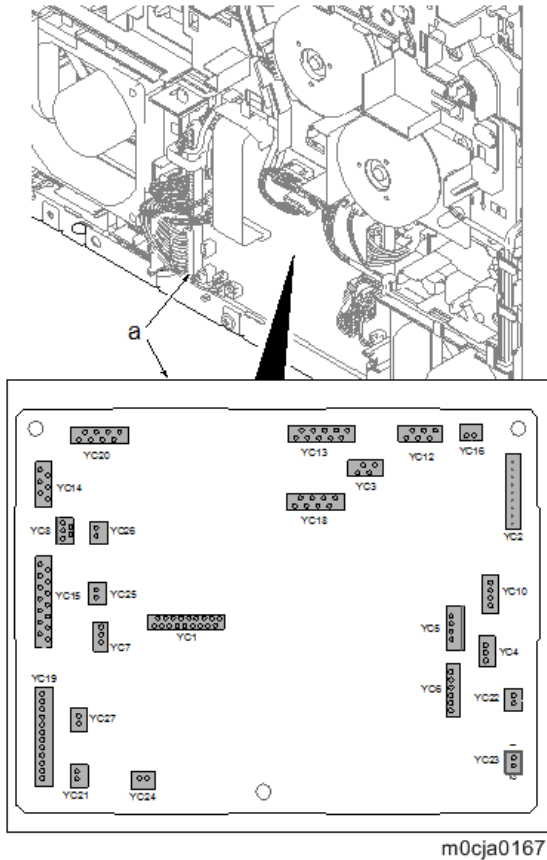

3. Remove three screws (a)(M3x8).
4. Detach the engine relay PCB (PCB21) (b).

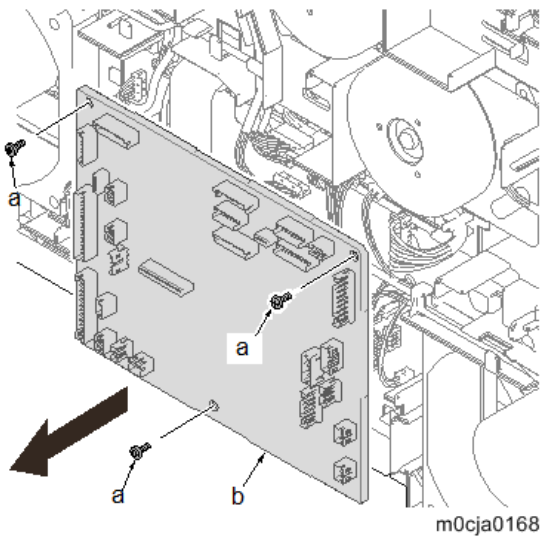

5. Disconnect the connector (b) of the lift motor (M9) (a).

- 6.** Release the wire from ten hooks (c).

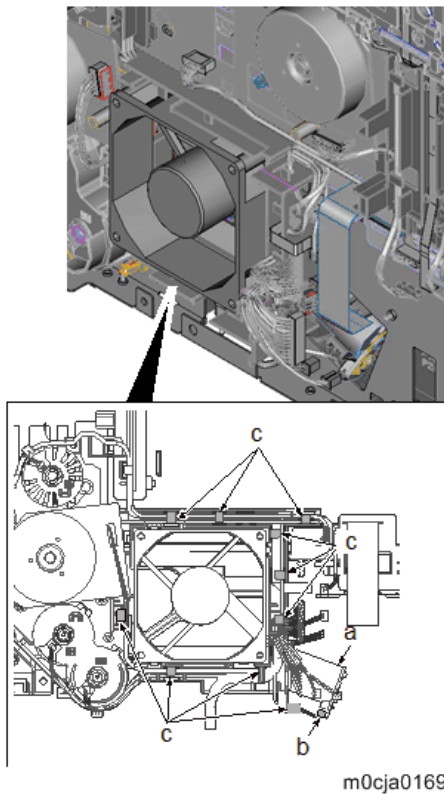

- 7.** Release four hooks (a).

- 8.** Remove the rear left duct (b).

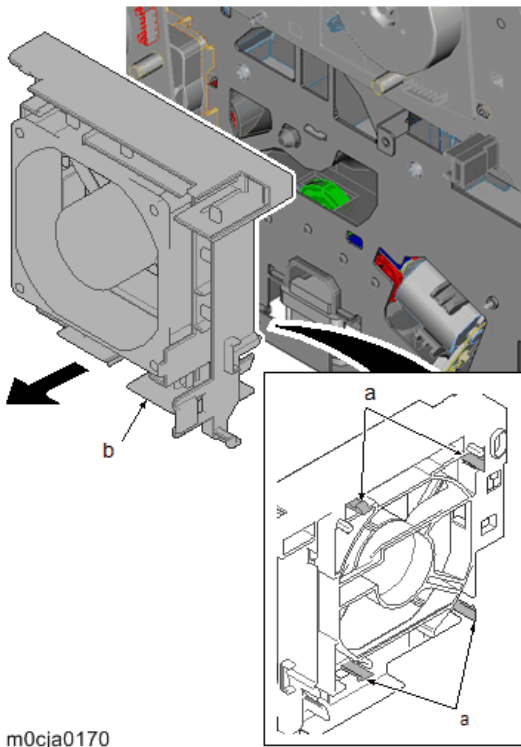

- 9.** Release two hooks (a).

- 10.** Remove the lift motor (M9) (b).

- 11.** Check the paper feed drive unit and clean or replace it if necessary.

## 4.Replacement and Adjustment

### 12. Reattach the parts in the original position.

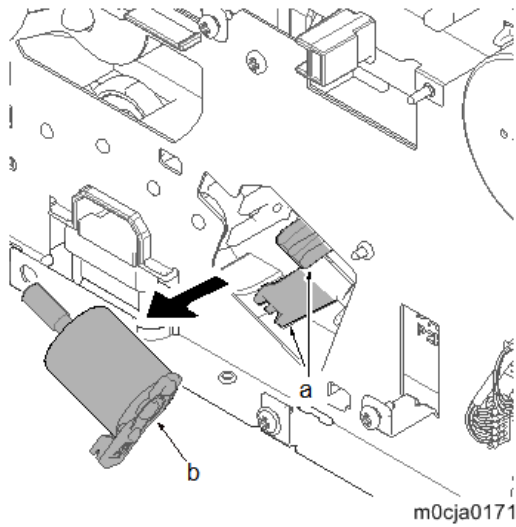

#### ★ Important

- Apply one drop of grease (VSSG9005: MOLYKOTE EM-50L) on the gear surface when attaching the new lift motor (M9) (a).

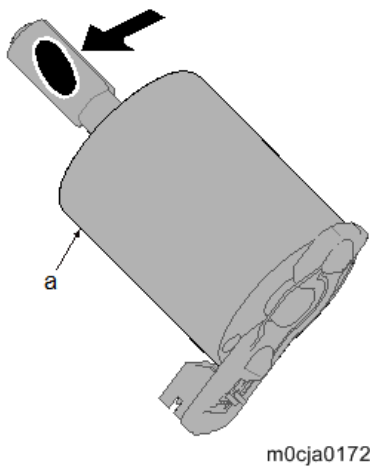

- Insert the boss (c) to the positioning hole (b) of the lift motor (M9) (a) and reattach it.

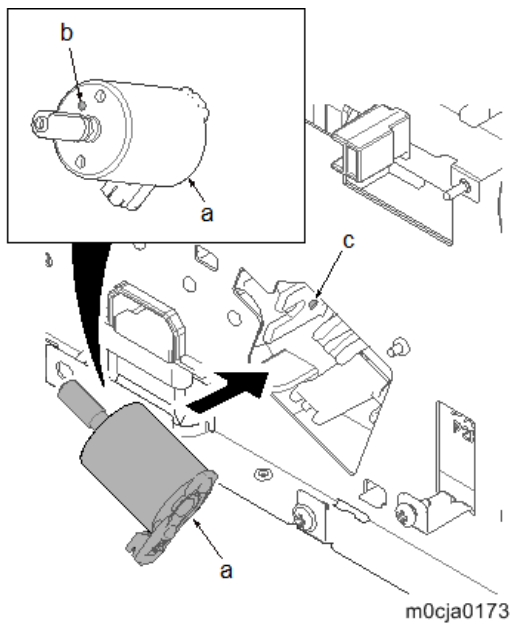

**13.** Attach the lift motor (M9) (a) after confirming it is not run over the rib (b).

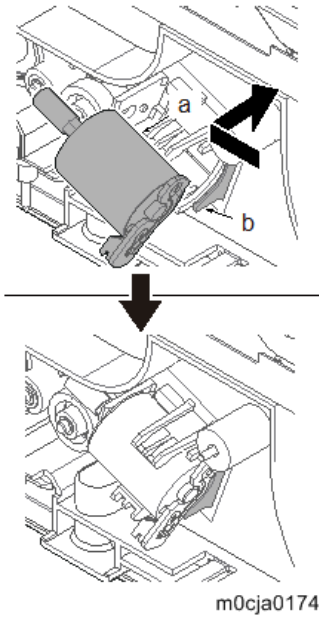

## Duplex Unit

---

### Duplex unit

---

- 1.** Open the rear cover (a).

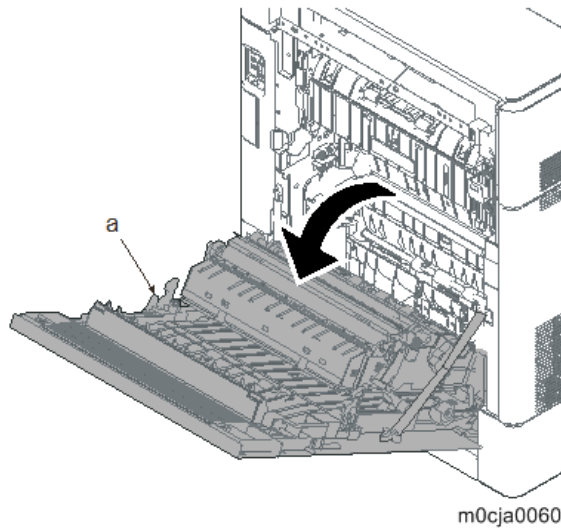

- 2.** Pull the conveying stopper (a) toward the machine right side and rotate it by using a flat-blade screwdriver (b).
- 3.** Release the hook (c) of the conveying stopper (a) from the rib (d) and pull the conveying stopper

(a) out.

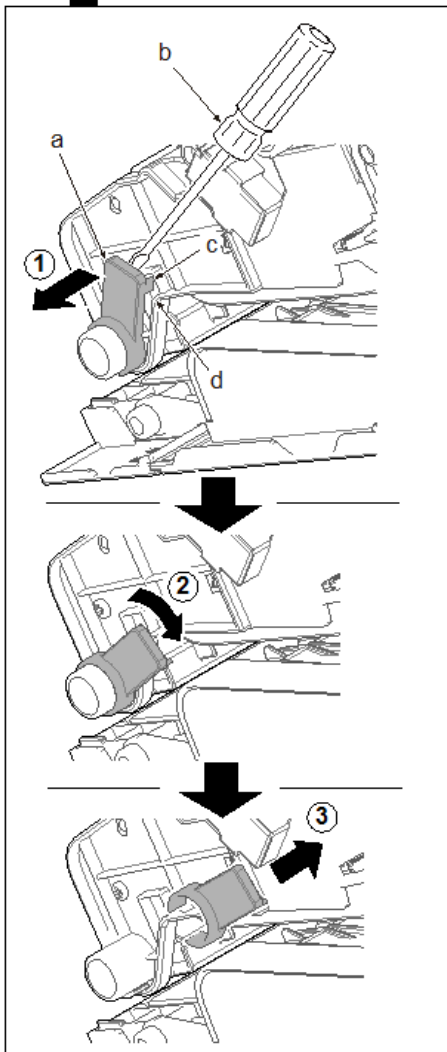
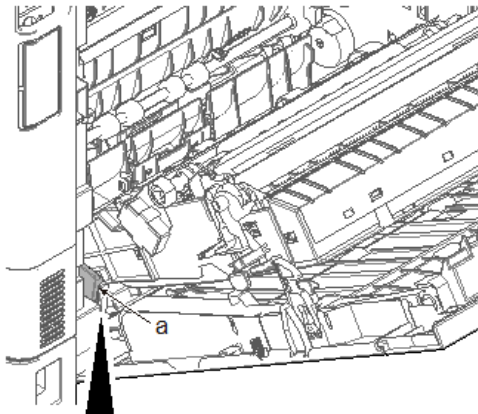

m0cja0122

- 4.** Slide the duplex paper conveying unit (a) toward the machine right side.
- 5.** Release the fulcrum part of the duplex paper conveying unit (a) at the machine left side, and pull

#### 4.Replacement and Adjustment

the unit out toward the machine rear side.

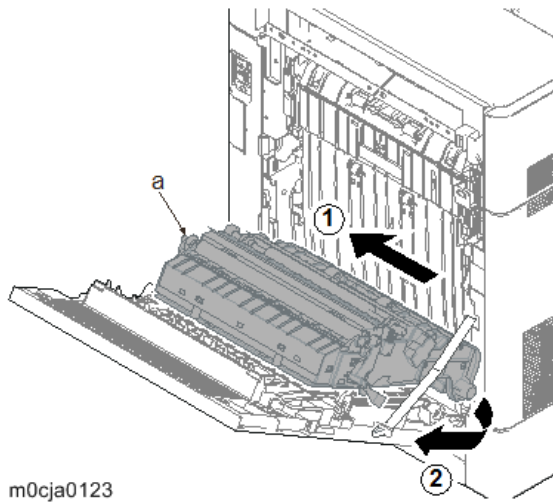

## Electrical Components

### Controller Box

#### Controller Box

- 1.** Remove the middle right cover. ([Middle Right Cover](#))
- 2.** Remove the controller box cover [A].

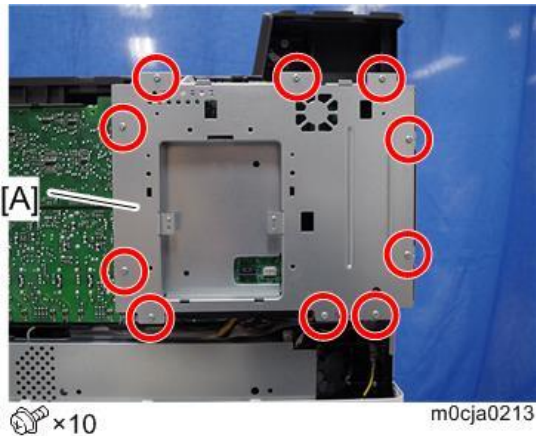

- 3.** Disconnect the FFC [A] from the controller board (PCB3).
- 4.** Remove the bracket [B] from the controller box.

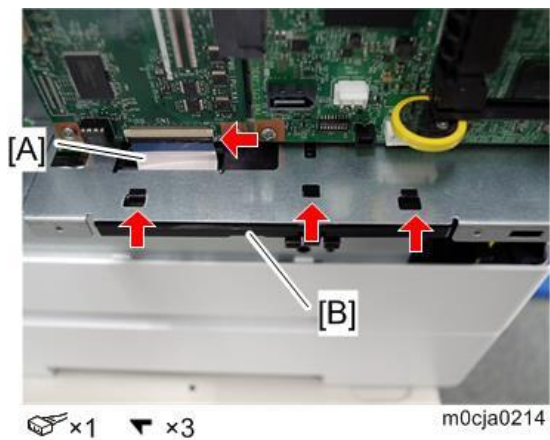

## 4.Replacement and Adjustment

### ★ Important

- Open the connector lock [A] before you disconnect the FFC.

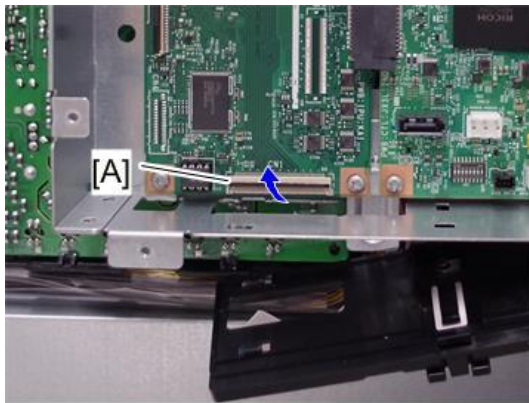

m0cja0215

## 5. Remove the controller box [A].

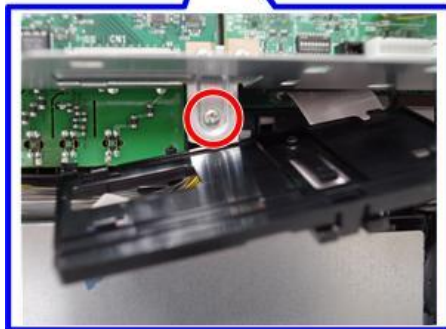
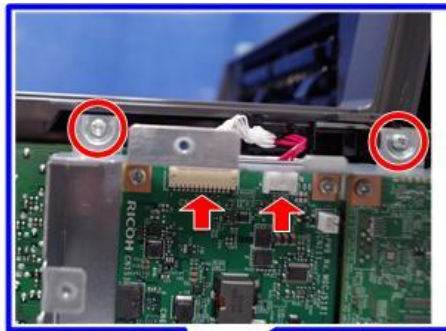

⚙️ x5 📦 x3

m0cja0216

---

## Controller Board (PCB3)

---

### Controller Board (PCB3)

---

**★ Important**

- Keep NVRAMs away from any objects that can cause static electricity. Static electricity can damage NVRAM data.

- 1.** Remove the controller box. ([Controller Box](#))
- 2.** Remove the slot cover [A].

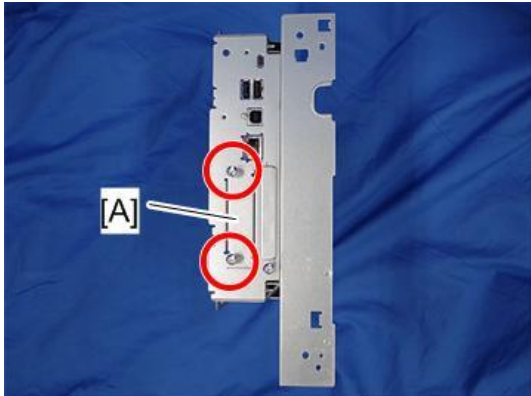

⚙️ x2

m0cja0217

- 3.** Remove the controller board (PCB3) [A] with the BiCU (PCB2) [B].

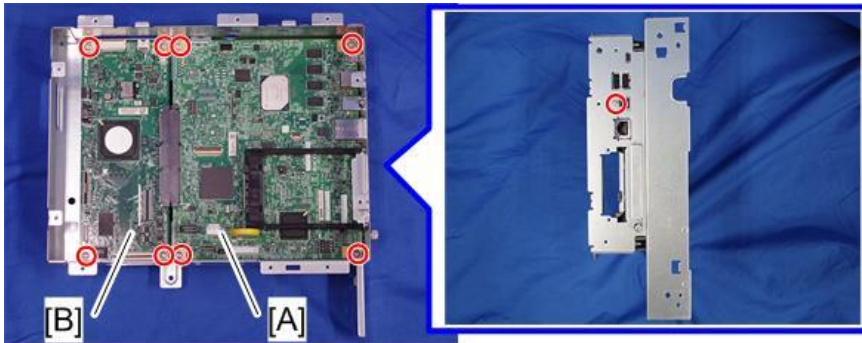

⚙️ x9

m0cja0218

**↓ Note**

- Be careful not to damage the backside of the controller board (PCB3) [A] and the BiCU (PCB2) [B].

## 4.Replacement and Adjustment

4. Remove the controller board (PCB3) [A] from the BiCU (PCB2) [B].

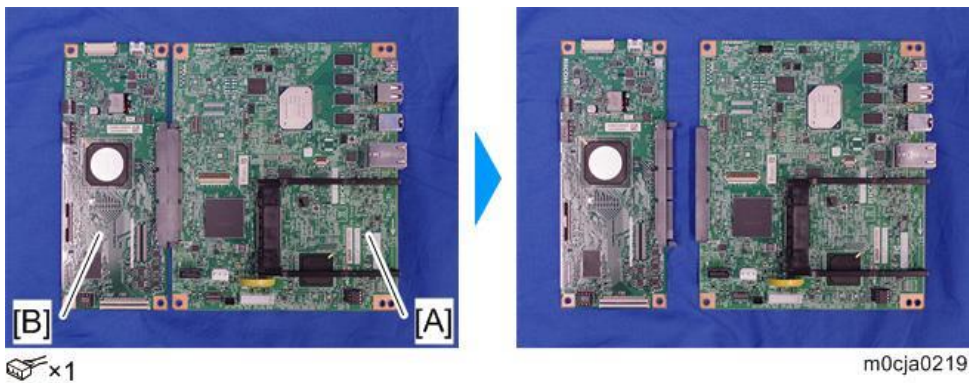

5. Remove the two guide rails [A] from the controller board (PCB3) [B].

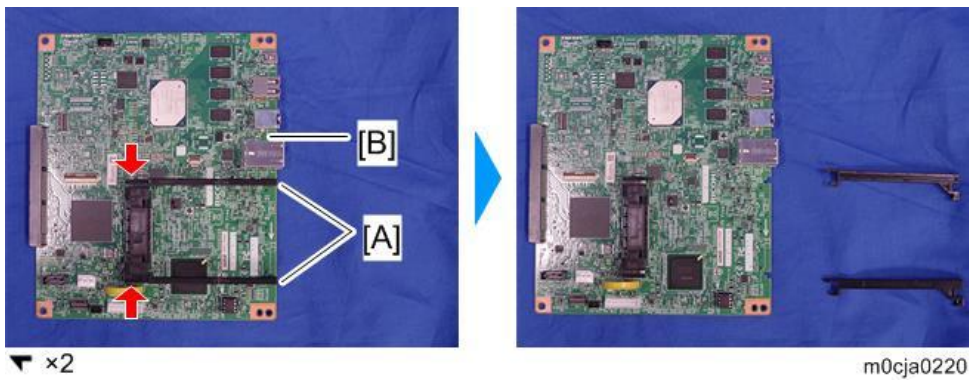

6. Remove the NVRAM [A] from the old controller board (PCB3) and install them on the new controller board (PCB3).



### ★ Important

- Make sure the NVRAM [A] is installed at the correct mounting location and orientation. Install the NVRAM so that the indentation on the NVRAM corresponds with the mark [B] on the controller board (PCB3).
- Incorrect installation of the NVRAM will damage both the controller board (PCB3) and NVRAM.

### NVRAM on the controller board (PCB3)

### ★ Important

- SC195 (Machine serial number error) will be displayed if you forget to attach the NVRAM.
- If you mounted the NVRAM in the wrong direction, it will cause a short circuit in the controller

board (PCB3) and the NVRAM, and each component will need to be replaced.

- Installing a new NVRAM initializes SPs and issues an SC. Reset the SC with the procedure below.

- 1.** Make sure that you have the SMC report (Factory SP Settings). This report comes with the machine. ([SMC Storage](#))
- 2.** Output the SMC log using one of the following methods:  
To print SMC log data, execute SP5-990-001.  
To save SMC log data to an SD card, execute SP5-992-001 (SMC List Card Save Function).
- 3.** Turn OFF the main power.
- 4.** Insert a blank SD card in the SD Card Slot 1, and then turn ON the main power.
- 5.** Use SP5-824-001 to upload the NVRAM data from the controller board (PCB3).
- 6.** Make sure the customer has a backup of their address book data. If not, obtain the backup by referring to SP5-846-051.

**★ Important**

- The address data stored in the machine will be discarded later during this procedure. So be sure to obtain a backup of the customer's address book data.
- Note that the counters for the user will be reset when doing the backup/restore of the address book data.
- If the customer have a backup of the address book data, use their own backup data for restoring. This is because there is a risk that the data cannot be backed up properly depending on the NVRAM's condition.

- 7.** Turn OFF the main power and unplug the power cord.
- 8.** Turn ON the main power again to discharge the residual charge.
- 9.** Replace the NVRAM with a new one.
- 10.** Turn ON the main power.

**★ Important**

- SC995 will be displayed after turning ON the main power.
- After turning ON the main power, the address book data will be cleared.

- 11.** Turn OFF/ON the main power with the SD card where the NV-RAM data has been uploaded in SD slot 1.
- 12.** Download the NV-RAM data stored in the SD card to the brand-new NV-RAM using SP5-825-001 (NV-RAM Data Download).

**↓ Note**

- The download will take a few minutes.

- 13.** Turn OFF the main power and remove the SD card from SD Card Slot 1.
- 14.** Turn ON the main power.
- 15.** Restore the original settings of the following SPs, by referring to the SMC data obtained in step 2.

**↓ Note**

- SP5-825-001 does not download the following SP data to the new NV-RAM. You must set

## 4.Replacement and Adjustment

it manually.

- SP5-193-001 (External Controller Info. Settings)

**16.** Ask the customer to restore their address book. Or restore the address book data using SP5-846-052 (UCS Setting: Restore All Addr Book), and ask the customer to ensure the address book data has been restored properly.

### ★ Important

- If you have obtained a backup of the customer's address book data, delete the backup immediately after the NVRAM replacement to avoid accidentally taking out the customer's data.

**17.** Output the SMC log using one of the following methods:

To print SMC log data, execute SP5-990-001.

To save SMC log data to an SD card, execute SP5-992-001 (SMC List Card Save Function).

### ↓ Note

- Check that the counters are reset.

### ★ Important

- Try the following if NVRAM upload (SP5-824-001) or download (SP5-825-001) cannot be done.
- Check the SP values that changed on the SMC you printed out in step 2. Adjust the values manually. Make sure that the values of SP5-045-001 and SP5-302-002 are the same as before replacing.

### ↓ Note

- If a message tells you need an SD card to restore displays after the NVRAM replacement, create a "SD card for restoration" and restore with the SD card. Refer to [Encryption Key Restoration](#).

---

## BiCU (PCB2)

---

- 1.** Remove the controller board (PCB3) with the BiCU (PCB2) from the controller box. ([Controller Board \(PCB3\)](#))
- 2.** Remove the BiCU (PCB2) [A] from the controller board (PCB3) [B].

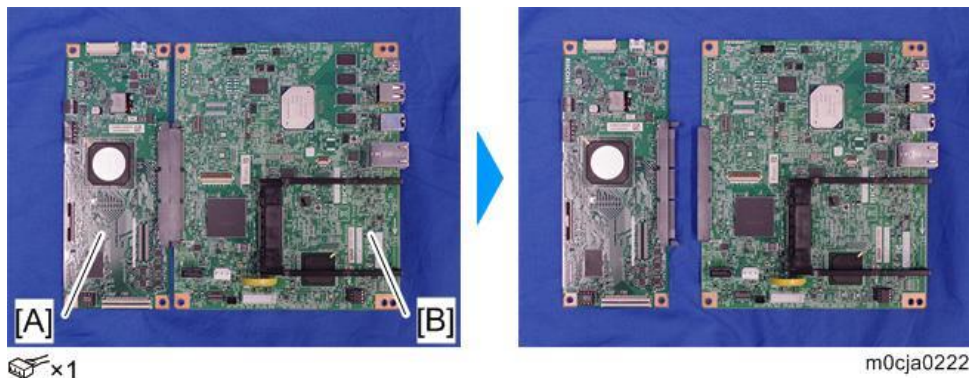

- 3.** Remove the NVRAM [A] from the old BiCU (PCB2) and attach it to the new BiCU (PCB2).

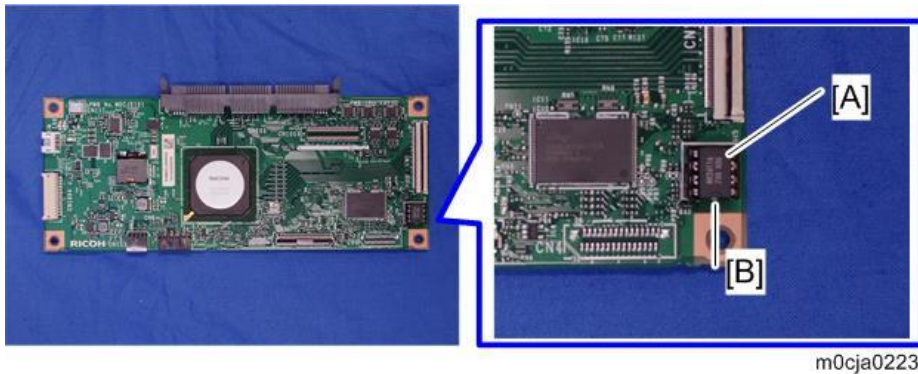

**Note**

- Attaching the used NVRAM to the new BiCU (PCB2) allows users to use old data such as SP settings.
- Make sure the serial number is input in the machine for the NVRAM data with SP5-811-004. If not, SC995-001 occurs. Install a NVRAM [A] so that the indentation [B] on the NVRAM corresponds with the mark on the BiCU (PCB2). Incorrect installation of the NVRAM will damage both the BiCU (PCB2) and NVRAM.

#### Replacing the NVRAM (EEPROM) on the BiCU (PCB2)

- 1.** Make sure that you have the SMC report (Factory SP Settings). This report comes with the machine. ([SMC Storage](#))
- 2.** Output the SMC data ("ALL") using SP5-990-001/SP5-992-001.
- 3.** Turn OFF the main power.
- 4.** Insert a blank SD card in the SD Card Slot 1, and then turn ON the main power.
- 5.** Use SP5-824-001 to upload the NVRAM data from the BiCU (PCB2).
- 6.** Turn OFF the main power and unplug the power cord.
- 7.** Replace the NVRAM on the BiCU (PCB2) with a new one.

**Important**

- Install a new NVRAM [A] so that the indentation [B] on the NVRAM corresponds with the mark on the BiCU (PCB2). Incorrect installation of the NVRAM will damage both the BiCU (PCB2) and NVRAM.

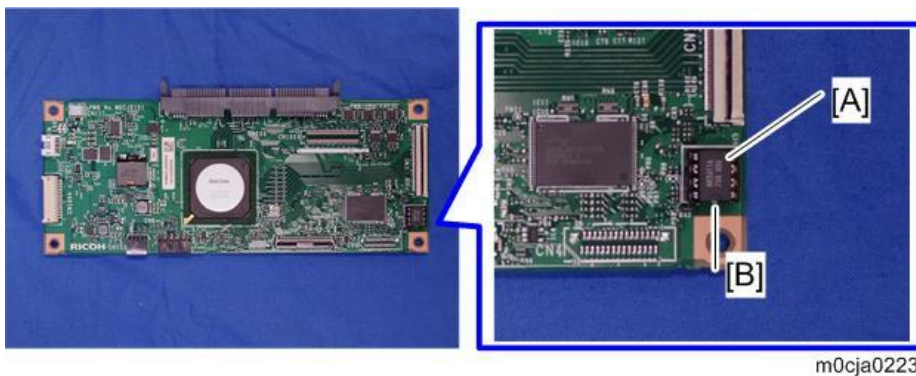

#### 4.Replacement and Adjustment

**8.** Plug in the power cord, and then turn ON the main power.

**★ Important**

- After changing the EEPROM, some SPs do not have the correct values.
- Because of this, step 9 must be done.

**9.** Set the machine serial number SP5-811-001, area selection SP5-996-001, CPM set SP5-882-001.

**↓ Note**

- For information on how to configure the above SPs, contact the supervisor in your branch office.

**10.** Turn the main power OFF/ON.

**11.** Execute SP5-801-002 "Memory Clear Engine".

**12.** Turn OFF the main power, and then turn it back ON.

**13.** From the SD card where you saved the NV-RAM data in step 5, download the NV-RAM data with SP5-825-001.

**14.** Turn OFF the main power, and then remove the SD card from SD slot 1.

**15.** Turn ON the main power.

**16.** Check the SMC report (Factory SP Settings) from step 1, and set the user tool and SP settings so they are the same as before.

---

#### Main/Engine PCB (PCB1)

---

**1.** Remove the HVP (PCB19). ([HVP \(PCB19\)](#))

**2.** Open the FFC connector lock [A] and remove the FFC (with bracket) [B] from the main/engine PCB (PCB1).

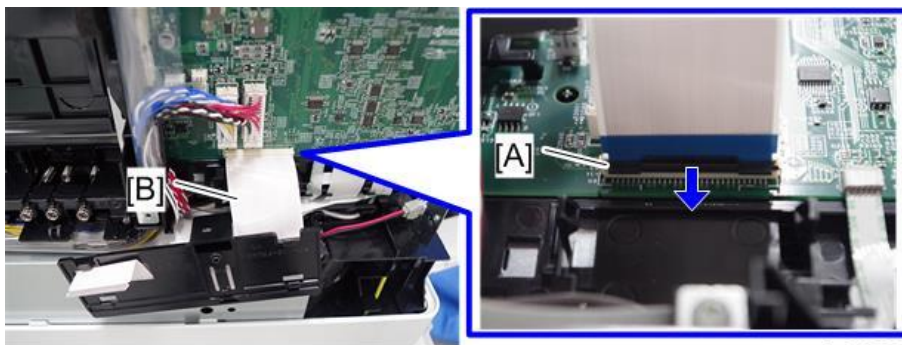

m0cja0233

**3.** Open the wire alignment film [A] by releasing two square holes [B][C] from the hooks of the wire

guide.

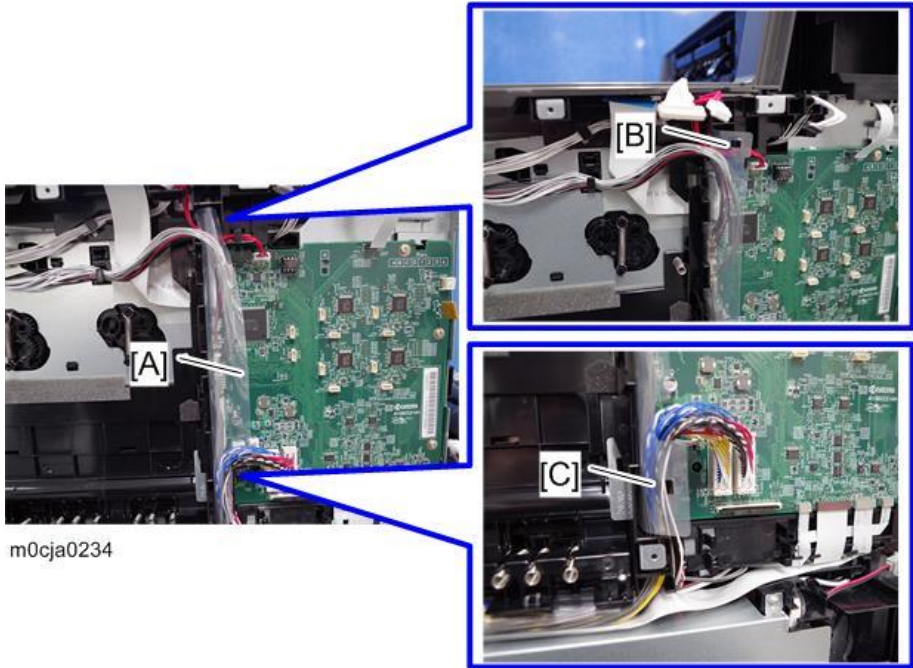

4. Disconnect all the connectors and the FFCs from the main/engine PCB (PCB1) [A].

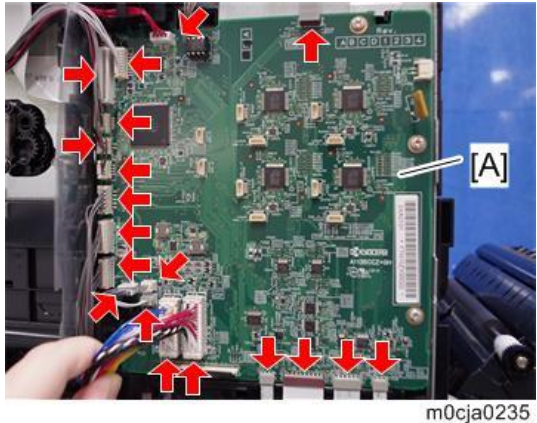

5. Release the wire from the hooks of the wire guide [A] and remove the wire guide [A] from the

#### 4.Replacement and Adjustment

main/engine PCB (PCB1).

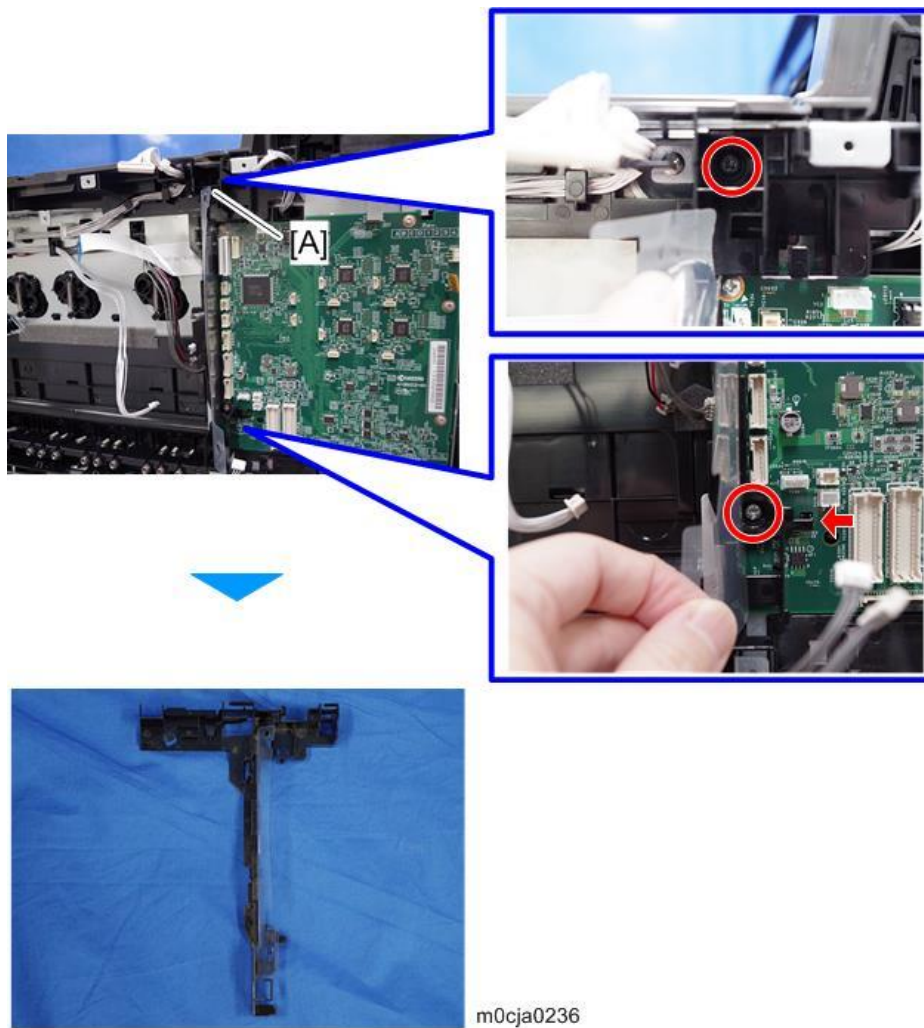

⚙️ ×2   ▾ ×1

**6.** Remove the main/engine PCB (PCB1) [A].

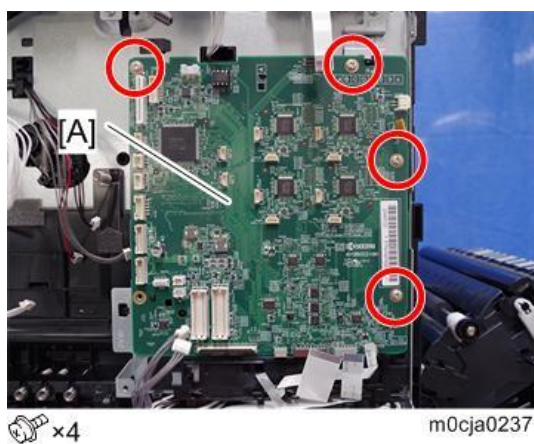

⚙️ ×4

**7.** Remove the EEPROM [A] from the old main/engine PCB (PCB1) and attach it to the new

main/engine PCB (PCB1).

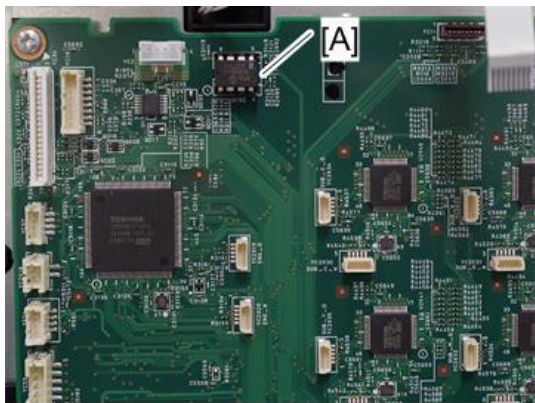

m0cja0238

### Replacing the NVRAM (EEPROM) on the Main/Engine PCB (PCB1)

- 1.** Make sure that you have the SMC report (Factory SP Settings). This report comes with the machine.
- 2.** Output the SMC data ("ALL") using SP5-990-001/SP5-992-001.
- 3.** Turn OFF the main power and unplug the power cord.
- 4.** Replace the NVRAM on the Main/Engine PCB (PCB1) with a new one.

**★ Important**

- Install a NVRAM [A] so that the indentation [B] on the NVRAM corresponds with the mark on the Main/Engine PCB (PCB1). Incorrect installation of the NVRAM will damage both the Main/Engine PCB (PCB1) and NVRAM.

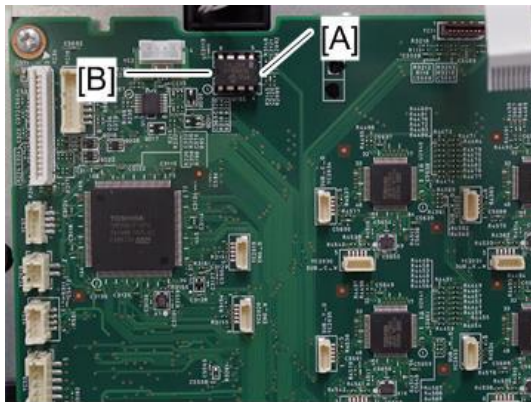

m0cja0245

- 5.** Plug in the power cord.
- 6.** Open the rear cover, and then turn ON the main power.  
Opening the rear cover prevents the machine from entering the initialization process.
- 7.** Execute SP5-901-00x "All Data Initialize".

Destination	SP
AA	SP5-901-008
NA / LA (120 V)	SP5-901-007
EU / LA (230 V)	SP5-901-006

## 4.Replacement and Adjustment

### Note

Do not use SP5-901-009 (Oceania).

- 8.** Turn OFF the main power.
- 9.** Close the rear cover, and then turn ON the main power again.  
The machine initialization starts. This takes several minutes.
- 10.** Set SP4-698-003 “Factory mode” to “1”.

### Important

Do not open the front cover, and do not turn OFF/ON the main power until step 10.

### Note

- For information on how to configure the above SP, contact the supervisor in your branch office.
- Displayed number will be changed to “0” soon after setting SP4-698-003 to “1”. This is normal operation and the SP has been executed correctly.

- 11. AP only:** Set SP5-805-002 to 1.  
**NA/EU:** Leave it in the default setting (0).
- 12.** Turn OFF the main power, then turn ON the main power again.
- 13.** Check the SMC report (Factory SP Settings) from step 1 or 2, and set the user tool and SP settings so they are the same as before.

---

## HVP (PCB19)

---

- 1.** Remove the controller box. ([Controller Box](#))
- 2.** Remove the front cover. ([Front Cover](#))
- 3.** Slightly tilt the PCB toward you and release the FFC.

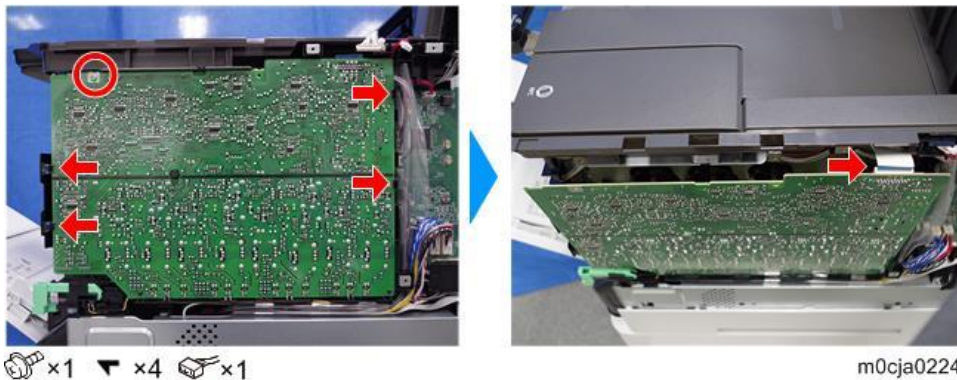

- 4.** Tilt the HVP (PCB19) [A] to 90 degrees and pull it out toward you. The lower hook [B] on the PCB

might break if removing it without push it down.

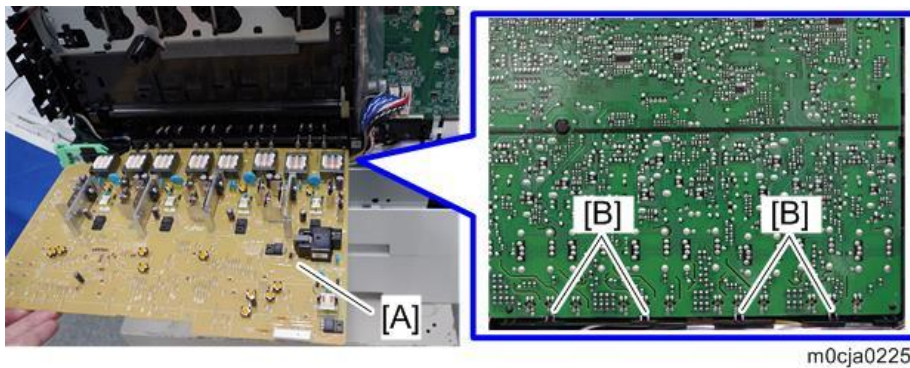

**★ Important**

When reattaching the HVP (PCB19) (d), insert the lower part of the PCB into four of the lower hooks (b) and insert the left and right positioning pins (c) into the holes. Then, raise the PCB and apply two hooks each at the left and right side. After reattaching the HVP (PCB19) (d), check that it is secured with two hooks at the each left and right side and four hooks (b).

(If the hook is not fastened, the image failure might appear.)

Also, check the terminal spring (e) contacts the terminal (f). (Check from The PCB hole)

Terminal : Lower side: 12 Left side: 1

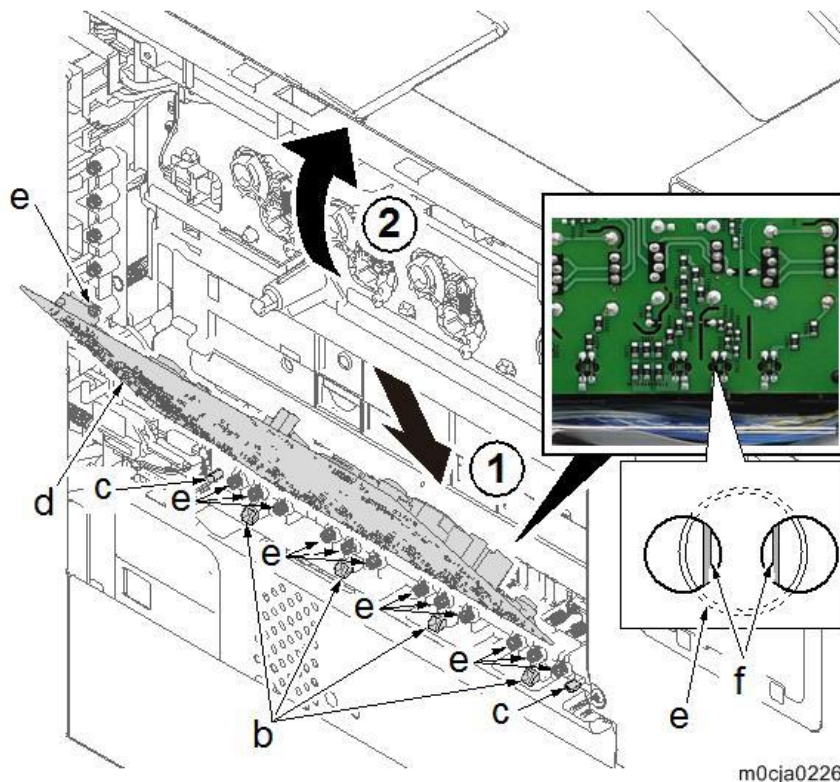

## HVP 2 (PCB20)

- 1.** Remove the front cover. ([Front Cover](#))
- 2.** Tilt the operation panel to a horizontal position.
- 3.** Disconnect the connector (a).

#### 4.Replacement and Adjustment

- 4.** Remove the screw (b)(M3x8).

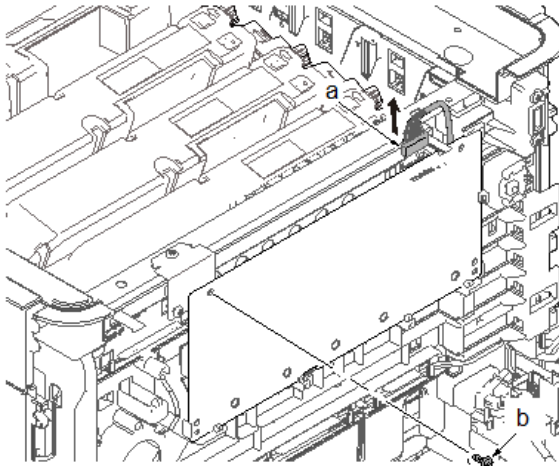

m0cja0227

- 5.** Release two hooks (a) and remove the HVP 2 (PCB20) (b).

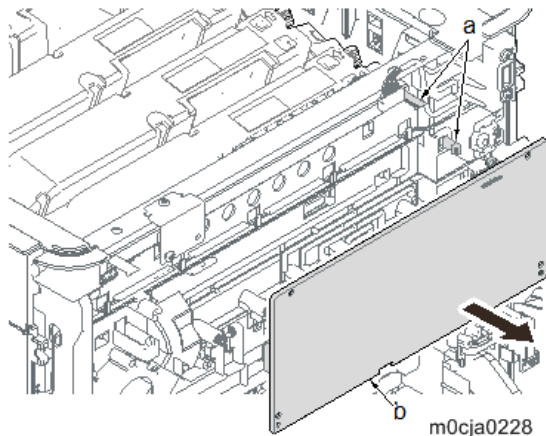

m0cja0228

**★ Important**

- When reattaching the HVP 2 (PCB20) (a), insert the lower part of the PCB into four of the lower hooks (b) and insert two right hooks while lift up it.

Also, check the terminal spring (c) contacts the terminal (d). (Check from The PCB hole)

Terminal: Lower side: 5

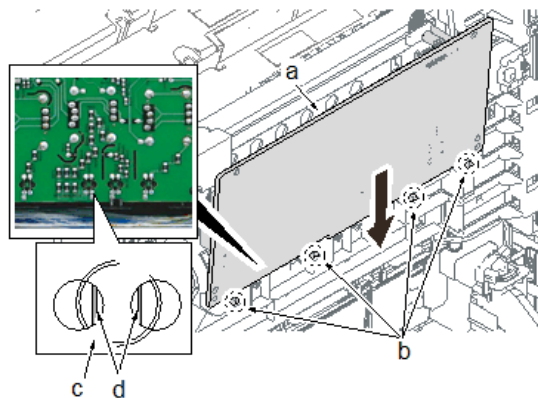

m0cja0229

## PSU (PCB9)

**⚠ CAUTION**

- Turn OFF the main power switch and unplug the power cord before replacing the PSU (PCB9).
- Do not touch the areas outlined in red in the following diagrams when replacing the PSU (PCB9). Residual charge on the board may cause electric shock.

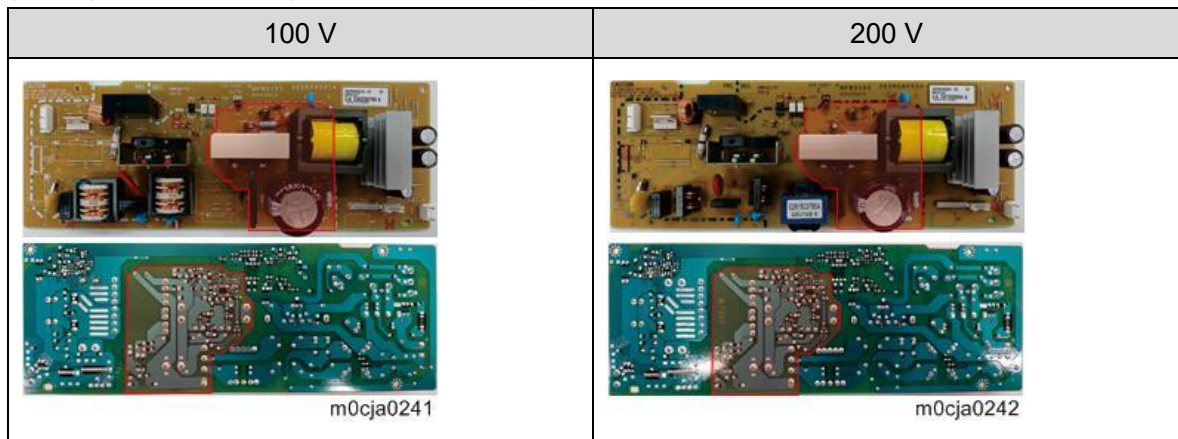

- 1.** Remove the lower right cover. ([Lower Right Cover](#))
- 2.** Remove two screws (a)(M3x8: P-tite)
- 3.** Remove the screw (b)(M3x8: S-tite)
- 4.** Release the hook (c).
- 5.** Remove the power supply shield (d). The screw (a) and (b) are different and secure them at the original place.

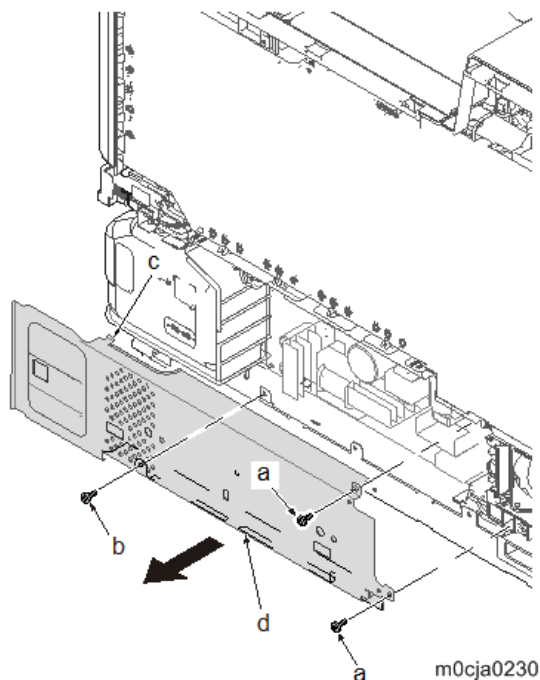

- 6.** Disconnect all the connectors from the PSU (PCB9) (a). (five connectors)
- 7.** Remove two screws (b)(M3x8).

## 4.Replacement and Adjustment

**8.** Release two hooks (c).

**9.** Remove the PSU (PCB9) (a).

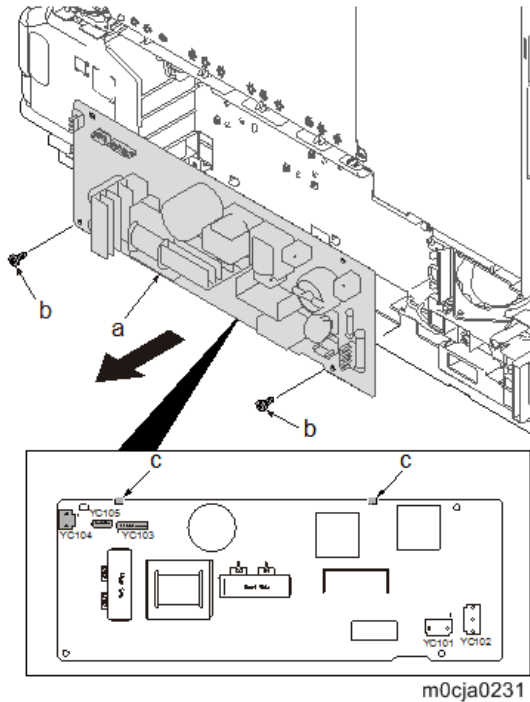

### ★ Important

- When reattaching the power supply shield (a), insert the lower two hooks (b) into the square holes (c) of the main unit and fasten the upper hook (d). Then, secure it with the screws (e).

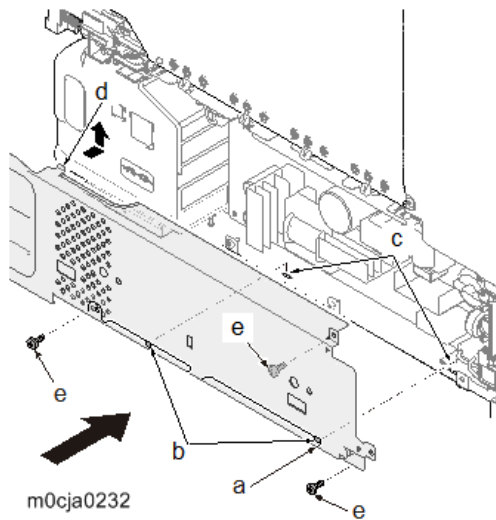

---

## Engine Relay PCB (PCB21)

---

**1.** Remove the lower left cover. ([Lower Left Cover](#))

**2.** Disconnect all the connectors and FFCs (24 connectors in total) from the engine relay PCB

(PCB21) (a).

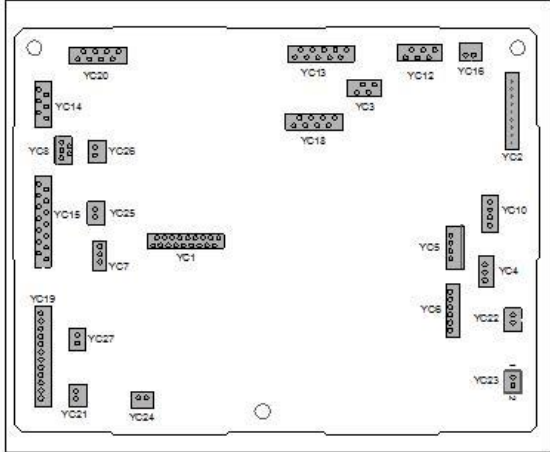
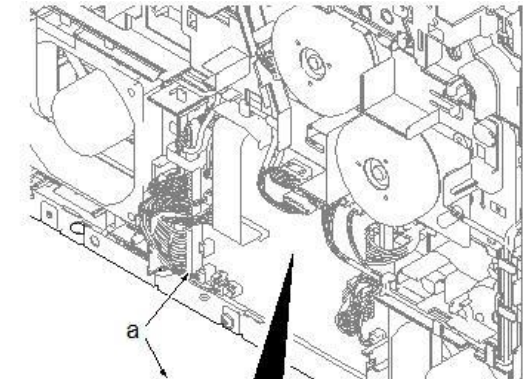

m0cja0239

**3.** Remove three screws (a)(M3x8).

#### 4.Replacement and Adjustment

4. Detach the engine relay PCB (PCB21) (b).

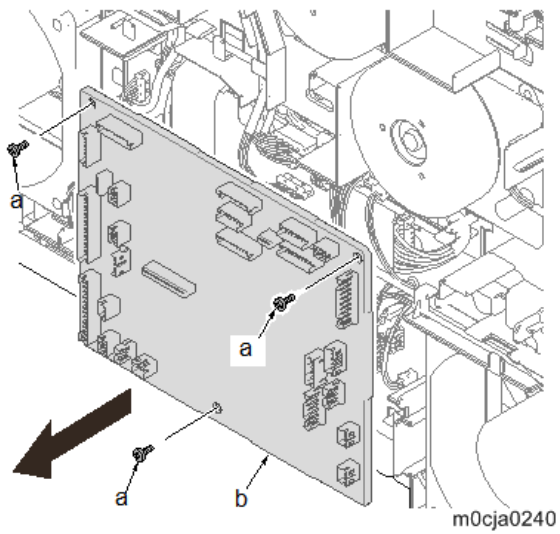

---

#### NFC Board (PCB4)

---

1. Lift the handle [A] and open the top tray [B].

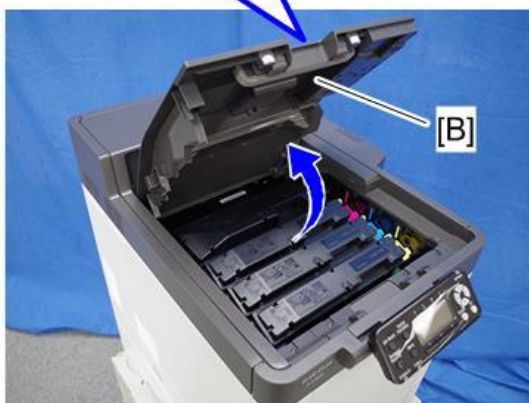

m0cja0050

- 2.** Release two hooks [A] with a flat-blade screwdriver and remove the cover [B].

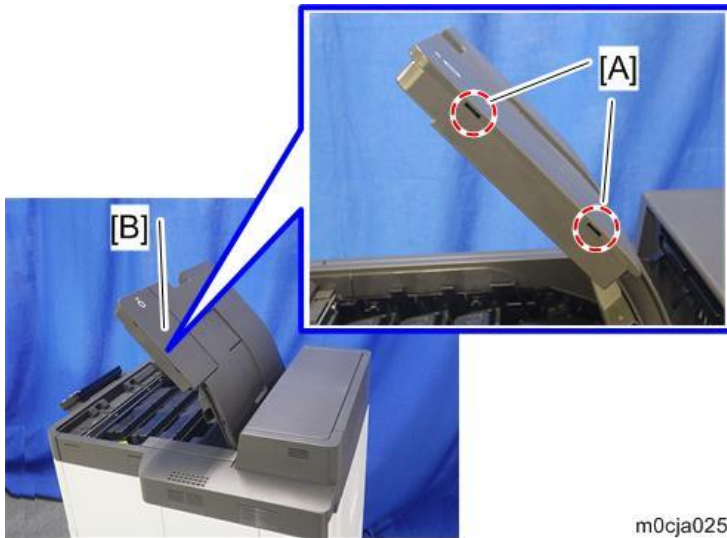

▼ x2

- 3.** Close the top tray [A].

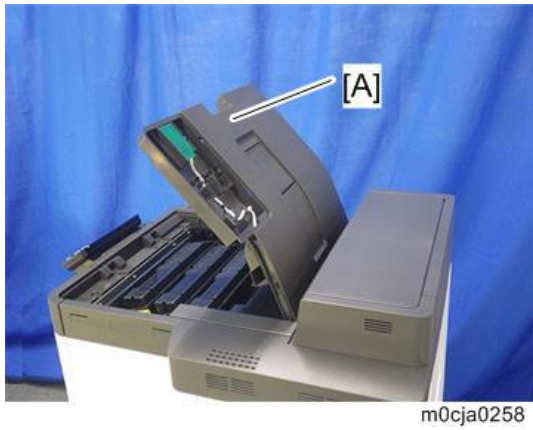

- 4.** Remove the NFC board (PCB4) [A].



▼ x3

#### 4.Replacement and Adjustment

- 5.** Disconnect the connector from the NFC board (PCB4) [A].

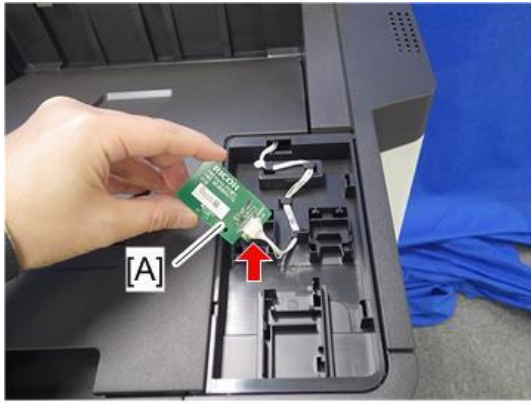

 x1

m0cja0260

## Fans

### ★ Important

- When reattaching the fan motor, be aware of the attachment direction (in-take/exhaust).

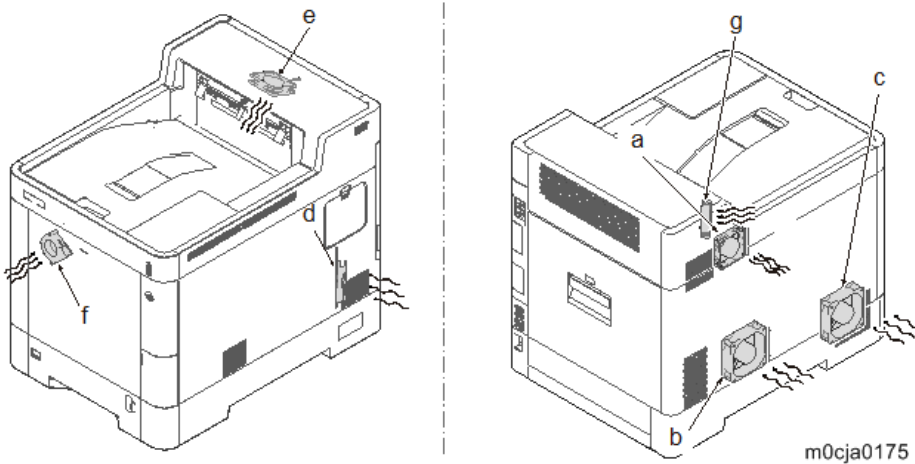

- a. Cartridge fan motor (FAN3): (Rating label: inside) in-take
- b. Laser unit fan motor1 (FAN5): (Rating label: inside) in-take
- c. Laser unit fan motor2 (FAN6): (Rating label: inside) in-take
- d. Power supply fan motor (FAN1): (Rating label: inside) in-take
- e. Exit fan motor (FAN7): (Rating label: lower) in-take
- f. Transfer fan motor (FAN4): (Rating label: inside) in-take
- g. Duplex fan motor (FAN2): (Rating label: inside) in-take

## Paper Feed Unit (Paper Feed Unit PB1150)

### Retard Roller Unit

1. Open the PF rear cover (a).

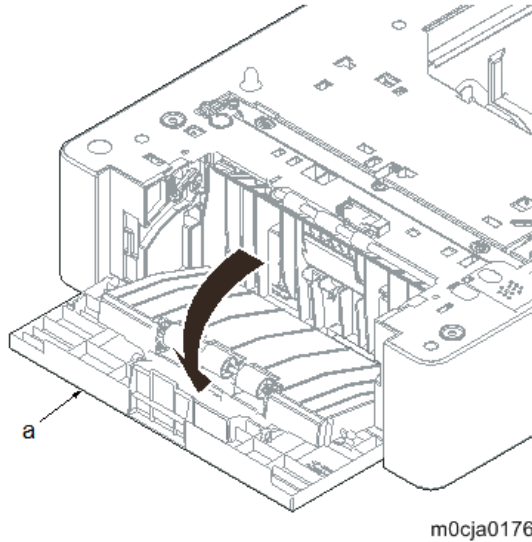

2. Release two hooks (a) using a flatblade screwdriver (b).
3. Remove the retard guide (c).

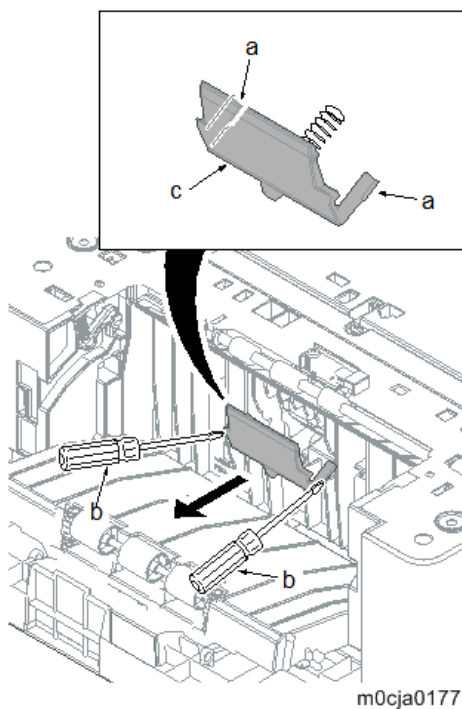

4. Remove the retard roller unit (a).
5. Check the retard roller unit and clean or replace it if necessary.
6. Reattach the parts in the original position.

**★ Important**

Install the cassette first when attaching the retard roller unit. The retard pressure release lever must be located at the machine front side from the retard roller unit to apply appropriate pressure.

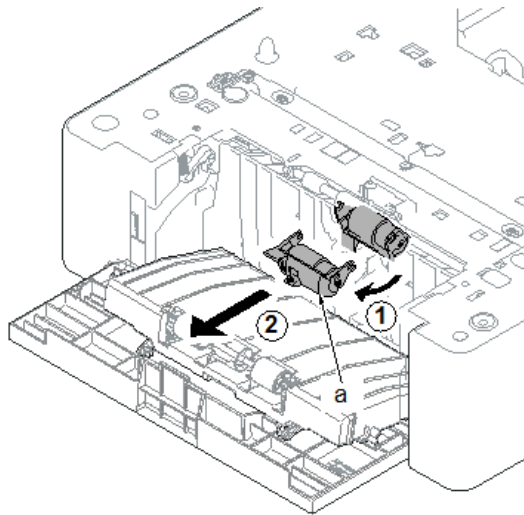

m0cja0178

---

### Paper Feed Roller and Pickup Roller

---

- 1.** Remove the retard roller unit. ([Retard Roller Unit](#))
- 2.** Remove the cassette (a) from the paper feeder (b).

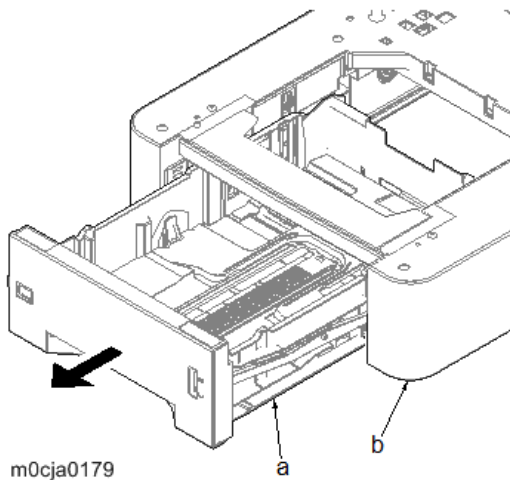

m0cja0179

- 3.** Place the paper feeder (a) while turning it over.

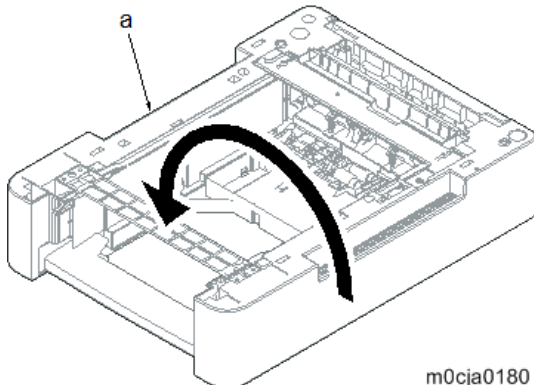

m0cja0180

- 4.** Push the lock lever (a).

#### 4.Replacement and Adjustment

- 5.** Slide the feed roller pin (b) straight and release the lock.

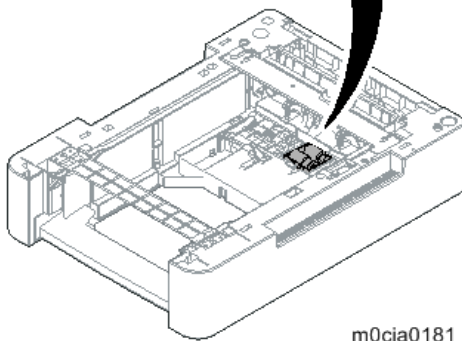
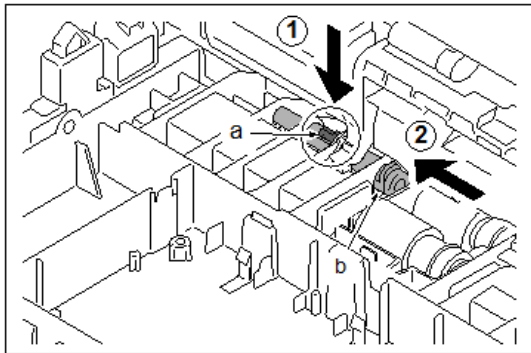

m0cja0181

- 6.** Push the lock lever (a).  
**7.** Detach the paper feed roller unit (b).

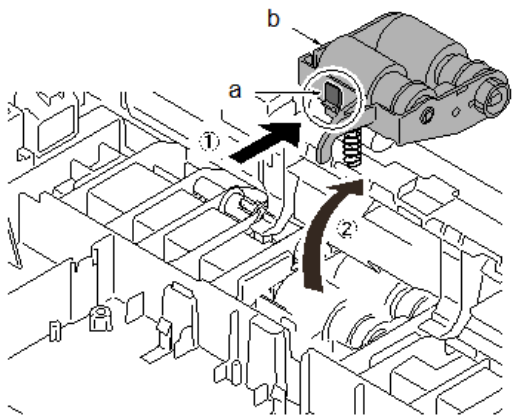

m0cja0182

- 8.** Remove the paper feed roller [A] and/or pick-up roller [B].

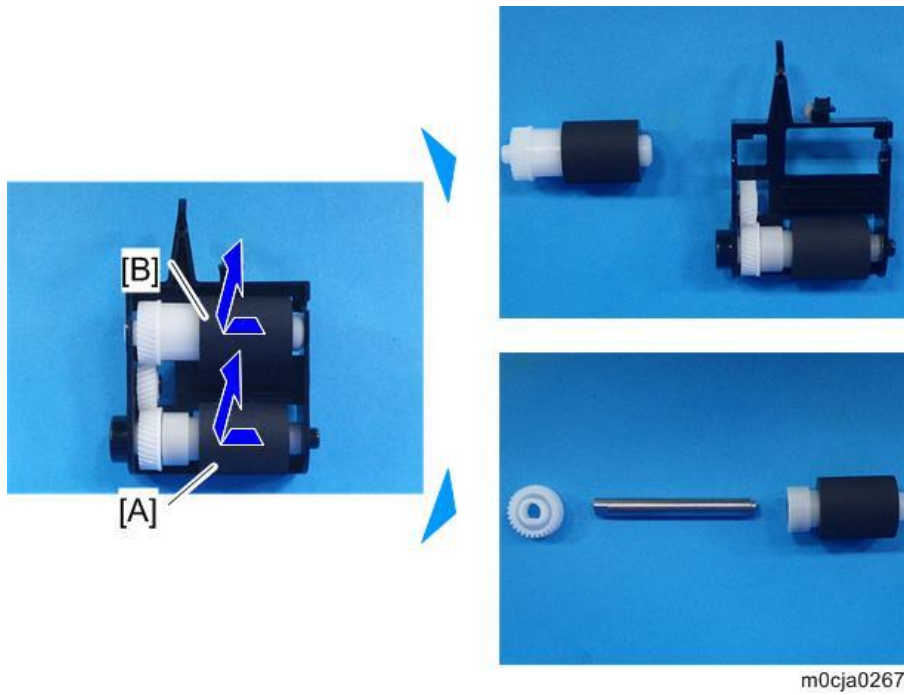

---

## Main Board

---

- 1.** Remove the cassette (a) from the paper feeder (b).

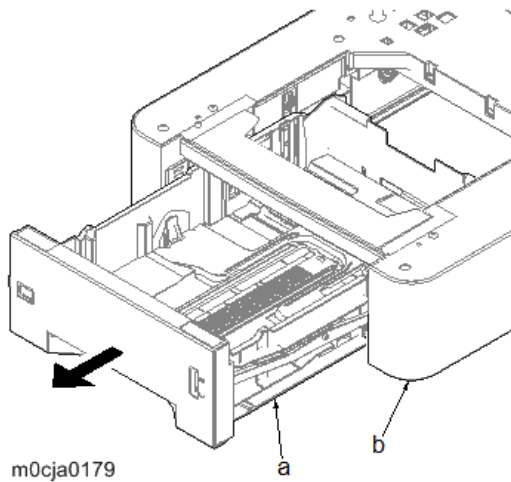

- 2.** Place the paper feeder (a) while turning it over.

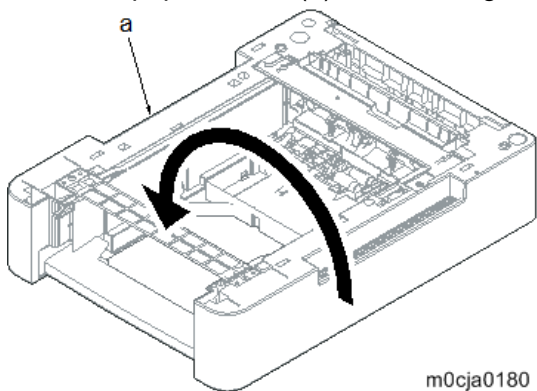

#### 4.Replacement and Adjustment

- 3.** Release two hooks (b) of the PCB cover (a) using a flat-blade screwdriver (c).

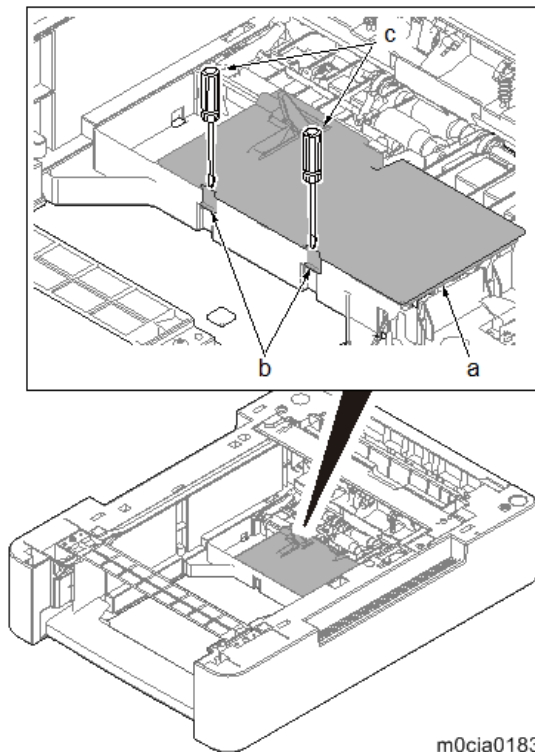

m0cja0183

- 4.** Detach the PCB cover (a).

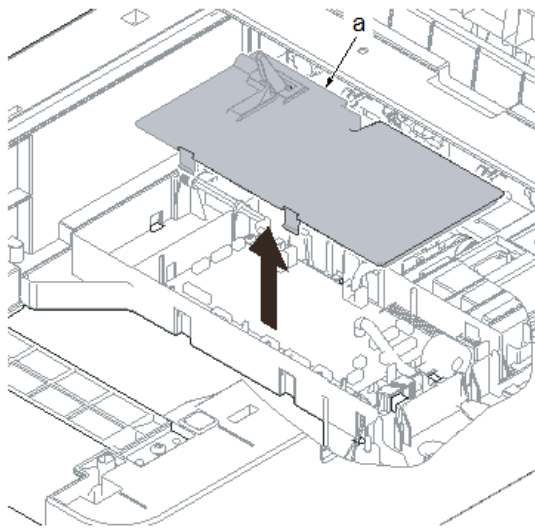

m0cja0184

5. Remove the actuator (a) and spring (b).

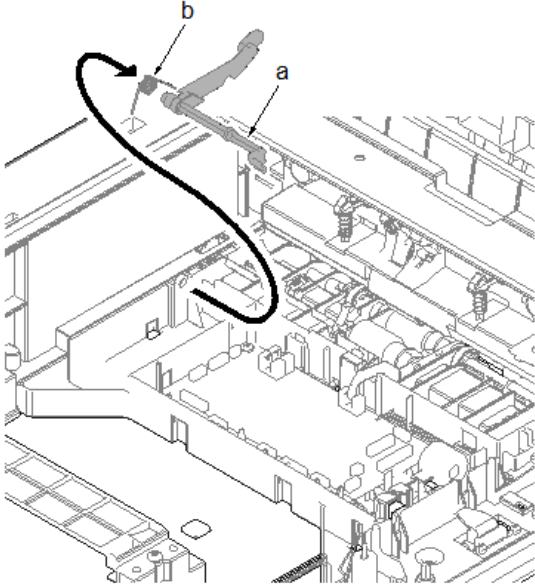

m0cja0185

6. Disconnect all the connectors from the PF main PCB (a). (10 connectors)

\*: YC10 connector is not used.

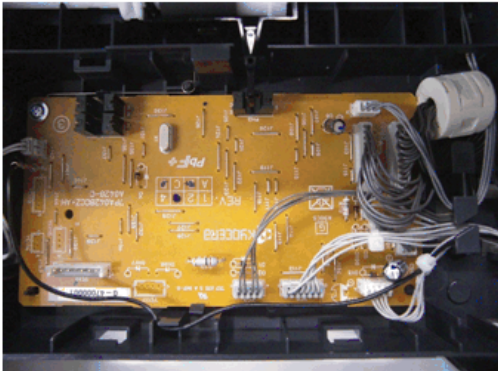
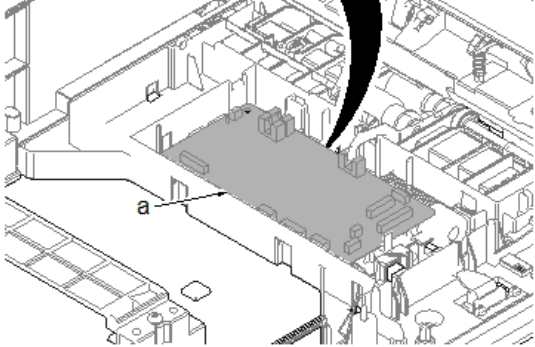
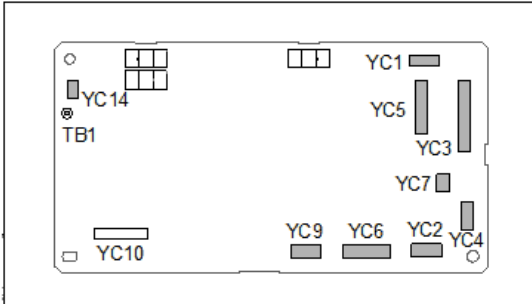

m0cja0186

#### 4.Replacement and Adjustment

**7.** Push the lock lever B (a).

**8.** Lift up the feed roller unit (b) to release the lock.

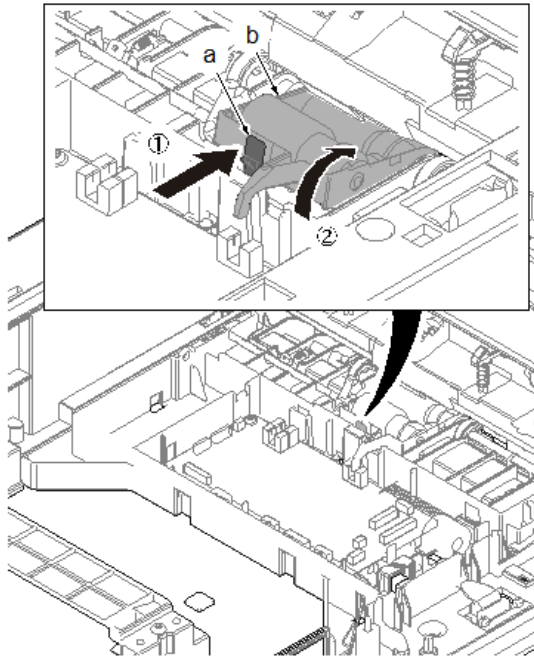

m0cja0187

**9.** Remove the screw (a)(M3x8).

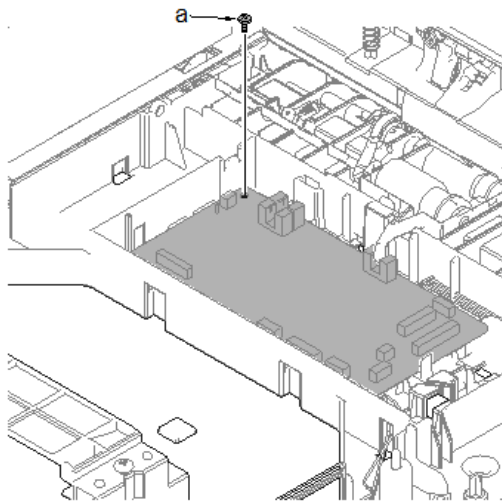

m0cja0188

**10.** Remove four hooks (a) and then remove the PF main PCB (b).

**11.** Check the PF main PCB and clean or replace it if necessary.

- 12.** Reattach the parts in the original position.

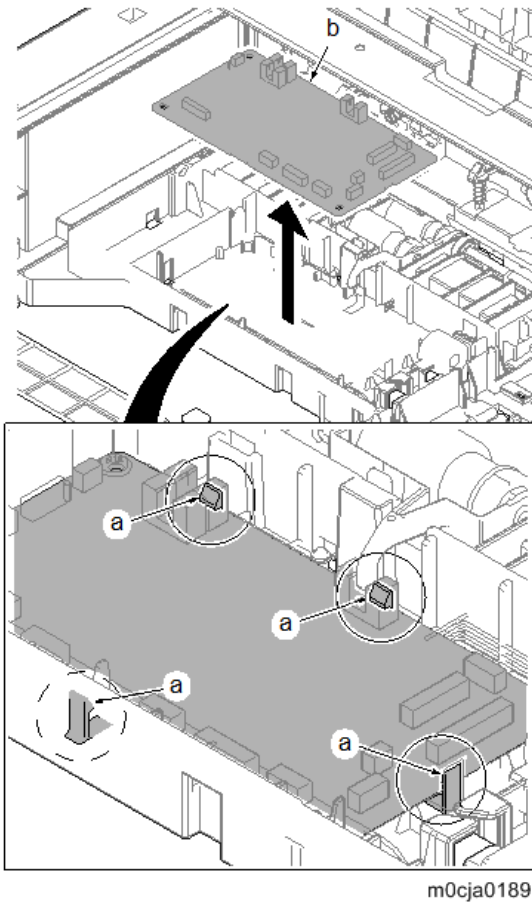

---

## Drive Unit

---

- 1.** Remove the cassette (a) from the paper feeder (b).

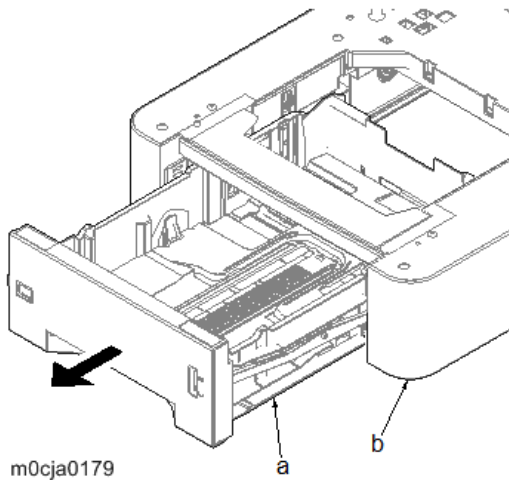

- 2.** Remove eight screws (a)(M3x10)

**★ Important**

Secure the screws in the order of the numbers.

#### 4.Replacement and Adjustment

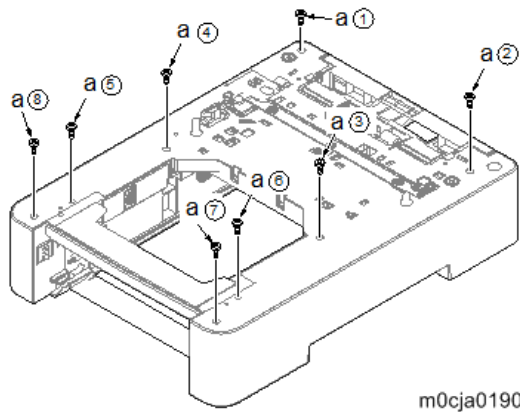

m0cja0190

- 3.** Place the paper feeder (a) while turning it over.

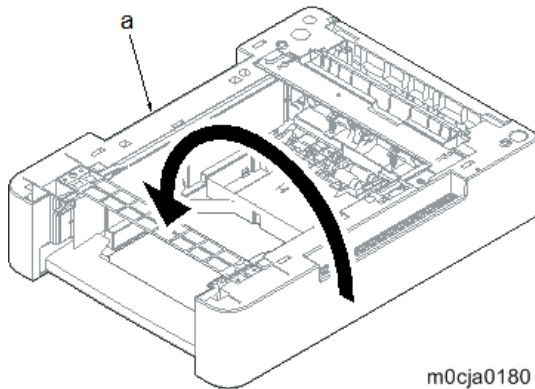

m0cja0180

- 4.** Release two hooks (b) of the PCB cover (a) using a flat-blade screwdriver (c).

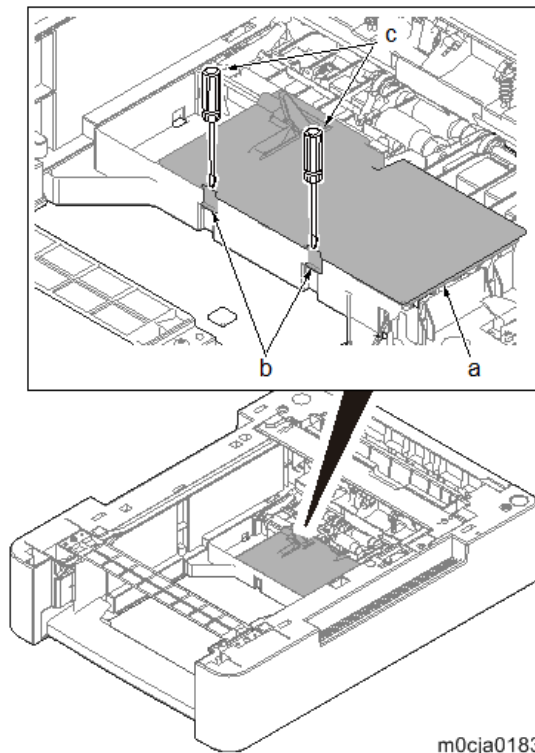

m0cja0183

- 5.** Detach the PCB cover (a).

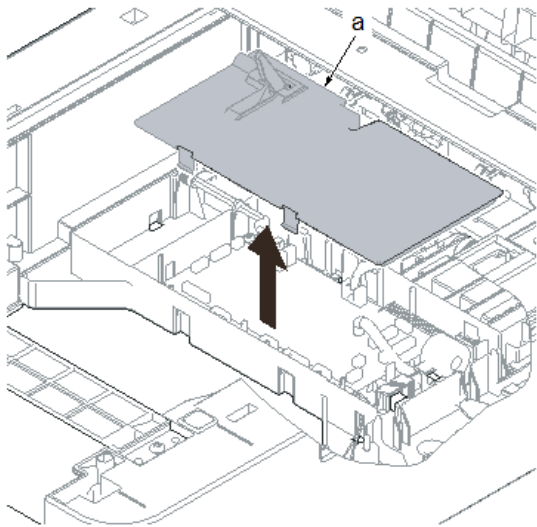

m0cja0184

- 6.** Remove the actuator (a) and spring (b).

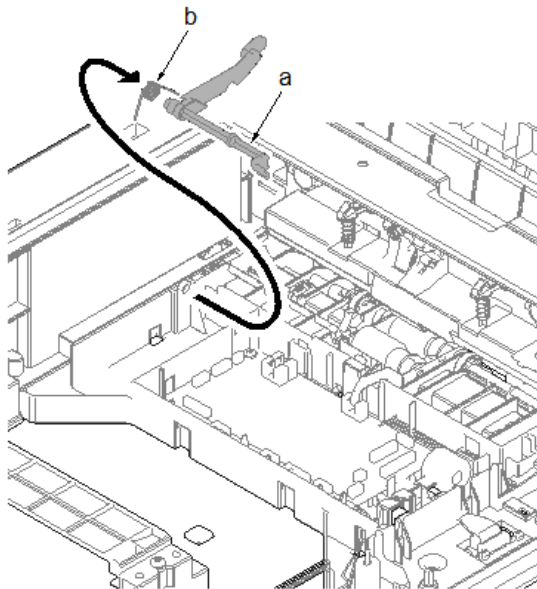

m0cja0185

- 7.** Disconnect nine connectors (b) from the PF main PCB (a).  
YC1 to YC7, YC9, TB1

#### 4.Replacement and Adjustment

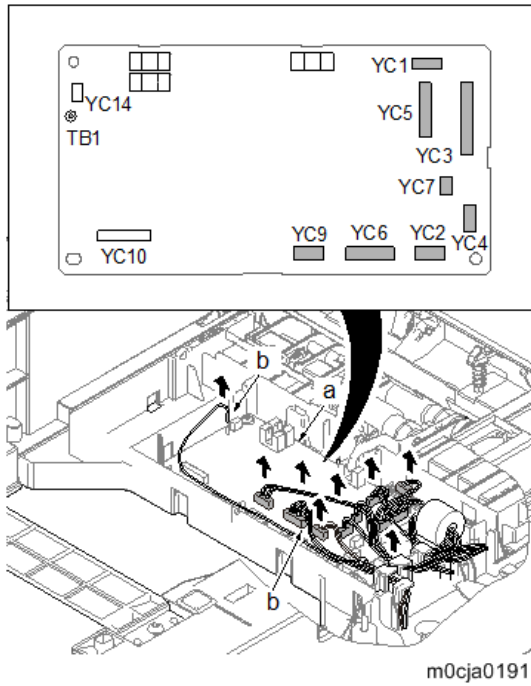

**8.** Remove the wire (a) from the hook (b).

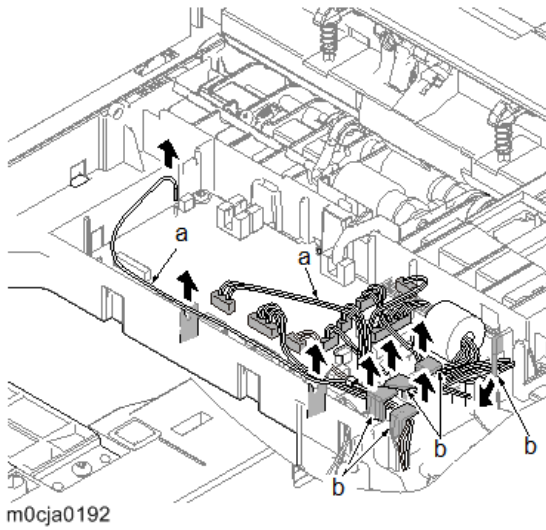

- 9.** Place the paper feeder while turning it over. Release the hook (a) using a flatblade screwdriver (b).

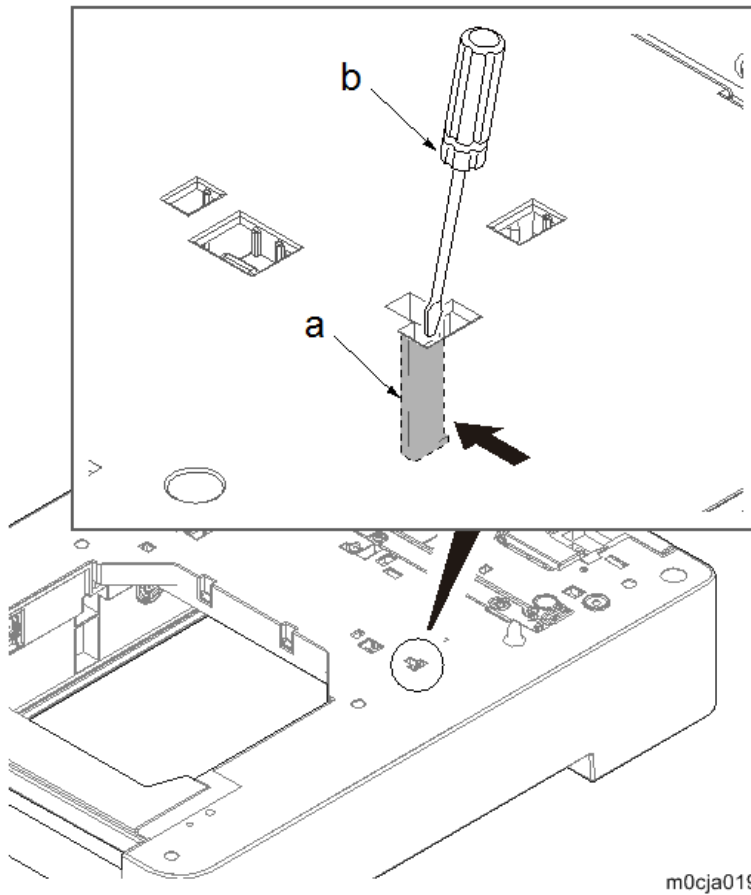

- 10.** Place the paper feeder while turning it over. Release the hook (a) using a flatblade screwdriver (b).  
\*: Release it while widening the cover with a flat-blad screwdriver.

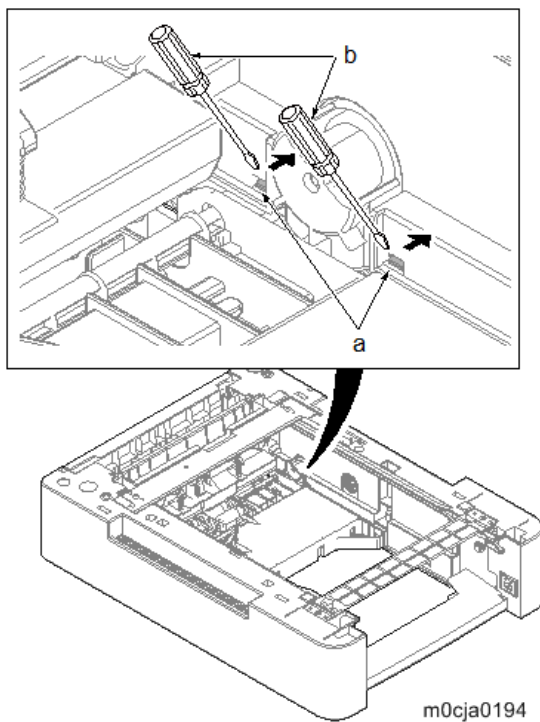

#### 4.Replacement and Adjustment

**11.** Lift up the paper feeder (b) and remove the upper cover (a).

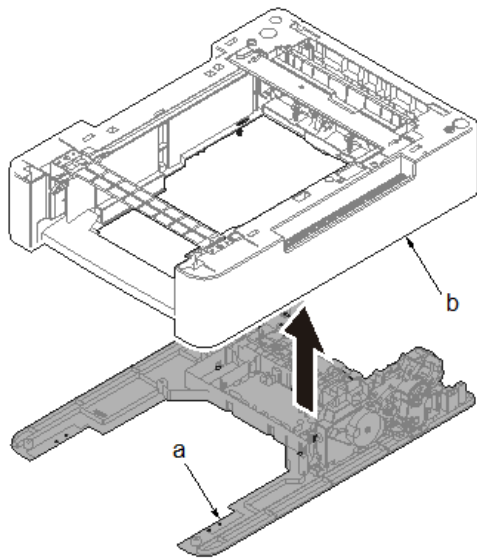

m0cja0195

**12.** Push the lock lever (a).

**13.** Slide the feed roller pin (b) straight and release the lock.

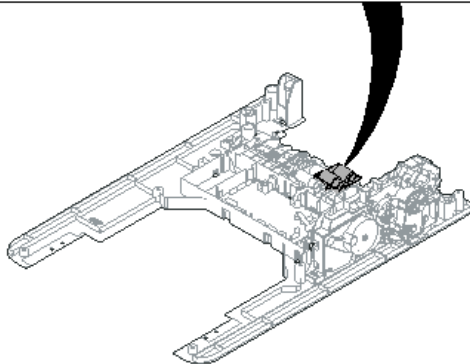
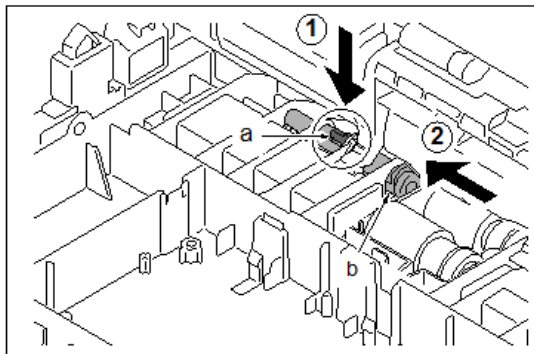

m0cja0196

**14.** Push the lock lever (a).

- 15.** Detach the paper feed roller unit (b).

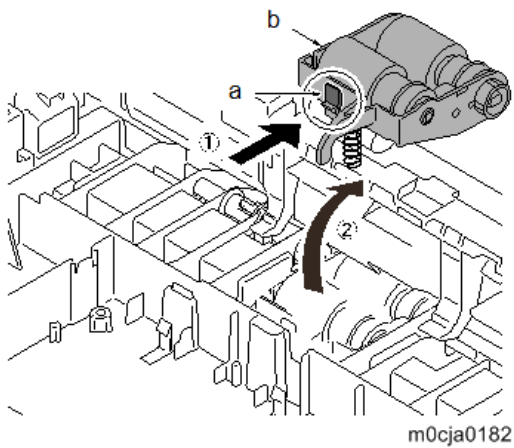

- 16.** Slide the feed roller drive pin (a) and release it from the drive joint (b).

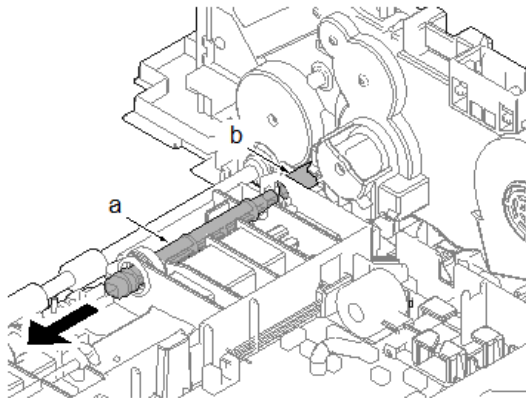

- 17.** Remove two screws (a)(M3x8).

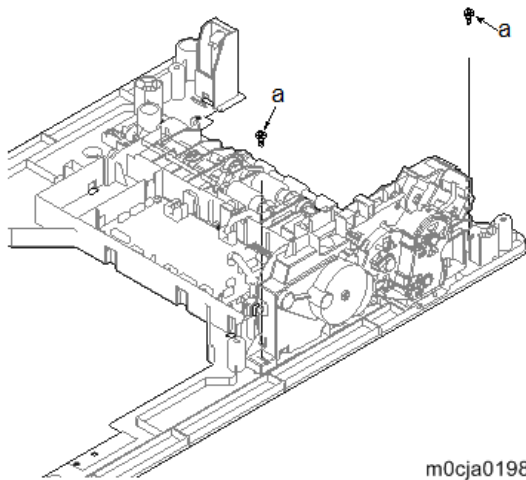

- 18.** Release the hook (a) with a flat-blade screwdriver (b) and remove the PF drive unit (c).

- 19.** Check the PF drive unit and clean or replace it if necessary.

## 4.Replacement and Adjustment

**20.** Reattach the parts in the original position.

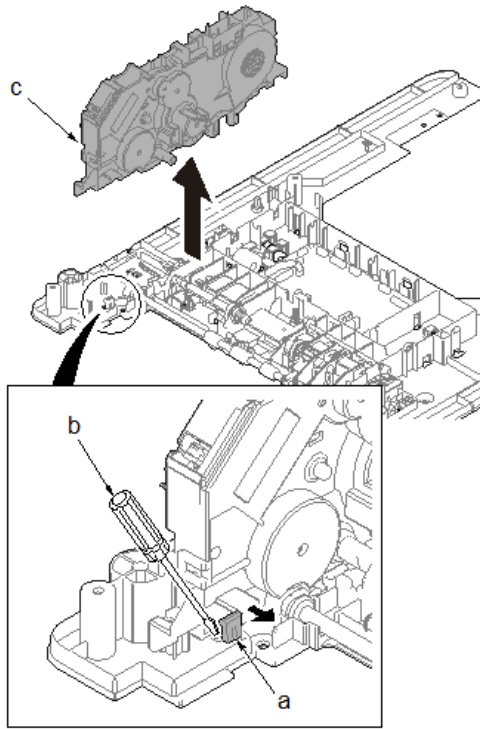

m0cja0199

### ★ Important

Before attaching the top cover (a), confirm the ground spring (b) is inserted in the hole on the main unit.

Attach the spring with its projection facing down.

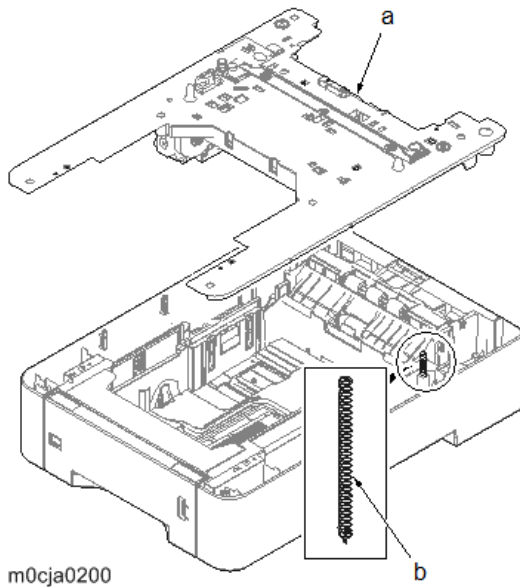

m0cja0200

# 5. System Maintenance

---

## Service Program Mode

---

### SP Tables

---

See "Appendices" for the following information:

- SP Mode Tables

## Firmware Update

---

### Overview

---

In order to update the firmware of this machine, it is necessary to download the latest version of firmware on a SD card. Insert the SD card in SD Card Slot 1.

---

### Procedure

---

#### ★ Important

- A SD card is a precision device, so when you handle an SD card, respect the following.
- When the power is switched ON, do not insert or remove a card.
- During installation, do not switch the power OFF.
- Since the card is manufactured to high precision, do not store it in a hot or humid location, or in direct sunlight.
- Do not bend the card, scratch it, or give it a strong shock.
- Before downloading firmware on an SD card, check whether write-protection of the SD card is canceled. If write-protection is enabled, an error code (error code 44, etc.) will be displayed during download, and the download will fail.
- Before updating firmware, remove the network cable from this machine.
- If SC818 is generated during software update, switch the power OFF -> ON, and complete the update which was interrupted.
- During software update, network cables, remove interface cables, wireless boards, etc., (so that they are not accessed during update).

### Update procedure

---

1. First download the software to be updated to the SD card.
2. Turn OFF the main power.
3. Insert the SD card straight in the SD Card Slot 1 (upper) [A].



#### ↓ Note

- If the customer has used all of the slots, you have to keep an empty slot for this procedure. Ask the customer to temporarily remove the SD card in SD Card Slot 1.

- Check whether the card is properly in the SD Card Slot. When a SD card is inserted, a click is heard, and it is locked.
  - To remove the card, release by pressing once in the set state.
4. Turn ON the main power.
  5. Wait until a firmware name is shown on the display (about 1 minute).

**Note**

- The firmware name is read from inside the firmware. The firmware name is not changed even if you change the file name on your PC.
6. If the necessary firmware name is shown on the display, check the firmware version with the left-arrow or right-arrow keys. Pressing the left or right-arrow key shows a firmware name, firmware version and serial number in order.
  7. To use a different firmware, push the up-arrow key or the down-arrow key to find the necessary firmware.
  8. To select the firmware, push the OK key. Make sure that the selected firmware is highlighted.
  9. If you update more than one firmware program at the same time, find each of them and select each of them. Make sure that the selected firmware is high-lighted.
  10. To start firmware update, push the "UpDate" key. While each firmware is downloaded, the underscores on the operation panel are replaced by stars.
  11. Wait until the message "Update done" is shown.
  12. After turning OFF the main power, remove the SD card.
  13. Again, turn ON the main power, and check whether the machine is operating normally.
  14. Print the Configuration Page to check that the every firmware is correctly updated:  
List/Test Print > Config. Page
  15. Reassemble the machine.

**Note**

- An error code is shown if an error occurs during the download. Error codes have the letter "E" and a number. If an error occurs, the firmware is not correctly downloaded; see the error code table ([Error Screens During Updating](#)) and do the necessary steps. After this, download the firmware again.
- If firmware update is interrupted by power failure, the firmware is not correctly downloaded. In this condition, machine operation is not guaranteed. You have to download the firmware again.

---

## Error Screens During Updating

---

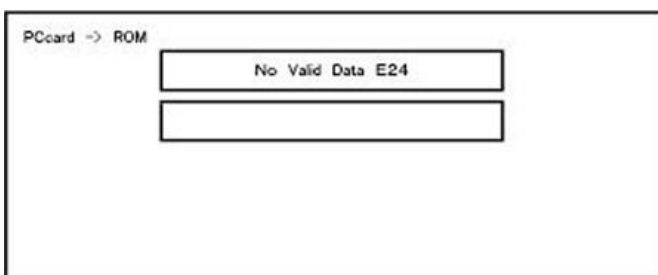

## 5. System Maintenance

EXX shows an error code.

(This error is generated if update was performed when a printer application startup card is removed after system startup. An error indicating failure of card access is displayed on the screen.)

For error codes, refer to the following table:

### Error Code List

Code	Contents	Solutions
20	Physical address mapping cannot be performed.	<ul style="list-style-type: none"> <li>Switch the main power supply off and on to try again.</li> <li>Re-insert the SD card to reboot it.</li> <li>Replace the controller board (PCB3) if the above solutions do not solve the problem.</li> </ul>
21	Insufficient memory for the download	<ul style="list-style-type: none"> <li>Switch the main power supply off and on to try again.</li> <li>Replace the controller board (PCB3) if the updating cannot be done by switching the power off and on.</li> </ul>
23	Error occurred when ROM update program started	Controller program abnormal. If the second attempt fails, replace controller board (PCB3).
22	Decompression of compressed data failed.	<ul style="list-style-type: none"> <li>Switch the main power supply off and on to try again.</li> <li>Replace the SD card used for the update.</li> <li>Replace the controller board (PCB3) if the above solutions do not solve the problem.</li> </ul>
24	SD card access error	<ul style="list-style-type: none"> <li>Re-insert the SD card.</li> <li>Switch the main power supply off and on to try again.</li> <li>Replace the SD card used for the update.</li> <li>Replace the controller board (PCB3) if the above solutions do not solve the problem.</li> </ul>
31	Data incorrect for continuous download	Insert the SD card with the remaining data required for the download, then re-start the procedure.
32	The SD card used after download suspension is incorrect. SD cards are different between the one which was inserted before power interruption and the one which was inserted after power interruption.	<ul style="list-style-type: none"> <li>Insert the SD card containing the same program as when the firmware update was suspended, and then switch the main power supply off and on to try again.</li> <li>There is a possibility that the SD card is damaged if the update cannot be done after the correct SD card has been inserted. In this</li> </ul>

Code	Contents	Solutions
		<p>case, try again with a different SD card.</p> <ul style="list-style-type: none"> <li>Replace the controller board (PCB3) if the above solutions do not solve the problem. Replace all relevant boards if the update is done for the BiCU (PCB2).</li> <li>Replace the operation panel unit if the update is done for the operation panel.</li> </ul>
33	<p>Card version error. The wrong card version is downloaded.</p>	<ul style="list-style-type: none"> <li>Install the correct ROM update data for each version in the SD card.</li> </ul>
34	<p>Destination error. A card for the wrong destination is inserted.</p>	<ul style="list-style-type: none"> <li>Install the correct ROM update data for each destination (JPN/ EXP/ OEM) in the SD card.</li> </ul>
35	<p>Model error. A card for the wrong model is inserted.</p>	<ul style="list-style-type: none"> <li>Install the correct ROM update data for each model in the SD card.</li> </ul>
36	<p>Module error. The program to be downloaded does not exist on the main unit. The download destination specified by the card does not match up to the destination for the main unit's program.</p>	<ul style="list-style-type: none"> <li>Install the program to be updated in advance.</li> <li>There is a possibility that the SD card containing the program to be updated has not been mounted. Check to confirm that the SD card has been correctly mounted.</li> <li>The SD card is incorrect if the program to be updated has been correctly installed. In this case, insert the correct SC card.</li> </ul>
38	<p>The version of the downloaded program has not been authorized for the update.</p>	<ul style="list-style-type: none"> <li>Make sure that the program to be overwritten is the specified version.</li> </ul>
40	<p>Engine download fails.</p>	<ul style="list-style-type: none"> <li>Switch the main power supply off and on to try again.</li> <li>If the download fails again, replace the controller board (PCB3) and the BiCU (PCB2).</li> </ul>
44	<p>The data to be overwritten cannot be accessed when controller-related programs are downloaded.</p>	<ul style="list-style-type: none"> <li>Switch the main power supply off and on to try again.</li> <li>Install the correct ROM update data in the SD card.</li> <li>Replace the controller board (PCB3) if the data to be overwritten is contained on the controller board (PCB3).</li> </ul>
49	<p>Firmware updates are currently prohibited.</p>	<ul style="list-style-type: none"> <li>The setting of Update Firmware in the Administrator Tools has been set to [Prohibit]</li> </ul>

## 5. System Maintenance

Code	Contents	Solutions
		by an administrator. Amend the setting to [Do not Prohibit] and try again.
50	The results of the electronic authorization check have rejected the update data.	<ul style="list-style-type: none"> <li>Install the correct ROM update data in the SD card.</li> </ul>

### ↓ Note

- The PDF firmware installed as standard contains a program required to print PS3 data as default. However, this PS3 program is normally disabled.
- The PS3 firmware is a dongle (key) which enables PS3 data printing functions. When the PS3 firmware is installed, the PS3 program in the PDF firmware is enabled. Due to this specification, the self-diagnosis result report shows the ROM part number/software version of the PDF firmware contained in the PS3 program.

## RFU Updating the Firmware

In this machine, software can be updated by remote control using @Remote.

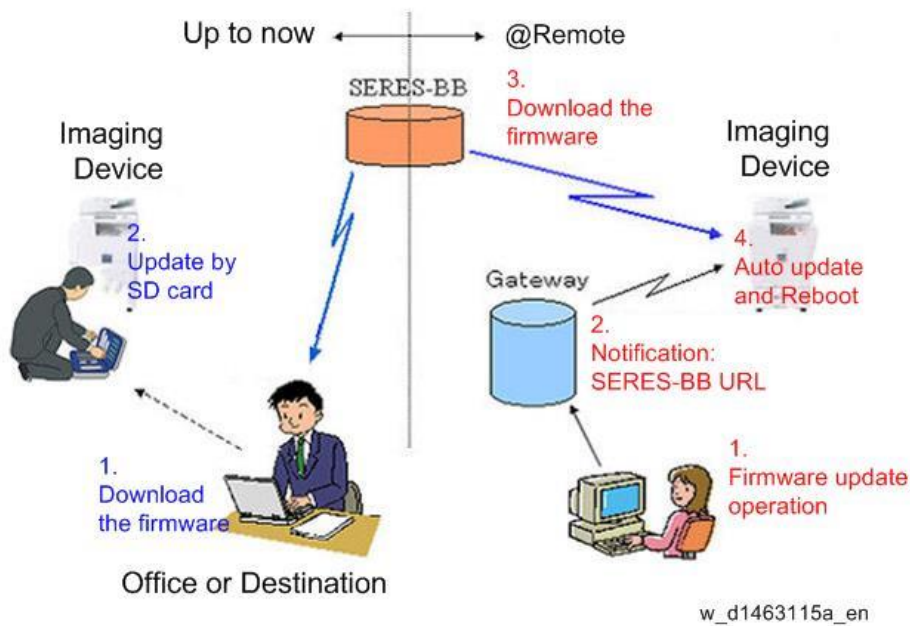

---

### RFU Performable Condition

---

RFU is performable for a device which meets the following conditions.

1. The customer consents to the use of RFU.
2. The device is connected to a network via TCP/IP for @Remote.

## Updating JavaVM

---

### Procedure

---

Updating Java VM is performed with PC using the update tool.

- **Prepare the following items in advance.**
  - SD memory card reader/writer
  - PC
- **Updating flow is as follows.**
  1. Deactivate the SDK applications with Web Image Monitor.
  2. Remove the VM CARD Type P18 from the main machine.
  3. Update Java VM with PC using the update tool.
  4. Install the VM CARD Type P18 to the main machine.
  5. Activate the SDK applications with Web Image Monitor.

### Deactivating SDK Applications

---

- 1.** Log in as the administrator from Web Image Monitor.
- 2.** Take a note of the current heap size setting in [Heap / Stack Size Settings].
  - [Device Management] -> [Configuration] -> [Extended Feature Settings] -> [Administrator Tools] -> [Heap / Stack Size Settings]
- 3.** Stop all SDK applications except for Java TM Platform.
  1. Display the [Startup Setting] menu.
    - [Device Management] -> [Configuration] -> [Extended Feature Settings] -> [Startup Setting]
  2. Check the radio button of the SDK application which status is "Starting Up".
  3. Click [Start Up/Stop] to stop the application.  
"Stop" is displayed in the status column.

#### Note

- Do not change the status of Java TM Platform to "Stop".

- 4.** Make sure that "Auto Start" is set to "Off" for each SDK application.
  1. Click the [Details] icon (📄) for each SDK application in [Startup Setting].
  2. Make sure that "Auto Start" is set to "Off". (Default: On)
- 5.** Turn the main power OFF.

- 6.** Remove VM CARD Type P18 from the SD Card Slot 1 [A].



m0cja0254

### Updating JavaVM

---

- 1.** Insert VM CARD Type P18 into SD memory card reader/writer of your PC.
- 2.** Check that the SD memory card reader/writer is detected on your PC, and then write down the drive letter. (If the SD memory card reader/writer is detected as (F:), the drive letter is "f")
- 3.** Download the update modules from Firmware Download Center.
- 4.** Unzip the downloaded file, and then execute the .exe file.
- 5.** The folder is generated.
- 6.** Execute the .bat file in the folder.
- 7.** Input the drive letter following a message "Please input drive letter of SD card [a - x]: ". (If the SD memory card reader/writer is detected as (F:), input "f")



d255a1520

- 8.** Press the [Enter] key to start updating Java VM.  
It takes 3 minutes to update Java VM.
- 9.** After completing the update, remove VM CARD Type P18 from SD memory card reader/writer of your PC.

## 5. System Maintenance

**10.** Insert VM CARD Type P18 into SD Card Slot 1 [A] of the machine.

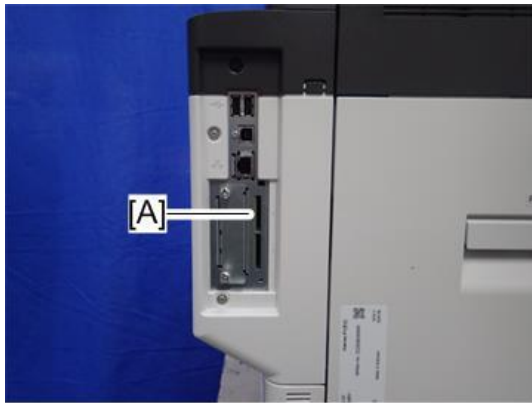

m0cja0254

**11.** Reassemble the machine.

### Activating SDK Applications

---

- 1.** Turn the main power ON.
- 2.** Log in as the administrator from Web Image Monitor.
- 3.** Change the setting of "Auto Start" to "On" for each SDK application.
  1. Display the [Startup Setting] menu.
    - [Device Management] -> [Configuration] -> [Extended Feature Settings] -> [Startup Setting]
  2. Click the [Details] icon (📄) for each SDK application.
  3. Make sure that "Auto Start" is set to "On". (Default: On)
- 4.** Reconfigure the heap size setting in [Heap / Stack Size Settings].
  - [Device Management] -> [Configuration] -> [Extended Feature Settings] -> [Administrator Tools] -> [Heap / Stack Size Settings]

## Capturing the Debug Logs

### Overview

With this feature, you can save debug logs that are stored in the machine (HDD) on an SD card. It allows the service representative to save and retrieve error information for analysis.

The Capturing Log feature saves debug logs for the following two.

- Controller debug log including operation log
- Engine debug log

#### ★ Important

- In older models, a service representative enabled the logging tool after a problem occurred. After that, when the problem had been reproduced, the service representative was able to retrieve the debug log.
- However, this new feature saves the debug logs at the time that problems occur. Then you can copy the logs to an SD card.
- You can retrieve the debug logs using an SD card without a network.
- Analysis of the debug log is effective for problems caused by the software. Analysis of the debug log is not valid for the selection of defective parts or problems caused by hardware.

### Types of debug logs that can be saved

Type	Storage Timing	Destination (maximum storage capacity)
Controller debug log (GW debug log)	<ul style="list-style-type: none"> <li>• Saved at all times</li> </ul>	HDD or SD card connected to the service slot (8 GB) When the data gets over 8.0 GB, the older data is deleted.
Engine debug log	<ul style="list-style-type: none"> <li>• When an engine SC occurs</li> <li>• When paper feeding/output stop by jams</li> <li>• When the machine covers are opened during normal operation</li> </ul>	HDD or SD card connected to the service slot (Up to 300 times)

#### ↓ Note

- Debug logs are not saved in the following conditions.
  - While erasing all memory
  - While data encryption equipment is installed
  - While changing the firmware configuration
  - Forced power OFF (accidentally disconnecting the outlet)
  - Engine debug log in shutdown
  - When the destination is HDD and the power supply to the HDD is off because of energy saving (engine OFF mode /STR mode)

## 5. System Maintenance

- When one of the following SC occurs: SC816, SC819, SC878, SC899, SC860, SC863, or SC864
- Following logs are not saved:
  - Log related to the energy saver mode (Engine-off, suspend-mode, or other cases)  
Network communication log  
Logs related to NRS  
Access log for the unauthorized user (guest)
  - HTTP session timeout log
  - Auto logout log

### Security of the Operation Log

---

The following operation logs related to security are not saved.

- User ID
- Password
- IP address
- Telephone number
- Encryption key
- Transition to SP mode

Also the following operation logs are not saved.

- Soft keyboard on the touch panel display
- External keyboard

### Storing the Device Logs on an SD Card

---

The model without HDD does not have space to store device logs. To store device logs on such a model, insert an SD card into the service slot on the back of the machine.

#### Important

It is recommended to use the SD card (16 GB) provided as a service part. The part number of the SD card that is registered as a service part is "B6455060".

- 1.** Insert the SD card into the service SD card slot (upper slot).
- 2.** Turn the power on.
- 3.** Enter SP mode.
- 4.** Set SP5-858-001 (Save Machine Info) to "1 (ON)".
- 5.** Set SP5-858-002 (Target) to "1 (SD)".
- 6.** Execute SP5-858-003 (Make LogTrace Dir).
- 7.** Power cycle the machine.

After the power is turned on, the machine starts to store the device logs on the SD card.

---

## Retrieving the Debug Logs

---

### ★ Important

- Retrieve debug logs to identify the date of occurrence of the problems and to find details of the problems
- e.g.: At around 8:00 am on March 10, an engine stall occurred. The operation panel does not respond. Turn the main power OFF/ON.
- Analysis of the debug log is effective for problems caused by the software. Analysis of the debug log is not valid for the selection of defective parts or problems caused by hardware.

### Procedure for Retrieving the Debug Log with SD Card

---

#### 1. Insert the SD card into the machine's service slot.

##### ★ Important

- It is recommended to use either the SD card with 2GB (P/N: B6455030) or 8GB (P/N: B6455040) provided as service parts. This is because the log data can be acquired much faster than when using commercially available SD cards.
- Format the SD card by using SD Formatter from Panasonic before copying the logs:  
[https://www.sdcard.org/downloads/formatter\\_4/](https://www.sdcard.org/downloads/formatter_4/)

#### 2. Turn the power on.

#### 3. Enter SP mode.

#### 4. Specify the date that the problem occurred in SP5-858-101 (Start Date) by setting it to the year-month-day calendar format.

- For example, if a problem occurred on February 1, 2015, the date should be set to "20150201", as shown above.
- Be sure to confirm the date when the problem occurred before obtaining the logs.

#### 5. Specify the number of days to collect the logs in SP5-858-102 (Days of Tracing).

- "2" is set by default, which is the minimum needed for investigating the problem.
- A value of "1" to "180" can be set.

#### 6. Execute SP5-858-111 (Acquire All Info & Logs) to copy all of the log types to an SD card.

It is possible to obtain the logs separately by the SPs below.

SP	Collectable Information and/or Logs
SP5-858-111	All of the information and logs that are collected by executing the SPs from SP5-858-121 to SP5-858-146, and SMC.
SP5-858-121	Configuration page
SP5-858-122	Font page
SP5-858-123	Print settings list

## 5. System Maintenance

SP	Collectable Information and/or Logs
SP5-858-124	Error log
SP5-858-141	Controller log, engine log, and SMC.
SP5-858-142	Controller log
SP5-858-143	Engine log
SP5-858-146	Network packets
SP5-992-001	SMC

### Note

- The approximate time it takes to transfer the debug log is as follows. Transfer time may be affected by the type or format of the SD card.  
 Controller log (GW debug log): 2 - 20 minutes  
 Engine log: 2 minutes  
 Operation panel log: 2 - 20 minutes

If the estimated time is not calculated due to an error, an error code will be displayed.

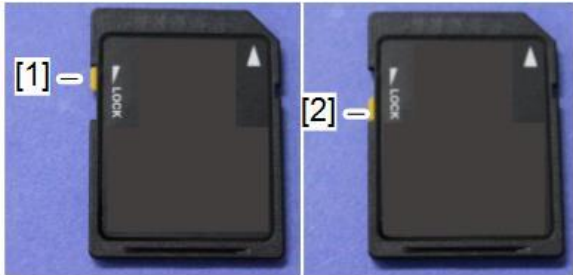
Error code	Description
-1	Other problem.
-2	No SD card is inserted in the service slot or in the SD slot. Insert an SD card to either of the SD slots.
-3	<p>The SD card is locked. Unlock the SD card as shown below.</p>  <p>1. Unlocked 2. Locked</p>

**7.** Wait for the information and/or logs to be copied to the SD card.

**8.** After a message stating that the process has completed appears on the operation panel, make

sure that the LED light next to the SD slot is not flashing. Then, remove the SD card.

**Note**

- The process of obtaining logs fails in the following cases:
  - When the size of the logs to obtain exceeds the amount of space available on the SD card.
  - When the SD card is removed while the logs are being copied to it.
  - When the SD card is not formatted.
- If 'failed' appears on the touch panel display, turn the power off, and then recover from step 1 again.

**Note**

Refer to "[Log File List](#)" to check the location of log files and file name.

### Procedure for Retrieving the Debug Log via Web Image Monitor

---

1. Access the following URL and login as an administrator:

[http://\[IP address or hostname\]/web/entry/df/websys/direct/getSysinfo.cgi](http://[IP address or hostname]/web/entry/df/websys/direct/getSysinfo.cgi)

d259z5002

2. Specify the date that the problem occurred and the number of days to download the logs. Then press [Download].

d259z5003

**Note**

- 2 (days) is set by default. The value can be changed from 1 to 180.

3. The confirmation screen will appear and the information and/or logs will start being downloaded. To

## 5. System Maintenance

proceed to download the information and/or logs, wait for the open-or-save dialog to appear.

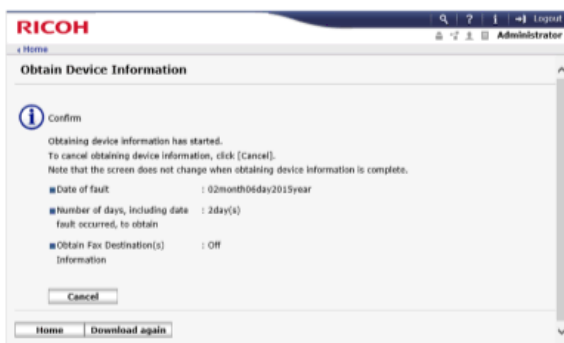

d259z5004

### Note

- To cancel downloading, press [Cancel].
- To reconfigure some settings, press [Download again].

4. After a while, the open-or-save dialog will appear. Specify where to download and save the file.



d259z5006

### Note

Refer to "[Log File List](#)" to check the location of log files and file name.

## Log File List

The logs are saved with the following file path + names.

Controller debug log (mmsg)	/LogTrace/[*the model number]/watching/[yyyymmdd_hhmmss]_[aunique value].gz
Engine debug log	/LogTrace/[*the model number]/engine/[yyyymmdd_hhmmss].gz
SMC	/LogTrace/[*the model number]/smc/[*the model number]_[5992xxx]_[yyyymmdd_hhmmss].csv
Configuration page	/LogTrace/[*the model number]/gps/ConfigurationPage/ConfigurationPage_[yyyymmdd_hhmmss].csv
Font page	<ul style="list-style-type: none"> <li>• /LogTrace/[*the model number]/gps/FontPage/FontPage_PCL_[the page number]_[yyyymmdd_hhmmss].jpg</li> <li>• /LogTrace/[*the model number]/gps/FontPage/FontPage_PDF_[the page number]_[yyyymmdd_hhmmss].jpg</li> <li>• /LogTrace/[*the model number]/gps/FontPage/FontPage_PS_[the page number]_[yyyymmdd_hhmmss].jpg</li> </ul>
Print setting	<ul style="list-style-type: none"> <li>• /LogTrace/[*the model</li> </ul>

## 5. System Maintenance

list	number]/gps/PrintSettingList/PrintSettingList_RPGL_[yyyymmdd_hhmmss].txt • /LogTrace/[*the model number]/gps/PrintSettingList/PrintSettingList_RTIFFF_[yyyymmdd_hhmmss].csv
Error log	/LogTrace/[*the model number]/gps/ErrorLog/[yyyymmdd_hhmmss].csv

## NVRAM Data Upload/Download

---

### Uploading Content of NVRAM to an SD card

---

Do the following procedure to upload SP code settings from NVRAM to an SD card.

**Note**

- This data should always be uploaded to an SD card before the NVRAM is replaced.
- Make sure that the write protection of an SD card is unlocked.

- 1.** Execute SP5-990-001 (SP Print Mode: All (Data List)) before you turn OFF the main power. You will need a record of the NVRAM settings if the upload fails.
- 2.** Turn OFF the main power.
- 3.** Insert the SD card into SD Card Slot 1 (upper) [A].



m0cja0254

- 4.** Turn ON the main power.
- 5.** Press [Execute] in SP5-824-001 (NVRAM Data Upload).
- 6.** The following files are copied to an NVRAM folder on the SD card when the upload procedure is finished. The file is saved to the path and the following filename:  
**NVRAM\<serial number>.NV**  
Here is an example with Serial Number "K5000017114":  
NVRAM\K5000017114.NV
- 7.** In order to prevent an error during the download, be sure to mark the SD card that holds the uploaded data with the number of the machine from which the data was uploaded.

**Note**

- You can upload NVRAM data from more than one machine to the same SD card.

---

### Downloading an SD Card to NVRAM

---

Do the following procedure to download SP data from an SD card to the NVRAM in the machine.

- The NVRAM data download may fail if the SD card with the NVRAM data is damaged, or if the connection between the controller and BiCU (PCB2) is defective.
- Do the download procedure again if the download fails.
- Do the following procedure if the second attempt fails:

- Enter the NVRAM data manually using the SMC print you created before uploading the NVRAM data.
- 1.** Turn OFF the main power.
  - 2.** Insert the SD card into SD Card Slot 1 (upper) [A].

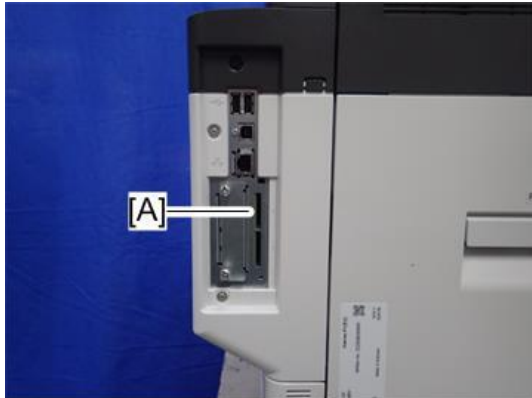

m0cja0254

- 3.** Turn ON the main power.
- 4.** Press [Execute] with SP5-825-001 (NVRAM Data Download).

**Note**

- The serial number of the file on the SD card must match the serial number of the machine for the NVRAM data to download successfully. The download fails if the serial numbers do not match.

This procedure does not download the following data to the NVRAM:

- Total Count

## SMC List Card Save Function

### Overview

#### SMC List Card Save

The SMC List Card Save (SP Text Mode) function is used to save the SMC list as CSV files to the SD-card inserted into the SD card slot.

### Procedure

- 1.** Turn OFF the main power.
- 2.** Insert the SD card into the SD Card Slot 1 (upper). Then turn ON the main power.
- 3.** Enter the [Engine] in the SP mode (Service).
- 4.** Select SP5-992 (SP Text Mode).
- 5.** Select a detail SP number shown below to save data on the SD card and press [OK].

SP5-992-xxx (SP Text Mode)

Detail No.	SMC Categories to Save
001	All (Data List)
002	SP (Mode Data List)
004	Logging Data
005	Diagnostic Report
006	Non-Default
007	NIB Summary
024	SDK/J Summary
025	SDK/J Application Info
026	Printer SP

- 6.** Press [EXECUTE].

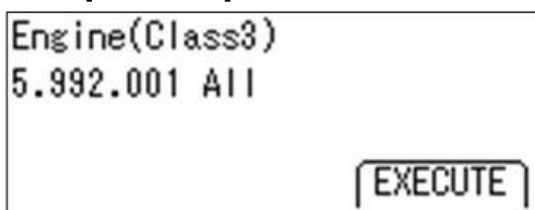

m257z0027

- 7.** Press [EXECUTE] again to start. Press [CANCEL] to cancel the download.

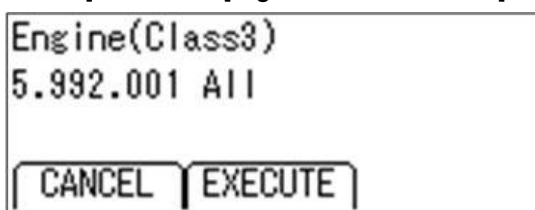

m257z0028

8. Wait for 2 to 3 minutes until "Completed" is shown.

**Note**

- The SMC list saving may take from 2 to 3 minutes to complete.
- Press [CANCEL] to abort executing.

9. Press [End] to exit from SP mode.

---

## File Names of the Saved SMC Lists

---

The SMC list data saved on the SD-card will be named automatically. The file naming rules are as follows.

Example:

W801P999017\_59921\_20111011\_53954.csv

[A]	[B]	[C]	[D]	[E]

d1440131a

**A:**

**Machine serial number (fixed for each machine)**

**B:**

**SP number saved in this file.**

First four digits (5992) in this part are fixed. The other one or two digits are the detail SP number(s). In this case, it is one digit. Therefore, this file is of SP5-992-001 (All data list). See the upper SP table for the correspondence between SP detail numbers and the contents.

**C:**

**File creation date**

Year/Month/Day ("Zero" will be omitted if each is one digit.)

**D:**

**File creation time**

Hour/Minute/Second ("Zero" will be omitted if each is one digit.)

**E:**

**File Extension CSV (Comma Separated Value)**

This part is fixed.

**Note**

- A folder named by the machine serial number will be created on the SD card when this function is executed.

---

## Error Messages

---

SMC List Card Save error message:

## 5. System Maintenance

- **Failed:**

FACTOR: Read-only file system, No space left on device.

If an error occurs, pressing [Exit] will cause the device to discard the job and return to the ready state.

## Test Pattern Printing

Printing Test pattern: SP2-109

Some of these test patterns are used for copy image adjustments but most are used primarily for design testing.

### Note

- Do not operate the machine until the test pattern is printed out completely. Otherwise, SC will occur.

---

### Procedure

---

- Enter the SP mode and select SP2-109-003 (Test Pattern).
- Enter the number for the test pattern that you want to print -> Press [OK].

SP2-109-003 (Test Pattern)

No.	Pattern	No.	Pattern
0	None	13	Independent Pattern (4dot)
1	Vertical Line (1 dot)	14	Trimming Area
2	Vertical Line (2 dot)	15	Hound's Tooth Check (Vertical)
3	Horizontal Line (1 dot)	16	Hound's Tooth Check (Horizontal)
4	Horizontal Line (2 dot)	17	Black Band (Horizontal)
5	Grid Vertical Line	18	Black Band (Vertical)
6	Grid Horizontal Line	19	Checker Flag Pattern
7	Grid Pattern Small	20	Grayscale (Vertical)
8	Grid Pattern Large	21	Grayscale (Horizontal)
9	Argyle Pattern Small	22	Wormy Pattern
10	Argyle Pattern Large	23	Full Dot Pattern
11	Independent Pattern (1dot)	24	All White Pattern
12	Independent Pattern (2dot)		

- Select SP2-109-005 (1: Full Color, 2: Black, 3: Magenta, 4:Cyan, 5: Yellow) to select the printing color.
- To change the density of test pattern, select density with SP2-109-006 to 009 for each color.

### Note

- If select "0" with SP2-109-006 through 009, the color adjusted so will not show up in the test pattern.

- Enter SP2-109-010 (Side Select), SP2-109-011 (1 Sheet Printing) or SP2-109-012 (Continue Printing), and then press "Execute" to print test pattern.
- Check the test pattern.
- Exit SP mode.

## 6. Troubleshooting

### Self-Diagnostic Mode

#### Service Call Codes

#### Service Call Conditions

Pattern	Display	How to reset	SC call or SC alarm in customer support system
A	The SC is displayed on the operation panel, and the machine cannot be used (safety-related SC).	Execute CE reset SP mode, and switch main power from OFF to ON.	Occurrence & alarm count ↓ Immediate alarm
B	When a function is selected, the SC is displayed on the operation panel, and the machine cannot be used (down-time mitigation).	Switch main power from OFF to ON.	Occurrence & alarm count ↓ Power OFF and ON ↓ Alarm count and alarm only if recurrence
C	No display on the operation panel, and use is permitted.	Count only logging.	Occurrence ↓ Logging count & alarm count
D	The SC is displayed on the operation panel, and the machine cannot be used (machine-error SC).	Switch main power from OFF to ON.	Occurrence & alarm count ↓ Power OFF and ON ↓ Alarm count and alarm only if recurrence

#### ↓ Note

- When an ordinary SC (type D) is generated, an automatic reboot is performed. When an event is reported by the customer support system, even in the event of an ordinary SC, reboot is not performed. During automatic reboot, a confirmation screen is displayed after the reboot.

- When automatic reboot occurs twice continuously, an SC is displayed without rebooting, and logging count is performed. Also, when an SMC print is output, an \* mark is added alongside the SC number for clarity.
- Automatic reboot can be enabled or disabled with SP5-875-001 (SC automatic reboot setting) (default value: ON).

---

## SC Logging

---

When an SC is generated, the "total count value when the SC is generated" and the "SC code" are logged. However, if the total count value during the SC is the same as last time, logging is not performed.

Logged data can be checked by outputting an administrative report (SMC print). The SC history is logged up to the last 10 entries, and if there are more than 10 entries, data are progressively deleted starting from the oldest.

---

## SC Automatic Reboot

---

When an ordinary SC (type D) is generated, automatically reboot is performed. Automatic reboot or reboot by user operation can be set by SP5-875-001 (SC automatic reboot setting out) (default value: 1 "OFF").

When a type D occurs, an automatic reboot is done or the machine display asks the customer if it can reboot. However, when the SC occurs twice in a short time, the machine sends a report to the @Remote server without rebooting. This is because just rebooting may not be a good solution if an SC occurs twice.

When an automatic reboot is performed, a confirmation screen is displayed after reboot. The confirmation screen can be canceled by pressing the [OK] key (display is not canceled only when the main power switch is switched OFF to ON).

### Screen display during reboot

- Status display on the current screen
    - Post-processing ..... Post-processing during printing, etc.
    - Automatic reboot .... After operation end
- Post-processing  
 ■ ■ □ □ □ □ □ □ □ □
- Until automatic reboot  
 □ □ □ □ □ □ □ □ □ □
- [Reboot] key  
Key to perform the reboot
  - Turn ON spanner LED (same as when an SC is generated).

## 6.Troubleshooting

### Operation during SC reboot

- Timing of SC reboot

When @Remote is enabled, and when a NRS alarm\*1 is not generated, the corresponding SC is the object of an automatic reboot.

\*1 NRS alarm: Issued when an ordinary SC (type D) is generated twice while the total counter counts 10 times.

- Time to automatic reboot

Reboot is performed 30 seconds after an engine reboot is possible, after the end of post-processing during printing, etc.

At that time, a reboot is performed even if the MFP is operating. The engine does not start process control when a reboot is possible.

- Automatic reboot

See the flowchart below.

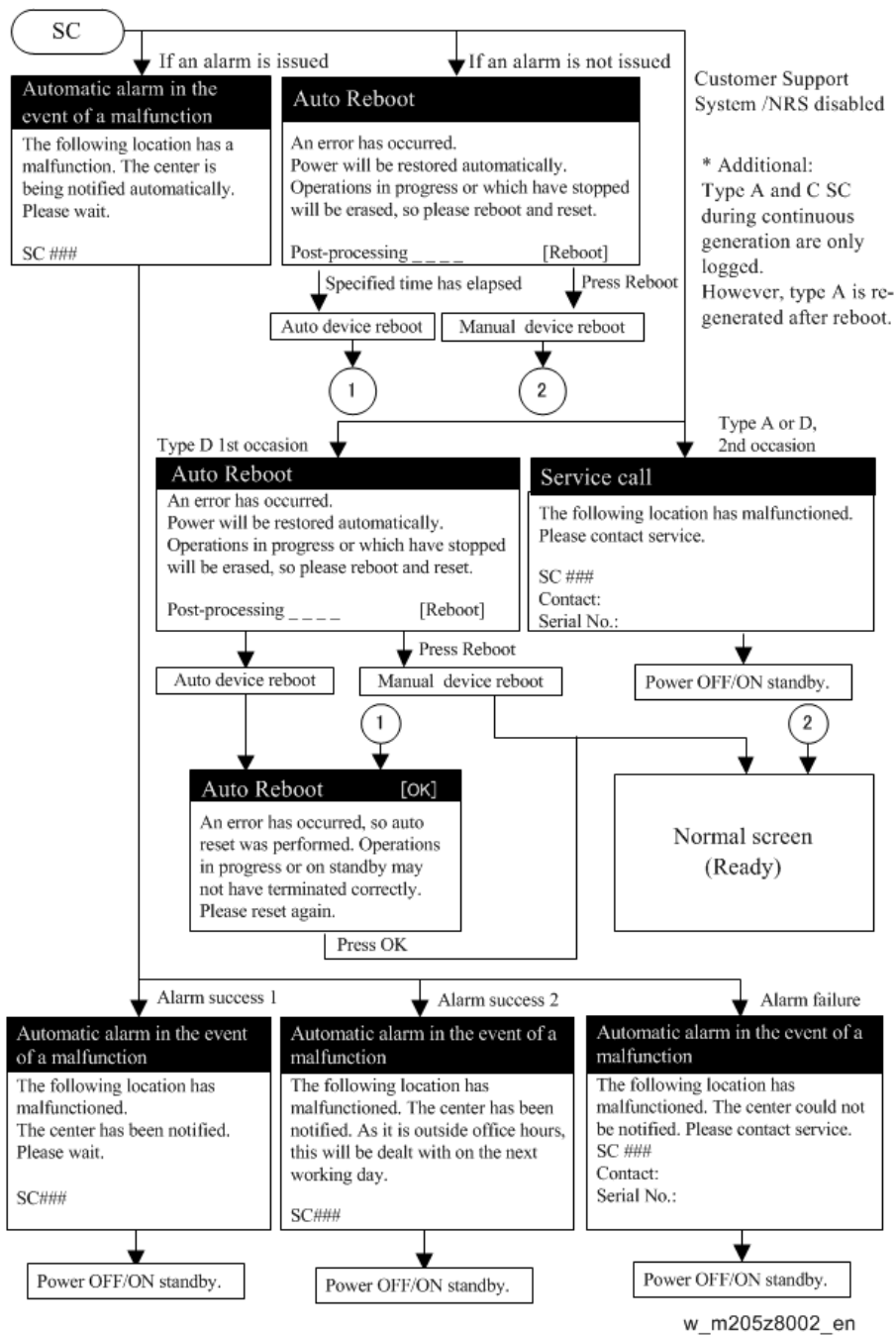

## Service Call 195

---

### SC100 (Engine: Others)

---

SC No.	Type	Error Name/Error Condition/Major Cause/Solution
SC195-00	D	Machine serial number error
		Comparison of the product identification code in the machine serial number (11 digits).
		The product identification code in the machine serial number (11 digits) does not match.
		Re-enter the machine serial number.

## Service Call 202-271

### SC200 (Engine: Image Writing)

SC No.	Type	Error Name/Error Condition/Major Cause/Solution
SC202-01	D	Polygon Motor (M1) Error at Machine Startup (Black/Magenta)
		The steady signal of the motor does not turn on after passing 6s since the polygon motor starts up.
		<ul style="list-style-type: none"> <li>• The connector is not properly connected or the wire is faulty.</li> <li>• The Laser unit defective is faulty.</li> <li>• The firmware is faulty.</li> <li>• The main/engine PCB (PCB1) is faulty.</li> </ul>
		<ol style="list-style-type: none"> <li>1. Clean the terminal of the following wire connectors and reconnect the connectors. If there is no continuity, replace the wire. Laser unit (KM) - Main/engine PCB (PCB1)</li> <li>2. Replace the laser unit (KM).</li> <li>3. Upgrade the engine firmware to the latest version.</li> <li>4. Replace the main/engine PCB (PCB1).</li> </ol>

SC No.	Type	Error Name/Error Condition/Major Cause/Solution
SC202-02	D	Polygon Motor (M1) Error during Operation (Black/Magenta)
		The steady signal of the motor turns off for 6s in succession after the polygon motor was stabilized.
		<ul style="list-style-type: none"> <li>• The connector is not properly connected or the wire is faulty.</li> <li>• The Laser unit defective is faulty.</li> <li>• The firmware is faulty.</li> <li>• The main/engine PCB (PCB1) is faulty.</li> </ul>
		<ol style="list-style-type: none"> <li>1. Clean the terminal of the following wire connectors and reconnect the connectors. If there is no continuity, replace the wire. Laser unit (KM) - Main/engine PCB (PCB1)</li> <li>2. Replace the laser unit (KM).</li> <li>3. Upgrade the engine firmware to the latest version.</li> <li>4. Replace the main/engine PCB (PCB1).</li> </ol>

SC No.	Type	Error Name/Error Condition/Major Cause/Solution
SC203-01	D	Polygon Motor (M1) Error at Machine Startup (Cyan/Yellow)
		The steady signal of the motor does not turn on after passing 6s since the polygon motor starts up.
		<ul style="list-style-type: none"> <li>• The connector is not properly connected or the wire is faulty.</li> </ul>

## 6.Troubleshooting

SC No.	Type	Error Name/Error Condition/Major Cause/Solution
		<ul style="list-style-type: none"> <li>The Laser unit defective is faulty.</li> <li>The firmware is faulty.</li> <li>The main/engine PCB (PCB1) is faulty.</li> </ul>
		<ol style="list-style-type: none"> <li>Clean the terminal of the following wire connectors and reconnect the connectors. If there is no continuity, replace the wire. Laser unit (CY) - Main/engine PCB (PCB1)</li> <li>Replace the laser unit (CY).</li> <li>Upgrade the engine firmware to the latest version.</li> <li>Replace the main/engine PCB (PCB1).</li> </ol>

SC No.	Type	Error Name/Error Condition/Major Cause/Solution
SC203-02	D	Polygon Motor (M1) Error during Operation (Cyan/Yellow)
		The steady signal of the motor turns off for 6s in succession after the polygon motor was stabilized.
		<ul style="list-style-type: none"> <li>The connector is not properly connected or the wire is faulty.</li> <li>The Laser unit defective is faulty.</li> <li>The firmware is faulty.</li> <li>The main/engine PCB (PCB1) is faulty.</li> </ul>
		<ol style="list-style-type: none"> <li>Clean the terminal of the following wire connectors and reconnect the connectors. If there is no continuity, replace the wire. Laser unit (CY) - Main/engine PCB (PCB1)</li> <li>Replace the laser unit (CY).</li> <li>Upgrade the engine firmware to the latest version.</li> <li>Replace the main/engine PCB (PCB1).</li> </ol>

SC No.	Type	Error Name/Error Condition/Major Cause/Solution
SC220-01	D	Leading Edge: LD synchronization detection error (01: Bk, 02: C, 03: M, 04: Y)
SC220-02		The leading edge LD synchronization detection signal was not output within the specified time (sec.).
SC220-03		Error detection timing; During the startup operation of the machine or during printing.
SC220-04		<ul style="list-style-type: none"> <li>Laser unit defective (Synchronization optical system defective, LDB (PCB12/PCB14/PCB16/PCB18) defective, LD defective)</li> <li>BiCU (PCB2) defective (Image writing ASIC defective)</li> <li>LDB (PCB12/PCB14/PCB16/PCB18) – BiCU (PCB2) harness broken, or connector disconnected</li> </ul>
		<ol style="list-style-type: none"> <li>Turn the main power OFF/ON.</li> </ol>

SC No.	Type	Error Name/Error Condition/Major Cause/Solution
		2. Check for condensation on the mirrors and lenses. 3. Reconnect the connectors between LDB (PCB12/PCB14/PCB16/PCB18) and BiCU (PCB2). 4. Replace the laser unit. 5. Replace the BiCU (PCB2). 6. Replace the harness between LDB (PCB12/PCB14/PCB16/PCB18) and BiCU (PCB2).

SC No.	Type	Error Name/Error Condition/Major Cause/Solution
SC230-01	D	FGATE*1: Does not turn ON.(01: Bk, 02: C, 03: M, 04: Y)
SC230-02		FGATE signal was not output even though it is time to start writing.
SC230-03		Error detection timing; During printing.
SC230-04		<ul style="list-style-type: none"> <li>• The BiCU (PCB2) and the controller board (PCB3) are not properly connected.</li> <li>• BiCU (PCB2) defective (Image writing ASIC defective)</li> </ul>
		<ul style="list-style-type: none"> <li>• Turn the power OFF and then ON.</li> <li>• Check the connection between the BiCU (PCB2) and the controller board (PCB3).</li> <li>• Replace the BiCU (PCB2).</li> </ul>

(\*1)FGATE: Signals used between the controller and the engine in order to send the information about the sub scan length of the page to be printed.

SC No.	Type	Error Name/Error Condition/Major Cause/Solution
SC230-11	D	FGATE*1: Does not turn ON: Image Transfer Error (11: Bk, 12: C, 13: M, 14: Y)
SC230-12		FGATE signal was not output even though it is time to start writing.
SC230-13		Error detection timing; During printing.
SC230-14		<ul style="list-style-type: none"> <li>• The BiCU (PCB2) and the controller board (PCB3) are not properly connected.</li> <li>• BiCU (PCB2) defective (Image writing ASIC defective)</li> </ul>
		<ul style="list-style-type: none"> <li>• Turn the power OFF and then ON.</li> <li>• Check the connection between the BiCU (PCB2) and the controller board (PCB3).</li> <li>• Replace the BiCU (PCB2).</li> </ul>

(\*1)FGATE: Signals used between the controller and the engine in order to send the information about the sub scan length of the page to be printed.

## 6.Troubleshooting

SC NO.	Type	Error Name/Error Condition/Major Cause/Solution
SC231-01	D	FGATE*1: Does not turn OFF.(01: Bk, 02: C, 03: M, 04: Y)
SC231-02		FGATE signal does not turn off even though it is time to stop writing.
SC231-03		Error detection timing; During printing.
SC231-04		<ul style="list-style-type: none"> <li>• The BiCU (PCB2) and the controller board (PCB3) are not properly connected.</li> <li>• BiCU (PCB2) defective (Image writing ASIC defective)</li> <li>• Turn the power OFF and then ON.</li> <li>• Check the connection between the BiCU (PCB2) and the controller board (PCB3).</li> <li>• Replace the BiCU (PCB2).</li> </ul>

(\*1)FGATE: Signals used between the controller and the engine in order to send the information about the sub scan length of the page to be printed.

SC NO.	Type	Error Name/Error Condition/Major Cause/Solution
SC240-01	D	LD Error (01: Bk, 02: C, 03: M, 04: Y)
SC240-02		LD driver initialization process was not completed properly.
SC240-03		Error detection timing; During machine startup.
SC240-04		<ul style="list-style-type: none"> <li>• LDB (PCB12/PCB14/PCB16/PCB18) harnesses are not properly connected.</li> <li>• LD degradation</li> <li>• LDB (PCB12/PCB14/PCB16/PCB18) defective</li> <li>• LDB (PCB12/PCB14/PCB16/PCB18) harnesses defective</li> <li>• Turn the power OFF and then ON.</li> <li>• Check the connection between the LDB (PCB12/PCB14/PCB16/PCB18) and the BiCU (PCB2).</li> <li>• Replace the laser unit.</li> <li>• Replace the harness between the LDB (PCB12/PCB14/PCB16/PCB18) and the BiCU (PCB2).</li> </ul>

SC No.	Type	Error Name/Error Condition/Major Cause/Solution
SC260-01	C	Laser unit thermistor KM (TH3) error
		The sensor input sampling exceeds the reference value. (After detection, controlled at 25 °C / 77.0 °F)
		<ul style="list-style-type: none"> <li>• The connector is not properly connected or the wire is faulty.</li> <li>• The laser unit is faulty.</li> <li>• The firmware is not the latest version.</li> <li>• The main/engine PCB (PCB1) is faulty.</li> </ul>
		1. Clean the terminal of the following wire connectors and reconnect the

SC No.	Type	Error Name/Error Condition/Major Cause/Solution
		<p>connectors. If there is no continuity, replace the wire.</p> <p>Laser unit (KM) - Main/engine PCB (PCB1)</p> <ol style="list-style-type: none"> <li>Replace the laser unit (KM).</li> <li>Upgrade the engine firmware to the latest version.</li> <li>Replace the main/engine PCB (PCB1).</li> </ol>

SC No.	Type	Error Name/Error Condition/Major Cause/Solution
SC260-02	C	<p>Laser unit thermistor CY (TH4) error</p> <p>The sensor input sampling exceeds the reference value. (After detection, controlled at 25 °C / 77.0 °F)</p> <ul style="list-style-type: none"> <li>The connector is not properly connected or the wire is faulty.</li> <li>The laser unit is faulty.</li> <li>The firmware is not the latest version.</li> <li>The main/engine PCB (PCB1) is faulty.</li> </ul> <ol style="list-style-type: none"> <li>Clean the terminal of the following wire connectors and reconnect the connectors. If there is no continuity, replace the wire. Laser unit (CY) - Main/engine PCB (PCB1)</li> <li>Replace the laser unit (CY).</li> <li>Upgrade the engine firmware to the latest version.</li> <li>Replace the main/engine PCB (PCB1).</li> </ol>

SC No.	Type	Error Name/Error Condition/Major Cause/Solution
SC271-00	D	<p>Laser unit cleaning motor (M10) error</p> <p>Excess current was detected for 5 seconds continuously during the laser unit cleaning motor (M10) operation.</p> <ul style="list-style-type: none"> <li>The laser unit cleaning drive gear or the cleaning spiral does not smoothly rotate due to the load.</li> <li>The laser unit cleaning drive gear or the cleaning spiral is deformed or there is a fault in them.</li> <li>The connector is not properly connected or the wire is faulty.</li> <li>The laser unit cleaning motor (M10) is not properly attached, or it is faulty.</li> <li>The firmware is not the latest version.</li> <li>The main/engine PCB (PCB1) is faulty.</li> </ul> <ol style="list-style-type: none"> <li>Execute laser scanner cleaning.</li> <li>Clean the laser unit cleaning drive gear and the cleaning spiral, and then apply grease to these parts.</li> <li>Replace the laser unit.</li> </ol>

## 6.Troubleshooting

SC No.	Type	Error Name/Error Condition/Major Cause/Solution
		<ol style="list-style-type: none"><li data-bbox="395 248 1321 376">4. Clean the terminal of the following wire connectors and reconnect the connectors. If there is no continuity, replace the wire. Laser unit cleaning motor (M10) - Engine relay PCB (PCB21)</li><li data-bbox="395 394 1390 427">5. Reattach the laser unit cleaning motor (M10). If it is not repaired, replace it.</li><li data-bbox="395 445 1078 479">6. Upgrade the engine firmware to the latest version.</li><li data-bbox="395 497 943 530">7. Replace the main/engine PCB (PCB1).</li></ol>

## Service Call 302-398

### SC300 (Engine: Imaging 2: Around the Drum)

SC No.	Type	Error Name/Error Condition/Major Cause/Solution
SC302-01	D	Charge current error (black)
		The rush-in current to drum unit K is less at the Vpp adjustment for the main charge adjustment.
		<ul style="list-style-type: none"> <li>• The drum or drum screw does not rotate normally.</li> <li>• The main charger unit is not attached properly.</li> <li>• FFC is not properly connected, or it is faulty.</li> <li>• The HVP (PCB19) is faulty.</li> <li>• The firmware is not the latest version.</li> <li>• The main/engine PCB (PCB1) is faulty.</li> </ul>
		<ol style="list-style-type: none"> <li>1. Replace the drum unit.</li> <li>2. Reinstall the main charger unit on the drum unit properly. If it is not resolved, replace the main charger unit.</li> <li>3. Clean the following FFC terminal of the FFC and reconnect. If the FFC terminal is deformed or FFC is short circuited, replace FFC. HVP (PCB19) - main/engine PCB (PCB1)</li> <li>4. Replace the HVP (PCB19).</li> <li>5. Upgrade the main firmware and the engine firmware to the latest version.</li> <li>6. Replace the main/engine PCB (PCB1).</li> </ol>

SC No.	Type	Error Name/Error Condition/Major Cause/Solution
SC302-02	D	Charge current error (cyan)
		The rush-in current to drum unit C is less at the Vpp adjustment for the main charge adjustment.
		<ul style="list-style-type: none"> <li>• The drum or drum screw does not rotate normally.</li> <li>• The main charger unit is not attached properly.</li> <li>• FFC is not properly connected, or it is faulty.</li> <li>• The HVP (PCB19) is faulty.</li> <li>• The firmware is not the latest version.</li> <li>• The main/engine PCB (PCB1) is faulty.</li> </ul>
		<ol style="list-style-type: none"> <li>1. Replace the drum unit.</li> <li>2. Reinstall the main charger unit on the drum unit properly. If it is not resolved, replace the main charger unit.</li> <li>3. Clean the following FFC terminal of the FFC and reconnect. If the FFC terminal is deformed or FFC is short circuited, replace FFC.</li> </ol>

## 6.Troubleshooting

SC No.	Type	Error Name/Error Condition/Major Cause/Solution
		<p>HVP (PCB19) - main/engine PCB (PCB1)</p> <ol style="list-style-type: none"> <li>4. Replace the HVP (PCB19).</li> <li>5. Upgrade the main firmware and the engine firmware to the latest version.</li> <li>6. Replace the main/engine PCB (PCB1).</li> </ol>

SC No.	Type	Error Name/Error Condition/Major Cause/Solution
SC302-03	D	Charge current error (magenta)
		The rush-in current to drum unit M is less at the Vpp adjustment for the main charge adjustment.
		<ul style="list-style-type: none"> <li>• The drum or drum screw does not rotate normally.</li> <li>• The main charger unit is not attached properly.</li> <li>• FFC is not properly connected, or it is faulty.</li> <li>• The HVP (PCB19) is faulty.</li> <li>• The firmware is not the latest version.</li> <li>• The main/engine PCB (PCB1) is faulty.</li> </ul>
		<ol style="list-style-type: none"> <li>1. Replace the drum unit.</li> <li>2. Reinstall the main charger unit on the drum unit properly. If it is not resolved, replace the main charger unit.</li> <li>3. Clean the following FFC terminal of the FFC and reconnect. If the FFC terminal is deformed or FFC is short circuited, replace FFC.</li> </ol> <p>HVP (PCB19) - main/engine PCB (PCB1)</p> <ol style="list-style-type: none"> <li>4. Replace the HVP (PCB19).</li> <li>5. Upgrade the main firmware and the engine firmware to the latest version.</li> <li>6. Replace the main/engine PCB (PCB1).</li> </ol>

SC No.	Type	Error Name/Error Condition/Major Cause/Solution
SC302-04	D	Charge current error (yellow)
		The rush-in current to drum unit Y is less at the Vpp adjustment for the main charge adjustment.
		<ul style="list-style-type: none"> <li>• The drum or drum screw does not rotate normally.</li> <li>• The main charger unit is not attached properly.</li> <li>• FFC is not properly connected, or it is faulty.</li> <li>• The HVP (PCB19) is faulty.</li> <li>• The firmware is not the latest version.</li> <li>• The main/engine PCB (PCB1) is faulty.</li> </ul>
		<ol style="list-style-type: none"> <li>1. Replace the drum unit.</li> <li>2. Reinstall the main charger unit on the drum unit properly. If it is not resolved,</li> </ol>

SC No.	Type	Error Name/Error Condition/Major Cause/Solution
		<p>replace the main charger unit.</p> <p>3. Clean the following FFC terminal of the FFC and reconnect. If the FFC terminal is deformed or FFC is short circuited, replace FFC. HVP (PCB19) - main/engine PCB (PCB1)</p> <p>4. Replace the HVP (PCB19).</p> <p>5. Upgrade the main firmware and the engine firmware to the latest version.</p> <p>6. Replace the main/engine PCB (PCB1).</p>

SC No.	Type	Error Name/Error Condition/Major Cause/Solution
SC321-01	D	Development unit type mismatch (black)
		The main unit and developer unit K is not matched.
		The correct development unit is not installed in the slot for development unit.
		Install the correct development unit.

SC No.	Type	Error Name/Error Condition/Major Cause/Solution
SC321-02	D	Development unit type mismatch (cyan)
		The main unit and developer unit C is not matched.
		The correct development unit is not installed in the slot for development unit.
		Install the correct development unit.

SC No.	Type	Error Name/Error Condition/Major Cause/Solution
SC321-03	D	Development unit type mismatch (magenta)
		The main unit and developer unit M is not matched.
		The correct development unit is not installed in the slot for development unit.
		Install the correct development unit.

SC No.	Type	Error Name/Error Condition/Major Cause/Solution
SC321-04	D	Development unit type mismatch (yellow)
		The main unit and developer unit Y is not matched.
		The correct development unit is not installed in the slot for development unit.
		Install the correct development unit.

SC No.	Type	Error Name/Error Condition/Major Cause/Solution
SC332-01	D	Toner motor (M11) error (black)
		The excess current signal was detected for 5 seconds continuously.
		<ul style="list-style-type: none"> <li>• The spiral locks up. (It does not rotate.)</li> <li>• The drive gear or the coupling do not properly rotate or the excessive load is</li> </ul>

## 6.Troubleshooting

SC No.	Type	Error Name/Error Condition/Major Cause/Solution
		<p>applied to them.</p> <ul style="list-style-type: none"> <li>• The connector or FFC is not connected properly. Or, the wire or FFC is faulty.</li> <li>• Toner motor (M11) (black) is not properly attached, or it is faulty</li> <li>• The toner motor unit is faulty.</li> <li>• The engine relay PCB (PCB21) is faulty.</li> <li>• The firmware is not the latest version.</li> <li>• The main/engine PCB (PCB1) is faulty.</li> </ul>
		<ol style="list-style-type: none"> <li>1. Replace the toner cartridge (K).</li> <li>2. Clean the drive gears and the couplings in the toner motor unit and apply the grease to them.</li> <li>3. Reconnect the following wire connectors and clean FFC and reconnect. If there is no continuity, replace the wire. If the FFC terminal section is deformed or FFC is broken, replace the FFC. <ul style="list-style-type: none"> <li>• Toner motor (M11) (black) and engine relay PCB (PCB21)</li> <li>• Engine relay PCB (PCB21) and main/engine PCB (PCB1)</li> </ul> </li> <li>4. Reattach toner motor (M11) (black). If it is not repaired, replace it.</li> <li>5. Replace the toner motor unit.</li> <li>6. Replace the engine relay PCB (PCB21).</li> <li>7. Upgrade the engine firmware to the latest version.</li> <li>8. Replace the main/engine PCB (PCB1).</li> </ol>

SC No.	Type	Error Name/Error Condition/Major Cause/Solution
SC332-02	D	Toner motor (M11) error (cyan)
		The excess current signal was detected for 5 seconds continuously.
		<ul style="list-style-type: none"> <li>• The spiral locks up. (It does not rotate.)</li> <li>• The drive gear or the coupling do not properly rotate or the excessive load is applied to them.</li> <li>• The connector or FFC is not connected properly. Or, the wire or FFC is faulty.</li> <li>• Toner motor (M11) (cyan) is not properly attached, or it is faulty</li> <li>• The toner motor unit is faulty.</li> <li>• The engine relay PCB (PCB21) is faulty.</li> <li>• The firmware is not the latest version.</li> <li>• The main/engine PCB (PCB1) is faulty.</li> </ul>
		<ol style="list-style-type: none"> <li>1. Replace the toner cartridge (C).</li> <li>2. Clean the drive gears and the couplings in the toner motor unit and apply the grease to them.</li> <li>3. Reconnect the following wire connectors and clean FFC and reconnect. If there is no continuity, replace the wire. If the FFC terminal section is deformed</li> </ol>

SC No.	Type	Error Name/Error Condition/Major Cause/Solution
		<p>or FFC is broken, replace the FFC.</p> <ul style="list-style-type: none"> <li>• Toner motor (M11) (cyan) and engine relay PCB (PCB21)</li> <li>• Engine relay PCB (PCB21) and main/engine PCB (PCB1)</li> </ul> <p>4. Reattach toner motor (M11) (cyan). If it is not repaired, replace it.</p> <p>5. Replace the toner motor unit.</p> <p>6. Replace the engine relay PCB (PCB21).</p> <p>7. Upgrade the engine firmware to the latest version.</p>

SC No.	Type	Error Name/Error Condition/Major Cause/Solution
SC332-03	D	Toner motor (M11) error (magenta)
		The excess current signal was detected for 5 seconds continuously.
		<ul style="list-style-type: none"> <li>• The spiral locks up. (It does not rotate.)</li> <li>• The drive gear or the coupling do not properly rotate or the excessive load is applied to them.</li> <li>• The connector or FFC is not connected properly. Or, the wire or FFC is faulty.</li> <li>• Toner motor (M11) (magenta) is not properly attached, or it is faulty</li> <li>• The toner motor unit is faulty.</li> <li>• The engine relay PCB (PCB21) is faulty.</li> <li>• The firmware is not the latest version.</li> <li>• The main/engine PCB (PCB1) is faulty.</li> </ul>
		<p>1. Replace the toner cartridge (M).</p> <p>2. Clean the drive gears and the couplings in the toner motor unit and apply the grease to them.</p> <p>3. Reconnect the following wire connectors and clean FFC and reconnect. If there is no continuity, replace the wire. If the FFC terminal section is deformed or FFC is broken, replace the FFC.</p> <ul style="list-style-type: none"> <li>• Toner motor (M11) (magenta) and engine relay PCB (PCB21)</li> <li>• Engine relay PCB (PCB21) and main/engine PCB (PCB1)</li> </ul> <p>4. Reattach toner motor (M11) (magenta). If it is not repaired, replace it.</p> <p>5. Replace the toner motor unit.</p> <p>6. Replace the engine relay PCB (PCB21).</p> <p>7. Upgrade the engine firmware to the latest version.</p> <p>8. Replace the main/engine PCB (PCB1).</p>

SC No.	Type	Error Name/Error Condition/Major Cause/Solution
SC332-04	D	Toner motor (M11) error (yellow)
		The excess current signal was detected for 5 seconds continuously.
		<ul style="list-style-type: none"> <li>• The spiral locks up. (It does not rotate.)</li> </ul>

## 6.Troubleshooting

SC No.	Type	Error Name/Error Condition/Major Cause/Solution
		<ul style="list-style-type: none"> <li>• The drive gear or the coupling do not properly rotate or the excessive load is applied to them.</li> <li>• The connector or FFC is not connected properly. Or, the wire or FFC is faulty.</li> <li>• Toner motor (M11) (yellow) is not properly attached, or it is faulty</li> <li>• The toner motor unit is faulty.</li> <li>• The engine relay PCB (PCB21) is faulty.</li> <li>• The firmware is not the latest version.</li> <li>• The main/engine PCB (PCB1) is faulty.</li> </ul>
		<ol style="list-style-type: none"> <li>1. Replace the toner cartridge (Y).</li> <li>2. Clean the drive gears and the couplings in the toner motor unit and apply the grease to them.</li> <li>3. Reconnect the following wire connectors and clean FFC and reconnect. If there is no continuity, replace the wire. If the FFC terminal section is deformed or FFC is broken, replace the FFC. <ul style="list-style-type: none"> <li>• Toner motor (M11) (yellow) and engine relay PCB (PCB21)</li> <li>• Engine relay PCB (PCB21) and main/engine PCB (PCB1)</li> </ul> </li> <li>4. Reattach toner motor (M11) (yellow). If it is not repaired, replace it.</li> <li>5. Replace the toner motor unit.</li> <li>6. Replace the engine relay PCB (PCB21).</li> <li>7. Upgrade the engine firmware to the latest version.</li> <li>8. Replace the main/engine PCB (PCB1).</li> </ol>

SC No.	Type	Error Name/Error Condition/Major Cause/Solution
SC370-01	C	ID sensor error (left)
		<p>The measurement value of the ID sensor apply either of the following.</p> <ol style="list-style-type: none"> <li>1. The P-wave of the light potential is lower than the p-wave of the dark potential +0.5V.</li> <li>2. The S-wave of the light potential is lower than the S-wave of the dark potential.</li> <li>3. The P/S-wave is more than 0.8V, or lower than 0.15V.</li> </ol>
		<ul style="list-style-type: none"> <li>• ID sensor 1 is dirty.</li> <li>• ID sensor 1 is not properly attached.</li> <li>• The connector is not properly connected or the wire is faulty.</li> <li>• ID sensor 1 is faulty, so the error is detected when executing Calibration.</li> <li>• The firmware is not the latest version.</li> <li>• The main/engine PCB (PCB1) is faulty.</li> </ul>
		<ol style="list-style-type: none"> <li>1. Clean the surface of ID sensor 1.</li> <li>2. Reattach ID sensor 1.</li> </ol>

SC No.	Type	Error Name/Error Condition/Major Cause/Solution
		<ol style="list-style-type: none"> <li>3. Clean the terminal of the following wire connectors and reconnect the connectors. If there is no continuity, replace the wire. ID sensor 1 - main/engine PCB (PCB1).</li> <li>4. Replace ID sensor 1.</li> <li>5. Upgrade the engine firmware to the latest version.</li> <li>6. Replace the main/engine PCB (PCB1).</li> </ol>

SC No.	Type	Error Name/Error Condition/Major Cause/Solution
SC370-02	C	<p>ID sensor error (right)</p> <p>The measurement value of the ID sensor apply either of the following.</p> <ol style="list-style-type: none"> <li>1. The P-wave of the light potential is lower than the p-wave of the dark potential +0.5V.</li> <li>2. The S-wave of the light potential is lower than the S-wave of the dark potential.</li> <li>3. The P/S-wave is more than 0.8V, or lower than 0.15V.</li> </ol> <ul style="list-style-type: none"> <li>• ID sensor 2 is dirty.</li> <li>• ID sensor 2 is not properly attached.</li> <li>• The connector is not properly connected or the wire is faulty.</li> <li>• ID sensor 2 is faulty, so the error is detected when executing Calibration.</li> <li>• The firmware is not the latest version.</li> <li>• The main/engine PCB (PCB1) is faulty.</li> </ul> <ol style="list-style-type: none"> <li>1. Clean the surface of ID sensor 2.</li> <li>2. Reattach ID sensor 2.</li> <li>3. Clean the terminal of the following wire connectors and reconnect the connectors. If there is no continuity, replace the wire. ID sensor 2 - main/engine PCB (PCB1).</li> <li>4. Replace ID sensor 2.</li> <li>5. Upgrade the engine firmware to the latest version.</li> <li>6. Replace the main/engine PCB (PCB1).</li> </ol>

SC No.	Type	Error Name/Error Condition/Major Cause/Solution
SC370-03	C	<p>Bias calibration reading error (black)</p> <p>The ID sensor cannot read the patch image density on the transfer belt normally when executing Calibration.</p> <ul style="list-style-type: none"> <li>• The ID sensor does not operate properly.</li> <li>• The ID sensor is dirty.</li> <li>• Calibration failed last time.</li> <li>• The ID sensor shutter is not opened.</li> </ul>

## 6.Troubleshooting

SC No.	Type	Error Name/Error Condition/Major Cause/Solution
		<ul style="list-style-type: none"> <li>• The transfer belt surface is dirty or scratched.</li> <li>• The drum unit or developer unit parts are dirty or worn down.</li> <li>• The ID sensor is not attached properly.</li> <li>• The connector is not properly connected or the wire is faulty.</li> <li>• ID sensor 1, 2 are abnormal and an error is detected when executing Calibration.</li> <li>• The firmware is not the latest version.</li> <li>• The main/engine PCB (PCB1) is faulty.</li> </ul>
		<ol style="list-style-type: none"> <li>1. Turn off the power switch and pull out the power plug. After passing 5 seconds, reinsert the power plug and turn on the power switch.</li> <li>2. Clean the surface of ID sensor 1/2.</li> <li>3. Execute [Color Calibration] from the [Maintenance] menu.</li> <li>4. Check if the ID sensor shutter opens and closes according to the paper tray opening and closing. If it does not open properly, repair it.</li> <li>5. Clean the surface of the transfer belt. Or replace the ITB unit.</li> <li>6. Clean the drum unit (K) and development unit (K). If the parts are worn down, replace the unit.</li> <li>7. Reinstall ID sensor 1/2.</li> <li>8. Clean the terminal of the following wire connectors and reconnect the connectors. If there is no continuity, replace the wire. ID sensor 1/2 - main/engine PCB (PCB1)</li> <li>9. Replace ID sensor 1/2.</li> <li>10. Upgrade the engine firmware to the latest version.</li> <li>11. Replace the main/engine PCB (PCB1).</li> </ol>

SC No.	Type	Error Name/Error Condition/Major Cause/Solution
SC370-04	C	<p>Bias calibration reading error (cyan)</p> <p>The ID sensor cannot read the patch image density on the transfer belt normally when executing Calibration.</p> <ul style="list-style-type: none"> <li>• The ID sensor does not operate properly.</li> <li>• The ID sensor is dirty.</li> <li>• Calibration failed last time.</li> <li>• The ID sensor shutter is not opened.</li> <li>• The transfer belt surface is dirty or scratched.</li> <li>• The drum unit or developer unit parts are dirty or worn down.</li> <li>• The ID sensor is not attached properly.</li> <li>• The connector is not properly connected or the wire is faulty.</li> <li>• ID sensor 1, 2 are abnormal and an error is detected when executing</li> </ul>

SC No.	Type	Error Name/Error Condition/Major Cause/Solution
		<p>Calibration.</p> <ul style="list-style-type: none"> <li>• The firmware is not the latest version.</li> <li>• The main/engine PCB (PCB1) is faulty.</li> </ul>
		<ol style="list-style-type: none"> <li>1. Turn off the power switch and pull out the power plug. After passing 5 seconds, reinsert the power plug and turn on the power switch.</li> <li>2. Clean the surface of ID sensor 1/2.</li> <li>3. Execute [Color Calibration] from the [Maintenance] menu.</li> <li>4. Check if the ID sensor shutter opens and closes according to the paper tray opening and closing. If it does not open properly, repair it.</li> <li>5. Clean the surface of the transfer belt. Or replace the ITB unit.</li> <li>6. Clean the drum unit (C) and development unit (C). If the parts are worn down, replace the unit.</li> <li>7. Reinstall ID sensor 1/2.</li> <li>8. Clean the terminal of the following wire connectors and reconnect the connectors. If there is no continuity, replace the wire. ID sensor 1/2 - main/engine PCB (PCB1)</li> <li>9. Replace ID sensor 1/2.</li> <li>10. Upgrade the engine firmware to the latest version.</li> <li>11. Replace the main/engine PCB (PCB1).</li> </ol>

SC No.	Type	Error Name/Error Condition/Major Cause/Solution
SC370-05	C	<p>Bias calibration reading error (magenta)</p> <p>The ID sensor cannot read the patch image density on the transfer belt normally when executing Calibration.</p> <ul style="list-style-type: none"> <li>• The ID sensor does not operate properly.</li> <li>• The ID sensor is dirty.</li> <li>• Calibration failed last time.</li> <li>• The ID sensor shutter is not opened.</li> <li>• The transfer belt surface is dirty or scratched.</li> <li>• The drum unit or developer unit parts are dirty or worn down.</li> <li>• The ID sensor is not attached properly.</li> <li>• The connector is not properly connected or the wire is faulty.</li> <li>• ID sensor 1, 2 are abnormal and an error is detected when executing Calibration.</li> <li>• The firmware is not the latest version.</li> <li>• The main/engine PCB (PCB1) is faulty.</li> </ul>
		<ol style="list-style-type: none"> <li>1. Turn off the power switch and pull out the power plug. After passing 5 seconds, reinsert the power plug and turn on the power switch.</li> </ol>

## 6.Troubleshooting

SC No.	Type	Error Name/Error Condition/Major Cause/Solution
		<ol style="list-style-type: none"> <li>2. Clean the surface of ID sensor 1/2.</li> <li>3. Execute [Color Calibration] from the [Maintenance] menu.</li> <li>4. Check if the ID sensor shutter opens and closes according to the paper tray opening and closing. If it does not open properly, repair it.</li> <li>5. Clean the surface of the transfer belt. Or replace the ITB unit.</li> <li>6. Clean the drum unit (M) and development unit (M). If the parts are worn down, replace the unit.</li> <li>7. Reinstall ID sensor 1/2.</li> <li>8. Clean the terminal of the following wire connectors and reconnect the connectors. If there is no continuity, replace the wire. ID sensor 1/2 - main/engine PCB (PCB1)</li> <li>9. Replace ID sensor 1/2.</li> <li>10. Upgrade the engine firmware to the latest version.</li> <li>11. Replace the main/engine PCB (PCB1).</li> </ol>

SC No.	Type	Error Name/Error Condition/Major Cause/Solution
SC370-06	C	<p>Bias calibration reading error (yellow)</p> <p>The ID sensor cannot read the patch image density on the transfer belt normally when executing Calibration.</p> <ul style="list-style-type: none"> <li>• The ID sensor does not operate properly.</li> <li>• The ID sensor is dirty.</li> <li>• Calibration failed last time.</li> <li>• The ID sensor shutter is not opened.</li> <li>• The transfer belt surface is dirty or scratched.</li> <li>• The drum unit or developer unit parts are dirty or worn down.</li> <li>• The ID sensor is not attached properly.</li> <li>• The connector is not properly connected or the wire is faulty.</li> <li>• ID sensor 1, 2 are abnormal and an error is detected when executing Calibration.</li> <li>• The firmware is not the latest version.</li> <li>• The main/engine PCB (PCB1) is faulty.</li> </ul> <ol style="list-style-type: none"> <li>1. Turn off the power switch and pull out the power plug. After passing 5 seconds, reinsert the power plug and turn on the power switch.</li> <li>2. Clean the surface of ID sensor 1/2.</li> <li>3. Execute [Color Calibration] from the [Maintenance] menu.</li> <li>4. Check if the ID sensor shutter opens and closes according to the paper tray opening and closing. If it does not open properly, repair it.</li> <li>5. Clean the surface of the transfer belt. Or replace the ITB unit.</li> </ol>

SC No.	Type	Error Name/Error Condition/Major Cause/Solution
		<ol style="list-style-type: none"> <li>6. Clean the drum unit (Y) and development unit (Y). If the parts are worn down, replace the unit.</li> <li>7. Reinstall ID sensor 1/2.</li> <li>8. Clean the terminal of the following wire connectors and reconnect the connectors. If there is no continuity, replace the wire. ID sensor 1/2 - main/engine PCB (PCB1)</li> <li>9. Replace ID sensor 1/2.</li> <li>10. Upgrade the engine firmware to the latest version.</li> <li>11. Replace the main/engine PCB (PCB1).</li> </ol>

SC No.	Type	Error Name/Error Condition/Major Cause/Solution
SC370-07	C	<p>Color registration timing error</p> <p>The image patch position on the transfer belt is outside the range of the ID sensor reading. The transfer belt surface is dirty or image patch density is light.</p> <ul style="list-style-type: none"> <li>• The ID sensor does not operate properly.</li> <li>• The ID sensor is dirty.</li> <li>• Calibration failed last time.</li> <li>• The ID sensor shutter is not opened.</li> <li>• The transfer belt surface is dirty or scratched.</li> <li>• The parts for the drum unit, developer unit and laser unit is dirty or worn out.</li> <li>• The laser unit or drum unit is not installed in the proper position. The laser unit is faulty.</li> <li>• The ID sensor is not attached properly.</li> <li>• The connector is not properly connected or the wire is faulty.</li> <li>• ID sensor 1, 2 are abnormal and an error is detected when executing Calibration.</li> <li>• The firmware is not the latest version.</li> <li>• The main/engine PCB (PCB1) is faulty.</li> </ul> <ol style="list-style-type: none"> <li>1. Turn off the power switch and pull out the power plug. After passing 5 seconds, reinsert the power plug and turn on the power switch.</li> <li>2. Clean the surface of ID sensor 1/2.</li> <li>3. Execute [Color Calibration] from the [Maintenance] menu.</li> <li>4. Check if the ID sensor shutter opens and closes according to the paper tray opening and closing. If it does not open properly, repair it.</li> <li>5. Clean the transfer belt surface. Or, replace the ITB unit.</li> <li>6. Clean drum unit, developer unit and the laser unit. If the parts are worn down, replace the unit.</li> <li>7. Reinstall the laser unit and the drum unit. If it is not resolved, replace the laser</li> </ol>

## 6.Troubleshooting

SC No.	Type	Error Name/Error Condition/Major Cause/Solution
		<p>unit.</p> <ol style="list-style-type: none"> <li>8. Reattach ID sensor 1/2.</li> <li>9. Clean the terminal of the following wire connectors and reconnect the connectors. If there is no continuity, replace the wire. ID sensor 1/2 - main/engine PCB (PCB1)</li> <li>10. Replace ID sensor 1/2.</li> <li>11. Upgrade the engine firmware to the latest version.</li> <li>12. Replace the main/engine PCB (PCB1).</li> </ol>

SC No.	Type	Error Name/Error Condition/Major Cause/Solution
SC391-02	D	<p>Development unit EEPROM error (black)</p> <ol style="list-style-type: none"> <li>1. No response from the device is detected for 5ms or more 5 times continuously when reading / writing the data.</li> <li>2. The reading data of 2 points mismatches 8 times continuously.</li> <li>3. The reading data and the writing data mismatch 8 times continuously.</li> </ol> <ul style="list-style-type: none"> <li>• The EEPROM data in development unit (K) is faulty.</li> <li>• The connector is not properly connected or the wire is faulty.</li> <li>• The EEPROM in development unit (K) is faulty.</li> <li>• The firmware is not the latest version.</li> <li>• The drum relay PCB (PCB22) is faulty.</li> <li>• The main/engine PCB (PCB1) is faulty.</li> </ul> <ol style="list-style-type: none"> <li>1. Turn off the power switch and pull out the power plug. After passing 5 seconds, reinsert the power plug and turn on the power switch.</li> <li>2. Reinsert development unit (K) into the main unit all the way to reconnect the connector. Also, if the wire is faulty, replace it. <ul style="list-style-type: none"> <li>• Development unit (K) and drum relay PCB (PCB22)</li> <li>• Drum relay PCB (PCB22) and main/engine PCB (PCB1)</li> </ul> </li> <li>3. Replace the development unit (K).</li> <li>4. Upgrade the engine firmware to the latest version.</li> <li>5. Replace the drum relay PCB (PCB22).</li> <li>6. Replace the main/engine PCB (PCB1).</li> </ol>

SC No.	Type	Error Name/Error Condition/Major Cause/Solution
SC391-03	D	<p>Development unit EEPROM error (cyan)</p> <ol style="list-style-type: none"> <li>1. No response from the device is detected for 5ms or more 5 times continuously when reading / writing the data.</li> <li>2. The reading data of 2 points mismatches 8 times continuously.</li> <li>3. The reading data and the writing data mismatch 8 times continuously.</li> </ol>

SC No.	Type	Error Name/Error Condition/Major Cause/Solution
		<ul style="list-style-type: none"> <li>• The EEPROM data in development unit (C) is faulty.</li> <li>• The connector is not properly connected or the wire is faulty.</li> <li>• The EEPROM in development unit (C) is faulty.</li> <li>• The firmware is not the latest version.</li> <li>• The drum relay PCB (PCB22) is faulty.</li> <li>• The main/engine PCB (PCB1) is faulty.</li> </ul>
		<ol style="list-style-type: none"> <li>1. Turn off the power switch and pull out the power plug. After passing 5 seconds, reinsert the power plug and turn on the power switch.</li> <li>2. Reinsert development unit (C) into the main unit all the way to reconnect the connector. Also, if the wire is faulty, replace it. <ul style="list-style-type: none"> <li>• Development unit (C) and drum relay PCB (PCB22)</li> <li>• Drum relay PCB (PCB22) and main/engine PCB (PCB1)</li> </ul> </li> <li>3. Replace the development unit (C).</li> <li>4. Upgrade the engine firmware to the latest version.</li> <li>5. Replace the drum relay PCB (PCB22).</li> <li>6. Replace the main/engine PCB (PCB1).</li> </ol>

SC No.	Type	Error Name/Error Condition/Major Cause/Solution
SC391-04	D	Development unit EEPROM error (magenta)
		<ol style="list-style-type: none"> <li>1. No response from the device is detected for 5ms or more 5 times continuously when reading / writing the data.</li> <li>2. The reading data of 2 points mismatches 8 times continuously.</li> <li>3. The reading data and the writing data mismatch 8 times continuously.</li> </ol>
		<ul style="list-style-type: none"> <li>• The EEPROM data in development unit (M) is faulty.</li> <li>• The connector is not properly connected or the wire is faulty.</li> <li>• The EEPROM in development unit (M) is faulty.</li> <li>• The firmware is not the latest version.</li> <li>• The drum relay PCB (PCB22) is faulty.</li> <li>• The main/engine PCB (PCB1) is faulty.</li> </ul>
		<ol style="list-style-type: none"> <li>1. Turn off the power switch and pull out the power plug. After passing 5 seconds, reinsert the power plug and turn on the power switch.</li> <li>2. Reinsert development unit (M) into the main unit all the way to reconnect the connector. Also, if the wire is faulty, replace it. <ul style="list-style-type: none"> <li>• Development unit (M) and drum relay PCB (PCB22)</li> <li>• Drum relay PCB (PCB22) and main/engine PCB (PCB1)</li> </ul> </li> <li>3. Replace the development unit (M).</li> <li>4. Upgrade the engine firmware to the latest version.</li> <li>5. Replace the drum relay PCB (PCB22).</li> </ol>

## 6.Troubleshooting

SC No.	Type	Error Name/Error Condition/Major Cause/Solution
		6. Replace the main/engine PCB (PCB1).

SC No.	Type	Error Name/Error Condition/Major Cause/Solution
SC391-05	D	Development unit EEPROM error (yellow)
		<ol style="list-style-type: none"> <li>No response from the device is detected for 5ms or more 5 times continuously when reading / writing the data.</li> <li>The reading data of 2 points mismatches 8 times continuously.</li> <li>The reading data and the writing data mismatch 8 times continuously.</li> </ol>
		<ul style="list-style-type: none"> <li>The EEPROM data in development unit (Y) is faulty.</li> <li>The connector is not properly connected or the wire is faulty.</li> <li>The EEPROM in development unit (Y) is faulty.</li> <li>The firmware is not the latest version.</li> <li>The drum relay PCB (PCB22) is faulty.</li> <li>The main/engine PCB (PCB1) is faulty.</li> </ul>
		<ol style="list-style-type: none"> <li>Turn off the power switch and pull out the power plug. After passing 5 seconds, reinsert the power plug and turn on the power switch.</li> <li>Reinsert development unit (Y) into the main unit all the way to reconnect the connector. Also, if the wire is faulty, replace it. <ul style="list-style-type: none"> <li>Development unit (Y) and drum relay PCB (PCB22)</li> <li>Drum relay PCB (PCB22) and main/engine PCB (PCB1)</li> </ul> </li> <li>Replace the development unit (Y).</li> <li>Upgrade the engine firmware to the latest version.</li> <li>Replace the drum relay PCB (PCB22).</li> <li>Replace the main/engine PCB (PCB1).</li> </ol>

SC No.	Type	Error Name/Error Condition/Major Cause/Solution
SC396-01	D	Developer Motor (M5) Error 1 (during operation)
		The steady signal turns off for 2 seconds continuously after the motor is stabilized.
		<ul style="list-style-type: none"> <li>The developer roller is faulty.</li> <li>The developer motor (M5) drive is not transmitted correctly.</li> <li>The connector or FFC is not connected properly. Or, the wire or FFC is faulty.</li> <li>The developer motor (M5) is not properly attached, or it is faulty.</li> <li>The firmware is not the latest version.</li> <li>The engine relay PCB (PCB21) is faulty.</li> <li>The main/engine PCB (PCB1) is faulty.</li> </ul>
		<ol style="list-style-type: none"> <li>Replace development unit C, M or Y if the developer roller does not rotate.</li> <li>Check if the drive gear rotates smoothly and has no excessive load. And apply</li> </ol>

SC No.	Type	Error Name/Error Condition/Major Cause/Solution
		<p>the grease to the frictional parts and repair the related parts so that the drive gear rotates smoothly.</p> <p>3. Reconnect the following wire connectors and clean the FFC and reconnect. If there is no continuity, replace the wire. If the FFC terminal section is deformed or FFC is broken, replace the FFC.</p> <ul style="list-style-type: none"> <li>• Developer motor (M5) - engine relay PCB (PCB21)</li> <li>• Engine relay PCB (PCB21) - main/engine PCB (PCB1)</li> </ul> <p>4. Reattach the developer motor. If it is not repaired, replace it.</p> <p>5. Upgrade the engine firmware to the latest version.</p> <p>6. Replace the engine PCB (PCB21).</p> <p>7. Replace the main/engine PCB (PCB1).</p>

SC No.	Type	Error Name/Error Condition/Major Cause/Solution
SC396-02	D	Developer Motor (M5) Error 1 (during startup)
		The steady signal does not turn on after passing 3s since the motor started up.
		<ul style="list-style-type: none"> <li>• The developer roller is faulty.</li> <li>• The developer motor (M5) drive is not transmitted correctly.</li> <li>• The connector or FFC is not connected properly. Or, the wire or FFC is faulty.</li> <li>• The developer motor (M5) is not properly attached, or it is faulty.</li> <li>• The firmware is not the latest version.</li> <li>• The engine relay PCB (PCB21) is faulty.</li> <li>• The main/engine PCB (PCB1) is faulty.</li> </ul> <p>1. Replace development unit C, M or Y if the developer roller does not rotate.</p> <p>2. Check if the drive gear rotates smoothly and has no excessive load. And apply the grease to the frictional parts and repair the related parts so that the drive gear rotates smoothly.</p> <p>3. Reconnect the following wire connectors and clean the FFC and reconnect. If there is no continuity, replace the wire. If the FFC terminal section is deformed or FFC is broken, replace the FFC.</p> <ul style="list-style-type: none"> <li>• Developer motor (M5) - engine relay PCB (PCB21)</li> <li>• Engine relay PCB (PCB21) - main/engine PCB (PCB1)</li> </ul> <p>4. Reattach the developer motor. If it is not repaired, replace it.</p> <p>5. Upgrade the engine firmware to the latest version.</p> <p>6. Replace the engine PCB (PCB21).</p> <p>7. Replace the main/engine PCB (PCB1).</p>

SC No.	Type	Error Name/Error Condition/Major Cause/Solution
SC397-	D	Drum motor 2 (M8) steady-state error (cyan/yellow)

## 6.Troubleshooting

SC No.	Type	Error Name/Error Condition/Major Cause/Solution
01		<p>The steady signal turns off for 2 seconds continuously after the motor is stabilized.</p> <ul style="list-style-type: none"> <li>• The drum does not rotate smoothly.</li> <li>• The drum motor 2 (M8) drive is not transmitted correctly.</li> <li>• The connector or FFC is not connected properly. Or, the wire or FFC is faulty.</li> <li>• Drum motor 2 (M8) is not properly attached, or it is faulty.</li> <li>• The firmware is not the latest version.</li> <li>• The engine relay PCB (PCB21) is faulty.</li> <li>• The main/engine PCB (PCB1) is faulty.</li> </ul> <ol style="list-style-type: none"> <li>1. Check if the drum and the drum cleaning screw rotates manually. If it locks up, replace drum unit C or Y.</li> <li>2. Check if the drive gear rotates smoothly and has no excessive load. And apply the grease to the frictional parts and repair the related parts so that the drive gear rotates smoothly.</li> <li>3. Reconnect the following wire connectors and clean the FFC and reconnect. If there is no continuity, replace the wire. If the FFC terminal section is deformed or FFC is broken, replace the FFC. <ul style="list-style-type: none"> <li>• Drum motor 2 (M8) - engine relay PCB (PCB21)</li> <li>• Engine relay PCB (PCB21) - main/engine PCB (PCB1)</li> </ul> </li> <li>4. Reattach drum motor 2 (M8). If it is not repaired, replace it.</li> <li>5. Upgrade the engine firmware to the latest version</li> <li>6. Replace the engine relay PCB (PCB21).</li> <li>7. Replace the main/engine PCB (PCB1).</li> </ol>

SC No.	Type	Error Name/Error Condition/Major Cause/Solution
SC397-02	D	<p>Drum motor 2 (M8) standby error (cyan/yellow)</p> <p>The steady signal does not turn on after passing 3 seconds since the motor started up.</p> <ul style="list-style-type: none"> <li>• The drum does not rotate smoothly.</li> <li>• The drum motor 2 (M8) drive is not transmitted correctly.</li> <li>• The connector or FFC is not connected properly. Or, the wire or FFC is faulty.</li> <li>• Drum motor 2 (M8) is not properly attached, or it is faulty.</li> <li>• The firmware is not the latest version.</li> <li>• The engine relay PCB (PCB21) is faulty.</li> <li>• The main/engine PCB (PCB1) is faulty.</li> </ul> <ol style="list-style-type: none"> <li>1. Check if the drum and the drum cleaning screw rotates manually. If it locks up, replace drum unit C or Y.</li> <li>2. Check if the drive gear rotates smoothly and has no excessive load. And apply the grease to the frictional parts and repair the related parts so that the drive</li> </ol>

SC No.	Type	Error Name/Error Condition/Major Cause/Solution
		<p>gear rotates smoothly.</p> <ol style="list-style-type: none"> <li>Reconnect the following wire connectors and clean the FFC and reconnect. If there is no continuity, replace the wire. If the FFC terminal section is deformed or FFC is broken, replace the FFC. <ul style="list-style-type: none"> <li>Drum motor 2 (M8) - engine relay PCB (PCB21)</li> <li>Engine relay PCB (PCB21) - main/engine PCB (PCB1)</li> </ul> </li> <li>Reattach drum motor 2 (M8). If it is not repaired, replace it.</li> <li>Upgrade the engine firmware to the latest version</li> <li>Replace the engine relay PCB (PCB21).</li> <li>Replace the main/engine PCB (PCB1).</li> </ol>

SC No.	Type	Error Name/Error Condition/Major Cause/Solution
SC398-01	D	Drum motor 1 (M7) steady-state error (black/magenta)
		The steady signal turns off for 2 seconds continuously after the motor is stabilized.
		<ul style="list-style-type: none"> <li>The drum does not rotate smoothly.</li> <li>The drum motor 1 (M7) drive is not transmitted correctly.</li> <li>The connector or FFC is not connected properly. Or, the wire or FFC is faulty.</li> <li>Drum motor 1 (M7) is not properly attached, or it is faulty.</li> <li>The firmware is not the latest version.</li> <li>The engine relay PCB (PCB21) is faulty.</li> <li>The main/engine PCB (PCB1) is faulty.</li> </ul>
		<ol style="list-style-type: none"> <li>Check if the drum and the drum cleaning screw rotates manually. If it locks up, replace drum unit K or M.</li> <li>Check if the drive gear rotates smoothly and has no excessive load. And apply the grease to the frictional parts and repair the related parts so that the drive gear rotates smoothly.</li> <li>Reconnect the following wire connectors and clean the FFC and reconnect. If there is no continuity, replace the wire. If the FFC terminal section is deformed or FFC is broken, replace the FFC. <ul style="list-style-type: none"> <li>Drum motor 1 (M7) - engine relay PCB (PCB21)</li> <li>Engine relay PCB (PCB21) - main/engine PCB (PCB1)</li> </ul> </li> <li>Reattach drum motor 1 (M7). If it is not repaired, replace it.</li> <li>Upgrade the engine firmware to the latest version</li> <li>Replace the engine relay PCB (PCB21).</li> <li>Replace the main/engine PCB (PCB1).</li> </ol>

SC No.	Type	Error Name/Error Condition/Major Cause/Solution
SC398-	D	Drum motor 1 (M7) standby error (black/magenta)

## 6.Troubleshooting

SC No.	Type	Error Name/Error Condition/Major Cause/Solution
02		<p>The steady signal does not turn on after passing 3 seconds since the motor started up.</p> <ul style="list-style-type: none"> <li>• The drum does not rotate smoothly.</li> <li>• The drum motor 1 (M7) drive is not transmitted correctly.</li> <li>• The connector or FFC is not connected properly. Or, the wire or FFC is faulty.</li> <li>• Drum motor 1 (M7) is not properly attached, or it is faulty.</li> <li>• The firmware is not the latest version.</li> <li>• The engine relay PCB (PCB21) is faulty.</li> <li>• The main/engine PCB (PCB1) is faulty.</li> </ul> <ol style="list-style-type: none"> <li>1. Check if the drum and the drum cleaning screw rotates manually. If it locks up, replace drum unit K or M.</li> <li>2. Check if the drive gear rotates smoothly and has no excessive load. And apply the grease to the frictional parts and repair the related parts so that the drive gear rotates smoothly.</li> <li>3. Reconnect the following wire connectors and clean the FFC and reconnect. If there is no continuity, replace the wire. If the FFC terminal section is deformed or FFC is broken, replace the FFC. <ul style="list-style-type: none"> <li>• Drum motor 1 (M7) - engine relay PCB (PCB21)</li> <li>• Engine relay PCB (PCB21) - main/engine PCB (PCB1)</li> </ul> </li> <li>4. Reattach drum motor 1 (M7). If it is not repaired, replace it.</li> <li>5. Upgrade the engine firmware to the latest version</li> <li>6. Replace the engine relay PCB (PCB21).</li> <li>7. Replace the main/engine PCB (PCB1).</li> </ol>

## Service Call 441-497

### SC400 (Engine: Imaging 3: Around the Drum)

SC No.	Type	Error Name/Error Condition/Major Cause/Solution
SC441-01	D	Image transfer motor (M6) startup error
		The steady signal does not turn on after passing 3 seconds since the motor started up.
		<ul style="list-style-type: none"> <li>• The image transfer motor (M6) drive is not transmitted correctly.</li> <li>• The connector or FFC is not connected properly. Or, the wire or FFC is faulty.</li> <li>• The image transfer motor (M6) is not properly attached, or it is faulty.</li> <li>• The firmware is not the latest version.</li> <li>• The engine relay PCB (PCB21) is faulty.</li> <li>• The main/engine PCB (PCB1) is faulty.</li> </ul>
		<ol style="list-style-type: none"> <li>1. Check if the excessive load is given by rotating the drive gears, roller and the transfer belt, and clean the drive section for the ITB unit.</li> <li>2. Reconnect the following wire connectors and clean the FFC and reconnect. If there is no continuity, replace the wire. If the FFC terminal section is deformed or FFC is broken, replace the FFC. <ul style="list-style-type: none"> <li>• Image transfer motor (M6) - Engine relay PCB (PCB21)</li> <li>• Engine relay PCB (PCB21) - main/engine PCB (PCB1)</li> </ul> </li> <li>3. Reattach the image transfer motor (M6). If it is not repaired, replace it.</li> <li>4. Upgrade the engine firmware to the latest version.</li> <li>5. Replace the engine relay PCB (PCB21).</li> <li>6. Replace the main/engine PCB (PCB1).</li> </ol>

SC No.	Type	Error Name/Error Condition/Major Cause/Solution
SC441-02	D	Image transfer motor (M6) steady-state error
		The steady signal turns off for 2 seconds continuously after the motor is stabilized.
		<ul style="list-style-type: none"> <li>• The image transfer motor (M6) drive is not transmitted correctly.</li> <li>• The connector or FFC is not connected properly. Or, the wire or FFC is faulty.</li> <li>• The image transfer motor (M6) is not properly attached, or it is faulty.</li> <li>• The firmware is not the latest version.</li> <li>• The engine relay PCB (PCB21) is faulty.</li> <li>• The main/engine PCB (PCB1) is faulty.</li> </ul>
		<ol style="list-style-type: none"> <li>1. Check if the excessive load is given by rotating the drive gears, roller and the transfer belt, and clean the drive section for the ITB unit.</li> <li>2. Reconnect the following wire connectors and clean the FFC and reconnect. If there is no continuity, replace the wire. If the FFC terminal section is deformed</li> </ol>

## 6.Troubleshooting

SC No.	Type	Error Name/Error Condition/Major Cause/Solution
		<p>or FFC is broken, replace the FFC.</p> <ul style="list-style-type: none"> <li>• Image transfer motor (M6) - Engine relay PCB (PCB21)</li> <li>• Engine relay PCB (PCB21) - main/engine PCB (PCB1)</li> </ul> <ol style="list-style-type: none"> <li>3. Reattach the image transfer motor (M6). If it is not repaired, replace it.</li> <li>4. Upgrade the engine firmware to the latest version.</li> <li>5. Replace the engine relay PCB (PCB21).</li> <li>6. Replace the main/engine PCB (PCB1).</li> </ol>

SC No.	Type	Error Name/Error Condition/Major Cause/Solution
SC490-01	D	Toner sensor (S9) K error
		The sensor output value is 0.1 V or smaller, or 3.2 V or larger during a certain time.
		<ul style="list-style-type: none"> <li>• The toner cartridge is not properly installed.</li> <li>• The toner supply opening of the toner cartridge cannot be opened by operating the lever.</li> <li>• The drive gear or the coupling do not properly rotate or the excessive load is applied to them.</li> <li>• The toner supply opening on the ITB unit is not opened even when installing toner cartridge K.</li> <li>• Toner is clogged at the toner supply path in the ITB unit.</li> <li>• The connector or FFC is not connected properly. Or, the wire or FFC is faulty.</li> <li>• The gear or spiral does not rotate in the development unit, or toner sensor (S9) K is faulty.</li> <li>• Toner motor (M11) K is not properly attached, or it is faulty.</li> <li>• The drum relay PCB (PCB22) is faulty.</li> <li>• The engine relay PCB (PCB21) is faulty.</li> <li>• The firmware is not the latest version.</li> <li>• The main/engine PCB (PCB1) is faulty.</li> </ul>
		<ol style="list-style-type: none"> <li>1. Reinstall toner cartridge K.</li> <li>2. Replace toner cartridge K.</li> <li>3. Clean the drive gear and the coupling and apply the grease to them.</li> <li>4. Correct the toner supply opening at the upper part of the ITB unit so that it is opened by the lever operation.</li> <li>5. Clean the inside of the ITB unit. If not resolved, replace it.</li> <li>6. Reconnect the following wire connectors and clean the FFC and reconnect. If there is no continuity, replace the wire. If the FFC terminal section is deformed or FFC is broken, replace the FFC. <ul style="list-style-type: none"> <li>• Development unit K - drum drum relay PCB (PCB22)</li> <li>• Drum relay PCB (PCB22) - main/engine PCB (PCB1)</li> </ul> </li> </ol>

SC No.	Type	Error Name/Error Condition/Major Cause/Solution
		<ul style="list-style-type: none"> <li>• Toner motor (M11) K - engine relay PCB (PCB21)</li> <li>• Engine relay PCB (PCB21) - main/engine PCB (PCB1)</li> </ul> <ol style="list-style-type: none"> <li>7. Replace development unit K.</li> <li>8. Reattach toner motor (M11) K. If it is not repaired, replace it.</li> <li>9. Replace the drum relay PCB (PCB22).</li> <li>10. Replace the engine relay PCB (PCB21).</li> <li>11. Upgrade the engine firmware to the latest version.</li> <li>12. Replace the main/engine PCB (PCB1).</li> </ol>

SC No.	Type	Error Name/Error Condition/Major Cause/Solution
SC490-02	D	Toner sensor (S9) C error
		The sensor output value is 0.1 V or smaller, or 3.2 V or larger during a certain time.
		<ul style="list-style-type: none"> <li>• The toner cartridge is not properly installed.</li> <li>• The toner supply opening of the toner cartridge cannot be opened by operating the lever.</li> <li>• The drive gear or the coupling do not properly rotate or the excessive load is applied to them.</li> <li>• The toner supply opening on the ITB unit is not opened even when installing toner cartridge C.</li> <li>• Toner is clogged at the toner supply path in the ITB unit.</li> <li>• The connector or FFC is not connected properly. Or, the wire or FFC is faulty.</li> <li>• The gear or spiral does not rotate in the development unit, or toner sensor (S9) C is faulty.</li> <li>• Toner motor (M11) C is not properly attached, or it is faulty.</li> <li>• The drum relay PCB (PCB22) is faulty.</li> <li>• The engine relay PCB (PCB21) is faulty.</li> <li>• The firmware is not the latest version.</li> <li>• The main/engine PCB (PCB1) is faulty.</li> </ul>
		<ol style="list-style-type: none"> <li>1. Reinstall toner cartridge C.</li> <li>2. Replace toner cartridge C.</li> <li>3. Clean the drive gear and the coupling and apply the grease to them.</li> <li>4. Correct the toner supply opening at the upper part of the ITB unit so that it is opened by the lever operation.</li> <li>5. Clean the inside of the ITB unit. If not resolved, replace it.</li> <li>6. Reconnect the following wire connectors and clean the FFC and reconnect. If there is no continuity, replace the wire. If the FFC terminal section is deformed or FFC is broken, replace the FFC.</li> </ol> <ul style="list-style-type: none"> <li>• Development unit C - drum drum relay PCB (PCB22)</li> </ul>

## 6.Troubleshooting

SC No.	Type	Error Name/Error Condition/Major Cause/Solution
		<ul style="list-style-type: none"> <li>• Drum relay PCB (PCB22) - main/engine PCB (PCB1)</li> <li>• Toner motor (M11) C - engine relay PCB (PCB21)</li> <li>• Engine relay PCB (PCB21) - main/engine PCB (PCB1)</li> </ul> <ol style="list-style-type: none"> <li>7. Replace development unit C.</li> <li>8. Reattach toner motor (M11) C. If it is not repaired, replace it.</li> <li>9. Replace the drum relay PCB (PCB22).</li> <li>10. Replace the engine relay PCB (PCB21).</li> <li>11. Upgrade the engine firmware to the latest version.</li> <li>12. Replace the main/engine PCB (PCB1).</li> </ol>

SC No.	Type	Error Name/Error Condition/Major Cause/Solution
SC490-03	D	Toner sensor (S9) M error
		The sensor output value is 0.1 V or smaller, or 3.2 V or larger during a certain time.
		<ul style="list-style-type: none"> <li>• The toner cartridge is not properly installed.</li> <li>• The toner supply opening of the toner cartridge cannot be opened by operating the lever.</li> <li>• The drive gear or the coupling do not properly rotate or the excessive load is applied to them.</li> <li>• The toner supply opening on the ITB unit is not opened even when installing toner cartridge M.</li> <li>• Toner is clogged at the toner supply path in the ITB unit.</li> <li>• The connector or FFC is not connected properly. Or, the wire or FFC is faulty.</li> <li>• The gear or spiral does not rotate in the development unit, or toner sensor (S9) M is faulty.</li> <li>• Toner motor (M11) M is not properly attached, or it is faulty.</li> <li>• The drum relay PCB (PCB22) is faulty.</li> <li>• The engine relay PCB (PCB21) is faulty.</li> <li>• The firmware is not the latest version.</li> <li>• The main/engine PCB (PCB1) is faulty.</li> </ul>
		<ol style="list-style-type: none"> <li>1. Reinstall toner cartridge M.</li> <li>2. Replace toner cartridge M.</li> <li>3. Clean the drive gear and the coupling and apply the grease to them.</li> <li>4. Correct the toner supply opening at the upper part of the ITB unit so that it is opened by the lever operation.</li> <li>5. Clean the inside of the ITB unit. If not resolved, replace it.</li> <li>6. Reconnect the following wire connectors and clean the FFC and reconnect. If there is no continuity, replace the wire. If the FFC terminal section is deformed or FFC is broken, replace the FFC.</li> </ol>

SC No.	Type	Error Name/Error Condition/Major Cause/Solution
		<ul style="list-style-type: none"> <li>• Development unit M - drum drum relay PCB (PCB22)</li> <li>• Drum relay PCB (PCB22) - main/engine PCB (PCB1)</li> <li>• Toner motor (M11) M - engine relay PCB (PCB21)</li> <li>• Engine relay PCB (PCB21) - main/engine PCB (PCB1)</li> </ul> <ol style="list-style-type: none"> <li>7. Replace development unit M.</li> <li>8. Reattach toner motor (M11) M. If it is not repaired, replace it.</li> <li>9. Replace the drum relay PCB (PCB22).</li> <li>10. Replace the engine relay PCB (PCB21).</li> <li>11. Upgrade the engine firmware to the latest version.</li> <li>12. Replace the main/engine PCB (PCB1).</li> </ol>

SC No.	Type	Error Name/Error Condition/Major Cause/Solution
SC490-04	D	Toner sensor (S9) Y error
		The sensor output value is 0.1 V or smaller, or 3.2 V or larger during a certain time.
		<ul style="list-style-type: none"> <li>• The toner cartridge is not properly installed.</li> <li>• The toner supply opening of the toner cartridge cannot be opened by operating the lever.</li> <li>• The drive gear or the coupling do not properly rotate or the excessive load is applied to them.</li> <li>• The toner supply opening on the ITB unit is not opened even when installing toner cartridge Y.</li> <li>• Toner is clogged at the toner supply path in the ITB unit.</li> <li>• The connector or FFC is not connected properly. Or, the wire or FFC is faulty.</li> <li>• The gear or spiral does not rotate in the development unit, or toner sensor (S9) Y is faulty.</li> <li>• Toner motor (M11) Y is not properly attached, or it is faulty.</li> <li>• The drum relay PCB (PCB22) is faulty.</li> <li>• The engine relay PCB (PCB21) is faulty.</li> <li>• The firmware is not the latest version.</li> <li>• The main/engine PCB (PCB1) is faulty.</li> </ul>
		<ol style="list-style-type: none"> <li>1. Reinstall toner cartridge Y.</li> <li>2. Replace toner cartridge Y.</li> <li>3. Clean the drive gear and the coupling and apply the grease to them.</li> <li>4. Correct the toner supply opening at the upper part of the ITB unit so that it is opened by the lever operation.</li> <li>5. Clean the inside of the ITB unit. If not resolved, replace it.</li> <li>6. Reconnect the following wire connectors and clean the FFC and reconnect. If there is no continuity, replace the wire. If the FFC terminal section is deformed</li> </ol>

## 6.Troubleshooting

SC No.	Type	Error Name/Error Condition/Major Cause/Solution
		<p>or FFC is broken, replace the FFC.</p> <ul style="list-style-type: none"> <li>• Development unit Y - drum drum relay PCB (PCB22)</li> <li>• Drum relay PCB (PCB22) - main/engine PCB (PCB1)</li> <li>• Toner motor (M11) Y - engine relay PCB (PCB21)</li> <li>• Engine relay PCB (PCB21) - main/engine PCB (PCB1)</li> </ul> <p>7. Replace development unit Y.</p> <p>8. Reattach toner motor (M11) Y. If it is not repaired, replace it.</p> <p>9. Replace the drum relay PCB (PCB22).</p> <p>10. Replace the engine relay PCB (PCB21).</p> <p>11. Upgrade the engine firmware to the latest version.</p> <p>12. Replace the main/engine PCB (PCB1).</p>

SC No.	Type	Error Name/Error Condition/Major Cause/Solution
SC491-02	D	<p>Drum unit EEPROM error (Black)</p> <ol style="list-style-type: none"> <li>1. No response from the device is detected for 5ms or more 5 times continuously when reading / writing the data.</li> <li>2. The reading data of 2 points mismatches 8 times continuously.</li> <li>3. The reading data and the writing data mismatch 8 times continuously.</li> </ol> <ul style="list-style-type: none"> <li>• The EEPROM data in drum unit K is faulty.</li> <li>• The connector is not properly connected or the wire is faulty.</li> <li>• The EEPROM in drum unit K is faulty.</li> <li>• The firmware is not the latest version.</li> <li>• The drum relay PCB (PCB22) is faulty.</li> <li>• The main/engine PCB (PCB1) is faulty.</li> </ul> <ol style="list-style-type: none"> <li>1. Turn off the power switch and pull out the power plug. After passing 5 seconds, reinsert the power plug and turn on the power switch.</li> <li>2. Reinsert drum unit K into the main unit all the way to reconnect the connector. Also, if the wire is faulty, replace it. <ul style="list-style-type: none"> <li>• Drum unit K - drum relay PCB (PCB22)</li> <li>• Drum relay PCB (PCB22) - main/engine PCB (PCB1)</li> </ul> </li> <li>3. Replace drum unit K.</li> <li>4. Upgrade the engine firmware to the latest version.</li> <li>5. Replace the drum relay PCB (PCB22).</li> <li>6. Replace the main/engine PCB (PCB1).</li> </ol>

SC No.	Type	Error Name/Error Condition/Major Cause/Solution
SC491-03	D	<p>Drum unit EEPROM error (Cyan)</p> <ol style="list-style-type: none"> <li>1. No response from the device is detected for 5ms or more 5 times continuously</li> </ol>

SC No.	Type	Error Name/Error Condition/Major Cause/Solution
		<p>when reading / writing the data.</p> <ol style="list-style-type: none"> <li>The reading data of 2 points mismatches 8 times continuously.</li> <li>The reading data and the writing data mismatch 8 times continuously.</li> </ol>
		<ul style="list-style-type: none"> <li>The EEPROM data in drum unit C is faulty.</li> <li>The connector is not properly connected or the wire is faulty.</li> <li>The EEPROM in drum unit C is faulty.</li> <li>The firmware is not the latest version.</li> <li>The drum relay PCB (PCB22) is faulty.</li> <li>The main/engine PCB (PCB1) is faulty.</li> </ul>
		<ol style="list-style-type: none"> <li>Turn off the power switch and pull out the power plug. After passing 5 seconds, reinsert the power plug and turn on the power switch.</li> <li>Reinsert drum unit C into the main unit all the way to reconnect the connector. Also, if the wire is faulty, replace it. <ul style="list-style-type: none"> <li>Drum unit C - drum relay PCB (PCB22)</li> <li>Drum relay PCB (PCB22) - main/engine PCB (PCB1)</li> </ul> </li> <li>Replace drum unit C.</li> <li>Upgrade the engine firmware to the latest version.</li> <li>Replace the drum relay PCB (PCB22).</li> <li>Replace the main/engine PCB (PCB1).</li> </ol>

SC No.	Type	Error Name/Error Condition/Major Cause/Solution
SC491-04	D	Drum unit EEPROM error (Magenta)
		<ol style="list-style-type: none"> <li>No response from the device is detected for 5ms or more 5 times continuously when reading / writing the data.</li> <li>The reading data of 2 points mismatches 8 times continuously.</li> <li>The reading data and the writing data mismatch 8 times continuously.</li> </ol>
		<ul style="list-style-type: none"> <li>The EEPROM data in drum unit M is faulty.</li> <li>The connector is not properly connected or the wire is faulty.</li> <li>The EEPROM in drum unit M is faulty.</li> <li>The firmware is not the latest version.</li> <li>The drum relay PCB (PCB22) is faulty.</li> <li>The main/engine PCB (PCB1) is faulty.</li> </ul>
		<ol style="list-style-type: none"> <li>Turn off the power switch and pull out the power plug. After passing 5 seconds, reinsert the power plug and turn on the power switch.</li> <li>Reinsert drum unit M into the main unit all the way to reconnect the connector. Also, if the wire is faulty, replace it. <ul style="list-style-type: none"> <li>Drum unit M - drum relay PCB (PCB22)</li> <li>Drum relay PCB (PCB22) - main/engine PCB (PCB1)</li> </ul> </li> </ol>

## 6.Troubleshooting

SC No.	Type	Error Name/Error Condition/Major Cause/Solution
		<ol style="list-style-type: none"> <li>3. Replace drum unit M.</li> <li>4. Upgrade the engine firmware to the latest version.</li> <li>5. Replace the drum relay PCB (PCB22).</li> <li>6. Replace the main/engine PCB (PCB1).</li> </ol>

SC No.	Type	Error Name/Error Condition/Major Cause/Solution
SC491-05	D	Drum unit EEPROM error (Yellow)
		<ol style="list-style-type: none"> <li>1. No response from the device is detected for 5ms or more 5 times continuously when reading / writing the data.</li> <li>2. The reading data of 2 points mismatches 8 times continuously.</li> <li>3. The reading data and the writing data mismatch 8 times continuously.</li> </ol>
		<ul style="list-style-type: none"> <li>• The EEPROM data in drum unit Y is faulty.</li> <li>• The connector is not properly connected or the wire is faulty.</li> <li>• The EEPROM in drum unit Y is faulty.</li> <li>• The firmware is not the latest version.</li> <li>• The drum relay PCB (PCB22) is faulty.</li> <li>• The main/engine PCB (PCB1) is faulty.</li> </ul>
		<ol style="list-style-type: none"> <li>1. Turn off the power switch and pull out the power plug. After passing 5 seconds, reinsert the power plug and turn on the power switch.</li> <li>2. Reinsert drum unit Y into the main unit all the way to reconnect the connector. Also, if the wire is faulty, replace it. <ul style="list-style-type: none"> <li>• Drum unit Y - drum relay PCB (PCB22)</li> <li>• Drum relay PCB (PCB22) - main/engine PCB (PCB1)</li> </ul> </li> <li>3. Replace drum unit Y.</li> <li>4. Upgrade the engine firmware to the latest version.</li> <li>5. Replace the drum relay PCB (PCB22).</li> <li>6. Replace the main/engine PCB (PCB1).</li> </ol>

SC No.	Type	Error Name/Error Condition/Major Cause/Solution
SC492-01	D	Drum unit type mismatch (black)
		The main unit and drum unit K is not matched.
		The correct drum unit is not installed in the slot for drum unit (K).
		Install the correct drum unit.

SC No.	Type	Error Name/Error Condition/Major Cause/Solution
SC492-02	D	Drum unit type mismatch (cyan)
		The main unit and drum unit C is not matched.

SC No.	Type	Error Name/Error Condition/Major Cause/Solution
		The correct drum unit is not installed in the slot for drum unit (C).
		Install the correct drum unit.

SC No.	Type	Error Name/Error Condition/Major Cause/Solution
SC492-03	D	Drum unit type mismatch (magenta)
		The main unit and drum unit M is not matched.
		The correct drum unit is not installed in the slot for drum unit (M).
		Install the correct drum unit.

SC No.	Type	Error Name/Error Condition/Major Cause/Solution
SC492-04	D	Drum unit type mismatch (yellow)
		The main unit and drum unit Y is not matched.
		The correct drum unit is not installed in the slot for drum unit (Y).
		Install the correct drum unit.

SC No.	Type	Error Name/Error Condition/Major Cause/Solution
SC497-00	C	Developer thermistor error
		The sensor input sampling exceeds the reference value. (After detection, controlled at 25 °C / 77.0 °F)
		<ul style="list-style-type: none"> <li>• The connector is not properly connected or the wire is faulty.</li> <li>• Toner sensor K is faulty.</li> <li>• The drum relay PCB (PCB22) is faulty.</li> <li>• The firmware is not the latest version.</li> <li>• The main/engine PCB (PCB1) is faulty.</li> </ul>
		<ol style="list-style-type: none"> <li>1. Reinsert development unit K into the main unit all the way to reconnect the connector. Also, if the wire is faulty, replace it. <ul style="list-style-type: none"> <li>• Development unit K - drum relay PCB (PCB22)</li> <li>• Drum relay PCB (PCB22) - main/engine PCB (PCB1)</li> </ul> </li> <li>2. Replace development unit K.</li> <li>3. Replace the drum relay PCB (PCB22).</li> <li>4. Upgrade the engine firmware to the latest version.</li> <li>5. Replace the main/engine PCB (PCB1).</li> </ol>



## Service Call 501-580

### SC500 (Engine: Paper Transport 1: Paper Feed, Duplex, Transport)

SC No.	Type	Error Name/Error Condition/Major Cause/Solution
SC501-01	D	Paper Feed Tray Lift Motor (M9) Error (Tray 1)
		<p>After installing paper feed tray 1, either of the following 1 to 4 is detected 5 times continuously.</p> <ol style="list-style-type: none"> <li>1. The lift motor (M9) excess current is detected for 80 ms.</li> <li>2. The lift sensor does not turn on when passing 10 seconds after installing the cassette.</li> <li>3. During printing, after detecting the lift sensor off, the lift sensor does not turn on when passing 1 second after the ascending control.</li> <li>4. During motor operation, the lock signal is detected for 1 second continuously and it is detected 5 times continuously.</li> </ol>
		<ul style="list-style-type: none"> <li>• The lift plate does not operate properly.</li> <li>• The drive gear does not rotate properly.</li> <li>• The connector or FFC is not connected properly. Or, the wire or FFC is faulty.</li> <li>• The lift motor (M9) is not properly attached, or it is faulty.</li> <li>• The lift sensor is not properly attached, or it is faulty.</li> <li>• The engine relay PCB (PCB21) is faulty.</li> <li>• The firmware is not the latest version.</li> <li>• The main/engine PCB (PCB1) is faulty.</li> </ul>
		<ol style="list-style-type: none"> <li>1. If the lift plate does not ascend or descend, correct it or replace it.</li> <li>2. Check if MP lift plate elevation drive gears rotate or have no excessive load. And apply the grease to the frictional parts and repair the related parts so that they can rotate properly.</li> <li>3. Reconnect the following wire connectors and clean the FFC and reconnect. If there is no continuity, replace the wire. If the FFC terminal section is deformed or FFC is broken, replace the FFC. <ul style="list-style-type: none"> <li>• Lift sensor - engine relay PCB (PCB21)</li> <li>• Engine relay PCB (PCB21) - main/engine PCB (PCB1)</li> </ul> </li> <li>4. Reattach the lift motor (M9). If it is not repaired, replace it.</li> <li>5. Reattach PF lift upper limit sensor. If not repaired, replace it.</li> <li>6. Replace the engine relay PCB (PCB21).</li> <li>7. Upgrade the engine firmware to the latest version.</li> <li>8. Replace the main/engine PCB (PCB1).</li> </ol>

## 6.Troubleshooting

SC No.	Type	Error Name/Error Condition/Major Cause/Solution
SC502-01	D	PF Lift Motor Error (Tray 2)
		<p>After installing paper feed tray 2, either of the following 1 to 3 is detected 5 times continuously.</p> <ol style="list-style-type: none"> <li>1. The PF lift motor excess current is detected for 80 ms.</li> <li>2. The PF lift sensor does not turn on when passing 10 seconds after installing the cassette.</li> <li>3. During printing, after detecting the PF lift sensor off, the PF lift sensor does not turn on when passing 1 second after the ascending control.</li> </ol>
		<ul style="list-style-type: none"> <li>• The lift plate does not operate properly.</li> <li>• The drive gear does not rotate properly.</li> <li>• The paper feeder is not properly installed.</li> <li>• The connector or FFC is not connected properly. Or, the wire or FFC is faulty.</li> <li>• The PF lift motor is not properly attached, or it is faulty.</li> <li>• The PF lift sensor is not properly attached, or it is faulty.</li> <li>• The PF main PCB is faulty.</li> <li>• The firmware is not the latest version.</li> <li>• The engine relay PCB (PCB21) is faulty.</li> </ul>
<ol style="list-style-type: none"> <li>1. If the lift plate does not ascend or descend, correct it or replace it.</li> <li>2. Check if MP lift plate elevation drive gears rotate or have no excessive load. And apply the grease to the frictional parts and repair the related parts so that they can rotate properly.</li> <li>3. Reinstall the paper feeder.</li> <li>4. Reconnect the following wire connectors and clean the FFC and reconnect. If there is no continuity, replace the wire. If the FFC terminal section is deformed or FFC is broken, replace the FFC. <ul style="list-style-type: none"> <li>• PF lift sensor - PF main PCB</li> <li>• PF lift motor - PF main PCB</li> <li>• PF main PCB - drawer connector</li> <li>• Drawer connector - PF main PCB (Tray 2)</li> </ul> </li> <li>5. Reattach the PF lift motor. If it is not repaired, replace it.</li> <li>6. Reattach PF lift upper limit sensor. If not repaired, replace it.</li> <li>7. Replace the PF main PCB.</li> <li>8. Upgrade the engine firmware to the latest version.</li> <li>9. Replace the engine relay PCB (PCB21).</li> </ol>		

SC No.	Type	Error Name/Error Condition/Major Cause/Solution
SC502-02	D	Paper Feed Tray Error (Tray 2)
		The steady signal does not turn on for 5 seconds continuously when the motor

SC No.	Type	Error Name/Error Condition/Major Cause/Solution
		drives.
		<ul style="list-style-type: none"> <li>• The paper feed motor drive is not transmitted correctly.</li> <li>• The connector is not properly connected or the wire is faulty.</li> <li>• The paper feed motor is not properly attached, or it is faulty.</li> <li>• The PF main PCB is faulty.</li> </ul>
		<ol style="list-style-type: none"> <li>1. Check if the paper feed roller or the drive gear rotates or have no excessive load. And apply the grease to the frictional parts and repair the related parts so that the drive gear rotates properly.</li> <li>2. Clean the terminal of the following wire connectors and reconnect the connectors. If there is no continuity, replace the wire. Paper feed motor - PF main PCB</li> <li>3. Reattach the PF feed motor. If it is not repaired, replace it.</li> <li>4. Replace the PF main PCB.</li> </ol>

SC No.	Type	Error Name/Error Condition/Major Cause/Solution
SC503-01	D	PF Lift Motor Error (Tray 3)
		After installing paper feed tray 3, either of the following 1 to 3 is detected 5 times continuously.
		<ol style="list-style-type: none"> <li>1. The PF lift motor excess current is detected for 80 ms.</li> <li>2. The PF lift sensor does not turn on when passing 10 seconds after installing the cassette.</li> <li>3. During printing, after detecting the PF lift sensor off, the PF lift sensor does not turn on when passing 1 second after the ascending control.</li> </ol>
		<ul style="list-style-type: none"> <li>• The lift plate does not operate properly.</li> <li>• The drive gear does not rotate properly.</li> <li>• The paper feeder is not properly installed.</li> <li>• The connector or FFC is not connected properly. Or, the wire or FFC is faulty.</li> <li>• The PF lift motor is not properly attached, or it is faulty.</li> <li>• The PF lift sensor is not properly attached, or it is faulty.</li> <li>• The PF main PCB is faulty.</li> </ul>
		<ol style="list-style-type: none"> <li>1. If the lift plate does not ascend or descend, correct it or replace it.</li> <li>2. Check if MP lift plate elevation drive gears rotate or have no excessive load. And apply the grease to the frictional parts and repair the related parts so that they can rotate properly.</li> <li>3. Reinstall the paper feeder.</li> <li>4. Reconnect the following wire connectors and clean the FFC and reconnect. If there is no continuity, replace the wire. If the FFC terminal section is deformed or FFC is broken, replace the FFC.</li> </ol>

## 6.Troubleshooting

SC No.	Type	Error Name/Error Condition/Major Cause/Solution
		<ul style="list-style-type: none"> <li>• PF lift sensor - PF main PCB</li> <li>• PF lift motor (M9) - PF main PCB</li> <li>• PF main PCB - drawer connector</li> <li>• Drawer connector - PF main PCB (Tray 3)</li> </ul> <ol style="list-style-type: none"> <li>5. Reattach the PF lift motor. If it is not repaired, replace it.</li> <li>6. Reattach PF lift upper limit sensor. If not repaired, replace it.</li> <li>7. Replace the PF main PCB.</li> </ol>

SC No.	Type	Error Name/Error Condition/Major Cause/Solution
SC503-02	D	Paper Feed Tray Error (Tray 3)
		The steady signal does not turn on for 5 seconds continuously when the motor drives.
		<ul style="list-style-type: none"> <li>• The paper feed motor drive is not transmitted correctly.</li> <li>• The connector is not properly connected or the wire is faulty.</li> <li>• The paper feed motor is not properly attached, or it is faulty.</li> <li>• The PF main PCB is faulty.</li> </ul>
		<ol style="list-style-type: none"> <li>1. Check if the paper feed roller or the drive gear rotates or have no excessive load. And apply the grease to the frictional parts and repair the related parts so that the drive gear rotates properly.</li> <li>2. Clean the terminal of the following wire connectors and reconnect the connectors. If there is no continuity, replace the wire. Paper feed motor - PF main PCB</li> <li>3. Reattach the PF feed motor. If it is not repaired, replace it.</li> <li>4. Replace the PF main PCB.</li> </ol>

SC No.	Type	Error Name/Error Condition/Major Cause/Solution
SC504-01	D	PF Lift Motor Error (Tray 4)
		After installing paper feed tray 4, either of the following 1 to 3 is detected 5 times continuously.
		<ol style="list-style-type: none"> <li>1. The PF lift motor excess current is detected for 80 ms.</li> <li>2. The PF lift sensor does not turn on when passing 10 seconds after installing the cassette.</li> <li>3. During printing, after detecting the PF lift sensor off, the PF lift sensor does not turn on when passing 1 second after the ascending control.</li> </ol>
		<ul style="list-style-type: none"> <li>• The lift plate does not operate properly.</li> <li>• The drive gear does not rotate properly.</li> <li>• The paper feeder is not properly installed.</li> <li>• The connector or FFC is not connected properly. Or, the wire or FFC is faulty.</li> </ul>

SC No.	Type	Error Name/Error Condition/Major Cause/Solution
		<ul style="list-style-type: none"> <li>• The PF lift motor is not properly attached, or it is faulty.</li> <li>• The PF lift sensor is not properly attached, or it is faulty.</li> <li>• The PF main PCB is faulty.</li> </ul>
		<ol style="list-style-type: none"> <li>1. If the lift plate does not ascend or descend, correct it or replace it.</li> <li>2. Check if MP lift plate elevation drive gears rotate or have no excessive load. And apply the grease to the frictional parts and repair the related parts so that they can rotate properly.</li> <li>3. Reinstall the paper feeder.</li> <li>4. Reconnect the following wire connectors and clean the FFC and reconnect. If there is no continuity, replace the wire. If the FFC terminal section is deformed or FFC is broken, replace the FFC. <ul style="list-style-type: none"> <li>• PF lift sensor - PF main PCB</li> <li>• PF lift motor - PF main PCB</li> <li>• PF main PCB - drawer connector</li> <li>• Drawer connector - PF main PCB (Tray 4)</li> </ul> </li> <li>5. Reattach the PF lift motor. If it is not repaired, replace it.</li> <li>6. Reattach PF lift upper limit sensor. If not repaired, replace it.</li> <li>7. Replace the PF main PCB.</li> </ol>

SC No.	Type	Error Name/Error Condition/Major Cause/Solution
SC504-02	D	Paper Feed Tray Error (Tray 4)
		The steady signal does not turn on for 5 seconds continuously when the motor drives.
		<ul style="list-style-type: none"> <li>• The paper feed motor drive is not transmitted correctly.</li> <li>• The connector is not properly connected or the wire is faulty.</li> <li>• The paper feed motor is not properly attached, or it is faulty.</li> <li>• The PF main PCB is faulty.</li> </ul>
		<ol style="list-style-type: none"> <li>1. Check if the paper feed roller or the drive gear rotates or have no excessive load. And apply the grease to the frictional parts and repair the related parts so that the drive gear rotates properly.</li> <li>2. Clean the terminal of the following wire connectors and reconnect the connectors. If there is no continuity, replace the wire. Paper feed motor - PF main PCB</li> <li>3. Reattach the PF feed motor. If it is not repaired, replace it.</li> <li>4. Replace the PF main PCB.</li> </ol>

SC No.	Type	Error Name/Error Condition/Major Cause/Solution
SC520-	D	Transport Developer Motor (M4) Error

## 6.Troubleshooting

SC No.	Type	Error Name/Error Condition/Major Cause/Solution
00		The steady signal does not turn on after passing 3s since the motor started up or the steady signal turns off for 2s continuously after the motor is stabilized.
		<ul style="list-style-type: none"> <li>• The transport developer motor (M4) drive is not transmitted correctly.</li> <li>• The connector or FFC is not connected properly. Or, the wire or FFC is faulty.</li> <li>• The transport developer motor (M4) is not properly attached, or it is faulty.</li> <li>• The conveying drive unit is faulty.</li> <li>• The firmware is not the latest version.</li> <li>• The engine relay PCB (PCB21) is faulty.</li> <li>• The main/engine PCB (PCB1) is faulty.</li> </ul>
		<ol style="list-style-type: none"> <li>1. Check if the paper conveying roller and the drive gear rotate smoothly and have no excessive load. And apply the grease to the frictional parts and repair the related parts so that the drive gear rotates smoothly.</li> <li>2. Reconnect the following wire connectors and clean the FFC and reconnect. If there is no continuity, replace the wire. If the FFC terminal section is deformed or FFC is broken, replace the FFC. <ul style="list-style-type: none"> <li>• Transport developer motor (M4) - engine relay PCB (PCB21)</li> <li>• Engine relay PCB (PCB21) - main/engine PCB (PCB1)</li> <li>• Laser unit - main/engine PCB (PCB1)</li> </ul> </li> <li>3. Reattach the transport developer motor (M4). If it is not repaired, replace it.</li> <li>4. Replace the conveying drive unit.</li> <li>5. Upgrade the engine firmware to the latest version.</li> <li>6. Replace the engine relay PCB (PCB21).</li> <li>7. Replace the main/engine PCB (PCB1).</li> </ol>

SC No.	Type	Error Name/Error Condition/Major Cause/Solution
SC580-01	C	Paper Feeder EEPROM error (Tray 2)
		The writing data and the reading data mismatch 4 times continuously when writing.
		<ul style="list-style-type: none"> <li>• The paper feeder is not properly installed.</li> <li>• The connector is not properly connected or the wire is faulty.</li> <li>• The PF main PCB is faulty.</li> </ul>
		<ol style="list-style-type: none"> <li>1. Reinstall the paper feeder.</li> <li>2. Reinsert the connectors into all the connectors on the PF main PCB. Also, if there is no continuity, replace the wire.</li> <li>3. Replace the PF main PCB.</li> </ol>

SC No.	Type	Error Name/Error Condition/Major Cause/Solution
SC580-	C	Paper Feeder EEPROM error (Tray 3)

SC No.	Type	Error Name/Error Condition/Major Cause/Solution
02		The writing data and the reading data mismatch 4 times continuously when writing.
		<ul style="list-style-type: none"> <li>• The paper feeder is not properly installed.</li> <li>• The connector is not properly connected or the wire is faulty.</li> <li>• The PF main PCB is faulty.</li> </ul>
		<ol style="list-style-type: none"> <li>1. Reinstall the paper feeder.</li> <li>2. Reinsert the connectors into all the connectors on the PF main PCB. Also, if there is no continuity, replace the wire.</li> <li>3. Replace the PF main PCB.</li> </ol>

SC No.	Type	Error Name/Error Condition/Major Cause/Solution
SC580-03	C	Paper Feeder EEPROM error (Tray 4)
		The writing data and the reading data mismatch 4 times continuously when writing.
		<ul style="list-style-type: none"> <li>• The paper feeder is not properly installed.</li> <li>• The connector is not properly connected or the wire is faulty.</li> <li>• The PF main PCB is faulty.</li> </ul>
		<ol style="list-style-type: none"> <li>1. Reinstall the paper feeder.</li> <li>2. Reinsert the connectors into all the connectors on the PF main PCB. Also, if there is no continuity, replace the wire.</li> <li>3. Replace the PF main PCB.</li> </ol>

---

### SC500 (Engine: Paper Transport 2: Fusing, Others)

---

SC No.	Type	Error Name/Error Condition/Major Cause/Solution
SC540-01	D	Press-release sensor (S2) error
		The press-release sensor (S2) does not turn on or off after passing 30 seconds from the start of the fuser compression or decompression.
		<ul style="list-style-type: none"> <li>• The fusing thermistor cannot detect the normal temperature with paper strip.</li> <li>• The fuser press-release does not operate properly.</li> <li>• The press-release sensor (S2) is not properly attached.</li> <li>• The connector or FFC is not connected properly. Or, the wire or FFC is faulty.</li> <li>• The fusing motor is not properly attached, or it is faulty.</li> <li>• The parts such as the press-release sensor (S2) in the fusing unit are faulty.</li> <li>• The paper exit PCB (PCB8) is faulty.</li> <li>• The engine relay PCB (PCB21) is faulty.</li> <li>• The firmware is not the latest version.</li> <li>• The main/engine PCB (PCB1) is faulty.</li> </ul>

## 6.Troubleshooting

SC No.	Type	Error Name/Error Condition/Major Cause/Solution
		<ol style="list-style-type: none"> <li>1. Remove a piece of paper remaining in the fusing unit.</li> <li>2. Check if the pressure can be reduced by reverse-rotating the fuser gear.</li> <li>3. Check if the press-release sensor (S2) is interrupted by the actuator during the decompression operation.</li> <li>4. Reconnect the following wire connectors and clean FFC and reconnect. If there is no continuity, replace the wire. If the FFC terminal section is deformed or FFC is broken, replace the FFC. <ul style="list-style-type: none"> <li>• Press-release sensor (S2) - paper exit PCB (PCB8)</li> <li>• Paper exit PCB (PCB8) - main/engine PCB (PCB1)</li> <li>• Fusing motor (M2) - engine relay PCB (PCB21)</li> <li>• Engine relay PCB (PCB21) - main/engine PCB (PCB1)</li> </ul> </li> <li>5. Reattach the fusing motor. If it is not repaired, replace it.</li> <li>6. Replace the fusing unit.</li> <li>7. Replace the paper exit PCB (PCB8).</li> <li>8. Replace the engine relay PCB (PCB21).</li> <li>9. Upgrade the engine firmware to the latest version.</li> <li>10. Replace the main/engine PCB (PCB1).</li> </ol>

SC No.	Type	Error Name/Error Condition/Major Cause/Solution
SC541-00	D	<p>Broken fusing thermistor 1 (TH1) error</p> <p>Fusing thermistor 2 (TH2) detects the low temperature for 1.6 seconds when the fusing thermistor 1 (TH1) detects 30 °C / 86 °F or higher.</p> <ul style="list-style-type: none"> <li>• The fusing thermistor cannot detect the normal temperature with paper strip.</li> <li>• The connector is not properly connected or the wire is faulty.</li> <li>• The normal temperature cannot be detected with the fusing heater not being turned on, broken fusing thermostat wire, etc.</li> <li>• The firmware is not the latest version.</li> <li>• The main/engine PCB (PCB1) is faulty.</li> <li>• The paper exit PCB (PCB8) is faulty.</li> </ul> <ol style="list-style-type: none"> <li>1. Remove a piece of paper remaining in the fuser unit.</li> <li>2. Clean the terminal of the following wire connectors and reconnect the connectors. If there is no continuity, replace the wire. <ul style="list-style-type: none"> <li>• Fusing unit (fusing thermistor) - paper exit PCB (PCB8)</li> <li>• Paper exit PCB (PCB8) - main/engine PCB (PCB1)</li> </ul> </li> <li>3. Replace the fuser unit.</li> <li>4. Upgrade the engine firmware to the latest version.</li> <li>5. Replace the main/engine PCB (PCB1).</li> <li>6. Replace the paper exit PCB (PCB8).</li> </ol>

SC No.	Type	Error Name/Error Condition/Major Cause/Solution
SC542-00	D	Fusing thermistor 2 (TH2) low temperature error
		During standby or printing, the fusing thermistor 2 (TH2) detected 100°C / 212°F or less for 1 second continuously.
		<ul style="list-style-type: none"> <li>• The power supply voltage reduces.</li> <li>• The fusing thermistor cannot detect the normal temperature with paper strip.</li> <li>• The connector is not properly connected or the wire is faulty.</li> <li>• The normal temperature cannot be detected with the fusing heater not being turned on, broken fusing thermostat wire, etc.</li> <li>• The firmware is not the latest version.</li> <li>• The main/engine PCB (PCB1) is faulty.</li> <li>• The PSU (PCB9) is faulty.</li> <li>• The paper exit PCB (PCB8) is faulty.</li> </ul>
		<ol style="list-style-type: none"> <li>1. Connect the power cord to a different wall outlet if the power supply voltage descends by 10% or more of the rated voltage, or multiple devices use the same outlet.</li> <li>2. Remove a piece of paper remaining in the fuser unit.</li> <li>3. Clean the terminal of the following wire connectors and reconnect the connectors. If there is no continuity, replace the wire. <ul style="list-style-type: none"> <li>• Fusing unit (fusing thermistor) - paper exit PCB (PCB8)</li> <li>• Paper exit PCB (PCB8) - main/engine PCB (PCB1)</li> <li>• PSU (PCB9) - main/engine PCB (PCB1)</li> </ul> </li> <li>4. Replace the fusing unit.</li> <li>5. Upgrade the engine firmware to the latest version</li> <li>6. Replace the main/engine PCB (PCB1).</li> <li>7. Replace the PSU (PCB9) when the fusing heaters always turn on.</li> <li>8. Replace the paper exit PCB (PCB8).</li> </ol>

SC No.	Type	Error Name/Error Condition/Major Cause/Solution
SC543-00	D	Fusing thermistor 2 (TH2) high temperature error
		Fusing thermistor 2 (TH2) detects 240°C / 464°F or more for 1 second.
		<ul style="list-style-type: none"> <li>• The fusing thermistor cannot detect the normal temperature with paper strip.</li> <li>• The connector is not properly connected or the wire is faulty.</li> <li>• The fusing thermistor cannot detect correct temperature due to foreign objects adhering to the fusing heat roller or fusing press roller, short-circuit of the fusing thermistor, etc.</li> <li>• The firmware is not the latest version.</li> <li>• The main/engine PCB (PCB1) is faulty.</li> </ul>

## 6.Troubleshooting

SC No.	Type	Error Name/Error Condition/Major Cause/Solution
		<ul style="list-style-type: none"> <li>• The PSU (PCB9) is faulty.</li> <li>• The paper exit PCB (PCB8) is faulty.</li> </ul>
		<ol style="list-style-type: none"> <li>1. Remove a piece of paper remaining in the fuser unit.</li> <li>2. Clean the terminal of the following wire connectors and reconnect the connectors. If there is no continuity, replace the wire. <ul style="list-style-type: none"> <li>• Fusing unit (fusing thermistor) - paper exit PCB (PCB8)</li> <li>• Paper exit PCB (PCB8) - main/engine PCB (PCB1)</li> <li>• PSU (PCB9) - main/engine PCB (PCB1)</li> </ul> </li> <li>3. Replace the fusing unit.</li> <li>4. Upgrade the engine firmware to the latest version</li> <li>5. Replace the main/engine PCB (PCB1).</li> <li>6. Replace the PSU (PCB9) when the fusing heaters always turn on.</li> <li>7. Replace the paper exit PCB (PCB8).</li> </ol>

SC No.	Type	Error Name/Error Condition/Major Cause/Solution
SC544-01	D	Fusing heater error
		The input from fusing thermistor 2 (TH2) is abnormal for 1 second continuously.
		<ul style="list-style-type: none"> <li>• The fusing thermistor cannot detect the normal temperature with paper strip.</li> <li>• The connector is not properly connected or the wire is faulty.</li> <li>• The normal temperature cannot be detected with the fusing heater not being turned on, broken fusing thermostat wire, etc.</li> <li>• The firmware is not the latest version.</li> <li>• The main/engine PCB (PCB1) is faulty.</li> <li>• The paper exit PCB (PCB8) is faulty.</li> </ul>
		<ol style="list-style-type: none"> <li>1. Remove a piece of paper remaining in the fuser unit.</li> <li>2. Clean the terminal of the following wire connectors and reconnect the connectors. If there is no continuity, replace the wire. <ul style="list-style-type: none"> <li>• Fusing unit (fusing thermistor) - paper exit PCB (PCB8)</li> <li>• Paper exit PCB (PCB8) - main/engine PCB (PCB1)</li> </ul> </li> <li>3. Replace the fusing unit.</li> <li>4. Upgrade the engine firmware to the latest version</li> <li>5. Replace the main/engine PCB (PCB1).</li> <li>6. Replace the paper exit PCB (PCB8).</li> </ol>

SC No.	Type	Error Name/Error Condition/Major Cause/Solution
SC544-02	D	Fusing heater 2 error
		<ol style="list-style-type: none"> <li>1. During warm-up, fusing thermistor 1 (TH1) does not detect 100°C / 212°F if turning the fusing heater 2 on for 30 seconds continuously.</li> </ol>

SC No.	Type	Error Name/Error Condition/Major Cause/Solution
		<p>2. During warm-up, if turning the fusing heater 2 on for 30 seconds continuously after the temperature detected by the fusing thermistor 1 (TH1) reaches 100°C / 212°F , fusing thermistor 1 (TH1) does not detect the ready state temperature.</p> <ul style="list-style-type: none"> <li>• The fusing thermistor cannot detect the normal temperature with paper strip.</li> <li>• The connector is not properly connected or the wire is faulty.</li> <li>• The normal temperature cannot be detected with the fusing heater not being turned on, broken fusing thermostat wire, etc.</li> <li>• The firmware is not the latest version.</li> <li>• The main/engine PCB (PCB1) is faulty.</li> <li>• The PSU (PCB9) is faulty.</li> <li>• The paper exit PCB (PCB8) is faulty.</li> </ul>
		<ol style="list-style-type: none"> <li>1. Remove a piece of paper remaining in the fusing unit.</li> <li>2. Clean the terminal of the following wire connectors and reconnect the connectors. If there is no continuity, replace the wire. <ul style="list-style-type: none"> <li>• Fusing unit (fusing thermistor) - paper exit PCB (PCB8)</li> <li>• Paper exit PCB (PCB8) - main/engine PCB (PCB1)</li> <li>• PSU (PCB9) - main/engine PCB (PCB1)</li> </ul> </li> <li>3. Replace the fusing unit.</li> <li>4. Upgrade the engine firmware to the latest version</li> <li>5. Replace the main/engine PCB (PCB1).</li> <li>6. Replace the PSU (PCB9) when the fusing heaters always turn on.</li> <li>7. Replace the paper exit PCB (PCB8).</li> </ol>

SC No.	Type	Error Name/Error Condition/Major Cause/Solution
SC544-03	D	Fusing heater high temperature error
		Fusing thermistor 1 (TH1) detected 240 °C / 464 °F for 1 second continuously
		<ul style="list-style-type: none"> <li>• The fusing thermistor cannot detect the normal temperature with paper strip.</li> <li>• The connector is not properly connected or the wire is faulty.</li> <li>• The normal temperature cannot be detected with the fusing heater not being turned on, broken fusing thermostat wire, etc.</li> <li>• The firmware is not the latest version.</li> <li>• The main/engine PCB (PCB1) is faulty.</li> <li>• The PSU (PCB9) is faulty.</li> </ul>
		<ol style="list-style-type: none"> <li>1. Remove a piece of paper remaining in the fusing unit.</li> <li>2. Clean the terminal of the following wire connectors and reconnect the connectors. If there is no continuity, replace the wire. <ul style="list-style-type: none"> <li>• Fusing unit (fusing thermistor) - paper exit PCB (PCB8)</li> </ul> </li> </ol>

## 6.Troubleshooting

SC No.	Type	Error Name/Error Condition/Major Cause/Solution
		<ul style="list-style-type: none"> <li>• Paper exit PCB (PCB8) - main/engine PCB (PCB1)</li> <li>• PSU (PCB9) - main/engine PCB (PCB1)</li> </ul> <ol style="list-style-type: none"> <li>3. Replace the fusing unit.</li> <li>4. Upgrade the engine firmware to the latest version</li> <li>5. Replace the main/engine PCB (PCB1).</li> <li>6. Replace the PSU (PCB9) when the fusing heaters always turn on.</li> </ol>

SC No.	Type	Error Name/Error Condition/Major Cause/Solution
SC547-00	D	Zero-cross signal error
		The zero-cross signal is not input for 1 second continuously when the fusing heater turns on and the 24 V broken wire is not detected.
		<ul style="list-style-type: none"> <li>• The connector is not properly connected or the wire is faulty.</li> <li>• The low voltage PWB is faulty.</li> <li>• The firmware is not the latest version.</li> <li>• The main/engine PWB is faulty.</li> </ul>
		<ol style="list-style-type: none"> <li>1. Clean the terminal of the following wire connectors and reconnect the connectors. If there is no continuity, replace the wire. PSU (PCB9) - main/engine PCB (PCB1)</li> <li>2. Replace the PSU (PCB9) when the fusing heaters always turn on.</li> <li>3. Upgrade the engine firmware to the latest version.</li> <li>4. Replace the main/engine PCB (PCB1).</li> </ol>

SC No.	Type	Error Name/Error Condition/Major Cause/Solution
SC549-00	D	Broken fusing heater 1 error
		<ol style="list-style-type: none"> <li>1. During warm-up, the temperature detected by fusing thermistor 2 (TH2) does not reach 100 °C / 212 °F when passing 20 seconds.</li> <li>2. During warm-up, when passing 30 seconds after the temperature detected by fusing thermistor 2 (TH2) reaches 100 °C / 212 °F , the ready state temperature is not reached.</li> </ol>
		<ul style="list-style-type: none"> <li>• The fusing thermistor cannot detect the normal temperature with paper strip.</li> <li>• The connector is not properly connected or the wire is faulty.</li> <li>• The normal temperature cannot be detected with the fusing heater not being turned on, broken fusing thermostat wire, etc.</li> <li>• The firmware is not the latest version.</li> <li>• The main/engine PCB (PCB1) is faulty.</li> <li>• The PSU (PCB9) is faulty.</li> <li>• The paper exit PCB (PCB8) is faulty.</li> </ul>

SC No.	Type	Error Name/Error Condition/Major Cause/Solution
		<ol style="list-style-type: none"> <li>1. Remove a piece of paper remaining in the fusing unit.</li> <li>2. Clean the terminal of the following wire connectors and reconnect the connectors. If there is no continuity, replace the wire. <ul style="list-style-type: none"> <li>• Fusing unit (fusing thermistor) - paper exit PCB (PCB8)</li> <li>• Paper exit PCB (PCB8) - main/engine PCB (PCB1)</li> <li>• PSU (PCB9) - main/engine PCB (PCB1)</li> </ul> </li> <li>3. Replace the fusing unit.</li> <li>4. Upgrade the engine firmware to the latest version</li> <li>5. Replace the main/engine PCB (PCB1).</li> <li>6. Replace the PSU (PCB9) when the fusing heaters always turn on.</li> <li>7. Replace the paper exit PCB (PCB8).</li> </ol>

SC No.	Type	Error Name/Error Condition/Major Cause/Solution
SC552-00	D	<p>Fusing thermistor 1 (TH1) low temperature error</p> <p>Fusing thermistor 1 (TH1) detects a temperature lower than 100 °C / 212 °F for 1 second in succession during ready or print.</p> <ul style="list-style-type: none"> <li>• The power supply voltage reduces.</li> <li>• The fusing thermistor cannot detect the normal temperature with paper strip.</li> <li>• The connector is not properly connected or the wire is faulty.</li> <li>• The normal temperature cannot be detected with the fusing heater not being turned on, broken fusing thermostat wire, etc.</li> <li>• The firmware is not the latest version.</li> <li>• The main/engine PCB (PCB1) is faulty.</li> <li>• The PSU (PCB9) is faulty.</li> <li>• The paper exit PCB (PCB8) is faulty.</li> </ul> <ol style="list-style-type: none"> <li>1. Connect the power cord to a different wall outlet if the power supply voltage descends by 10% or more of the rated voltage, or multiple devices use the same outlet.</li> <li>2. Remove a piece of paper remaining in the fusing unit.</li> <li>3. Clean the terminal of the following wire connectors and reconnect the connectors. If there is no continuity, replace the wire. <ul style="list-style-type: none"> <li>• Fusing unit (fusing thermistor) - paper exit PCB (PCB8)</li> <li>• Paper exit PCB (PCB8) - main/engine PCB (PCB1)</li> <li>• PSU (PCB9) - main/engine PCB (PCB1)</li> </ul> </li> <li>4. Replace the fusing unit.</li> <li>5. Upgrade the engine firmware to the latest version.</li> <li>6. Replace the main/engine PCB (PCB1).</li> <li>7. Replace the PSU (PCB9) when the fusing heaters always turn on.</li> </ol>

## 6.Troubleshooting

SC No.	Type	Error Name/Error Condition/Major Cause/Solution
		8. Replace the paper exit PCB (PCB8).

SC No.	Type	Error Name/Error Condition/Major Cause/Solution
SC583-00	C	Outer temperature sensor (S8) error
		The sensor input sampling exceeds the reference value. (After detection, controlled at 25 °C / 77.0 °F)
		<ul style="list-style-type: none"> <li>• The connector is not properly connected or the wire is faulty.</li> <li>• The outer temperature sensor (S8) is not properly attached, or it is faulty.</li> <li>• The firmware is not the latest version.</li> <li>• The main/engine PWB is faulty.</li> </ul>
		<ol style="list-style-type: none"> <li>1. Clean the terminal of the following wire connectors and reconnect the connectors. If there is no continuity, replace the wire. Outer temperature sensor (S8) - main/engine PCB (PCB1)</li> <li>2. Reattach the outer temperature sensor (S8). If it is not repaired, replace it.</li> <li>3. Upgrade the engine firmware to the latest version.</li> <li>4. Replace the main/engine PCB (PCB1).</li> </ol>

## Service Call 622-691

### SC600 (Engine: Communication and Others)

SC No.	Type	Error Name/Error Condition/Major Cause/Solution
SC622-01	D	Paper Feed Unit Communication Error (Tray 2)
		A communication error is detected from the paper feed unit 2, 10 times consecutively.
		<ul style="list-style-type: none"> <li>• The paper feed tray is not properly installed.</li> <li>• The connector is not connected properly or, the wire or drawer connector is faulty.</li> <li>• The firmware is not the latest version.</li> <li>• The PF main PCB is faulty.</li> <li>• The engine relay PCB (PCB21) is faulty.</li> </ul>
		<ol style="list-style-type: none"> <li>1. Reinstall the paper feed tray.</li> <li>2. Check the following wire connection, and correct the terminals and reconnect the connectors all the way. If the wire has no continuity or the drawer connector is faulty, replace them. <ul style="list-style-type: none"> <li>• PF lift sensor - PF main PCB</li> <li>• PF lift motor - PF main PCB</li> <li>• PF main PCB - Drawer connector</li> <li>• Drawer connector - engine relay PCB (PCB21)</li> </ul> </li> <li>3. Upgrade the firmware to the latest version.</li> <li>4. Replace the PF main PCB.</li> <li>5. Replace the engine relay PCB (PCB21).</li> </ol>

SC No.	Type	Error Name/Error Condition/Major Cause/Solution
SC622-02	D	Paper Feed Unit Communication Error (Tray 3)
		A communication error is detected from the paper feed unit 3, 10 times consecutively.
		<ul style="list-style-type: none"> <li>• The paper feed tray is not properly installed.</li> <li>• The connector is not connected properly or, the wire or drawer connector is faulty.</li> <li>• The firmware is not the latest version.</li> <li>• The PF main PCB is faulty.</li> <li>• The engine relay PCB (PCB21) is faulty.</li> </ul>
		<ol style="list-style-type: none"> <li>1. Reinstall the paper feed tray.</li> <li>2. Check the following wire connection, and correct the terminals and reconnect the connectors all the way. If the wire has no continuity or the drawer</li> </ol>

## 6.Troubleshooting

SC No.	Type	Error Name/Error Condition/Major Cause/Solution
		<p>connector is faulty, replace them.</p> <ul style="list-style-type: none"> <li>• PF lift sensor - PF main PCB</li> <li>• PF lift motor - PF main PCB</li> <li>• PF main PCB - Drawer connector</li> <li>• Drawer connector - PF main PCB (Tray 2)</li> </ul> <p>3. Upgrade the firmware to the latest version.</p> <p>4. Replace the PF main PCB.</p> <p>5. Replace the engine relay PCB (PCB21).</p>

SC No.	Type	Error Name/Error Condition/Major Cause/Solution
SC622-03	D	Paper Feed Unit Communication Error (Tray 4)
		A communication error is detected from the paper feed unit 4, 10 times consecutively.
		<ul style="list-style-type: none"> <li>• The paper feed tray is not properly installed.</li> <li>• The connector is not connected properly or, the wire or drawer connector is faulty.</li> <li>• The firmware is not the latest version.</li> <li>• The PF main PCB is faulty.</li> <li>• The engine relay PCB (PCB21) is faulty.</li> </ul> <p>1. Reinstall the paper feed tray.</p> <p>2. Check the following wire connection, and correct the terminals and reconnect the connectors all the way. If the wire has no continuity or the drawer connector is faulty, replace them.</p> <ul style="list-style-type: none"> <li>• PF lift sensor - PF main PCB</li> <li>• PF lift motor - PF main PCB</li> <li>• PF main PCB - Drawer connector</li> <li>• Drawer connector - PF main PCB (Tray 3)</li> </ul> <p>3. Upgrade the firmware to the latest version.</p> <p>4. Replace the PF main PCB.</p> <p>5. Replace the engine relay PCB (PCB21).</p>

SC No.	Type	Error Name/Error Condition/Major Cause/Solution
SC665-02	D	Communication error between the main/engine PCB (PCB1) and ASIC
		The checksum error appears or the video signal is not reversed when checking the read-back data after transmitting the data. (Successive failure 10 times)
		<ul style="list-style-type: none"> <li>• The main/engine PCB (PCB1) does not operate correctly.</li> <li>• The connector and FFC are not connected properly or the wire, FFC or PCB is faulty.</li> </ul>

SC No.	Type	Error Name/Error Condition/Major Cause/Solution
		<ol style="list-style-type: none"> <li>1. Turn off the power switch and pull out the power plug. After passing 5 seconds, reinsert the power plug and turn on the power switch.</li> <li>2. Clean the terminal of the connectors on the engine relay PCB (PCB21), reconnect the connector of the wire, and reconnect the FFC terminal. If the wire or the FFC is faulty, repair or replace them. If not resolved, replace the engine relay PCB (PCB21).</li> <li>3. Clean the terminal of the connectors on the main/engine PCB (PCB1), reconnect the connector of the wire, and reconnect the FFC terminal. If the wire or the FFC is faulty, repair or replace them. If not resolved, replace the main/engine PCB (PCB1).</li> </ol>

SC No.	Type	Error Name/Error Condition/Major Cause/Solution
SC665-31	A	<p>Engine firmware unexpected error</p> <ol style="list-style-type: none"> <li>1. The drum motor 1 (M7) drive continued for 60 min. or more while not printing.</li> <li>2. The developer bias turns on while the main charger bias is off. (On for 3,263 ms or more continuously)</li> <li>3. The high voltage remote or main charger DC bias turns on while the drum motor 1 (M7) is stopped. (On for 270 ms or more continuously)</li> <li>4. The periodic writing process to the EEPROM locked for 30 seconds. (The EEPROM writing is not processed for 30 seconds or other priority process occupies (locks) to have no process for the EEPROM.)</li> </ol> <ul style="list-style-type: none"> <li>• The main power start-up is slow.</li> <li>• The firmware is not the latest version.</li> <li>• Main/engine PCB (PCB1) is not attached and connected properly.</li> <li>• Main/engine PCB (PCB1) is faulty.</li> </ul> <ol style="list-style-type: none"> <li>1. Turn the power switch off and unplug the power plug. After 5 seconds, reconnect the power plug and turn the power switch on.</li> <li>2. Upgrade the engine firmware to the latest version.</li> <li>3. Fix main/engine PCB (PCB1) with screws and reconnect the connectors so that the ground is secured.</li> <li>4. Replace main/engine PCB (PCB1).</li> </ol>

SC No.	Type	Error Name/Error Condition/Major Cause/Solution
SC668-00	D	<p>SPI Communication Error</p> <ul style="list-style-type: none"> <li>• The SPI communication error cannot be recovered within 10 seconds after the error occurred.</li> <li>• The error recovery does not finish normally.</li> </ul>

## 6.Troubleshooting

SC No.	Type	Error Name/Error Condition/Major Cause/Solution
		<ul style="list-style-type: none"> <li>• FFC defective or disconnected</li> <li>• BiCU (PCB2) defective</li> <li>• Main/Engine PCB (PCB1) defective</li> </ul>
		<ol style="list-style-type: none"> <li>1. Turn the main power OFF/ON.</li> <li>2. Reconnect the FFC between BiCU (PCB2) and Main/Engine PCB (PCB1).</li> <li>3. Replace the FFC between BiCU (PCB2) and Main/Engine PCB (PCB1).</li> <li>4. Replace the BiCU (PCB2).</li> <li>5. Replace the Main/Engine PCB (PCB1).</li> </ol>

SC No.	Type	Error Name/Error Condition/Major Cause/Solution
SC668-01	D	Main/Engine PCB (PCB1) Startup Error
		The signal to indicate the Main/Engine PCB (PCB1) has started up was not detected within 4 seconds.
		<ul style="list-style-type: none"> <li>• FFC defective or disconnected</li> <li>• Main/Engine PCB (PCB1) defective</li> <li>• BiCU (PCB2) defective</li> </ul>
		<ol style="list-style-type: none"> <li>1. Turn the main power OFF/ON.</li> <li>2. Reconnect the FFC between BiCU (PCB2) and Main/Engine PCB (PCB1).</li> <li>3. Replace the FFC between BiCU (PCB2) and Main/Engine PCB (PCB1).</li> <li>4. Replace the Main/Engine PCB (PCB1).</li> <li>5. Replace the BiCU (PCB2).</li> </ol>

SC No.	Type	Error Name/Error Condition/Major Cause/Solution
SC668-02	D	BiCU (PCB2) – Main/Engine PCB (PCB1) Communication Reset Error
		The communication reset process and error recovery process are not completed properly.
		<ul style="list-style-type: none"> <li>• FFC defective or disconnected</li> <li>• Main/Engine PCB (PCB1) defective</li> <li>• BiCU (PCB2) defective</li> </ul>
		<ol style="list-style-type: none"> <li>1. Turn the main power OFF/ON.</li> <li>2. Reconnect the FFC between BiCU (PCB2) and Main/Engine PCB (PCB1).</li> <li>3. Replace the FFC between BiCU (PCB2) and Main/Engine PCB (PCB1).</li> <li>4. Replace the Main/Engine PCB (PCB1).</li> <li>5. Replace the BiCU (PCB2).</li> </ol>

SC No.	Type	Error Name/Error Condition/Major Cause/Solution
SC668-	D	BiCU (PCB2) – Main/Engine PCB (PCB1) Communication Retry Timeout Error

SC No.	Type	Error Name/Error Condition/Major Cause/Solution
03		The BiCU (PCB2) – Main/Engine PCB (PCB1) communication error cannot be recovered within 10 seconds after the error occurred.
		<ul style="list-style-type: none"> <li>• Main/Engine PCB (PCB1) defective</li> <li>• BiCU (PCB2) defective</li> <li>• FFC defective or disconnected</li> </ul>
		<ol style="list-style-type: none"> <li>1. Turn the main power OFF/ON.</li> <li>2. Replace the Main/Engine PCB (PCB1).</li> <li>3. Replace the BiCU (PCB2).</li> <li>4. Replace the FFC between BiCU (PCB2) and Main/Engine PCB (PCB1).</li> </ol>

SC No.	Type	Error Name/Error Condition/Major Cause/Solution
SC669		EEPROM Communication Error
SC669-01	D	EEPROM OPEN: ID error
SC669-02	D	EEPROM OPEN: Channel error
SC669-03	D	EEPROM OPEN: Device error
SC669-04	D	EEPROM OPEN: Communication abort error
SC669-05	D	EEPROM OPEN: Communication timeout error
SC669-06	D	EEPROM OPEN: Operation stopped error
SC669-07	D	EEPROM OPEN: Buffer full
SC669-08	D	EEPROM OPEN: No error code
SC669-09	D	EEPROM CLOSE: ID error
SC669-10	D	EEPROM CLOSE: No error code
SC669-11	D	EEPROM Data write: ID error
SC669-12	D	EEPROM Data write: Channel error
SC669-13	D	EEPROM Data write: Device error
SC669-14	D	EEPROM Data write: Communication abort error
SC669-15	D	EEPROM Data write: Communication timeout error
SC669-16	D	EEPROM Data write: Operation stopped error
SC669-17	D	EEPROM Data write: Buffer full
SC669-18	D	EEPROM Data write: No error code
SC669-19	D	EEPROM Data read: ID error
SC669-20	D	EEPROM Data read: Channel error
SC669-21	D	EEPROM Data read: Device error
SC669-22	D	EEPROM Data read: Communication abort error
SC669-23	D	EEPROM Data read: Communication timeout error
SC669-24	D	EEPROM Data read: Operation stopped error
SC669-25	D	EEPROM Data read: Buffer full

## 6.Troubleshooting

SC No.	Type	Error Name/Error Condition/Major Cause/Solution
SC669-26	D	EEPROM Data read: No error code
SC669-36	D	Verification error
SC669-37	D	Error Detection
		Communication with the EEPROM failed after retrying <b>N</b> <sup>*1</sup> times. (*1 SC669-01 to 26: 3, SC669-36: 2, SC669-37: 1)
		<ul style="list-style-type: none"> <li>• Electrical noise</li> <li>• EEPROM not installed correctly</li> <li>• EEPROM defective</li> <li>• BiCU (PCB2) defective</li> </ul>
		<ol style="list-style-type: none"> <li>1. Turn the main power OFF/ON.</li> <li>2. Reinstall the EEPROM on the BiCU (PCB2).</li> <li>3. Replace the EEPROM on the BiCU (PCB2).</li> <li>4. Replace the BiCU (PCB2).</li> </ol>

SC No.	Type	Error Name/Error Condition/Major Cause/Solution
SC689-01	D	EEPROM Communication Error 1
		<ul style="list-style-type: none"> <li>• No response from the device in reading/writing for 5 seconds or more and this problem is repeated 5 times.</li> <li>• The reading data of 2 locations does not match 8 times consecutively.</li> <li>• The writing data and reading date does not match 8 times consecutively.</li> </ul>
		EEPROM on the controller board (PCB3) defective
		<ol style="list-style-type: none"> <li>1. Turn the main power OFF and wait for 5 seconds. Then turn ON the main power.</li> <li>2. Check whether the EEPROM on the controller board (PCB3) is installed correctly. If necessary, reinstall it.</li> <li>3. Replace the controller board (PCB3).</li> <li>4. If the EEPROM on the controller board (PCB3) is damaged, replace the EEPROM.</li> </ol>

SC No.	Type	Error Name/Error Condition/Major Cause/Solution
SC689-02	D	EEPROM device error (main/engine PCB (PCB1))
		Data from the EEPROM cannot be read at start-up (3 times retries)
		<ul style="list-style-type: none"> <li>• EEPROM (main/engine PCB (PCB1)) is faulty.</li> <li>• The connector and FFC are not connected properly or the wire, FFC or PCB is faulty.</li> </ul>
		<ol style="list-style-type: none"> <li>1. Turn off the power switch and pull out the power plug. After passing 5 seconds, reinsert the power plug and turn on the power switch.</li> </ol>

SC No.	Type	Error Name/Error Condition/Major Cause/Solution
		2. Clean the terminal of the connectors on the main/engine PCB (PCB1), reconnect the connector of the wire, and reconnect the FFC terminal. If the wire or the FFC is faulty, repair or replace them. If not resolved, replace the main/engine PCB (PCB1).

SC No.	Type	Error Name/Error Condition/Major Cause/Solution
SC690-00	C	EEPROM Data Error
		Reading data from EEPROM is abnormal.
		<ul style="list-style-type: none"> <li>• The EEPROM does not operate properly.</li> <li>• The EEPROM is faulty.</li> </ul>
		<ol style="list-style-type: none"> <li>1. Turn off the power switch and pull out the power plug. After passing 5 seconds, reinsert the power plug and turn on the power switch.</li> <li>2. Replace the EEPROM on the main/engine PCB (PCB1) and execute initialization.</li> </ol>

SC No.	Type	Error Name/Error Condition/Major Cause/Solution
SC691-00	D	Image Processing Error
		The print sequence jam is detected 2 times in succession.
		<ul style="list-style-type: none"> <li>• The image data is faulty.</li> <li>• The printing operation of the certain file is faulty.</li> <li>• The connector and FFC are not connected properly or the wire, FFC or PCB is faulty.</li> </ul>
		<ol style="list-style-type: none"> <li>1. When this issue occurs only when handling the certain image data, check if the image data is faulty.</li> <li>2. Acquire the job's log if the phenomenon can be reproduced by specifying the job when the error was detected.</li> <li>3. Clean the terminal of the connectors on the main/engine PCB (PCB1), reconnect the connector of the wire, and reconnect the FFC terminal. If the wire or the FFC is faulty, repair or replace them. If not resolved, replace the main/engine PCB (PCB1).</li> </ol>

---

### SC600 (Controller)

---

SC No.	Type	Error Name/Error Condition/Major Cause/Solution
SC670-01	D	Engine does not start up during the starting up
		<ul style="list-style-type: none"> <li>• /ENGRDY signal was not asserted when the machine was turned on.</li> <li>• PCI I/F is not linked up when the machine returns from energy saver mode.</li> <li>• EC/PC/SC response was not received within specified time from power on.</li> </ul>

## 6.Troubleshooting

SC No.	Type	Error Name/Error Condition/Major Cause/Solution
		<ul style="list-style-type: none"> <li>• Writing to Rapi driver failed (the other party not found through PCI).</li> <li>• Connection defect between controller board (PCB3) and BiCU (PCB2).</li> <li>• BiCU (PCB2) is down / unstable</li> </ul>
		Main/engine PCB (PCB1) does not start up.
		Refer to <a href="#">SC670 (engine startup error) is displayed.</a>

SC No.	Type	Error Name/Error Condition/Major Cause/Solution
SC670-02	D	Engine does not start up after the starting up
		<ul style="list-style-type: none"> <li>• CPU reset by software</li> <li>• CPU reset by anomaly CPU</li> <li>• CPU reset by hardware defect / noise</li> <li>• Hardware defect</li> </ul>
		Main/engine PCB (PCB1) reset unexpectedly.
		Refer to <a href="#">SC670 (engine startup error) is displayed.</a>

SC No.	Type	Error Name/Error Condition/Major Cause/Solution
SC670-03	D	BiCU (PCB2) start up error when the machine boots up
		VDET_EPCI signal was not asserted when the machine was turned on.
		<ul style="list-style-type: none"> <li>• BiCU (PCB2), PSU (PCB9), and/or controller board (PCB3) defective</li> <li>• Incorrect connection between controller board (PCB3) and BiCU (PCB2).</li> <li>• Harness of BiCU (PCB2) disconnected</li> </ul>
		Refer to <a href="#">SC670 (engine startup error) is displayed.</a>

SC No.	Type	Error Name/Error Condition/Major Cause/Solution
SC670-04	D	Communication error between the engine and controller
		Communication could not linked up.
		<ul style="list-style-type: none"> <li>• BiCU (PCB2) and/or controller board (PCB3) defective</li> <li>• Incorrect connection between controller board (PCB3) and BiCU (PCB2).</li> </ul>
		Refer to <a href="#">SC670 (engine startup error) is displayed.</a>

## Service Call 816-899

### SC800 (Controller)

No.	Type	Error Name/Error Condition/Major Cause/Solution
SC816-**	[0x0000]	Energy save I/O subsystem error
SC816-01	D	Subsystem error
SC816-02	D	Sysarch (LPUX_GET_PORT_INFO) error
SC816-03	D	Transition to STR was denied.
SC816-04	D	Interrupt in kernel communication driver
SC816-05	D	Preparation for transition to STR failed.
SC816-07	D	Sysarch (LPUX_GET_PORT_INFO) error
SC816-08	D	Sysarch (LPUX_ENGINE_TIMERCTRL) error
SC816-09	D	Sysarch (LPUX_RETURN_FACTOR_STR) error
SC816-10 to 12	D	Sysarch (LPUX_GET_PORT_INFO) error
SC816-13	D	open() error
SC816-14	D	Memory address error
SC816-15 to 18	D	open() error
SC816-19	D	Double open() error
SC816-20	D	open() error
SC816-22	D	Parameter error
SC816- 23, 24	D	read() error
SC816-25	D	write () error
SC816-26 to 28	D	write() communication retry error
SC816- 29, 30	D	read() communication retry error
SC816-35	D	read() error
SC816-36 to 96	D	Subsystem error
SC 816- 98	D	Subsystem error
		Energy save I/O subsystem detected some abnormality.
		<ul style="list-style-type: none"> <li>• Energy save I/O subsystem defective</li> <li>• Energy save I/O subsystem detected a controller board (PCB3) error (non-response).</li> </ul>

## 6.Troubleshooting

No.	Type	Error Name/Error Condition/Major Cause/Solution
		<ul style="list-style-type: none"> <li>Error was detected during preparation for transition to STR.</li> <li>SC816-99 occurs as a subsystem error except any error from -06 to 96.</li> </ul>
		<p>Check if the SC occurs by turning the power OFF then ON. If the SC occurs again, do the following steps. Check if the SC reoccurs by cycling the power after each step.</p> <ol style="list-style-type: none"> <li>Update the "System" firmware and the other system firmware to the latest version.</li> <li>Disable the STR shift function by SP5-191-001 (Power Str Set).</li> <li>Replace the controller board (PCB3).</li> </ol>

No.	Type	Error Name/Error Condition/Major Cause/Solution
SC819-00	D	<p>Kernel halt error [xxxx]: Detailed error code</p> <p>Due to a control error, a RAM overflow occurred during system processing. One of the following messages was displayed on the operation panel.</p>
	[0x5032]	<p>HAIC-P2 error</p> <p>HAIC-P2 decompression error (An error occurred in the ASIC compression/decompression module.)</p> <ul style="list-style-type: none"> <li>The code data saved in the HDD was broken for an unexpected reason. (HDD device defective)</li> <li>The code data saved to memory was broken for an unexpected reason. (Memory device defective)</li> <li>ASIC defective</li> <li>Data other than code data was unzipped due to a software malfunction.</li> </ul> <ul style="list-style-type: none"> <li>Turn the main power OFF/ON.</li> <li>Replace the HDD.</li> <li>Replace the memory</li> <li>Replace the controller board (PCB3).</li> <li>Fix the software</li> </ul>
	[0x5245]	<p>Link up error</p> <p>Link up transaction between Engine ASIC and Veena was not completed within 100 ms.</p> <p>Either one of following message appears on console if Link up error occurs. RESUME:PCI-Express bus ROOT_DL status error RESUME:PCI-Express bus DETUP status error "0x53554D45" -&gt; Link up error Also, error code "0x5245" and detail code ""0x53554D45" -&gt; Link up error"</p>

No.	Type	Error Name/Error Condition/Major Cause/Solution
		appears on operation panel.
		<ul style="list-style-type: none"> <li>• Turn the main power OFF/ON.</li> <li>• Replace the controller board (PCB3) or the BiCU (PCB2).</li> </ul>
	[0x5355]	L2 status time out
		L2 status register between Engine ASIC and Veena was not reached the target value within 1 sec.
		Engine ASIC during operation was rebooted or shifted to energy saving mode.
		Machine reboots when SC23x, SC30x occurs.
		If Engine ASIC is working when rebooting (or shifting to the energy saving mode), L2 status value is not on target.
		The following message appears on console.
		SUSPEND:PCI-Express L2 Status Check Error
		Also, error code "0x5355" and detail code ""0x5350454E44" -> L2 status time out" appears on operation panel.
		<ul style="list-style-type: none"> <li>• Turn the main power OFF/ON.</li> <li>• Replace the controller board (PCB3) or the BiCU (PCB2).</li> </ul>
	[0x6261]	HDD defective
		Received file system data was broken even if the initialization succeeds and there was no error reply from the HDD.
		Power supply disconnection during data writing to the HDD.
		Replace the HDD.
		This SC may occur when turning on the machine for the first time with a new HDD. In this case, turn the main power OFF/ON.
	[0x696e]	gwinit processing end
		If the SCS process is ended for some reason
		If an unexpected error occurs at SCS processing end, gwinit processing also halts (this result is judged a kernel stop error, by gwinit specification)
		"0x69742064" -> "init died"
		Turn the main power OFF/ON.
	[0x766d]	VM full error
		Occurs when too much RAM is used during system processing
		"vm_pageout: VM is full"
		Turn the main power OFF/ON.
	Console string	Other error (characters on operation panel)
		System detected internal mismatch error
		<ul style="list-style-type: none"> <li>• Software defective</li> </ul>

## 6.Troubleshooting

No.	Type	Error Name/Error Condition/Major Cause/Solution
		<ul style="list-style-type: none"> <li>• Insufficient memory</li> <li>• Hardware driver defective (RAM, flash memory, CPU)</li> </ul>
		<ul style="list-style-type: none"> <li>• Replace with a larger capacity RAM, or flash memory.</li> <li>• Replace the controller board (PCB3).</li> <li>• Replace the connected controller option with a new one.</li> </ul>

No.	Type	Error Name/Error Condition/Major Cause/Solution
SC840-00	D	EEPROM access error
		<ul style="list-style-type: none"> <li>• During the I/O processing, a reading error occurred. The 3rd reading failure causes this SC code.</li> <li>• During the I/O processing, a writing error occurred.</li> </ul>
		<ul style="list-style-type: none"> <li>• Defective EEPROM</li> </ul>
		-

No.	Type	Error Name/Error Condition/Major Cause/Solution
SC841-00	D	EEPROM read data error
		Mirrored data of the EEPROM is different from the original data in EEPROM.
		Data in the EEPROM is overwritten for some reason.
		-

No.	Type	Error Name/Error Condition/Major Cause/Solution
SC842-00	C	Nand-Flash updating verification error
		SCS write error (verify error) occurred at the Nand-Flash module when remote ROM or main ROM was updated.
		Nand-Flash defective
		Turn the main power OFF/ON.

No.	Type	Error Name/Error Condition/Major Cause/Solution
SC842-01	C	Insufficient Nand-Flash blocks (threshold exceeded)
		At startup, or when machine returned from energy save mode, the Nand-Flash status was read and judged that the number of unusable blocks had exceeded threshold, and then SCS generated the SC code.
		Number of unusable blocks exceeded threshold for Nand-Flash
		Replace the controller board (PCB3).

No.	Type	Error Name/Error Condition/Major Cause/Solution
SC842-	C	Number of Nand-Flash block deletions exceeded

No.	Type	Error Name/Error Condition/Major Cause/Solution
02		At startup, or when the machined returned from energy save mode, the Nand-Flash was read and judged that the number of deleted blocks had exceeded threshold, and then SCS generated this SC code.
		Number of blocks deleted exceeded threshold for Nand-Flash.
		Replace the controller board (PCB3).

No.	Type	Error Name/Error Condition/Major Cause/Solution
SC845		Hardware Error Detected when the automatic firmware update
SC845-01	D	Main/Engine PCB (PCB1)
SC845-02	D	Controller Board (PCB3)
SC845-03	D	Operation Panel (Normal)
		When updating the firmware automatically (ARFU), the firmware cannot be read or written normally, and the firmware update cannot be completed even by 3 retries.
		Hardware abnormality of the target board
		Replace the target board. For SC845-02, HDD and memory may cause the problem. Replace the HDD or memory if the SC cannot be recovered by replacing the controller board (PCB3).

No.	Type	Error Name/Error Condition/Major Cause/Solution
SC855-01	B	Wireless LAN board error (driver attachment failure)
		Wireless LAN board error (wireless LAN card: 802.11 is covered)
		<ul style="list-style-type: none"> <li>• Defective wireless LAN board</li> <li>• Loose connection</li> </ul>
		<ul style="list-style-type: none"> <li>• Turn the main power OFF/ON.</li> <li>• Replace wireless LAN board</li> </ul>

No.	Type	Error Name/Error Condition/Major Cause/Solution
SC855-02	B	Wireless LAN board error (driver initialization failure)
		Wireless LAN board error (wireless LAN card: 802.11 is covered)
		<ul style="list-style-type: none"> <li>• Defective wireless LAN board</li> <li>• Loose connection</li> </ul>
		<ul style="list-style-type: none"> <li>• Turn the main power OFF/ON.</li> <li>• Replace wireless LAN board</li> </ul>

## 6.Troubleshooting

No.	Type	Error Name/Error Condition/Major Cause/Solution
SC857-00	B	USB I/F Error
		The USB interface is unusable because of a driver error.
		USB driver error (There are three causes of USB error: RX error/CRC error/STALL. SC is issued only in the case of STALL.)
		<ul style="list-style-type: none"> <li>• Check USB connection.</li> <li>• Replace the controller board (PCB3).</li> </ul>

No.	Type	Error Name/Error Condition/Major Cause/Solution
SC860-00	B	HDD startup error at main power on (HDD error)
		<ul style="list-style-type: none"> <li>• The HDD is connected but the driver detected the following errors.</li> <li>• SS_NO.T_READY:/* (-2)HDD does not become READY*/</li> <li>• SS_BAD_LABEL:/* (-4)Wrong partition type*/</li> <li>• SS_READ_ERROR:/* (-5)Error occurred while reading or checking the label*/</li> <li>• SS_WRITE_ERROR:/* (-6)Error occurred while writing or checking the label*/</li> <li>• SS_FS_ERROR:/* (-7)Failed to repair the filesystem*/</li> <li>• SS_MOUNT_ERROR:/* (-8)Failed to mount the filesystem*/</li> <li>• SS_COMMAND_ERROR:/* (-9)Drive not responding to command*/</li> <li>• SS_KERNEL_ERROR:/* (-10)Internal kernel error*/</li> <li>• SS_SIZE_ERROR:/* (-11)Drive size too small*/</li> <li>• SS_NO._PARTITION:/* (-12)The specified partition does not exist*/</li> <li>• SS_NO._FILE:/* (-13)Device file does not exist*/</li> <li>• Attempted to acquire HDD status through the driver but there has been no response for 30 seconds or more.</li> </ul>
		<ul style="list-style-type: none"> <li>• Unformatted HDD</li> <li>• Label data corrupted</li> <li>• HDD defective</li> </ul>
		Format the HDD (SP5-832: HDD formatting) through SP mode.

SC No.	Type	Error Name/Error Condition/Major Cause/Solution
SC860-01	D	HDD file system error at power on (HDD error)
		Even one partition mount of HDD failed
		<ul style="list-style-type: none"> <li>• Power off during file writing to HDD</li> <li>• Shutting down while writing the file to HDD</li> </ul>
SC860-02	D	HDD label error (HDD error)
		HDD partition information is abnormal
		<ul style="list-style-type: none"> <li>• Power off during HDD initialization</li> </ul>

SC No.	Type	Error Name/Error Condition/Major Cause/Solution
		<ul style="list-style-type: none"> <li>HDD defective</li> </ul>
SC860-03	D	HDD encryption key error (HDD error)
		HDD encryption key could not be read with HDD encryption
		Simultaneous breakage of the controller's ROM (NAND) and NVRAM
		<ol style="list-style-type: none"> <li>Power cycle the machine.</li> <li>Format the HDD with SP5-832-001.</li> <li>Replace the HDD.</li> </ol>

No.	Type	Error Name/Error Condition/Major Cause/Solution
SC863-01	D	HDD data read failure
		The data written to the HDD cannot be read normally.
		Bad sectors were generated during operation. (An error occurred in an area that does not belong to a partition, such as the disk label area.)
		<p>Guide for when to replace the HDD</p> <ol style="list-style-type: none"> <li>When SC863 has occurred ten times or more <ul style="list-style-type: none"> <li>The interval is short.</li> <li>Repeatedly occurs in the same situation (At power-on, etc.).</li> <li>Startup takes a long time when the main power is turned ON.</li> </ul> </li> <li>It takes a long time after main power on for the operation panel to become ready. HDD access may be consuming time. Normal HDD access time after main power on is about 5 seconds. If the machine is not waiting for the engine to be ready and it still takes 20 to 30 seconds or more, the HDD may be the cause. If there is a problem with the HDD, HDD-related SCs such as SC860 and SC863 will occur frequently. Print the SC log data and check them.</li> </ol>

No.	Type	Error Name/Error Condition/Major Cause/Solution
SC863-02 to 23	D	HDD data read failure
		The data written to the HDD cannot be read normally.
		Bad sectors were generated during operation. (An error occurred in partition "a" (SC863-02) to partition "v" (SC863-23)).
		<p>Guide for when to replace the HDD</p> <ol style="list-style-type: none"> <li>When SC863 has occurred ten times or more <ul style="list-style-type: none"> <li>The interval is short.</li> <li>Repeatedly occurs in the same situation (At power-on, etc.).</li> <li>Startup takes a long time when the main power is turned ON.</li> </ul> </li> </ol>

## 6.Troubleshooting

No.	Type	Error Name/Error Condition/Major Cause/Solution
		<p>2. It takes a long time after main power on for the operation panel to become ready.</p> <p>HDD access may be consuming time. Normal HDD access time after main power on is about 5 seconds. If the machine is not waiting for the engine to be ready and it still takes 20 to 30 seconds or more, the HDD may be the cause. If there is a problem with the HDD, HDD-related SCs such as SC860 and SC863 will occur frequently. Print the SC log data and check them.</p>

No.	Type	Error Name/Error Condition/Major Cause/Solution
SC864-01	D	HDD data CRC error
		During HDD operation, the HDD cannot respond to a CRC error query. Data transfer did not execute normally while data was being written to the HDD.
		Bad sectors were generated during operation. (An error occurred in an area that does not belong to a partition, such as the disk label area.)
		<ul style="list-style-type: none"> <li>• Format the HDD.</li> <li>• Replace the HDD.</li> </ul>

No.	Type	Error Name/Error Condition/Major Cause/Solution
SC864-02 to 23	D	HDD data CRC error
		During HDD operation, the HDD cannot respond to a CRC error query. Data transfer did not execute normally while data was being written to the HDD.
		Bad sectors were generated during operation. (An error occurred in partition "a" (SC864-02) to partition "v" (SC864-23)).
		<ul style="list-style-type: none"> <li>• Format the HDD.</li> <li>• Replace the HDD.</li> </ul>

No.	Type	Error Name/Error Condition/Major Cause/Solution
SC865-00	D	HD access error
		During HDD operation, the HDD returned an error.
		The HDD returned an error that does not constitute SC863 (bad sector) or SC864 (CRC error).
		Replace the HDD.

No.	Type	Error Name/Error Condition/Major Cause/Solution
SC865-01	D	HDD access error
		During HDD operation, the HDD returned an error.

No.	Type	Error Name/Error Condition/Major Cause/Solution
		The HDD returned an error that does not constitute SC863 (bad sector) or SC864 (CRC error). (An error occurred in an area that does not belong to a partition, such as the disk label area.)
		Replace the HDD.

No.	Type	Error Name/Error Condition/Major Cause/Solution
SC865-02 to 23	D	HDD access error
		During HDD operation, the HDD returned an error.
		The HDD returned an error that does not constitute SC863 (bad sector) or SC864 (CRC error). (An error occurred in partition "a" (SC865-02) to partition "v" (SC865-23)).
		Replace the HDD.

No.	Type	Error Name/Error Condition/Major Cause/Solution
SC865-50 to 73	D	HDD time-out error
		The machine does not detect a reply from the HDD during the HDD operation.
		The HDD does not respond to the read/ write command from the machine.
		<ul style="list-style-type: none"> <li>• Check the harness connections between the controller board (PCB3) and HDD.</li> <li>• Replace the HDD.</li> </ul>

No.	Type	Error Name/Error Condition/Major Cause/Solution
SC866-00	B	SD card authentication error
		A license error of an application that is started from the SD card was detected.
		Invalid program data is stored on the SD card.
		Store a valid program data on the SD card.

No.	Type	Error Name/Error Condition/Major Cause/Solution
SC867-00	C	SD card removed
		The SD card was removed while the machine is on.
		An application SD card has been removed from the slot (mount point of /mnt/sd0).
		Turn the main power OFF/ON.

## 6.Troubleshooting

No.	Type	Error Name/Error Condition/Major Cause/Solution
SC867-01	C	SD card removed
		The SD card was removed while the machine is on.
		An application SD card has been removed from the slot (mount point of /mnt/sd1).
		Turn the main power OFF/ON.

No.	Type	Error Name/Error Condition/Major Cause/Solution
SC867-02	C	SD card removed
		The SD card was removed while the machine is on.
		An application SD card has been removed from the slot (mount point of /mnt/sd2).
		Turn the main power OFF/ON.

No.	Type	Error Name/Error Condition/Major Cause/Solution
SC868-**		SD card access error
SC868-00	D	The SD controller returned an error during operation. (An error occurred at the mount point of /mnt/sd0)
SC868-01	D	The SD controller returned an error during operation. (An error occurred at the mount point of /mnt/sd1)
SC868-02	D	The SD controller returned an error during operation. (An error occurred at the mount point of /mnt/sd1)
		<ul style="list-style-type: none"> <li>• SD card defective</li> <li>• SD controller defective</li> </ul>
		Slot number is displayed on the sub code. Detail code is described in SMC print can confirm the details of the error. <ul style="list-style-type: none"> <li>• -13 to -3: File system check error</li> <li>• Otherwise (no code, -2) : Device access error</li> </ul>
		<p><b>SD card that starts an application</b></p> <ol style="list-style-type: none"> <li><b>1.</b> Turn the main power OFF and check the SD card insertion status.</li> <li><b>2.</b> If no problem is found, insert the SD card and turn the main power ON.</li> <li><b>3.</b> If an error occurs, replace the SD card.</li> <li><b>4.</b> If the error persists even after replacing the SD card, replace the controller board (PCB3).</li> </ol> <p><b>SD card for users</b></p> <ol style="list-style-type: none"> <li><b>1.</b> In case of a file system error, reformat the SD card (using the "SD Formatter" made by Panasonic).*</li> </ol>

No.	Type	Error Name/Error Condition/Major Cause/Solution
		<p><b>In case of a device access error</b></p> <ol style="list-style-type: none"> <li><b>1.</b> Turn the main power OFF and check the SD card insertion status.</li> <li><b>2.</b> If no problem is found, insert the SD card and turn the main power ON.</li> <li><b>3.</b> If an error occurs, use another SD card.</li> <li><b>4.</b> If the error persists even after replacing the SD card, replace the controller board (PCB3).</li> </ol>

\* Do not format an SD card supplied with the main machine or sold as an option. You may only format SD cards used for Firmware Update by a service representative.

No.	Type	Error Name/Error Condition/Major Cause/Solution
SC874-05	D	Delete all error (Delete data area) : Read error
SC874-06	D	Delete all error (Delete data area) : Write error
SC874-09	D	Delete all error (Delete data area) : No response from HDD
SC874-10	D	Delete all error (Delete data area) : Error in Kernel
SC874-12	D	Delete all error (Delete data area) : No designated partition
SC874-13	D	Delete all error (Delete data area) : No device file
SC874-14	D	Delete all error (Delete data area) : Start option error
SC874-15	D	Delete all error (Delete data area) : No designated sector number
SC874-16	D	Delete all error (Delete data area) : Failure in performing hdderase
SC874-41	D	Delete all error (Delete data area) : Other fatal errors
SC874-42	D	Delete all error (Delete data area) : End by cancellation
SC874-61 to -65	D	Delete all error (Delete data area) : library error
SC874-66	D	Delete all error (Delete data area) : Unavailable
SC874-67	D	Delete all error (Delete data area) : Erasing not finished
SC874-68	D	Delete all error (Delete data area) : HDD format failure (Normal)
SC874-69	D	Delete all error (Delete data area) : HDD format failure (Abnormal)
SC874-99	D	Delete all error (Delete data area) : other errors
		<p>An error occurred while data was being erased on HDD or NVRAM.</p> <ul style="list-style-type: none"> <li>• Error detected in HDD data delete program</li> <li>• Error detected in NVRAM data delete program</li> <li>• The "Delete All" option was not set</li> </ul> <p>• Turn the main power OFF and back on, and then execute "Erase All Memory" under UP mode again. (However, if there is a defective sector or other problem with the hard disk, the error will persist even after trying the above.)</p> <ul style="list-style-type: none"> <li>• If the "Delete All" option is not installed when this error occurs, install the</li> </ul>

## 6.Troubleshooting

No.	Type	Error Name/Error Condition/Major Cause/Solution
		option.

No.	Type	Error Name/Error Condition/Major Cause/Solution
SC875-01	D	Delete all error (HDD erasure) (hddchack -i error)
SC875-02	D	Delete all error (HDD erasure) (Data deletion failure)
		An error was detected before HDD/data erasure starts. (Failed to erase data/failed to logically format HDD)
		<ul style="list-style-type: none"> <li>HDD logical formatting failed.</li> <li>The modules failed to erase data.</li> </ul>
		Turn the main power OFF/ON.

No.	Type	Error Name/Error Condition/Major Cause/Solution
SC877-00	B	Data Overwrite Security card error
		The "Auto Erase Memory" function of the Data Overwrite Security is set to on but it cannot be done.
		<ul style="list-style-type: none"> <li>Data Overwrite Security option SD card is broken.</li> <li>Data Overwrite Security option SD card has been removed.</li> </ul>
		<ul style="list-style-type: none"> <li>If the SD card is broken, prepare a new Data Overwrite Security option SD card and replace the NVRAM.</li> <li>If the SD card has been removed, turn the main power off and reinstall a working Data Overwrite Security option SD card.</li> </ul>

No.	Type	Error Name/Error Condition/Major Cause/Solution
SC878-00	D	TPM authentication error
		TPM electronic recognition failure
		<ul style="list-style-type: none"> <li>Update of system module attempted without correct update path</li> <li>USB flash memory not operating correctly</li> </ul>
		Replace the controller board (PCB3).

### Trusted Platform Module

- In computing, Trusted Platform Module (TPM) is both the name of a published specification detailing a secure crypto processor that can store cryptographic keys that protect information, as well as the general name of implementations of that specification often called the "TPM chip" or "TPM Security Device" (as designated in certain Dell BIOS settings).

No.	Type	Error Name/Error Condition/Major Cause/Solution
SC878-01	D	USB flash error

No.	Type	Error Name/Error Condition/Major Cause/Solution
		There is a problem in the file system of the USB flash memory.
		USB Flash system files corrupted.
		Replace the controller board (PCB3).

No.	Type	Error Name/Error Condition/Major Cause/Solution
SC878-02	D	TPM error
		An error occurred in either TPM or the TPM driver.
		TPM not operating correctly.
		Replace the controller board (PCB3).

No.	Type	Error Name/Error Condition/Major Cause/Solution
SC878-03	D	TCSD error
		An error occurred in the TPM software stack.
		<ul style="list-style-type: none"> <li>• TPM, TPM software cannot start</li> <li>• A file required by TPM is missing</li> </ul>
		Replace the controller board (PCB3).

No.	Type	Error Name/Error Condition/Major Cause/Solution
SC878-20	D	Random number generator self check error
		The unusual status is detected during the self test of generated random number seed.
		TPM defective. (The random number seed is generated by TPM)
		<ol style="list-style-type: none"> <li>1. Turn ON the main power.</li> <li>2. Replace the controller board (PCB3).</li> </ol>

No.	Type	Error Name/Error Condition/Major Cause/Solution
SC899-00	D	Software performance error (signal reception end)
		Unknown software error occurred.
		Occurs when an internal program behaves abnormally.
		In the case of a hardware defect <ul style="list-style-type: none"> <li>• Replace the hardware.</li> </ul> In the case of a software error <ul style="list-style-type: none"> <li>• Turn the main power OFF/ON.</li> <li>• Try updating the firmware.</li> </ul>

## Service Call 900-998

### SC900 (Controller)

SC No.	Type	Error Name/Error Condition/Major Cause/Solution
SC900-00	A	Electric counter error
		The electric total counter value is out of specification. Error is detected when increasing the total counter.
		<ul style="list-style-type: none"> <li>• Unexpected NV-RAM is attached.</li> <li>• NV-RAM defective</li> <li>• NV-RAM data corrupted.</li> <li>• Data written to unexpected area because of external factor etc.</li> <li>• The count requested by the SRM on receiving PRT is not completed.</li> </ul>
		Replace the NV-RAM.

SC No.	Type	Error Name/Error Condition/Major Cause/Solution
SC920-02	B	Printer error (WORK memory not acquired)
		When an error is detected in the application, which makes continued operation impossible.
		<ul style="list-style-type: none"> <li>• Software bug</li> <li>• Unexpected hardware configuration (such as insufficient memory)</li> </ul>
		<ul style="list-style-type: none"> <li>• Turn the main power off/on.</li> <li>• Increase the memory storage capacity.</li> </ul>

SC No.	Type	Error Name/Error Condition/Major Cause/Solution
SC920-04	B	Printer error (Filter process not started)
		When an error is detected in the application, which makes continued operation impossible.
		<ul style="list-style-type: none"> <li>• Software bug</li> <li>• Unexpected hardware configuration (such as insufficient memory)</li> </ul>
		<ul style="list-style-type: none"> <li>• Turn the main power off/on.</li> </ul>

SC No.	Type	Error Name/Error Condition/Major Cause/Solution
SC921-00	B	Printer error (Resident font not found)
		Resident font was not found at printer startup
		Preinstalled font files not found.
		Turn the main power off/on.

SC No.	Type	Error Name/Error Condition/Major Cause/Solution
SC990-00	D	Software operation error
		Software attempted an unexpected operation.
		<ul style="list-style-type: none"> <li>Parameter error</li> <li>Internal parameter error</li> <li>Insufficient work memory</li> <li>Operation error caused by abnormalities that are normally undetectable.</li> </ul>
		<ul style="list-style-type: none"> <li>Turn the main power OFF/ON.</li> <li>Reinstall the software of the controller board (PCB3) and BiCU (PCB2).</li> </ul>

SC No.	Type	Error Name/Error Condition/Major Cause/Solution
SC991-00	C	Recoverable software operation error
		Software attempted an unexpected operation. SC991 covers recoverable errors as opposed to CS990.
		<ul style="list-style-type: none"> <li>Parameter error</li> <li>Internal parameter error</li> <li>Insufficient work memory</li> <li>Operation error caused by abnormalities that are normally undetectable.</li> </ul>
		Logging only

SC No.	Type	Error Name/Error Condition/Major Cause/Solution
SC992-00	D	Undefined SC issued.
		An SC, that is not controlled by the system, occurred.
		<ul style="list-style-type: none"> <li>An SC for the previous model was used mistakenly, etc.</li> <li>Basically a software bug.</li> </ul>
		Turn the main power OFF/ON.

SC No.	Type	Error Name/Error Condition/Major Cause/Solution
SC994-00	C	Operation error caused by abnormalities that are normally undetectable.
		An error occurred because the number of records exceeded the limit for images managed in the service layer of the firmware.
		This can occur if there are too many application screens open on the operation panel.
		Logging only.

SC No.	Type	Error Name/Error Condition/Major Cause/Solution
SC998-00	D	Application start error
		<ul style="list-style-type: none"> <li>No application was registered to system within a specified time after the main</li> </ul>

## 6.Troubleshooting

SC No.	Type	Error Name/Error Condition/Major Cause/Solution
		<p data-bbox="459 246 742 280">power was turned ON.</p> <p data-bbox="459 295 1356 329">(No application starts/All applications have been terminated abnormally)</p> <ul style="list-style-type: none"> <li data-bbox="402 344 1232 378">• Application started but cannot be drawn now for some reason.</li> </ul> <hr/> <ul style="list-style-type: none"> <li data-bbox="402 394 925 427">• Software bug (mainly the application)</li> <li data-bbox="402 443 1428 521">• The optional RAM/DIMM/boards, required by the application program, are not installed correctly.</li> </ul> <hr/> <ul style="list-style-type: none"> <li data-bbox="402 537 1399 571">• Check the optional RAM/DIMM/boards required by the application program.</li> <li data-bbox="402 586 1236 620">• Check if the combination of downloaded programs are correct.</li> <li data-bbox="402 636 920 669">• Replace the controller board (PCB3).</li> </ul>

## Jam Detection

### Paper Jam Display

SP7-507 shows the paper jam history.

```
CODE :011
SIZE :05h
TOTAL:000034
DATE :Fri Feb 15 11:44:50 2006
```

- CODE: Indicates the jam code.
- SIZE: Indicates the paper Size Code.
- TOTAL: Indicates the total counter (SP7-502-001).
- DATE: indicates the date when the jam occurred.

#### Note

- The 10 latest printer jams are displayed.
- Initial jams are not recorded.

### Jam Codes and Display Codes

An error message appears if a paper misfeed occurs. The error message indicates where the misfeed occurs.

SP7-504 shows how many jams occurred at each location.

Jam Code	Description	Indication on the operation panel
001	Bypass transport sensor (S6)	D
001	Registration sensor (S1)	A
001	Paper feed sensor 1 (Tray 2)	Y1
001	Paper end sensor 2 (Tray 3)	Y2
001	Paper end sensor 3 (Tray 4)	Y3
001	Exit sensor	B
001	Duplex sensor (S5)	Z
010	Unit package won't become ready.	-
011	Transfer unit not ready.	-
012	Drive does not stop.	-
013	Duplex printing signal doesn't come.	Z
014	Fusing unit not ready.	-
015	Tray 2 feeding signal doesn't come.	A
016	Rear cover open jam	-
017	Upper cover open jam	-

## 6.Troubleshooting

Jam Code	Description	Indication on the operation panel
019	Tray 1: No feed	E
020	Duplex unit: No feed	Z
021	Bypass tray: No feed	C
022	Tray 1: Multiple feed	A
023	Tray 2: Multiple feed	Y1
024	Tray 3: Multiple feed	Y2
025	Tray 4: Multiple feed	Y3
026	Duplex unit: Multiple feed	A
027	Bypass tray: Multiple feed	D
028	Paper feed sensor 2: Late jam (When paper feed from Tray 3)	B
029	Paper feed sensor 2: Late jam (When paper feed from Tray 4)	B
030	Paper feed sensor 2: Lag jam (When paper feed from Tray 3)	Y2
031	Paper feed sensor 2: Lag jam (When paper feed from Tray 4)	Y2
032	Paper feed sensor 3: Late jam (When paper feed from Tray 4)	B
033	Paper feed sensor 3: Lag jam (When paper feed from Tray 4)	Y3
034	Registration sensor (S1): Late jam (When paper feed from Tray 2)	A
035	Registration sensor (S1): Late jam (When paper feed from Tray 3)	A
036	Registration sensor (S1): Late jam (When paper feed from Tray 4)	A
037	Registration sensor (S1): Late jam (When paper feed from bypass tray)	A
038	Registration sensor (S1): Lag jam (When paper feed from Tray 2)	A
039	Registration sensor (S1): Lag jam (When paper feed from Tray 3)	A
040	Registration sensor (S1): Lag jam (When paper feed from Tray 4)	A
041	Registration sensor (S1): Lag jam (When paper feed	A

Jam Code	Description	Indication on the operation panel
	from bypass tray)	
042	Exit sensor: Late jam (When paper feed from Tray 1)	A
043	Exit sensor: Late jam (When paper feed from Tray 2)	A
044	Exit sensor: Late jam (When paper feed from Tray 3)	A
045	Exit sensor: Late jam (When paper feed from Tray 4)	A
046	Exit sensor: Late jam (When paper feed from duplex unit)	A
047	Exit sensor: Late jam (When paper feed from bypass tray unit)	A
048	Exit sensor: Lag jam (When paper feed from Tray 1)	B
049	Exit sensor: Lag jam (When paper feed from Tray 2)	B
050	Exit sensor: Lag jam (When paper feed from Tray 3)	B
051	Exit sensor: Lag jam (When paper feed from Tray 4)	B
052	Exit sensor: Lag jam (When paper feed from duplex unit)	B
053	Exit sensor: Lag jam (When paper feed from bypass tray unit)	B
054	Duplex sensor (S5): Late jam (When paper feed from Tray 1)	Z
055	Duplex sensor (S5): Late jam (When paper feed from Tray 2)	Z
056	Duplex sensor (S5): Late jam (When paper feed from Tray 3)	Z
057	Duplex sensor (S5): Late jam (When paper feed from Tray 4)	Z
058	Duplex sensor (S5): Late jam (When paper feed from bypass tray unit)	Z
059	Duplex sensor (S5): Lag jam (When paper feed from Tray 1)	Z
060	Duplex sensor (S5): Lag jam (When paper feed from Tray 2)	Z
061	Duplex sensor (S5): Lag jam (When paper feed from Tray 3)	Z
062	Duplex sensor (S5): Lag jam (When paper feed from Tray 4)	Z
063	Duplex sensor (S5): Lag jam (When paper feed from bypass tray unit)	Z
099	Tray 2: No feed	Y1

## 6. Troubleshooting

Jam Code	Description	Indication on the operation panel
100	Cover was opened while feeding from Tray 2.	-
101	Tray 3: No feed	Y2
102	Cover was opened while feeding from Tray 3.	-
103	Tray 4: No feed	Y3
104	Cover was opened while feeding from Tray 4.	-

## Sensor Layout

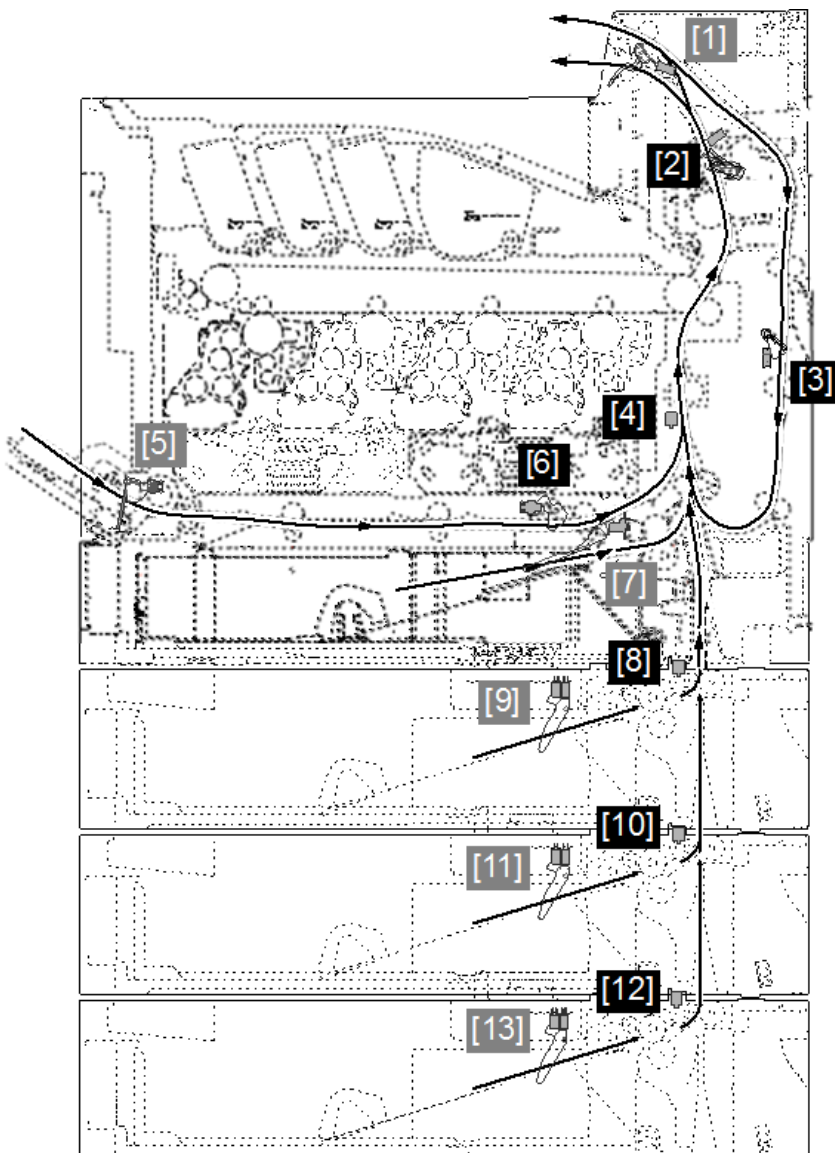

m0cja0255

No.	Name	No.	Name
1	Paper full sensor	8	PF paper feed sensor 1
2	Exit sensor	9	PF paper sensor 1
3	Duplex sensor (S5)	10	PF paper feed sensor 2

No.	Name	No.	Name
4	Registration sensor (S1)	11	PF paper sensor 2
5	Bypass paper sensor (S7)	12	PF paper feed sensor 3
6	Bypass transport sensor (S6)	13	PF paper sensor 3
7	Paper sensor		

## Paper Size Codes

Paper size codes are as follows.

\* The unit of Main Scan/Sub Scan Length is 0.1 mm.

Size Code	Paper Size Name	Orientation	Main Scan Length	Sub Scan Length
133(85H)	A4	SEF	2100	2970
134(86H)	A5	SEF	1480	2100
006(06H)	A5	LEF	2100	1480
135(87H)	A6	SEF	1050	1480
142(8EH)	B5	SEF	1820	2570
143(8FH)	B6	SEF	1280	1820
164(A4H)	8 1/2"x14"(LG)	SEF	2159	3556
165(A5H)	8 1/2"x13"(Foolscap)	SEF	2159	3302
166(A6H)	8 1/2"x11"(LT)	SEF	2159	2794
167(A7H)	8 1/4"x14"	SEF	2096	3556
168(A8H)	8 1/4"x13"(Folio)	SEF	2096	3302
169(A9H)	8"x13" (F/GL)	SEF	2032	3302
171(ABH)	8"x10" (UK)	SEF	2032	2540
173(ADH)	7 1/4"x10 1/2"(Executive)	SEF	1842	2667
172(ACH)	5 1/2"x8 1/2"(HLT)	SEF	1397	2159
208(D0H)	No.10 (Com10)	SEF	1048	2413
209(D1H)	No.7 (Monarch)	SEF	984	1905
211(D3H)	C5 Envelope	SEF	1620	2290
212(D4H)	C6 Envelope	SEF	1140	1620
213(D5H)	DL	SEF	1100	2200
195(C3H)	16K	SEF	1950	2670
200(C8H)	8.5"x13.4"(Oficio)	SEF	2159	3404

## SC670 (engine startup error) is displayed

### Cause

The engine board resets at an unexpected time, and does not start up again.

This occurs in the priority order of SC670-03 > 04 > 05 > 01 > 02.

### Solution

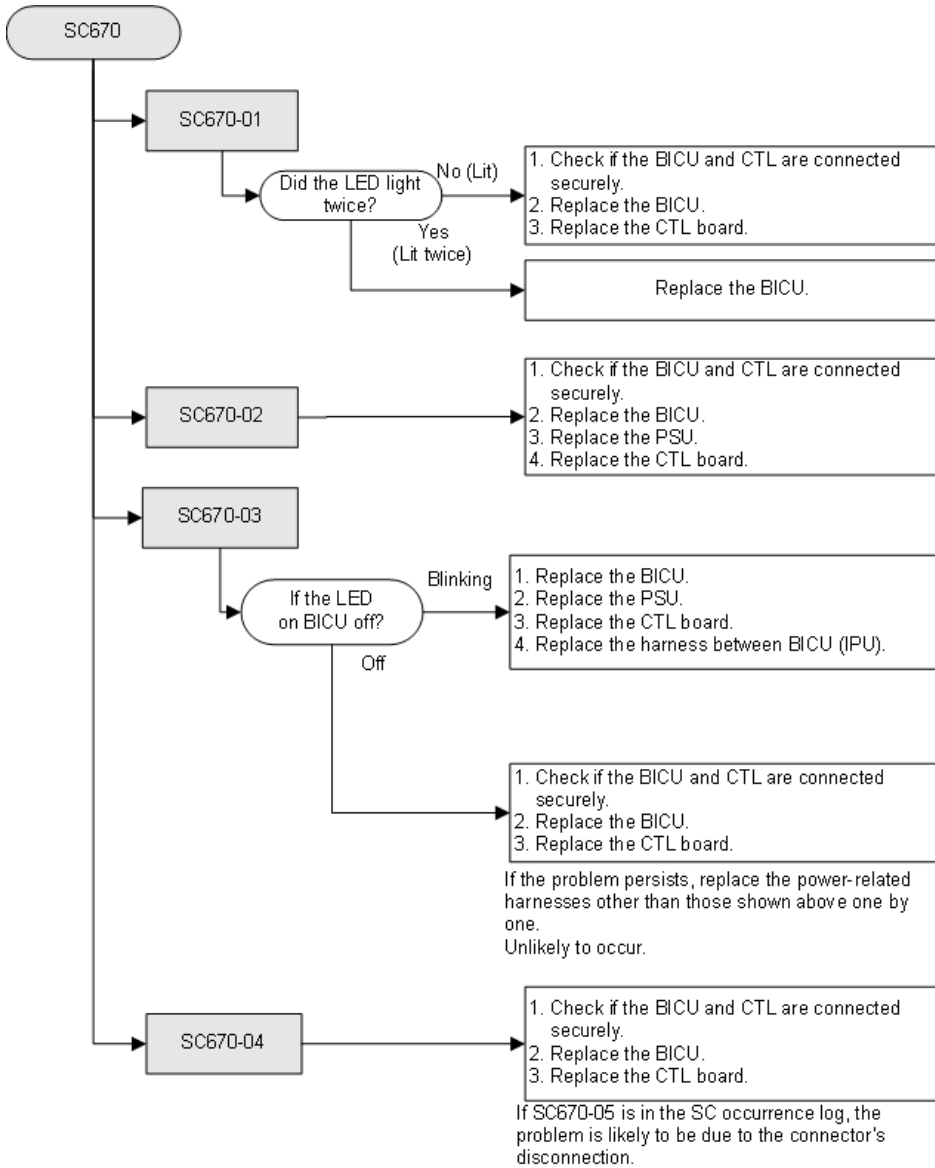

# 7. Detailed Descriptions

## Product Overview

### Component Layout / Paper Path

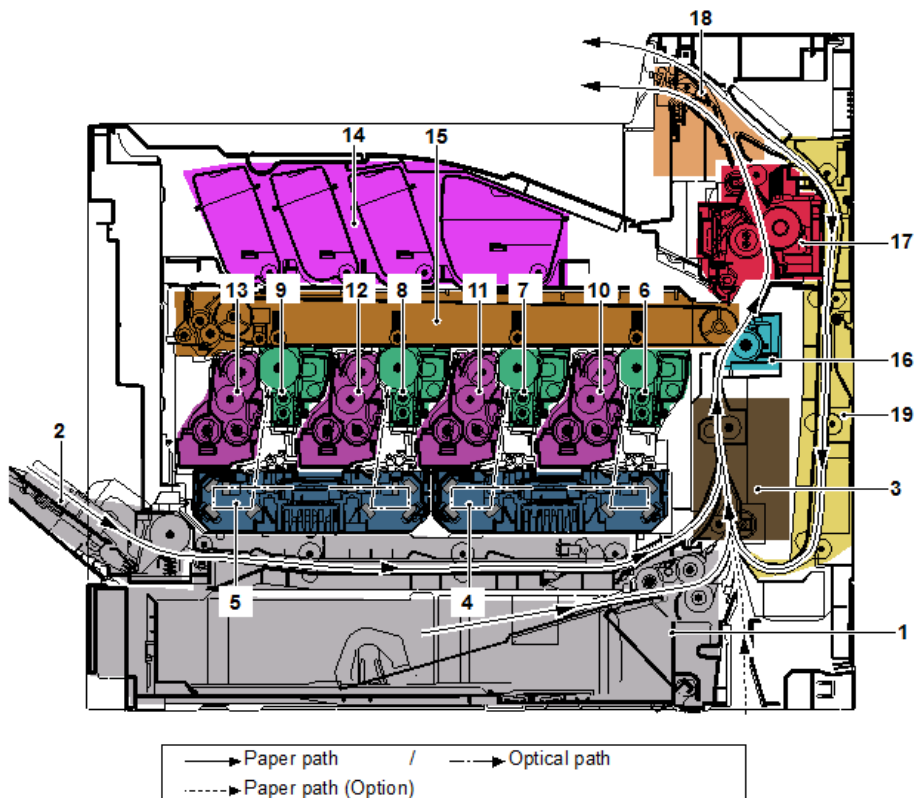

w\_m0cja0010\_en

No.	Name	No.	Name
1	Cassette paper feed section	11	Developer unit M
2	Bypass paper feed section	12	Developer unit C
3	Paper conveying section	13	Developer unit Y
4	Laser scanner unit KM	14	Toner cartridges
5	Laser scanner unit CY	15	ITB unit
6	Drum unit K	16	Paper transfer and separation section
7	Drum unit M	17	Fusing unit
8	Drum unit C	18	Feedshift and exit section
9	Drum unit Y	19	Duplex conveying section
10	Developer unit K		

Parts Layout

PCBs

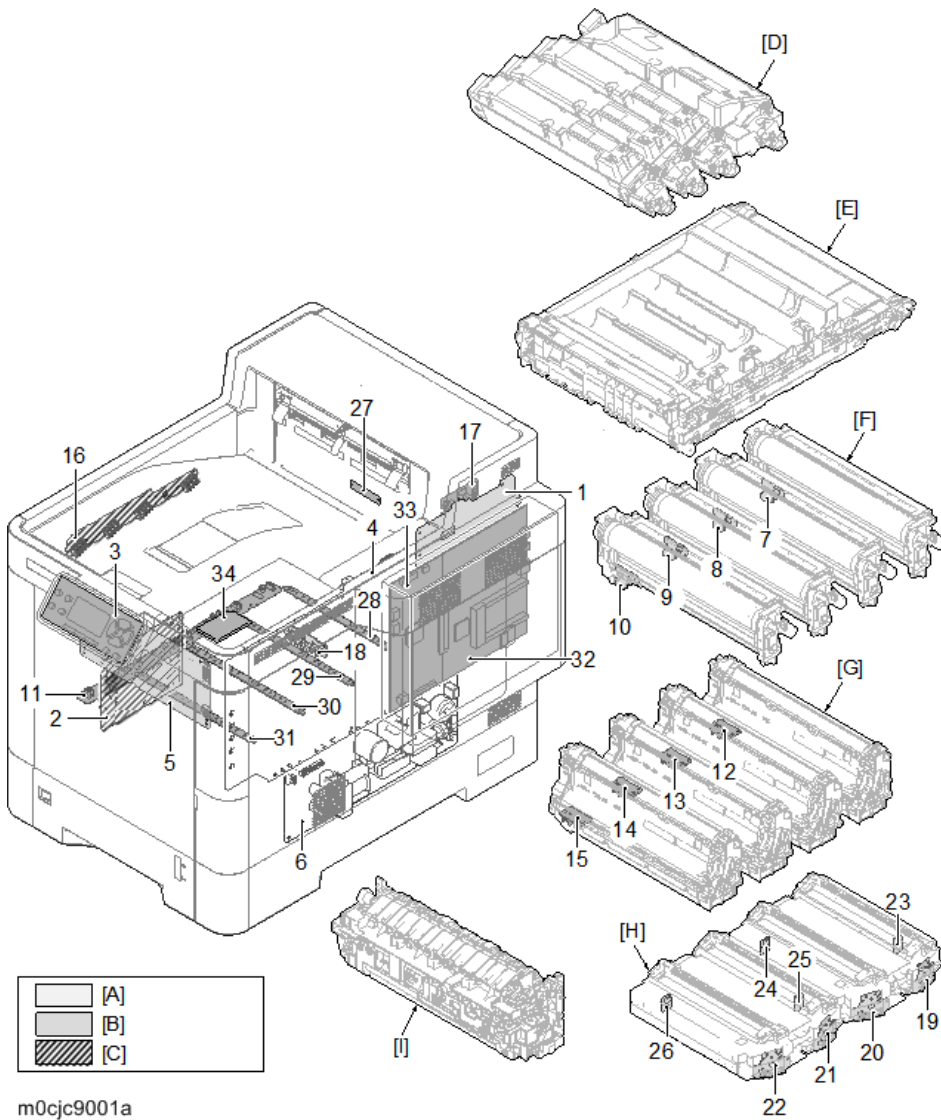

- [A]: Machine Right
- [B]: Machine Inner
- [C]: Machine Left
- [D]: Toner cartridge (K, M, C, Y)
- [E]: ITB unit
- [F]: Drum unit (K, M, C, Y)
- [G]: Development unit (K, M, C, Y)
- [H]: Laser unit (KM, CY)
- [I]: Fusing unit

No.	Name	No.	Name
1	Main/Engine PCB (PCB1)	18	Cassette PCB (PCB25)
2	Engine relay PCB (PCB21)	19	LDB K (PCB18)

## 7.Detailed Descriptions

No.	Name	No.	Name
3	OPU Board	20	LDB M (PCB16)
4	HVP (PCB19)	21	LDB C (PCB14)
5	HVP 2 (PCB20)	22	LDB Y (PCB12)
6	PSU (PCB9)	23	Synchronizing Detector Board K (PCB17)
7	Drum PCB (PCB23) K	24	Synchronizing Detector Board M (PCB15)
8	Drum PCB (PCB23) M	25	Synchronizing Detector Board C (PCB13)
9	Drum PCB (PCB23) C	26	Synchronizing Detector Board Y (PCB11)
10	Drum PCB (PCB23) Y	27	Fusing zener PCB (PCB10)
11	Drum relay PCB (PCB22)	28	Drum heater K PCB
12	Developer PCB (PCB24) K	29	Drum heater M PCB
13	Developer PCB (PCB24) M	30	Drum heater C PCB
14	Developer PCB (PCB24) C	31	Drum heater Y PCB
15	Developer PCB (PCB24) Y	32	Controller Board (PCB3)
16	Toner cartridge relay PCB (PCB26)	33	BiCU (PCB2)
17	Paper exit PCB (PCB8)	34	NFC Board (PCB4)

## 7.Detailed Descriptions

### Sensors and Switches

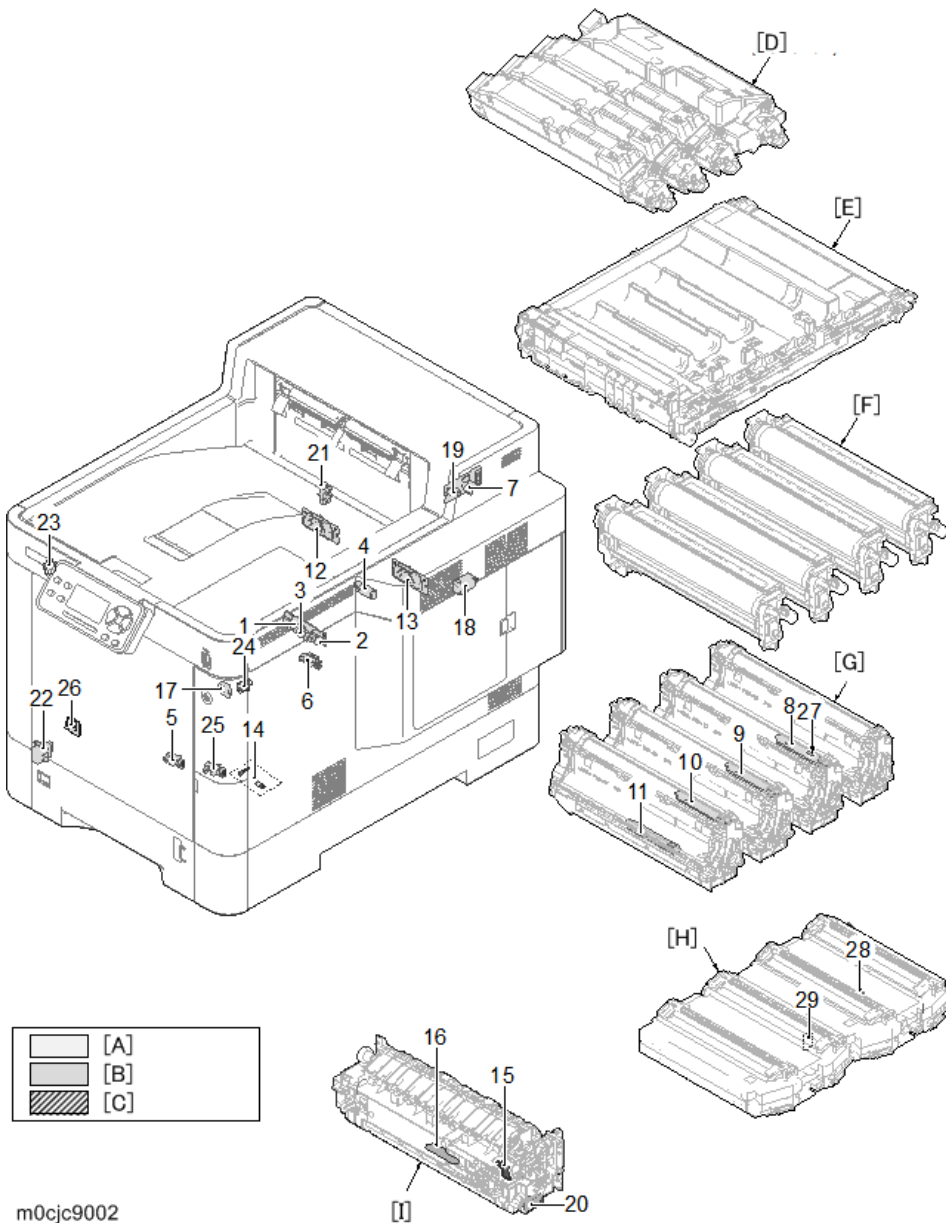

m0cjc9002

[A]: Machine Right

[B]: Machine Inner

[C]: Machine Left

[D]: Toner cartridge (K, M, C, Y)

[E]: ITB unit

[F]: Drum unit (K, M, C, Y)

[G]: Development unit (K, M, C, Y)

[H]: Laser unit (KM, CY)

[I]: Fusing unit

No.	Name	No.	Name
1	Paper sensor 1	16	Fusing thermistor 2 (TH2)
2	Paper sensor 2	17	Power switch (SW5)

## 7.Detailed Descriptions

No.	Name	No.	Name
3	Lift sensor	18	Interlock switch (SW1)
4	Registration sensor (S1)	19	Paper full sensor
5	Bypass paper sensor (S7)	20	Press-release sensor (S2)
6	Bypass transport sensor (S6)	21	Duplex sensor (S5)
7	Exit sensor	22	Cassette size switch (SW4)
8	Toner sensor (S9) K	23	Exit tray switch (SW2)
9	Toner sensor (S9) M	24	Toner cartridge switch (SW3)
10	Toner sensor (S9) C	25	Waste toner cover sensor (S3)
11	Toner sensor (S9) Y	26	Outer temperature sensor (S8)
12	ID sensor 1 (PCB6)	27	Developer thermistor (TH5)
13	ID sensor 2 (PCB7)	28	Laser unit thermistor KM (TH3)
14	Waste toner sensor (S4)	29	Laser unit thermistor CY (TH4)
15	Fusing thermistor 1 (TH1)		

## 7.Detailed Descriptions

### Motors

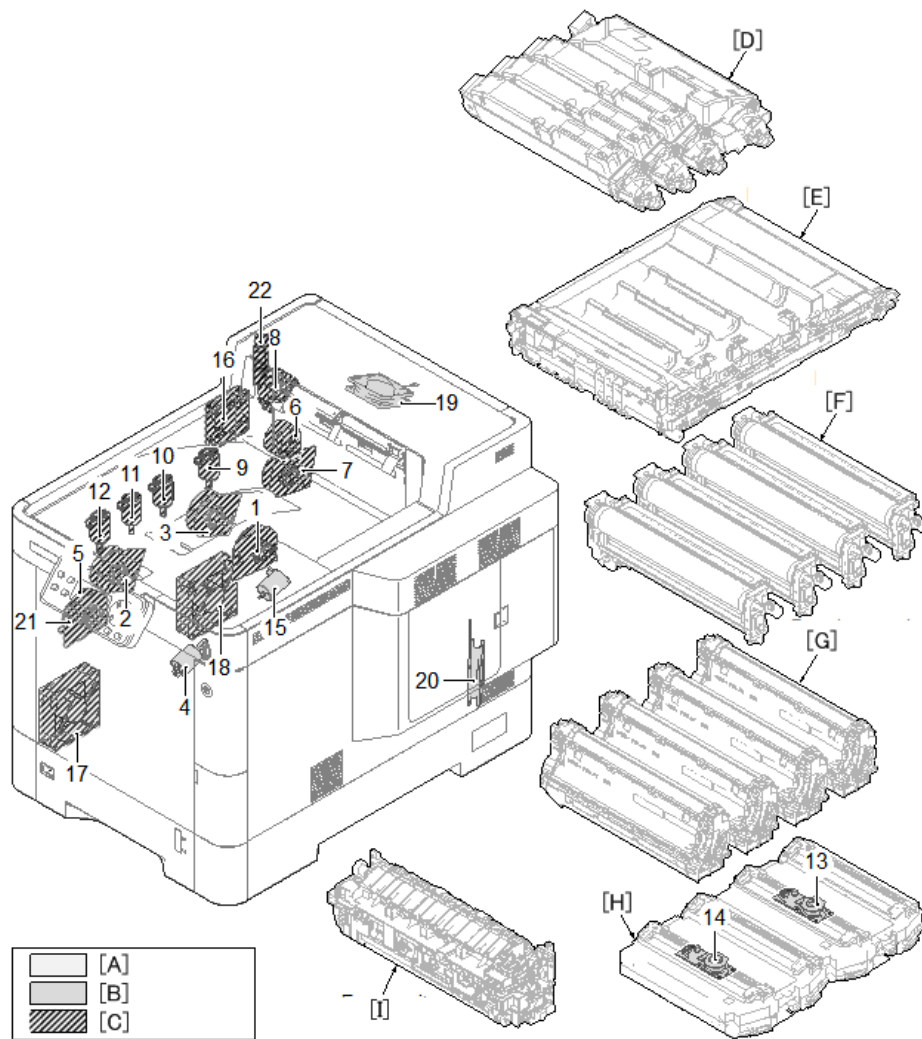

m0cjc9003

[A]: Machine Right

[B]: Machine Inner

[C]: Machine Left

[D]: Toner cartridge (K, M, C, Y)

[E]: ITB unit

[F]: Drum unit (K, M, C, Y)

[G]: Development unit (K, M, C, Y)

[H]: Laser unit (KM, CY)

[I]: Fusing unit

No.	Name	No.	Name
1	Transport developer motor (M4)	12	Toner motor (M11) Y
2	Drum motor 1 (M7)	13	Polygon motor (M1) KM
3	Drum motor 2 (M8)	14	Polygon motor (M1) CY
4	Lift motor (M9)	15	Laser unit cleaning motor (M10)
5	Developer motor (M5)	16	Cartridge fan motor (FAN3)

No.	Name	No.	Name
6	Fusing motor (M2)	17	Laser unit fan motor 1 (FAN5)
7	Image transfer motor (M6)	18	Laser unit fan motor 2 (FAN6)
8	Duplex exit motor (M3)	19	Exit fan motor (FAN7)
9	Toner motor (M11) K	20	Power supply fan motor (FAN1)
10	Toner motor (M11) M	21	Transfer fan motor (FAN4)
11	Toner motor (M11) C	22	Duplex fan motor (FAN2)

Clutches and Solenoids and other parts

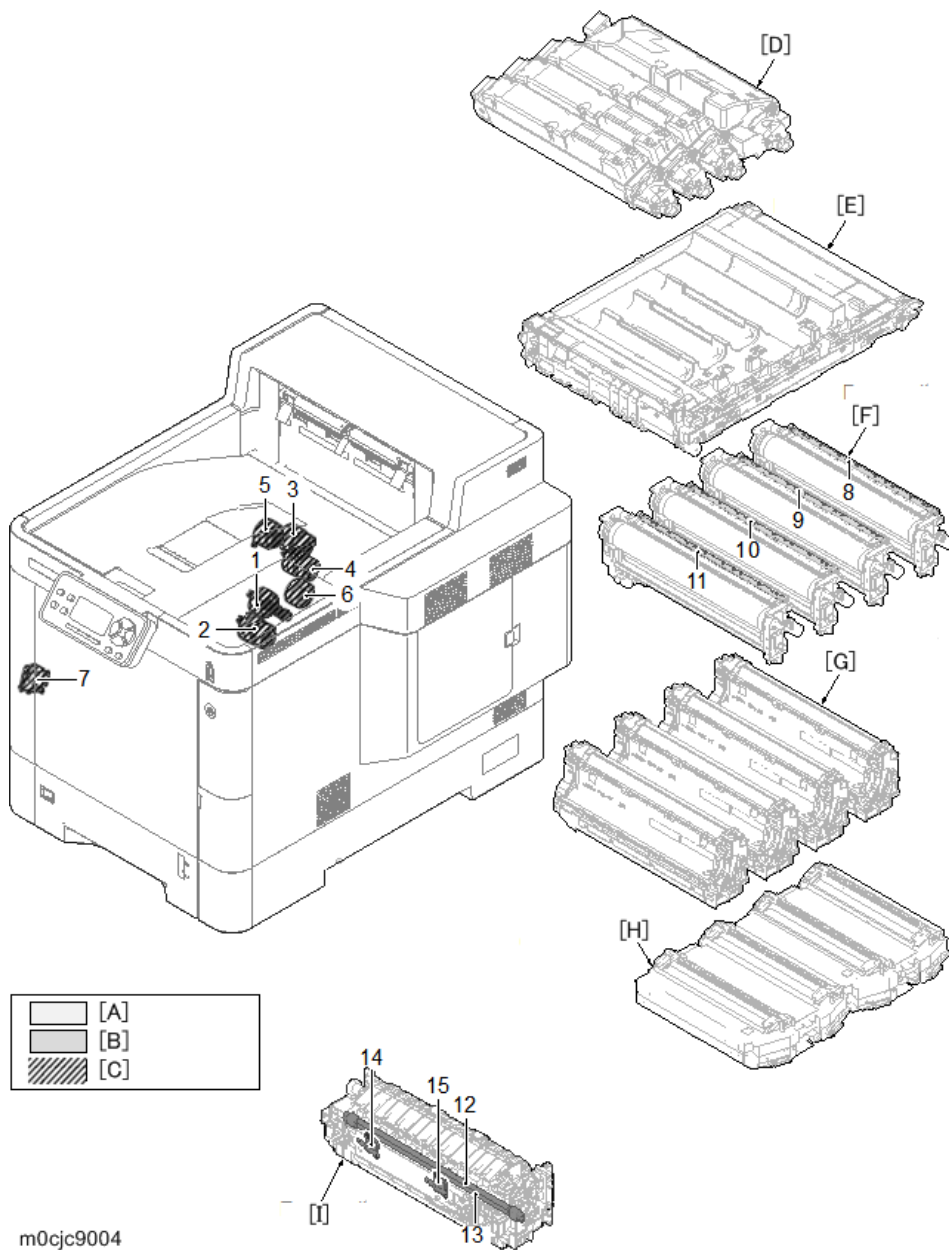

m0cjc9004

- [A]: Machine Right
- [B]: Machine Inner
- [C]: Machine Left

## 7.Detailed Descriptions

[D]: Toner cartridge (K, M, C, Y)

[E]: ITB unit

[F]: Drum unit (K, M, C, Y)

[G]: Development unit (K, M, C, Y)

[H]: Laser unit (KM, CY)

[I]: Fusing unit

No.	Name	No.	Name
1	Paper feed clutch (CL2)	9	Cleaning lamp M
2	Bypass transport clutch (CL3)	10	Cleaning lamp C
3	Registration clutch	11	Cleaning lamp Y
4	Middle clutch (CL4)	12	Fusing heater 1
5	Developer clutch (CL5)	13	Fusing heater 2
6	Duplex clutch (CL1)	14	Fusing thermostat 1
7	Bypass solenoid (SOL1)	15	Fusing thermostat 2
8	Cleaning lamp K		

## Laser Unit

The charged drum surface is scanned by the laser emitted from the laser scanner units. The laser reflects to the polygon mirrors by rotating the polygon motor (M1) so that the laser scans horizontally to the image. The laser scanner unit has some lenses and mirrors, that adjust the diameter of the laser to focus the laser to the drum surface. Also, the laser unit cleaning motor (M10) operates to automatically clean the laser unit glass.

No.	Name	No.	Name
1	Polygon motor (M1)	6	Mirror B
2	Polygon mirror	7	Mirror C
3	f-theta lens A	8	Laser unit glass
4	f-theta lens B	9	Spiral
5	Mirror A		

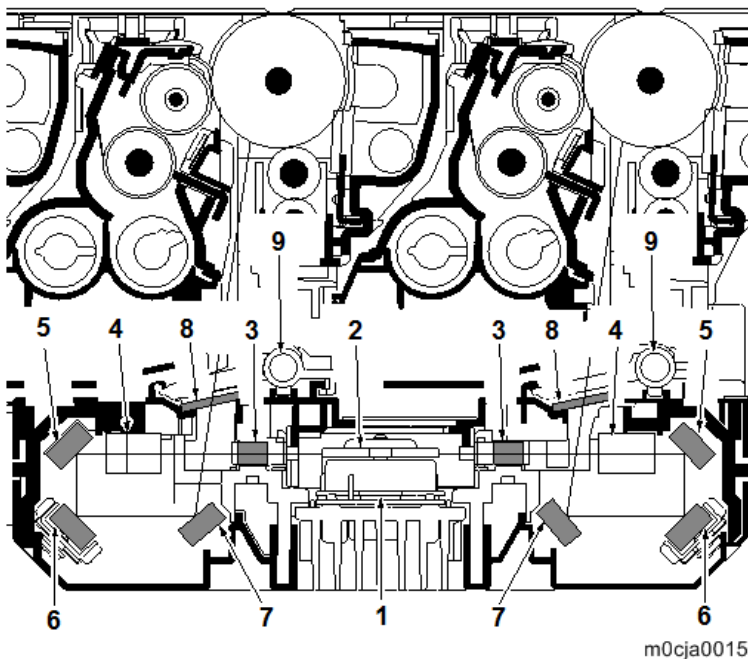

## 7.Detailed Descriptions

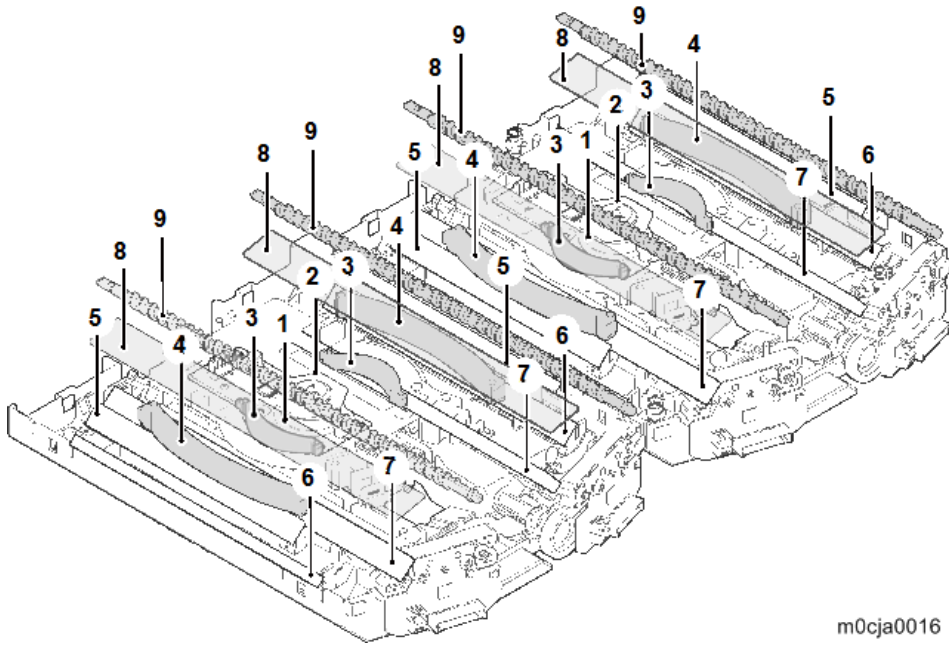

m0cja0016

## Development Unit

The development unit consists of the magnet roller forming the magnetic brush, the sleeve roller forming the thin layer by replacing the toner, the developer blade, and the developer screw mixing up the toner. The toner density is adjusted by impressing the bias to the magnet roller and the sleeve roller. The toner amount inside the developer unit is detected by the toner sensor (S9).

No.	Name	No.	Name
1	Sleeve roller	6	Developer case
2	Magnet roller	7	Developer top cover
3	Developer screw A	8	Developer base
4	Developer screw B	9	Toner sensor (S9)
5	Developer blade		

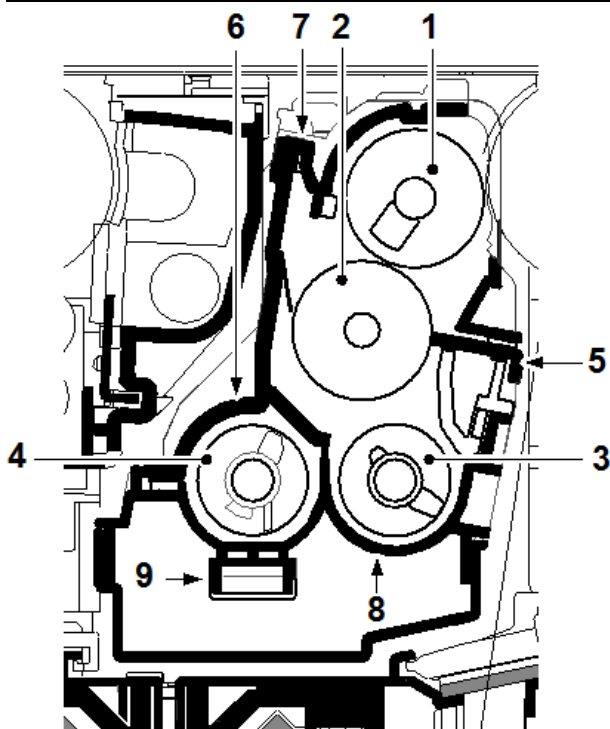

m0cja0017

## 7.Detailed Descriptions

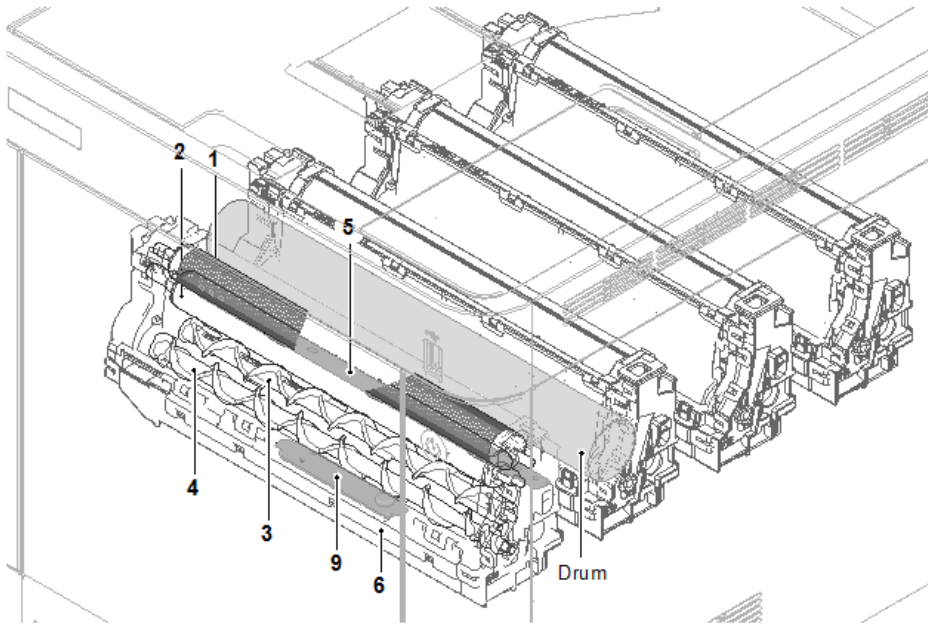

w\_m0cja0018\_en

## Drum Unit

The drum section consists of the drum, the charger roller unit, and the cleaning unit. The drum surface is evenly charged to prepare forming the electrical latent image by emitting the laser.

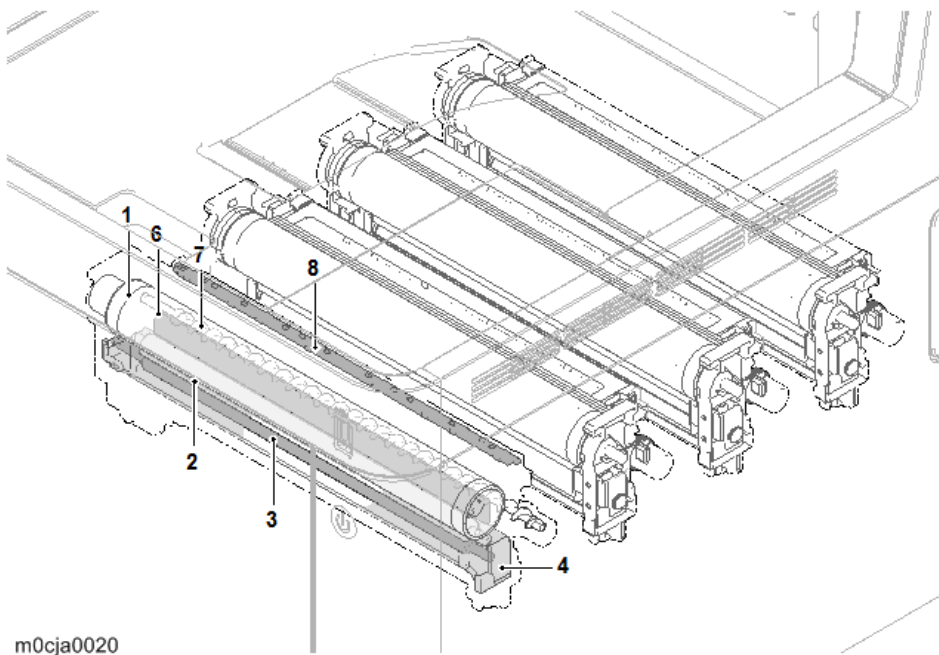
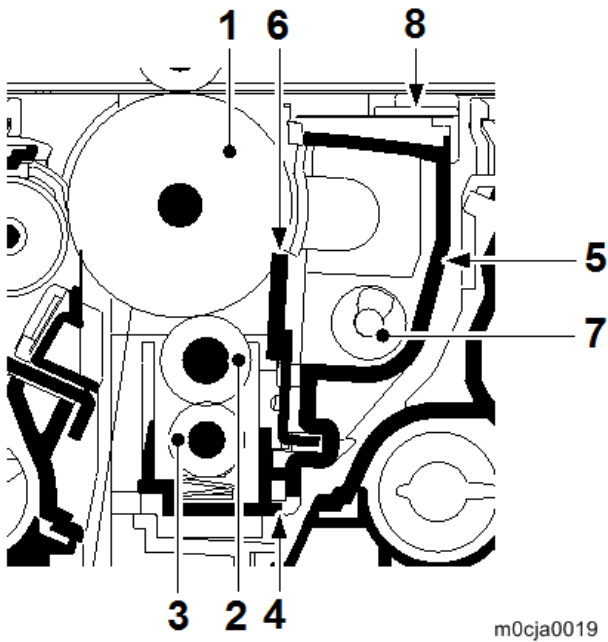

### Charger roller unit

The charged roller with the electric charge contacts the drum surface and rotates to charge the drum evenly.

No.	Name	No.	Name
1	Drum	3	Charger cleaning roller
2	Charge roller	4	Charge case

## 7.Detailed Descriptions

### Cleaning unit

The remaining toner on the drum surface after transferring is removed by the cleaning blade, and collected to the waste toner bottle by the drum screw. The cleaning lamp consists of the LED lamp, and it removes the remaining electric charge on the drum before the main charge.

No.	Name	No.	Name
5	Drum frame	7	Drum screw
6	Cleaning blade	8	Cleaning lamp

## Transfer Unit

### ITB Unit

The ITB unit consists of the transfer cleaning unit, the transfer belt and four ITB rollers facing each drum. When printing the color image, the toner image with a single color formed on each drum is repeatedly transferred on the transfer belt by impressing the bias to the ITB rollers facing each drum, and then the full color toner image is formed. Also, the ID sensor (PCB6/PCB7) attached to the main unit measures the toner density on the transfer belt.

The transfer cleaning unit collects the remaining toner on the transfer belt after the paper transfer, and forwards it to the waste toner bottle as waste toner.

No.	Name	No.A	Name
1	Tension roller	8	Cleaning fur brush
2	Drive roller	9	Cleaning roller
3	ITB roller K	10	Cleaning blade
4	ITB roller M	11	Cleaning screw
5	ITB roller C	12	ID sensor 1 (PCB6)
6	ITB roller Y	13	ID sensor 2 (PCB7)
7	Transfer belt		

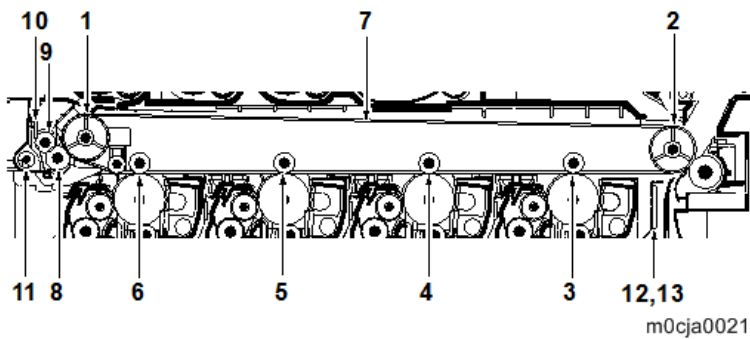

7.Detailed Descriptions

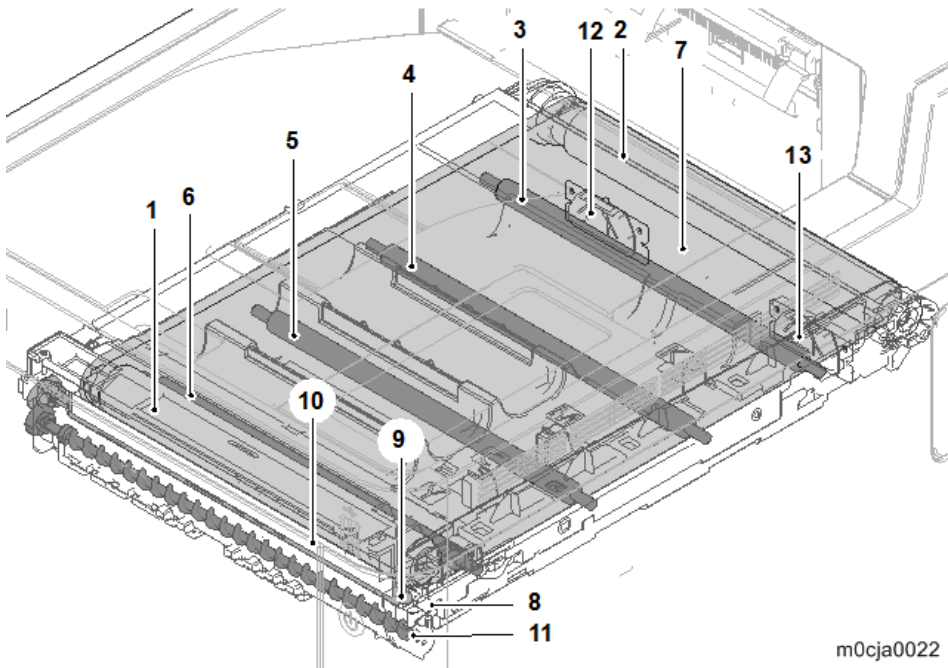

m0cja0022

PTR Unit

The PTR unit consists of the paper transfer roller attached to the paper conveying unit, and the separation brush. The DC bias from the HVP (PCB19) is impressed to the paper transfer roller, and the toner image formed on the transfer belt is transferred to the paper by the potential gap. After transferring, the paper is separated by self stripping and the electric charge on the paper is removed by the separation brush contacting the ground.

No.	Name	No.	Name
1	Paper transfer roller	3	Transfer front guide
2	ITB	4	Separation brush

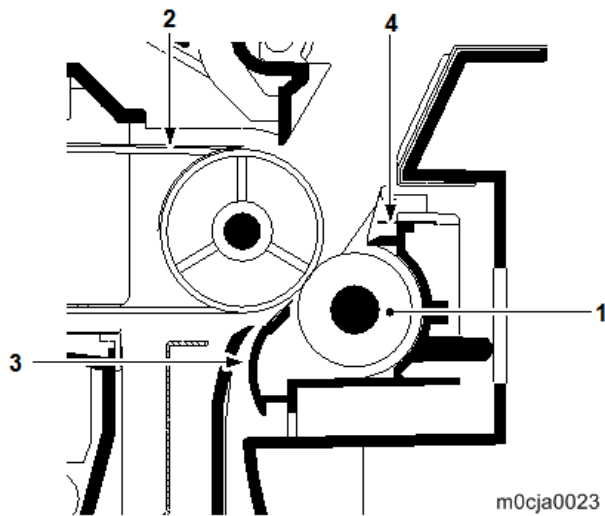

m0cja0023

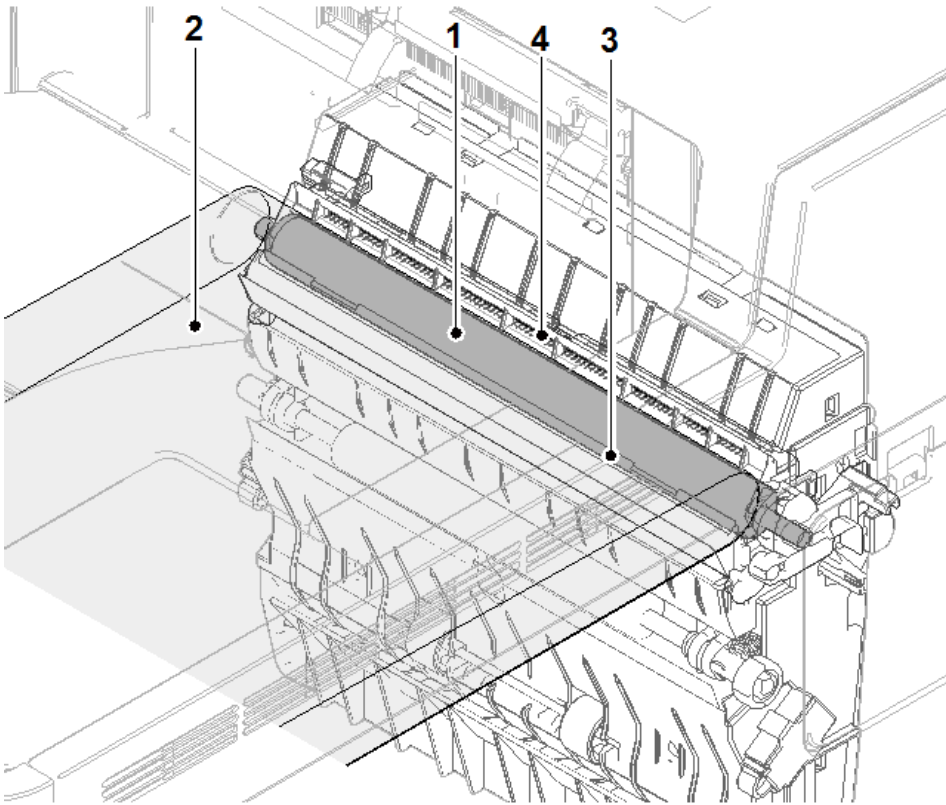

m0cja0024

## Fusing Unit

The paper from the transfer and separation section is pinched between the heat roller and the press roller. The heat roller is heated by the fusing heater, and the paper is pressed by the press roller with the pressure added by the pressure spring toward the heat roller, so toner is fused on the paper by that heat and pressure.

The surface temperature of the heat roller is detected by the fusing thermistor and controlled by the main/engine PCB (PCB1). If the fusing unit has abnormal temperature, the power supply line is shut off by switching the fusing thermostat and the fusing heater is turned off forcibly.

No.	Name	No.	Name
1	Heat roller	8	Separation plate
2	Fusing heater 1	9	Press roller
3	Fusing heater 2	10	Actuator (Exit sensor)
4	Fusing thermostat 1	11	Fusing exit roller
5	Fusing thermostat 2	12	Fusing exit pulley
6	Fusing thermistor 1	13	Fusing front guide
7	Fusing thermistor 2		

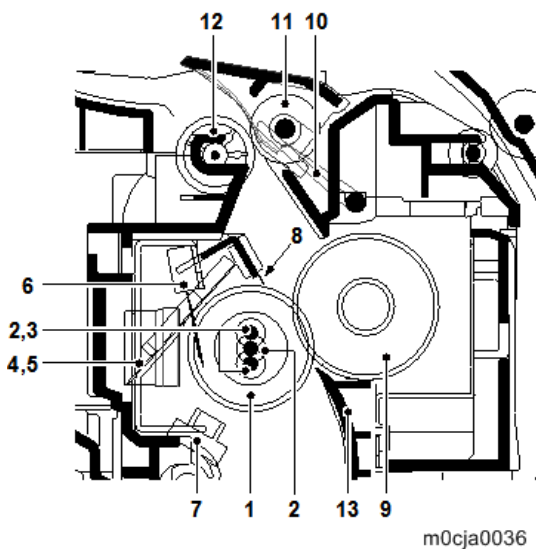

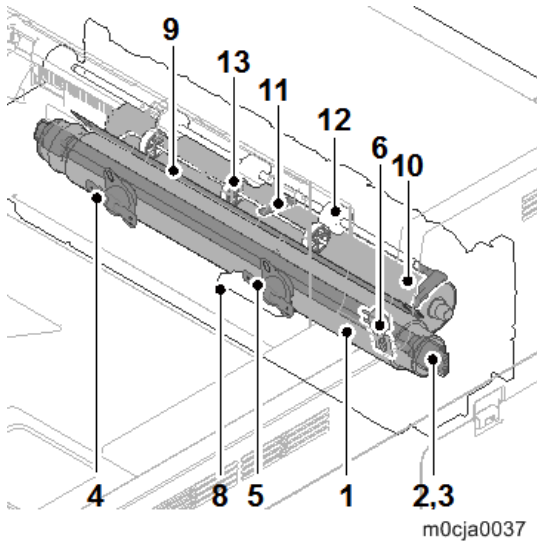

## Paper Exit Unit

The paper exit unit consists of the paper path from the fusing unit to the inner tray or the duplex unit.

No.	Name	No.	Name
1	Exit roller	6	Lower exit pulley
2	Exit pulley	7	Feedshift guide
3	Exit upper roller	8	Actuator (Exit sensor)
4	Exit upper pulley	9	Actuator (Exit full sensor)
5	Lower exit roller		

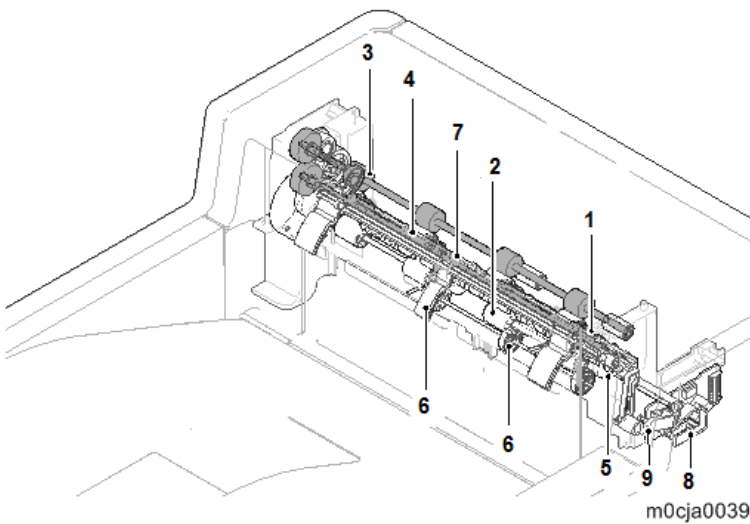
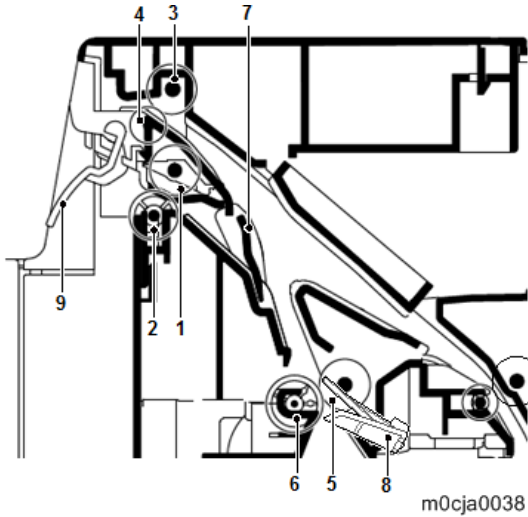

## Duplex Unit

The duplex unit consists of the transport path which sends the paper from the paper exit unit to the transportation section when duplex printing.

No.	Name	No.	Name
1	Duplex roller L	5	Duplex base
2	Duplex pulley L	6	Duplex guide
3	Duplex roller S	7	Actuator (duplex sensor)
4	Duplex pulley S		

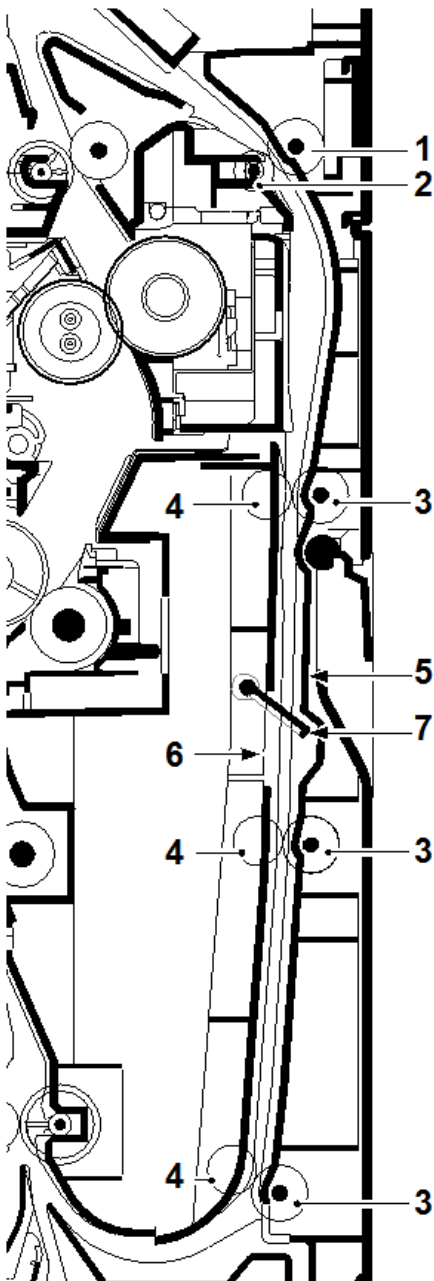

m0cja0040

## 7.Detailed Descriptions

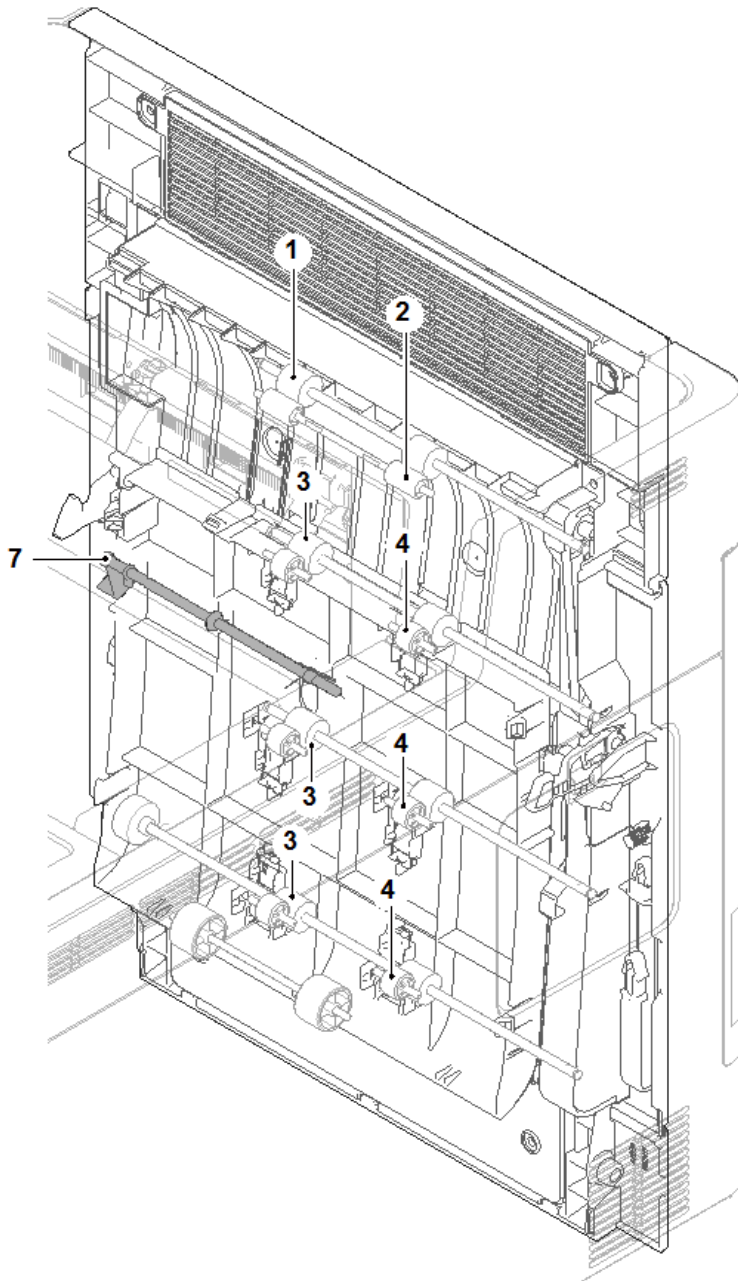

m0cja0041

## Paper Feed Unit

### Cassette paper feed section

The paper feed unit consists of the paper feed section that feeds paper from the cassette, the bypass tray, and the paper transport section that conveys the fed paper to the transportation section.

The cassette can contain 500 sheets. The sheet from the cassette is pulled out by rotation of the pickup roller and sent to the transportation section by rotation of the paper feed roller. The separation roller prevents multiple feeding.

No.	Name	No.	Name
1	Paper feed roller	7	Bottom plate
2	Pickup roller	8	Paper width guide
3	Feed roller holder	9	Paper length guide
4	Separation roller	10	Cassette base
5	Separation roller holder	11	Actuator (paper end sensor 1,2)
6	Friction pad		

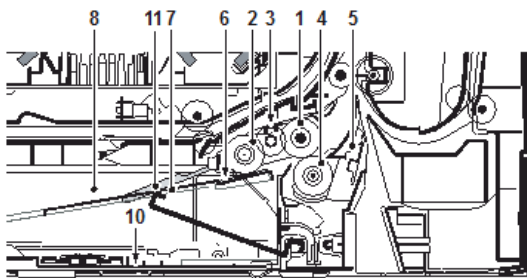

m0cja0042

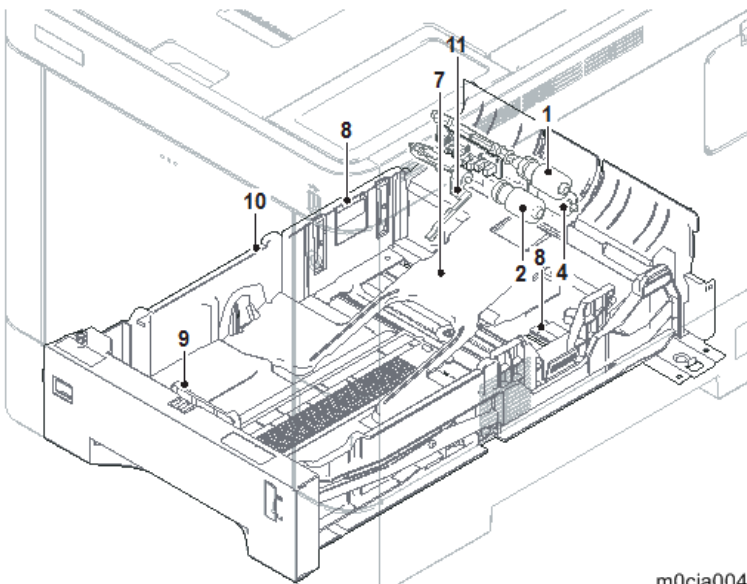

m0cja0043

### Conveying section

The paper conveying section conveys paper to the transfer unit when the paper is fed from the cassette or the bypass tray, or re-fed in the duplex print. The fed paper is conveyed to where it turns the

## 7.Detailed Descriptions

registration sensor (S1) on by the middle roller or the bypass conveying roller, and then, conveyed to the transfer unit by the registration front and rear rollers.

No.	Name	No.	Name
1	Bypass conveying roller	7	Front registration roller
2	Bypass conveying pulley	8	Rear registration roller
3	Upper bypass conveying guide	9	Bypass transport sensor (S6)
4	Lower bypass conveying guide	10	Actuator (Bypass transport sensor)
5	Middle roller	11	Registration sensor (S1)
6	Middle pulley		

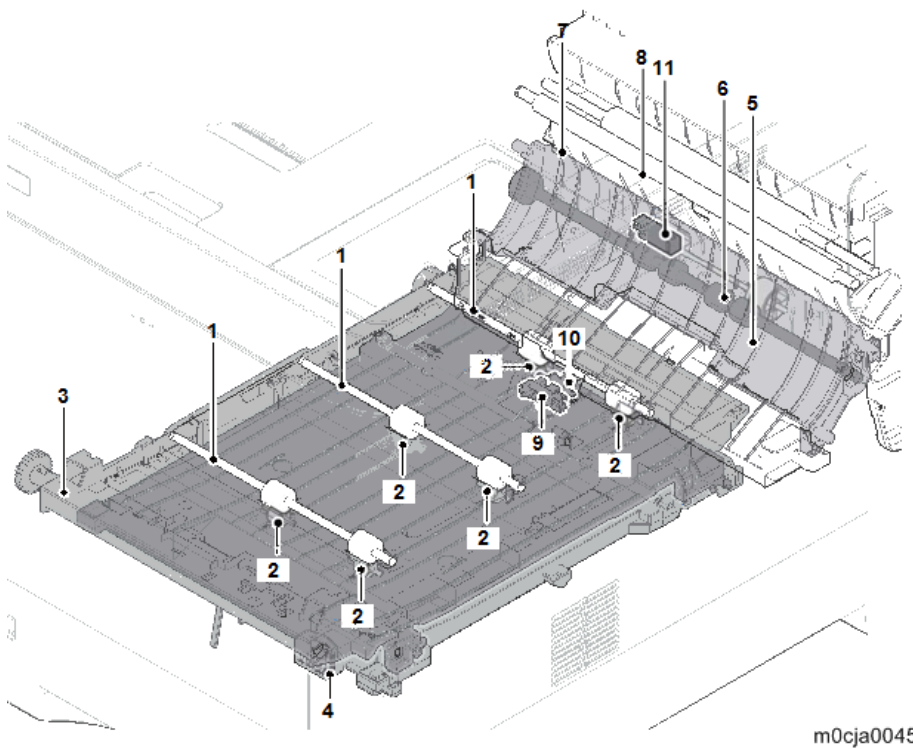
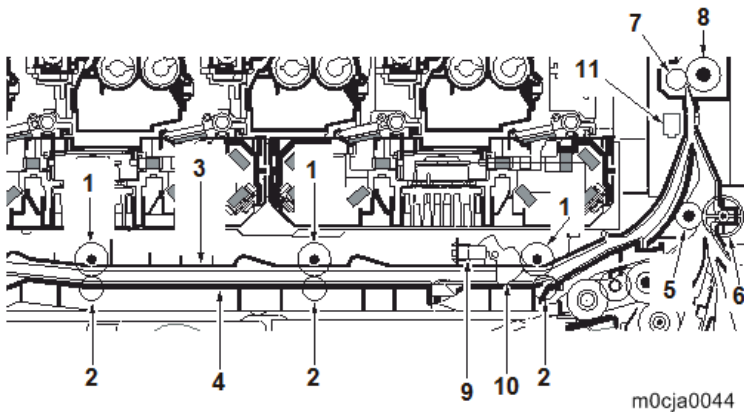

## Bypass Tray Unit

The bypass tray can contain 100 sheets. Feeding from the bypass tray is performed by the rotation of the bypass paper feed roller. The bypass separation pad prevents paper from multiple feeding.

No.	Name	No.	Name
1	Bypass paper feed roller	7	Bypass paper width guide
2	Bypass separation pad	8	Bypass base
3	Bypass bottom plate	9	Bypass cover
4	Bypass separation pad	10	Bypass tray
5	Bypass conveying roller	11	Actuator (bypass paper end sensor)
6	Bypass conveying pulley		

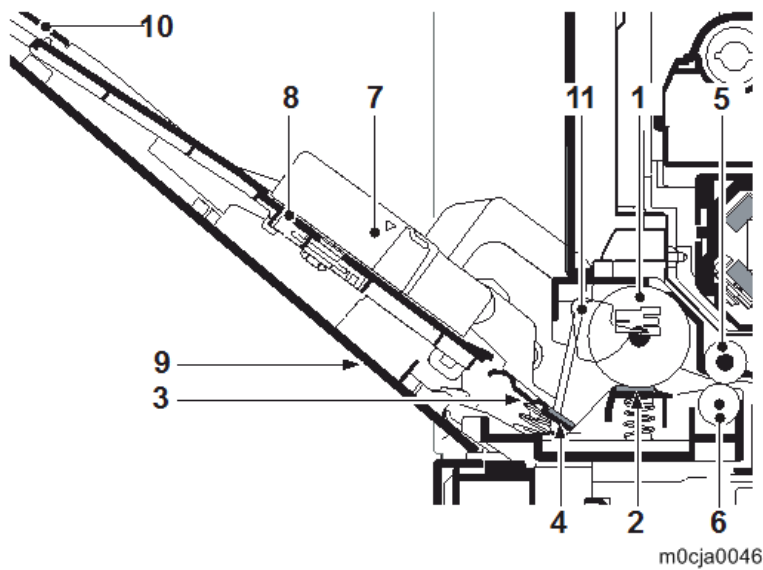

m0cja0046

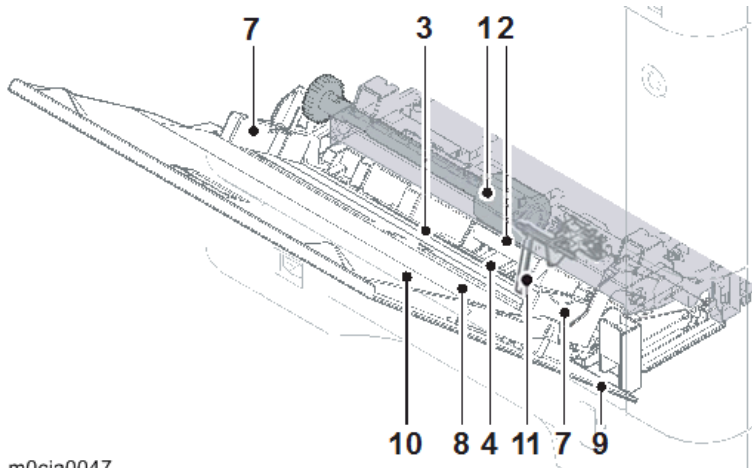

m0cja0047

**P C600**  
**Machine Code: M0CJ**  
**Appendices**  
**Ver 1.0**

**Latest Release: May, 2019**  
**Initial Release: May, 2019**  
**(c) 2019 Ricoh Co.,Ltd.**



# Table of Contents

1. Specifications.....	3
General Specifications.....	3
Mainframe.....	3
Supported Paper Sizes.....	5
Paper Feed.....	5
Software Accessories.....	7
Printer Drivers.....	7
Optional Equipment.....	9
Paper Feed Unit PB1150.....	9
2. Preventive Maintenance Tables.....	10
Maintenance Tables.....	10
Preventive Maintenance Items.....	10
3. SP Mode Tables.....	12
Service Program Mode.....	12
Enabling and Disabling Service Program Mode.....	12
Types of SP Modes.....	12
Service Table Key.....	13
Main SP Tables-1.....	14
SP1-XXX (Feed).....	14
Main SP Tables-2.....	17
SP2-XXX (Drum).....	17
Main SP Tables-3.....	40
SP3-XXX (Process).....	40
Main SP Tables-4.....	41
SP4-XXX.....	41
Main SP Tables-5 (Engine).....	54
SP5-XXX (Mode).....	54
Main SP Tables-5 (Controller).....	56
SP5-XXX (Mode).....	56
Main SP Tables-7 (Engine).....	90
SP7-XXX (Data Log).....	90
Main SP Tables-7 (Controller).....	99
SP7-XXX (Data Log).....	99
Main SP Tables-8.....	107
SP8-XXX (Data Log2).....	107
Printer Service Mode.....	143
Printer Service Mode.....	143

Input and Output Check.....156  
Input Check Table (SP5-803) .....156  
Output Check Table (SP5-804, SP5-805).....156

# 1. Specifications

## General Specifications

### Mainframe

Item		Specification
Configuration:		Desktop
Print process:		Laser beam scanning & Electrophotographic printing 4 drums tandem method
First print speed:		Full color: 7 seconds B&W: 6 seconds
Print speed:		One-side printing: 40 pages per minute (A4) Two-side printing: 36 pages per minute (A4)
Resolution:		600 x 600 dpi Speed (1 bit), 600 x 600 dpi Standard (2 bits), 600 x 600 dpi High Quality (4 bits), 1200 x 1200 dpi (1 bit)
Paper size:	Tray 1 (Standard Tray):	A4 SEF, A5 SEF, A5 LEF, A6 SEF, B5 JIS SEF, B6 JIS SEF, 16K SEF 8 <sup>1</sup> / <sub>2</sub> x 14 SEF, 8 <sup>1</sup> / <sub>2</sub> x 13 <sup>2</sup> / <sub>5</sub> SEF, 8 <sup>1</sup> / <sub>2</sub> x 13 SEF, 8 <sup>1</sup> / <sub>2</sub> x 11 SEF, 8 <sup>1</sup> / <sub>4</sub> x 14 SEF, 8 <sup>1</sup> / <sub>4</sub> x 13 SEF, 8 x 13 SEF, 8 x 10 SEF, 7 <sup>1</sup> / <sub>4</sub> x 10 <sup>1</sup> / <sub>2</sub> SEF, 5 <sup>1</sup> / <sub>2</sub> x 8 <sup>1</sup> / <sub>2</sub> SEF, 8 <sup>1</sup> / <sub>2</sub> x 13 <sup>2</sup> / <sub>5</sub> SEF <Custom Size Paper> Width: 105.0 mm (4.14 inch) - 216.0 mm (8.50 inch) Length: 148.0 mm (5.83 inch) - 356.0 mm (14.01 inch)
	Tray 2 to 4 (Optional Paper Feed Tray):	A4 SEF, A5 SEF, B5 JIS SEF, B6 JIS SEF, C5 Env SEF, C6 Env SEF, DL Env SEF, 16K SEF 8 <sup>1</sup> / <sub>2</sub> x 14 SEF, 8 <sup>1</sup> / <sub>2</sub> x 13 <sup>2</sup> / <sub>5</sub> SEF, 8 <sup>1</sup> / <sub>2</sub> x 13 SEF, 8 <sup>1</sup> / <sub>2</sub> x 11 SEF, 8 <sup>1</sup> / <sub>4</sub> x 14 SEF, 8 <sup>1</sup> / <sub>4</sub> x 13 SEF, 8 x 13 SEF, 8 x 10 SEF, 7 <sup>1</sup> / <sub>4</sub> x 10 <sup>1</sup> / <sub>2</sub> SEF, 5 <sup>1</sup> / <sub>2</sub> x 8 <sup>1</sup> / <sub>2</sub> SEF, 4 <sup>1</sup> / <sub>8</sub> x 9 <sup>1</sup> / <sub>2</sub> SEF, 3 <sup>7</sup> / <sub>8</sub> x 7 <sup>1</sup> / <sub>2</sub> SEF, 8 <sup>1</sup> / <sub>2</sub> x 13 <sup>2</sup> / <sub>5</sub> SEF <Custom Size Paper> Width: 105.0 mm (4.14 inch) - 216.0 mm (8.50 inch) Length: 162.0 mm (6.38 inch) - 356.0 mm (14.01 inch)
	Bypass Tray:	A4 SEF, A5 SEF, A5 LEF, A6 SEF, B5 JIS SEF, B6 JIS SEF, C5 Env SEF, C6 Env SEF, DL Env SEF, 16K SEF 8 <sup>1</sup> / <sub>2</sub> x 14 SEF, 8 <sup>1</sup> / <sub>2</sub> x 13 <sup>2</sup> / <sub>5</sub> SEF, 8 <sup>1</sup> / <sub>2</sub> x 13 SEF, 8 <sup>1</sup> / <sub>2</sub> x 11 SEF, 8 <sup>1</sup> / <sub>4</sub> x 14 SEF, 8 <sup>1</sup> / <sub>4</sub> x 13 SEF, 8 x 13 SEF, 8 x 10 SEF, 7 <sup>1</sup> / <sub>4</sub> x 10 <sup>1</sup> / <sub>2</sub> SEF, 5 <sup>1</sup> / <sub>2</sub> x 8 <sup>1</sup> / <sub>2</sub> SEF, 4 <sup>1</sup> / <sub>8</sub> x 9 <sup>1</sup> / <sub>2</sub> SEF, 3 <sup>7</sup> / <sub>8</sub> x 7 <sup>1</sup> / <sub>2</sub> SEF, 8 <sup>1</sup> / <sub>2</sub> x 13 <sup>2</sup> / <sub>5</sub> SEF <Custom Size Paper>

## 1. Specifications

Item		Specification
		Width: 70.0 mm (2.76 inch) - 216.0 mm (8.50 inch) Length: 148.0 mm (5.83 inch) - 356.0 mm (14.01 inch)
Paper weight:		60 - 220 g/m <sup>2</sup> (16 lb. Bond - 80 lb. Cover)
Paper output capacity:		Standard 500 sheets (80 g/m <sup>2</sup> , 20 lb. BOND)
Paper input capacity:	Standard paper feed tray	500 sheets (80 g/m <sup>2</sup> , 20 lb. BOND)
	Bypass tray	100 sheets (80 g/m <sup>2</sup> , 20 lb. BOND)
	500-sheet paper feed unit	500 sheets (80 g/m <sup>2</sup> , 20 lb. BOND)
Power requirements:		NA: 120–127 V, 60 Hz, 12 A EU/AP: 220–240 V, 50/60 Hz, 7 A
Maximum power consumption(main unit only):		NA: 1,500W EU/AP: 1,550W
Warm-up time:		24 seconds
Dimensions:		445 x 570 x 469.5 mm (17.5 x 22.4 x 18.5 inches)
Weight:		Approx. 34 kg (75.0 lb.)
Memory:		Standard 2 GB
Hard disk (Optional):		320 GB
Interfaces:		Standard: <ul style="list-style-type: none"> <li>• Gigabit Ethernet (10BASE-T/100BASE-TX/1000BASE-T)</li> <li>• USB 2.0</li> </ul> <p>To use USB 2.0, a USB computer port and cable that support USB 2.0 are required.</p> <ul style="list-style-type: none"> <li>• USB Host</li> <li>• SD card slot</li> </ul> Optional: <ul style="list-style-type: none"> <li>• IEEE 802.11a/b/g/n (Wireless LAN)</li> <li>• Parallel (Bidirectional IEEE 1284)</li> <li>• USB device server (10BASE-T/100BASE-TX/1000BASE-T)</li> </ul>
Printer Language:		PCL 5c, PCL 6, PostScript 3, PDF, XPS
Fonts:		PCL 6: 93 fonts PostScript 3, PDF: 136 fonts IPDS: 108 fonts
Network:		Topology: The physical or logical layout of the nodes (devices) in a network (10BASE-T/100BASE-TX/1000BASE-T) Protocol: TCP/IP (IPv4, IPv6)

## Supported Paper Sizes

### Paper Feed

#### Remarks:

A	Supported: Select the paper size using the control panel.
B	Supported: Select the paper size using the paper size dial on the tray.
C	Supported: Set the paper size dial on the tray to "Asterisk", and select the paper size with the control panel.
*	The duplex function cannot be used with envelopes.
-	Not supported.

Paper	Size	Bypass Tray	Tray 1 (Main Paper Feed Tray)	Tray 2 to 4 (Optional Paper Feed Tray)	Duplex
A4 SEF	210 × 297 mm	A	B	B	Yes
A5 SEF	148 × 210 mm	A	B	B	Yes
A5 LEF	210 × 148 mm	A	C	-	-
A6 SEF	105 × 148 mm	A	B	-	-
B5 JIS SEF	182 × 257 mm	A	C	C	Yes
B6 JIS SEF	128 × 182 mm	A	C	C	-
C5 Env. SEF	162 × 229 mm	A	-	C	-
C6 Env. SEF	114 × 162 mm	A	-	C	-
DL Env. SEF	110 × 220 mm	A	-	C	-
16K SEF	195 × 267 mm	A	C	C	Yes
Legal SEF	8.5 × 14 inch	A	B	B	Yes
8 <sup>1</sup> / <sub>2</sub> × 13 <sup>2</sup> / <sub>5</sub> SEF	8.5 × 13.4 inch	A	A	A	Yes

1.Specifications

Paper	Size	Bypass Tray	Tray 1 (Main Paper Feed Tray)	Tray 2 to 4 (Optional Paper Feed Tray)	Duplex
Foolscap SEF	8.5 × 13 inch	A	C	C	Yes
Letter SEF	8.5 × 11 inch	A	B	B	Yes
GovernmentLG SEF	8.25 × 14 inch	A	C	C	Yes
Folio SEF	8.25 × 13 inch	A	C	C	Yes
F/GL SEF	8 × 13 inch	A	C	C	Yes
Eng Quatro SEF	8 × 10 inch	A	C	C	Yes
Executive SEF	7.25 × 10.5 inch	A	C	C	Yes
Half Letter SEF	5.5 × 8.5 inch	A	B	B	Yes
Com10 Env. SEF	4.125 × 9.5 inch	A	-	C	-
Monarch Env. SEF	3.875 × 7.5 inch	A	-	C	-

**Custom:**

	Tray 1 (Main Tray)	Tray 2 to 4 (Optional Paper Feed Tray)	Bypass Tray
Width	105.0 - 216.0 mm 4.14 - 8.50 inch	105.0 - 216.0 mm 4.14 - 8.50 inch	70.0 - 216.0 mm 2.76 - 8.50 inch
Length	148.0 - 356.0 mm 5.83 - 14.01 inch	162.0 - 356.0 mm 6.38 - 14.01 inch	148.0 - 356.0 mm 5.83 - 14.01 inch

## Software Accessories

The printer drivers and utility software are provided on one CD-ROM. An auto-run installer allows you to select which components to install.

---

### Printer Drivers

---

#### Windows

OS	Type	PCL6	PS3
Windows 7	Starter	-	-
	Home Basic	-	-
	Home Premium	✓	✓
	Professional	✓	✓
	Ultimate	✓	✓
	Enterprise	✓	✓
Windows 8.1	Windows 8.1	✓	✓
	Pro	✓	✓
	Enterprise	✓	✓
	RT	-	-
Windows 10	Home	✓	✓
	Mobile	-	-
	Pro	✓	✓
	Enterprise	✓	✓
	Education	✓	✓
	Mobile Enterprise	-	-
	IoT Core	-	-
Windows Server 2008/R2	Standard Edition	✓	✓
	Enterprise Edition	✓	✓
	Standard without Hyper-V	✓	✓
	Enterprise without Hyper-V	✓	✓
	Datacenter Edition	-	-
	Web Edition	-	-
Windows Server 2012/R2	Foundation	✓	✓
	Essentials	✓	✓
	Standard	✓	✓
	Datacenter	-	-
Windows Server 2016	Standard	✓	✓
	Essentials	✓	✓
	Datacenter	✓	✓

## 1. Specifications

OS	Type	PCL6	PS3
	Multipoint Premium Server	✓	✓

✓: Supported

-: Not supported

\* RPCS driver has been discontinued.

### Mac OS Environment

OS	PS3	Printer Utility for Mac
Mac OS 8.6 or later, Mac OS X classic	-	-
OS X 10.10-10.11, macOS 10.12-10.13	✓	-

✓: Supported

-: Not supported

## Optional Equipment

### Paper Feed Unit PB1150

Item	Specification
Paper Size:	A4 SEF, A5 SEF, B5 JIS SEF, B6 JIS SEF, C5 Env SEF, C6 Env SEF, DL Env SEF, 16K SEF 8/x 14 SEF, 8/x 13/SEF, 8/x 13 SEF, 8/x 11 SEF, 8/x 14 SEF, 8/x 13 SEF, 8 x 13 SEF, 8 x 10 SEF, 7/x 10/SEF, 5/x 8/SEF, 4/x 9/SEF, 3/x 7/SEF, 8/x 13/SEF <Custom Size Paper> Width: 105.0 mm (4.14 inch) - 216.0 mm (8.50 inch) Length: 162.0 mm (6.38 inch) - 356.0 mm (14.01 inch)
Paper Weight:	60 - 220 g/m <sup>2</sup> (16 lb. Bond - 80 lb. Cover)
Paper Capacity:	500 sheets (80 g/m <sup>2</sup> , 20 lb. Bond)
Power Consumption:	25 W or less (Power is supplied from the main unit.)
Dimension (W × D × H):	390 × 532 × 116 mm (15.4 × 20.9 × 4.6 inches)
Weight:	4.1 kg (9.0 lb.)

## 2. Preventive Maintenance Tables

### Maintenance Tables

**Note**

- The amounts mentioned as the PM interval indicate the number of prints.

#### Preventive Maintenance Items

Chart: A4 (LT)/6%

Mode: 3 prints/job

Environment: Normal temperature and humidity

Yield may change depending on circumstances and print conditions.

Symbol keys: C: Clean, R: Replace, L: Lubricant, I: Inspect

**Note**

- Yield Parts: The parts mentioned in these tables have a target yield. However, the total copy/print volume made by the machine will not reach the target yield within the machine's targeted lifetime if the machine is used under the target usage conditions (ACV, color ratio, and P/J). So, these parts are categorized not as PM parts but as yield parts (EM parts). The parts with "(R)" in this table are yield parts.

#### Mainframe

##### Mainframe

Item	300K	EM	Life	Note
Drum unit	(R)	-	-	
Development Unit	(R)	-	-	
Fusing Unit	(R)	-	-	
ITB unit	(R)	-	-	
Paper feed roller	(R)	-	-	
Separation roller	(R)	-	-	
Paper transfer roller unit	(R)	-	-	
Bypass paper feed roller	(R)	-	-	
Registration roller	-	C	-	Wipe with a soft dry cloth.

#### Paper Feed Unit PB1150

Item	300K	EM	Life	Note
Paper feed roller	(R)	C	-	Wipe with a soft cloth infiltrated with alcohol or water.

## 2.Preventive Maintenance Tables

Item	300K	EM	Life	Note
Retard roller	(R)	C	-	Wipe with a soft cloth infiltrated with alcohol or water.

## 3.SP Mode Tables

---

### Service Program Mode

#### CAUTION

- Make sure that the data-in LED (↻) is not on before you go into the SP mode. This LED indicates that some data is coming to the machine. When the LED is on, wait for the machine to process the data.

---

### Enabling and Disabling Service Program Mode

---

#### Note

- The Service Program Mode is for use by service representatives only. If this mode is used by anyone other than service representatives for any reason, data might be deleted or settings might be changed. In such case, product quality cannot be guaranteed any more.

#### Entering SP Mode

---

For details, ask your supervisor.

#### Exiting SP Mode

---

Select [End] from the service mode main menu, and then press [OK].

---

### Types of SP Modes

---

Select one of the Service Program modes from the diagram below after you access the SP mode.

- Service SP: SP modes related to the controller/printer functions
- Engine SP: SP modes related to the engine functions

#### SP Mode Button Summary

---

Select one of the Service Program modes (Service, or Engine) with [▲/▼] keys, and then press the [OK] key.



---

### Service Mode Lock/Unlock

---

At locations where the machine contains sensitive data, the service representative cannot operate the machine until the Administrator turns the service mode lock off. This function makes sure that work on the machine is always done with the permission of the Administrator.

1. If you cannot go into the SP mode, ask the Administrator to log in as the machine administrator, and then set "Service Mode Lock" to OFF:

Security Options -> Service Mode Lock -> Off

- This unlocks the machine and lets you get access to all the SP codes.
- The service representative can service the machine and turn the machine off and on. It is not necessary to ask the Administrator to log in again each time the machine is turned on.

**2.** Go into the SP mode and set SP5-169-001 to "1" if you must use the printer bit switches.

**3.** After machine servicing is completed:

- Change SP5-169-001 from "1" to "0".
- Turn the main power off and on. Tell the administrator that you have completed servicing the machine.
- The Administrator will then set the "Service Mode Lock" to ON.

---

### Service Table Key

---

Notation	What it means
ENG	Engine SP
CTL	Controller SP
[Min to Max/Init./Step]	Example: [-9 to 9 / 0 / 0.1mm]. The setting can be adjusted in the range $\pm 9$ , value reset to 0 after an NVRAM reset, and the value can be changed in 0.1 mm steps with each key press.
*	Value stored in NVRAM. After a RAM reset, this default value (factory setting) is restored.

## Main SP Tables-1

### SP1-XXX (Feed)

SP No.	Large Category	Small Category	ENG or CTL	[Min to Max/Init./Step]
1-001-001	Leading Edge Reg.	By-pass Tray	ENG*	[-0.5 to 0.5/0/0.1mm]
1-001-002	Leading Edge Reg.	Paper Tray 1	ENG*	[-0.5 to 0.5/0/0.1mm]
1-001-003	Leading Edge Reg.	Paper Tray 2	ENG*	[-0.5 to 0.5/0/0.1mm]
1-001-004	Leading Edge Reg.	Paper Tray 3	ENG*	[-0.5 to 0.5/0/0.1mm]
1-001-005	Leading Edge Reg.	Paper Tray 4	ENG*	[-0.5 to 0.5/0/0.1mm]
1-001-011	Leading Edge Reg.	Duplex	ENG*	[-0.5 to 0.5/0/0.1mm]
1-001-101	Leading Edge Reg.	By-pass Tray:user	ENG*	[-0.5 to 0.5/0/0.1mm]
1-001-102	Leading Edge Reg.	Paper Tray 1:user	ENG*	[-0.5 to 0.5/0/0.1mm]
1-001-103	Leading Edge Reg.	Paper Tray 2:user	ENG*	[-0.5 to 0.5/0/0.1mm]
1-001-104	Leading Edge Reg.	Paper Tray 3:user	ENG*	[-0.5 to 0.5/0/0.1mm]
1-001-105	Leading Edge Reg.	Paper Tray 4:user	ENG*	[-0.5 to 0.5/0/0.1mm]
1-001-111	Leading Edge Reg.	Duplex:user	ENG*	[-0.5 to 0.5/0/0.1mm]
1-002-001	Leading Edge Reg.	By-pass Tray	ENG*	[-0.4 to 0.4/0/0.1mm]
1-002-002	Leading Edge Reg.	Paper Tray 1	ENG*	[-0.4 to 0.4/0/0.1mm]
1-002-003	Leading Edge Reg.	Paper Tray 2	ENG*	[-0.4 to 0.4/0/0.1mm]
1-002-004	Leading Edge Reg.	Paper Tray 3	ENG*	[-0.4 to 0.4/0/0.1mm]
1-002-005	Leading Edge Reg.	Paper Tray 4	ENG*	[-0.4 to 0.4/0/0.1mm]
1-002-011	Leading Edge Reg.	Duplex	ENG*	[-0.4 to 0.4/0/0.1mm]
1-002-101	Leading Edge Reg.	By-pass Tray:user	ENG*	[-0.4 to 0.4/0/0.1mm]
1-002-102	Leading Edge Reg.	Paper Tray 1:user	ENG*	[-0.4 to 0.4/0/0.1mm]
1-002-103	Leading Edge Reg.	Paper Tray 2:user	ENG*	[-0.4 to 0.4/0/0.1mm]
1-002-104	Leading Edge Reg.	Paper Tray 3:user	ENG*	[-0.4 to 0.4/0/0.1mm]
1-002-105	Leading Edge Reg.	Paper Tray 4:user	ENG*	[-0.4 to 0.4/0/0.1mm]
1-002-111	Leading Edge Reg.	Duplex:user	ENG*	[-0.4 to 0.4/0/0.1mm]
1-003-001	Paper Buckle	By-pass:Light	ENG*	[-1.2 to 1.2/0/0.1mm]
1-003-002	Paper Buckle	Tray1:Light	ENG*	[-1.2 to 1.2/0/0.1mm]
1-003-003	Paper Buckle	Tray2:Light	ENG*	[-1.2 to 1.2/0/0.1mm]
1-003-004	Paper Buckle	Tray3:Light	ENG*	[-1.2 to 1.2/0/0.1mm]
1-003-005	Paper Buckle	Tray4:Light	ENG*	[-1.2 to 1.2/0/0.1mm]
1-003-006	Paper Buckle	Duplex:Light	ENG*	[-1.2 to 1.2/0/0.1mm]
1-003-007	Paper Buckle	By-pass:Normal	ENG*	[-1.2 to 1.2/0/0.1mm]
1-003-008	Paper Buckle	Tray1:Normal	ENG*	[-1.2 to 1.2/0/0.1mm]
1-003-009	Paper Buckle	Tray2:Normal	ENG*	[-1.2 to 1.2/0/0.1mm]
1-003-010	Paper Buckle	Tray3:Normal	ENG*	[-1.2 to 1.2/0/0.1mm]

## 3.SP Mode Tables

SP No.	Large Category	Small Category	ENG or CTL	[Min to Max/Init./Step]
1-003-011	Paper Buckle	Tray4:Normal	ENG*	[-1.2 to 1.2/0/0.1mm]
1-003-012	Paper Buckle	Duplex:Normal	ENG*	[-1.2 to 1.2/0/0.1mm]
1-003-013	Paper Buckle	By-pass:Heavy	ENG*	[-1.2 to 1.2/0/0.1mm]
1-003-014	Paper Buckle	Tray1:Heavy	ENG*	[-1.2 to 1.2/0/0.1mm]
1-003-015	Paper Buckle	Tray2:Heavy	ENG*	[-1.2 to 1.2/0/0.1mm]
1-003-016	Paper Buckle	Tray3:Heavy	ENG*	[-1.2 to 1.2/0/0.1mm]
1-003-017	Paper Buckle	Tray4:Heavy	ENG*	[-1.2 to 1.2/0/0.1mm]
1-003-018	Paper Buckle	Duplex:Heavy	ENG*	[-1.2 to 1.2/0/0.1mm]
1-998-001	Reserve SP	reserve01	ENG*	[0 to 255/0/1]
1-998-002	Reserve SP	reserve02	ENG*	[0 to 255/0/1]
1-998-003	Reserve SP	reserve03	ENG*	[0 to 255/0/1]
1-998-004	Reserve SP	reserve04	ENG*	[0 to 255/0/1]
1-998-005	Reserve SP	reserve05	ENG*	[0 to 255/0/1]
1-998-006	Reserve SP	reserve06	ENG*	[0 to 255/0/1]
1-998-007	Reserve SP	reserve07	ENG*	[0 to 255/0/1]
1-998-008	Reserve SP	reserve08	ENG*	[0 to 255/0/1]
1-998-009	Reserve SP	reserve09	ENG*	[0 to 255/0/1]
1-998-010	Reserve SP	reserve10	ENG*	[0 to 255/0/1]
1-998-011	Reserve SP	reserve11	ENG*	[0 to 255/0/1]
1-998-012	Reserve SP	reserve12	ENG*	[0 to 255/0/1]
1-998-013	Reserve SP	reserve13	ENG*	[0 to 255/0/1]
1-998-014	Reserve SP	reserve14	ENG*	[0 to 255/0/1]
1-998-015	Reserve SP	reserve15	ENG*	[0 to 255/0/1]
1-998-016	Reserve SP	reserve16	ENG*	[0 to 255/0/1]
1-998-017	Reserve SP	reserve17	ENG*	[0 to 65535/0/1]
1-998-018	Reserve SP	reserve18	ENG*	[0 to 65535/0/1]
1-998-019	Reserve SP	reserve19	ENG*	[0 to 65535/0/1]
1-998-020	Reserve SP	reserve20	ENG*	[0 to 65535/0/1]
1-998-021	Reserve SP	reserve21	ENG*	[0 to 65535/0/1]
1-998-022	Reserve SP	reserve22	ENG*	[0 to 65535/0/1]
1-998-023	Reserve SP	reserve23	ENG*	[0 to 65535/0/1]
1-998-024	Reserve SP	reserve24	ENG*	[0 to 65535/0/1]
1-998-025	Reserve SP	reserve25	ENG*	[0 to 4294967295/0/1]
1-998-026	Reserve SP	reserve26	ENG*	[0 to 4294967295/0/1]
1-998-027	Reserve SP	reserve27	ENG*	[0 to 4294967295/0/1]
1-998-028	Reserve SP	reserve28	ENG*	[0 to 4294967295/0/1]
1-998-029	Reserve SP	reserve29	ENG*	[0 to 4294967295/0/1]

### 3.SP Mode Tables

SP No.	Large Category	Small Category	ENG or CTL	[Min to Max/Init./Step]
1-998-030	Reserve SP	reserve30	ENG*	[0 to 4294967295/0/1]
1-998-031	Reserve SP	reserve31	ENG*	[0 to 4294967295/0/1]
1-998-032	Reserve SP	reserve32	ENG*	[0 to 4294967295/0/1]
1-998-033	Reserve SP	reserve33	ENG*	[0 to 255/0/1]
1-998-034	Reserve SP	reserve34	ENG*	[0 to 255/0/1]

## Main SP Tables-2

### SP2-XXX (Drum)

SP No.	Large Category	Small Category	ENG or CTL	[Min to Max/Init./Step]
2-101-005	Color Regist Adj.	Ma: M. Cor.: Dot	ENG*	[-1.42 to 1.42/0/0.01dot]
2-101-006	Color Regist Adj.	Cy: M. Cor.: Dot	ENG*	[-1.42 to 1.42/0/0.01dot]
2-101-007	Color Regist Adj.	Ye: M. Cor.: Dot	ENG*	[-1.42 to 1.42/0/0.01dot]
2-101-012	Color Regist Adj.	Bk: S. Cor.: Line	ENG*	[-236 to 236/0/1line]
2-101-013	Color Regist Adj.	Ma: S. Cor.: Line	ENG*	[-236 to 236/0/1line]
2-101-014	Color Regist Adj.	Cy: S. Cor.: Line	ENG*	[-236 to 236/0/1line]
2-101-015	Color Regist Adj.	Ye: S. Cor.: Line	ENG*	[-236 to 236/0/1line]
2-101-021	Color Regist Adj.	Ma:AreaMag.Cor.23	ENG*	[-0.00001 to 0.00001/0/0.00001]
2-101-022	Color Regist Adj.	Ma:AreaMag.Cor.45	ENG*	[-0.00001 to 0.00001/0/0.00001]
2-101-023	Color Regist Adj.	Ma:AreaMag.Cor.67	ENG*	[-0.00001 to 0.00001/0/0.00001]
2-101-024	Color Regist Adj.	Ma:AreaMag.Cor.89	ENG*	[-0.00001 to 0.00001/0/0.00001]
2-101-025	Color Regist Adj.	Ma:Area Mag. All	ENG*	[-0.00001 to 0.00001/0/0.00001]
2-101-031	Color Regist Adj.	Cy:AreaMag.Cor.23	ENG*	[-0.00001 to 0.00001/0/0.00001]
2-101-032	Color Regist Adj.	Cy:AreaMag.Cor.45	ENG*	[-0.00001 to 0.00001/0/0.00001]
2-101-033	Color Regist Adj.	Cy:AreaMag.Cor.67	ENG*	[-0.00001 to 0.00001/0/0.00001]
2-101-034	Color Regist Adj.	Cy:AreaMag.Cor.89	ENG*	[-0.00001 to 0.00001/0/0.00001]
2-101-	Color Regist Adj.	Cy:Area Mag. All	ENG*	[-0.00001 to

### 3.SP Mode Tables

SP No.	Large Category	Small Category	ENG or CTL	[Min to Max/Init./Step]
035				0.00001/0/0.00001]
2-101-041	Color Regist Adj.	Ye:AreaMag.Cor.23	ENG*	[-0.00001 to 0.00001/0/0.00001]
2-101-042	Color Regist Adj.	Ye:AreaMag.Cor.45	ENG*	[-0.00001 to 0.00001/0/0.00001]
2-101-043	Color Regist Adj.	Ye:AreaMag.Cor.67	ENG*	[-0.00001 to 0.00001/0/0.00001]
2-101-044	Color Regist Adj.	Ye:AreaMag.Cor.89	ENG*	[-0.00001 to 0.00001/0/0.00001]
2-101-045	Color Regist Adj.	Ye:Area Mag. All	ENG*	[-0.00001 to 0.00001/0/0.00001]
2-102-001	Mag. Adj.	Bk: Main Mag	ENG*	[-0.001 to 0.001/0/0.001%]
2-102-021	Mag. Adj.	Bk:MainBeamPitch	ENG*	[0 to 0.4/5.67/0.01dot]
2-102-022	Mag. Adj.	Ma:MainBeamPitch	ENG*	[0 to 0.4/5.46/0.01dot]
2-102-023	Mag. Adj.	Cy:MainBeamPitch	ENG*	[0 to 0.4/5.67/0.01dot]
2-102-024	Mag. Adj.	Ye:MainBeamPitch	ENG*	[0 to 0.4/5.46/0.01dot]
2-103-001	Erase Margin Adj.	Lead Edge Width	ENG*	[0 to 0.8/4.2/0.1mm]
2-103-002	Erase Margin Adj.	Trail. Edge Width	ENG*	[0 to 0.8/4.2/0.1mm]
2-103-003	Erase Margin Adj.	Left Edge Width	ENG*	[0 to 0.8/4.2/0.1mm]
2-103-004	Erase Margin Adj.	Right Edge Width	ENG*	[0 to 0.8/4.2/0.1mm]
2-103-005	Erase Margin Adj.	Dup. Trail. Edge	ENG*	[-0.6 to 0.6/0/0.1mm]
2-103-006	Erase Margin Adj.	Dup. Left Edge	ENG*	[-0.6 to 0.6/0/0.1mm]
2-103-007	Erase Margin Adj.	Dup. Right Edge	ENG*	[-0.6 to 0.6/0/0.1mm]
2-103-	Erase Margin	Thick Lead Edge	ENG*	[-0.6 to 0.6/0/0.1mm]

## 3.SP Mode Tables

SP No.	Large Category	Small Category	ENG or CTL	[Min to Max/Init./Step]
011	Adj.			
2-103-012	Erase Margin Adj.	Thick:Trail Edge	ENG*	[-0.6 to 0.6/0/0.1mm]
2-103-013	Erase Margin Adj.	Thick:Dup. Trail	ENG*	[-0.6 to 0.6/0/0.1mm]
2-103-014	Erase Margin Adj.	Thick: Dup. Left	ENG*	[-0.6 to 0.6/0/0.1mm]
2-103-015	Erase Margin Adj.	Thick: Dup. Right	ENG*	[-0.6 to 0.6/0/0.1mm]
2-103-021	Erase Margin Adj.	Thin:Lead Edge	ENG*	[-0.6 to 0.6/0/0.1mm]
2-103-022	Erase Margin Adj.	Thin:Trail.Edge	ENG*	[-0.6 to 0.6/0/0.1mm]
2-103-023	Erase Margin Adj.	Thin:Duplex Trail	ENG*	[-0.6 to 0.6/0/0.1mm]
2-103-024	Erase Margin Adj.	Thin Duplex Left	ENG*	[-0.6 to 0.6/0/0.1mm]
2-103-025	Erase Margin Adj.	Thin:Duplex Right	ENG*	[-0.6 to 0.6/0/0.1mm]
2-104-001	Manual Pos. Adj.	Ma M. Cor.L Input	ENG	[0 to 18/9/1]
2-104-002	Manual Pos. Adj.	Ma M. Cor.R Input	ENG	[0 to 18/9/1]
2-104-003	Manual Pos. Adj.	Cy M. Cor.L Input	ENG	[0 to 18/9/1]
2-104-004	Manual Pos. Adj.	Cy M. Cor.R Input	ENG	[0 to 18/9/1]
2-104-005	Manual Pos. Adj.	Ye M. Cor.L Input	ENG	[0 to 18/9/1]
2-104-006	Manual Pos. Adj.	Ye M. Cor.R Input	ENG	[0 to 18/9/1]
2-104-010	Manual Pos. Adj.	Ma S. Cor. Input	ENG	[0 to 18/9/1]
2-104-011	Manual Pos. Adj.	Cy S. Cor. Input	ENG	[0 to 18/9/1]
2-104-	Manual Pos. Adj.	Ye S. Cor. Input	ENG	[0 to 18/9/1]

### 3.SP Mode Tables

SP No.	Large Category	Small Category	ENG or CTL	[Min to Max/Init./Step]
012				
2-104-020	Manual Pos. Adj.	Ma M. Cor.1 Input	ENG	[0 to 18/9/1]
2-104-021	Manual Pos. Adj.	Ma M. Cor.2 Input	ENG	[0 to 18/9/1]
2-104-022	Manual Pos. Adj.	Ma M. Cor.3 Input	ENG	[0 to 18/9/1]
2-104-023	Manual Pos. Adj.	Ma M. Cor.4 Input	ENG	[0 to 18/9/1]
2-104-024	Manual Pos. Adj.	Ma M. Cor.5 Input	ENG	[0 to 18/9/1]
2-104-025	Manual Pos. Adj.	Cy M. Cor.1 Input	ENG	[0 to 18/9/1]
2-104-026	Manual Pos. Adj.	Cy M. Cor.2 Input	ENG	[0 to 18/9/1]
2-104-027	Manual Pos. Adj.	Cy M. Cor.3 Input	ENG	[0 to 18/9/1]
2-104-028	Manual Pos. Adj.	Cy M. Cor.4 Input	ENG	[0 to 18/9/1]
2-104-029	Manual Pos. Adj.	Cy M. Cor.5 Input	ENG	[0 to 18/9/1]
2-104-030	Manual Pos. Adj.	Ye M. Cor.1 Input	ENG	[0 to 18/9/1]
2-104-031	Manual Pos. Adj.	Ye M. Cor.2 Input	ENG	[0 to 18/9/1]
2-104-032	Manual Pos. Adj.	Ye M. Cor.3 Input	ENG	[0 to 18/9/1]
2-104-033	Manual Pos. Adj.	Ye M. Cor.4 Input	ENG	[0 to 18/9/1]
2-104-034	Manual Pos. Adj.	Ye M. Cor.5 Input	ENG	[0 to 18/9/1]
2-104-040	Manual Pos. Adj.	Ma S. Cor.3 Input	ENG	[0 to 18/9/1]
2-104-041	Manual Pos. Adj.	Cy S. Cor.3 Input	ENG	[0 to 18/9/1]
2-104-	Manual Pos. Adj.	Ye S. Cor.3 Input	ENG	[0 to 18/9/1]

## 3.SP Mode Tables

SP No.	Large Category	Small Category	ENG or CTL	[Min to Max/Init./Step]
042				
2-104-050	Manual Pos. Adj.	Ma M. Cor.1 Init	ENG	[-14200 to 14200/0/1]
2-104-051	Manual Pos. Adj.	Ma M. Cor.2 Init	ENG	[-14200 to 14200/0/1]
2-104-052	Manual Pos. Adj.	Ma M. Cor.3 Init	ENG	[-14200 to 14200/0/1]
2-104-053	Manual Pos. Adj.	Ma M. Cor.4 Init	ENG	[-14200 to 14200/0/1]
2-104-054	Manual Pos. Adj.	Ma M. Cor.5 Init	ENG	[-14200 to 14200/0/1]
2-104-055	Manual Pos. Adj.	Cy M. Cor.1 Init	ENG	[-14200 to 14200/0/1]
2-104-056	Manual Pos. Adj.	Cy M. Cor.2 Init	ENG	[-14200 to 14200/0/1]
2-104-057	Manual Pos. Adj.	Cy M. Cor.3 Init	ENG	[-14200 to 14200/0/1]
2-104-058	Manual Pos. Adj.	Cy M. Cor.4 Init	ENG	[-14200 to 14200/0/1]
2-104-059	Manual Pos. Adj.	Cy M. Cor.5 Init	ENG	[-14200 to 14200/0/1]
2-104-060	Manual Pos. Adj.	Ye M. Cor.1 Init	ENG	[-14200 to 14200/0/1]
2-104-061	Manual Pos. Adj.	Ye M. Cor.2 Init	ENG	[-14200 to 14200/0/1]
2-104-062	Manual Pos. Adj.	Ye M. Cor.3 Init	ENG	[-14200 to 14200/0/1]
2-104-063	Manual Pos. Adj.	Ye M. Cor.4 Init	ENG	[-14200 to 14200/0/1]
2-104-064	Manual Pos. Adj.	Ye M. Cor.5 Init	ENG	[-14200 to 14200/0/1]
2-104-070	Manual Pos. Adj.	Ma S. Cor.1 Init	ENG	[-23600 to 23600/0/1]
2-104-071	Manual Pos. Adj.	Ma S. Cor.3 Init	ENG	[-23600 to 23600/0/1]
2-104-	Manual Pos. Adj.	Ma S. Cor.5 Init	ENG	[-23600 to 23600/0/1]

### 3.SP Mode Tables

SP No.	Large Category	Small Category	ENG or CTL	[Min to Max/Init./Step]
072				
2-104-080	Manual Pos. Adj.	Normal Exec	ENG	[0 to 1/0/1]
2-104-081	Manual Pos. Adj.	Detail Exec	ENG	[0 to 1/0/1]
2-104-082	Manual Pos. Adj.	Init. Exec	ENG	[0 to 1/0/1]
2-109-003	Test Pattern	Pattern Selection	ENG	[0 to 24/0/1]
2-109-005	Test Pattern	Color Selection	ENG	[1 to 5/1/1]
2-109-006	Test Pattern	Bk: Density	ENG	[0 to 15/15/1]
2-109-007	Test Pattern	Ma: Density	ENG	[0 to 15/15/1]
2-109-008	Test Pattern	Cy: Density	ENG	[0 to 15/15/1]
2-109-009	Test Pattern	Ye: Density	ENG	[0 to 15/15/1]
2-109-010	Test Pattern	Print Side Select	ENG	[0 to 1/0/1]
2-109-011	Test Pattern	1 Sheet Printing	ENG	[0 to 1/0/1]
2-109-012	Test Pattern	Continue Printing	ENG	[0 to 1/0/1]
2-111-001	Calibration	Calib. Exec.	ENG	[0 to 1/0/1]
2-120-001	Trigger Shift	offset	ENG*	[0 to 16000/0/1dot]
2-140-001	Error Status	Pos.Adj.Latest	ENG*	[0 to 25/0/1]
2-140-002	Error Status	Pos.Adj.2T-Befo.	ENG*	[0 to 25/0/1]
2-140-003	Error Status	Pos.Adj.3T-Befo.	ENG*	[0 to 25/0/1]
2-140-004	Error Status	Pos.Adj.4T-Befo.	ENG*	[0 to 25/0/1]

## 3.SP Mode Tables

SP No.	Large Category	Small Category	ENG or CTL	[Min to Max/Init./Step]
2-140-011	Error Status	Thic.Cal..Latest	ENG*	[0 to 25/0/1]
2-140-012	Error Status	Thic.Cal.2T-Befo.	ENG*	[0 to 25/0/1]
2-140-013	Error Status	Thic.Cal.3T-Befo.	ENG*	[0 to 25/0/1]
2-140-014	Error Status	Thic.Cal.4T-Befo.	ENG*	[0 to 25/0/1]
2-140-021	Error Status	LDP Cal.:Latest	ENG*	[0 to 25/0/1]
2-140-022	Error Status	LDP Cal.:2T-Befo.	ENG*	[0 to 25/0/1]
2-140-023	Error Status	LDP Cal.:3T-Befo.	ENG*	[0 to 25/0/1]
2-140-024	Error Status	LDP Cal.:4T-Befo.	ENG*	[0 to 25/0/1]
2-140-031	Error Status	IO Cal: Latest	ENG*	[0 to 25/0/1]
2-140-032	Error Status	IO Cal. 2T-Before	ENG*	[0 to 25/0/1]
2-140-033	Error Status	IO Cal. 3T-Before	ENG*	[0 to 25/0/1]
2-140-034	Error Status	IO Cal. 4T-Before	ENG*	[0 to 25/0/1]
2-150-001	Area Mag. Cor.	Bk: Area 1	ENG*	[-0.00001 to 0.00001/0/0.00001]
2-150-002	Area Mag. Cor.	Bk: Area 2	ENG*	[-0.00001 to 0.00001/0/0.00001]
2-150-003	Area Mag. Cor.	Bk: Area 3	ENG*	[-0.00001 to 0.00001/0/0.00001]
2-150-004	Area Mag. Cor.	Bk: Area 4	ENG*	[-0.00001 to 0.00001/0/0.00001]
2-150-005	Area Mag. Cor.	Bk: Area 5	ENG*	[-0.00001 to 0.00001/0/0.00001]
2-150-006	Area Mag. Cor.	Bk: Area 6	ENG*	[-0.00001 to 0.00001/0/0.00001]

3.SP Mode Tables

SP No.	Large Category	Small Category	ENG or CTL	[Min to Max/Init./Step]
2-150-007	Area Mag. Cor.	Bk: Area 7	ENG*	[-0.00001 to 0.00001/0/0.00001]
2-150-008	Area Mag. Cor.	Bk: Area 8	ENG*	[-0.00001 to 0.00001/0/0.00001]
2-150-009	Area Mag. Cor.	Bk: Area 9	ENG*	[-0.00001 to 0.00001/0/0.00001]
2-150-010	Area Mag. Cor.	Bk: Area 10	ENG*	[-0.00001 to 0.00001/0/0.00001]
2-150-011	Area Mag. Cor.	Ma: Area 1	ENG*	[-0.00001 to 0.00001/0/0.00001]
2-150-012	Area Mag. Cor.	Ma: Area 2	ENG*	[-0.00001 to 0.00001/0/0.00001]
2-150-013	Area Mag. Cor.	Ma: Area 3	ENG*	[-0.00001 to 0.00001/0/0.00001]
2-150-014	Area Mag. Cor.	Ma: Area 4	ENG*	[-0.00001 to 0.00001/0/0.00001]
2-150-015	Area Mag. Cor.	Ma: Area 5	ENG*	[-0.00001 to 0.00001/0/0.00001]
2-150-016	Area Mag. Cor.	Ma: Area 6	ENG*	[-0.00001 to 0.00001/0/0.00001]
2-150-017	Area Mag. Cor.	Ma: Area 7	ENG*	[-0.00001 to 0.00001/0/0.00001]
2-150-018	Area Mag. Cor.	Ma: Area 8	ENG*	[-0.00001 to 0.00001/0/0.00001]
2-150-019	Area Mag. Cor.	Ma: Area 9	ENG*	[-0.00001 to 0.00001/0/0.00001]
2-150-020	Area Mag. Cor.	Ma: Area 10	ENG*	[-0.00001 to 0.00001/0/0.00001]
2-150-021	Area Mag. Cor.	Cy: Area 1	ENG*	[-0.00001 to 0.00001/0/0.00001]
2-150-022	Area Mag. Cor.	Cy: Area 2	ENG*	[-0.00001 to 0.00001/0/0.00001]
2-150-023	Area Mag. Cor.	Cy: Area 3	ENG*	[-0.00001 to 0.00001/0/0.00001]
2-150-024	Area Mag. Cor.	Cy: Area 4	ENG*	[-0.00001 to 0.00001/0/0.00001]

## 3.SP Mode Tables

SP No.	Large Category	Small Category	ENG or CTL	[Min to Max/Init./Step]
2-150-025	Area Mag. Cor.	Cy: Area 5	ENG*	[-0.00001 to 0.00001/0/0.00001]
2-150-026	Area Mag. Cor.	Cy: Area 6	ENG*	[-0.00001 to 0.00001/0/0.00001]
2-150-027	Area Mag. Cor.	Cy: Area 7	ENG*	[-0.00001 to 0.00001/0/0.00001]
2-150-028	Area Mag. Cor.	Cy: Area 8	ENG*	[-0.00001 to 0.00001/0/0.00001]
2-150-029	Area Mag. Cor.	Cy: Area 9	ENG*	[-0.00001 to 0.00001/0/0.00001]
2-150-030	Area Mag. Cor.	Cy: Area 10	ENG*	[-0.00001 to 0.00001/0/0.00001]
2-150-031	Area Mag. Cor.	Ye: Area 1	ENG*	[-0.00001 to 0.00001/0/0.00001]
2-150-032	Area Mag. Cor.	Ye: Area 2	ENG*	[-0.00001 to 0.00001/0/0.00001]
2-150-033	Area Mag. Cor.	Ye: Area 3	ENG*	[-0.00001 to 0.00001/0/0.00001]
2-150-034	Area Mag. Cor.	Ye: Area 4	ENG*	[-0.00001 to 0.00001/0/0.00001]
2-150-035	Area Mag. Cor.	Ye: Area 5	ENG*	[-0.00001 to 0.00001/0/0.00001]
2-150-036	Area Mag. Cor.	Ye: Area 6	ENG*	[-0.00001 to 0.00001/0/0.00001]
2-150-037	Area Mag. Cor.	Ye: Area 7	ENG*	[-0.00001 to 0.00001/0/0.00001]
2-150-038	Area Mag. Cor.	Ye: Area 8	ENG*	[-0.00001 to 0.00001/0/0.00001]
2-150-039	Area Mag. Cor.	Ye: Area 9	ENG*	[-0.00001 to 0.00001/0/0.00001]
2-150-040	Area Mag. Cor.	Ye: Area 10	ENG*	[-0.00001 to 0.00001/0/0.00001]
2-181-002	Auto Pos. Adj.	Ma: M. Cor.: Dot	ENG*	[-1.42 to 1.42/0/0.01dot]
2-181-003	Auto Pos. Adj.	Cy: M. Cor.: Dot	ENG*	[-1.42 to 1.42/0/0.01dot]

### 3.SP Mode Tables

SP No.	Large Category	Small Category	ENG or CTL	[Min to Max/Init./Step]
2-181-004	Auto Pos. Adj.	Ye: M. Cor.: Dot	ENG*	[-1.42 to 1.42/0/0.01dot]
2-181-012	Auto Pos. Adj.	Bk: S. Cor.: Line	ENG*	[-236 to 236/0/1line]
2-181-013	Auto Pos. Adj.	Ma: S. Cor.: Line	ENG*	[-236 to 236/0/1line]
2-181-014	Auto Pos. Adj.	Cy: S. Cor.: Line	ENG*	[-236 to 236/0/1line]
2-181-015	Auto Pos. Adj.	Ye: S. Cor.: Line	ENG*	[-236 to 236/0/1line]
2-181-022	Auto Pos. Adj.	Ma: Main Mag Cor.	ENG*	[-0.00001 to 0.00001/0/0.00001]
2-181-023	Auto Pos. Adj.	Cy: Main Mag Cor.	ENG*	[-0.00001 to 0.00001/0/0.00001]
2-181-024	Auto Pos. Adj.	Ye: Main Mag Cor.	ENG*	[-0.00001 to 0.00001/0/0.00001]
2-182-002	L-Pos.Adj.Offset	Ma:M.Scan:LV1:Dot	ENG*	[-1.42 to 1.42/0/0.01dot]
2-182-003	L-Pos.Adj.Offset	Cy:M.Scan:LV1:Dot	ENG*	[-1.42 to 1.42/0/0.01dot]
2-182-004	L-Pos.Adj.Offset	Ye:M.Scan:LV1:Dot	ENG*	[-1.42 to 1.42/0/0.01dot]
2-182-005	L-Pos.Adj.Offset	Ma:M.Scan:LV2:Dot	ENG*	[-1.42 to 1.42/0/0.01dot]
2-182-006	L-Pos.Adj.Offset	Cy:M.Scan:LV2:Dot	ENG*	[-1.42 to 1.42/0/0.01dot]
2-182-007	L-Pos.Adj.Offset	Ye:M.Scan:LV2:Dot	ENG*	[-1.42 to 1.42/0/0.01dot]
2-182-008	L-Pos.Adj.Offset	Ma:M.Scan:LV3:Dot	ENG*	[-1.42 to 1.42/0/0.01dot]
2-182-009	L-Pos.Adj.Offset	Cy:M.Scan:LV3:Dot	ENG*	[-1.42 to 1.42/0/0.01dot]
2-182-010	L-Pos.Adj.Offset	Ye:M.Scan:LV3:Dot	ENG*	[-1.42 to 1.42/0/0.01dot]
2-182-011	L-Pos.Adj.Offset	Ma:M.Scan:LV4:Dot	ENG*	[-1.42 to 1.42/0/0.01dot]

## 3.SP Mode Tables

SP No.	Large Category	Small Category	ENG or CTL	[Min to Max/Init./Step]
2-182-012	L-Pos.Adj.Offset	Cy:M.Scan:LV4:Dot	ENG*	[-1.42 to 1.42/0/0.01dot]
2-182-013	L-Pos.Adj.Offset	Ye:M.Scan:LV4:Dot	ENG*	[-1.42 to 1.42/0/0.01dot]
2-182-022	L-Pos.Adj.Offset	Ma:S.Scan:LV1	ENG*	[-236 to 236/0/1line]
2-182-023	L-Pos.Adj.Offset	Cy:S.Scan:LV1	ENG*	[-236 to 236/0/1line]
2-182-024	L-Pos.Adj.Offset	Ye:S.Scan:LV1	ENG*	[-236 to 236/0/1line]
2-182-025	L-Pos.Adj.Offset	Ma:S.Scan:LV2	ENG*	[-236 to 236/0/1line]
2-182-026	L-Pos.Adj.Offset	Cy:S.Scan:LV2	ENG*	[-236 to 236/0/1line]
2-182-027	L-Pos.Adj.Offset	Ye:S.Scan:LV2	ENG*	[-236 to 236/0/1line]
2-182-028	L-Pos.Adj.Offset	Ma:S.Scan:LV3	ENG*	[-236 to 236/0/1line]
2-182-029	L-Pos.Adj.Offset	Cy:S.Scan:LV3	ENG*	[-236 to 236/0/1line]
2-182-030	L-Pos.Adj.Offset	Ye:S.Scan:LV3	ENG*	[-236 to 236/0/1line]
2-182-031	L-Pos.Adj.Offset	Ma:S.Scan:LV4	ENG*	[-236 to 236/0/1line]
2-182-032	L-Pos.Adj.Offset	Cy:S.Scan:LV4	ENG*	[-236 to 236/0/1line]
2-182-033	L-Pos.Adj.Offset	Ye:S.Scan:LV4	ENG*	[-236 to 236/0/1line]
2-183-001	L-Pos.Adj.Offset	Auto Adj. Clear	ENG	[0 to 1/0/1]
2-183-002	L-Pos.Adj.Offset	Manual Adj. Clear	ENG	[0 to 1/0/1]
2-184-001	ID Correct Data	LASER POWER K	ENG*	[0 to 255/0/1]
2-184-002	ID Correct Data	LASER POWER C	ENG*	[0 to 255/0/1]

### 3.SP Mode Tables

SP No.	Large Category	Small Category	ENG or CTL	[Min to Max/Init./Step]
2-184-003	ID Correct Data	LASER POWER M	ENG*	[0 to 255/0/1]
2-184-004	ID Correct Data	LASER POWER Y	ENG*	[0 to 255/0/1]
2-185-005	ColorShiftCorrect	Main C	ENG*	[0 to 65535/0/1]
2-185-006	ColorShiftCorrect	Sub C	ENG*	[0 to 65535/0/1]
2-185-007	ColorShiftCorrect	Equal C	ENG*	[0 to 65535/0/1]
2-185-008	ColorShiftCorrect	Main M	ENG*	[0 to 65535/0/1]
2-185-009	ColorShiftCorrect	Sub M	ENG*	[0 to 65535/0/1]
2-185-010	ColorShiftCorrect	Equal M	ENG*	[0 to 65535/0/1]
2-185-011	ColorShiftCorrect	Main Y	ENG*	[0 to 65535/0/1]
2-185-012	ColorShiftCorrect	Sub Y	ENG*	[0 to 65535/0/1]
2-185-013	ColorShiftCorrect	Equal Y	ENG*	[0 to 65535/0/1]
2-185-014	ColorShiftCorrect	Main C	ENG*	[0 to 65535/0/1]
2-185-015	ColorShiftCorrect	Sub C	ENG*	[0 to 65535/0/1]
2-185-016	ColorShiftCorrect	Equal:1 C	ENG*	[0 to 65535/0/1]
2-185-017	ColorShiftCorrect	Equal:2 C	ENG*	[0 to 65535/0/1]
2-185-018	ColorShiftCorrect	Equal:3 C	ENG*	[0 to 65535/0/1]
2-185-019	ColorShiftCorrect	Equal:4 C	ENG*	[0 to 65535/0/1]
2-185-020	ColorShiftCorrect	Main M	ENG*	[0 to 65535/0/1]

## 3.SP Mode Tables

SP No.	Large Category	Small Category	ENG or CTL	[Min to Max/Init./Step]
2-185-021	ColorShiftCorrect	Sub M	ENG*	[0 to 65535/0/1]
2-185-022	ColorShiftCorrect	Equal:1 M	ENG*	[0 to 65535/0/1]
2-185-023	ColorShiftCorrect	Equal:2 M	ENG*	[0 to 65535/0/1]
2-185-024	ColorShiftCorrect	Equal:3 M	ENG*	[0 to 65535/0/1]
2-185-025	ColorShiftCorrect	Equal:4 M	ENG*	[0 to 65535/0/1]
2-185-026	ColorShiftCorrect	Main Y	ENG*	[0 to 65535/0/1]
2-185-027	ColorShiftCorrect	Sub Y	ENG*	[0 to 65535/0/1]
2-185-028	ColorShiftCorrect	Equal:1 Y	ENG*	[0 to 65535/0/1]
2-185-029	ColorShiftCorrect	Equal:2 Y	ENG*	[0 to 65535/0/1]
2-185-030	ColorShiftCorrect	Equal:3 Y	ENG*	[0 to 65535/0/1]
2-185-031	ColorShiftCorrect	Equal:4 Y	ENG*	[0 to 65535/0/1]
2-186-032	LSU Timing	Main K	ENG*	[0 to 255/0/1]
2-186-033	LSU Timing	Main C	ENG*	[0 to 255/0/1]
2-186-034	LSU Timing	Main M	ENG*	[0 to 255/0/1]
2-186-035	LSU Timing	Main Y	ENG*	[0 to 255/0/1]
2-186-036	LSU Timing	Sub K	ENG*	[0 to 255/0/1]
2-186-037	LSU Timing	Sub C	ENG*	[0 to 255/0/1]
2-186-038	LSU Timing	Sub M	ENG*	[0 to 255/0/1]

### 3.SP Mode Tables

SP No.	Large Category	Small Category	ENG or CTL	[Min to Max/Init./Step]
2-186-039	LSU Timing	Sub Y	ENG*	[0 to 255/0/1]
2-310-001	Main Charge	MC AC:K	ENG*	[0 to 65535/0/1V]
2-310-002	Main Charge	MC AC:C	ENG*	[0 to 65535/0/1V]
2-310-003	Main Charge	MC AC:M	ENG*	[0 to 65535/0/1V]
2-310-004	Main Charge	MC AC:Y	ENG*	[0 to 65535/0/1V]
2-310-005	Main Charge	MC DC Std:K	ENG*	[0 to 65535/0/1V]
2-310-006	Main Charge	MC DC Std:C	ENG*	[0 to 65535/0/1V]
2-310-007	Main Charge	MC DC Std:M	ENG*	[0 to 65535/0/1V]
2-310-008	Main Charge	MC DC Std:Y	ENG*	[0 to 65535/0/1V]
2-310-009	Main Charge	MC DC 3/4:K	ENG*	[0 to 65535/0/1V]
2-310-010	Main Charge	MC DC 3/4:C	ENG*	[0 to 65535/0/1V]
2-310-011	Main Charge	MC DC 3/4:M	ENG*	[0 to 65535/0/1V]
2-310-012	Main Charge	MC DC 3/4:Y	ENG*	[0 to 65535/0/1V]
2-310-013	Main Charge	MC DC Half:K	ENG*	[0 to 65535/0/1V]
2-310-014	Main Charge	MC DC Half:C	ENG*	[0 to 65535/0/1V]
2-310-015	Main Charge	MC DC Half:M	ENG*	[0 to 65535/0/1V]
2-310-016	Main Charge	MC DC Half:Y	ENG*	[0 to 65535/0/1V]
2-310-017	Main Charge	MC DC Add Std:K	ENG*	[0 to 65535/0/1V]

## 3.SP Mode Tables

SP No.	Large Category	Small Category	ENG or CTL	[Min to Max/Init./Step]
2-310-018	Main Charge	MC DC Add Std:C	ENG*	[0 to 65535/0/1V]
2-310-019	Main Charge	MC DC Add Std:M	ENG*	[0 to 65535/0/1V]
2-310-020	Main Charge	MC DC Add Std:Y	ENG*	[0 to 65535/0/1V]
2-310-021	Main Charge	MC DC Add 3/4:K	ENG*	[0 to 65535/0/1V]
2-310-022	Main Charge	MC DC Add 3/4:C	ENG*	[0 to 65535/0/1V]
2-310-023	Main Charge	MC DC Add 3/4:M	ENG*	[0 to 65535/0/1V]
2-310-024	Main Charge	MC DC Add 3/4:Y	ENG*	[0 to 65535/0/1V]
2-310-025	Main Charge	MC DC Add Half:K	ENG*	[0 to 65535/0/1V]
2-310-026	Main Charge	MC DC Add Half:C	ENG*	[0 to 65535/0/1V]
2-310-027	Main Charge	MC DC Add Half:M	ENG*	[0 to 65535/0/1V]
2-310-028	Main Charge	MC DC Add Half:Y	ENG*	[0 to 65535/0/1V]
2-310-029	Main Charge	Charge Freq	ENG*	[0 to 65535/0/1Hz]
2-310-030	Main Charge	MC DC H Std:K	ENG*	[0 to 65535/0/1V]
2-310-031	Main Charge	MC DC H Std:C	ENG*	[0 to 65535/0/1V]
2-310-032	Main Charge	MC DC H Std:M	ENG*	[0 to 65535/0/1V]
2-310-033	Main Charge	MC DC H Std:Y	ENG*	[0 to 65535/0/1V]
2-310-034	Main Charge	MC DC Add H Std:K	ENG*	[0 to 65535/0/1V]
2-310-035	Main Charge	MC DC Add H Std:C	ENG*	[0 to 65535/0/1V]

### 3.SP Mode Tables

SP No.	Large Category	Small Category	ENG or CTL	[Min to Max/Init./Step]
2-310-036	Main Charge	MC DC Add H Std:M	ENG*	[0 to 65535/0/1V]
2-310-037	Main Charge	MC DC Add H Std:Y	ENG*	[0 to 655.3/0/0.1uA]
2-311-001	Trans Charge	Std	ENG*	[0 to 655.3/0/0.1uA]
2-311-002	Trans Charge	Half	ENG*	[0 to 655.3/0/0.1uA]
2-311-003	Trans Charge	3/4	ENG*	[0 to 655.3/0/0.1uA]
2-311-004	Trans Charge	H	ENG*	[0 to 655.3/0/0.1uA]
2-311-005	Trans Charge	Add K	ENG*	[0 to 655.3/0/0.1uA]
2-311-006	Trans Charge	Add C	ENG*	[0 to 655.3/0/0.1uA]
2-311-007	Trans Charge	Add M	ENG*	[0 to 655.3/0/0.1uA]
2-311-008	Trans Charge	Add Y	ENG*	[0 to 655.3/0/0.1uA]
2-311-009	Trans Charge	Add 2nd K	ENG*	[0 to 655.3/0/0.1uA]
2-311-010	Trans Charge	Add 2nd C	ENG*	[0 to 655.3/0/0.1uA]
2-311-011	Trans Charge	Add 2nd M	ENG*	[0 to 655.3/0/0.1uA]
2-311-012	Trans Charge	Add 2nd Y	ENG*	[0 to 655.3/0/0.1uA]
2-311-013	Trans Charge	Add H Ground K	ENG*	[0 to 655.3/0/0.1uA]
2-311-014	Trans Charge	Add H Ground C	ENG*	[0 to 655.3/0/0.1uA]
2-311-015	Trans Charge	Add H Ground M	ENG*	[0 to 655.3/0/0.1uA]
2-311-016	Trans Charge	Add H Ground Y	ENG*	[0 to 655.3/0/0.1uA]
2-311-	Trans Charge	Add H K	ENG*	[0 to 655.3/0/0.1uA]

## 3.SP Mode Tables

SP No.	Large Category	Small Category	ENG or CTL	[Min to Max/Init./Step]
017				
2-311-018	Trans Charge	Add H C	ENG*	[0 to 655.3/0/0.1uA]
2-311-019	Trans Charge	Add H M	ENG*	[0 to 655.3/0/0.1uA]
2-311-020	Trans Charge	Add H Y	ENG*	[0 to 655.3/0/0.1uA]
2-311-021	Trans Charge	Add 2nd H K	ENG*	[0 to 655.3/0/0.1uA]
2-311-022	Trans Charge	Add 2nd H C	ENG*	[0 to 655.3/0/0.1uA]
2-311-023	Trans Charge	Add 2nd H M	ENG*	[0 to 655.3/0/0.1uA]
2-311-024	Trans Charge	Add 2nd H Y	ENG*	[0 to 655.3/0/0.1uA]
2-312-001	Trans2 Charge	LN1 Std 1 160	ENG*	[0 to 15/0/0.1uA]
2-312-002	Trans2 Charge	LN1 Std 1 220	ENG*	[0 to 15/0/0.1uA]
2-312-003	Trans2 Charge	LN1 Std 2 160	ENG*	[0 to 15/0/0.1uA]
2-312-004	Trans2 Charge	LN1 Std 2 220	ENG*	[0 to 15/0/0.1uA]
2-312-005	Trans2 Charge	N2 N3 Std 1 160	ENG*	[0 to 15/0/0.1uA]
2-312-006	Trans2 Charge	N2 N3 Std 1 220	ENG*	[0 to 15/0/0.1uA]
2-312-007	Trans2 Charge	N2 N3 Std 2 160	ENG*	[0 to 15/0/0.1uA]
2-312-008	Trans2 Charge	N2 N3 Std 2 220	ENG*	[0 to 15/0/0.1uA]
2-312-009	Trans2 Charge	LN1-3 3/4 1 160	ENG*	[0 to 15/0/0.1uA]
2-312-010	Trans2 Charge	LN1-3 3/4 1 220	ENG*	[0 to 15/0/0.1uA]
2-312-	Trans2 Charge	LN1-3 3/4 2 160	ENG*	[0 to 15/0/0.1uA]

### 3.SP Mode Tables

SP No.	Large Category	Small Category	ENG or CTL	[Min to Max/Init./Step]
011				
2-312-012	Trans2 Charge	LN1-3 3/4 2 220	ENG*	[0 to 15/0/0.1uA]
2-312-013	Trans2 Charge	H1 3/4 1 160	ENG*	[0 to 15/0/0.1uA]
2-312-014	Trans2 Charge	H1 3/4 1 220	ENG*	[0 to 15/0/0.1uA]
2-312-015	Trans2 Charge	H1 3/4 2 160	ENG*	[0 to 15/0/0.1uA]
2-312-016	Trans2 Charge	H1 3/4 2 220	ENG*	[0 to 15/0/0.1uA]
2-312-017	Trans2 Charge	LN1-3 1/2 1 160	ENG*	[0 to 15/0/0.1uA]
2-312-018	Trans2 Charge	LN1-3 1/2 1 220	ENG*	[0 to 15/0/0.1uA]
2-312-019	Trans2 Charge	LN1-3 1/2 2 160	ENG*	[0 to 15/0/0.1uA]
2-312-020	Trans2 Charge	LN1-3 1/2 2 220	ENG*	[0 to 15/0/0.1uA]
2-312-021	Trans2 Charge	H1 1/2 1 160	ENG*	[0 to 15/0/0.1uA]
2-312-022	Trans2 Charge	H1 1/2 1 220	ENG*	[0 to 15/0/0.1uA]
2-312-023	Trans2 Charge	H1 1/2 2 160	ENG*	[0 to 15/0/0.1uA]
2-312-024	Trans2 Charge	H1 1/2 2 220	ENG*	[0 to 15/0/0.1uA]
2-312-025	Trans2 Charge	H2 H3 1/2 1 160	ENG*	[0 to 15/0/0.1uA]
2-312-026	Trans2 Charge	H2 H3 1/2 1 220	ENG*	[0 to 15/0/0.1uA]
2-312-027	Trans2 Charge	H2 H3 1/2 2 160	ENG*	[0 to 15/0/0.1uA]
2-312-028	Trans2 Charge	H2 H3 1/2 2 220	ENG*	[0 to 15/0/0.1uA]
2-312-	Trans2 Charge	extH 1/2 1 160	ENG*	[0 to 15/0/0.1uA]

## 3.SP Mode Tables

SP No.	Large Category	Small Category	ENG or CTL	[Min to Max/Init./Step]
029				
2-312-030	Trans2 Charge	extH 1/2 1 220	ENG*	[0 to 15/0/0.1uA]
2-312-031	Trans2 Charge	LN1 H 1 160	ENG*	[0 to 15/0/0.1uA]
2-312-032	Trans2 Charge	LN1 H 1 220	ENG*	[0 to 15/0/0.1uA]
2-312-033	Trans2 Charge	LN1 H 2 160	ENG*	[0 to 15/0/0.1uA]
2-312-034	Trans2 Charge	LN1 H 2 220	ENG*	[0 to 15/0/0.1uA]
2-312-035	Trans2 Charge	N2 N3 H 1 160	ENG*	[0 to 15/0/0.1uA]
2-312-036	Trans2 Charge	N2 N3 H 1 220	ENG*	[0 to 15/0/0.1uA]
2-312-037	Trans2 Charge	N2 N3 H 2 160	ENG*	[0 to 15/0/0.1uA]
2-312-038	Trans2 Charge	N2 N3 H 2 220	ENG*	[0 to 15/0/0.1uA]
2-312-039	Trans2 Charge	H1 H 1 160	ENG*	[0 to 15/0/0.1uA]
2-312-040	Trans2 Charge	H1 H 1 220	ENG*	[0 to 15/0/0.1uA]
2-312-041	Trans2 Charge	H1 H 2 160	ENG*	[0 to 15/0/0.1uA]
2-312-042	Trans2 Charge	H1 H 2 220	ENG*	[0 to 15/0/0.1uA]
2-312-043	Trans2 Charge	H2 H3 H 1 160	ENG*	[0 to 15/0/0.1uA]
2-312-044	Trans2 Charge	H2 H3 H 1 220	ENG*	[0 to 15/0/0.1uA]
2-312-045	Trans2 Charge	H2 H3 H 2 160	ENG*	[0 to 15/0/0.1uA]
2-312-046	Trans2 Charge	H2 H3 H 2 220	ENG*	[0 to 15/0/0.1uA]
2-312-	Trans2 Charge	extH H 1 160	ENG*	[0 to 150/0/0.1uA]

### 3.SP Mode Tables

SP No.	Large Category	Small Category	ENG or CTL	[Min to Max/Init./Step]
047				
2-312-048	Trans2 Charge	extH H 1 220	ENG*	[0 to 150/0/0.1uA]
2-312-049	Trans2 Charge	LN1-3 Std 1 K 160	ENG*	[0 to 150/0/0.1uA]
2-312-050	Trans2 Charge	LN1-3 Std 1 K 220	ENG*	[0 to 150/0/0.1uA]
2-312-051	Trans2 Charge	LN1-3 Std 2 K 160	ENG*	[0 to 150/0/0.1uA]
2-312-052	Trans2 Charge	LN1-3 Std 2 K 220	ENG*	[0 to 150/0/0.1uA]
2-312-053	Trans2 Charge	H1 3/4 1 K 160	ENG*	[0 to 150/0/0.1uA]
2-312-054	Trans2 Charge	H1 3/4 1 K 220	ENG*	[0 to 150/0/0.1uA]
2-312-055	Trans2 Charge	H1 3/4 2 K 160	ENG*	[0 to 150/0/0.1uA]
2-312-056	Trans2 Charge	H1 3/4 2 K 220	ENG*	[0 to 150/0/0.1uA]
2-312-057	Trans2 Charge	H2-3 Half 1 K 160	ENG*	[0 to 150/0/0.1uA]
2-312-058	Trans2 Charge	H2-3 Half 1 K 220	ENG*	[0 to 150/0/0.1uA]
2-312-059	Trans2 Charge	H2-3 Half 2 K 160	ENG*	[0 to 150/0/0.1uA]
2-312-060	Trans2 Charge	H2-3 Half 2 K 220	ENG*	[0 to 150/0/0.1uA]
2-312-061	Trans2 Charge	LN1-3 H 1 K 160	ENG*	[0 to 150/0/0.1uA]
2-312-062	Trans2 Charge	LN1-3 H 1 K 220	ENG*	[0 to 150/0/0.1uA]
2-312-063	Trans2 Charge	LN1-3 H 2 K 160	ENG*	[0 to 150/0/0.1uA]
2-312-064	Trans2 Charge	LN1-3 H 2 K 220	ENG*	[0 to 150/0/0.1uA]
2-312-	Trans2 Charge	H1 H 1 K 160	ENG*	[0 to 150/0/0.1uA]

## 3.SP Mode Tables

SP No.	Large Category	Small Category	ENG or CTL	[Min to Max/Init./Step]
065				
2-312-066	Trans2 Charge	H1 H 1 K 220	ENG*	[0 to 150/0/0.1uA]
2-312-067	Trans2 Charge	H1 H 2 K 160	ENG*	[0 to 150/0/0.1uA]
2-312-068	Trans2 Charge	H1 H 2 K 220	ENG*	[0 to 150/0/0.1uA]
2-312-069	Trans2 Charge	H2 H3 H 1 K 160	ENG*	[0 to 150/0/0.1uA]
2-312-070	Trans2 Charge	H2 H3 H 1 K 220	ENG*	[0 to 150/0/0.1uA]
2-312-071	Trans2 Charge	H2 H3 H 2 K 160	ENG*	[0 to 150/0/0.1uA]
2-312-072	Trans2 Charge	H2 H3 H 2 K 220	ENG*	[0 to 150/0/0.1uA]
2-313-001	MidTransClean	A Std	ENG*	[0 to 65535/0/1V]
2-313-002	MidTransClean	A 3/4	ENG*	[0 to 65535/0/1V]
2-313-003	MidTransClean	A Half	ENG*	[0 to 65535/0/1V]
2-313-004	MidTransClean	A H	ENG*	[0 to 65535/0/1V]
2-313-005	MidTransClean	B Std	ENG*	[0 to 65535/0/1V]
2-313-006	MidTransClean	B 3/4	ENG*	[0 to 65535/0/1V]
2-313-007	MidTransClean	B Half	ENG*	[0 to 65535/0/1V]
2-313-008	MidTransClean	B H	ENG*	[0 to 65535/0/1V]
2-313-009	MidTransClean	C Std	ENG*	[0 to 65535/0/1V]
2-313-010	MidTransClean	C 3/4	ENG*	[0 to 65535/0/1V]
2-313-	MidTransClean	C Half	ENG*	[0 to 65535/0/1V]

### 3.SP Mode Tables

SP No.	Large Category	Small Category	ENG or CTL	[Min to Max/Init./Step]
011				
2-313-012	MidTransClean	C H	ENG*	[0 to 65535/0/1V]
2-314-001	Dev Charge	Dev Sleeve DC K	ENG*	[0 to 65535/0/1V]
2-314-002	Dev Charge	Dev Sleeve DC C	ENG*	[0 to 65535/0/1V]
2-314-003	Dev Charge	Dev Sleeve DC M	ENG*	[0 to 65535/0/1V]
2-314-004	Dev Charge	Dev Sleeve DC Y	ENG*	[0 to 65535/0/1V]
2-314-005	Dev Charge	Dev Sleeve AC K	ENG*	[0 to 65535/0/1V]
2-314-006	Dev Charge	Dev Sleeve AC C	ENG*	[0 to 65535/0/1V]
2-314-007	Dev Charge	Dev Sleeve AC M	ENG*	[0 to 65535/0/1V]
2-314-008	Dev Charge	Dev Sleeve AC Y	ENG*	[0 to 65535/0/1V]
2-314-009	Dev Charge	De Mug DC K	ENG*	[0 to 65535/0/1V]
2-314-010	Dev Charge	De Mug DC C	ENG*	[0 to 65535/0/1V]
2-314-011	Dev Charge	De Mug DC M	ENG*	[0 to 65535/0/1V]
2-314-012	Dev Charge	De Mug DC Y	ENG*	[0 to 65535/0/1V]
2-314-013	Dev Charge	Dev Sleeve F K	ENG*	[0 to 65535/0/1V]
2-314-014	Dev Charge	Dev Sleeve F CMY	ENG*	[0 to 65535/0/1V]
2-314-015	Dev Charge	Dev Sleeve Duty K	ENG	[0 to 100/0/1%]
2-314-016	Dev Charge	Dev Sleeve Duty C	ENG*	[0 to 100/0/1%]
2-314-	Dev Charge	Dev Sleeve Duty M	ENG	[0 to 100/0/1%]

### 3.SP Mode Tables

SP No.	Large Category	Small Category	ENG or CTL	[Min to Max/Init./Step]
017				
2-314-018	Dev Charge	Dev Sleeve Duty Y	ENG	[0 to 100/0/1%]

### Main SP Tables-3

SP3-XXX (Process)

SP No.	Large Category	Small Category	ENG or CTL	[Min to Max/Init./Step]
3-014-001	IBACC OK?	History:Last	ENG*	[0 to 9999/0/1]
3-014-002	IBACC OK?	History:Last 2	ENG*	[0 to 9999/0/1]
3-014-003	IBACC OK?	History:Last 3	ENG*	[0 to 9999/0/1]
3-014-004	IBACC OK?	History:Last 4	ENG*	[0 to 9999/0/1]
3-014-005	IBACC OK?	History:Last 5	ENG*	[0 to 9999/0/1]
3-014-006	IBACC OK?	History:Last 6	ENG*	[0 to 9999/0/1]
3-014-007	IBACC OK?	History:Last 7	ENG*	[0 to 9999/0/1]
3-014-008	IBACC OK?	History:Last 8	ENG*	[0 to 9999/0/1]
3-014-009	IBACC OK?	History:Last 9	ENG*	[0 to 9999/0/1]
3-014-010	IBACC OK?	History:Last 10	ENG*	[0 to 9999/0/1]
3-850-001	filming prev	mode select	ENG*	[0 to 2/1/1]
3-850-002	filming prev	extra time	ENG*	[0 to 220/30/1sec]
3-900-001	Toner Install Mode	On	ENG	[0 to 1/0/1]
3-900-002	Toner Install Mode	Off	ENG	[0 to 1/0/1]
3-901-001	Drum Refresh		ENG	[0 to 1/0/1]
3-902-001	Auto Drum Refresh		ENG*	[0 to 3/2/1]
3-903-001	Altitude Adjust		ENG*	[0 to 3/0/1]
3-904-001	MainCharger Output		ENG*	[1 to 5/3/1]
3-905-001	Development Cleaning		ENG	[0 to 1/0/1]
3-921-001	High Gloss Print		ENG*	[0 to 1/0/1]
3-922-001	Silent Mode		ENG*	[0 to 1/0/1]
3-924-001	Color Regist	Normal	ENG	[0 to 1/0/1]
3-925-001	Color Regist	Advanced	ENG	[0 to 1/0/1]

## Main SP Tables-4

### SP4-XXX

SP No.	Large Category	Small Category	ENG or CTL	[Min to Max/Init./Step]
4-201-001	LoCPP edge lv:K	600dpi 2bit edge1	ENG*	[0 to 15/12/1]
4-201-002	LoCPP edge lv:K	600dpi 2bit edge2	ENG*	[0 to 15/12/1]
4-201-003	LoCPP edge lv:K	600dpi 4bit edge1	ENG*	[0 to 15/12/1]
4-201-004	LoCPP edge lv:K	600dpi 4bit edge2	ENG*	[0 to 15/12/1]
4-201-005	LoCPP edge lv:K	600dpi 1bit edge1	ENG*	[0 to 15/12/1]
4-201-006	LoCPP edge lv:K	600dpi 1bit edge2	ENG*	[0 to 15/12/1]
4-201-011	LoCPP edge lv:K	1200dpi1bitEdge12	ENG*	[0 to 15/12/1]
4-201-012	LoCPP edge lv:K	1200dpi1bitEdge34	ENG*	[0 to 15/12/1]
4-201-013	LoCPP edge lv:K	1200dpi2bitEdge12	ENG*	[0 to 15/15/1]
4-201-014	LoCPP edge lv:K	1200dpi2bitEdge34	ENG*	[0 to 15/15/1]
4-202-001	LoCPP edge lv:C	600dpi 2bit edge1	ENG*	[0 to 15/15/1]
4-202-002	LoCPP edge lv:C	600dpi 2bit edge2	ENG*	[0 to 15/15/1]
4-202-003	LoCPP edge lv:C	600dpi 4bit edge1	ENG*	[0 to 15/15/1]
4-202-004	LoCPP edge lv:C	600dpi 4bit edge2	ENG*	[0 to 15/15/1]
4-202-005	LoCPP edge lv:C	600dpi 1bit edge1	ENG*	[0 to 15/15/1]
4-202-006	LoCPP edge lv:C	600dpi 1bit edge2	ENG*	[0 to 15/15/1]
4-202-	LoCPP edge	1200dpi1bitEdge12	ENG*	[0 to 15/15/1]

### 3.SP Mode Tables

SP No.	Large Category	Small Category	ENG or CTL	[Min to Max/Init./Step]
011	lv:C			
4-202-012	LoCPP edge lv:C	1200dpi1bitEdge34	ENG*	[0 to 15/15/1]
4-202-013	LoCPP edge lv:C	1200dpi2bitEdge12	ENG*	[0 to 15/15/1]
4-202-014	LoCPP edge lv:C	1200dpi2bitEdge34	ENG*	[0 to 15/15/1]
4-203-001	LoCPP edge lv:M	600dpi 2bit edge1	ENG*	[0 to 15/15/1]
4-203-002	LoCPP edge lv:M	600dpi 2bit edge2	ENG*	[0 to 15/15/1]
4-203-003	LoCPP edge lv:M	600dpi 4bit edge1	ENG*	[0 to 15/15/1]
4-203-004	LoCPP edge lv:M	600dpi 4bit edge2	ENG*	[0 to 15/15/1]
4-203-005	LoCPP edge lv:M	600dpi 1bit edge1	ENG*	[0 to 15/15/1]
4-203-006	LoCPP edge lv:M	600dpi 1bit edge2	ENG*	[0 to 15/15/1]
4-203-011	LoCPP edge lv:M	1200dpi1bitEdge12	ENG*	[0 to 15/15/1]
4-203-012	LoCPP edge lv:M	1200dpi1bitEdge34	ENG*	[0 to 15/15/1]
4-203-013	LoCPP edge lv:M	1200dpi2bitEdge12	ENG*	[0 to 15/15/1]
4-203-014	LoCPP edge lv:M	1200dpi2bitEdge34	ENG*	[0 to 15/15/1]
4-204-001	LoCPP edge lv:Y	600dpi 2bit edge1	ENG*	[0 to 15/15/1]
4-204-002	LoCPP edge lv:Y	600dpi 2bit edge2	ENG*	[0 to 15/15/1]
4-204-003	LoCPP edge lv:Y	600dpi 4bit edge1	ENG*	[0 to 15/15/1]
4-204-004	LoCPP edge lv:Y	600dpi 4bit edge2	ENG*	[0 to 15/15/1]
4-204-	LoCPP edge	600dpi 1bit edge1	ENG*	[0 to 15/15/1]

SP No.	Large Category	Small Category	ENG or CTL	[Min to Max/Init./Step]
005	lv:Y			
4-204-006	LoCPP edge lv:Y	600dpi 1bit edge2	ENG*	[0 to 15/15/1]
4-204-011	LoCPP edge lv:Y	1200dpi1bitEdge12	ENG*	[0 to 15/15/1]
4-204-012	LoCPP edge lv:Y	1200dpi1bitEdge34	ENG*	[0 to 15/15/1]
4-204-013	LoCPP edge lv:Y	1200dpi2bitEdge12	ENG*	[0 to 15/15/1]
4-204-014	LoCPP edge lv:Y	1200dpi2bitEdge34	ENG*	[0 to 15/15/1]
4-520-001	IBACC:Det Value	Latest:K_P1	ENG*	[0 to 1023/0/1]
4-520-002	IBACC:Det Value	Latest:K_P2	ENG*	[0 to 1023/0/1]
4-520-003	IBACC:Det Value	Latest:K_P3	ENG*	[0 to 1023/0/1]
4-520-004	IBACC:Det Value	Latest:K_P4	ENG*	[0 to 1023/0/1]
4-520-005	IBACC:Det Value	Latest:K_P5	ENG*	[0 to 1023/0/1]
4-520-006	IBACC:Det Value	Latest:K_P6	ENG*	[0 to 1023/0/1]
4-520-007	IBACC:Det Value	Latest:K_P7	ENG*	[0 to 1023/0/1]
4-520-008	IBACC:Det Value	Latest:K_P8	ENG*	[0 to 1023/0/1]
4-520-021	IBACC:Det Value	Latest:C_P1	ENG*	[0 to 1023/0/1]
4-520-022	IBACC:Det Value	Latest:C_P2	ENG*	[0 to 1023/0/1]
4-520-023	IBACC:Det Value	Latest:C_P3	ENG*	[0 to 1023/0/1]
4-520-024	IBACC:Det Value	Latest:C_P4	ENG*	[0 to 1023/0/1]
4-520-	IBACC:Det	Latest:C_P5	ENG*	[0 to 1023/0/1]

### 3.SP Mode Tables

SP No.	Large Category	Small Category	ENG or CTL	[Min to Max/Init./Step]
025	Value			
4-520-026	IBACC:Det Value	Latest:C_P6	ENG*	[0 to 1023/0/1]
4-520-027	IBACC:Det Value	Latest:C_P7	ENG*	[0 to 1023/0/1]
4-520-028	IBACC:Det Value	Latest:C_P8	ENG*	[0 to 1023/0/1]
4-520-041	IBACC:Det Value	Latest:M_P1	ENG*	[0 to 1023/0/1]
4-520-042	IBACC:Det Value	Latest:M_P2	ENG*	[0 to 1023/0/1]
4-520-043	IBACC:Det Value	Latest:M_P3	ENG*	[0 to 1023/0/1]
4-520-044	IBACC:Det Value	Latest:M_P4	ENG*	[0 to 1023/0/1]
4-520-045	IBACC:Det Value	Latest:M_P5	ENG*	[0 to 1023/0/1]
4-520-046	IBACC:Det Value	Latest:M_P6	ENG*	[0 to 1023/0/1]
4-520-047	IBACC:Det Value	Latest:M_P7	ENG*	[0 to 1023/0/1]
4-520-048	IBACC:Det Value	Latest:M_P8	ENG*	[0 to 1023/0/1]
4-520-061	IBACC:Det Value	Latest:Y_P1	ENG*	[0 to 1023/0/1]
4-520-062	IBACC:Det Value	Latest:Y_P2	ENG*	[0 to 1023/0/1]
4-520-063	IBACC:Det Value	Latest:Y_P3	ENG*	[0 to 1023/0/1]
4-520-064	IBACC:Det Value	Latest:Y_P4	ENG*	[0 to 1023/0/1]
4-520-065	IBACC:Det Value	Latest:Y_P5	ENG*	[0 to 1023/0/1]
4-520-066	IBACC:Det Value	Latest:Y_P6	ENG*	[0 to 1023/0/1]
4-520-	IBACC:Det	Latest:Y_P7	ENG*	[0 to 1023/0/1]

## 3.SP Mode Tables

SP No.	Large Category	Small Category	ENG or CTL	[Min to Max/Init./Step]
067	Value			
4-520-068	IBACC:Det Value	Latest:Y_P8	ENG*	[0 to 1023/0/1]
4-520-101	IBACC:Det Value	Previous:K_P1	ENG*	[0 to 1023/0/1]
4-520-102	IBACC:Det Value	Previous:K_P2	ENG*	[0 to 1023/0/1]
4-520-103	IBACC:Det Value	Previous:K_P3	ENG*	[0 to 1023/0/1]
4-520-104	IBACC:Det Value	Previous:K_P4	ENG*	[0 to 1023/0/1]
4-520-105	IBACC:Det Value	Previous:K_P5	ENG*	[0 to 1023/0/1]
4-520-106	IBACC:Det Value	Previous:K_P6	ENG*	[0 to 1023/0/1]
4-520-107	IBACC:Det Value	Previous:K_P7	ENG*	[0 to 1023/0/1]
4-520-108	IBACC:Det Value	Previous:K_P8	ENG*	[0 to 1023/0/1]
4-520-121	IBACC:Det Value	Previous:C_P1	ENG*	[0 to 1023/0/1]
4-520-122	IBACC:Det Value	Previous:C_P2	ENG*	[0 to 1023/0/1]
4-520-123	IBACC:Det Value	Previous:C_P3	ENG*	[0 to 1023/0/1]
4-520-124	IBACC:Det Value	Previous:C_P4	ENG*	[0 to 1023/0/1]
4-520-125	IBACC:Det Value	Previous:C_P5	ENG*	[0 to 1023/0/1]
4-520-126	IBACC:Det Value	Previous:C_P6	ENG*	[0 to 1023/0/1]
4-520-127	IBACC:Det Value	Previous:C_P7	ENG*	[0 to 1023/0/1]
4-520-128	IBACC:Det Value	Previous:C_P8	ENG*	[0 to 1023/0/1]
4-520-	IBACC:Det	Previous:M_P1	ENG*	[0 to 1023/0/1]

### 3.SP Mode Tables

SP No.	Large Category	Small Category	ENG or CTL	[Min to Max/Init./Step]
141	Value			
4-520-142	IBACC:Det Value	Previous:M_P2	ENG*	[0 to 1023/0/1]
4-520-143	IBACC:Det Value	Previous:M_P3	ENG*	[0 to 1023/0/1]
4-520-144	IBACC:Det Value	Previous:M_P4	ENG*	[0 to 1023/0/1]
4-520-145	IBACC:Det Value	Previous:M_P5	ENG*	[0 to 1023/0/1]
4-520-146	IBACC:Det Value	Previous:M_P6	ENG*	[0 to 1023/0/1]
4-520-147	IBACC:Det Value	Previous:M_P7	ENG*	[0 to 1023/0/1]
4-520-148	IBACC:Det Value	Previous:M_P8	ENG*	[0 to 1023/0/1]
4-520-161	IBACC:Det Value	Previous:Y_P1	ENG*	[0 to 1023/0/1]
4-520-162	IBACC:Det Value	Previous:Y_P2	ENG*	[0 to 1023/0/1]
4-520-163	IBACC:Det Value	Previous:Y_P3	ENG*	[0 to 1023/0/1]
4-520-164	IBACC:Det Value	Previous:Y_P4	ENG*	[0 to 1023/0/1]
4-520-165	IBACC:Det Value	Previous:Y_P5	ENG*	[0 to 1023/0/1]
4-520-166	IBACC:Det Value	Previous:Y_P6	ENG*	[0 to 1023/0/1]
4-520-167	IBACC:Det Value	Previous:Y_P7	ENG*	[0 to 1023/0/1]
4-520-168	IBACC:Det Value	Previous:Y_P8	ENG*	[0 to 1023/0/1]
4-700-001	Calibration Result1	Result1-1	ENG	[0x00000000 to 0xFFFFFFFF/0x00000000/1]
4-700-002	Calibration Result1	Result1-2	ENG	[0x00000000 to 0xFFFFFFFF/0x00000000/1]
4-700-	Calibration	Result1-3	ENG	[0x00000000 to

## 3.SP Mode Tables

SP No.	Large Category	Small Category	ENG or CTL	[Min to Max/Init./Step]
003	Result1			0xFFFFFFFF/0x00000000/1]
4-700-004	Calibration Result1	Result1-4	ENG	[0x00000000 to 0xFFFFFFFF/0x00000000/1]
4-700-005	Calibration Result1	Result1-5	ENG	[0x00000000 to 0xFFFFFFFF/0x00000000/1]
4-700-006	Calibration Result1	Result1-6	ENG	[0x00000000 to 0xFFFFFFFF/0x00000000/1]
4-700-007	Calibration Result1	Result1-7	ENG	[0x00000000 to 0xFFFFFFFF/0x00000000/1]
4-700-008	Calibration Result1	Result1-8	ENG	[0x00000000 to 0xFFFFFFFF/0x00000000/1]
4-700-009	Calibration Result1	Result1-9	ENG	[0x00000000 to 0xFFFFFFFF/0x00000000/1]
4-700-010	Calibration Result1	Result1-10	ENG	[0x00000000 to 0xFFFFFFFF/0x00000000/1]
4-700-011	Calibration Result1	Result1-11	ENG	[0x00000000 to 0xFFFFFFFF/0x00000000/1]
4-700-012	Calibration Result1	Result1-12	ENG	[0x00000000 to 0xFFFFFFFF/0x00000000/1]
4-700-013	Calibration Result1	Result1-13	ENG	[0x00000000 to 0xFFFFFFFF/0x00000000/1]
4-700-014	Calibration Result1	Result1-14	ENG	[0x00000000 to 0xFFFFFFFF/0x00000000/1]
4-700-015	Calibration Result1	Result1-15	ENG	[0x00000000 to 0xFFFFFFFF/0x00000000/1]
4-700-016	Calibration Result1	Result1-16	ENG	[0x00000000 to 0xFFFFFFFF/0x00000000/1]
4-700-017	Calibration Result1	Result1-17	ENG	[0x00000000 to 0xFFFFFFFF/0x00000000/1]
4-700-018	Calibration Result1	Result1-18	ENG	[0x00000000 to 0xFFFFFFFF/0x00000000/1]
4-701-001	Calibration Record	Record1-1	ENG	[0x00000000 to 0xFFFFFFFF/0x00000000/1]
4-701-002	Calibration Record	Record1-2	ENG	[0x00000000 to 0xFFFFFFFF/0x00000000/1]
4-701-	Calibration	Record1-3	ENG	[0x00000000 to

### 3.SP Mode Tables

SP No.	Large Category	Small Category	ENG or CTL	[Min to Max/Init./Step]
003	Record			0xFFFFFFFF/0x00000000/1]
4-701-004	Calibration Record	Record1-4	ENG	[0x00000000 to 0xFFFFFFFF/0x00000000/1]
4-701-005	Calibration Record	Record1-5	ENG	[0x00000000 to 0xFFFFFFFF/0x00000000/1]
4-701-006	Calibration Record	Record1-6	ENG	[0x00000000 to 0xFFFFFFFF/0x00000000/1]
4-702-001	Calibration Result2	Result2-1	ENG	[0x00000000 to 0xFFFFFFFF/0x00000000/1]
4-702-002	Calibration Result2	Result2-2	ENG	[0x00000000 to 0xFFFFFFFF/0x00000000/1]
4-702-003	Calibration Result2	Result2-3	ENG	[0x00000000 to 0xFFFFFFFF/0x00000000/1]
4-702-004	Calibration Result2	Result2-4	ENG	[0x00000000 to 0xFFFFFFFF/0x00000000/1]
4-702-005	Calibration Result2	Result2-5	ENG	[0x00000000 to 0xFFFFFFFF/0x00000000/1]
4-702-006	Calibration Result2	Result2-6	ENG	[0x00000000 to 0xFFFFFFFF/0x00000000/1]
4-702-007	Calibration Result2	Result2-7	ENG	[0x00000000 to 0xFFFFFFFF/0x00000000/1]
4-702-008	Calibration Result2	Result2-8	ENG	[0x00000000 to 0xFFFFFFFF/0x00000000/1]
4-702-009	Calibration Result2	Result2-9	ENG	[0x00000000 to 0xFFFFFFFF/0x00000000/1]
4-702-010	Calibration Result2	Result2-10	ENG	[0x00000000 to 0xFFFFFFFF/0x00000000/1]
4-703-001	Calibration Result3	Result3-1	ENG	[0x00000000 to 0xFFFFFFFF/0x00000000/1]
4-703-002	Calibration Result3	Result3-2	ENG	[0x00000000 to 0xFFFFFFFF/0x00000000/1]
4-703-003	Calibration Result3	Result3-3	ENG	[0x00000000 to 0xFFFFFFFF/0x00000000/1]
4-703-004	Calibration Result3	Result3-4	ENG	[0x00000000 to 0xFFFFFFFF/0x00000000/1]
4-703-005	Calibration	Result3-5	ENG	[0x00000000 to

## 3.SP Mode Tables

SP No.	Large Category	Small Category	ENG or CTL	[Min to Max/Init./Step]
005	Result3			0xFFFFFFFF/0x00000000/1]
4-703-006	Calibration Result3	Result3-6	ENG	[0x00000000 to 0xFFFFFFFF/0x00000000/1]
4-703-007	Calibration Result3	Result3-7	ENG	[0x00000000 to 0xFFFFFFFF/0x00000000/1]
4-703-008	Calibration Result3	Result3-8	ENG	[0x00000000 to 0xFFFFFFFF/0x00000000/1]
4-703-009	Calibration Result3	Result3-9	ENG	[0x00000000 to 0xFFFFFFFF/0x00000000/1]
4-703-010	Calibration Result3	Result3-10	ENG	[0x00000000 to 0xFFFFFFFF/0x00000000/1]
4-703-011	Calibration Result3	Result3-11	ENG	[0x00000000 to 0xFFFFFFFF/0x00000000/1]
4-703-012	Calibration Result3	Result3-12	ENG	[0x00000000 to 0xFFFFFFFF/0x00000000/1]
4-704-001	Calibration Result4	Result4-1	ENG	[0x00000000 to 0xFFFFFFFF/0x00000000/1]
4-704-002	Calibration Result4	Result4-2	ENG	[0x00000000 to 0xFFFFFFFF/0x00000000/1]
4-704-003	Calibration Result4	Result4-3	ENG	[0x00000000 to 0xFFFFFFFF/0x00000000/1]
4-704-004	Calibration Result4	Result4-4	ENG	[0x00000000 to 0xFFFFFFFF/0x00000000/1]
4-704-005	Calibration Result4	Result4-5	ENG	[0x00000000 to 0xFFFFFFFF/0x00000000/1]
4-704-006	Calibration Result4	Result4-6	ENG	[0x00000000 to 0xFFFFFFFF/0x00000000/1]
4-704-007	Calibration Result4	Result4-7	ENG	[0x00000000 to 0xFFFFFFFF/0x00000000/1]
4-704-008	Calibration Result4	Result4-8	ENG	[0x00000000 to 0xFFFFFFFF/0x00000000/1]
4-704-009	Calibration Result4	Result4-9	ENG	[0x00000000 to 0xFFFFFFFF/0x00000000/1]
4-704-010	Calibration Result4	Result4-10	ENG	[0x00000000 to 0xFFFFFFFF/0x00000000/1]
4-704-	Calibration	Result4-11	ENG	[0x00000000 to

### 3.SP Mode Tables

SP No.	Large Category	Small Category	ENG or CTL	[Min to Max/Init./Step]
011	Result4			0xFFFFFFFF/0x00000000/1]
4-704-012	Calibration Result4	Result4-12	ENG	[0x00000000 to 0xFFFFFFFF/0x00000000/1]
4-704-013	Calibration Result4	Result4-13	ENG	[0x00000000 to 0xFFFFFFFF/0x00000000/1]
4-704-014	Calibration Result4	Result4-14	ENG	[0x00000000 to 0xFFFFFFFF/0x00000000/1]
4-704-015	Calibration Result4	Result4-15	ENG	[0x00000000 to 0xFFFFFFFF/0x00000000/1]
4-704-016	Calibration Result4	Result4-16	ENG	[0x00000000 to 0xFFFFFFFF/0x00000000/1]
4-705-001	Calibration Result5	Result5-1	ENG	[0x00000000 to 0xFFFFFFFF/0x00000000/1]
4-705-002	Calibration Result5	Result5-2	ENG	[0x00000000 to 0xFFFFFFFF/0x00000000/1]
4-705-003	Calibration Result5	Result5-3	ENG	[0x00000000 to 0xFFFFFFFF/0x00000000/1]
4-705-004	Calibration Result5	Result5-4	ENG	[0x00000000 to 0xFFFFFFFF/0x00000000/1]
4-705-005	Calibration Result5	Result5-5	ENG	[0x00000000 to 0xFFFFFFFF/0x00000000/1]
4-705-006	Calibration Result5	Result5-6	ENG	[0x00000000 to 0xFFFFFFFF/0x00000000/1]
4-705-007	Calibration Result5	Result5-7	ENG	[0x00000000 to 0xFFFFFFFF/0x00000000/1]
4-705-008	Calibration Result5	Result5-8	ENG	[0x00000000 to 0xFFFFFFFF/0x00000000/1]
4-705-009	Calibration Result5	Result5-9	ENG	[0x00000000 to 0xFFFFFFFF/0x00000000/1]
4-705-010	Calibration Result5	Result5-10	ENG	[0x00000000 to 0xFFFFFFFF/0x00000000/1]
4-705-011	Calibration Result5	Result5-11	ENG	[0x00000000 to 0xFFFFFFFF/0x00000000/1]
4-705-012	Calibration Result5	Result5-12	ENG	[0x00000000 to 0xFFFFFFFF/0x00000000/1]
4-705-	Calibration	Result5-13	ENG	[0x00000000 to

SP No.	Large Category	Small Category	ENG or CTL	[Min to Max/Init./Step]
013	Result5			0xFFFFFFFF/0x00000000/1]
4-705-014	Calibration Result5	Result5-14	ENG	[0x00000000 to 0xFFFFFFFF/0x00000000/1]
4-705-015	Calibration Result5	Result5-15	ENG	[0x00000000 to 0xFFFFFFFF/0x00000000/1]
4-705-016	Calibration Result5	Result5-16	ENG	[0x00000000 to 0xFFFFFFFF/0x00000000/1]
4-706-001	Calibration Result6	Result6-1	ENG	[0x00000000 to 0xFFFFFFFF/0x00000000/1]
4-706-002	Calibration Result6	Result6-2	ENG	[0x00000000 to 0xFFFFFFFF/0x00000000/1]
4-706-003	Calibration Result6	Result6-3	ENG	[0x00000000 to 0xFFFFFFFF/0x00000000/1]
4-706-004	Calibration Result6	Result6-4	ENG	[0x00000000 to 0xFFFFFFFF/0x00000000/1]
4-706-005	Calibration Result6	Result6-5	ENG	[0x00000000 to 0xFFFFFFFF/0x00000000/1]
4-706-006	Calibration Result6	Result6-6	ENG	[0x00000000 to 0xFFFFFFFF/0x00000000/1]
4-707-001	Calibration Result7	Result7-1	ENG	[0x00000000 to 0xFFFFFFFF/0x00000000/1]
4-707-002	Calibration Result7	Result7-2	ENG	[0x00000000 to 0xFFFFFFFF/0x00000000/1]
4-707-003	Calibration Result7	Result7-3	ENG	[0x00000000 to 0xFFFFFFFF/0x00000000/1]
4-707-004	Calibration Result7	Result7-4	ENG	[0x00000000 to 0xFFFFFFFF/0x00000000/1]
4-707-005	Calibration Result7	Result7-5	ENG	[0x00000000 to 0xFFFFFFFF/0x00000000/1]
4-707-006	Calibration Result7	Result7-6	ENG	[0x00000000 to 0xFFFFFFFF/0x00000000/1]
4-707-007	Calibration Result7	Result7-7	ENG	[0x00000000 to 0xFFFFFFFF/0x00000000/1]
4-707-008	Calibration Result7	Result7-8	ENG	[0x00000000 to 0xFFFFFFFF/0x00000000/1]
4-707-	Calibration	Result7-9	ENG	[0x00000000 to

### 3.SP Mode Tables

SP No.	Large Category	Small Category	ENG or CTL	[Min to Max/Init./Step]
009	Result7			0xFFFFFFFF/0x00000000/1]
4-707-010	Calibration Result7	Result7-10	ENG	[0x00000000 to 0xFFFFFFFF/0x00000000/1]
4-707-011	Calibration Result7	Result7-11	ENG	[0x00000000 to 0xFFFFFFFF/0x00000000/1]
4-707-012	Calibration Result7	Result7-12	ENG	[0x00000000 to 0xFFFFFFFF/0x00000000/1]
4-707-013	Calibration Result7	Result7-13	ENG	[0x00000000 to 0xFFFFFFFF/0x00000000/1]
4-707-014	Calibration Result7	Result7-14	ENG	[0x00000000 to 0xFFFFFFFF/0x00000000/1]
4-708-001	Calibration Result8	Result8-1	ENG	[0x00000000 to 0xFFFFFFFF/0x00000000/1]
4-708-002	Calibration Result8	Result8-2	ENG	[0x00000000 to 0xFFFFFFFF/0x00000000/1]
4-708-003	Calibration Result8	Result8-3	ENG	[0x00000000 to 0xFFFFFFFF/0x00000000/1]
4-708-004	Calibration Result8	Result8-4	ENG	[0x00000000 to 0xFFFFFFFF/0x00000000/1]
4-708-005	Calibration Result8	Result8-5	ENG	[0x00000000 to 0xFFFFFFFF/0x00000000/1]
4-708-006	Calibration Result8	Result8-6	ENG	[0x00000000 to 0xFFFFFFFF/0x00000000/1]
4-708-007	Calibration Result8	Result8-7	ENG	[0x00000000 to 0xFFFFFFFF/0x00000000/1]
4-708-008	Calibration Result8	Result8-8	ENG	[0x00000000 to 0xFFFFFFFF/0x00000000/1]
4-708-009	Calibration Result8	Result8-9	ENG	[0x00000000 to 0xFFFFFFFF/0x00000000/1]
4-708-010	Calibration Result8	Result8-10	ENG	[0x00000000 to 0xFFFFFFFF/0x00000000/1]
4-708-011	Calibration Result8	Result8-11	ENG	[0x00000000 to 0xFFFFFFFF/0x00000000/1]
4-708-012	Calibration Result8	Result8-12	ENG	[0x00000000 to 0xFFFFFFFF/0x00000000/1]
4-708-	Calibration	Result8-13	ENG	[0x00000000 to

SP No.	Large Category	Small Category	ENG or CTL	[Min to Max/Init./Step]
013	Result8			0xFFFFFFFF/0x00000000/1]
4-708-014	Calibration Result8	Result8-14	ENG	[0x00000000 to 0xFFFFFFFF/0x00000000/1]
4-708-015	Calibration Result8	Result8-15	ENG	[0x00000000 to 0xFFFFFFFF/0x00000000/1]
4-708-016	Calibration Result8	Result8-16	ENG	[0x00000000 to 0xFFFFFFFF/0x00000000/1]

## Main SP Tables-5 (Engine)

### SP5-XXX (Mode)

SP No.	Large Category	Small Category	ENG or CTL	[Min to Max/Init./Step]
5-186-001	RK4: Setting		ENG*	[0 to 1/0/1]
5-801-002	Memory Clear	Engine	ENG	[0 to 1/0/1]
5-802-001	All Data Initialize	Result	ENG	[0 to 1/0/1]
5-803-001	INPUT Check	Exit Full Sensor	ENG	[0 to 1/0/1]
5-803-002	INPUT Check	Du On Sensor	ENG	[0 to 1/0/1]
5-803-003	INPUT Check	Fuser Exit On Sensor	ENG	[0 to 1/0/1]
5-803-004	INPUT Check	Regist Sens On Sensor	ENG	[0 to 1/0/1]
5-803-005	INPUT Check	MPF Jam On Sensor	ENG	[0 to 1/0/1]
5-803-010	INPUT Check		ENG	[0 to 255/0/1]
5-803-011	INPUT Check		ENG	[0 to 255/0/1]
5-803-012	INPUT Check		ENG	[0 to 255/0/1]
5-803-013	INPUT Check		ENG	[0 to 255/0/1]
5-803-014	INPUT Check		ENG	[0 to 255/0/1]
5-803-018	INPUT Check	IPU Version	ENG	[0 to 7/0/1]
5-803-104	INPUT Check	SDCU Set	ENG	[0 to 1/0/1]
5-804-001	OUTPUT Check	CTLFAN Motor	ENG	[0 to 1/0/1]
5-804-101	OUTPUT Check	FAN:LSU	ENG	[0 to 1/0/1]
5-804-102	OUTPUT Check	FAN:BELT	ENG	[0 to 1/0/1]
5-804-103	OUTPUT Check	FAN:ALL	ENG	[0 to 1/0/1]
5-804-202	OUTPUT Check	Scanner Lamp	ENG	[0 to 1/0/1]
5-805-002	OUTPUT CHECK		ENG	[0 to 1/0/1]
5-805-003	OUTPUT CHECK	Eraser Disconnect	ENG	[0 to 1/0/1]
5-805-004	OUTPUT CHECK	Dev Recovery	ENG	[0 to 1/0/1]
5-805-005	OUTPUT CHECK	Calib R	ENG	[0 to 1/0/1]
5-805-006	OUTPUT CHECK	LSU Clean Direc	ENG	[0 to 1/0/1]
5-805-007	OUTPUT CHECK	LSU Clean Time	ENG	[0 to 255/0/1]
5-805-008	OUTPUT CHECK	LSU Clean	ENG	[0 to 1/0/1]
5-805-009	OUTPUT CHECK	TonerMotorDrive	ENG	[0 to 1/0/1]
5-805-010	OUTPUT CHECK	TrayPaperQuan	ENG	[0 to 1/0/1]
5-805-011	OUTPUT CHECK	TrayPaperQuanSts	ENG	[0 to 1/0/1]
5-805-012	OUTPUT CHECK	Dev Recovery R	ENG	[0 to 1/0/1]
5-805-013	OUTPUT CHECK	Registration	ENG	[0 to 1/0/1]
5-805-014	OUTPUT CHECK	Registration R	ENG	[0 to 1/0/1]
5-810-001	SC Reset	Fusing SC Reset	ENG	[0 to 1/0/1]

## 3.SP Mode Tables

SP No.	Large Category	Small Category	ENG or CTL	[Min to Max/Init./Step]
5-811-002	Machine Serial	Display	ENG*	[0 to 255/0/1]
5-894-001	ExternalCountSet	SW Charge Mode	ENG*	[0 to 2/0/1]
5-900-001	Engine Log Upload	Pattern	ENG*	[0 to 4/0/1]
5-900-002	Engine Log Upload	Trigger	ENG*	[0 to 3/0/1]
5-901-005	All Data Initialize	China	ENG	[0 to 1/0/1]
5-901-006	All Data Initialize	EU(230V)	ENG	[0 to 1/0/1]
5-901-007	All Data Initialize	NA(120V)	ENG	[0 to 1/0/1]
5-901-008	All Data Initialize	Asia	ENG	[0 to 1/0/1]
5-901-009	All Data Initialize	Oceania	ENG	[0 to 1/0/1]
5-930-001	Meter Charge	Setting	ENG*	[0 to 1/1/1]
5-931-001	Life Alert Disp.	Maintenance Kit	ENG*	[0 to 1/0/1]

**Main SP Tables-5 (Controller)**

## SP5-XXX (Mode)

SP No.	Large Category	Small Category	ENG or CTL	[Min to Max/Init./Step]
5-001-001	All Indicators On		CTL	[0 to 0/0/0]
5-024-001	mm/inch Selection	0:mm 1:inch	CTL*	NA: [0 to 1/1/1] EU/AP: [0 to 1/0/1]
5-045-001	Accounting counter	Counter Method	CTL*	[0 to 7/0/1]
5-051-001	Refill Toner Disp		CTL*	[0 to 1/0/1]
5-055-001	DisplayIPaddress		CTL*	[0 to 1/0/1]
5-083-001	LED Light Switch		CTL*	[0 to 1/0/1]
5-083-002	LED Light Switch		CTL*	[0 to 1/0/1]
5-150-001	Length Setting	Bypass(0:OFF 1:Long)	CTL	[0 to 1/0/1]
5-169-001	CE Login		CTL*	[0 to 1/0/1]
5-191-001	Power Setting	Power Str	CTL*	[0 to 1/1/1]
5-302-	Set Time	Time Difference	CTL*	NA: [-1440 to 1440/-300/1]

## 3.SP Mode Tables

SP No.	Large Category	Small Category	ENG or CTL	[Min to Max/Init./Step]
002				EU: [-1440 to 1440/60/1] AP: [-1440 to 1440/480/1]
5-305-101	Auto Off Set	Auto Off Limit Set	CTL*	[0 to 1/0/1]
5-307-001	Daylight Saving Time	ON/OFF	CTL*	NA/EU: [0 to 1/1/1] AP: [0 to 1/0/1]
5-307-003	Daylight Saving Time	Start	CTL*	NA: [0 to 0xffffffff/0x03200210/1] EU: [0 to 0xffffffff/0x03500010/1] AP: [0 to 0xffffffff/0x10500010/1]
5-307-004	Daylight Saving Time	End	CTL*	NA: [0 to 0xffffffff/0x11100200/1] EU: [0 to 0xffffffff/0x10500100/1] AP: [0 to 0xffffffff/0x03100000/1]
5-401-104	Access Control	Authentication Time	CTL*	[0 to 255/0/1sec]
5-401-162	Access Control	Extend Certification Detail	CTL*	[0 to 0xff/0/1]
5-401-200	Access Control	SDK1 UniqueID	CTL*	[0 to 0xFFFFFFFF/0/1]
5-401-201	Access Control	SDK1 Certification Method	CTL*	[0 to 0xFF/0/1]
5-401-	Access Control	SDK2 UniqueID	CTL*	[0 to 0xFFFFFFFF/0/1]

### 3.SP Mode Tables

SP No.	Large Category	Small Category	ENG or CTL	[Min to Max/Init./Step]
210				
5-401-211	Access Control	SDK2 Certification Method	CTL*	[0 to 0xFF/0/1]
5-401-220	Access Control	SDK3 UniqueID	CTL*	[0 to 0xFFFFFFFF/0/1]
5-401-221	Access Control	SDK3 Certification Method	CTL*	[0 to 0xFF/0/1]
5-401-230	Access Control	SDK Cert	CTL*	[0 to 0xff/0/1]
5-401-240	Access Control	Detail Option	CTL*	[0 to 0xff/0/1]
5-402-101	Access Control	SDKJ1 Limit Setting	CTL*	[0 to 0xFF/0/1]
5-402-102	Access Control	SDKJ2 Limit Setting	CTL*	[0 to 0xFF/0/1]
5-402-103	Access Control	SDKJ3 Limit Setting	CTL*	[0 to 0xFF/0/1]
5-402-104	Access Control	SDKJ4 Limit Setting	CTL*	[0 to 0xFF/0/1]
5-402-105	Access Control	SDKJ5 Limit Setting	CTL*	[0 to 0xFF/0/1]
5-402-106	Access Control	SDKJ6 Limit Setting	CTL*	[0 to 0xFF/0/1]
5-	Access Control	SDKJ7 Limit Setting	CTL*	[0 to 0xFF/0/1]

## 3.SP Mode Tables

SP No.	Large Category	Small Category	ENG or CTL	[Min to Max/Init./Step]
402-107				
5-402-108	Access Control	SDKJ8 Limit Setting	CTL*	[0 to 0xFF/0/1]
5-402-109	Access Control	SDKJ9 Limit Setting	CTL*	[0 to 0xFF/0/1]
5-402-110	Access Control	SDKJ10 Limit Setting	CTL*	[0 to 0xFF/0/1]
5-402-111	Access Control	SDKJ11 Limit Setting	CTL*	[0 to 0xFF/0/1]
5-402-112	Access Control	SDKJ12 Limit Setting	CTL*	[0 to 0xFF/0/1]
5-402-113	Access Control	SDKJ13 Limit Setting	CTL*	[0 to 0xFF/0/1]
5-402-114	Access Control	SDKJ14 Limit Setting	CTL*	[0 to 0xFF/0/1]
5-402-115	Access Control	SDKJ15 Limit Setting	CTL*	[0 to 0xFF/0/1]
5-402-116	Access Control	SDKJ16 Limit Setting	CTL*	[0 to 0xFF/0/1]
5-402-117	Access Control	SDKJ17 Limit Setting	CTL*	[0 to 0xFF/0/1]
5-402-118	Access Control	SDKJ18 Limit Setting	CTL*	[0 to 0xFF/0/1]

### 3.SP Mode Tables

SP No.	Large Category	Small Category	ENG or CTL	[Min to Max/Init./Step]
5-402-119	Access Control	SDKJ19 Limit Setting	CTL*	[0 to 0xFF/0/1]
5-402-120	Access Control	SDKJ20 Limit Setting	CTL*	[0 to 0xFF/0/1]
5-402-121	Access Control	SDKJ21 Limit Setting	CTL*	[0 to 0xFF/0/1]
5-402-122	Access Control	SDKJ22 Limit Setting	CTL*	[0 to 0xFF/0/1]
5-402-123	Access Control	SDKJ23 Limit Setting	CTL*	[0 to 0xFF/0/1]
5-402-124	Access Control	SDKJ24 Limit Setting	CTL*	[0 to 0xFF/0/1]
5-402-125	Access Control	SDKJ25 Limit Setting	CTL*	[0 to 0xFF/0/1]
5-402-126	Access Control	SDKJ26 Limit Setting	CTL*	[0 to 0xFF/0/1]
5-402-127	Access Control	SDKJ27 Limit Setting	CTL*	[0 to 0xFF/0/1]
5-402-128	Access Control	SDKJ28 Limit Setting	CTL*	[0 to 0xFF/0/1]
5-402-129	Access Control	SDKJ29 Limit Setting	CTL*	[0 to 0xFF/0/1]
5-402-130	Access Control	SDKJ30 Limit Setting	CTL*	[0 to 0xFF/0/1]

## 3.SP Mode Tables

SP No.	Large Category	Small Category	ENG or CTL	[Min to Max/Init./Step]
5-402-141	Access Control	SDKJ1 ProductID	CTL*	[0 to 0xffffffff/0/1]
5-402-142	Access Control	SDKJ2 ProductID	CTL*	[0 to 0xffffffff/0/1]
5-402-143	Access Control	SDKJ3 ProductID	CTL*	[0 to 0xffffffff/0/1]
5-402-144	Access Control	SDKJ4 ProductID	CTL*	[0 to 0xffffffff/0/1]
5-402-145	Access Control	SDKJ5 ProductID	CTL*	[0 to 0xffffffff/0/1]
5-402-146	Access Control	SDKJ6 ProductID	CTL*	[0 to 0xffffffff/0/1]
5-402-147	Access Control	SDKJ7 ProductID	CTL*	[0 to 0xffffffff/0/1]
5-402-148	Access Control	SDKJ8 ProductID	CTL*	[0 to 0xffffffff/0/1]
5-402-149	Access Control	SDKJ9 ProductID	CTL*	[0 to 0xffffffff/0/1]
5-402-150	Access Control	SDKJ10 ProductID	CTL*	[0 to 0xffffffff/0/1]
5-402-151	Access Control	SDKJ11 ProductID	CTL*	[0 to 0xffffffff/0/1]
5-402-152	Access Control	SDKJ12 ProductID	CTL*	[0 to 0xffffffff/0/1]

### 3.SP Mode Tables

SP No.	Large Category	Small Category	ENG or CTL	[Min to Max/Init./Step]
5-402-153	Access Control	SDKJ13 ProductID	CTL*	[0 to 0xffffffff/0/1]
5-402-154	Access Control	SDKJ14 ProductID	CTL*	[0 to 0xffffffff/0/1]
5-402-155	Access Control	SDKJ15 ProductID	CTL*	[0 to 0xffffffff/0/1]
5-402-156	Access Control	SDKJ16 ProductID	CTL*	[0 to 0xffffffff/0/1]
5-402-157	Access Control	SDKJ17 ProductID	CTL*	[0 to 0xffffffff/0/1]
5-402-158	Access Control	SDKJ18 ProductID	CTL*	[0 to 0xffffffff/0/1]
5-402-159	Access Control	SDKJ19 ProductID	CTL*	[0 to 0xffffffff/0/1]
5-402-160	Access Control	SDKJ20 ProductID	CTL*	[0 to 0xffffffff/0/1]
5-402-161	Access Control	SDKJ21 ProductID	CTL*	[0 to 0xffffffff/0/1]
5-402-162	Access Control	SDKJ22 ProductID	CTL*	[0 to 0xffffffff/0/1]
5-402-163	Access Control	SDKJ23 ProductID	CTL*	[0 to 0xffffffff/0/1]
5-402-164	Access Control	SDKJ24 ProductID	CTL*	[0 to 0xffffffff/0/1]

SP No.	Large Category	Small Category	ENG or CTL	[Min to Max/Init./Step]
5-402-165	Access Control	SDKJ25 ProductID	CTL*	[0 to 0xffffffff/0/1]
5-402-166	Access Control	SDKJ26 ProductID	CTL*	[0 to 0xffffffff/0/1]
5-402-167	Access Control	SDKJ27 ProductID	CTL*	[0 to 0xffffffff/0/1]
5-402-168	Access Control	SDKJ28 ProductID	CTL*	[0 to 0xffffffff/0/1]
5-402-169	Access Control	SDKJ29 ProductID	CTL*	[0 to 0xffffffff/0/1]
5-402-170	Access Control	SDKJ30 ProductID	CTL*	[0 to 0xffffffff/0/1]
5-404-001	User Code Clear	UsrCodeCtrClr	CTL	[0 to 0/0/0]
5-411-004	LDAP-Certification	Simplified Authentication	CTL*	[0 to 1/1/1]
5-411-005	LDAP-Certification	Password Null Not Permit	CTL*	[0 to 1/1/1]
5-411-006	LDAP-Certification	Detail Option	CTL*	[0 to 0xff/0/1]
5-412-100	Krb-Certification	Encrypt Mode	CTL*	[0 to 0xFF/0x1F/1]
5-413-001	Lockout Setting	Lockout On/Off	CTL*	[0 to 1/0/1]

### 3.SP Mode Tables

SP No.	Large Category	Small Category	ENG or CTL	[Min to Max/Init./Step]
5-413-002	Lockout Setting	Lockout Threshold	CTL*	[1 to 10/5/1]
5-413-003	Lockout Setting	Cancel On/Off	CTL*	[0 to 1/0/1]
5-413-004	Lockout Setting	Cancel Time	CTL*	[1 to 9999/60/1min]
5-414-001	Access Mitigation	Mitigation On/Off	CTL*	[0 to 1/0/1]
5-414-002	Access Mitigation	Mitigation Time	CTL*	[0 to 60/15/1min]
5-415-001	Password Attack	Permission Number	CTL*	[0 to 100/30/1]
5-415-002	Password Attack	Detect Time	CTL*	[1 to 10/5/1]
5-416-001	Access Info	User Max Num	CTL*	[50 to 200/200/1]
5-416-002	Access Info	Password Max Num	CTL*	[50 to 200/200/1]
5-416-003	Access Info	Monitor Interval	CTL*	[1 to 10/3/1]
5-417-001	Access Attack	Permission Num	CTL*	[0 to 500/100/1]
5-417-002	Access Attack	Attack DetectTime	CTL*	[10 to 30/10/1sec]

## 3.SP Mode Tables

SP No.	Large Category	Small Category	ENG or CTL	[Min to Max/Init./Step]
5-417-003	Access Attack	Cert Waite	CTL*	[0 to 9/3/1sec]
5-417-004	Access Attack	Attack Max Num	CTL*	[50 to 200/200/1]
5-420-041	User Auth	Printer	CTL*	[0 to 1/0/1]
5-420-051	User Auth	SDK1	CTL*	[0 to 1/0/1]
5-420-061	User Auth	SDK2	CTL*	[0 to 1/0/1]
5-420-071	User Auth	SDK3	CTL*	[0 to 1/0/1]
5-481-001	Auth. Error Code	System Log Disp	CTL*	[0 to 1/0/1]
5-501-001	PM Alarm Interval	Printout	CTL*	[0 to 9999/0/1]
5-504-001	Jam Alarm		CTL*	[0 to 3/3/1]
5-504-002	Jam Alarm	Threshold	CTL*	[1 to 99/10/1]
5-505-001	Error Alarm		CTL*	[0 to 255/15/1]
5-505-002	Error Alarm	Threshold	CTL*	[1 to 99/5/1]

### 3.SP Mode Tables

SP No.	Large Category	Small Category	ENG or CTL	[Min to Max/Init./Step]
5-507-001	Supply/CC Alarm	Paper Size	CTL*	[0 to 1/0/1]
5-507-003	Supply/CC Alarm	Toner	CTL*	[0 to 1/1/1]
5-507-080	Supply/CC Alarm	Toner Call Timing	CTL*	[0 to 1/0/1]
5-507-081	Supply/CC Alarm	Toner Call Thresh	CTL*	[10 to 90/10/10%]
5-507-128	Supply/CC Alarm	Interval: Others	CTL*	[250 to 10000/1000/1]
5-507-133	Supply/CC Alarm	Interval: A4	CTL*	[250 to 10000/1000/1]
5-507-134	Supply/CC Alarm	Interval: A5	CTL*	[250 to 10000/1000/1]
5-507-142	Supply/CC Alarm	Interval: B5	CTL*	[250 to 10000/1000/1]
5-507-164	Supply/CC Alarm	Interval: LG	CTL*	[250 to 10000/1000/1]
5-507-166	Supply/CC Alarm	Interval: LT	CTL*	[250 to 10000/1000/1]
5-507-172	Supply/CC Alarm	Interval: HLT	CTL*	[250 to 10000/1000/1]
5-515-001	SC/Alarm Setting	SC Call	CTL*	[0 to 1/1/1]

## 3.SP Mode Tables

SP No.	Large Category	Small Category	ENG or CTL	[Min to Max/Init./Step]
5-515-002	SC/Alarm Setting	Service Parts Near End Call	CTL*	[0 to 1/0/1]
5-515-003	SC/Alarm Setting	Service Parts End Call	CTL*	[0 to 1/0/1]
5-515-004	SC/Alarm Setting	User Call	CTL*	[0 to 1/1/1]
5-515-006	SC/Alarm Setting	Communication Test Call	CTL*	[0 to 1/1/1]
5-515-007	SC/Alarm Setting	Machine Information Notice	CTL*	[0 to 1/1/1]
5-515-008	SC/Alarm Setting	Alarm Notice	CTL*	[0 to 1/0/1]
5-515-009	SC/Alarm Setting	Non Genuine Tonner Ararm	CTL*	[0 to 1/1/1]
5-515-010	SC/Alarm Setting	Supply Automatic Ordering Call	CTL*	[0 to 1/1/1]
5-515-011	SC/Alarm Setting	Supply Management Report Call	CTL*	[0 to 1/1/1]
5-515-012	SC/Alarm Setting	Jam/Door Open Call	CTL*	[0 to 1/0/1]
5-515-050	SC/Alarm Setting	Timeout:Manual Call	CTL*	[1 to 255/5/1min]
5-515-051	SC/Alarm Setting	Timeout:Other Call	CTL*	[1 to 255/10/1min]

### 3.SP Mode Tables

SP No.	Large Category	Small Category	ENG or CTL	[Min to Max/Init./Step]
5-517-061	Get Machine Info	AD exec setting	CTL	[0 to 1/0/1]
5-517-062	Get Machine Info	AD exec interval	CTL	[0 to 1/0/1]
5-517-063	Get Machine Info	AD exec weekday	CTL	[0 to 6/0/1]
5-517-064	Get Machine Info	AD exec hour	CTL	[0 to 23/0/1]
5-517-065	Get Machine Info	AD exec min	CTL	[0 to 59/0/1]
5-517-066	Get Machine Info	AD SNMP Community	CTL	[0 to 0/0/0]
5-728-001	Network Setting	NAT Machine Port1	CTL*	[1 to 65535/49101/1]
5-728-002	Network Setting	NAT UI Port1	CTL*	[1 to 65535/55101/1]
5-728-003	Network Setting	NAT Machine Port2	CTL*	[1 to 65535/49102/1]
5-728-004	Network Setting	NAT UI Port2	CTL*	[1 to 65535/55102/1]
5-728-005	Network Setting	NAT Machine Port3	CTL*	[1 to 65535/49103/1]
5-728-006	Network Setting	NAT UI Port3	CTL*	[1 to 65535/55103/1]

## 3.SP Mode Tables

SP No.	Large Category	Small Category	ENG or CTL	[Min to Max/Init./Step]
5-728-007	Network Setting	NAT Machine Port4	CTL*	[1 to 65535/49104/1]
5-728-008	Network Setting	NAT UI Port4	CTL*	[1 to 65535/55104/1]
5-728-009	Network Setting	NAT Machine Port5	CTL*	[1 to 65535/49105/1]
5-728-010	Network Setting	NAT UI Port5	CTL*	[1 to 65535/55105/1]
5-728-011	Network Setting	NAT Machine Port6	CTL*	[1 to 65535/49106/1]
5-728-012	Network Setting	NAT UI Port6	CTL*	[1 to 65535/55106/1]
5-728-013	Network Setting	NAT Machine Port7	CTL*	[1 to 65535/49107/1]
5-728-014	Network Setting	NAT UI Port7	CTL*	[1 to 65535/55107/1]
5-728-015	Network Setting	NAT Machine Port8	CTL*	[1 to 65535/49108/1]
5-728-016	Network Setting	NAT UI Port8	CTL*	[1 to 65535/55108/1]
5-728-017	Network Setting	NAT Machine Port9	CTL*	[1 to 65535/49109/1]
5-728-018	Network Setting	NAT UI Port9	CTL*	[1 to 65535/55109/1]

### 3.SP Mode Tables

SP No.	Large Category	Small Category	ENG or CTL	[Min to Max/Init./Step]
5-728-019	Network Setting	NAT Machine Port10	CTL*	[1 to 65535/49110/1]
5-728-020	Network Setting	NAT UI Port10	CTL*	[1 to 65535/55110/1]
5-728-101	Network Setting	PacketCapture	CTL	[0 to 1/0/1]
5-728-102	Network Setting	PacketCapture:mode	CTL	[0 to 1/0/1]
5-728-103	Network Setting	PacketCapture:interface	CTL	[0 to 3/0/1]
5-728-104	Network Setting	PacketCapture:length	CTL	[54 to 65535/128/1]
5-728-105	Network Setting	PacketCapture:broadcast	CTL	[0 to 1/0/1]
5-728-106	Network Setting	PacketCapture:specify port	CTL	[0 to 1/0/1]
5-728-107	Network Setting	PacketCapture:portnumber	CTL	[0 to 65535/0/1]
5-728-108	Network Setting	PacketCapture:time	CTL	[0 to 0xffffffff/0/1]
5-731-001	Counter Effect	Mk1 Paper>Combine	CTL*	[0 to 1/0/1]
5-745-211	DeemedPowerConsumption	Controller Standby	CTL*	[0 to 9999/0/1]

## 3.SP Mode Tables

SP No.	Large Category	Small Category	ENG or CTL	[Min to Max/Init./Step]
5-745-212	DeemedPowerConsumption	STR	CTL*	[0 to 9999/0/1]
5-745-213	DeemedPowerConsumption	Main Power Off	CTL*	[0 to 9999/0/1]
5-745-214	DeemedPowerConsumption	Scanning and Printing	CTL*	[0 to 9999/0/1]
5-745-215	DeemedPowerConsumption	Printing	CTL*	[0 to 9999/0/1]
5-745-216	DeemedPowerConsumption	Scanning	CTL*	[0 to 9999/0/1]
5-745-217	DeemedPowerConsumption	Engine Standby	CTL*	[0 to 9999/0/1]
5-745-218	DeemedPowerConsumption	Low Power Consumption	CTL*	[0 to 9999/0/1]
5-745-219	DeemedPowerConsumption	Silent condition	CTL*	[0 to 9999/0/1]
5-745-220	DeemedPowerConsumption	Heater Off	CTL*	[0 to 9999/0/1]
5-749-001	Import/Export	Export	CTL	[0 to 0/0/0]
5-749-101	Import/Export	Import	CTL	[0 to 0/0/0]
5-764-001	NFC	GuestNW	CTL*	[0 to 1/0/1]

### 3.SP Mode Tables

SP No.	Large Category	Small Category	ENG or CTL	[Min to Max/Init./Step]
5-764-002	NFC	EncryptCom	CTL*	[0 to 1/0/1]
5-764-003	NFC	Port1	CTL*	[0 to 65535/8081/1]
5-764-004	NFC	Port2	CTL*	[0 to 65535/8080/1]
5-764-005	NFC	Port3	CTL*	[0 to 65535/80/1]
5-801-001	Memory Clear	All Clear	CTL	[0 to 0/0/0]
5-801-003	Memory Clear	SCS	CTL	[0 to 0/0/0]
5-801-004	Memory Clear	IMH	CTL	[0 to 0/0/0]
5-801-005	Memory Clear	MCS	CTL	[0 to 0/0/0]
5-801-008	Memory Clear	Printer	CTL	[0 to 0/0/0]
5-801-010	Memory Clear	GWWS	CTL	[0 to 0/0/0]
5-801-011	Memory Clear	NCS	CTL	[0 to 0/0/0]
5-801-014	Memory Clear	Clear DCS Setting	CTL	[0 to 0/0/0]

## 3.SP Mode Tables

SP No.	Large Category	Small Category	ENG or CTL	[Min to Max/Init./Step]
5-801-015	Memory Clear	Clr UCS Setting	CTL	[0 to 0/0/0]
5-801-016	Memory Clear	Clear DCS Setting	CTL	[0 to 0/0/0]
5-801-017	Memory Clear	CCS	CTL	[0 to 0/0/0]
5-801-018	Memory Clear	SRM Memory Clr	CTL	[0 to 0/0/0]
5-801-019	Memory Clear	LCS	CTL	[0 to 0/0/0]
5-801-021	Memory Clear	ECS	CTL	[0 to 0/0/0]
5-801-025	Clea Memory	websys	CTL	[0 to 0/0/0]
5-801-027	Memory Clear	SAS	CTL	[0 to 0/0/0]
5-801-028	Memory Clear	RWS	CTL	[0 to 0/0/0]
5-812-001	Service TEL	Telephone	CTL*	[0 to 0/0/0]
5-812-002	Service TEL	Facsimile	CTL*	[0 to 0/0/0]
5-816-001	NRS Function	I/F Setting	CTL*	[0 to 2/2/1]

### 3.SP Mode Tables

SP No.	Large Category	Small Category	ENG or CTL	[Min to Max/Init./Step]
5-816-002	NRS Function	CE Call	CTL*	[0 to 1/0/1]
5-816-003	NRS Function	Function Flag	CTL*	[0 to 1/0/1]
5-816-007	NRS Function	SSL Disable	CTL*	[0 to 1/0/1]
5-816-008	NRS Function	RCG Connect T/O	CTL*	[1 to 90/30/1sec]
5-816-009	NRS Function	RCG Write Timeout	CTL*	[0 to 100/60/1sec]
5-816-010	NRS Function	RCG Read Timeout	CTL*	[0 to 100/60/1sec]
5-816-011	NRS Function	Port 80	CTL*	[0 to 1/0/1]
5-816-013	Remote Service	RFU Timing	CTL*	[0 to 1/1/1]
5-816-014	Remote Service	RCG Error Cause	CTL	[0 to 2/0/1]
5-816-063	Remote Service	HTTP Proxy Host	CTL*	[0 to 0/0/0]
5-816-064	Remote Service	HTTP Proxy Port	CTL*	[0 to 0xffff/0/1]
5-816-065	Remote Service	HTTP Prox AutUsr	CTL*	[0 to 0/0/0]

## 3.SP Mode Tables

SP No.	Large Category	Small Category	ENG or CTL	[Min to Max/Init./Step]
5-816-066	Remote Service	HTTP Prox AutPass	CTL*	[0 to 0/0/0]
5-816-102	Remote Service	CERT:Encrypt Lv	CTL*	[1 to 2/1/1]
5-816-103	Remote Service	ClientCommMethod	CTL*	[0 to 3/0/1]
5-816-104	Remote Service	Client Comm Limit	CTL*	[1 to 7/7/1]
5-816-115	Remote Service	NetInfoWaitTimer	CTL*	[5 to 255/5/1sec]
5-816-190	Remote Service	3G DongleID	CTL*	[0 to 0/0/0]
5-816-209	Remote Service	Instl Clear	CTL	[0 to 1/0/1]
5-821-002	RCG Setting	RCG IPv4Addr	CTL*	[0 to 0xffffffff/0/1]
5-821-003	RCG Setting	RCG Port	CTL*	[0 to 65535/443/1]
5-821-004	RCG Setting	RCG IPv4URLPath	CTL*	[0 to 0/0/0]
5-821-005	RCG Setting	RCG IPv6Addr	CTL*	[0 to 0/0/0]
5-821-006	RCG Setting	RCG IPv6URLPath	CTL*	[0 to 0/0/0]

### 3.SP Mode Tables

SP No.	Large Category	Small Category	ENG or CTL	[Min to Max/Init./Step]
5-821-007	RCG Setting	RCG HostName	CTL*	[0 to 0/0/0]
5-821-008	RCG Setting	RCG HostURLPath	CTL*	[0 to 0/0/0]
5-824-001	NVRAM Upload		CTL	[0 to 0/0/0]
5-825-001	NVRAM Download		CTL	[0 to 0/0/0]
5-828-039	Network Setting	User Class	CTL*	[0 to 0/0/0]
5-828-040	Network Setting	Class Id	CTL*	[0 to 0/0/0]
5-828-050	Network Setting	1284 Compatibility (Centro)	CTL*	[0 to 1/1/1]
5-828-052	Network Setting	ECP (Centro)	CTL*	[0 to 1/1/1]
5-828-065	Network Setting	Job Spooling	CTL*	[0 to 1/0/1]
5-828-066	Network Setting	Job Spooling Clear: Start Time	CTL*	[0 to 1/1/1]
5-828-069	Network Setting	Job Spooling (Protocol)	CTL*	[0x00 to 0xff/0x7f/0]
5-828-087	Network Setting	Protocol usage	CTL*	[0x00000000 to 0xffffffff/0x00000000/1]

## 3.SP Mode Tables

SP No.	Large Category	Small Category	ENG or CTL	[Min to Max/Init./Step]
5-828-090	Network Setting	TELNET(0:OFF 1:ON)	CTL*	[0 to 1/1/1]
5-828-091	Network Setting	Web(0:OFF 1:ON)	CTL*	[0 to 1/1/1]
5-828-145	Network Setting	Active IPv6 Link Local Address	CTL	[0 to 0/0/0]
5-828-147	Network Setting	Active IPv6 Stateless Address 1	CTL	[0 to 0/0/0]
5-828-149	Network Setting	Active IPv6 Stateless Address 2	CTL	[0 to 0/0/0]
5-828-151	Network Setting	Active IPv6 Stateless Address 3	CTL	[0 to 0/0/0]
5-828-153	Network Setting	Active IPv6 Stateless Address 4	CTL	[0 to 0/0/0]
5-828-155	Network Setting	Active IPv6 Stateless Address 5	CTL	[0 to 0/0/0]
5-828-156	Network Setting	IPv6 Manual Address	CTL*	[0 to 0/0/0]
5-828-158	Network Setting	IPv6 Gateway Address	CTL*	[0 to 0/0/0]
5-828-161	Network Setting	IPv6 Stateless Auto Setting	CTL*	[0 to 1/1/1]
5-828-219	Network Setting	IPsec Aggressive Mode Setting	CTL*	[0 to 1/0/1]

### 3.SP Mode Tables

SP No.	Large Category	Small Category	ENG or CTL	[Min to Max/Init./Step]
5-828-236	Network Setting	Web Item visible	CTL*	[0x0000 to 0xffff/0xffff/1]
5-828-237	Network Setting	Web shop Link	CTL*	[0 to 1/1/1]
5-828-238	Network Setting	Web Supplies Link visible	CTL*	[0 to 1/1/1]
5-828-239	Network Setting	Web Link1 Name	CTL*	[0 to 0/0/0]
5-828-240	Network Setting	Web Link1 URL	CTL*	[0 to 0/0/0]
5-828-241	Network Setting	Web Link1 visible	CTL*	[0 to 1/1/1]
5-828-242	Network Setting	Web Link2 Name	CTL*	[0 to 0/0/0]
5-828-243	Network Setting	Web Link2 URL	CTL*	[0 to 0/0/0]
5-828-244	Network Setting	Web Link2 visible	CTL*	[0 to 1/1/1]
5-828-249	Network Setting	DHCPv6 DUID	CTL	[0 to 0/0/0]
5-832-001	HDD	Formatting(ALL)	CTL	[0 to 0/0/0]
5-840-006	IEEE 802.11	Channel MAX	CTL*	[1 to 14/14/1]

## 3.SP Mode Tables

SP No.	Large Category	Small Category	ENG or CTL	[Min to Max/Init./Step]
5-840-007	IEEE 802.11	Channel MIN	CTL*	[1 to 14/1/1]
5-840-011	IEEE 802.11	WEP Key Select	CTL*	[0x00 to 0x11/0x00/0]
5-840-045	IEEE 802.11	WPA Debug Lvl	CTL*	[1 to 3/3/1]
5-840-046	IEEE 802.11	11w	CTL*	[0 to 2/0/1]
5-840-047	IEEE 802.11	PSK Set Type	CTL*	[0 to 1/0/1]
5-842-001	GWWS Analysis	Setting 1	CTL*	[0x00 to 0xFF/0/1]
5-842-002	GWWS Analysis	Setting 2	CTL*	[0x00 to 0xFF/0/1]
5-844-001	USB	Transfer Rate	CTL*	[1 to 4/4/0]
5-844-002	USB	Vendor ID	CTL*	[0x0000 to 0xffff/0x05ca/0]
5-844-003	USB	Product ID	CTL*	[0x0000 to 0xffff/0x0403/0]
5-844-004	USB	Device Release Number	CTL*	[0 to 9999/100/1]
5-844-005	USB	Fixed USB Port	CTL*	[0 to 2/0/1]

### 3.SP Mode Tables

SP No.	Large Category	Small Category	ENG or CTL	[Min to Max/Init./Step]
5-844-006	USB	PnP Model Name	CTL*	[0 to 0/0/0]
5-844-007	USB	PnP Serial Number	CTL*	[0 to 0/0/0]
5-844-008	USB	Mac Supply Level	CTL*	[0 to 1/1/1]
5-844-009	USB	USB Toggle Clear Mode	CTL*	[0 to 1/0/1]
5-844-100	USB	Notify Unsupport	CTL*	[0 to 1/1/1]
5-845-022	Delivery Srv	InstantTrans Off	CTL*	[0 to 1/1/1]
5-846-010	UCS Setting	LDAP Search TOut	CTL*	[1 to 255/60/1]
5-846-041	UCS Setting	AddrB Acl Info	CTL	[0 to 0/0/0]
5-846-043	UCS Setting	AddrB Media	CTL*	[0 to 30/0/1]
5-846-047	UCS Setting	Ini Local AddrB	CTL	[0 to 0/0/0]
5-846-049	UCS Setting	Ini LDAP AddrB	CTL	[0 to 0/0/0]
5-846-050	UCS Setting	Ini All AddrB	CTL	[0 to 0/0/0]

## 3.SP Mode Tables

SP No.	Large Category	Small Category	ENG or CTL	[Min to Max/Init./Step]
5-846-051	UCS Setting	Bkup All AddrB	CTL	[0 to 0/0/0]
5-846-052	UCS Setting	Restr All AddrB	CTL	[0 to 0/0/0]
5-846-053	UCS Setting	Clear Backup Info	CTL	[0 to 0/0/0]
5-846-060	UCS Setting	Search option	CTL*	[0x00 to 0xff/0x0f/1]
5-846-062	UCS Setting	Compl Opt1	CTL*	[0 to 32/0/1]
5-846-063	UCS Setting	Compl Opt2	CTL*	[0 to 32/0/1]
5-846-064	UCS Setting	Compl Opt3	CTL*	[0 to 32/0/1]
5-846-065	UCS Setting	Compl Opt4	CTL*	[0 to 32/0/1]
5-846-094	UCS Setting	Encryption Stat	CTL*	[0 to 255/0/0]
5-846-100	UCS Setting	Init Supervisor	CTL	[0 to 0/0/0]
5-848-004	Web Service	ac:UD	CTL*	[0x00 to 0xFF/0x00/0]
5-848-009	Web Service	ac:Job Ctrl	CTL*	[0x00 to 0xFF/0x00/0]

### 3.SP Mode Tables

SP No.	Large Category	Small Category	ENG or CTL	[Min to Max/Init./Step]
5-848-011	Web Service	ac:Dev Mng	CTL*	[0x00 to 0xFF/0x00/0]
5-848-022	Web Service	ac:Uadmin	CTL*	[0x00 to 0xFF/0x00/0]
5-848-024	Web Service	ac:Log	CTL*	[0x00 to 0xFF/0x00/0]
5-848-025	Web Service	ac:Rest	CTL*	[0x00 to 0xFF/0x00/0]
5-848-045	Web Service	ReverseProxy	CTL*	[0x00 to 0xFF/0/1]
5-848-046	Web Service	PortOpenTime	CTL*	[0 to 300/60/1]
5-848-150	WebService	LogOpeMode	CTL*	[0 to 2/0/1]
5-848-217	LogTrans	Timing	CTL*	[0 to 2/0/1]
5-849-001	Installation Date	Display	CTL*	[0 to 0/0/0]
5-849-002	Installation Date	Print	CTL*	[0 to 1/1/1]
5-849-003	Installation Date	Total Counter	CTL*	[0 to 99999999/0/1]
5-851-001	Bluetooth	Mode	CTL*	[0x00 to 0x01/0x00/1]

SP No.	Large Category	Small Category	ENG or CTL	[Min to Max/Init./Step]
5-856-002	Remote ROM Update	Local Port	CTL	[0 to 1/0/1]
5-858-001	Save Machine Info	0:OFF 1:ON	CTL	[0 to 1/1/1]
5-858-002	Save Machine Info	Target 0:HDD 1:SD	CTL	[0 to 1/0/1]
5-858-003	Save Machine Info	Make LogTrace Dir	CTL	[0 to 1/0/0]
5-858-101	Save Machine Info	Start Date	CTL	[0 to 20371212/0/1]
5-858-102	Save Machine Info	Days	CTL	[1 to 180/2/1day]
5-858-103	Save Machine Info	Fax Mask	CTL	[0 to 1/0/1]
5-858-111	Save Machine Info	All Info & Logs	CTL	[0 to 1/0/0]
5-858-121	Save Machine Info	ConfigurationPage	CTL	[0 to 1/0/0]
5-858-122	Save Machine Info	FontPage	CTL	[0 to 1/0/0]
5-858-123	Save Machine Info	PrintSettingList	CTL	[0 to 1/0/0]
5-858-124	Save Machine Info	ErrorLog	CTL	[0 to 1/0/0]

### 3.SP Mode Tables

SP No.	Large Category	Small Category	ENG or CTL	[Min to Max/Init./Step]
5-858-131	Save Machine Info	FaxInfo	CTL	[0 to 1/0/0]
5-858-141	Save Machine Info	All Logs	CTL	[0 to 1/0/0]
5-858-142	Save Machine Info	ControllerLogs	CTL	[0 to 1/0/0]
5-858-143	Save Machine Info	EngineDebugLogs	CTL	[0 to 1/0/0]
5-858-144	Save Machine Info	OpepanelDebugLogs	CTL	[0 to 1/0/0]
5-858-145	Save Machine Info	FCU DebugLogs	CTL	[0 to 1/0/0]
5-858-146	Save Machine Info	Network Packets	CTL	[0 to 1/0/0]
5-860-020	SMTP/POP3/IMAP4	ParMail RecTOut	CTL *	[1 to 168/72/1hour]
5-860-021	SMTP/POP3/IMAP4	MDN ResRFC2298	CTL *	[0 to 1/1/1]
5-860-022	SMTP/POP3/IMAP4	SMTPAut FieldRep	CTL *	[0 to 1/0/1]
5-860-025	SMTP/POP3/IMAP4	SMTPAut DirectSet	CTL *	[0 to 0xff/0x0/1]
5-860-026	SMTP/POP3/IMAP4	S/MIME Header	CTL *	[0 to 2/0/1]

## 3.SP Mode Tables

SP No.	Large Category	Small Category	ENG or CTL	[Min to Max/Init./Step]
5-866-028	SMTP/POP3/IMAP4	S/MIME Check	CTL*	[0 to 1/0/1]
5-866-001	E-Mail Report	Report Validity	CTL	[0 to 1/0/1]
5-866-005	E-Mail Report	Add Date Field	CTL*	[0 to 1/0/1]
5-866-109	E-Mail Report	CounterE-Mail:3G Line Validity	CTL*	[0 to 1/0/1]
5-866-110	E-Mail Report	CounterE-Mail:Validity	CTL*	[0 to 1/0/1]
5-866-111	E-Mail Report	CounterE-Mail:Destination Registration	CTL*	[0 to 0/0/0]
5-866-112	E-Mail Report	CounterE-Mail:Send Test	CTL*	[0 to 0/0/0]
5-866-113	E-Mail Report	CounterE-Mail:Next Send Date	CTL*	[0 to 0/0/0]
5-866-114	E-Mail Report	CounterE-Mail:Send Date Setting	CTL*	[0 to 31/0/1]
5-866-115	E-Mail Report	CounterE-Mail:Send Time Setting	CTL*	[0 to 2359/0/1]
5-866-121	E-Mail Report	CounterE-Mail:Destination1	CTL*	[0 to 0/0/0]
5-866-122	E-Mail Report	CounterE-Mail:Destination2	CTL*	[0 to 0/0/0]

### 3.SP Mode Tables

SP No.	Large Category	Small Category	ENG or CTL	[Min to Max/Init./Step]
5-866-123	E-Mail Report	CounterE-Mail:Destination3	CTL*	[0 to 0/0/0]
5-869-001	RAM Disk Setting	Mail Function	CTL*	[0 to 1/0/1]
5-870-001	Common KeyInfo Writing	Writing	CTL	[0 to 1/0/1]
5-870-003	Common KeyInfo Writing	Initialize	CTL	[0 to 1/0/1]
5-870-004	Com Key Info WR	Writing: 2048bit	CTL	[0 to 1/0/1]
5-873-001	SDCardAppliMove	MoveExec	CTL	[0 to 0/0/1]
5-873-002	SDCardAppliMove	UndoExec	CTL	[0 to 0/0/1]
5-875-001	SC Auto Reboot	Reboot Mode	CTL*	[0 to 1/0/1]
5-875-002	SC Auto Reboot	Reboot Method	CTL*	[0 to 1/0/1]
5-878-001	Option Setup	DataOverwriteSec.	CTL	[0 to 0/0/0]
5-878-002	Option Setup	HDD Encryption	CTL	[0 to 0/0/0]
5-885-205	Set WIM Function	MonitorDisable	CTL*	[0 to 1/0/1]

## 3.SP Mode Tables

SP No.	Large Category	Small Category	ENG or CTL	[Min to Max/Init./Step]
5-887-001	SD GetCounter		CTL	[0 to 0/0/0]
5-888-001	Person. InfoProt.		CTL*	[0 to 1/0/1]
5-893-001	SDK Apli Cnt Name	SDK-1	CTL	[0 to 0/0/0]
5-893-002	SDK Apli Cnt Name	SDK-2	CTL	[0 to 0/0/0]
5-893-003	SDK Apli Cnt Name	SDK-3	CTL	[0 to 0/0/0]
5-893-004	SDK Apli Cnt Name	SDK-4	CTL	[0 to 0/0/0]
5-893-005	SDK Apli Cnt Name	SDK-5	CTL	[0 to 0/0/0]
5-893-006	SDK Apli Cnt Name	SDK-6	CTL	[0 to 0/0/0]
5-893-007	SDK Apli Cnt Name	SDK-7	CTL	[0 to 0/0/0]
5-893-008	SDK Apli Cnt Name	SDK-8	CTL	[0 to 0/0/0]
5-893-009	SDK Apli Cnt Name	SDK-9	CTL	[0 to 0/0/0]
5-893-010	SDK Apli Cnt Name	SDK-10	CTL	[0 to 0/0/0]

### 3.SP Mode Tables

SP No.	Large Category	Small Category	ENG or CTL	[Min to Max/Init./Step]
5-893-011	SDK Apli Cnt Name	SDK-11	CTL	[0 to 0/0/0]
5-893-012	SDK Apli Cnt Name	SDK-12	CTL	[0 to 0/0/0]
5-907-001	Plug & Play		CTL*	[0 to 255/0/1]
5-985-002	Device Setting	On Board USB	CTL	[0 to 1/0/1]
5-990-001	SP Print Mode	All	CTL	[0 to 255/0/0]
5-990-002	SP Print Mode	SP	CTL	[0 to 255/0/0]
5-990-004	SP Print Mode	Logging Data	CTL	[0 to 255/0/0]
5-990-005	SP Print Mode	Diagnostic Report	CTL	[0 to 255/0/0]
5-990-006	SP Print Mode	Non-Default	CTL	[0 to 255/0/0]
5-990-007	SP Print Mode	NIB Summary	CTL	[0 to 0/0/0]
5-990-024	SP Print Mode	SDK/J Summary	CTL	[0 to 0/0/0]
5-990-025	SP Print Mode	SDK/J Appli. Info	CTL	[0 to 0/0/0]

## 3.SP Mode Tables

SP No.	Large Category	Small Category	ENG or CTL	[Min to Max/Init./Step]
5-990-026	SP Print Mode	Printer SP	CTL	[0 to 255/0/0]
5-992-001	SP Text Mode	All	CTL	[0 to 255/0/0]
5-992-002	SP Text Mode	SP	CTL	[0 to 255/0/0]
5-992-004	SP Text Mode	Logging Data	CTL	[0 to 255/0/0]
5-992-005	SP Text Mode	Diagnostic Report	CTL	[0 to 255/0/0]
5-992-006	SP Text Mode	Non-Default	CTL	[0 to 255/0/0]
5-992-007	SP Text Mode	NIB Summary	CTL	[0 to 0/0/0]
5-992-024	SP Text Mode	SDK/J Summary	CTL	[0 to 0/0/0]
5-992-025	SP Text Mode	SDK/J Appli. Info	CTL	[0 to 0/0/0]
5-992-026	SP Text Mode	Printer SP	CTL	[0 to 255/0/0]

## Main SP Tables-7 (Engine)

### SP7-XXX (Data Log)

SP No.	Large Category	Small Category	ENG or CTL	[Min to Max/Init./Step]
7-621-002	PM Counter Pages	# PCU:Bk	ENG*	[0 to 99999999/0/1page]
7-621-003	PM Counter Pages	# Dev Unit:Bk	ENG*	[0 to 99999999/0/1page]
7-621-025	PM Counter Pages	# PCU:C	ENG*	[0 to 99999999/0/1page]
7-621-026	PM Counter Pages	# Dev Unit:C	ENG*	[0 to 99999999/0/1page]
7-621-048	PM Counter Pages	# PCU:M	ENG*	[0 to 99999999/0/1page]
7-621-049	PM Counter Pages	# Dev Unit:M	ENG*	[0 to 99999999/0/1page]
7-621-071	PM Counter Pages	# PCU:Y	ENG*	[0 to 99999999/0/1page]
7-621-072	PM Counter Pages	# Dev Unit:Y	ENG*	[0 to 99999999/0/1page]
7-621-093	PM Counter Pages	# ITB Unit	ENG*	[0 to 99999999/0/1page]
7-621-109	PM Counter Pages	# PTR Unit	ENG*	[0 to 99999999/0/1page]
7-621-115	PM Counter Pages	# Fusing Unit	ENG*	[0 to 99999999/0/1page]
7-621-146	PM Counter Pages	# Feed Roller	ENG*	[0 to 99999999/0/1sheet]
7-621-147	PM Counter Pages	# Pickup Roller	ENG*	[0 to 99999999/0/1sheet]
7-621-148	PM Counter Pages	# Separate Roller	ENG*	[0 to 99999999/0/1sheet]
7-622-002	PM Counter Clear	# PCU:Bk	ENG	[0 to 1/0/1]
7-622-003	PM Counter Clear	# Dev Unit:Bk	ENG	[0 to 1/0/1]
7-622-	PM Counter	# PCU:C	ENG	[0 to 1/0/1]

## 3.SP Mode Tables

SP No.	Large Category	Small Category	ENG or CTL	[Min to Max/Init./Step]
025	Clear			
7-622-026	PM Counter Clear	# Dev Unit:C	ENG	[0 to 1/0/1]
7-622-048	PM Counter Clear	# PCU:M	ENG	[0 to 1/0/1]
7-622-049	PM Counter Clear	# Dev Unit:M	ENG	[0 to 1/0/1]
7-622-071	PM Counter Clear	# PCU:Y	ENG	[0 to 1/0/1]
7-622-072	PM Counter Clear	# Dev Unit:Y	ENG	[0 to 1/0/1]
7-622-093	PM Counter Clear	# ITB Unit	ENG	[0 to 1/0/1]
7-622-109	PM Counter Clear	# PTR Unit	ENG	[0 to 1/0/1]
7-622-115	PM Counter Clear	# Fusing Unit	ENG	[0 to 1/0/1]
7-622-146	PM Counter Clear	# Feed Roller	ENG	[0 to 1/0/1]
7-622-147	PM Counter Clear	# Pickup Roller	ENG	[0 to 1/0/1]
7-622-148	PM Counter Clear	# Separate Roller	ENG	[0 to 1/0/1]
7-625-002	PreCounter1 Pages	# PCU:Bk	ENG	[0 to 99999999/0/1page]
7-625-003	PreCounter1 Pages	# Dev Unit:Bk	ENG	[0 to 99999999/0/1page]
7-625-025	PreCounter1 Pages	# PCU:C	ENG	[0 to 99999999/0/1page]
7-625-026	PreCounter1 Pages	# Dev Unit:C	ENG	[0 to 99999999/0/1page]
7-625-048	PreCounter1 Pages	# PCU:M	ENG	[0 to 99999999/0/1page]
7-625-049	PreCounter1 Pages	# Dev Unit:M	ENG	[0 to 99999999/0/1page]
7-625-	PreCounter1	# PCU:Y	ENG	[0 to 99999999/0/1page]

### 3.SP Mode Tables

SP No.	Large Category	Small Category	ENG or CTL	[Min to Max/Init./Step]
071	Pages			
7-625-072	PreCounter1 Pages	# Dev Unit:Y	ENG	[0 to 99999999/0/1page]
7-625-093	PreCounter1 Pages	# ITB Unit	ENG	[0 to 99999999/0/1page]
7-625-109	PreCounter1 Pages	# PTR Unit	ENG	[0 to 99999999/0/1page]
7-625-115	PreCounter1 Pages	# Fusing Unit	ENG	[0 to 99999999/0/1page]
7-625-146	PreCounter1 Pages	# Feed Roller	ENG	[0 to 99999999/0/1sheet]
7-625-147	PreCounter1 Pages	# Pickup Roller	ENG	[0 to 99999999/0/1sheet]
7-625-148	PreCounter1 Pages	# Separate Roller	ENG	[0 to 99999999/0/1sheet]
7-626-002	PreCounter2 Pages	# PCU:Bk	ENG	[0 to 99999999/0/1page]
7-626-003	PreCounter2 Pages	# Dev Unit:Bk	ENG	[0 to 99999999/0/1page]
7-626-025	PreCounter2 Pages	# PCU:C	ENG	[0 to 99999999/0/1page]
7-626-026	PreCounter2 Pages	# Dev Unit:C	ENG	[0 to 99999999/0/1page]
7-626-048	PreCounter2 Pages	# PCU:M	ENG	[0 to 99999999/0/1page]
7-626-049	PreCounter2 Pages	# Dev Unit:M	ENG	[0 to 99999999/0/1page]
7-626-071	PreCounter2 Pages	# PCU:Y	ENG	[0 to 99999999/0/1page]
7-626-072	PreCounter2 Pages	# Dev Unit:Y	ENG	[0 to 99999999/0/1page]
7-626-093	PreCounter2 Pages	# ITB Unit	ENG	[0 to 99999999/0/1page]
7-626-109	PreCounter2 Pages	# PTR Unit	ENG	[0 to 99999999/0/1page]
7-626-	PreCounter2	# Fusing Unit	ENG	[0 to 99999999/0/1page]

## 3.SP Mode Tables

SP No.	Large Category	Small Category	ENG or CTL	[Min to Max/Init./Step]
115	Pages			
7-626-146	PreCounter2 Pages	# Feed Roller	ENG	[0 to 99999999/0/1sheet]
7-626-147	PreCounter2 Pages	# Pickup Roller	ENG	[0 to 99999999/0/1sheet]
7-626-148	PreCounter2 Pages	# Separate Roller	ENG	[0 to 99999999/0/1sheet]
7-801-002	ROM Info Display	P#: Engine	ENG	[0 to 0/0/0]
7-801-009	ROM Info Display	P#: PFU1	ENG	[0 to 0/0/0]
7-801-015	ROM Info Display	P#: IPU	ENG	[0 to 0/0/0]
7-801-019	ROM Info Display	P#: PFU2	ENG	[0 to 0/0/0]
7-801-040	ROM Info Display	P#: PFU3	ENG	[0 to 0/0/0]
7-801-102	ROM Info Display	Version: Engine	ENG	[0 to 0/0/0]
7-801-109	ROM Info Display	Version:PFU1	ENG	[0 to 0/0/0]
7-801-115	ROM Info Display	Version: IPU	ENG	[0 to 0/0/0]
7-801-119	ROM Info Display	Version:PFU2	ENG	[0 to 0/0/0]
7-801-140	ROM Info Display	Version:PFU3	ENG	[0 to 0/0/0]
7-853-002	Replace Counter	# PCU:Bk	ENG	[0 to 255/0/1]
7-853-003	Replace Counter	# Dev Unit:Bk	ENG	[0 to 255/0/1]
7-853-025	Replace Counter	# PCU:C	ENG	[0 to 255/0/1]
7-853-026	Replace Counter	# Dev Unit:C	ENG	[0 to 255/0/1]
7-853-	Replace	# PCU:M	ENG	[0 to 255/0/1]

### 3.SP Mode Tables

SP No.	Large Category	Small Category	ENG or CTL	[Min to Max/Init./Step]
048	Counter			
7-853-049	Replace Counter	# Dev Unit:M	ENG	[0 to 255/0/1]
7-853-071	Replace Counter	# PCU:Y	ENG	[0 to 255/0/1]
7-853-072	Replace Counter	# Dev Unit:Y	ENG	[0 to 255/0/1]
7-853-093	Replace Counter	# ITB Unit	ENG	[0 to 255/0/1]
7-853-109	Replace Counter	# PTR Unit	ENG	[0 to 255/0/1]
7-853-115	Replace Counter	# Fusing Unit	ENG	[0 to 255/0/1]
7-853-146	Replace Counter	# Feed Roller	ENG	[0 to 255/0/1]
7-853-147	Replace Counter	# Pickup Roller	ENG	[0 to 255/0/1]
7-853-148	Replace Counter	# Separate Roller	ENG	[0 to 255/0/1]
7-931-001	Toner Bottle	K/C	ENG	[0 to 255/0/1]
7-931-002	Toner Bottle	M/Y	ENG	[0 to 255/0/1]
7-932-001	Drum Unit	SerialNo.K	ENG	[0 to 255/0/1]
7-932-002	Drum Unit	SerialNo.C	ENG	[0 to 255/0/1]
7-932-003	Drum Unit	SerialNo.M	ENG	[0 to 255/0/1]
7-932-004	Drum Unit	SerialNo.Y	ENG	[0 to 255/0/1]
7-933-001	Dev Unit	SerialNo.K	ENG	[0 to 255/0/1]
7-933-002	Dev Unit	SerialNo.C	ENG	[0 to 255/0/1]
7-933-003	Dev Unit	SerialNo.M	ENG	[0 to 255/0/1]

## 3.SP Mode Tables

SP No.	Large Category	Small Category	ENG or CTL	[Min to Max/Init./Step]
003				
7-933-004	Dev Unit	SerialNo.Y	ENG	[0 to 255/0/1]
7-934-001	Toner Bottle	Name.K	ENG	[0 to 255/0/1]
7-934-002	Toner Bottle	Name.C	ENG	[0 to 255/0/1]
7-934-003	Toner Bottle	Name.M	ENG	[0 to 255/0/1]
7-934-004	Toner Bottle	Name.Y	ENG	[0 to 255/0/1]
7-935-001	Toner Bottle Log	SerialNo.K	ENG*	[0 to 255/0/1]
7-935-002	Toner Bottle Log	SerialNo.C	ENG*	[0 to 255/0/1]
7-935-003	Toner Bottle Log	SerialNo.M	ENG*	[0 to 255/0/1]
7-935-004	Toner Bottle Log	SerialNo.Y	ENG*	[0 to 255/0/1]
7-944-002	PM Cnt Dis	#PCU:Bk	ENG	[0 to 4294967295/0/1m] DFU Design/Factory Use only: Do not touch these SP modes in the field.
7-944-003	PM Cnt Dis	#Dev Unit:Bk	ENG	[0 to 4294967295/0/1m] DFU Design/Factory Use only: Do not touch these SP modes in the field.
7-944-025	PM Cnt Dis	#PCU:C	ENG	[0 to 4294967295/0/1m] DFU Design/Factory Use only: Do not touch these SP modes in the field.
7-944-026	PM Cnt Dis	#Dev Unit:C	ENG	[0 to 4294967295/0/1m] DFU Design/Factory Use only: Do not touch these SP modes in the field.
7-944-048	PM Cnt Dis	#PCU:M	ENG	[0 to 4294967295/0/1m] DFU Design/Factory Use only: Do not touch these SP modes in the field.
7-944-049	PM Cnt Dis	#Dev Unit:M	ENG	[0 to 4294967295/0/1m] DFU Design/Factory Use only: Do not touch

### 3.SP Mode Tables

SP No.	Large Category	Small Category	ENG or CTL	[Min to Max/Init./Step]
				these SP modes in the field.
7-944-071	PM Cnt Dis	#PCU:Y	ENG	[0 to 4294967295/0/1m] DFU Design/Factory Use only: Do not touch these SP modes in the field.
7-944-072	PM Cnt Dis	#Dev Unit:Y	ENG	[0 to 4294967295/0/1m] DFU Design/Factory Use only: Do not touch these SP modes in the field.
7-954-002	Counter: Pages(%)	# PCU:Bk	ENG*	[0 to 255/0/1%]
7-954-003	Counter: Pages(%)	# Dev Unit:Bk	ENG*	[0 to 255/0/1%]
7-954-025	Counter: Pages(%)	# PCU:C	ENG*	[0 to 255/0/1%]
7-954-026	Counter: Pages(%)	# Dev Unit:C	ENG*	[0 to 255/0/1%]
7-954-048	Counter: Pages(%)	# PCU:M	ENG*	[0 to 255/0/1%]
7-954-049	Counter: Pages(%)	# Dev Unit:M	ENG*	[0 to 255/0/1%]
7-954-071	Counter: Pages(%)	# PCU:Y	ENG*	[0 to 255/0/1%]
7-954-072	Counter: Pages(%)	# Dev Unit:Y	ENG*	[0 to 255/0/1%]
7-954-093	Counter: Pages(%)	# ITB Unit	ENG*	[0 to 255/0/1%]
7-954-109	Counter: Pages(%)	# PTR Unit	ENG*	[0 to 255/0/1%]
7-954-115	Counter: Pages(%)	# Fusing Unit	ENG*	[0 to 255/0/1%]
7-954-146	Counter: Pages(%)	# Feed Roller	ENG*	[0 to 255/0/1%]
7-954-147	Counter: Pages(%)	# Pickup Roller	ENG*	[0 to 255/0/1%]
7-954-148	Counter: Pages(%)	# Separate Roller	ENG*	[0 to 255/0/1%]
7-979-	CPU Reset Log	Data1	ENG*	[0x00 to 0xFF/0x00/1]

SP No.	Large Category	Small Category	ENG or CTL	[Min to Max/Init./Step]
001				
7-779-002	CPU Reset Log	Data2	ENG*	[0x0000 to 0xFFFF/0x0000/1]
7-779-003	CPU Reset Log	Data3	ENG*	[0x0000 to 0xFFFF/0x0000/1]
7-779-004	CPU Reset Log	Data4	ENG*	[0x0000 to 0xFFFF/0x0000/1]
7-779-005	CPU Reset Log	Data5	ENG*	[0x0000 to 0xFFFF/0x0000/1]
7-779-006	CPU Reset Log	Data6	ENG*	[0x0000 to 0xFFFF/0x0000/1]
7-779-007	CPU Reset Log	Data7	ENG*	[0x0000 to 0xFFFF/0x0000/1]
7-779-008	CPU Reset Log	Data8	ENG*	[0x0000 to 0xFFFF/0x0000/1]
7-779-009	CPU Reset Log	Data9	ENG*	[0x0000 to 0xFFFF/0x0000/1]
7-779-010	CPU Reset Log	Data10	ENG*	[0x0000 to 0xFFFF/0x0000/1]
7-779-011	CPU Reset Log	Data11	ENG*	[0x0000 to 0xFFFF/0x0000/1]
7-779-012	CPU Reset Log	Data12	ENG*	[0x0000 to 0xFFFF/0x0000/1]
7-779-013	CPU Reset Log	Data13	ENG*	[0x0000 to 0xFFFF/0x0000/1]
7-779-014	CPU Reset Log	Data14	ENG*	[0x0000 to 0xFFFF/0x0000/1]
7-779-015	CPU Reset Log	Data15	ENG*	[0x0000 to 0xFFFF/0x0000/1]
7-779-016	CPU Reset Log	Data16	ENG*	[0x0000 to 0xFFFF/0x0000/1]
7-779-017	CPU Reset Log	Data17	ENG*	[0x0000 to 0xFFFF/0x0000/1]
7-779-018	CPU Reset Log	Data18	ENG*	[0x0000 to 0xFFFF/0x0000/1]
7-779-	CPU Reset Log	Data19	ENG*	[0x0000 to 0xFFFF/0x0000/1]

### 3.SP Mode Tables

SP No.	Large Category	Small Category	ENG or CTL	[Min to Max/Init./Step]
019				
7-979-020	CPU Reset Log	Data20	ENG*	[0x0000 to 0xFFFF/0x0000/1]
7-979-021	CPU Reset Log	Data21	ENG*	[0x0000 to 0xFFFF/0x0000/1]

## Main SP Tables-7 (Controller)

### SP7-XXX (Data Log)

SP No.	Large Category	Small Category	ENG or CTL	[Min to Max/Init./Step]
7-401-001	Total SC	SC Counter	CTL*	[0 to 65535/0/0]
7-401-002	Total SC	Total SC Counter	CTL*	[0 to 65535/0/0]
7-403-001	SC History	Latest	CTL*	[0 to 0/0/0]
7-403-002	SC History	Latest 1	CTL*	[0 to 0/0/0]
7-403-003	SC History	Latest 2	CTL*	[0 to 0/0/0]
7-403-004	SC History	Latest 3	CTL*	[0 to 0/0/0]
7-403-005	SC History	Latest 4	CTL*	[0 to 0/0/0]
7-403-006	SC History	Latest 5	CTL*	[0 to 0/0/0]
7-403-007	SC History	Latest 6	CTL*	[0 to 0/0/0]
7-403-008	SC History	Latest 7	CTL*	[0 to 0/0/0]
7-403-009	SC History	Latest 8	CTL*	[0 to 0/0/0]
7-403-010	SC History	Latest 9	CTL*	[0 to 0/0/0]
7-404-001	SW Error History	Latest	CTL*	[0 to 0/0/0]
7-404-002	SW Error History	Latest 1	CTL*	[0 to 0/0/0]
7-404-003	SW Error History	Latest 2	CTL*	[0 to 0/0/0]
7-404-004	SW Error History	Latest 3	CTL*	[0 to 0/0/0]
7-404-005	SW Error History	Latest 4	CTL*	[0 to 0/0/0]
7-404-006	SW Error History	Latest 5	CTL*	[0 to 0/0/0]
7-404-007	SW Error History	Latest 6	CTL*	[0 to 0/0/0]
7-404-008	SW Error History	Latest 7	CTL*	[0 to 0/0/0]
7-404-009	SW Error History	Latest 8	CTL*	[0 to 0/0/0]
7-404-010	SW Error History	Latest 9	CTL*	[0 to 0/0/0]
7-502-001	Total Paper Jam	Jam Counter	CTL*	[0 to 65535/0/0]
7-502-002	Total Paper Jam	Total Jam Counter	CTL*	[0 to 65535/0/0]
7-504-001	Paper Jam Loc	At Power On	CTL*	[0 to 65535/0/0]
7-504-010	Paper Jam Loc	ProcPkg:NotRdy	CTL*	[0 to 65535/0/0]
7-504-011	Paper Jam Loc	TrnspPkg:NotRdy	CTL*	[0 to 65535/0/0]
7-504-012	Paper Jam Loc	DrvNotStp	CTL*	[0 to 65535/0/0]
7-504-013	Paper Jam Loc	DxFd:NoCtlSig	CTL*	[0 to 65535/0/0]
7-504-014	Paper Jam Loc	FusPkg:NotRdy	CTL*	[0 to 65535/0/0]
7-504-015	Paper Jam Loc	SecFd:NoCtlSig	CTL*	[0 to 65535/0/0]
7-504-016	Paper Jam Loc	RearCvrOpen	CTL*	[0 to 65535/0/0]
7-504-017	Paper Jam Loc	TopCvrOpen	CTL*	[0 to 65535/0/0]
7-504-019	Paper Jam Loc	Tray1:On	CTL*	[0 to 65535/0/0]

### 3.SP Mode Tables

SP No.	Large Category	Small Category	ENG or CTL	[Min to Max/Init./Step]
7-504-020	Paper Jam Loc	Duplex:On	CTL*	[0 to 65535/0/0]
7-504-021	Paper Jam Loc	Bypass:On	CTL*	[0 to 65535/0/0]
7-504-022	Paper Jam Loc	Tray1:Cont	CTL*	[0 to 65535/0/0]
7-504-023	Paper Jam Loc	Tray2:Cont	CTL*	[0 to 65535/0/0]
7-504-024	Paper Jam Loc	Tray3:Cont	CTL*	[0 to 65535/0/0]
7-504-025	Paper Jam Loc	Tray4:Cont	CTL*	[0 to 65535/0/0]
7-504-026	Paper Jam Loc	Duplex:Cont	CTL*	[0 to 65535/0/0]
7-504-027	Paper Jam Loc	Bypass:Cont	CTL*	[0 to 65535/0/0]
7-504-028	Paper Jam Loc	Fd2Sn:OnCass3Fd	CTL*	[0 to 65535/0/0]
7-504-029	Paper Jam Loc	Fd2Sn:OnCass4Fd	CTL*	[0 to 65535/0/0]
7-504-030	Paper Jam Loc	Fd2Sn:OffCass3Fd	CTL*	[0 to 65535/0/0]
7-504-031	Paper Jam Loc	Fd2Sn:OffCass4Fd	CTL*	[0 to 65535/0/0]
7-504-032	Paper Jam Loc	Fd3Sn:OnCass4Fd2	CTL*	[0 to 65535/0/0]
7-504-033	Paper Jam Loc	Fd3Sn:OffCass4Fd	CTL*	[0 to 65535/0/0]
7-504-034	Paper Jam Loc	RegSn:OnCass2Fd	CTL*	[0 to 65535/0/0]
7-504-035	Paper Jam Loc	RegSn:OnCass3Fd	CTL*	[0 to 65535/0/0]
7-504-036	Paper Jam Loc	RegSn:OnCass4Fd	CTL*	[0 to 65535/0/0]
7-504-037	Paper Jam Loc	RegSn:OnMPFFd	CTL*	[0 to 65535/0/0]
7-504-038	Paper Jam Loc	RegSn:OffCass2Fd	CTL*	[0 to 65535/0/0]
7-504-039	Paper Jam Loc	RegSn:OffCass3Fd	CTL*	[0 to 65535/0/0]
7-504-040	Paper Jam Loc	RegSn:OffCass4Fd	CTL*	[0 to 65535/0/0]
7-504-041	Paper Jam Loc	RegSn:OffMPFFd	CTL*	[0 to 65535/0/0]
7-504-042	Paper Jam Loc	ExtSn:OnCass1Fd	CTL*	[0 to 65535/0/0]
7-504-043	Paper Jam Loc	ExtSn:OnCass2Fd	CTL*	[0 to 65535/0/0]
7-504-044	Paper Jam Loc	ExtSn:OnCass3Fd	CTL*	[0 to 65535/0/0]
7-504-045	Paper Jam Loc	ExtSn:OnCass4Fd	CTL*	[0 to 65535/0/0]
7-504-046	Paper Jam Loc	ExtSn:OnDxFd	CTL*	[0 to 65535/0/0]
7-504-047	Paper Jam Loc	ExtSn:OnMPFFd	CTL*	[0 to 65535/0/0]
7-504-048	Paper Jam Loc	ExtSn:OffCass1Fd	CTL*	[0 to 65535/0/0]
7-504-049	Paper Jam Loc	ExtSn:OffCass2Fd	CTL*	[0 to 65535/0/0]
7-504-050	Paper Jam Loc	ExtSn:OffCass3Fd	CTL*	[0 to 65535/0/0]
7-504-051	Paper Jam Loc	ExtSn:OffCass4Fd	CTL*	[0 to 65535/0/0]
7-504-052	Paper Jam Loc	ExtSn:OffDxFd	CTL*	[0 to 65535/0/0]
7-504-053	Paper Jam Loc	ExtSn:OffMPFFd	CTL*	[0 to 65535/0/0]
7-504-054	Paper Jam Loc	DxTPSn:OnCass1Fd	CTL*	[0 to 65535/0/0]
7-504-055	Paper Jam Loc	DxTPSn:OnCass2Fd	CTL*	[0 to 65535/0/0]
7-504-056	Paper Jam Loc	DxTPSn:OnCass3Fd	CTL*	[0 to 65535/0/0]

## 3.SP Mode Tables

SP No.	Large Category	Small Category	ENG or CTL	[Min to Max/Init./Step]
7-504-057	Paper Jam Loc	DxTPSn:OnCass4Fd	CTL*	[0 to 65535/0/0]
7-504-058	Paper Jam Loc	DxTPSn:OnMPFFd	CTL*	[0 to 65535/0/0]
7-504-059	Paper Jam Loc	DxTPSn:OffCass1Fd	CTL*	[0 to 65535/0/0]
7-504-060	Paper Jam Loc	DxTPSn:OffCass2Fd	CTL*	[0 to 65535/0/0]
7-504-061	Paper Jam Loc	DxTPSn:OffCass3Fd	CTL*	[0 to 65535/0/0]
7-504-062	Paper Jam Loc	DxTPSn:OffCass4Fd	CTL*	[0 to 65535/0/0]
7-504-063	Paper Jam Loc	DxTPSn:OffMPFFd	CTL*	[0 to 65535/0/0]
7-504-099	Paper Jam Loc	Tray2:Off2	CTL*	[0 to 65535/0/0]
7-504-100	Paper Jam Loc	Tray2:RearCvrOpen	CTL*	[0 to 65535/0/0]
7-504-101	Paper Jam Loc	Tray3:Off	CTL*	[0 to 65535/0/0]
7-504-102	Paper Jam Loc	Tray3:RearCvrOpen	CTL*	[0 to 65535/0/0]
7-504-103	Paper Jam Loc	Tray4:Off	CTL*	[0 to 65535/0/0]
7-504-104	Paper Jam Loc	Tray4:RearCvrOpen	CTL*	[0 to 65535/0/0]
7-506-006	Paper Jam/Size	A5 LEF	CTL*	[0 to 65535/0/0]
7-506-044	Paper Jam/Size	HLT LEF	CTL*	[0 to 65535/0/0]
7-506-133	Paper Jam/Size	A4 SEF	CTL*	[0 to 65535/0/0]
7-506-134	Paper Jam/Size	A5 SEF	CTL*	[0 to 65535/0/0]
7-506-142	Paper Jam/Size	B5 SEF	CTL*	[0 to 65535/0/0]
7-506-164	Paper Jam/Size	LG SEF	CTL*	[0 to 65535/0/0]
7-506-166	Paper Jam/Size	LT SEF	CTL*	[0 to 65535/0/0]
7-506-172	Paper Jam/Size	HLT SEF	CTL*	[0 to 65535/0/0]
7-506-255	Paper Jam/Size	Other	CTL*	[0 to 65535/0/0]
7-507-001	Dsply-P Jam Hist	Latest	CTL*	[0 to 0/0/0]
7-507-002	Dsply-P Jam Hist	Latest 1	CTL*	[0 to 0/0/0]
7-507-003	Dsply-P Jam Hist	Latest 2	CTL*	[0 to 0/0/0]
7-507-004	Dsply-P Jam Hist	Latest 3	CTL*	[0 to 0/0/0]
7-507-005	Dsply-P Jam Hist	Latest 4	CTL*	[0 to 0/0/0]
7-507-006	Dsply-P Jam Hist	Latest 5	CTL*	[0 to 0/0/0]
7-507-007	Dsply-P Jam Hist	Latest 6	CTL*	[0 to 0/0/0]
7-507-008	Dsply-P Jam Hist	Latest 7	CTL*	[0 to 0/0/0]
7-507-009	Dsply-P Jam Hist	Latest 8	CTL*	[0 to 0/0/0]
7-507-010	Dsply-P Jam Hist	Latest 9	CTL*	[0 to 0/0/0]
7-514-001	Paper Jam Cnt Loc	At Power On	CTL*	[0 to 65535/0/0]
7-514-010	Paper Jam Cnt Loc	ProcPkg:NotRdy	CTL*	[0 to 65535/0/0]
7-514-011	Paper Jam Cnt Loc	TrnspPkg:NotRdy	CTL*	[0 to 65535/0/0]
7-514-012	Paper Jam Cnt Loc	DrvNotStp	CTL*	[0 to 65535/0/0]
7-514-013	Paper Jam Cnt Loc	DxFd:NoCtlSig	CTL*	[0 to 65535/0/0]

### 3.SP Mode Tables

SP No.	Large Category	Small Category	ENG or CTL	[Min to Max/Init./Step]
7-514-014	Paper Jam Cnt Loc	FusPkg:NotRdy	CTL*	[0 to 65535/0/0]
7-514-015	Paper Jam Cnt Loc	SecFd:NoCtlSig	CTL*	[0 to 65535/0/0]
7-514-016	Paper Jam Cnt Loc	RearCvrOpen	CTL*	[0 to 65535/0/0]
7-514-017	Paper Jam Cnt Loc	TopCvrOpen	CTL*	[0 to 65535/0/0]
7-514-019	Paper Jam Cnt Loc	Tray1:On	CTL*	[0 to 65535/0/0]
7-514-020	Paper Jam Cnt Loc	Duplex:On	CTL*	[0 to 65535/0/0]
7-514-021	Paper Jam Cnt Loc	Bypass:On	CTL*	[0 to 65535/0/0]
7-514-022	Paper Jam Cnt Loc	Tray1:Cont	CTL*	[0 to 65535/0/0]
7-514-023	Paper Jam Cnt Loc	Tray2:Cont	CTL*	[0 to 65535/0/0]
7-514-024	Paper Jam Cnt Loc	Tray3:Cont	CTL*	[0 to 65535/0/0]
7-514-025	Paper Jam Cnt Loc	Tray4:Cont	CTL*	[0 to 65535/0/0]
7-514-026	Paper Jam Cnt Loc	Duplex:Cont	CTL*	[0 to 65535/0/0]
7-514-027	Paper Jam Cnt Loc	Bypass:Cont	CTL*	[0 to 65535/0/0]
7-514-028	Paper Jam Cnt Loc	Fd2Sn:OnCass3Fd	CTL*	[0 to 65535/0/0]
7-514-029	Paper Jam Cnt Loc	Fd2Sn:OnCass4Fd	CTL*	[0 to 65535/0/0]
7-514-030	Paper Jam Cnt Loc	Fd2Sn:OffCass3Fd	CTL*	[0 to 65535/0/0]
7-514-031	Paper Jam Cnt Loc	Fd2Sn:OffCass4Fd	CTL*	[0 to 65535/0/0]
7-514-032	Paper Jam Cnt Loc	Fd3Sn:OnCass4Fd2	CTL*	[0 to 65535/0/0]
7-514-033	Paper Jam Cnt Loc	Fd3Sn:OffCass4Fd	CTL*	[0 to 65535/0/0]
7-514-034	Paper Jam Cnt Loc	RegSn:OnCass2Fd	CTL*	[0 to 65535/0/0]
7-514-035	Paper Jam Cnt Loc	RegSn:OnCass3Fd	CTL*	[0 to 65535/0/0]
7-514-036	Paper Jam Cnt Loc	RegSn:OnCass4Fd	CTL*	[0 to 65535/0/0]
7-514-037	Paper Jam Cnt Loc	RegSn:OnMPFFd	CTL*	[0 to 65535/0/0]
7-514-038	Paper Jam Cnt Loc	RegSn:OffCass2Fd	CTL*	[0 to 65535/0/0]
7-514-039	Paper Jam Cnt Loc	RegSn:OffCass3Fd	CTL*	[0 to 65535/0/0]
7-514-040	Paper Jam Cnt Loc	RegSn:OffCass4Fd	CTL*	[0 to 65535/0/0]
7-514-041	Paper Jam Cnt Loc	RegSn:OffMPFFd	CTL*	[0 to 65535/0/0]
7-514-042	Paper Jam Cnt Loc	ExtSn:OnCass1Fd	CTL*	[0 to 65535/0/0]
7-514-043	Paper Jam Cnt Loc	ExtSn:OnCass2Fd	CTL*	[0 to 65535/0/0]
7-514-044	Paper Jam Cnt Loc	ExtSn:OnCass3Fd	CTL*	[0 to 65535/0/0]
7-514-045	Paper Jam Cnt Loc	ExtSn:OnCass4Fd	CTL*	[0 to 65535/0/0]
7-514-046	Paper Jam Cnt Loc	ExtSn:OnDxFd	CTL*	[0 to 65535/0/0]
7-514-047	Paper Jam Cnt Loc	ExtSn:OnMPFFd	CTL*	[0 to 65535/0/0]
7-514-048	Paper Jam Cnt Loc	ExtSn:OffCass1Fd	CTL*	[0 to 65535/0/0]
7-514-049	Paper Jam Cnt Loc	ExtSn:OffCass2Fd	CTL*	[0 to 65535/0/0]
7-514-050	Paper Jam Cnt Loc	ExtSn:OffCass3Fd	CTL*	[0 to 65535/0/0]
7-514-051	Paper Jam Cnt Loc	ExtSn:OffCass4Fd	CTL*	[0 to 65535/0/0]

## 3.SP Mode Tables

SP No.	Large Category	Small Category	ENG or CTL	[Min to Max/Init./Step]
7-514-052	Paper Jam Cnt Loc	ExtSn:OffDxFd	CTL*	[0 to 65535/0/0]
7-514-053	Paper Jam Cnt Loc	ExtSn:OffMPFFd	CTL*	[0 to 65535/0/0]
7-514-054	Paper Jam Cnt Loc	DxTPSn:OnCass1Fd	CTL*	[0 to 65535/0/0]
7-514-055	Paper Jam Cnt Loc	DxTPSn:OnCass2Fd	CTL*	[0 to 65535/0/0]
7-514-056	Paper Jam Cnt Loc	DxTPSn:OnCass3Fd	CTL*	[0 to 65535/0/0]
7-514-057	Paper Jam Cnt Loc	DxTPSn:OnCass4Fd	CTL*	[0 to 65535/0/0]
7-514-058	Paper Jam Cnt Loc	DxTPSn:OnMPFFd	CTL*	[0 to 65535/0/0]
7-514-059	Paper Jam Cnt Loc	DxTPSn:OffCass1Fd	CTL*	[0 to 65535/0/0]
7-514-060	Paper Jam Cnt Loc	DxTPSn:OffCass2Fd	CTL*	[0 to 65535/0/0]
7-514-061	Paper Jam Cnt Loc	DxTPSn:OffCass3Fd	CTL*	[0 to 65535/0/0]
7-514-062	Paper Jam Cnt Loc	DxTPSn:OffCass4Fd	CTL*	[0 to 65535/0/0]
7-514-063	Paper Jam Cnt Loc	DxTPSn:OffMPFFd	CTL*	[0 to 65535/0/0]
7-514-099	Paper Jam Cnt Loc	Tray2:Off2	CTL*	[0 to 65535/0/0]
7-514-100	Paper Jam Cnt Loc	Tray2:RearCvrOpen	CTL*	[0 to 65535/0/0]
7-514-101	Paper Jam Cnt Loc	Tray3:Off	CTL*	[0 to 65535/0/0]
7-514-102	Paper Jam Cnt Loc	Tray3:RearCvrOpen	CTL*	[0 to 65535/0/0]
7-514-103	Paper Jam Cnt Loc	Tray4:Off	CTL*	[0 to 65535/0/0]
7-514-104	Paper Jam Cnt Loc	Tray4:RearCvrOpen	CTL*	[0 to 65535/0/0]
7-516-006	PaperSize Jam Cnt	A5 LEF	CTL*	[0 to 65535/0/0]
7-516-044	PaperSize Jam Cnt	HLT LEF	CTL*	[0 to 65535/0/0]
7-516-133	PaperSize Jam Cnt	A4 SEF	CTL*	[0 to 65535/0/0]
7-516-134	PaperSize Jam Cnt	A5 SEF	CTL*	[0 to 65535/0/0]
7-516-142	PaperSize Jam Cnt	B5 SEF	CTL*	[0 to 65535/0/0]
7-516-164	PaperSize Jam Cnt	LG SEF	CTL*	[0 to 65535/0/0]
7-516-166	PaperSize Jam Cnt	LT SEF	CTL*	[0 to 65535/0/0]
7-516-172	PaperSize Jam Cnt	HLT SEF	CTL*	[0 to 65535/0/0]
7-516-255	PaperSize Jam Cnt	Other	CTL*	[0 to 65535/0/0]
7-520-001	Update Log	Record1	CTL*	[0 to 255/0/1]
7-520-002	Update Log	Record2	CTL*	[0 to 255/0/1]
7-520-003	Update Log	Record3	CTL*	[0 to 255/0/1]
7-520-004	Update Log	Record4	CTL*	[0 to 255/0/1]
7-520-005	Update Log	Record5	CTL*	[0 to 255/0/1]
7-520-006	Update Log	Record6	CTL*	[0 to 255/0/1]
7-520-007	Update Log	Record7	CTL*	[0 to 255/0/1]
7-520-008	Update Log	Record8	CTL*	[0 to 255/0/1]
7-520-009	Update Log	Record9	CTL*	[0 to 255/0/1]
7-520-010	Update Log	Record10	CTL*	[0 to 255/0/1]

### 3.SP Mode Tables

SP No.	Large Category	Small Category	ENG or CTL	[Min to Max/Init./Step]
7-617-001	PM Parts Counter Display	Normal	CTL*	[0 to 9999999/0/0]
7-617-002	PM Parts Counter Display	Df	CTL*	[0 to 9999999/0/0]
7-618-001	PM Parts Counter Reset	Normal	CTL	[0 to 0/0/0]
7-618-002	PM Parts Counter Reset	Df	CTL	[0 to 0/0/0]
7-801-255	Memory/Version/PN		CTL	[0 to 0/0/0]
7-803-001	PM Counter	Paper	CTL*	[0 to 9999999/0/0]
7-804-001	PM Count.Reset	Paper	CTL	[0 to 0/0/0]
7-807-001	Reset-SC/Jam		CTL	[0 to 0/0/0]
7-832-001	Display-Self-Diag		CTL	[0 to 0/0/0]
7-836-001	Resident Memory		CTL	[0 to 0xfffffff/0/0MB]
7-855-001	Coverage Range	Coverage Range 1	CTL*	[1 to 200/5/1%]
7-855-002	Coverage Range	Coverage Range 2	CTL*	[1 to 200/20/1%]
7-901-001	Assert Info.	File Name	CTL*	[0 to 0/0/0]
7-901-002	Assert Info.	Number of Lines	CTL*	[0 to 0/0/0]
7-901-003	Assert Info.	Location	CTL*	[0 to 0/0/0]
7-910-001	ROM No	System	CTL	[0 to 0/0/0]
7-910-002	ROM No	Engine	CTL	[0 to 0/0/0]
7-910-009	ROM No	Bank	CTL	[0 to 0/0/0]
7-910-015	ROM No	Engine(IPU)	CTL	[0 to 0/0/0]
7-910-018	ROM No	NetworkSupport	CTL	[0 to 0/0/0]
7-910-019	ROM No	Bank2	CTL	[0 to 0/0/0]
7-910-022	ROM No	BIOS	CTL	[0 to 0/0/0]
7-910-023	ROM No	HDD Format Option	CTL	[0 to 0/0/0]
7-910-040	ROM No	Bank3	CTL	[0 to 0/0/0]
7-910-150	ROM No	RPCS	CTL	[0 to 0/0/0]
7-910-151	ROM No	PS	CTL	[0 to 0/0/0]
7-910-158	ROM No	PCL	CTL	[0 to 0/0/0]
7-910-159	ROM No	PCLXL	CTL	[0 to 0/0/0]
7-910-162	ROM No	PDF	CTL	[0 to 0/0/0]
7-910-164	ROM No	PictBridge	CTL	[0 to 0/0/0]
7-910-165	ROM No	PJL	CTL	[0 to 0/0/0]
7-910-169	ROM No	XPS	CTL	[0 to 0/0/0]
7-910-180	ROM No	FONT	CTL	[0 to 0/0/0]
7-910-181	ROM No	FONT1	CTL	[0 to 0/0/0]
7-910-182	ROM No	FONT2	CTL	[0 to 0/0/0]
7-910-183	ROM No	FONT3	CTL	[0 to 0/0/0]
7-910-184	ROM No	FONT4	CTL	[0 to 0/0/0]

## 3.SP Mode Tables

SP No.	Large Category	Small Category	ENG or CTL	[Min to Max/Init./Step]
7-910-185	ROM No	FONT5	CTL	[0 to 0/0/0]
7-910-186	ROM No	FONT6	CTL	[0 to 0/0/0]
7-910-187	ROM No	FONT7	CTL	[0 to 0/0/0]
7-910-200	ROM No	Factory	CTL	[0 to 0/0/0]
7-910-202	ROM No	NetworkDocBox	CTL	[0 to 0/0/0]
7-910-204	ROM No	Printer	CTL	[0 to 0/0/0]
7-910-210	ROM No	MIB	CTL	[0 to 0/0/0]
7-910-211	ROM No	Websupport	CTL	[0 to 0/0/0]
7-910-213	ROM No	SDK1	CTL	[0 to 0/0/0]
7-910-214	ROM No	SDK2	CTL	[0 to 0/0/0]
7-910-215	ROM No	SDK3	CTL	[0 to 0/0/0]
7-911-001	Firmware Version	System	CTL	[0 to 0/0/0]
7-911-002	Firmware Version	Engine	CTL	[0 to 0/0/0]
7-911-009	Firmware Version	Bank	CTL	[0 to 0/0/0]
7-911-015	Firmware Version	Engine(IPU)	CTL	[0 to 0/0/0]
7-911-018	Firmware Version	NetworkSupport	CTL	[0 to 0/0/0]
7-911-019	Firmware Version	Bank2	CTL	[0 to 0/0/0]
7-911-022	Firmware Version	BIOS	CTL	[0 to 0/0/0]
7-911-023	Firmware Version	HDD Format Option	CTL	[0 to 0/0/0]
7-911-040	Firmware Version	Bank3	CTL	[0 to 0/0/0]
7-911-150	Firmware Version	RPCS	CTL	[0 to 0/0/0]
7-911-151	Firmware Version	PS	CTL	[0 to 0/0/0]
7-911-158	Firmware Version	PCL	CTL	[0 to 0/0/0]
7-911-159	Firmware Version	PCLXL	CTL	[0 to 0/0/0]
7-911-162	Firmware Version	PDF	CTL	[0 to 0/0/0]
7-911-164	Firmware Version	PictBridge	CTL	[0 to 0/0/0]
7-911-165	Firmware Version	PJL	CTL	[0 to 0/0/0]
7-911-169	Firmware Version	XPS	CTL	[0 to 0/0/0]
7-911-180	Firmware Version	FONT	CTL	[0 to 0/0/0]
7-911-181	Firmware Version	FONT1	CTL	[0 to 0/0/0]
7-911-182	Firmware Version	FONT2	CTL	[0 to 0/0/0]
7-911-183	Firmware Version	FONT3	CTL	[0 to 0/0/0]
7-911-184	Firmware Version	FONT4	CTL	[0 to 0/0/0]
7-911-185	Firmware Version	FONT5	CTL	[0 to 0/0/0]
7-911-186	Firmware Version	FONT6	CTL	[0 to 0/0/0]
7-911-187	Firmware Version	FONT7	CTL	[0 to 0/0/0]
7-911-200	Firmware Version	Factory	CTL	[0 to 0/0/0]

### 3.SP Mode Tables

SP No.	Large Category	Small Category	ENG or CTL	[Min to Max/Init./Step]
7-911-202	Firmware Version	NetworkDocBox	CTL	[0 to 0/0/0]
7-911-204	Firmware Version	Printer	CTL	[0 to 0/0/0]
7-911-210	Firmware Version	MIB	CTL	[0 to 0/0/0]
7-911-211	Firmware Version	Websupport	CTL	[0 to 0/0/0]
7-911-213	Firmware Version	SDK1	CTL	[0 to 0/0/0]
7-911-214	Firmware Version	SDK2	CTL	[0 to 0/0/0]
7-911-215	Firmware Version	SDK3	CTL	[0 to 0/0/0]

## Main SP Tables-8

### SP8-XXX (Data Log2)

SP No.	Large Category	Small Category	ENG or CTL	[Min to Max/Init./Step]
8-001-001	T:Total Jobs		CTL	[0 to 999999999/0/1]
8-004-001	P:Total Jobs		CTL	[0 to 999999999/0/1]
8-061-001	T:FIN Jobs	Sort	CTL	[0 to 999999999/0/1]
8-061-002	T:FIN Jobs	Stack	CTL	[0 to 999999999/0/1]
8-061-003	T:FIN Jobs	Staple	CTL	[0 to 999999999/0/1]
8-061-004	T:FIN Jobs	Booklet	CTL	[0 to 999999999/0/1]
8-061-005	T:FIN Jobs	Z-Fold	CTL	[0 to 999999999/0/1]
8-061-006	T:FIN Jobs	Punch	CTL	[0 to 999999999/0/1]
8-061-007	T:FIN Jobs	Other	CTL	[0 to 999999999/0/1]
8-061-008	T:FIN Jobs	Inside-Fold	CTL	[0 to 999999999/0/1]
8-061-009	T:FIN Jobs	Three-IN-Fold	CTL	[0 to 999999999/0/1]
8-061-010	T:FIN Jobs	Three-OUT-Fold	CTL	[0 to 999999999/0/1]
8-061-011	T:FIN Jobs	Four-Fold	CTL	[0 to 999999999/0/1]
8-061-012	T:FIN Jobs	KANNON-Fold	CTL	[0 to 999999999/0/1]
8-061-013	T:FIN Jobs	Perfect-Bind	CTL	[0 to 999999999/0/1]
8-061-014	T:FIN Jobs	Ring-Bind	CTL	[0 to 999999999/0/1]
8-061-	T:FIN Jobs	3rd Vendor	CTL	[0 to 999999999/0/1]

3.SP Mode Tables

SP No.	Large Category	Small Category	ENG or CTL	[Min to Max/Init./Step]
015				
8-061-016	T:FIN Jobs	TwinLoop-Bind	CTL	[0 to 99999999/0/1]
8-064-001	P:FIN Jobs	Sort	CTL	[0 to 99999999/0/1]
8-064-002	P:FIN Jobs	Stack	CTL	[0 to 99999999/0/1]
8-064-003	P:FIN Jobs	Staple	CTL	[0 to 99999999/0/1]
8-064-004	P:FIN Jobs	Booklet	CTL	[0 to 99999999/0/1]
8-064-005	P:FIN Jobs	Z-Fold	CTL	[0 to 99999999/0/1]
8-064-006	P:FIN Jobs	Punch	CTL	[0 to 99999999/0/1]
8-064-007	P:FIN Jobs	Other	CTL	[0 to 99999999/0/1]
8-064-008	P:FIN Jobs	Inside-Fold	CTL	[0 to 99999999/0/1]
8-064-009	P:FIN Jobs	Three-IN-Fold	CTL	[0 to 99999999/0/1]
8-064-010	P:FIN Jobs	Three-OUT-Fold	CTL	[0 to 99999999/0/1]
8-064-011	P:FIN Jobs	Four-Fold	CTL	[0 to 99999999/0/1]
8-064-012	P:FIN Jobs	KANNON-Fold	CTL	[0 to 99999999/0/1]
8-064-013	P:FIN Jobs	Perfect-Bind	CTL	[0 to 99999999/0/1]
8-064-014	P:FIN Jobs	Ring-Bind	CTL	[0 to 99999999/0/1]
8-064-015	P:FIN Jobs	3rd Vendor	CTL	[0 to 99999999/0/1]
8-064-016	P:FIN Jobs	TwinLoop-Bind	CTL	[0 to 99999999/0/1]
8-067-	O:FIN Jobs	Sort	CTL	[0 to 99999999/0/1]

## 3.SP Mode Tables

SP No.	Large Category	Small Category	ENG or CTL	[Min to Max/Init./Step]
001				
8-067-002	O:FIN Jobs	Stack	CTL	[0 to 99999999/0/1]
8-067-003	O:FIN Jobs	Staple	CTL	[0 to 99999999/0/1]
8-067-004	O:FIN Jobs	Booklet	CTL	[0 to 99999999/0/1]
8-067-005	O:FIN Jobs	Z-Fold	CTL	[0 to 99999999/0/1]
8-067-006	O:FIN Jobs	Punch	CTL	[0 to 99999999/0/1]
8-067-007	O:FIN Jobs	Other	CTL	[0 to 99999999/0/1]
8-067-008	O:FIN Jobs	Inside-Fold	CTL	[0 to 99999999/0/1]
8-067-009	O:FIN Jobs	Three-IN-Fold	CTL	[0 to 99999999/0/1]
8-067-010	O:FIN Jobs	Three-OUT-Fold	CTL	[0 to 99999999/0/1]
8-067-011	O:FIN Jobs	Four-Fold	CTL	[0 to 99999999/0/1]
8-067-012	O:FIN Jobs	KANNON-Fold	CTL	[0 to 99999999/0/1]
8-067-013	O:FIN Jobs	Perfect-Bind	CTL	[0 to 99999999/0/1]
8-067-014	O:FIN Jobs	Ring-Bind	CTL	[0 to 99999999/0/1]
8-067-015	O:FIN Jobs	3rd Vendor	CTL	[0 to 99999999/0/1]
8-067-016	O:FIN Jobs	TwinLoop-Bind	CTL	[0 to 99999999/0/1]
8-071-001	T:Jobs/PGS	1 Page	CTL	[0 to 99999999/0/1]
8-071-002	T:Jobs/PGS	2 Pages	CTL	[0 to 99999999/0/1]
8-071-	T:Jobs/PGS	3 Pages	CTL	[0 to 99999999/0/1]

3.SP Mode Tables

SP No.	Large Category	Small Category	ENG or CTL	[Min to Max/Init./Step]
003				
8-071-004	T:Jobs/PGS	4 Pages	CTL	[0 to 99999999/0/1]
8-071-005	T:Jobs/PGS	5 Pages	CTL	[0 to 99999999/0/1]
8-071-006	T:Jobs/PGS	6~10 Pages	CTL	[0 to 99999999/0/1]
8-071-007	T:Jobs/PGS	11~20 Pages	CTL	[0 to 99999999/0/1]
8-071-008	T:Jobs/PGS	21~50 Pages	CTL	[0 to 99999999/0/1]
8-071-009	T:Jobs/PGS	51~100 Pages	CTL	[0 to 99999999/0/1]
8-071-010	T:Jobs/PGS	101~300 Pages	CTL	[0 to 99999999/0/1]
8-071-011	T:Jobs/PGS	301~500 Pages	CTL	[0 to 99999999/0/1]
8-071-012	T:Jobs/PGS	501~700 Pages	CTL	[0 to 99999999/0/1]
8-071-013	T:Jobs/PGS	701~1000 Pages	CTL	[0 to 99999999/0/1]
8-071-014	T:Jobs/PGS	1001~ Pages	CTL	[0 to 99999999/0/1]
8-074-001	P:Jobs/PGS	1 Page	CTL	[0 to 99999999/0/1]
8-074-002	P:Jobs/PGS	2 Pages	CTL	[0 to 99999999/0/1]
8-074-003	P:Jobs/PGS	3 Pages	CTL	[0 to 99999999/0/1]
8-074-004	P:Jobs/PGS	4 Pages	CTL	[0 to 99999999/0/1]
8-074-005	P:Jobs/PGS	5 Pages	CTL	[0 to 99999999/0/1]
8-074-006	P:Jobs/PGS	6~10 Pages	CTL	[0 to 99999999/0/1]
8-074-	P:Jobs/PGS	11~20 Pages	CTL	[0 to 99999999/0/1]

## 3.SP Mode Tables

SP No.	Large Category	Small Category	ENG or CTL	[Min to Max/Init./Step]
007				
8-074-008	P:Jobs/PGS	21~50 Pages	CTL	[0 to 99999999/0/1]
8-074-009	P:Jobs/PGS	51~100 Pages	CTL	[0 to 99999999/0/1]
8-074-010	P:Jobs/PGS	101~300 Pages	CTL	[0 to 99999999/0/1]
8-074-011	P:Jobs/PGS	301~500 Pages	CTL	[0 to 99999999/0/1]
8-074-012	P:Jobs/PGS	501~700 Pages	CTL	[0 to 99999999/0/1]
8-074-013	P:Jobs/PGS	701~1000 Pages	CTL	[0 to 99999999/0/1]
8-074-014	P:Jobs/PGS	1001~ Pages	CTL	[0 to 99999999/0/1]
8-077-001	O:Jobs/PGS	1 Page	CTL	[0 to 99999999/0/1]
8-077-002	O:Jobs/PGS	2 Pages	CTL	[0 to 99999999/0/1]
8-077-003	O:Jobs/PGS	3 Pages	CTL	[0 to 99999999/0/1]
8-077-004	O:Jobs/PGS	4 Pages	CTL	[0 to 99999999/0/1]
8-077-005	O:Jobs/PGS	5 Pages	CTL	[0 to 99999999/0/1]
8-077-006	O:Jobs/PGS	6~10 Pages	CTL	[0 to 99999999/0/1]
8-077-007	O:Jobs/PGS	11~20 Pages	CTL	[0 to 99999999/0/1]
8-077-008	O:Jobs/PGS	21~50 Pages	CTL	[0 to 99999999/0/1]
8-077-009	O:Jobs/PGS	51~100 Pages	CTL	[0 to 99999999/0/1]
8-077-010	O:Jobs/PGS	101~300 Pages	CTL	[0 to 99999999/0/1]
8-077-	O:Jobs/PGS	301~500 Pages	CTL	[0 to 99999999/0/1]

### 3.SP Mode Tables

SP No.	Large Category	Small Category	ENG or CTL	[Min to Max/Init./Step]
011				
8-077-012	O:Jobs/PGS	501~700 Pages	CTL	[0 to 99999999/0/1]
8-077-013	O:Jobs/PGS	701~1000 Pages	CTL	[0 to 99999999/0/1]
8-077-014	O:Jobs/PGS	1001~ Pages	CTL	[0 to 99999999/0/1]
8-081-001	T:Smart Device	Smart Device	CTL	[0 to 99999999/0/1]
8-084-001	P:Smart Device	Smart Device	CTL	[0 to 99999999/0/1]
8-381-001	T:Total PrtPGS	Field Number	CTL	[0 to 99999999/0/1]
8-384-001	P:Total PrtPGS	Field Number	CTL	[0 to 99999999/0/1]
8-387-001	O:Total PrtPGS	Field Number	CTL	[0 to 99999999/0/1]
8-391-001	LSize PrtPGS	A3/DLT, Larger	CTL*	[0 to 99999999/0/1]
8-391-003	LSize PrtPGS	BannerPaper	CTL*	[0 to 99999999/0/1]
8-411-001	Prints/Duplex		CTL*	[0 to 99999999/0/1]
8-421-001	T:PrtPGS/Dup Comb	Simplex> Duplex	CTL*	[0 to 99999999/0/1]
8-421-004	T:PrtPGS/Dup Comb	Simplex Combine	CTL*	[0 to 99999999/0/1]
8-421-005	T:PrtPGS/Dup Comb	Duplex Combine	CTL*	[0 to 99999999/0/1]
8-421-006	T:PrtPGS/Dup Comb	2in1	CTL*	[0 to 99999999/0/1]
8-421-007	T:PrtPGS/Dup Comb	4in1	CTL*	[0 to 99999999/0/1]
8-421-008	T:PrtPGS/Dup Comb	6in1	CTL*	[0 to 99999999/0/1]
8-421-	T:PrtPGS/Dup Comb	8in1	CTL*	[0 to 99999999/0/1]

## 3.SP Mode Tables

SP No.	Large Category	Small Category	ENG or CTL	[Min to Max/Init./Step]
009				
8-421-010	T:PrtPGS/Dup Comb	9in1	CTL*	[0 to 99999999/0/1]
8-421-011	T:PrtPGS/Dup Comb	16in1	CTL*	[0 to 99999999/0/1]
8-421-012	T:PrtPGS/Dup Comb	Booklet	CTL*	[0 to 99999999/0/1]
8-421-013	T:PrtPGS/Dup Comb	Magazine	CTL*	[0 to 99999999/0/1]
8-421-014	T:PrtPGS/Dup Comb	2in1 + Booklet	CTL*	[0 to 99999999/0/1]
8-421-015	T:PrtPGS/Dup Comb	4in1 + Booklet	CTL*	[0 to 99999999/0/1]
8-421-016	T:PrtPGS/Dup Comb	6in1 + Booklet	CTL*	[0 to 99999999/0/1]
8-421-017	T:PrtPGS/Dup Comb	8in1 + Booklet	CTL*	[0 to 99999999/0/1]
8-421-018	T:PrtPGS/Dup Comb	9in1 + Booklet	CTL*	[0 to 99999999/0/1]
8-421-019	T:PrtPGS/Dup Comb	2in1 + Magazine	CTL*	[0 to 99999999/0/1]
8-421-020	T:PrtPGS/Dup Comb	4in1 + Magazine	CTL*	[0 to 99999999/0/1]
8-421-021	T:PrtPGS/Dup Comb	6in1 + Magazine	CTL*	[0 to 99999999/0/1]
8-421-022	T:PrtPGS/Dup Comb	8in1 + Magazine	CTL*	[0 to 99999999/0/1]
8-421-023	T:PrtPGS/Dup Comb	9in1 + Magazine	CTL*	[0 to 99999999/0/1]
8-421-024	T:PrtPGS/Dup Comb	16in1 + Magazine	CTL*	[0 to 99999999/0/1]
8-424-001	P:PrtPGS/Dup Comb	Simplex> Duplex	CTL*	[0 to 99999999/0/1]
8-424-004	P:PrtPGS/Dup Comb	Simplex Combine	CTL*	[0 to 99999999/0/1]
8-424-	P:PrtPGS/Dup	Duplex Combine	CTL*	[0 to 99999999/0/1]

3.SP Mode Tables

SP No.	Large Category	Small Category	ENG or CTL	[Min to Max/Init./Step]
005	Comb			
8-424-006	P:PrtPGS/Dup Comb	2in1	CTL*	[0 to 99999999/0/1]
8-424-007	P:PrtPGS/Dup Comb	4in1	CTL*	[0 to 99999999/0/1]
8-424-008	P:PrtPGS/Dup Comb	6in1	CTL*	[0 to 99999999/0/1]
8-424-009	P:PrtPGS/Dup Comb	8in1	CTL*	[0 to 99999999/0/1]
8-424-010	P:PrtPGS/Dup Comb	9in1	CTL*	[0 to 99999999/0/1]
8-424-011	P:PrtPGS/Dup Comb	16in1	CTL*	[0 to 99999999/0/1]
8-424-012	P:PrtPGS/Dup Comb	Booklet	CTL*	[0 to 99999999/0/1]
8-424-013	P:PrtPGS/Dup Comb	Magazine	CTL*	[0 to 99999999/0/1]
8-424-014	P:PrtPGS/Dup Comb	2in1 + Booklet	CTL*	[0 to 99999999/0/1]
8-424-015	P:PrtPGS/Dup Comb	4in1 + Booklet	CTL*	[0 to 99999999/0/1]
8-424-016	P:PrtPGS/Dup Comb	6in1 + Booklet	CTL*	[0 to 99999999/0/1]
8-424-017	P:PrtPGS/Dup Comb	8in1 + Booklet	CTL*	[0 to 99999999/0/1]
8-424-018	P:PrtPGS/Dup Comb	9in1 + Booklet	CTL*	[0 to 99999999/0/1]
8-424-019	P:PrtPGS/Dup Comb	2in1 + Magazine	CTL*	[0 to 99999999/0/1]
8-424-020	P:PrtPGS/Dup Comb	4in1 + Magazine	CTL*	[0 to 99999999/0/1]
8-424-021	P:PrtPGS/Dup Comb	6in1 + Magazine	CTL*	[0 to 99999999/0/1]
8-424-022	P:PrtPGS/Dup Comb	8in1 + Magazine	CTL*	[0 to 99999999/0/1]
8-424-	P:PrtPGS/Dup	9in1 + Magazine	CTL*	[0 to 99999999/0/1]

## 3.SP Mode Tables

SP No.	Large Category	Small Category	ENG or CTL	[Min to Max/Init./Step]
023	Comb			
8-424-024	P:PrtPGS/Dup Comb	16in1 + Magazine	CTL*	[0 to 99999999/0/1]
8-427-001	O:PrtPGS/Dup Comb	Simplex> Duplex	CTL*	[0 to 99999999/0/1]
8-427-004	O:PrtPGS/Dup Comb	Simplex Combine	CTL*	[0 to 99999999/0/1]
8-427-005	O:PrtPGS/Dup Comb	Duplex Combine	CTL*	[0 to 99999999/0/1]
8-427-006	O:PrtPGS/Dup Comb	2in1	CTL*	[0 to 99999999/0/1]
8-427-007	O:PrtPGS/Dup Comb	4in1	CTL*	[0 to 99999999/0/1]
8-427-008	O:PrtPGS/Dup Comb	6in1	CTL*	[0 to 99999999/0/1]
8-427-009	O:PrtPGS/Dup Comb	8in1	CTL*	[0 to 99999999/0/1]
8-427-010	O:PrtPGS/Dup Comb	9in1	CTL*	[0 to 99999999/0/1]
8-427-011	O:PrtPGS/Dup Comb	16in1	CTL*	[0 to 99999999/0/1]
8-427-012	O:PrtPGS/Dup Comb	Booklet	CTL*	[0 to 99999999/0/1]
8-427-013	O:PrtPGS/Dup Comb	Magazine	CTL*	[0 to 99999999/0/1]
8-427-014	O:PrtPGS/Dup Comb	2in1 + Booklet	CTL*	[0 to 99999999/0/1]
8-427-015	O:PrtPGS/Dup Comb	4in1 + Booklet	CTL*	[0 to 99999999/0/1]
8-427-016	O:PrtPGS/Dup Comb	6in1 + Booklet	CTL*	[0 to 99999999/0/1]
8-427-017	O:PrtPGS/Dup Comb	8in1 + Booklet	CTL*	[0 to 99999999/0/1]
8-427-018	O:PrtPGS/Dup Comb	9in1 + Booklet	CTL*	[0 to 99999999/0/1]
8-427-	O:PrtPGS/Dup	2in1 + Magazine	CTL*	[0 to 99999999/0/1]

### 3.SP Mode Tables

SP No.	Large Category	Small Category	ENG or CTL	[Min to Max/Init./Step]
019	Comb			
8-427-020	O:PrtPGS/Dup Comb	4in1 + Magazine	CTL*	[0 to 99999999/0/1]
8-427-021	O:PrtPGS/Dup Comb	6in1 + Magazine	CTL*	[0 to 99999999/0/1]
8-427-022	O:PrtPGS/Dup Comb	8in1 + Magazine	CTL*	[0 to 99999999/0/1]
8-427-023	O:PrtPGS/Dup Comb	9in1 + Magazine	CTL*	[0 to 99999999/0/1]
8-427-024	O:PrtPGS/Dup Comb	16in1 + Magazine	CTL*	[0 to 99999999/0/1]
8-431-001	T:PrtPGS/ImgEdt	Cover/Slip Sheet	CTL*	[0 to 99999999/0/1]
8-431-002	T:PrtPGS/ImgEdt	Series/Book	CTL*	[0 to 99999999/0/1]
8-431-003	T:PrtPGS/ImgEdt	User Stamp	CTL*	[0 to 99999999/0/1]
8-434-001	P:PrtPGS/ImgEdt	Cover/Slip Sheet	CTL*	[0 to 99999999/0/1]
8-434-002	P:PrtPGS/ImgEdt	Series/Book	CTL*	[0 to 99999999/0/1]
8-434-003	P:PrtPGS/ImgEdt	User Stamp	CTL*	[0 to 99999999/0/1]
8-437-001	O:PrtPGS/ImgEdt	Cover/Slip Sheet	CTL*	[0 to 99999999/0/1]
8-437-002	O:PrtPGS/ImgEdt	Series/Book	CTL*	[0 to 99999999/0/1]
8-437-003	O:PrtPGS/ImgEdt	User Stamp	CTL*	[0 to 99999999/0/1]
8-441-001	T:PrtPGS/Ppr Size	A3	CTL*	[0 to 99999999/0/1]
8-441-002	T:PrtPGS/Ppr Size	A4	CTL*	[0 to 99999999/0/1]
8-441-003	T:PrtPGS/Ppr Size	A5	CTL*	[0 to 99999999/0/1]
8-441-	T:PrtPGS/Ppr Size	B4	CTL*	[0 to 99999999/0/1]

## 3.SP Mode Tables

SP No.	Large Category	Small Category	ENG or CTL	[Min to Max/Init./Step]
004				
8-441-005	T:PrtPGS/Ppr Size	B5	CTL*	[0 to 99999999/0/1]
8-441-006	T:PrtPGS/Ppr Size	DLT	CTL*	[0 to 99999999/0/1]
8-441-007	T:PrtPGS/Ppr Size	LG	CTL*	[0 to 99999999/0/1]
8-441-008	T:PrtPGS/Ppr Size	LT	CTL*	[0 to 99999999/0/1]
8-441-009	T:PrtPGS/Ppr Size	HLT	CTL*	[0 to 99999999/0/1]
8-441-010	T:PrtPGS/Ppr Size	Full Bleed	CTL*	[0 to 99999999/0/1]
8-441-254	T:PrtPGS/Ppr Size	Other (Standard)	CTL*	[0 to 99999999/0/1]
8-441-255	T:PrtPGS/Ppr Size	Other (Custom)	CTL*	[0 to 99999999/0/1]
8-444-001	P:PrtPGS/Ppr Size	A3	CTL*	[0 to 99999999/0/1]
8-444-002	P:PrtPGS/Ppr Size	A4	CTL*	[0 to 99999999/0/1]
8-444-003	P:PrtPGS/Ppr Size	A5	CTL*	[0 to 99999999/0/1]
8-444-004	P:PrtPGS/Ppr Size	B4	CTL*	[0 to 99999999/0/1]
8-444-005	P:PrtPGS/Ppr Size	B5	CTL*	[0 to 99999999/0/1]
8-444-006	P:PrtPGS/Ppr Size	DLT	CTL*	[0 to 99999999/0/1]
8-444-007	P:PrtPGS/Ppr Size	LG	CTL*	[0 to 99999999/0/1]
8-444-008	P:PrtPGS/Ppr Size	LT	CTL*	[0 to 99999999/0/1]
8-444-009	P:PrtPGS/Ppr Size	HLT	CTL*	[0 to 99999999/0/1]
8-444-	P:PrtPGS/Ppr Size	Full Bleed	CTL*	[0 to 99999999/0/1]

### 3.SP Mode Tables

SP No.	Large Category	Small Category	ENG or CTL	[Min to Max/Init./Step]
010				
8-444-254	P:PrtPGS/Ppr Size	Other (Standard)	CTL*	[0 to 99999999/0/1]
8-444-255	P:PrtPGS/Ppr Size	Other (Custom)	CTL*	[0 to 99999999/0/1]
8-447-001	O:PrtPGS/Ppr Size	A3	CTL*	[0 to 99999999/0/1]
8-447-002	O:PrtPGS/Ppr Size	A4	CTL*	[0 to 99999999/0/1]
8-447-003	O:PrtPGS/Ppr Size	A5	CTL*	[0 to 99999999/0/1]
8-447-004	O:PrtPGS/Ppr Size	B4	CTL*	[0 to 99999999/0/1]
8-447-005	O:PrtPGS/Ppr Size	B5	CTL*	[0 to 99999999/0/1]
8-447-006	O:PrtPGS/Ppr Size	DLT	CTL*	[0 to 99999999/0/1]
8-447-007	O:PrtPGS/Ppr Size	LG	CTL*	[0 to 99999999/0/1]
8-447-008	O:PrtPGS/Ppr Size	LT	CTL*	[0 to 99999999/0/1]
8-447-009	O:PrtPGS/Ppr Size	HLT	CTL*	[0 to 99999999/0/1]
8-447-010	O:PrtPGS/Ppr Size	Full Bleed	CTL*	[0 to 99999999/0/1]
8-447-254	O:PrtPGS/Ppr Size	Other (Standard)	CTL*	[0 to 99999999/0/1]
8-447-255	O:PrtPGS/Ppr Size	Other (Custom)	CTL*	[0 to 99999999/0/1]
8-451-001	PrtPGS/Ppr Tray	Bypass Tray	CTL*	[0 to 99999999/0/1]
8-451-002	PrtPGS/Ppr Tray	Tray 1	CTL*	[0 to 99999999/0/1]
8-451-003	PrtPGS/Ppr Tray	Tray 2	CTL*	[0 to 99999999/0/1]
8-451-	PrtPGS/Ppr Tray	Tray 3	CTL*	[0 to 99999999/0/1]

## 3.SP Mode Tables

SP No.	Large Category	Small Category	ENG or CTL	[Min to Max/Init./Step]
004				
8-451-005	PrtPGS/Ppr Tray	Tray 4	CTL*	[0 to 99999999/0/1]
8-451-006	PrtPGS/Ppr Tray	Tray 5	CTL*	[0 to 99999999/0/1]
8-451-007	PrtPGS/Ppr Tray	Tray 6	CTL*	[0 to 99999999/0/1]
8-451-008	PrtPGS/Ppr Tray	Tray 7	CTL*	[0 to 99999999/0/1]
8-451-009	PrtPGS/Ppr Tray	Tray 8	CTL*	[0 to 99999999/0/1]
8-451-010	PrtPGS/Ppr Tray	Tray 9	CTL*	[0 to 99999999/0/1]
8-451-011	PrtPGS/Ppr Tray	Tray 10	CTL*	[0 to 99999999/0/1]
8-451-012	PrtPGS/Ppr Tray	Tray 11	CTL*	[0 to 99999999/0/1]
8-451-013	PrtPGS/Ppr Tray	Tray 12	CTL*	[0 to 99999999/0/1]
8-451-014	PrtPGS/Ppr Tray	Tray 13	CTL*	[0 to 99999999/0/1]
8-451-015	PrtPGS/Ppr Tray	Tray 14	CTL*	[0 to 99999999/0/1]
8-451-016	PrtPGS/Ppr Tray	Tray 15	CTL*	[0 to 99999999/0/1]
8-451-101	PrtPGS/Ppr Tray	LC Inserter	CTL*	[0 to 99999999/0/1]
8-451-102	PrtPGS/Ppr Tray	3rd Vendor	CTL*	[0 to 99999999/0/1]
8-461-001	T:PrtPGS/Ppr Type	Normal	CTL*	[0 to 99999999/0/1]
8-461-002	T:PrtPGS/Ppr Type	Recycled	CTL*	[0 to 99999999/0/1]
8-461-003	T:PrtPGS/Ppr Type	Special	CTL*	[0 to 99999999/0/1]
8-461-	T:PrtPGS/Ppr Type	Thick	CTL*	[0 to 99999999/0/1]

### 3.SP Mode Tables

SP No.	Large Category	Small Category	ENG or CTL	[Min to Max/Init./Step]
004				
8-461-005	T:PrtPGS/Ppr Type	Normal (Back)	CTL*	[0 to 99999999/0/1]
8-461-006	T:PrtPGS/Ppr Type	Thick (Back)	CTL*	[0 to 99999999/0/1]
8-461-007	T:PrtPGS/Ppr Type	OHP	CTL*	[0 to 99999999/0/1]
8-461-008	T:PrtPGS/Ppr Type	Other	CTL*	[0 to 99999999/0/1]
8-464-001	P:PrtPGS/Ppr Type	Normal	CTL*	[0 to 99999999/0/1]
8-464-002	P:PrtPGS/Ppr Type	Recycled	CTL*	[0 to 99999999/0/1]
8-464-003	P:PrtPGS/Ppr Type	Special	CTL*	[0 to 99999999/0/1]
8-464-004	P:PrtPGS/Ppr Type	Thick	CTL*	[0 to 99999999/0/1]
8-464-005	P:PrtPGS/Ppr Type	Normal (Back)	CTL*	[0 to 99999999/0/1]
8-464-006	P:PrtPGS/Ppr Type	Thick (Back)	CTL*	[0 to 99999999/0/1]
8-464-007	P:PrtPGS/Ppr Type	OHP	CTL*	[0 to 99999999/0/1]
8-464-008	P:PrtPGS/Ppr Type	Other	CTL*	[0 to 99999999/0/1]
8-471-001	PrtPGS/Mag	~49%	CTL*	[0 to 99999999/0/1]
8-471-002	PrtPGS/Mag	50%~99%	CTL*	[0 to 99999999/0/1]
8-471-003	PrtPGS/Mag	100%	CTL*	[0 to 99999999/0/1]
8-471-004	PrtPGS/Mag	101%~200%	CTL*	[0 to 99999999/0/1]
8-471-005	PrtPGS/Mag	201% ~	CTL*	[0 to 99999999/0/1]
8-481-	T:PrtPGS/TonSave		CTL*	[0 to 99999999/0/1]

## 3.SP Mode Tables

SP No.	Large Category	Small Category	ENG or CTL	[Min to Max/Init./Step]
001				
8-484-001	P:PrtPGS/TonSave		CTL*	[0 to 99999999/0/1]
8-501-001	T:PrtPGS/Col Mode	B/W	CTL*	[0 to 99999999/0/1]
8-501-002	T:PrtPGS/Col Mode	Mono Color	CTL*	[0 to 99999999/0/1]
8-501-003	T:PrtPGS/Col Mode	Full Color	CTL*	[0 to 99999999/0/1]
8-501-004	T:PrtPGS/Col Mode	Single Color	CTL*	[0 to 99999999/0/1]
8-501-005	T:PrtPGS/Col Mode	Two Color	CTL*	[0 to 99999999/0/1]
8-501-051	T:PrtPGS/Col Mode	B/W(Banner)	CTL*	[0 to 99999999/0/1]
8-501-052	T:PrtPGS/Col Mode	Full Color(Banner)	CTL*	[0 to 99999999/0/1]
8-501-053	T:PrtPGS/Col Mode	Single Color(Banner)	CTL*	[0 to 99999999/0/1]
8-501-054	T:PrtPGS/Col Mode	Two Color(Banner)	CTL*	[0 to 99999999/0/1]
8-504-001	P:PrtPGS/Col Mode	B/W	CTL*	[0 to 99999999/0/1]
8-504-002	P:PrtPGS/Col Mode	Mono Color	CTL*	[0 to 99999999/0/1]
8-504-003	P:PrtPGS/Col Mode	Full Color	CTL*	[0 to 99999999/0/1]
8-504-004	P:PrtPGS/Col Mode	Single Color	CTL*	[0 to 99999999/0/1]
8-504-005	P:PrtPGS/Col Mode	Two Color	CTL*	[0 to 99999999/0/1]
8-504-051	P:PrtPGS/Col Mode	B/W(Banner)	CTL*	[0 to 99999999/0/1]
8-504-052	P:PrtPGS/Col Mode	Full Color(Banner)	CTL*	[0 to 99999999/0/1]
8-504-	P:PrtPGS/Col Mode	Single Color(Banner)	CTL*	[0 to 99999999/0/1]

### 3.SP Mode Tables

SP No.	Large Category	Small Category	ENG or CTL	[Min to Max/Init./Step]
053				
8-504-054	P:PrtPGS/Col Mode	Two Color(Banner)	CTL*	[0 to 99999999/0/1]
8-507-001	O:PrtPGS/Col Mode	B/W	CTL*	[0 to 99999999/0/1]
8-507-002	O:PrtPGS/Col Mode	Mono Color	CTL*	[0 to 99999999/0/1]
8-507-003	O:PrtPGS/Col Mode	Full Color	CTL*	[0 to 99999999/0/1]
8-507-004	O:PrtPGS/Col Mode	Single Color	CTL*	[0 to 99999999/0/1]
8-507-005	O:PrtPGS/Col Mode	Two Color	CTL*	[0 to 99999999/0/1]
8-507-051	O:PrtPGS/Col Mode	B/W(Banner)	CTL*	[0 to 99999999/0/1]
8-507-052	O:PrtPGS/Col Mode	Full Color(Banner)	CTL*	[0 to 99999999/0/1]
8-507-053	O:PrtPGS/Col Mode	Single Color(Banner)	CTL*	[0 to 99999999/0/1]
8-507-054	O:PrtPGS/Col Mode	Two Color(Banner)	CTL*	[0 to 99999999/0/1]
8-511-001	T:PrtPGS/Emul	RPCS	CTL*	[0 to 99999999/0/1]
8-511-002	T:PrtPGS/Emul	RPDL	CTL*	[0 to 99999999/0/1]
8-511-003	T:PrtPGS/Emul	PS3	CTL*	[0 to 99999999/0/1]
8-511-004	T:PrtPGS/Emul	R98	CTL*	[0 to 99999999/0/1]
8-511-005	T:PrtPGS/Emul	R16	CTL*	[0 to 99999999/0/1]
8-511-006	T:PrtPGS/Emul	GL/GL2	CTL*	[0 to 99999999/0/1]
8-511-007	T:PrtPGS/Emul	R55	CTL*	[0 to 99999999/0/1]
8-511-	T:PrtPGS/Emul	RTIFF	CTL*	[0 to 99999999/0/1]

## 3.SP Mode Tables

SP No.	Large Category	Small Category	ENG or CTL	[Min to Max/Init./Step]
008				
8-511-009	T:PrtPGS/Emul	PDF	CTL*	[0 to 99999999/0/1]
8-511-010	T:PrtPGS/Emul	PCL5e/5c	CTL*	[0 to 99999999/0/1]
8-511-011	T:PrtPGS/Emul	PCL XL	CTL*	[0 to 99999999/0/1]
8-511-012	T:PrtPGS/Emul	IPDL-C	CTL*	[0 to 99999999/0/1]
8-511-013	T:PrtPGS/Emul	BM-Links	CTL*	[0 to 99999999/0/1]
8-511-014	T:PrtPGS/Emul	Other	CTL*	[0 to 99999999/0/1]
8-511-015	T:PrtPGS/Emul	IPDS	CTL*	[0 to 99999999/0/1]
8-511-016	T:PrtPGS/Emul	XPS	CTL*	[0 to 99999999/0/1]
8-511-017	T:PrtPGS/Emul	IRIPS PS	CTL*	[0 to 99999999/0/1]
8-511-018	T:PrtPGS/Emul	IRIPS PDF	CTL*	[0 to 99999999/0/1]
8-511-019	T:PrtPGS/Emul	PictBridge	CTL*	[0 to 99999999/0/1]
8-511-020	T:PrtPGS/Emul	MediaPrintTIFF	CTL*	[0 to 99999999/0/1]
8-511-021	T:PrtPGS/Emul	MediaPrintJPEG	CTL*	[0 to 99999999/0/1]
8-514-001	P:PrtPGS/Emul	RPCS	CTL*	[0 to 99999999/0/1]
8-514-002	P:PrtPGS/Emul	RPDL	CTL*	[0 to 99999999/0/1]
8-514-003	P:PrtPGS/Emul	PS3	CTL*	[0 to 99999999/0/1]
8-514-004	P:PrtPGS/Emul	R98	CTL*	[0 to 99999999/0/1]
8-514-	P:PrtPGS/Emul	R16	CTL*	[0 to 99999999/0/1]

### 3.SP Mode Tables

SP No.	Large Category	Small Category	ENG or CTL	[Min to Max/Init./Step]
005				
8-514-006	P:PrtPGS/Emul	GL/GL2	CTL*	[0 to 99999999/0/1]
8-514-007	P:PrtPGS/Emul	R55	CTL*	[0 to 99999999/0/1]
8-514-008	P:PrtPGS/Emul	RTIFF	CTL*	[0 to 99999999/0/1]
8-514-009	P:PrtPGS/Emul	PDF	CTL*	[0 to 99999999/0/1]
8-514-010	P:PrtPGS/Emul	PCL5e/5c	CTL*	[0 to 99999999/0/1]
8-514-011	P:PrtPGS/Emul	PCL XL	CTL*	[0 to 99999999/0/1]
8-514-012	P:PrtPGS/Emul	IPDL-C	CTL*	[0 to 99999999/0/1]
8-514-013	P:PrtPGS/Emul	BM-Links	CTL*	[0 to 99999999/0/1]
8-514-014	P:PrtPGS/Emul	Other	CTL*	[0 to 99999999/0/1]
8-514-015	P:PrtPGS/Emul	IPDS	CTL*	[0 to 99999999/0/1]
8-514-016	P:PrtPGS/Emul	XPS	CTL*	[0 to 99999999/0/1]
8-514-017	P:PrtPGS/Emul	IRIPS PS	CTL*	[0 to 99999999/0/1]
8-514-018	P:PrtPGS/Emul	IRIPS PDF	CTL*	[0 to 99999999/0/1]
8-514-019	P:PrtPGS/Emul	PictBridge	CTL*	[0 to 99999999/0/1]
8-514-020	P:PrtPGS/Emul	MediaPrintTIFF	CTL*	[0 to 99999999/0/1]
8-514-021	P:PrtPGS/Emul	MediaPrintJPEG	CTL*	[0 to 99999999/0/1]
8-521-001	T:PrtPGS/FIN	Sort	CTL*	[0 to 99999999/0/1]
8-521-	T:PrtPGS/FIN	Stack	CTL*	[0 to 99999999/0/1]

## 3.SP Mode Tables

SP No.	Large Category	Small Category	ENG or CTL	[Min to Max/Init./Step]
002				
8-521-003	T:PrtPGS/FIN	Staple	CTL*	[0 to 99999999/0/1]
8-521-004	T:PrtPGS/FIN	Booklet	CTL*	[0 to 99999999/0/1]
8-521-005	T:PrtPGS/FIN	Z-Fold	CTL*	[0 to 99999999/0/1]
8-521-006	T:PrtPGS/FIN	Punch	CTL*	[0 to 99999999/0/1]
8-521-007	T:PrtPGS/FIN	Other	CTL*	[0 to 99999999/0/1]
8-521-008	T:PrtPGS/FIN	Inside-Fold	CTL*	[0 to 99999999/0/1]
8-521-009	T:PrtPGS/FIN	Three-IN-Fold	CTL*	[0 to 99999999/0/1]
8-521-010	T:PrtPGS/FIN	Three-OUT-Fold	CTL*	[0 to 99999999/0/1]
8-521-011	T:PrtPGS/FIN	Four-Fold	CTL*	[0 to 99999999/0/1]
8-521-012	T:PrtPGS/FIN	KANNON-Fold	CTL*	[0 to 99999999/0/1]
8-521-013	T:PrtPGS/FIN	Perfect-Bind	CTL*	[0 to 99999999/0/1]
8-521-014	T:PrtPGS/FIN	Ring-Bind	CTL*	[0 to 99999999/0/1]
8-521-015	T:PrtPGS/FIN	3rd Vendor	CTL*	[0 to 99999999/0/1]
8-521-016	T:PrtPGS/FIN	TwinLoop-Bind	CTL*	[0 to 99999999/0/1]
8-524-001	P:PrtPGS/FIN	Sort	CTL*	[0 to 99999999/0/1]
8-524-002	P:PrtPGS/FIN	Stack	CTL*	[0 to 99999999/0/1]
8-524-003	P:PrtPGS/FIN	Staple	CTL*	[0 to 99999999/0/1]
8-524-	P:PrtPGS/FIN	Booklet	CTL*	[0 to 99999999/0/1]

3.SP Mode Tables

SP No.	Large Category	Small Category	ENG or CTL	[Min to Max/Init./Step]
004				
8-524-005	P:PrtPGS/FIN	Z-Fold	CTL*	[0 to 99999999/0/1]
8-524-006	P:PrtPGS/FIN	Punch	CTL*	[0 to 99999999/0/1]
8-524-007	P:PrtPGS/FIN	Other	CTL*	[0 to 99999999/0/1]
8-524-008	P:PrtPGS/FIN	Inside-Fold	CTL*	[0 to 99999999/0/1]
8-524-009	P:PrtPGS/FIN	Three-IN-Fold	CTL*	[0 to 99999999/0/1]
8-524-010	P:PrtPGS/FIN	Three-OUT-Fold	CTL*	[0 to 99999999/0/1]
8-524-011	P:PrtPGS/FIN	Four-Fold	CTL*	[0 to 99999999/0/1]
8-524-012	P:PrtPGS/FIN	KANNON-Fold	CTL*	[0 to 99999999/0/1]
8-524-013	P:PrtPGS/FIN	Perfect-Bind	CTL*	[0 to 99999999/0/1]
8-524-014	P:PrtPGS/FIN	Ring-Bind	CTL*	[0 to 99999999/0/1]
8-524-015	P:PrtPGS/FIN	3rd Vendor	CTL*	[0 to 99999999/0/1]
8-524-016	P:PrtPGS/FIN	TwinLoop-Bind	CTL*	[0 to 99999999/0/1]
8-531-001	Staple	Staples	CTL*	[0 to 99999999/0/1]
8-531-002	Staple	Stapless	CTL*	[0 to 99999999/0/1]
8-551-001	T:FIN Books	Perfect-Bind	CTL*	[0 to 99999999/0/1]
8-551-002	T:FIN Books	Ring-Bind	CTL*	[0 to 99999999/0/1]
8-551-003	T:FIN Books	TwinLoop-Bind	CTL*	[0 to 99999999/0/1]
8-554-	P:FIN Books	Perfect-Bind	CTL*	[0 to 99999999/0/1]

## 3.SP Mode Tables

SP No.	Large Category	Small Category	ENG or CTL	[Min to Max/Init./Step]
001				
8-554-002	P:FIN Books	Ring-Bind	CTL*	[0 to 99999999/0/1]
8-554-003	P:FIN Books	TwinLoop-Bind	CTL*	[0 to 99999999/0/1]
8-561-001	T:A Sheet Of Paper	Total: Over A3/DLT	CTL*	[0 to 99999999/0/1]
8-561-002	T:A Sheet Of Paper	Total: Under A3/DLT	CTL*	[0 to 99999999/0/1]
8-561-003	T:A Sheet Of Paper	Duplex: Over A3/DLT	CTL*	[0 to 99999999/0/1]
8-561-004	T:A Sheet Of Paper	Duplex: Under A3/DLT	CTL*	[0 to 99999999/0/1]
8-564-001	P:A Sheet Of Paper	Total: Over A3/DLT	CTL*	[0 to 99999999/0/1]
8-564-002	P:A Sheet Of Paper	Total: Under A3/DLT	CTL*	[0 to 99999999/0/1]
8-564-003	P:A Sheet Of Paper	Duplex: Over A3/DLT	CTL*	[0 to 99999999/0/1]
8-564-004	P:A Sheet Of Paper	Duplex: Under A3/DLT	CTL*	[0 to 99999999/0/1]
8-567-001	O:A Sheet Of Paper	Total: Over A3/DLT	CTL*	[0 to 99999999/0/1]
8-567-002	O:A Sheet Of Paper	Total: Under A3/DLT	CTL*	[0 to 99999999/0/1]
8-567-003	O:A Sheet Of Paper	Duplex: Over A3/DLT	CTL*	[0 to 99999999/0/1]
8-567-004	O:A Sheet Of Paper	Duplex: Under A3/DLT	CTL*	[0 to 99999999/0/1]
8-581-001	T:Counter	Total	CTL*	[0 to 99999999/0/1]
8-581-002	T:Counter	Total: Full Color	CTL*	[0 to 99999999/0/1]
8-581-003	T:Counter	B&W/Single Color	CTL*	[0 to 99999999/0/1]
8-581-004	T:Counter	Development: CMY	CTL*	[0 to 99999999/0/1]

### 3.SP Mode Tables

SP No.	Large Category	Small Category	ENG or CTL	[Min to Max/Init./Step]
004				
8-581-005	T:Counter	Development: K	CTL*	[0 to 99999999/0/1]
8-581-008	T:Counter	Print: Color	CTL*	[0 to 99999999/0/1]
8-581-009	T:Counter	Print: B/W	CTL*	[0 to 99999999/0/1]
8-581-010	T:Counter	Total: Color	CTL*	[0 to 99999999/0/1]
8-581-011	T:Counter	Total: B/W	CTL*	[0 to 99999999/0/1]
8-581-012	T:Counter	Full Color: A3	CTL*	[0 to 99999999/0/1]
8-581-013	T:Counter	Full Color: -B4	CTL*	[0 to 99999999/0/1]
8-581-014	T:Counter	Full Color Print	CTL*	[0 to 99999999/0/1]
8-581-015	T:Counter	Mono Color Print	CTL*	[0 to 99999999/0/1]
8-581-016	T:Counter	Full Color GPC	CTL*	[0 to 99999999/0/1]
8-581-017	T:Counter	Twin Mode Print	CTL*	[0 to 99999999/0/1]
8-581-018	T:Counter	Full Color Print(Twin)	CTL*	[0 to 99999999/0/1]
8-581-019	T:Counter	Mono Color Print(Twin)	CTL*	[0 to 99999999/0/1]
8-581-020	T:Counter	Full Color Total(CV)	CTL*	[0 to 99999999/0/1]
8-581-021	T:Counter	Mono Color Total(CV)	CTL*	[0 to 99999999/0/1]
8-581-022	T:Counter	Full Color Print(CV)	CTL*	[0 to 99999999/0/1]
8-581-023	T:Counter	Eco Color Print(FC)	CTL*	[0 to 99999999/0/1]
8-581-	T:Counter	Eco Color Print(Bk)	CTL*	[0 to 99999999/0/1]

## 3.SP Mode Tables

SP No.	Large Category	Small Category	ENG or CTL	[Min to Max/Init./Step]
024				
8-581-025	T:Counter	Total: Color(Eco Bk)	CTL*	[0 to 99999999/0/1]
8-581-026	T:Counter	Total: B/W(Eco Bk)	CTL*	[0 to 99999999/0/1]
8-581-027	T:Counter	Total: Color(Eco FC)	CTL*	[0 to 99999999/0/1]
8-581-028	T:Counter	Development: CMY(A3)	CTL*	[0 to 99999999/0/1]
8-581-029	T:Counter	Development: K(A3)	CTL*	[0 to 99999999/0/1]
8-581-030	T:Counter	Total: Color(A3)	CTL*	[0 to 99999999/0/1]
8-581-031	T:Counter	Total: B/W(A3)	CTL*	[0 to 99999999/0/1]
8-584-001	P:Counter	B/W	CTL*	[0 to 99999999/0/1]
8-584-002	P:Counter	Mono Color	CTL*	[0 to 99999999/0/1]
8-584-003	P:Counter	Full Color	CTL*	[0 to 99999999/0/1]
8-584-004	P:Counter	Single Color	CTL*	[0 to 99999999/0/1]
8-584-005	P:Counter	Two Color	CTL*	[0 to 99999999/0/1]
8-591-001	O:Counter	A3/DLT	CTL*	[0 to 99999999/0/1]
8-591-002	O:Counter	Duplex	CTL*	[0 to 99999999/0/1]
8-591-005	O:Counter	Banner	CTL*	[0 to 99999999/0/1]
8-601-001	T:CvgCounter	Cvg: BW %	CTL*	[0 to 2147483647/0/1%]
8-601-002	T:CvgCounter	Cvg: FC %	CTL*	[0 to 2147483647/0/1%]
8-601-	T:CvgCounter	Cvg: BW Pages	CTL*	[0 to 99999999/0/1]

3.SP Mode Tables

SP No.	Large Category	Small Category	ENG or CTL	[Min to Max/Init./Step]
011				
8-601-012	T:CvgCounter	Cvg: FC Pages	CTL*	[0 to 99999999/0/1]
8-601-021	T:CvgCounter	CvgCounter 1	CTL*	[0 to 99999999/0/1]
8-601-022	T:CvgCounter	CvgCounter 2	CTL*	[0 to 99999999/0/1]
8-601-023	T:CvgCounter	CvgCounter 3	CTL*	[0 to 99999999/0/1]
8-601-031	CvgCounter	CvgCounter 1(YMC)	CTL*	[0 to 99999999/0/1]
8-601-032	CvgCounter	CvgCounter 2(YMC)	CTL*	[0 to 99999999/0/1]
8-601-033	CvgCounter	CvgCounter 3(YMC)	CTL*	[0 to 99999999/0/1]
8-604-001	P:CvgCounter	Cvg: B/W %	CTL*	[0 to 2147483647/0/1%]
8-604-002	P:CvgCounter	Cvg: Single Color %	CTL*	[0 to 2147483647/0/1%]
8-604-003	P:CvgCounter	Cvg: Two Color %	CTL*	[0 to 2147483647/0/1%]
8-604-004	P:CvgCounter	Cvg: Full Color %	CTL*	[0 to 2147483647/0/1%]
8-617-001	SDK Apli Counter	SDK-1	CTL*	[0 to 99999999/0/1]
8-617-002	SDK Apli Counter	SDK-2	CTL*	[0 to 99999999/0/1]
8-617-003	SDK Apli Counter	SDK-3	CTL*	[0 to 99999999/0/1]
8-617-004	SDK Apli Counter	SDK-4	CTL*	[0 to 99999999/0/1]
8-617-005	SDK Apli Counter	SDK-5	CTL*	[0 to 99999999/0/1]
8-617-006	SDK Apli Counter	SDK-6	CTL*	[0 to 99999999/0/1]
8-617-007	SDK Apli Counter	SDK-7	CTL*	[0 to 99999999/0/1]

## 3.SP Mode Tables

SP No.	Large Category	Small Category	ENG or CTL	[Min to Max/Init./Step]
007				
8-617-008	SDK Apli Counter	SDK-8	CTL*	[0 to 99999999/0/1]
8-617-009	SDK Apli Counter	SDK-9	CTL*	[0 to 99999999/0/1]
8-617-010	SDK Apli Counter	SDK-10	CTL*	[0 to 99999999/0/1]
8-617-011	SDK Apli Counter	SDK-11	CTL*	[0 to 99999999/0/1]
8-617-012	SDK Apli Counter	SDK-12	CTL*	[0 to 99999999/0/1]
8-621-001	Func Use Counter	Function-001	CTL*	[0 to 99999999/0/1]
8-621-002	Func Use Counter	Function-002	CTL*	[0 to 99999999/0/1]
8-621-003	Func Use Counter	Function-003	CTL*	[0 to 99999999/0/1]
8-621-004	Func Use Counter	Function-004	CTL*	[0 to 99999999/0/1]
8-621-005	Func Use Counter	Function-005	CTL*	[0 to 99999999/0/1]
8-621-006	Func Use Counter	Function-006	CTL*	[0 to 99999999/0/1]
8-621-007	Func Use Counter	Function-007	CTL*	[0 to 99999999/0/1]
8-621-008	Func Use Counter	Function-008	CTL*	[0 to 99999999/0/1]
8-621-009	Func Use Counter	Function-009	CTL*	[0 to 99999999/0/1]
8-621-010	Func Use Counter	Function-010	CTL*	[0 to 99999999/0/1]
8-621-011	Func Use Counter	Function-011	CTL*	[0 to 99999999/0/1]
8-621-012	Func Use Counter	Function-012	CTL*	[0 to 99999999/0/1]
8-621-	Func Use Counter	Function-013	CTL*	[0 to 99999999/0/1]

3.SP Mode Tables

SP No.	Large Category	Small Category	ENG or CTL	[Min to Max/Init./Step]
013				
8-621-014	Func Use Counter	Function-014	CTL*	[0 to 99999999/0/1]
8-621-015	Func Use Counter	Function-015	CTL*	[0 to 99999999/0/1]
8-621-016	Func Use Counter	Function-016	CTL*	[0 to 99999999/0/1]
8-621-017	Func Use Counter	Function-017	CTL*	[0 to 99999999/0/1]
8-621-018	Func Use Counter	Function-018	CTL*	[0 to 99999999/0/1]
8-621-019	Func Use Counter	Function-019	CTL*	[0 to 99999999/0/1]
8-621-020	Func Use Counter	Function-020	CTL*	[0 to 99999999/0/1]
8-621-021	Func Use Counter	Function-021	CTL*	[0 to 99999999/0/1]
8-621-022	Func Use Counter	Function-022	CTL*	[0 to 99999999/0/1]
8-621-023	Func Use Counter	Function-023	CTL*	[0 to 99999999/0/1]
8-621-024	Func Use Counter	Function-024	CTL*	[0 to 99999999/0/1]
8-621-025	Func Use Counter	Function-025	CTL*	[0 to 99999999/0/1]
8-621-026	Func Use Counter	Function-026	CTL*	[0 to 99999999/0/1]
8-621-027	Func Use Counter	Function-027	CTL*	[0 to 99999999/0/1]
8-621-028	Func Use Counter	Function-028	CTL*	[0 to 99999999/0/1]
8-621-029	Func Use Counter	Function-029	CTL*	[0 to 99999999/0/1]
8-621-030	Func Use Counter	Function-030	CTL*	[0 to 99999999/0/1]
8-621-	Func Use Counter	Function-031	CTL*	[0 to 99999999/0/1]

## 3.SP Mode Tables

SP No.	Large Category	Small Category	ENG or CTL	[Min to Max/Init./Step]
031				
8-621-032	Func Use Counter	Function-032	CTL*	[0 to 99999999/0/1]
8-621-033	Func Use Counter	Function-033	CTL*	[0 to 99999999/0/1]
8-621-034	Func Use Counter	Function-034	CTL*	[0 to 99999999/0/1]
8-621-035	Func Use Counter	Function-035	CTL*	[0 to 99999999/0/1]
8-621-036	Func Use Counter	Function-036	CTL*	[0 to 99999999/0/1]
8-621-037	Func Use Counter	Function-037	CTL*	[0 to 99999999/0/1]
8-621-038	Func Use Counter	Function-038	CTL*	[0 to 99999999/0/1]
8-621-039	Func Use Counter	Function-039	CTL*	[0 to 99999999/0/1]
8-621-040	Func Use Counter	Function-040	CTL*	[0 to 99999999/0/1]
8-621-041	Func Use Counter	Function-041	CTL*	[0 to 99999999/0/1]
8-621-042	Func Use Counter	Function-042	CTL*	[0 to 99999999/0/1]
8-621-043	Func Use Counter	Function-043	CTL*	[0 to 99999999/0/1]
8-621-044	Func Use Counter	Function-044	CTL*	[0 to 99999999/0/1]
8-621-045	Func Use Counter	Function-045	CTL*	[0 to 99999999/0/1]
8-621-046	Func Use Counter	Function-046	CTL*	[0 to 99999999/0/1]
8-621-047	Func Use Counter	Function-047	CTL*	[0 to 99999999/0/1]
8-621-048	Func Use Counter	Function-048	CTL*	[0 to 99999999/0/1]
8-621-049	Func Use Counter	Function-049	CTL*	[0 to 99999999/0/1]

3.SP Mode Tables

SP No.	Large Category	Small Category	ENG or CTL	[Min to Max/Init./Step]
049				
8-621-050	Func Use Counter	Function-050	CTL*	[0 to 99999999/0/1]
8-621-051	Func Use Counter	Function-051	CTL*	[0 to 99999999/0/1]
8-621-052	Func Use Counter	Function-052	CTL*	[0 to 99999999/0/1]
8-621-053	Func Use Counter	Function-053	CTL*	[0 to 99999999/0/1]
8-621-054	Func Use Counter	Function-054	CTL*	[0 to 99999999/0/1]
8-621-055	Func Use Counter	Function-055	CTL*	[0 to 99999999/0/1]
8-621-056	Func Use Counter	Function-056	CTL*	[0 to 99999999/0/1]
8-621-057	Func Use Counter	Function-057	CTL*	[0 to 99999999/0/1]
8-621-058	Func Use Counter	Function-058	CTL*	[0 to 99999999/0/1]
8-621-059	Func Use Counter	Function-059	CTL*	[0 to 99999999/0/1]
8-621-060	Func Use Counter	Function-060	CTL*	[0 to 99999999/0/1]
8-621-061	Func Use Counter	Function-061	CTL*	[0 to 99999999/0/1]
8-621-062	Func Use Counter	Function-062	CTL*	[0 to 99999999/0/1]
8-621-063	Func Use Counter	Function-063	CTL*	[0 to 99999999/0/1]
8-621-064	Func Use Counter	Function-064	CTL*	[0 to 99999999/0/1]
8-771-001	Dev Counter	Total	CTL*	[0 to 99999999/0/1]
8-771-002	Dev Counter	K	CTL*	[0 to 99999999/0/1]
8-771-	Dev Counter	Y	CTL*	[0 to 99999999/0/1]

## 3.SP Mode Tables

SP No.	Large Category	Small Category	ENG or CTL	[Min to Max/Init./Step]
003				
8-771-004	Dev Counter	M	CTL*	[0 to 99999999/0/1]
8-771-005	Dev Counter	C	CTL*	[0 to 99999999/0/1]
8-781-001	Toner_Botol_Info.	BK	CTL*	[0 to 99999999/0/1]
8-781-002	Toner_Botol_Info.	Y	CTL*	[0 to 99999999/0/1]
8-781-003	Toner_Botol_Info.	M	CTL*	[0 to 99999999/0/1]
8-781-004	Toner_Botol_Info.	C	CTL*	[0 to 99999999/0/1]
8-801-001	Toner Remain	K	CTL*	[0 to 100/0/1%]
8-801-002	Toner Remain	Y	CTL*	[0 to 100/0/1%]
8-801-003	Toner Remain	M	CTL*	[0 to 100/0/1%]
8-801-004	Toner Remain	C	CTL*	[0 to 100/0/1%]
8-811-001	Eco Counter	Eco Total	CTL*	[0 to 99999999/0/1]
8-811-002	Eco Counter	Color	CTL*	[0 to 99999999/0/1]
8-811-003	Eco Counter	Full Color	CTL*	[0 to 99999999/0/1]
8-811-004	Eco Counter	Duplex	CTL*	[0 to 99999999/0/1]
8-811-005	Eco Counter	Combine	CTL*	[0 to 99999999/0/1]
8-811-006	Eco Counter	Color(%)	CTL*	[0 to 100/0/1%]
8-811-007	Eco Counter	Full Color(%)	CTL*	[0 to 100/0/1%]
8-811-	Eco Counter	Duplex(%)	CTL*	[0 to 100/0/1%]

3.SP Mode Tables

SP No.	Large Category	Small Category	ENG or CTL	[Min to Max/Init./Step]
008				
8-811-009	Eco Counter	Combine(%)	CTL*	[0 to 100/0/1%]
8-811-010	Eco Counter	Paper Cut(%)	CTL*	[0 to 100/0/1%]
8-811-051	Eco Counter	Sync Eco Total	CTL*	[0 to 99999999/0/1]
8-811-052	Eco Counter	Sync Color	CTL*	[0 to 99999999/0/1]
8-811-053	Eco Counter	Sync Full Color	CTL*	[0 to 99999999/0/1]
8-811-054	Eco Counter	Sync Duplex	CTL*	[0 to 99999999/0/1]
8-811-055	Eco Counter	Sync Combine	CTL*	[0 to 99999999/0/1]
8-811-056	Eco Counter	Sync Color(%)	CTL*	[0 to 100/0/1%]
8-811-057	Eco Counter	Sync Full Color(%)	CTL*	[0 to 100/0/1%]
8-811-058	Eco Counter	Sync Duplex(%)	CTL*	[0 to 100/0/1%]
8-811-059	Eco Counter	Sync Combine(%)	CTL*	[0 to 100/0/1%]
8-811-060	Eco Counter	Sync Paper Cut(%)	CTL*	[0 to 100/0/1%]
8-811-101	Eco Counter	Eco Totalr>Last	CTL*	[0 to 99999999/0/1]
8-811-102	Eco Counter	Color>Last	CTL*	[0 to 99999999/0/1]
8-811-103	Eco Counter	Full Color>Last	CTL*	[0 to 99999999/0/1]
8-811-104	Eco Counter	Duplex>Last	CTL*	[0 to 99999999/0/1]
8-811-105	Eco Counter	Combine>Last	CTL*	[0 to 99999999/0/1]
8-811-	Eco Counter	Color(%):Last	CTL*	[0 to 100/0/1%]

## 3.SP Mode Tables

SP No.	Large Category	Small Category	ENG or CTL	[Min to Max/Init./Step]
106				
8-811-107	Eco Counter	Full Color(%):Last	CTL*	[0 to 100/0/1%]
8-811-108	Eco Counter	Duplex(%):Last	CTL*	[0 to 100/0/1%]
8-811-109	Eco Counter	Combine(%):Last	CTL*	[0 to 100/0/1%]
8-811-110	Eco Counter	Paper Cut(%):Last	CTL*	[0 to 100/0/1%]
8-811-151	Eco Counter	Sync Eco Totalr:Last	CTL*	[0 to 99999999/0/1]
8-811-152	Eco Counter	Sync Color:Last	CTL*	[0 to 99999999/0/1]
8-811-153	Eco Counter	Sync Full Color:Last	CTL*	[0 to 99999999/0/1]
8-811-154	Eco Counter	Sync Duplex:Last	CTL*	[0 to 99999999/0/1]
8-811-155	Eco Counter	Sync Combine:Last	CTL*	[0 to 99999999/0/1]
8-811-156	Eco Counter	Sync Color(%):Last	CTL*	[0 to 100/0/1%]
8-811-157	Eco Counter	Sync Full Color(%):Last	CTL*	[0 to 100/0/1%]
8-811-158	Eco Counter	Sync Duplex(%):Last	CTL*	[0 to 100/0/1%]
8-811-159	Eco Counter	Sync Combine(%):Last	CTL*	[0 to 100/0/1%]
8-811-160	Eco Counter	Sync Paper Cut(%):Last	CTL*	[0 to 100/0/1%]
8-851-011	Cvr Cnt:0-10%	0~2%:BK	CTL*	[0 to 99999999/0/1]
8-851-012	Cvr Cnt:0-10%	0~2%:Y	CTL*	[0 to 99999999/0/1]
8-851-013	Cvr Cnt:0-10%	0~2%:M	CTL*	[0 to 99999999/0/1]
8-851-	Cvr Cnt:0-10%	0~2%:C	CTL*	[0 to 99999999/0/1]

3.SP Mode Tables

SP No.	Large Category	Small Category	ENG or CTL	[Min to Max/Init./Step]
014				
8-851-021	Cvr Cnt:0-10%	3~4%:BK	CTL*	[0 to 99999999/0/1]
8-851-022	Cvr Cnt:0-10%	3~4%:Y	CTL*	[0 to 99999999/0/1]
8-851-023	Cvr Cnt:0-10%	3~4%:M	CTL*	[0 to 99999999/0/1]
8-851-024	Cvr Cnt:0-10%	3~4%:C	CTL*	[0 to 99999999/0/1]
8-851-031	Cvr Cnt:0-10%	5~7%:BK	CTL*	[0 to 99999999/0/1]
8-851-032	Cvr Cnt:0-10%	5~7%:Y	CTL*	[0 to 99999999/0/1]
8-851-033	Cvr Cnt:0-10%	5~7%:M	CTL*	[0 to 99999999/0/1]
8-851-034	Cvr Cnt:0-10%	5~7%:C	CTL*	[0 to 99999999/0/1]
8-851-041	Cvr Cnt:0-10%	8~10%:BK	CTL*	[0 to 99999999/0/1]
8-851-042	Cvr Cnt:0-10%	8~10%:Y	CTL*	[0 to 99999999/0/1]
8-851-043	Cvr Cnt:0-10%	8~10%:M	CTL*	[0 to 99999999/0/1]
8-851-044	Cvr Cnt:0-10%	8~10%:C	CTL*	[0 to 99999999/0/1]
8-861-001	Cvr Cnt:11-20%	BK	CTL*	[0 to 99999999/0/1]
8-861-002	Cvr Cnt:11-20%	Y	CTL*	[0 to 99999999/0/1]
8-861-003	Cvr Cnt:11-20%	M	CTL*	[0 to 99999999/0/1]
8-861-004	Cvr Cnt:11-20%	C	CTL*	[0 to 99999999/0/1]
8-871-001	Cvr Cnt:21-30%	BK	CTL*	[0 to 99999999/0/1]
8-871-	Cvr Cnt:21-30%	Y	CTL*	[0 to 99999999/0/1]

## 3.SP Mode Tables

SP No.	Large Category	Small Category	ENG or CTL	[Min to Max/Init./Step]
002				
8-871-003	Cvr Cnt:21-30%	M	CTL*	[0 to 99999999/0/1]
8-871-004	Cvr Cnt:21-30%	C	CTL*	[0 to 99999999/0/1]
8-881-001	Cvr Cnt:31%-	BK	CTL*	[0 to 99999999/0/1]
8-881-002	Cvr Cnt:31%-	Y	CTL*	[0 to 99999999/0/1]
8-881-003	Cvr Cnt:31%-	M	CTL*	[0 to 99999999/0/1]
8-881-004	Cvr Cnt:31%-	C	CTL*	[0 to 99999999/0/1]
8-891-001	Page/Toner Bottle	BK	CTL*	[0 to 99999999/0/1]
8-891-002	Page/Toner Bottle	Y	CTL*	[0 to 99999999/0/1]
8-891-003	Page/Toner Bottle	M	CTL*	[0 to 99999999/0/1]
8-891-004	Page/Toner Bottle	C	CTL*	[0 to 99999999/0/1]
8-901-001	Page/Ink_Prev1	BK	CTL*	[0 to 99999999/0/1]
8-901-002	Page/Ink_Prev1	Y	CTL*	[0 to 99999999/0/1]
8-901-003	Page/Ink_Prev1	M	CTL*	[0 to 99999999/0/1]
8-901-004	Page/Ink_Prev1	C	CTL*	[0 to 99999999/0/1]
8-911-001	Page/Ink_Prev2	BK	CTL*	[0 to 99999999/0/1]
8-911-002	Page/Ink_Prev2	Y	CTL*	[0 to 99999999/0/1]
8-911-003	Page/Ink_Prev2	M	CTL*	[0 to 99999999/0/1]
8-911-004	Page/Ink_Prev2	C	CTL*	[0 to 99999999/0/1]

3.SP Mode Tables

SP No.	Large Category	Small Category	ENG or CTL	[Min to Max/Init./Step]
004				
8-921-001	Cvr Cnt/Total	Coverage(%):BK	CTL*	[0 to 2147483647/0/1%]
8-921-002	Cvr Cnt/Total	Coverage(%):Y	CTL*	[0 to 2147483647/0/1%]
8-921-003	Cvr Cnt/Total	Coverage(%):M	CTL*	[0 to 2147483647/0/1%]
8-921-004	Cvr Cnt/Total	Coverage(%):C	CTL*	[0 to 2147483647/0/1%]
8-921-011	Cvr Cnt/Total	Coverage/P:BK	CTL*	[0 to 99999999/0/1]
8-921-012	Cvr Cnt/Total	Coverage/P:Y	CTL*	[0 to 99999999/0/1]
8-921-013	Cvr Cnt/Total	Coverage/P:M	CTL*	[0 to 99999999/0/1]
8-921-014	Cvr Cnt/Total	Coverage/P:C	CTL*	[0 to 99999999/0/1]
8-921-031	Cvr Cnt/Total	Coverage(%):Eco BK	CTL*	[0 to 2147483647/0/1%]
8-921-032	Cvr Cnt/Total	Coverage(%):Eco Y	CTL*	[0 to 2147483647/0/1%]
8-921-033	Cvr Cnt/Total	Coverage(%):Eco M	CTL*	[0 to 2147483647/0/1%]
8-921-034	Cvr Cnt/Total	Coverage(%):Eco C	CTL*	[0 to 2147483647/0/1%]
8-921-041	Cvr Cnt/Total	Coverage/P:Eco BK	CTL*	[0 to 99999999/0/1]
8-921-042	Cvr Cnt/Total	Coverage/P:Eco Y	CTL*	[0 to 99999999/0/1]
8-921-043	Cvr Cnt/Total	Coverage/P:Eco M	CTL*	[0 to 99999999/0/1]
8-921-044	Cvr Cnt/Total	Coverage/P:Eco C	CTL*	[0 to 99999999/0/1]
8-941-001	Machine Status	Operation Time	CTL*	[0 to 99999999/0/1]
8-941-	Machine Status	Standby Time	CTL*	[0 to 99999999/0/1]

## 3.SP Mode Tables

SP No.	Large Category	Small Category	ENG or CTL	[Min to Max/Init./Step]
002				
8-941-003	Machine Status	Energy Save Time	CTL*	[0 to 99999999/0/1]
8-941-004	Machine Status	Low Power Time	CTL*	[0 to 99999999/0/1]
8-941-005	Machine Status	Off Mode Time	CTL*	[0 to 99999999/0/1]
8-941-006	Machine Status	SC	CTL*	[0 to 99999999/0/1]
8-941-007	Machine Status	PrtJam	CTL*	[0 to 99999999/0/1]
8-941-008	Machine Status	OrgJam	CTL*	[0 to 99999999/0/1]
8-941-009	Machine Status	Supply PM Unit End	CTL*	[0 to 99999999/0/1]
8-961-001	Electricity Status	Ctrl Standby Time	CTL*	[0 to 99999999/0/1]
8-961-002	Electricity Status	STR Time	CTL*	[0 to 99999999/0/1]
8-961-003	Electricity Status	Main Power Off Time	CTL*	[0 to 99999999/0/1]
8-961-004	Electricity Status	Reading and Printing Time	CTL*	[0 to 99999999/0/1]
8-961-005	Electricity Status	Printing Time	CTL*	[0 to 99999999/0/1]
8-961-006	Electricity Status	Reading Time	CTL*	[0 to 99999999/0/1]
8-961-007	Electricity Status	Eng Waiting Time	CTL*	[0 to 99999999/0/1]
8-961-008	Electricity Status	Low Pauer State Time	CTL*	[0 to 99999999/0/1]
8-961-009	Electricity Status	Silent State Time	CTL*	[0 to 99999999/0/1]
8-961-010	Electricity Status	Heater Off State Time	CTL*	[0 to 99999999/0/1]
8-961-	Electricity Status	LCD on Time	CTL*	[0 to 99999999/0/1]

### 3.SP Mode Tables

SP No.	Large Category	Small Category	ENG or CTL	[Min to Max/Init./Step]
011				
8-961-101	Electricity Status	Silent Print	CTL*	[0 to 99999999/0/1]
8-971-001	Unit Control	Engine Off Recovery Count	CTL*	[0 to 99999999/0/1]
8-971-002	Unit Control	Power Off Count	CTL*	[0 to 99999999/0/1]
8-971-003	Unit Control	Force Power Off Count	CTL*	[0 to 99999999/0/1]
8-999-001	AdminCounter	Total	CTL*	[0 to 99999999/0/1]
8-999-006	AdminCounter	Printer:FC	CTL*	[0 to 99999999/0/1]
8-999-007	AdminCounter	Printer:BW	CTL*	[0 to 99999999/0/1]
8-999-008	AdminCounter	Printer:OneC	CTL*	[0 to 99999999/0/1]
8-999-009	AdminCounter	Printer:TwoC	CTL*	[0 to 99999999/0/1]
8-999-013	AdminCounter	Duplex	CTL*	[0 to 99999999/0/1]
8-999-026	AdminCounter	Printer:FC %	CTL*	[0 to 2147483647/0/1]
8-999-027	AdminCounter	Printer:BW %	CTL*	[0 to 2147483647/0/1]
8-999-028	AdminCounter	Printer:OneC %	CTL*	[0 to 2147483647/0/1]
8-999-029	AdminCounter	Printer:TwoC %	CTL*	[0 to 2147483647/0/1]

## Printer Service Mode

### Printer Service Mode

1001	Bit Switch			
001	Bit Switch 1		0	1
	bit 0	<b>DFU</b>	-	-
	bit 1	<b>Responding with the hostname as the sysName</b>	<b>Model name (PnP name)</b>	Hostname
		This BitSwitch can change the value of the sysName. <ul style="list-style-type: none"> <li>0 (default): Model name (PnP name) such as "P C600"</li> <li>1: Host name</li> </ul>		
	bit 2	<b>DFU</b>	-	-
	bit 3	<b>No I/O Timeout</b>	<b>Disabled</b>	Enabled
		Enables/Disables MFP I/O Timeouts. If enabled, the MFP I/O Timeout setting will have no affect. I/O Timeouts will never occur.		
	bit 4	<b>SD Card Save Mode</b>	<b>Disabled</b>	Enabled
		If this BitSwitch is enabled, print jobs will be saved to the GW SD slot and not output to paper.		
	bit 5	<b>[PS and PDF] Paper size error margin</b>	<b>±5pt</b>	±10pt
		When a PS job is printed by using a custom paper size, the job might not be printed because of a paper size mismatch caused by a calculation error. By default, the error margin for matching to a paper size is ±5 points. By enabling this bit switch, the error margin for matching to a paper size can be extended to ±10 points.		
	bit 6	<b>Color Balance Switching 1</b>	<b>Standard Color Balance</b>	FX compatibility
		This BitSw can be used to restore the color balance to match that of Fuji-Xerox devices. Note: If both BitSw #2-0, BitSw #2-4 and BitSw #1-6 are configured to "1", the configuration of #2-0 will be given priority and the color balance of 09S and earlier models will be used.		
	bit 7	<b>[RPCS,PCL]: Printable area frame border</b>	<b>Disabled</b>	Enabled
		Prints all RPCS and PCL jobs with a border around the printable area.		

1001	Bit Switch			
002	Bit Switch 2		0	1
	bit	<b>Color Balance</b>	<b>Standard Color</b>	Color balance of 09S and earlier

### 3.SP Mode Tables

1001	Bit Switch			
	0	<b>Switching 2</b>	<b>Balance</b>	models
		<p>This BitSw can be used to restore the color balance to match 09S and earlier model devices.</p> <p>Note: If both BitSw #2-0 and BitSw #2-4 are configured to "1", the configuration of #2-0 will be given priority and the color balance of 09S and earlier models will be used.</p>		
	bit 1	<b>DFU</b>	-	-
	bit 2	<b>Not used</b>	-	-
	bit 3	<b>PDL Auto Switching</b>	<b>Enabled</b>	Disabled
		<p>Enables/disable the MFPs ability to change the PDL processor mid-job. Some host systems submit jobs that contain both PS and PCL. If Auto PDL switching is disabled, these jobs will not be printed properly.</p>		
	bit 4	<b>Color Balance Switching 3</b>	<b>Standard Color Balance</b>	Color balance of 09A and extended 09A models
		<p>This BitSw can be used to restore the color balance to match 09A and extended 09A model devices.</p> <p>Note: If both BitSw #2-0 and BitSw #2-4 are configured to "1", the configuration of #2-0 will be given priority and the color balance of 09S and earlier models will be used.</p>		
	bit 5	<b>DFU</b>	-	-
	bit 6	<b>Not used</b>	-	-
	bit 7	<b>DFU</b>	-	-

1001	Bit Switch				
003	Bit Switch 3			0	1
	bit 0 to 1	<b>DFU</b>	-	-	
	bit 2	<b>[PCL5e/c]: Legacy HP compatibility</b>	<b>Disabled</b>	Enabled	
		<p>Uses the same left margin as older HP models such as HP4000/HP8000.</p> <p>In other words, the left margin defined in the job (usually "&lt;ESC&gt;*r0A") will be changed to "&lt;ESC&gt;*r1A".</p>			
	bit 3 to 7	<b>DFU</b>	-	-	

1001	Bit Switch			
004	Bit Switch 4		0	1
	bit 0 to 5	<b>DFU</b>	-	-
	bit 6	<b>Bypass tray paper direction</b>	LEF	<b>SEF</b>
		Changes the paper direction used with "Machine Setting(s): Any Type" in the bypass tray. This setting enables the direction of the paper in the bypass tray to specified.		
	bit 7	<b>DFU</b>	-	-

1001	Bit Switch			
005	Bit Switch 5		0	1
	bit 0	<b>Not used</b>	-	-
	bit 1	<b>Multiple copies if a paper size or type mismatch occurs</b>	<b>Disabled (Single copy)</b>	Enabled (Multiple copy)
		If a paper size or type mismatch occurs during the printing of multiple copies, only a single copy is output by default. Using this BitSwitch, the device can be configured to print all copies even if a paper mismatch occurs.		
	bit 2	<b>Prevent SDK applications from altering the contents of a job.</b>	<b>Disabled</b>	Enabled
		If this BitSwitch is enabled, SDK applications will not be able to alter print data. This is achieved by preventing SDK applications from accessing a module called the "GPS Filter". <b>Note:</b> The main purpose of this BitSwitch is for troubleshooting the effects of SDK applications on data.		
	bit 3	<b>[PS] PS Criteria</b>	<b>Pattern3</b>	Pattern1
		Change the number of PS criterion used by the PS interpreter to determine whether a job is PS data or not. <ul style="list-style-type: none"> <li>Pattern3: The larger the pattern number, the greater the number of criterion used.</li> <li>Pattern1: A small number of PS tags and headers</li> </ul>		
	bit 4	<b>Increase max. number of stored jobs.</b>	<b>Disabled (100)</b>	Enabled
		Changes the maximum number of jobs that can be stored on the HDD. The default (disabled) is 100. If this is enabled, the max. will be raised to 750 or 1000 depending on the model.		
	bit 5	<b>Not used</b>	-	-
	bit 6	<b>Method for determining the image rotation for the edge to bind on.</b>	<b>Disabled</b>	Enabled

### 3.SP Mode Tables

1001	Bit Switch		
		<p>If enabled, the image rotation will be performed as they were in the specifications of older models for the binding of pages of mixed orientation jobs.</p> <p>The old models are below:</p> <ul style="list-style-type: none"> <li>- PCL: Pre-04A models</li> <li>- PS/PDF:Pre-05S models</li> </ul>	
	bit 7	<b>Letterhead mode printing</b>	<p><b>Disabled</b>      Enabled (Duplex)</p> <p>Routes all pages through the duplex unit.</p> <p>If this is disabled, simplex pages or the last page of an odd-paged duplex job, are not routed through the duplex unit. This could result in problems with letterhead/pre-printed pages.</p> <p>Only affects pages specified as Letterhead paper.</p>

1001	Bit Switch			
006	Bit Switch 6		0	1
	bit 0 to 1	<b>Not used</b>	-	-
	bit 2 to 3	<b>DFU</b>	-	-
	bit 4 to 7	<b>Not used</b>	-	-

1001	Bit Switch			
007	Bit Switch 7		0	1
	bit 0 to 7	<b>DFU</b>	-	-

1001	Bit Switch			
008	Bit Switch 8		0	1
	bit 0 to 2	<b>DFU</b>	-	-
	bit 3	<b>BW Printing without the PjL Color Command "DATAMODE"</b>	<b>Disabled</b>	Enabled
		<p>This setting enables a job to be printed in BW without the PjL color command "DATAMODE".</p> <p>Note: Color jobs will not be printed without the PjL color command "DATAMODE".</p> <p>Note: This is available for PCL, PS only.</p>		
	bit 4 to 5	<b>DFU</b>	-	-
	bit 6	<b>PjL/PDL Color Command Priority</b>	<b>PjL Priority</b>	PDL Priority
		<p>This setting enables the priority of a PDL color command to be changed when a PjL color command is "@PjL RENDERMODE = GRAYSCALE" in a job.</p>		

1001	Bit Switch			
		Note: This is available for PCL, RPCS, PS.		
	bit 7	<b>DFU</b>	-	-

1001	Bit Switch			
009	Bit Switch 9		0	1
	bit 0	<b>PDL Auto Detection timeout of jobs submitted via USB or Parallel Port (IEEE 1284).</b>	<b>Disabled (Immediately)</b>	Enabled (10 seconds)
	To be used if PDL auto-detection fails. A failure of PDL autodetection does not necessarily mean that the job can't be printed. This bit switch tells the device whether to time-out immediately (default) upon failure or to wait 10 seconds.			
	bit 1	<b>Not used</b>	-	-
	bit 2	<b>Job Cancel</b>	<b>Disabled (Not cancelled)</b>	Enabled (Cancelled)
	If this bit switch, all jobs will be cancelled after a jam occurs. <b>Note:</b> If this BitSwitch is enabled, printing under the following conditions might result in problems: - Job submission via USB or Parallel Port - Spool printing (WIM > Configuration > Device Settings > System)			
	bit 3	<b>Not used</b>	-	-
	bit 4	<b>Timing of the PjL Status ReadBack (JOB END) when printing multiple collated copies.</b>	<b>Disabled</b>	Enabled
	This BitSwitch determines the timing of the PjL USTATUS JOB END sent when multiple collated copies are being printed. <ul style="list-style-type: none"> <li>0 (default): JOB END is sent by the device to the client after the first copy has completed printing. This causes the page counter to be incremented after the first copy and then again at the end of the job.</li> <li>1: JOB END is sent by the device to the client after the last copy has finished printing. This causes the page counter to be incremented at the end of each job.</li> </ul>			
	bit 5	<b>Display UTF-8 text in the operation panel</b>	<b>Enabled</b>	Disabled
	<ul style="list-style-type: none"> <li>Enabled (=0): Text composed of UTF-8 characters can be displayed in the operation panel.</li> <li>Disabled (=1): UTF-8 characters cannot be displayed in the operation panel.</li> </ul> For example, job names are sometimes stored in the MIB using UTF-8 encoded			

3.SP Mode Tables

1001		Bit Switch		
		characters. When these are displayed on the operation panel, they will be garbled unless this BitSwitch is enabled (=0).		
	bit	<b>Disable super option</b>	<b>Disabled</b>	Enabled
	6	Switches super option disable on / off. If this is On, multiple jobs are grouped at LPR port. PjL settings are enabled even jobs that are specified queue names are sent.		
	bit	<b>DFU</b>	-	-
	7			

1001		Bit Switch		
010	Bit Switch A		0	1
	bit 0 to 7		<b>DFU</b>	-

1001		Bit Switch		
011	Bit Switch B		0	1
	bit	<b>DFU</b>	-	-
	0			
	bit	<b>Print job interruption</b>	<b>Does not allow interruption</b>	Allow interruption
	1	<ul style="list-style-type: none"> <li>0 (default): Print jobs are not interrupted. If a job is promoted to the top of the print queue, it will wait for the currently printing job to finish.</li> <li>1: If a job is promoted to the top of the queue, it will interrupt the currently printing job and start printing immediately.</li> </ul>		
	bit	<b>Switch for enabling or disabling Limitless Paper Feeding for the Bypass Tray</b>	<b>Enabled</b>	Disabled
	2	<p>When the Bypass Tray is the target of the Auto Tray Select and Any Size/Type is configured for the Tray Setting Priority setting of the Bypass Tray, this BitSwitch can switch the behavior whether or not Limitless Paper Feeding is applied to the Bypass Tray.* The default is Enabled (=0).</p> <p>*Limitless Paper Feeding will try a matching tray of the next highest priority if a job specified to Auto Tray Select as the tray setting is submitted and the tray runs out of paper.</p> <ul style="list-style-type: none"> <li>Enabled (=0: Default): Limitless Paper Feeding is applied to the Bypass Tray. If a tray other than the Bypass Tray matches the job's paper size and type but has run out of paper, printing will occur from the Bypass Tray.</li> <li>Disabled (=1): Limitless Paper Feeding is not applied to the Bypass Tray. If a tray other than the Bypass Tray matches the job's paper size and type but has run out of paper, printing will stop and an alert will appear on the LCD screen, stating that the</li> </ul>		

1001	Bit Switch			
		tray has run out of paper. This prevents unexpected use of the Bypass Tray. Limitations when this BitSwitch is set to "1": - The "Paper Tray Priority: Printer" setting must be configured to a tray other than the Bypass Tray. - Jobs that contain more than one paper size cannot be printed.		
	bit 3	<b>Not used</b>	-	-
	bit 4	<b>Add "Apply Auto Paper Select" is the condition that decides if the device's paper size or paper type should be overwritten.</b>	<b>Disabled</b>	Enabled
		If this BitSwitch is set to "1" (enabled), the "Apply Auto Paper Select" setting will decide if the paper size or paper type that is specified in the device settings should be overwritten by the job's commands when "Tray Setting Priority" is set to "Driver/Command" or "Any Type". - Apply Auto Paper Select = OFF: Overwritten (priority is given to the job's commands) - Apply Auto Paper Select = ON: Not overwritten (priority is given to the device settings)		
	bit 5	<b>DFU</b>	-	-
	Bit 6	<b>The tray selection setting when a paper size or paper type mismatch occurs.</b>	<b>Disabled</b>	Enabled
		If the tray selection setting is enabled, selecting the tray that the "Apply Auto Paper Select" setting is configured to "Off" cannot be done when a paper size or paper type mismatch occurs.		
	bit 7	<b>DFU</b>	-	-

1001	Bit Switch			
012	Bit Switch C		0	1
	bit 0 to 4	<b>DFU</b>	-	-
	bit 5	<b>Change the user ID type displayed on the operation panel</b>	<b>Disabled</b>	Enabled
		As of 15S models, the Login User Name can be displayed on the operation panel. The user ID type displayed on the operation panel can be changed by configuring BitSwitch #12-5 as follows: <ul style="list-style-type: none"> <li>• 0 (default): Login User Name</li> <li>• 1: User ID. If this is enabled, User ID will be displayed, which is equivalent to the</li> </ul>		

### 3.SP Mode Tables

1001	Bit Switch			
	behavior exhibited in 14A and earlier models.			
	bit 6	<b>AirPrint</b>	<b>Enabled</b>	Disabled
	AirPrint can be disabled by changing this BitSwitch from 0 (default) to 1.			
	bit 7	<b>AirPrint PDF</b>	<b>Enabled</b>	Disabled
	AirPrint PDF can be disabled by changing this BitSwitch from 0 (default) to 1.			

1002	Bit Switch2			
001	Bit Switch (2) 1		0	1
	bit 0	Paper size mismatch display	<b>Enabled</b>	Disabled
	Display warning screen (40909) of paper size mismatch.			
	bit 1 to 7	DFU	-	-

1002	Bit Switch2			
002	Bit Switch (2) 2		0	1
	bit 0 to 7	DFU	-	-

1002	Bit Switch2			
003	Bit Switch (2) 3		0	1
	bit 0 to 7	DFU	-	-

1002	Bit Switch2			
004	Bit Switch (2) 4		0	1
	bit 0 to 7	DFU	-	-

1002	Bit Switch2			
005	Bit Switch (2) 5		0	1
	bit 0	PDF fast printing	<b>Enabled</b>	Disabled
	Prints PDF files in a specific format faster.			
	bit 1 to 7	DFU	-	-

1002	Bit Switch2			
006	Bit Switch (2) 6		0	1
	bit 0 to 7	DFU	-	-

1002	Bit Switch2			
007	Bit Switch (2) 7		0	1

1002	Bit Switch2			
	bit 0 to 7	DFU	-	-

1002	Bit Switch2			
008	Bit Switch (2) 8		0	1
	bit 0 to 7	DFU	-	-

1002	Bit Switch2			
009	Bit Switch (2) 9		0	1
	bit 0 to 7	DFU	-	-

1002	Bit Switch2			
010	Bit Switch (2) 10		0	1
	bit 0 to 7	DFU	-	-

1002	Bit Switch2			
011	Bit Switch (2) 11		0	1
	bit 0 to 7	DFU	-	-

1002	Bit Switch2			
012	Bit Switch (2) 12		0	1
	bit 0 to 7	DFU	-	-

1003	[Clear Setting]		
1003-001	Initialize System	Initializes settings in the System menu of the user mode.	
1003-003	Delete Program	DFU	

1004	[Print Summary]		
1004-001	Service Summary	Prints the service summary sheet (a summary of all the controller settings).	
1004-002	Service Summary2		

1101	[ToneCtlSet]		
	Recalls a set of gamma settings. This can be either a) the factory setting, b) the previous setting, or c) the current setting		
1101-001	Tone (Factory)	CTL	[ - / - / - ] [Execute]

### 3.SP Mode Tables

1101-002	Tone (Prev.)	CTL	
1101-003	Tone (Current)	CTL	

<b>1102</b>	<b>[ToneCtlSet]</b>		
	Selects the printing mode (resolution) for the printer gamma adjustment.		
1102-001	ToneCtlSet	CTL	[0 to 7 / 0 / 1/step] 0: 1200x1200 Photo (1bit/4col) 1: 600x600 Photo (4bit/4col) 2: 600x600 Photo (2bit/4col) 3: 600x600 Photo (1bit/4col) 4: 1200x1200 Text (1bit/4col) 5: 600x600 Text (4bit/4col) 6: 600x600 Text (2bit/4col) 7: 600x600 Text (1bit/4col)

<b>1103</b>	<b>[PrnColorSheet]</b>		
	Prints the test page to check the color balance before and after the gamma adjustment.		
1103-001	ToneCtlSheet	CTL	[ - / - / - ]
1103-002	ColorChart	CTL	[Execute]

<b>1104</b>	<b>[ToneCtlValue]</b>		
	Adjusts the printer gamma.		
1104-001	Set Black 1	CTL	[0 to 255 / 16 / 1/step]
1104-002	Set Black 2	CTL	[0 to 255 / 32 / 1/step]
1104-003	Set Black 3	CTL	[0 to 255 / 48 / 1/step]
1104-004	Set Black 4	CTL	[0 to 255 / 64 / 1/step]
1104-005	Set Black 5	CTL	[0 to 255 / 80 / 1/step]
1104-006	Set Black 6	CTL	[0 to 255 / 96 / 1/step]
1104-007	Set Black 7	CTL	[0 to 255 / 112 / 1/step]
1104-008	Set Black 8	CTL	[0 to 255 / 128 / 1/step]
1104-009	Set Black 9	CTL	[0 to 255 / 144 / 1/step]
1104-010	Set Black 10	CTL	[0 to 255 / 160 / 1/step]
1104-011	Set Black 11	CTL	[0 to 255 / 176 / 1/step]
1104-012	Set Black 12	CTL	[0 to 255 / 192 / 1/step]
1104-013	Set Black 13	CTL	[0 to 255 / 208 / 1/step]
1104-014	Set Black 14	CTL	[0 to 255 / 224 / 1/step]

## 3.SP Mode Tables

1104-015	Set Black 15	CTL	[0 to 255 / 240 / 1/step]
1104-021	Set Cyan 1	CTL	[0 to 255 / 16 / 1/step]
1104-022	Set Cyan 2	CTL	[0 to 255 / 32 / 1/step]
1104-023	Set Cyan 3	CTL	[0 to 255 / 48 / 1/step]
1104-024	Set Cyan 4	CTL	[0 to 255 / 64 / 1/step]
1104-025	Set Cyan 5	CTL	[0 to 255 / 80 / 1/step]
1104-026	Set Cyan 6	CTL	[0 to 255 / 96 / 1/step]
1104-027	Set Cyan 7	CTL	[0 to 255 / 112 / 1/step]
1104-028	Set Cyan 8	CTL	[0 to 255 / 128 / 1/step]
1104-029	Set Cyan 9	CTL	[0 to 255 / 144 / 1/step]
1104-030	Set Cyan 10	CTL	[0 to 255 / 160 / 1/step]
1104-031	Set Cyan 11	CTL	[0 to 255 / 176 / 1/step]
1104-032	Set Cyan 12	CTL	[0 to 255 / 192 / 1/step]
1104-033	Set Cyan 13	CTL	[0 to 255 / 208 / 1/step]
1104-034	Set Cyan 14	CTL	[0 to 255 / 224 / 1/step]
1104-035	Set Cyan 15	CTL	[0 to 255 / 240 / 1/step]
1104-041	Set Magenta 1	CTL	[0 to 255 / 16 / 1/step]
1104-042	Set Magenta 2	CTL	[0 to 255 / 32 / 1/step]
1104-043	Set Magenta 3	CTL	[0 to 255 / 48 / 1/step]
1104-044	Set Magenta 4	CTL	[0 to 255 / 64 / 1/step]
1104-045	Set Magenta 5	CTL	[0 to 255 / 80 / 1/step]
1104-046	Set Magenta 6	CTL	[0 to 255 / 96 / 1/step]
1104-047	Set Magenta 7	CTL	[0 to 255 / 112 / 1/step]
1104-048	Set Magenta 8	CTL	[0 to 255 / 128 / 1/step]
1104-049	Set Magenta 9	CTL	[0 to 255 / 144 / 1/step]
1104-050	Set Magenta 10	CTL	[0 to 255 / 160 / 1/step]
1104-051	Set Magenta 11	CTL	[0 to 255 / 176 / 1/step]
1104-052	Set Magenta 12	CTL	[0 to 255 / 192 / 1/step]
1104-053	Set Magenta 13	CTL	[0 to 255 / 208 / 1/step]
1104-054	Set Magenta 14	CTL	[0 to 255 / 224 / 1/step]
1104-055	Set Magenta 15	CTL	[0 to 255 / 240 / 1/step]
1104-061	Set Yellow 1	CTL	[0 to 255 / 16 / 1/step]
1104-062	Set Yellow 2	CTL	[0 to 255 / 32 / 1/step]
1104-063	Set Yellow 3	CTL	[0 to 255 / 48 / 1/step]
1104-064	Set Yellow 4	CTL	[0 to 255 / 64 / 1/step]
1104-065	Set Yellow 5	CTL	[0 to 255 / 80 / 1/step]
1104-066	Set Yellow 6	CTL	[0 to 255 / 96 / 1/step]
1104-067	Set Yellow 7	CTL	[0 to 255 / 112 / 1/step]

### 3.SP Mode Tables

1104-068	Set Yellow 8	CTL	[0 to 255 / 128 / 1/step]
1104-069	Set Yellow 9	CTL	[0 to 255 / 144 / 1/step]
1104-070	Set Yellow 10	CTL	[0 to 255 / 160 / 1/step]
1104-071	Set Yellow 11	CTL	[0 to 255 / 176 / 1/step]
1104-072	Set Yellow 12	CTL	[0 to 255 / 192 / 1/step]
1104-073	Set Yellow 13	CTL	[0 to 255 / 208 / 1/step]
1104-074	Set Yellow 14	CTL	[0 to 255 / 224 / 1/step]
1104-075	Set Yellow 15	CTL	[0 to 255 / 240 / 1/step]

<b>1105</b>	<b>ToneCtlSave</b>		
	Stores the print gamma adjusted with the "ToneCtlValu" menu item as the current setting. Before the machine stores the new "current setting", it moves the data currently stored as the "current setting" to the "previous setting" memory storage location.		
1105-001	ToneCtlSave	*CTL	[ - / - / - ] [Execute]

<b>1106</b>	<b>[TonerLimit]</b>		
	Adjusts the maximum toner amount for image development.		
1106-001	TonerLimitValue	*CTL	[0 to 400 / 0 / 1 %/step ]

<b>1108</b>	<b>[Ext.TonerSave]</b>		
	Adjusts the density of each object type.		
1108-001	Mode1:Text	*CTL	[0 to 255 / 75 / 1/step ]
1108-002	Mode2:Text	*CTL	[0 to 255 / 50 / 1/step ]
1108-003	Mode1:Image	*CTL	[0 to 255 / 75 / 1/step ]
1108-004	Mode2:Image	*CTL	[0 to 255 / 50 / 1/step ]
1108-005	Mode1:Line	*CTL	[0 to 255 / 75 / 1/step ]
1108-006	Mode2:Line	*CTL	[0 to 255 / 50 / 1/step ]
1108-007	Mode1:Paint	*CTL	[0 to 255 / 75 / 1/step ]
1108-008	Mode2:Paint	*CTL	[0 to 255 / 50 / 1/step ]

<b>1109</b>	<b>[EconomyColor]</b>		
	Adjusts the density of each object type used when printing in economy color mode.		
1109-001	Text	*CTL	[0 to 999 / 100 / 1/step ]
1109-002	Image	*CTL	[0 to 999 / 50 / 1/step ]
1109-003	Line	*CTL	[0 to 999 / 30 / 1/step ]
1109-004	Paint	*CTL	[0 to 999 / 30 / 1/step ]

<b>1113</b>	<b>[IBACC Exec]</b>		
	Sets IBACC correction execution (calculation IBACC gamma) on / off. 0: Not calculate IBACC gamma. (Sets IBACC gamma linear) 1: Calculate IBACC gamma		
1113-001	0:Off 1:On	*CTL	[0 or 1 / 1 / 1/step]

<b>1114</b>	<b>[IBACC ToneCtlSet]</b>		
	Sets back to the previous value of IBACC gamma correction for all resolutions. If there is no previous value, sets to the factory default values.		
1114-001	Tone (Prev.)	CTL	-
1114-002	Tone (Factory)	CTL	-

<b>1115</b>	<b>[IBACC Exec Time]</b>		
	Displays the time when IBACC is executed or set back to the previous / initial value.		
1115-001	Time	CTL	-

<b>1121</b>	<b>Introduction Setting Boot Mode</b>		
	Set whether to boot the machine in introduction setting mode.		
1121-001	0:Off 1:On	*CTL	[0 or 1 / 0 / 1/step]

## Input and Output Check

### Input Check Table (SP5-803)

When entering the Input Check mode, 8 digits display the result for a section. Each digit corresponds to a different device as shown in the table.

Bit No.	7	6	5	4	3	2	1	0
Result	0 or 1	0 or 1	0 or 1	0 or 1	0 or 1	0 or 1	0 or 1	0 or 1

SP	Description	Reading	
		0	1
5-803-001	Exit Full Sensor	Paper not detected	Paper detected
5-803-002	Du On Sensor	Paper not detected	Paper detected
5-803-003	Fuser Exit On Sensor	Paper not detected	Paper detected
5-803-004	Regist Sens On Sensor	Paper not detected	Paper detected
5-803-005	MPF Jam On Sensor	Paper not detected	Paper detected
5-803-010	Outside temperature	-	-
5-803-011	Outside humidity	-	-
5-803-012	LSU temperature KM	-	-
5-803-013	LSU temperature CY	-	-
5-803-014	Developer temperature	-	-
5-803-018	IPU Version	-	-
5-803-104	SDCU Set	Set	Not set

### Output Check Table (SP5-804, SP5-805)

Activates the electrical components for functional check.

It is not possible to activate more than one component at the same time.

SP	Display
5-804-001	CTLFAN Motor
5-804-101	FAN:LSU
5-804-102	FAN:BELT
5-804-103	FAN:ALL
5-804-202	Scanner Lamp

## 3.SP Mode Tables

SP	Display
5-805-003	Eraser Disconnect
5-805-004	Dev Recovery
5-805-005	Calib R
5-805-006	LSU Clean Direc
5-805-007	LSU Clean Time
5-805-008	LSU Clean
5-805-009	TonerMotorDrive
5-805-010	TrayPaperQuan
5-805-011	TrayPaperQuanSts
5-805-012	Dev Recovery R
5-805-013	Registration
5-805-014	Registration R