

2000/3000 SHEET FINISHER B700/B701

REVISION HISTORY		
Page	Date	Added/Updated/New
		None

What This Manual Contains

This manual describes two finishers, the 2000-Sheet Finisher Booklet (B700) and 3000-Sheet Finisher (B701):

- Replacement and Adjustment
- Details

For details about installation, preventive maintenance, troubleshooting, and specifications please refer to the Service Manual for the Venus-C1a/C1b (Machine Code: B132/B181/B200).

2000-Sheet Booklet Finisher B700

This finisher is equipped with three trays: a proof tray on top of the finisher, an upper (shift) tray, and a lower tray for booklets.

3000-Sheet Finisher B701

This finisher is equipped with two trays: a proof tray on top of the finisher and the upper (shift) tray. This finisher does corner stapling only. It does not have the lower tray of the B700 for stapled and folded booklets.

NOTE: The descriptions in this manual apply to both finishers. Where differences between these two finishers exist, you will see the notations "B700 only" or "B701 only".

1. REPLACEMENT AND ADJUSTMENT

1.1 BASIC PROCEDURES

1.1.1 COVERS

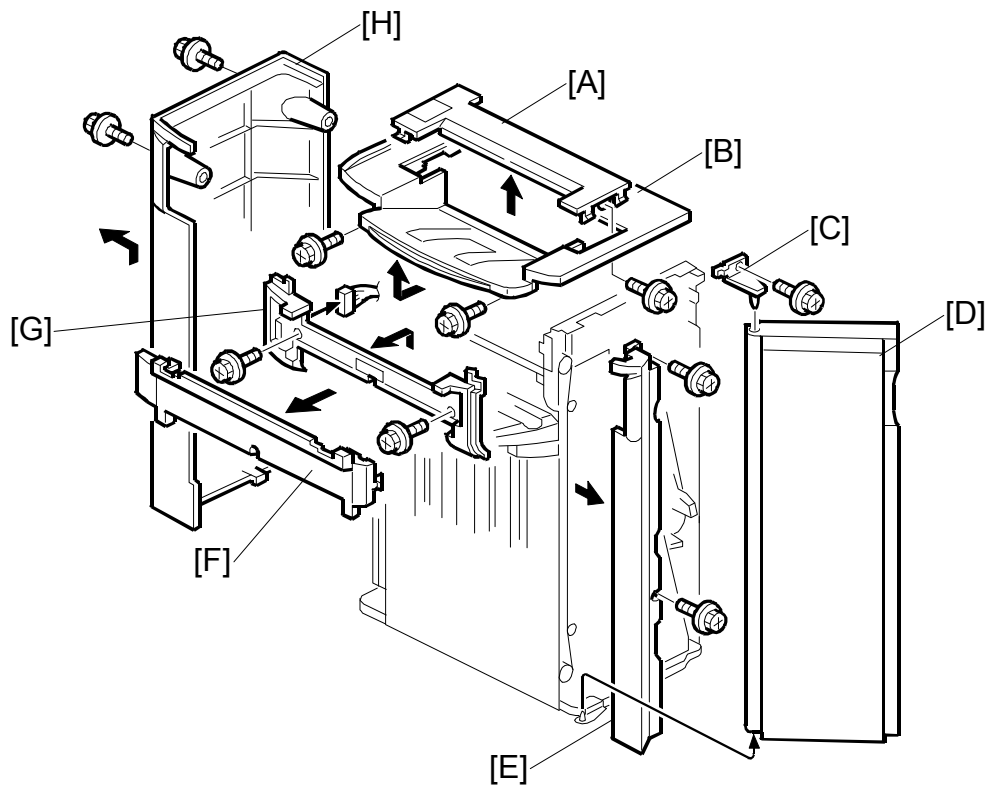

- [A]: Small Upper Cover (🔩 x1). Open the front door, remove the screw, then remove the cover.
- [B]: Upper Cover (🔩 x2)
- [C]: Front Door Bracket (🔩 x1)
- [D]: Front Door
- [E]: Front Left Side Cover (🔩 x2)
- [F]: Cover
- [G]: Paper Exit Cover (🔩 x2)
- [H]: Rear Cover (🔩 x2)

2000/3000
 Sheet
 Finisher
 B700/B701

1.1.2 UPPER TRAY, END FENCE

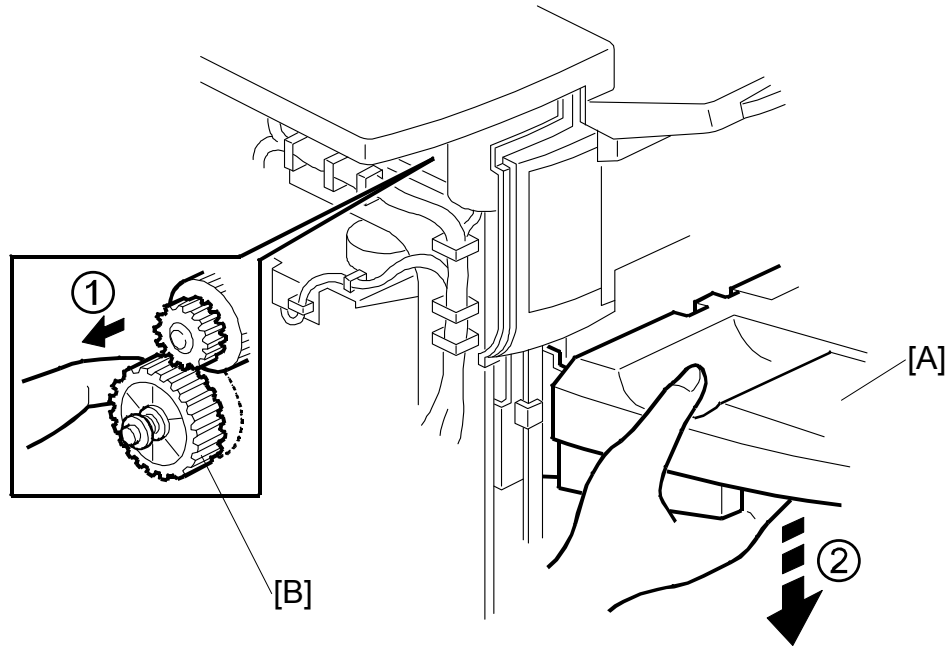

1. Remove the rear cover. (☛1.1.1)
2. To lower the upper tray:
 - Support the tray [A] with your right hand.
 - Pull gear [B] toward you ① to release.
 - Slowly lower the tray ② until it stops.

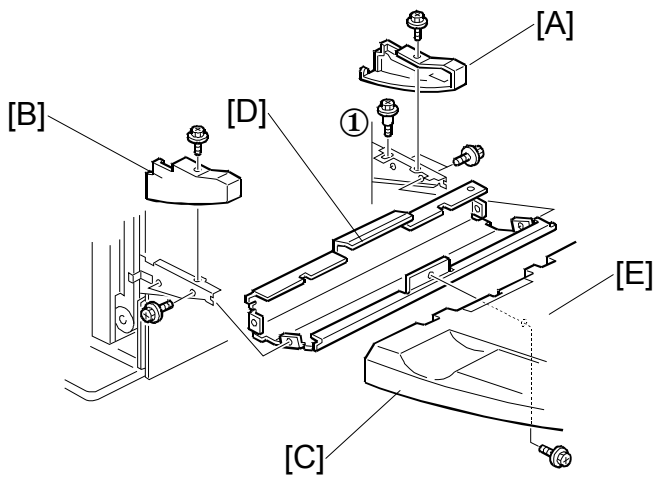

- [A]: Front Side Cover (⌘ x1)
- [B]: Rear Side Cover (⌘ x1)
- [C]: Upper Tray (⌘ x1)
- [D]: Tray Bracket (⌘ x4, ⌘ x1 shoulder screw ①)
- [E]: End Fence (⌘ x3)

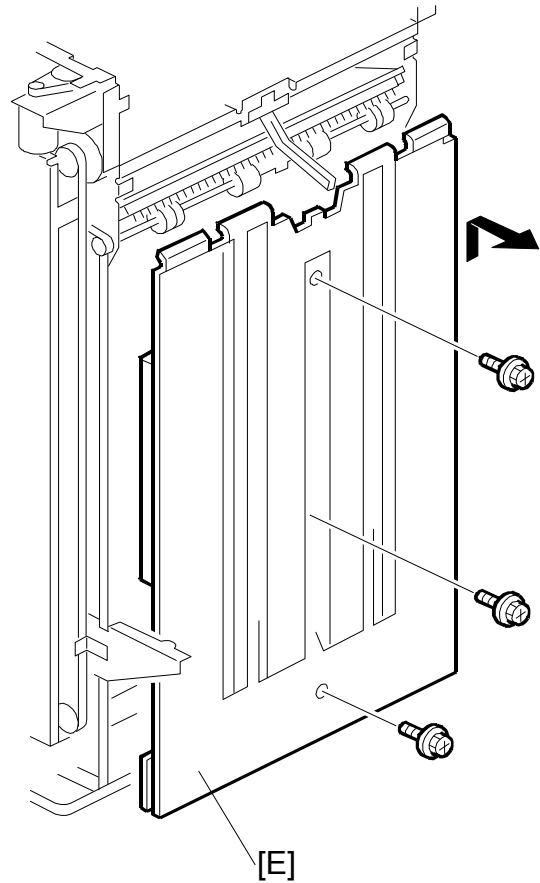

2000/3000
Sheet
Finisher
B700/B701

1.2 UPPER TRAY LIMIT SENSOR, LIMIT SWITCH

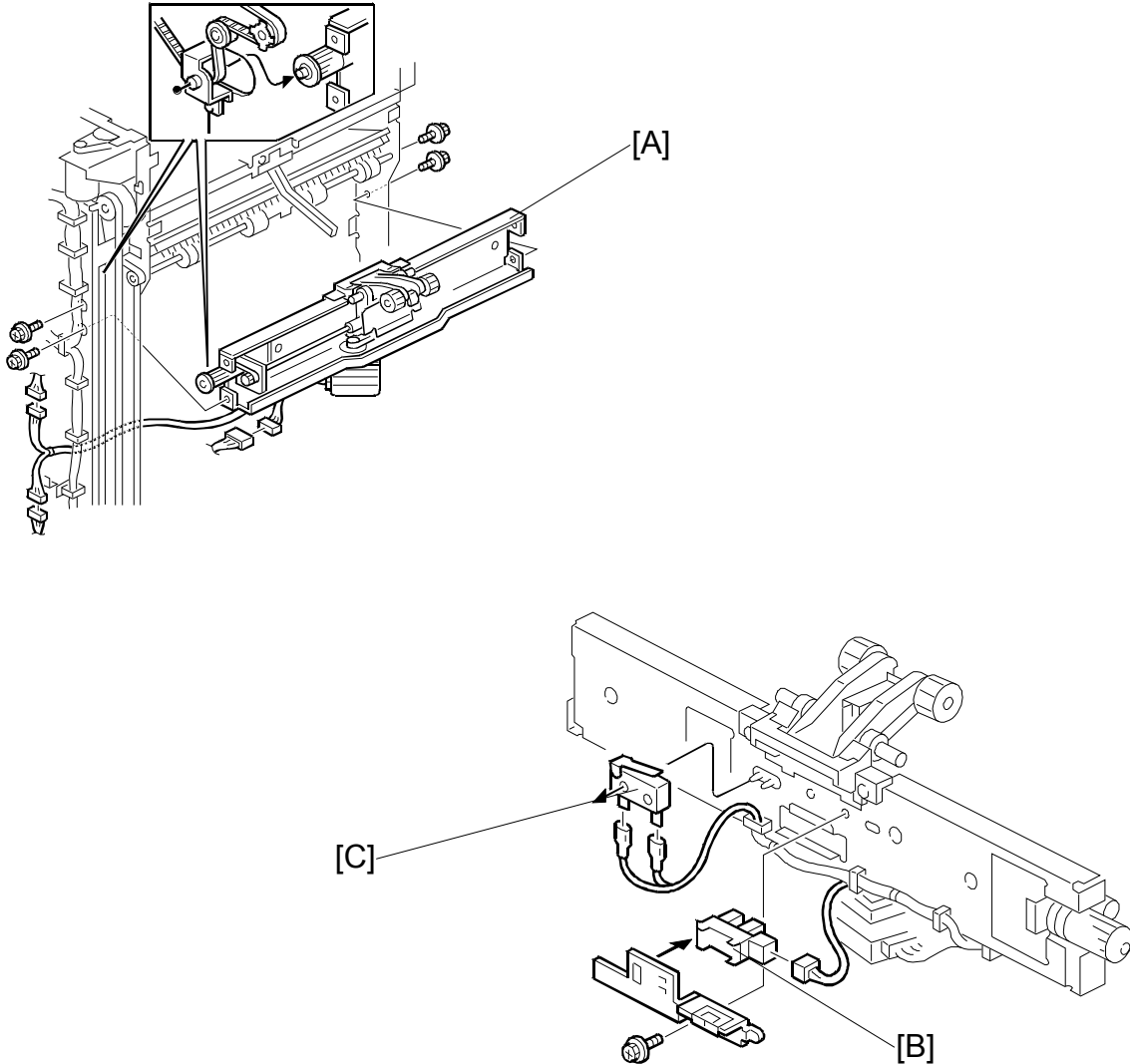

Remove:

- Front door, front left side cover, rear cover, upper cover (☛1.1.1)
- End fence (☛1.1.2)

[A]: Upper tray exit mechanism (🔩 x4, 🛠️ x3)

[B]: Upper tray limit sensor (🔩 x1, 🛠️ x1)

[C]: Upper tray limit switch (🛠️ x2)

1.3 POSITIONING ROLLER

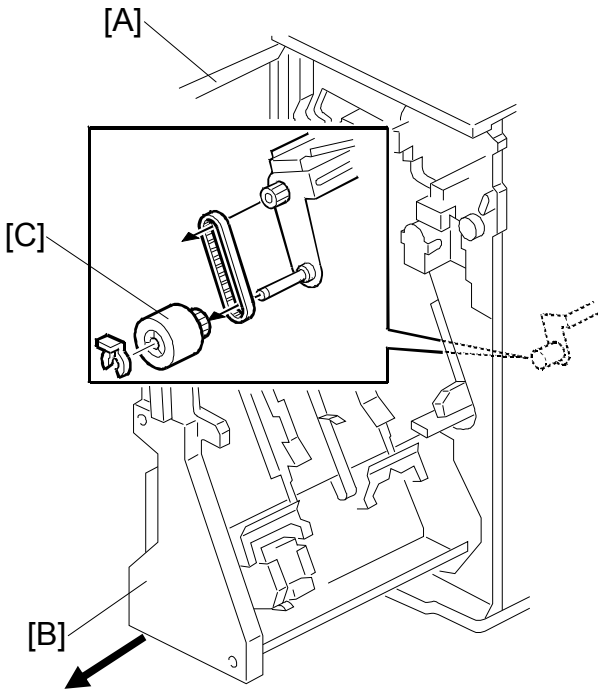

- [A]: Open the front door.
- [B]: Pull out the stapling unit.
- [C]: Positioning roller (⌀ x1, timing belt x1)

2000/3000
Sheet
Finisher
B700/B701

1.4 PROOF TRAY EXIT SENSOR

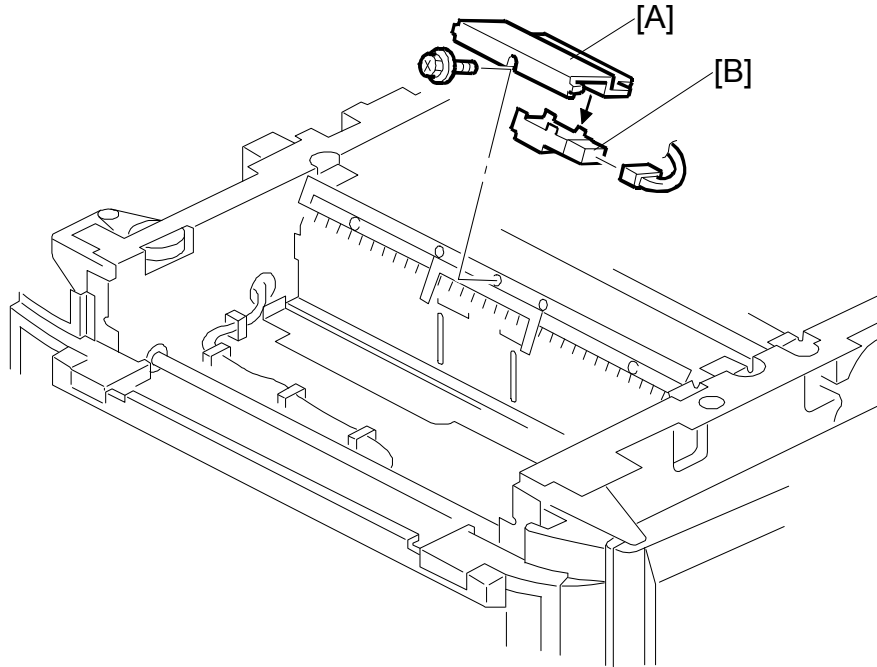

- Remove small upper cover (☛1.1.1)
- [A]: Proof Tray Exit Sensor Bracket (🔩 x1)
- [B]: Proof Tray Exit Sensor (S10) (🔌 x1)

1.5 UPPER TRAY HEIGHT SENSORS 1, 2

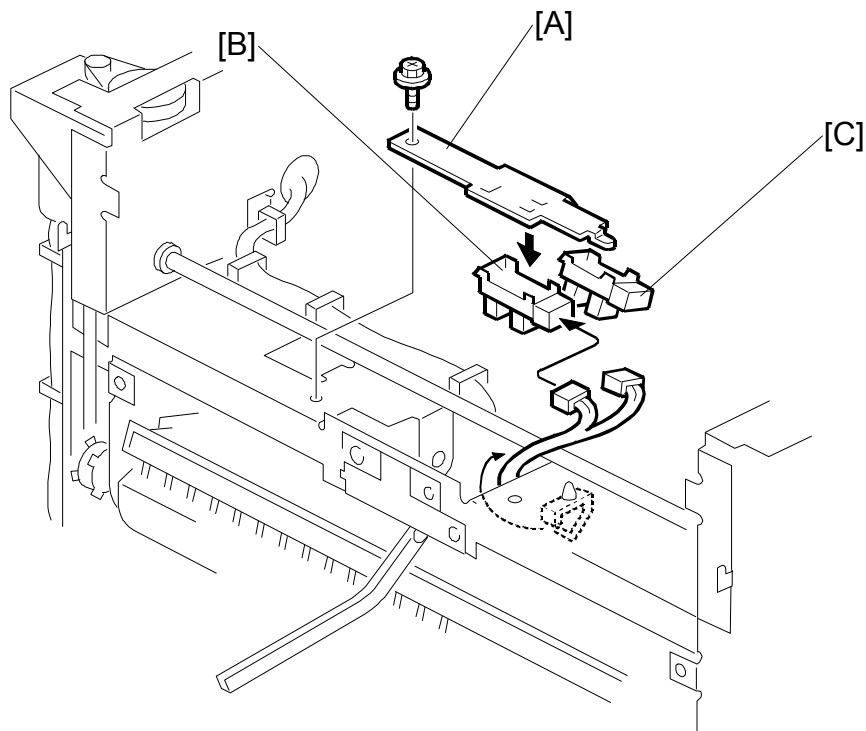

2000/3000
Sheet
Finisher
B700/B701

- Remove small upper cover, upper cover (➡1.1.1)
- [A]: Upper Tray Paper Height Sensor Bracket (🔩 x1)
- [B]: Upper Tray Paper Height Sensor – Staple Mode (S08) (📏 x1)
- [C]: Upper Tray Paper Height Sensor – Non-Staple Mode (S09) (📏 x1)

1.6 EXIT GUIDE PLATE, UPPER TRAY EXIT SENSOR

Remove:

- Rear cover (☞1.1.1)
- Upper covers (☞1.1.1)
- Front door (☞1.1.1)
- Cover (☞1.1.1)
- Paper exit cover (☞1.1.1)

[A]: Inner cover (🔩 x2)

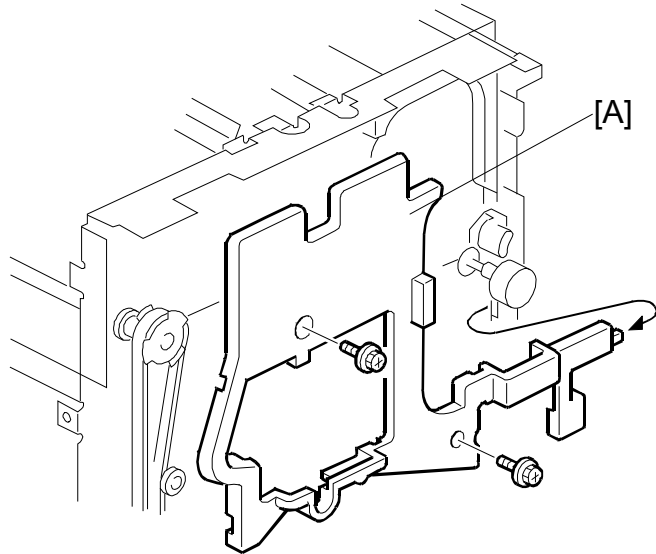

[B]: Exit guide plate

- ① 🌀 x1
- ② Link and spring
- ③ 📡 x1
- ④ 🌀 x1

[C]: Upper tray exit sensor (S6)
(📡 x1)

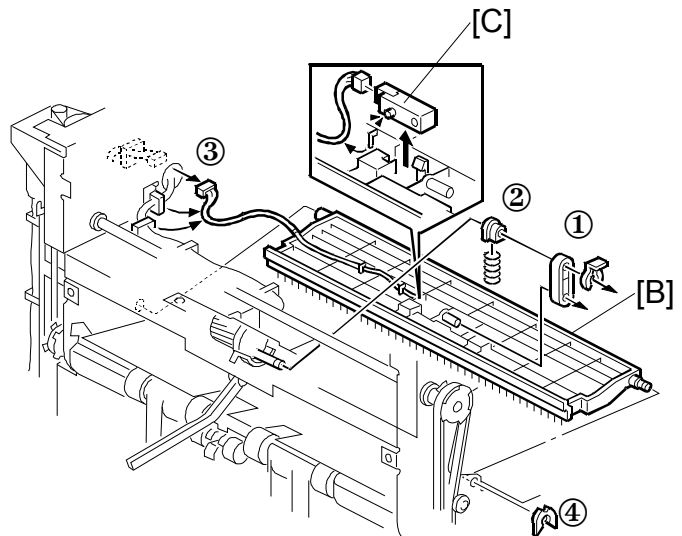

1.7 PROOF TRAY FULL SENSOR

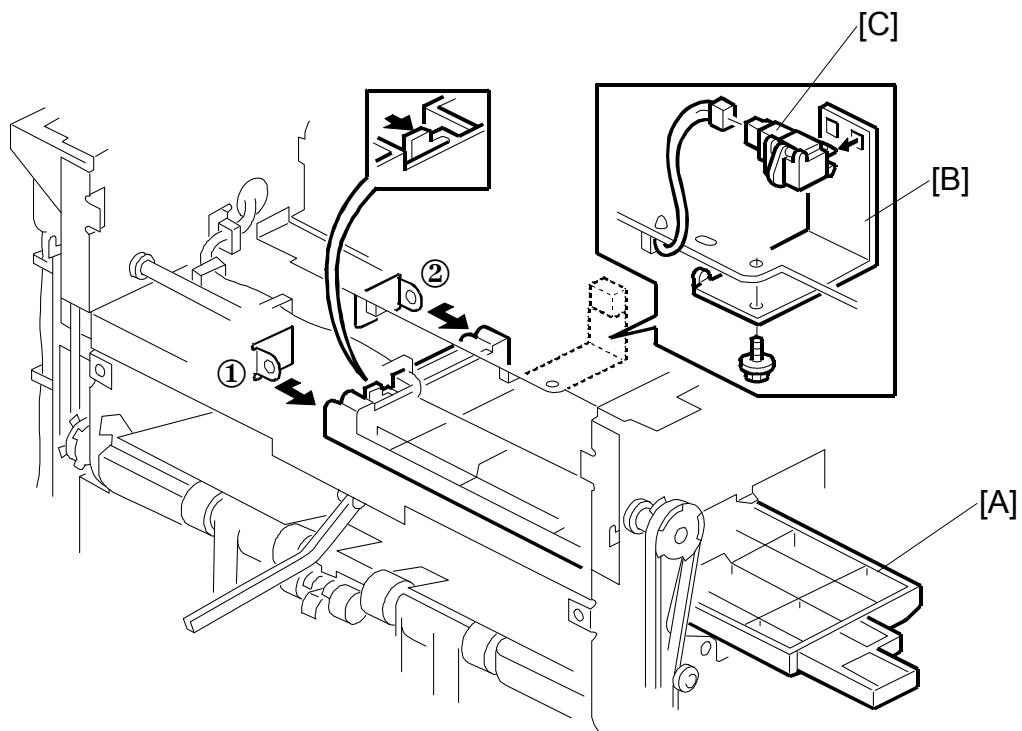

- Remove the exit guide plate. (☞1.6)
- [A]: Guide plate. Disconnect at ①, ②
- [B]: Sensor bracket (🔩 x1)
- [C]: Proof tray full sensor (S11) (🔌 x1)

2000/3000
Sheet
Finisher
B700/B701

1.8 FINISHER ENTRANCE SENSOR

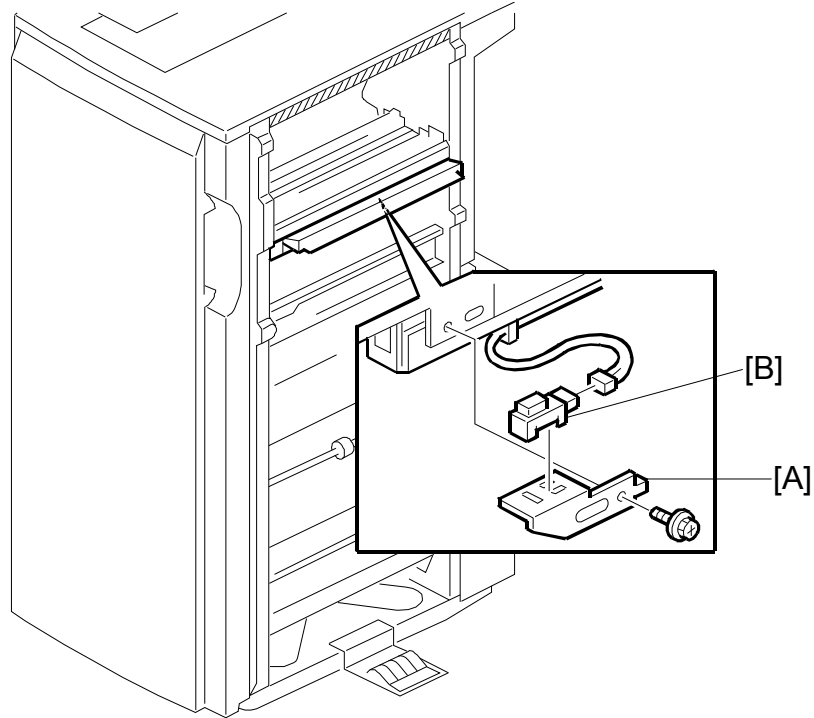

- Disconnect the finisher if it is connected to the copier.
- Disconnect the cover interposer if it is installed.

[A]: Sensor bracket (🔩 x1)

[B]: Finisher entrance sensor (S1) (🔌 x1)

1.9 PRE-STACK TRAY EXIT SENSOR

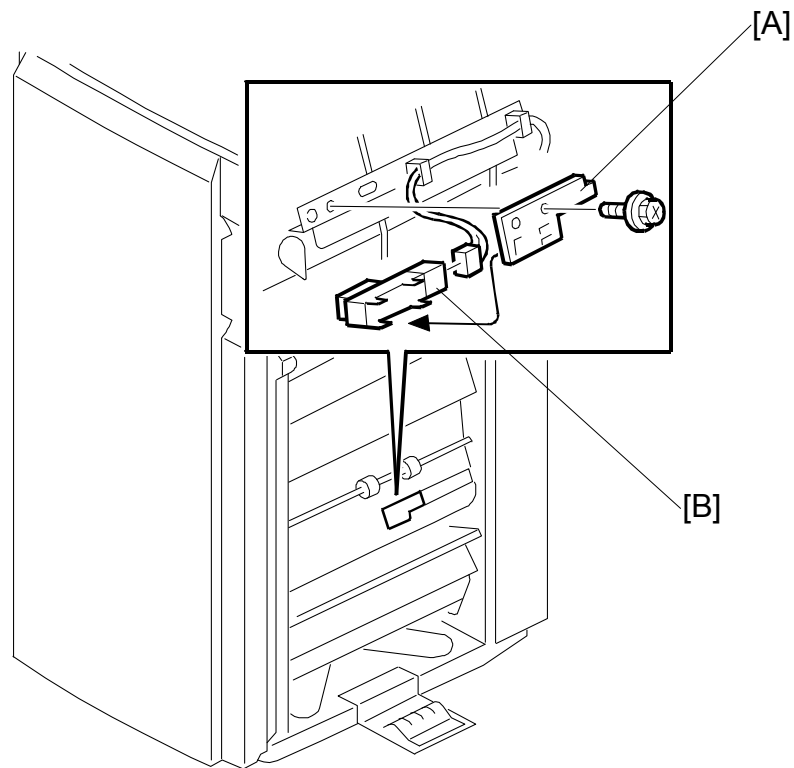

- Disconnect the finisher if it is connected to the copier.
- [A]: Sensor bracket
[B]: Pre-stack tray exit sensor (S2)

2000/3000
Sheet
Finisher
B700/B701

1.10 FOLD UNIT EXIT SENSOR

- Open the front door.
- Pull out the stapler tray.

[A]: Fold unit vertical guide plate

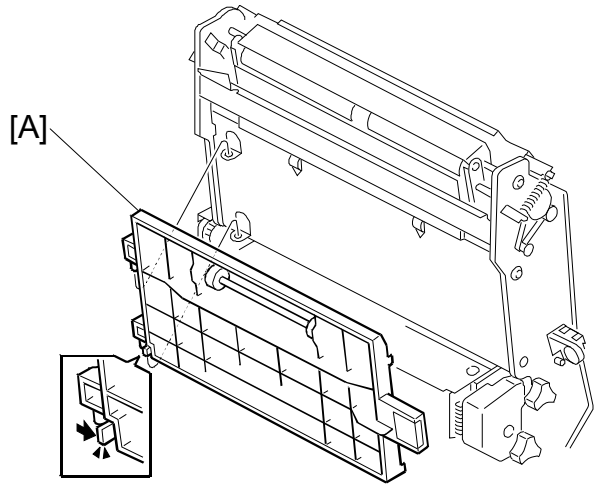

[B]: Fold unit inner cover
( x2, Spring pin x1)

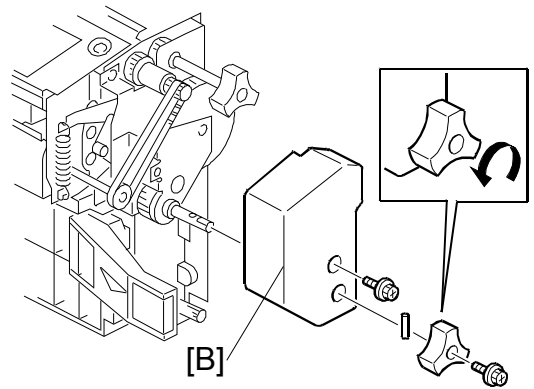

[C]: Fold unit upper cover ( x1)

[D]: Paper clamp mechanism ( x4)

[E]: Fold unit exit sensor bracket ( x1)

[F]: Fold unit exit sensor (S31) ( x1)

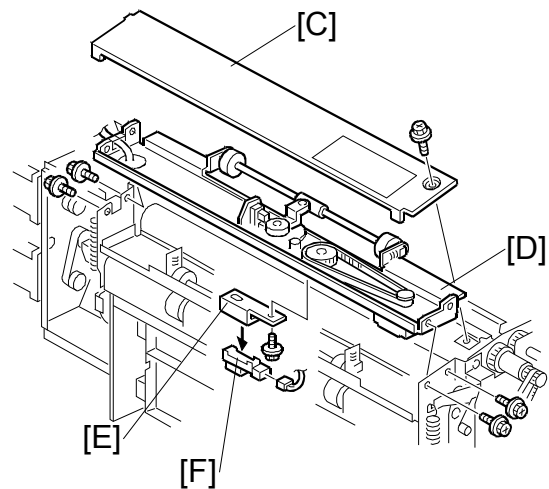

1.11 FOLD ADJUSTMENTS (B700 ONLY)

1.11.1 FOLDING HORIZONTAL SKEW ADJUSTMENT

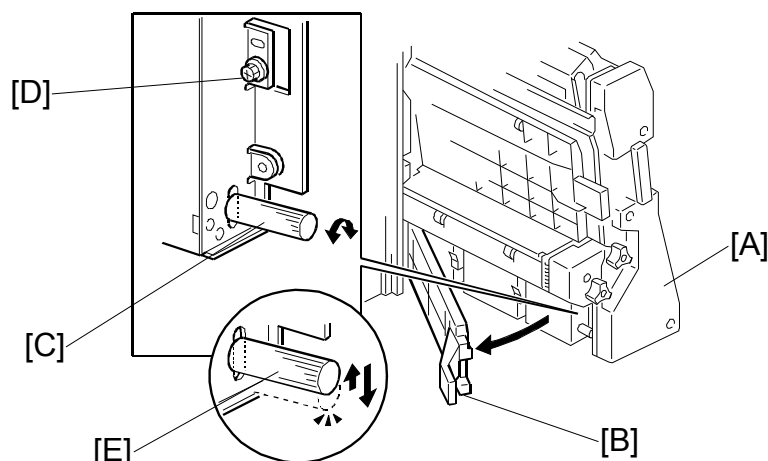

Important

- The fold unit is adjusted for optimum performance before the finisher is shipped from the factory. Do this adjustment only if the edges of folded booklets are not even.

1. Switch the copier on and enter the SP mode.
2. Europe, Asia: Use **SP 6113 001** (this is for A3 paper).
North America: Use **SP 6113 005** (this is for DLT paper).
NOTE: If the original setting of SP6113 001 or 005 is not 0, then you must do the vertical skew adjustment (➔1.11.2) after you finish this horizontal skew procedure.
3. Use the 10-key pad to input "-2" (mm) for the SP value.
NOTE: (Press [·/*] to enter the minus sign.)
4. Press [#] then exit the SP mode.
5. Open the front door and pull the stapler unit [A] out of the finisher.
6. Open the guide plate [B].
7. Loosen the adjustment screw [C] and then tighten until it stops. (Do not over tighten.)
8. Remove the lock screw [D].
9. Raise the tip [E] of the adjustment screw very slightly and allow it to descend under its own weight.

FOLD ADJUSTMENTS (B700 ONLY)

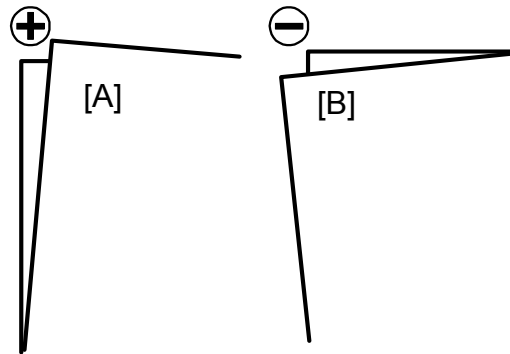

10. Push the stapler unit into the finisher and close the front door.
11. Do a folding test.
 - Switch the copier on.
 - Put one page of A3 or DLT paper in the ARDF.
 - On the copier operation panel, select booklet stapling.
 - Press [Start]. One sheet is folded.
12. Remove the sheet from the lower tray.
13. Hold the folded sheet with the creased side pointing down and face-up (the same way that it came out of the finisher).
14. Referring to the diagram, determine if the skew is **+** [A] or **-** [B].

FOLD ADJUSTMENTS (B700 ONLY)

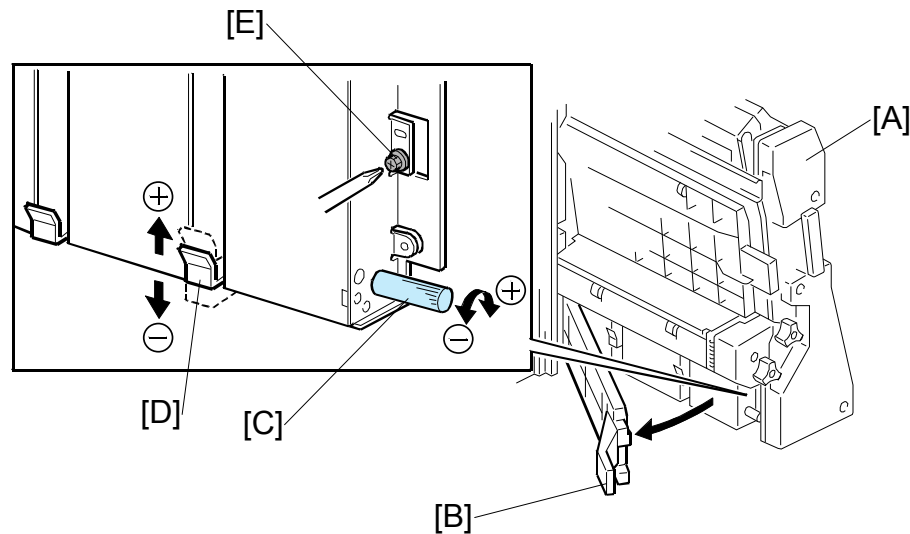

15. Open the front door of the finisher and pull the stapler unit [A] out.
16. Open the guide plate [B].
17. Turn the adjustment screw [C] to correct the amount of skew you measured from the test sheet.
 - For **+ skew ([A] on the previous page)**, turn the adjustment screw (clockwise).
 - For **- skew ([B] on the previous page)**, turn the adjustment screw to the left (counter-clockwise).
 - Every click in the +/- direction adjusts the fold position by 0.1 mm by moving the bottom fence [D]
18. Raise the tip of the adjustment screw [C] and allow it to lower under its own weight.
19. Attach and tighten the lock screw [E].
20. Push the stapler unit into the machine, close the front door, then turn the copier on.
21. Europe, Asia: Do **SP 6113 001** (this is for A3 paper).
North America: Do **SP 6113 005** (this is for DLT paper).
22. Reset it to "0".
23. Do the test again.
24. If the result is satisfactory, this completes the adjustment.
-or-
If some skew remains, repeat this adjustment.
NOTE: After doing this adjustment, adjust for vertical skew, if necessary. (☛1.11.2).

1.11.2 FOLD VERTICAL SKEW ADJUSTMENT

Important

- The fold unit is adjusted for optimum performance before the finisher is shipped from the factory. Do this adjustment only if the edges of folded booklets are not even.

- Switch the copier on.
- Do a folding test.
 - Switch the copier on.
 - Put one page of A3 or DLT paper in the ARDF.
 - On the copier operation panel, select booklet stapling.
 - Press [Start]. One sheet is folded.

- Hold the folded sheet with the creased side pointing down, and face-up (the same way that it came out of the finisher).

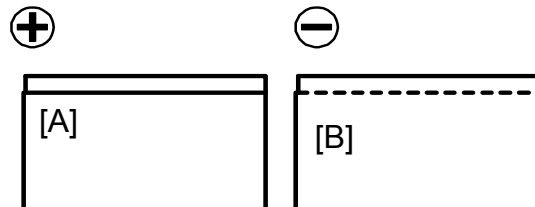

- Referring to the diagram, determine if the skew is positive [A] or negative [B].

- Measure the amount of skew.

- Enter the SP mode

- Europe, Asia: Use **SP 6113 001** (this is for A3 paper).
- North America: Use **SP 6113 005** (this is for DLT paper).

- Enter one-half the measured amount of skew.

Example: If the measure amount of skew is -1.2 mm, enter -0.6 mm

NOTE: The range for measurement is -3.0 mm to +3.0 mm in 0.2 mm steps for every notch adjustment.

- Exit the SP mode and do the test again (steps 2 to 5).

- Repeat this procedure until the skew is corrected.

The illustration below shows the effects of +/- adjustment with **SP6113**. (The vertical arrows show the direction of paper feed.)

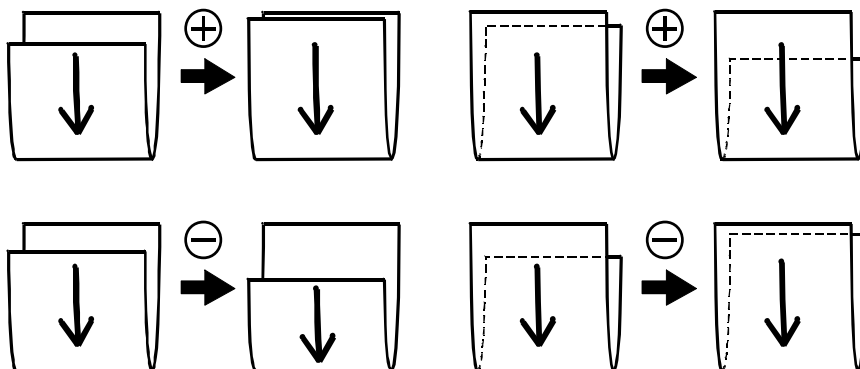

1.12 CORNER STAPLER

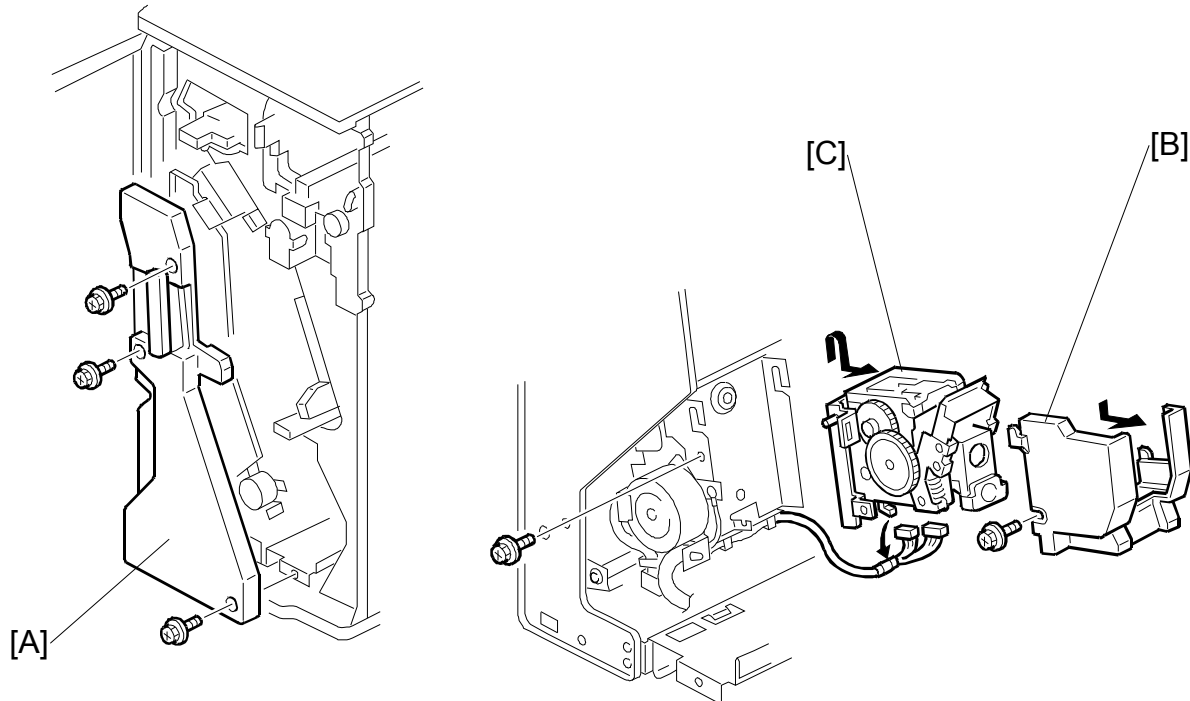

- Open the front door.
 - Pull out the stapler unit
- [A]: Inner cover (🔩 x3)
 [B]: Stapler unit holder (🔩 x1)
 [C]: Corner stapler (M20) (🔩 x1)

2000/3000
 Sheet
 Finisher
 B700/B701

1.13 FOLD UNIT

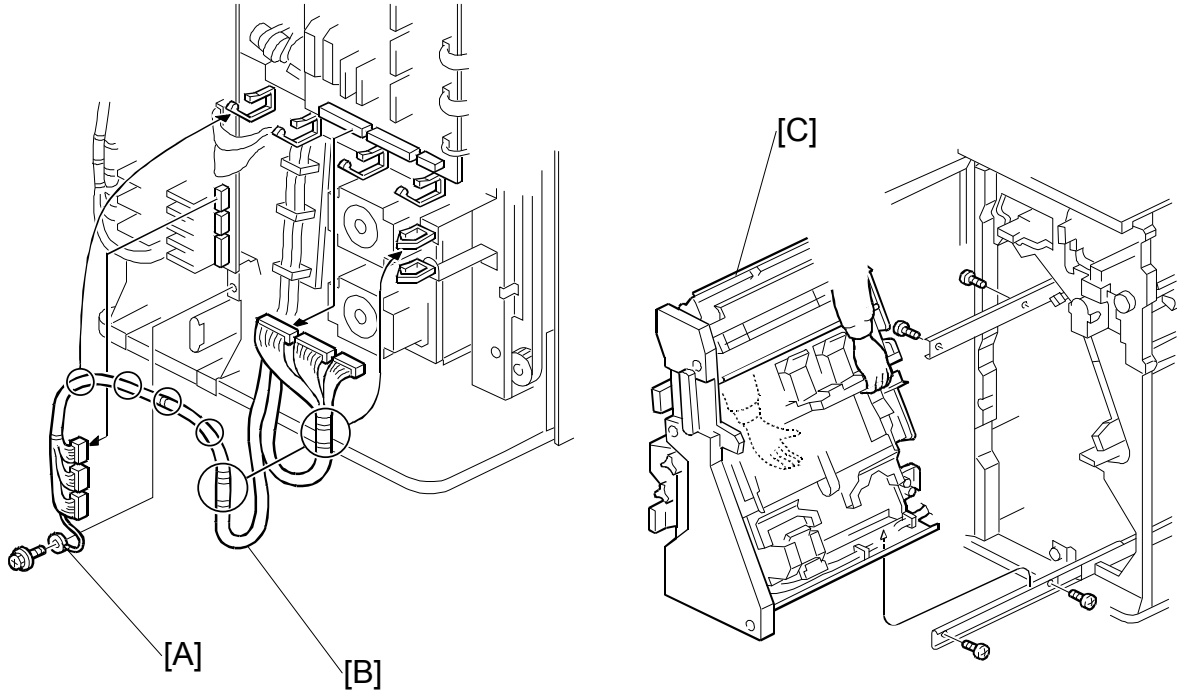

- Remove the back cover (➔1.1.1)
- Open the front door.

CAUTION: The stapler unit is heavy.

- [A]: Ground screw (🔩 x1)
[B]: Harness (🔌 x6, 📡 x6)
[C]: Stapler unit (🔩 x4)

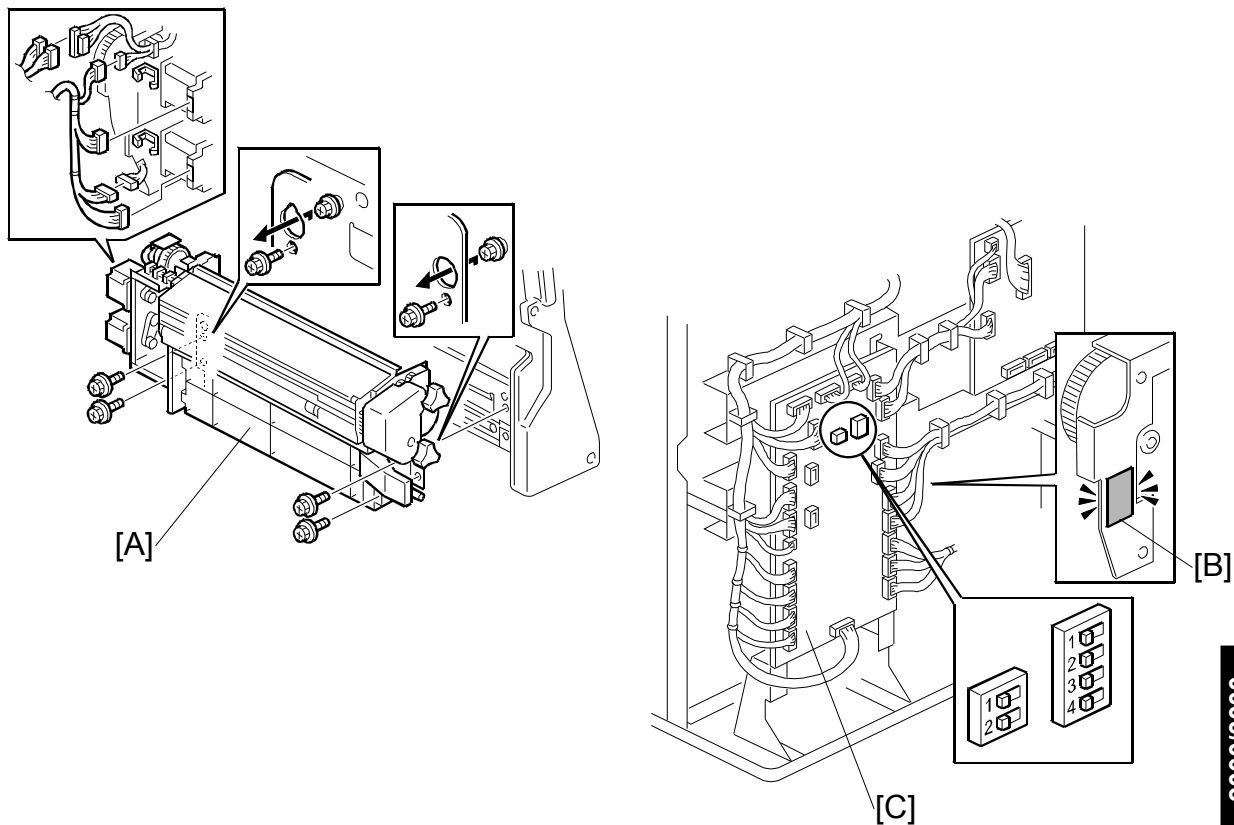

2000/3000
Sheet
Finisher
B700/B701

Important: Support the fold unit with your hand to prevent it from falling.

CAUTION: The fold unit is heavy.

[A]: Folding unit (⚙️ x4, 🛠️ x2, 📏 x6)

If you have replaced the folding unit:

1. Read the DIP SW settings on the decal [B] attached to the back of the new folding unit.
2. Check the DIP SW settings on the main board [C] of the finisher.
3. If these settings are different, change these settings to match settings printed on the seal attached to the folding unit.

NOTE: Set DIP switches 1 to 4 (the switch set on the right). Do not touch the other DIP switches.

1.14 FOLD UNIT ENTRANCE SENSOR

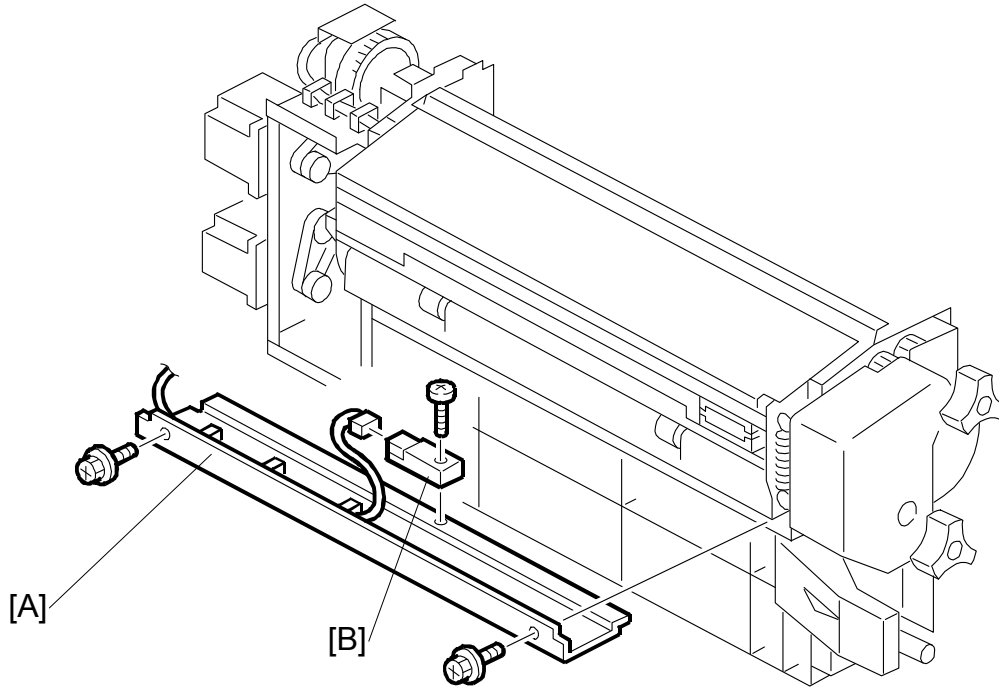

- Pull out the stapler unit.

[A]: Fold unit entrance sensor bracket (🔩 x2)

[B]: Fold unit entrance sensor (S26) (🔩 x1, 📏 x1)

1.15 STACK PRESENT SENSOR

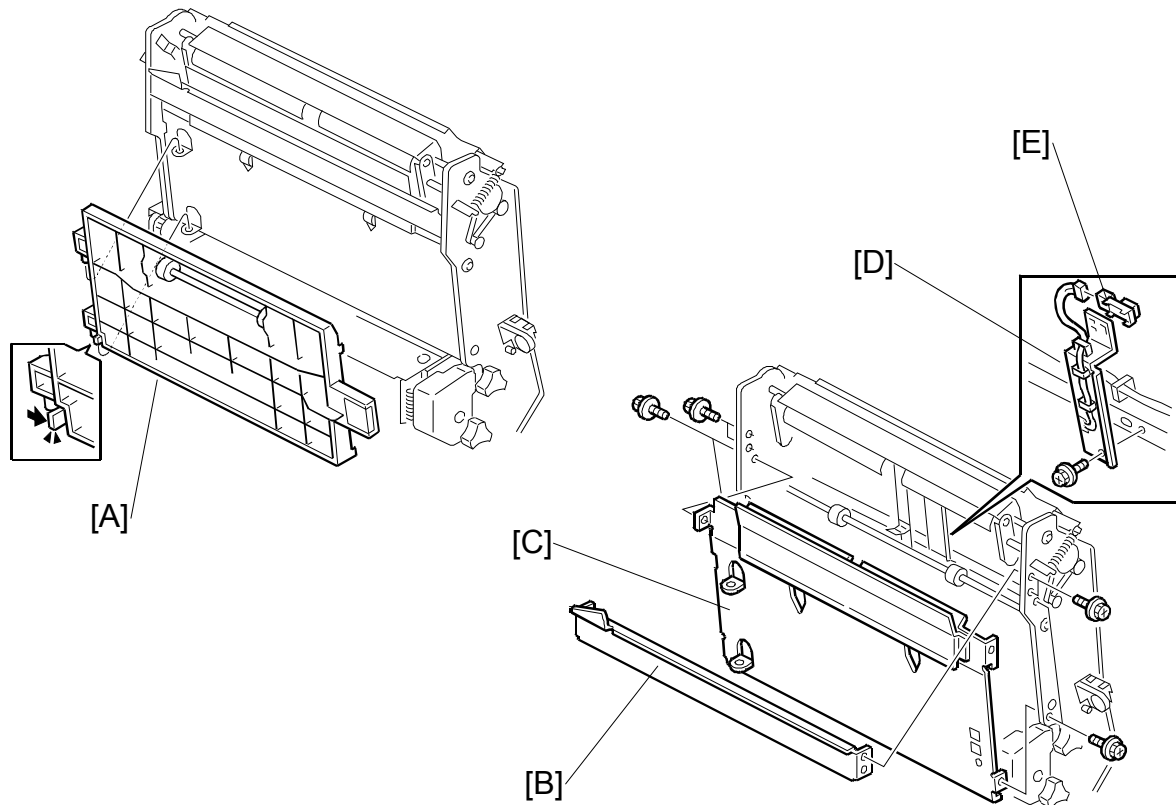

2000/3000
Sheet
Finisher
B700/B701

Important: If you intend to correct the horizontal and vertical skew for the fold unit at the same time, do those adjustments first, then replace the sensor. (☛1.11.1, 1.11.2)

- Remove the stapler unit (☛1.13)

[A]: Guide plate.

[B]: Stay (🔩 x4)

[C]: Left plate (🔩 x4)

[D]: Sensor bracket (🔩 x1)

[E]: Stack present sensor (S32) (🔩 x1)

1.16 BOOKLET STAPLER, BOOKLET STAPLER MOTOR

1.16.1 BOOKLET STAPLER

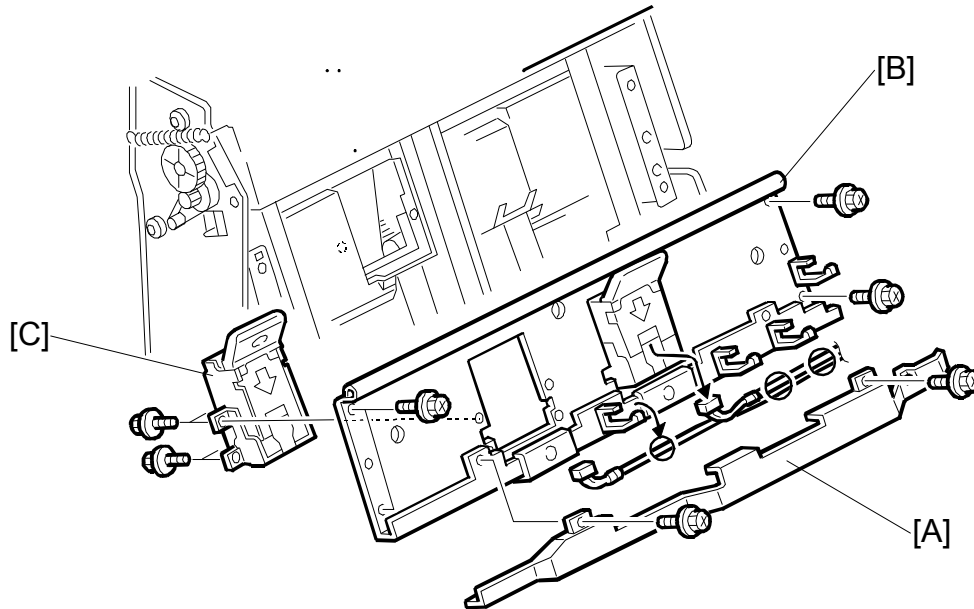

- Open the front door.
 - Pull out the stapler unit.
- [A]: Harness cover (🔩 x2)
[B]: Booklet stapler support stay (🔩 x4, 📌 x2, 📌 x4)
[C]: Stapler (🔩 x4)

1.16.2 BOOKLET STAPLER MOTOR

- Open the front door.
- Remove the stapler unit. (➔1.13)

1. Remove:

[A]: Stay (🔩 x4).

[B]: Left plate (🔩 x4).

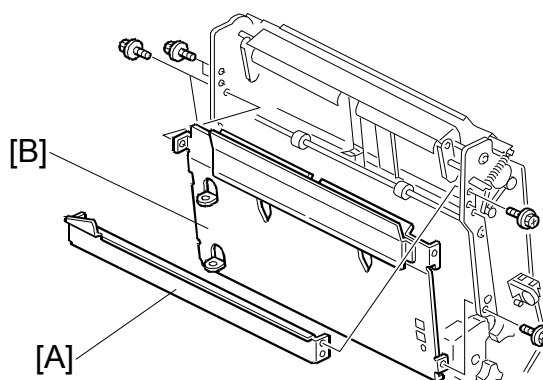

2. Remove:

[C]: Harness cover (🔩 x2)

[D]: Booklet stapler support stay
(🔩 x4, 🛠️ x2, 🛠️ x4)

[E]: Booklet stapler (🔩 x4)

[F]: Booklet stapler motor (🔩 x2, 🛠️ x1)

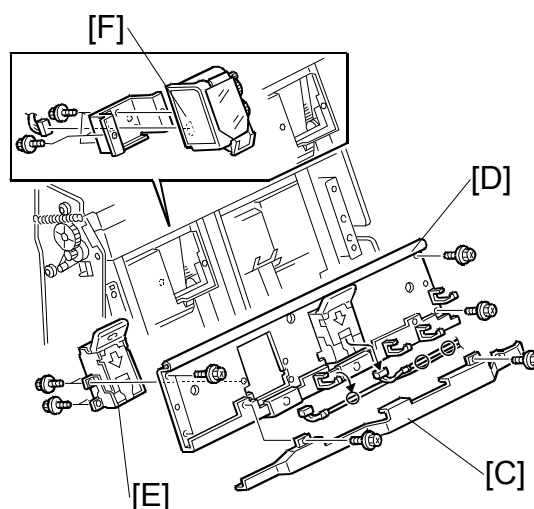

To Reattach the Booklet Stapler Motor

3. Reattach the booklet stapler motor.
Important: Do not tighten the screws.

4. Attach the special tool [G] and reattach the booklet stapler stay.
NOTE: This tool is included with the stapler spare part.

NOTE: This tool is included with the stapler spare part.

5. Turn the gear [H] with your finger until it stops.
6. Tighten the screws to attach to the booklet stapler motor.
7. Remove the stay again and remove the special tool.
8. Reattach the booklet stapler stay.
9. Push the stapler unit into the machine.

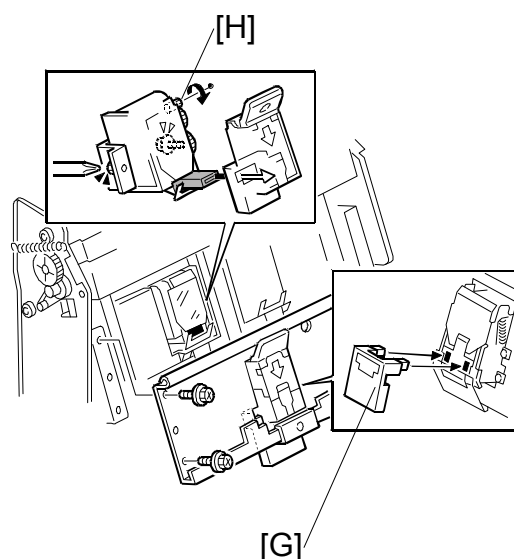

2000/3000
Sheet
Finisher
B700/B701

2. DETAILS

2.1 GENERAL LAYOUT

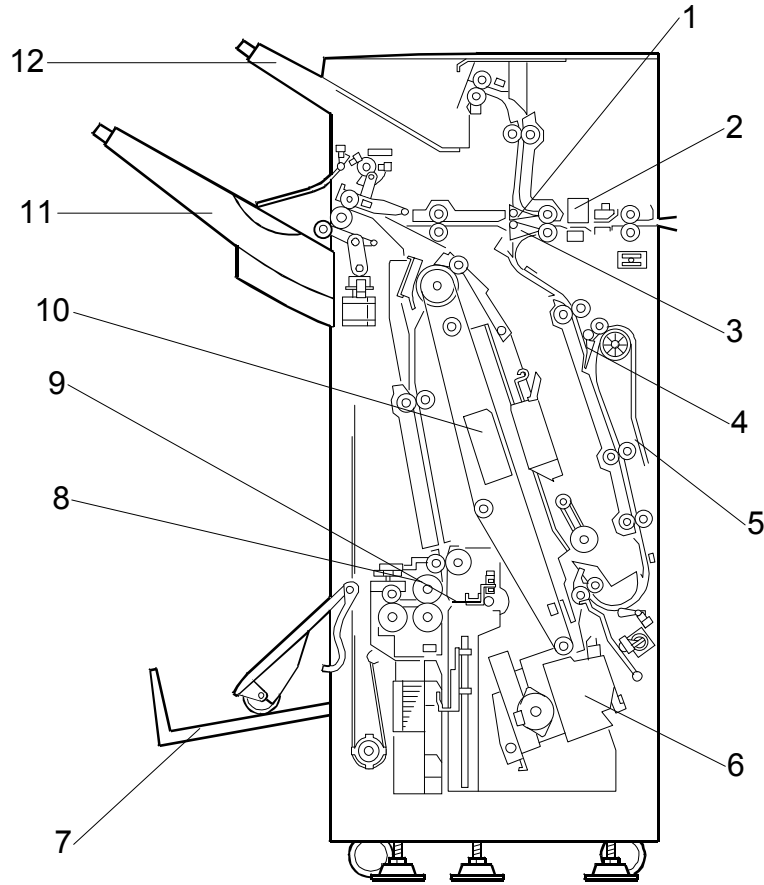

- | | |
|-----------------------------|---------------------------|
| 1. Proof Tray Junction Gate | 7. Lower Tray (Booklet)*1 |
| 2. Punch Unit | 8. Folder Rollers*1 |
| 3. Stapler Junction Gate | 9. Folder Plate*1 |
| 4. Pre-Stack Junction Gate | 10. Booklet Stapler*1 |
| 5. Pre-Stack Tray | 11. Upper Tray (Shift) |
| 6. Corner Stapler (M20) | 12. Proof Tray |

*1 **B700 Only**

Paper direction

The operation of the proof tray and stapler junction gates direct the flow of the paper once it enters the finisher:

Proof Junction Gate	Stapler Junction Gate	Paper Feeds
Closed	Closed	Paper feeds straight through
Open	Closed	Paper feeds to the proof tray
Closed	Open	Paper feeds to the staple tray

Proof tray

Copies are sent to the proof tray (12) when neither sorting nor stapling are selected for the job.

Upper tray

The upper tray (11) receives copies that are sorted and shifted and also receives copies that have been corner stapled. Corner stapling is provided on both the B700 and the B701.

Pre-stack tray

The pre-stack tray has a switchback mechanism to increase the productivity of stapling. (☛2.5) Pre-stacking is done for corner stapling in the B700/B701 and for booklet stapling in the B700.

Lower tray

The lower tray (7) receives copies that have been center folded and stapled (booklet stapling). Booklet stapling is not provided on the B701.

2.2 ELECTRICAL COMPONENTS

2.2.1 UPPER AREA B700/B701

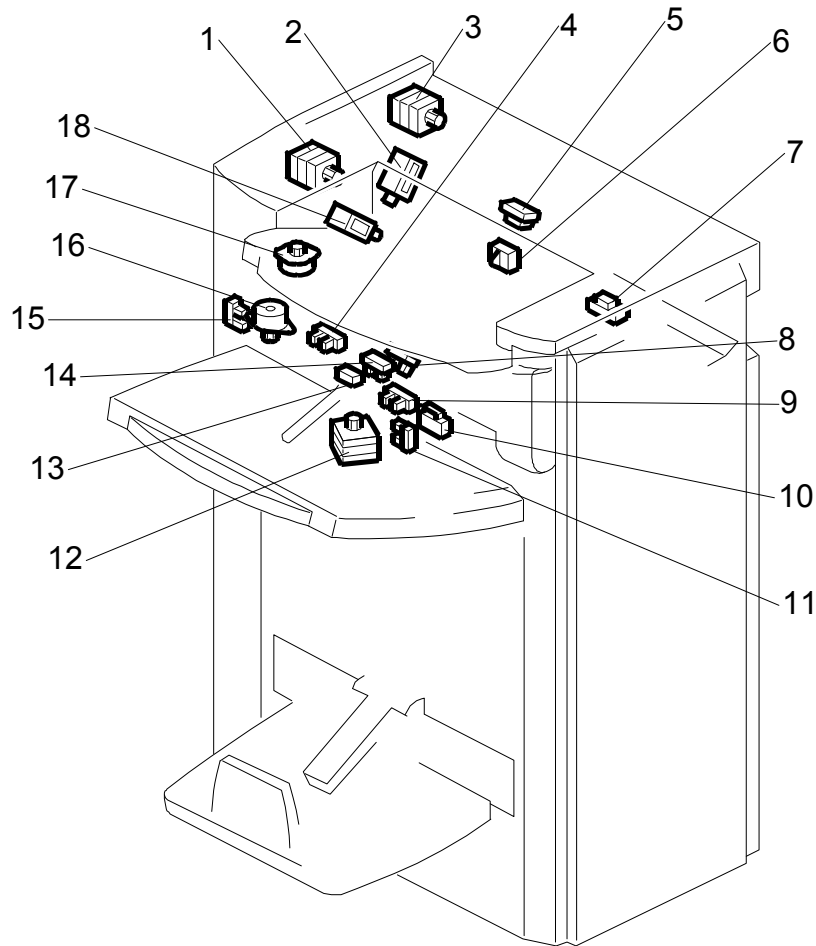

- | | |
|--|--|
| 1. Upper/Proof Exit Motor (M4) | 10. Upper Tray Limit Switch (SW2) |
| 2. Stapling Tray Junction Gate Solenoid (SOL2) | 11. Stacking Roller HP Sensor (S13) |
| 3. Upper Transport Motor (M2) | 12. Stacking Sponge Roller Motor (M10) |
| 4. Exit Guide Plate HP Sensor (S7) | 13. Upper Tray Exit Sensor (S6) |
| 5. Proof Tray Exit Sensor (S10) | 14. Upper Tray Paper Height Sensor (S8)
(Staple Mode) |
| 6. Proof Tray Full Sensor (S11) | 15. Shift Roller HP Sensor (S5) |
| 7. Finisher Entrance Sensor (S1) | 16. Shift Roller Motor (M18) |
| 8. Upper Tray Paper Height Sensor (S9) (Non-
Staple Mode) | 17. Exit Guide Plate Motor (M19) |
| 9. Upper Tray Limit Sensor (S12) | 18. Proof Junction Gate Solenoid (SOL1) |

2.2.2 LOWER AREA B700/B701

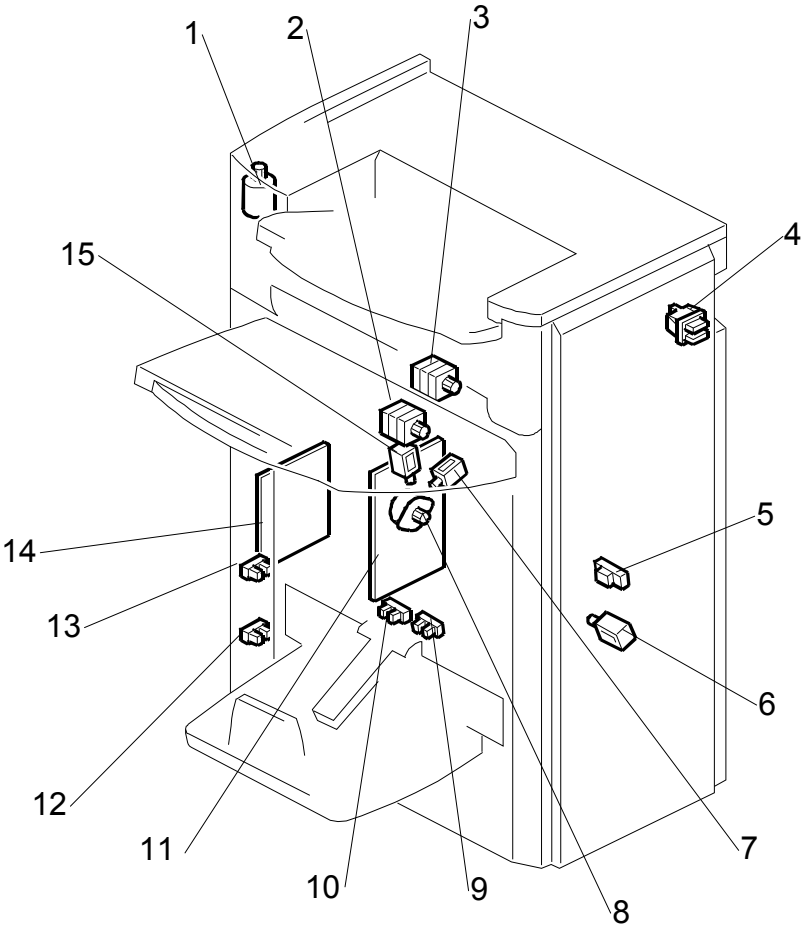

2000/3000
Sheet
Finisher
B700/B701

- 1. Upper Tray Lift Motor (M21)
- 2. Lower Transport Motor (M3)
- 3. Entrance Motor (M1)
- 4. Front Door Safety Switch (SW1)
- 5. Pre-Stack Tray Exit Sensor (S2)
- 6. Stapling Edge Pressure Plate Solenoid (SOL4)
- 7. Positioning Roller Solenoid (SOL3)
- 8. Positioning Roller Motor (M14)
- 9. Lower Tray Full Sensor – Front (S34)*1
- 10. Lower Tray Full Sensor – Rear (S33)*1
- 11. Main Board (PCB1)
- 12. Upper Tray Full Sensor – (S20) *2
- 13. Upper Tray Full Sensor – (S19)
- 14. Booklet Stapler Board (PCB2)*1
- 15. Booklet Pressure Roller Solenoid – (SOL5) *1

*1 B700 Only

*2 B701 Only

2.2.3 PUNCH UNIT B702

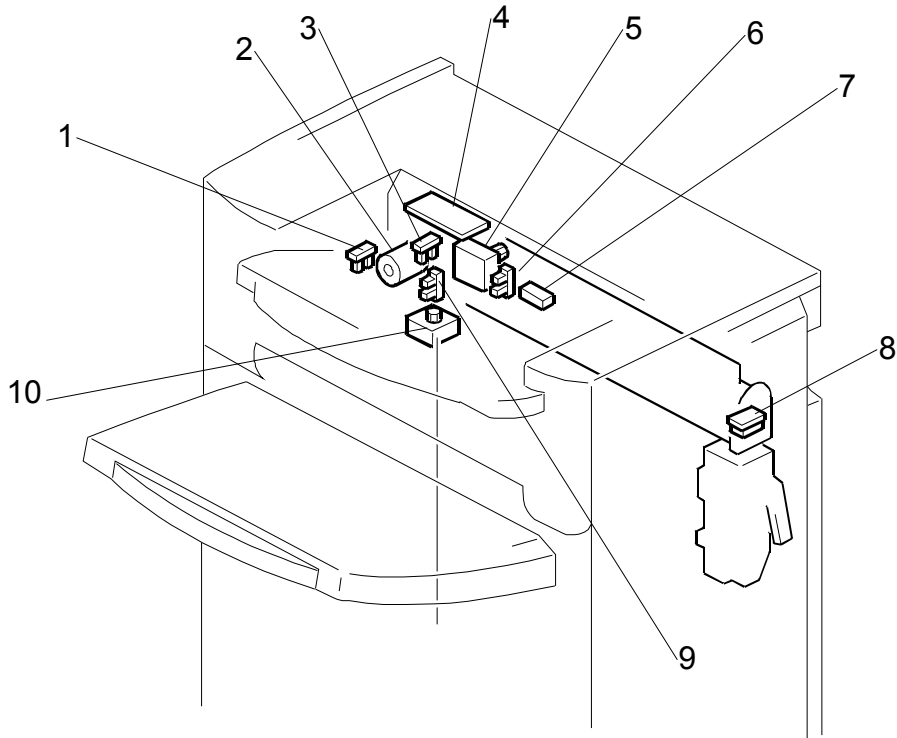

- | | |
|---|---|
| 1. Punch Encoder Sensor (S24) | 6. Paper Position Slide HP Sensor (S22) |
| 2. Punch Drive Motor (M24) | 7. Paper Position Sensor (S3) |
| 3. Punch HP Sensor (S24) | 8. Punch Hopper Full Sensor (S4) |
| 4. Punch Unit Board (PCB3) | 9. Punch Movement HP Sensor (S21) |
| 5. Paper position sensor slide motor (M7) | 10. Punch Movement Motor (M9) |

2.2.4 STACKER/STAPLER - B700/B701

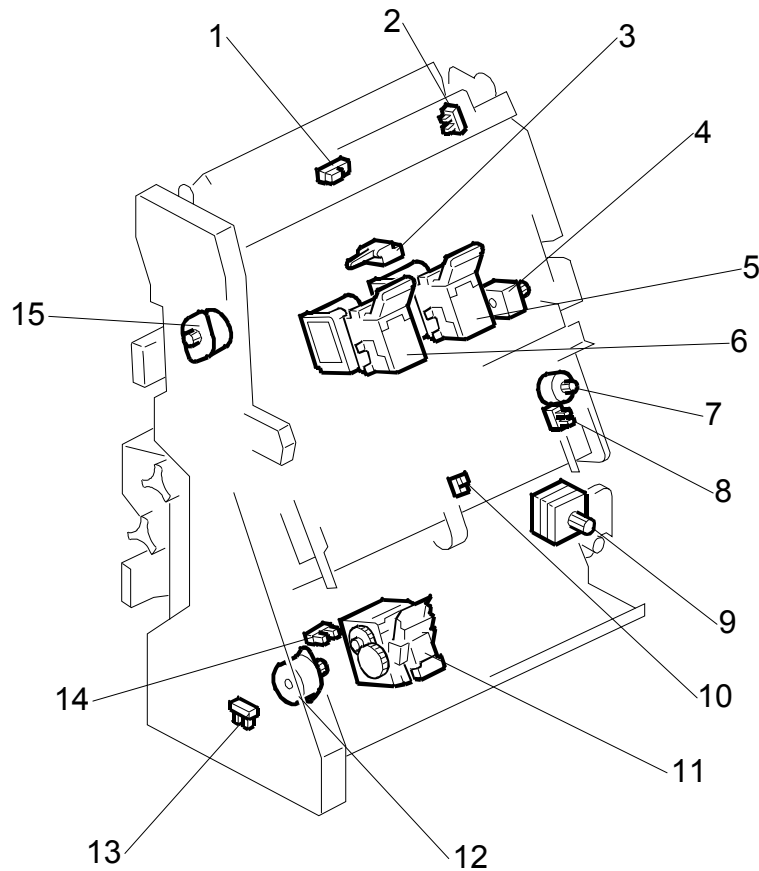

- | | |
|---|--|
| 1. Stack Present Sensor (S32)* ¹ | 9. Corner Stapler Movement Motor (M6) |
| 2. Stack Junction Gate HP Sensor (S27)* ¹ | 10. Stapling Tray Paper Sensor (S14) |
| 3. Stack Feed Out Belt HP Sensor (S16) | 11. Corner Stapler EH530 (M20) |
| 4. Feed Out Belt Motor (M5) | 12. Corner Stapler Rotation Motor (M13) |
| 5. Booklet Stapler EH185R – Rear (M23)* ¹ | 13. Corner Stapler HP Sensor (S17) |
| 6. Booklet Stapler EH185R – Front (M22)* ¹ | 14. Stapler Rotation HP Sensor (S18) |
| 7. Jogger Fence Motor (M15) | 15. Stack Junction Gate Motor (M17) * ¹ |
| 8. Jogger Fence HP Sensor (S15) | |

*¹ **B700 Only**

2.2.5 B700 FOLD UNIT

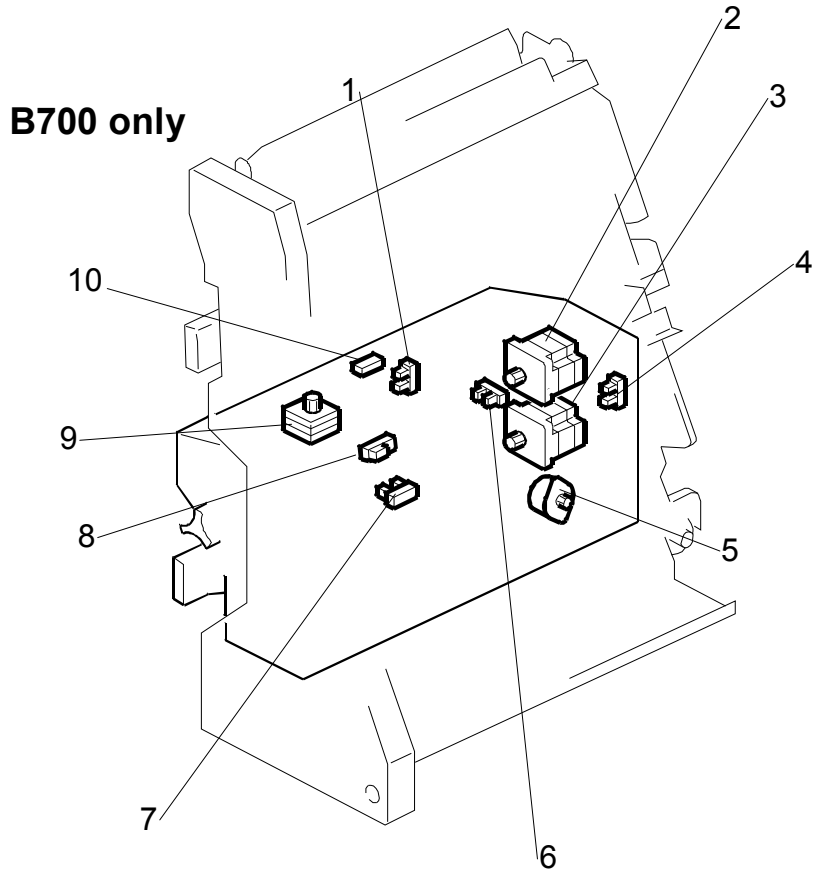

- | | |
|--|---------------------------------------|
| 1. Clamp Roller HP Sensor (S25) | 6. Fold Cam HP Sensor (S30) |
| 2. Fold Roller Motor (M12) | 7. Fold Bottom Fence HP Sensor (S28) |
| 3. Fold Plate Motor (M11) | 8. Fold Unit Entrance Sensor (S26) |
| 4. Fold Plate HP Sensor (S29) | 9. Clamp Roller Retraction Motor (M8) |
| 5. Fold Unit Bottom Fence Lift Motor (M16) | 10. Fold Unit Exit Sensor (S31) |

2.2.6 SUMMARY OF ELECTRICAL COMPONENTS

Here is a general summary of all the electrical components of the B700/B701 finishers.

NOTE: In the table below a number that appears in bold text (**M8**, etc.) denotes a component that is on the 2000/3000 Sheet Finisher B700 only.

No.	Component	Function
Boards (PCB)		
PCB1	Main Board	The main board that controls the finisher
PCB2	Booklet Stapler Board	A separate board that controls booklet finishing.
PCB3	Punch Unit Board	The board that controls the punch unit.
Motors		
M1	Finisher Entrance Motor	Drives 1) the finisher entrance rollers, 2) and the punch waste transport belt of the punch unit.
M2	Upper Transport Motor	Drives the paper feed rollers that feed paper 1) to the proof tray, 2) straight-through to the upper tray, 3) the pre-stack tray entrance roller.
M3	Lower Transport Motor	Drives paper feed rollers forward and reverse in the pre-stack tray for the switchback, and drives the other rollers in the lower transport area.
M4	Upper/Proof Tray Exit Motor	Drives 1) proof tray exit rollers, 2) extension and retraction of the stacking sponge roller, 3) upper tray exit rollers.
M5	Feed Out Belt Motor	Drives the feed out belt that moves the stapled stacks out of the stapling tray after stapling.
M6	Corner Stapler Movement Motor	Moves the corner stapler horizontally on a steel rod to position the stapler at the stapling position at 1) the front, 2) the rear (straight stapling), 3) the rear (diagonal stapling), or 4) the front and rear for double stapling.
M7	Paper Position Sensor Slide Motor	Drives the movement of the paper position slide that holds the paper position sensor (S3) that detects the position of the paper.
M8	Clamp Roller Retraction Motor	Drives a large cam that alternately clamps and unclamps the clamp retraction roller, the idle roller of the clamp roller pair. When these rollers are clamped, they are part of the paper feed path and feed the stack toward the bottom fence of the fold unit. When the idle roller is retracted, the stacks falls a very short distance (3 mm) onto the fold unit bottom fence below. These rollers remain unclamped while the bottom fence positions the stack for folding and while the stack is folded by the fold rollers.
M9	Punch Movement Motor	Drives the front/back movement of the punch unit to position it correctly for stapling the paper below.
M10	Stacking Sponge Roller Motor	<u>Rotates</u> the stacking roller that drags each sheet back against the end fence to jog the bottom of each sheet after feed out to the upper tray.
M11	Fold Plate Motor	Drives the fold plate that pushes the center of the stack into the nip of the fold rollers to start the fold.
M12	Fold Roller Motor	Rotates forward and drives the fold rollers that fold the stack and feed it out of the fold unit, reverses to feed the fold once more into the fold unit, and then rotates forward again to feed the fold out of the fold unit.

2000/3000
Sheet
Finisher
B700/B701

ELECTRICAL COMPONENTS

No.	Component	Function
M13	Corner Stapler Rotation Motor	Swivels the corner stapler and positions it so the staple fires at an oblique angle at the rear corner of the paper stack.
M14	Positioning Roller Motor	Drives the positioning roller in the stapling tray.
M15	Jogger Fence Motor	Drives the jogger fences in the stapling tray to jog both sides of the stack before stapling.
M16	Fold Unit Bottom Fence Lift Motor	Raises the bottom fence and stops when the center of the vertical stack is opposite the edge of the horizontal fold blade. The distance for raising the blade is prescribed as one-half the size of the paper selected for the job. For large paper, (A3, B4) the bottom fence first lowers the stack 10 mm below the fold position, and then raises it to the fold position.
M17	Stack Junction Gate Motor	Drives the large cam that operates the <u>stack junction gate</u> at the top of the stapling tray. When this gate is open, it directs the ascending stack to the upper tray if it has been corner stapled, or if it is closed the gate turns the booklet stapled stack down so it falls onto the bottom fence of the folding unit.
M18	Shift Roller Motor	Drives the shift roller that operates in shift mode to stagger document sets as they feed out to the upper tray (making them easier to separate).
M19	Exit Guide Plate Motor	Drives the mechanism that raises and lowers the exit guide plate.
M20	Corner Stapler EH530	This is the roving corner stapler, mounted on a steel rail that staples 1) at the front, 2) at the rear (straight staple), 3) at the rear (diagonal staple), and 4) front and rear (two staples).
M21	Upper Tray Lift Motor	Raises and lowers the upper tray during feed out to keep the tray at the optimum height until it is full.
M22	Booklet Stapler EH185R: Front	Booklet stapler. Staples paper stacks in the center before they are folded.
M23	Booklet Stapler EH185R: Rear	Booklet stapler. Staples paper stacks in the center before they are folded.
M24	Punch Drive Motor	Fires the punches that punch the holes in the paper.
Sensors		
S1	Finisher Entrance Sensor	Provides two functions: (1) Detects paper entering the finisher from the copier, and (2) Signals a jam if it detects paper at the entrance when the copier is switched on.
S2	Pre-stack Tray Exit Sensor	Detects 1) paper fed from the pre-stack tray to the stapling tray, and detects 2) paper in the pre-stack when the copier is switched on. (This sensor performs no timing function. The entire flow of paper through the pre-stacking mechanism is controlled by motor pulse counts.)
S3	Paper Position Sensor	The photosensor that detects the <u>edge of the paper</u> and sends this information to the punch unit board where it is used to position the punch for punching the holes in the paper.
S4	Punch Hopper Full Sensor	1) A photosensor that detects and signals that the punch hopper is filled with punch waste and needs emptying, and 2) confirms the presence of the punch hopper and signals an error if it is missing or not installed completely.
S5	Shift Roller HP Sensor	Located near the shift roller motor, controls the front-to-back movement of the shift roller as shifts paper during straight-through feed.
S6	Upper Tray Exit Sensor	A flat, photo sensor located inside the guide plate, detects the leading edge and trailing edge of the paper as it feeds out to the upper tray during straight-through jobs (with and

ELECTRICAL COMPONENTS

No.	Component	Function
		without stapling). When paper is fed to the upper tray, at the paper output slot this sensor signals an error when it detects (1) paper has failed to leave the paper exit (lag error), (2) detects paper has failed to arrive at the paper exit (late error), (3) detects paper is in the exit slot when the machine is turned on.
S7	Exit Guide Plate HP Sensor	Controls the vertical movement of the control exit guide . The guide plate is in the home position when the guide plate is down and the actuator interrupts the sensor gap.
S8	Upper Tray Paper Height Sensor (Staple Mode)	This is the <u>upper</u> sensor of the upper/lower paper height sensor pair that controls the lift of the upper tray. This sensor detects the paper height of the stack in the upper tray when the copier is operating in the staple mode.
S9	Upper Tray Paper Height Sensor (Non-Staple Mode)	This is the <u>lower</u> sensor of the upper/lower paper height sensor pair that controls the lift of the upper tray. When the machine is switched on, the upper tray rises until the actuator on the tray triggers this sensor to switch off the upper tray lift motor.
S10	Proof Tray Exit Sensor	This sensor detects and times the feeding of paper to the proof tray. It also detects whether paper is present at the proof tray exit when the copier is switched on.
S11	Proof Tray Full Sensor	The top of the stack in the proof tray increases until it nudges the feeler of this sensor. The sensor then signals that the proof tray is full and the job halts until some paper is removed from the proof tray.
S12	Upper Tray Limit Sensor	This sensor controls the position of the upper tray 1) during straight-through feed out, 2) during shift feed out, 3) when the machine is turned on. The machine obeys the signal of whichever sensor is actuated first. An actuator attached to an arm triggers this sensor. The tip of the same arm depresses the upper tray limit switch. If the sensor fails, the tip of the arm will activate the upper tray limit microswitch (SW2) and stop the lift of the upper tray. Note: When the machine is turned on, the upper tray position is controlled by either this sensor or the upper tray paper height sensor (S9).
S13	Stacking Roller HP Sensor	Controls the forward and back motion of the stacking roller (a sponge roller) located at the output slot of the upper tray. The sponge roller drags each ejected sheet back against the end fence of the upper tray to keep the bottom of the stack aligned.
S14	Stapling Tray Paper Sensor	A photo sensor that detects whether paper is in the stapling tray. When this sensor detects paper, the bottom fence motor raises or lowers the bottom fence to position the selected paper size for booklet stapling.
S15	Jogger Fence HP Sensor	Detects the home position of the jogger fences. When the actuator on the jogger fence interrupts this sensor, the jogger fence is in its home position and the jogger fence motor (M15) stops.
S16	Stack Feed-Out Belt HP Sensor	Controls the position of the stack feed-out pawl on the stack feed-out belt. Once the actuator on the feed belt nudges the feeler of this sensor near the top of the stapling unit, the feed out belt motor (M5) remains on for the time prescribed to position the pawl at the home position to catch the next stack.
S17	Corner Stapler HP	Located at the front the stapling tray and mounted above the

2000/3000
Sheet
Finisher
B700/B701

ELECTRICAL COMPONENTS

No.	Component	Function
	Sensor	steel rod where the corner stapler travels, this sensor detects the home position of the corner stapler. The corner stapler is in its home position when the actuator on the corner stapler unit interrupts this sensor.
S18	Stapler Rotation HP Sensor	Controls the angle of the position of the corner stapler during oblique stapling.
S19	Upper Tray Full Sensor (B700/B701)	B700: When the actuator on the side of the upper fence enters the gap of this sensor, the sensor signals that the upper tray is at its lowest position (full) and stops the job. B701: One of two upper tray full sensors. This is the higher tray full sensor for A3 and other heavy paper. The other upper tray full sensor (20) is for lighter paper.
S20	Upper Tray Full Sensor (B701 only)	B700: This sensor is not used on the booklet finisher. There is only one upper tray full sensor (S18). B701: One of two upper tray full sensors. This is the lower tray full sensor for A4 and smaller paper. The other upper tray full sensor (19) is for larger paper.
S21	Punch Unit HP Sensor	Switches off the punch movement motor when the punch unit returns to its home position. Pulse counts determine where the punch unit pauses for punching and reversing.
S22	Paper Position Side HP Sensor	Controls the movement of the paper position detection unit. Switches on when the horizontal detection unit is at the home position (HP is the reference point).
S23	Punch HP Sensor	Detects the home position of the punch unit and controls the vertical movement of the punches when they fire.
S24	Punch Encoder Sensor	When the punch mode is selected for the job (2-hole, 3-hole, etc.), the machine controls the operation of the punch drive (M24) motor which drives a small encoder shaped like a notched wheel. This wheel is rotated forward and reverse precisely to select which punches are moved up and down during the punch stroke.
S25	Clamp Roller HP Sensor	Controls the movement of the clamp retraction roller (the idle roller of the clamp roller pair).
S26	Fold Unit Entrance Sensor	Detects 1) the leading edge of the stack during booklet stapling, and 2) also used to signal an alarm if a paper is detected at the entrance of the fold unit when the copier is turned on.
S27	Stack Junction Gate HP Sensor	Controls the opening and closing of the stack junction gate. Switches on when the stack junction gate is open and at the home position.
S28	Fold Bottom Fence HP Sensor	Controls the movement of the bottom fence in the <u>folding</u> unit using pulse counts based on the size of the paper selected for the job to position the stack correctly for feeding.
S29	Fold Plate HP Sensor	Along with the fold plate cam HP sensor (S30) this sensor controls the movement of the fold plate . The fold plate has arrived at the home position when the edge of the plate enters the gap of this sensor.
S30	Fold Plate Cam HP Sensor	Along with the fold plate HP sensor (S29), this sensor controls the movement of the fold plate. The actuator mounted on the end of the roller that drives the folder plate forward and back makes three full rotations, i.e. the actuator passes the sensor gap twice and stops on the 3rd rotation and reverses. This accounts for the left and right movement of fold plate.
S31	Fold Unit Exit Sensor	1) Detects the folded edge of the stack as it feeds out from the nip of the fold rollers, stops the rollers, and reverses them

ELECTRICAL COMPONENTS

No.	Component	Function
		so the fold feeds back into the nip, 2) when the folded booklet finally emerges from the nip of the fold rollers, detects the leading and trailing edge of the booklet to make sure that it feeds out correctly.
S32	Stack Present Sensor	This sensor determines whether there is paper at the turn junction gate when the machine is turned on. If a stack is present, this triggers a jam alert. (This sensor performs no dynamic function such as pulse counting, etc. It only detects whether paper is at the top of the folding unit when power is turned on.)
S33	Lower Tray Full Sensor - Rear	This rear sensor is the <u>lower</u> sensor of the lower tray full sensor pair. Two actuators are attached to the actuator arm that touches the top of stapled and folded booklets as they feed out. The on/off combinations of the two sensors are used to detect when the tray is full and stop the job. (The lower tray is stationary. At tray full, the job halts until booklets are removed from the lower tray.)
S34	Lower Tray Full Sensor - Front	This front sensor is the <u>higher</u> sensor of the lower tray full sensor pair. Two actuators are attached to the actuator arm that touches the top of stapled and folded booklets as they feed out. The on/off combinations of the two sensors are used to detect when the tray is full and stop the job. (The lower tray is stationary. At tray full, the job halts until booklets are removed from the lower tray.)
Solenoids		
SOL1	Proof Junction Gate Solenoid	Opens and closes the proof tray junction gate. When the solenoid switches on, it opens the gate and paper is diverted to the proof tray. When this gate is closed, the paper goes straight to the upper tray.
SOL2	Stapling Tray Junction Gate Solenoid	Directs paper to the stapling tray. When this solenoid is on, paper feeds straight through. When this solenoid is off, paper feeds to the stapler tray below.
SOL3	Positioning Roller Solenoid	Engages the stapler transport motor and the positioning roller of the stapling tray. The positioning roller pushes each sheet down against the bottom fence to align the <u>bottom</u> the stack for stapling. (The jogger fences align the sides.)
SOL4	Stapling Edge Pressure Plate Solenoid	Operates the pressure plate of the stapling unit. The pressure plate presses down the edge of stack in the stapling tray so it is tight for stapling.
SOL5	Booklet Pressure Roller Solenoid	When the paper stack in the stapling tray feeds to the folding unit, this solenoid turns on and operates the roller that pushes on the surface of the stack to flatten it.
Switches		
SW1	Front Door Safety Switch	The safety switch that cuts the dc power when the front door is opened.
SW2	Upper Tray Limit SW	A micro-switch that cuts the power to the upper tray lift motor when the upper tray reaches its upper limit. This switch duplicates the function of the upper tray limit sensor (S12) and stops the upper tray if S12 fails.

2000/3000
Sheet
Finisher
B700/B701

2.3 DRIVE LAYOUT

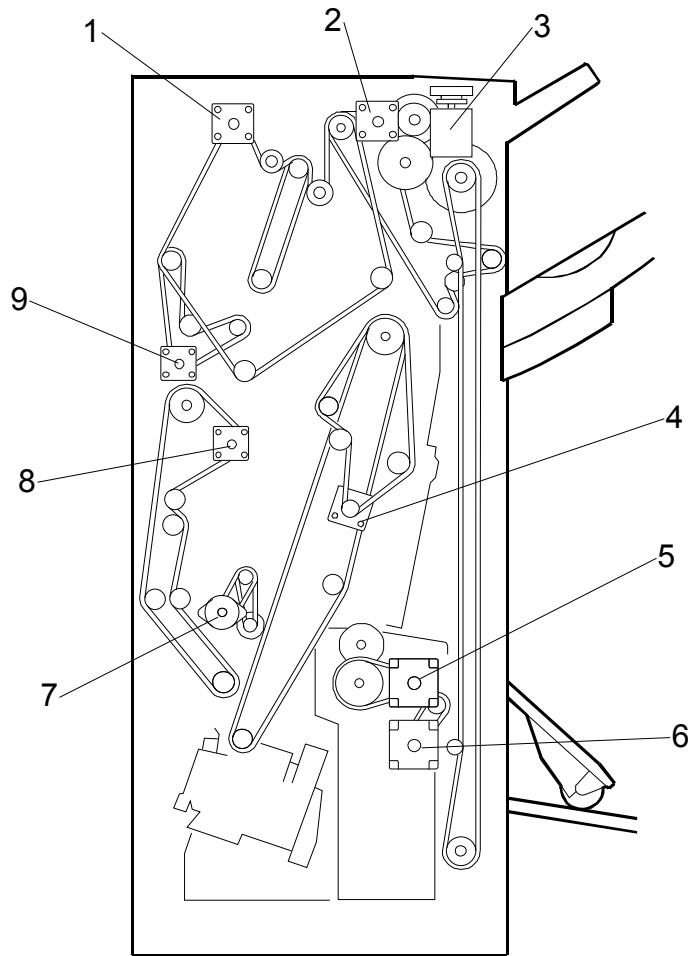

- | | |
|--|---|
| 1. Upper Transport Motor (M2) | 6. Folder Plate Motor* ¹ (M11) |
| 2. Upper/Proof Exit Motor (M4) | 7. Positioning Roller Motor (M14) |
| 3. Upper Tray Lift Motor (M21) | 8. Lower Transport Motor (M3) |
| 4. Feed-Out Belt Motor (M5) | 9. Entrance Motor (M1) |
| 5. Fold Roller Motor* ¹ (M12) | |

*¹ B700 Only

2.4 JUNCTION GATES

The positions of the proof tray and staple tray junction gates determine the direction of paper feed after paper enters the finisher.

Proof Mode

- [A]: Proof tray junction gate opens.
- [B]: Staple tray junction gate remains closed.

The proof tray junction gate directs paper to the proof tray above.

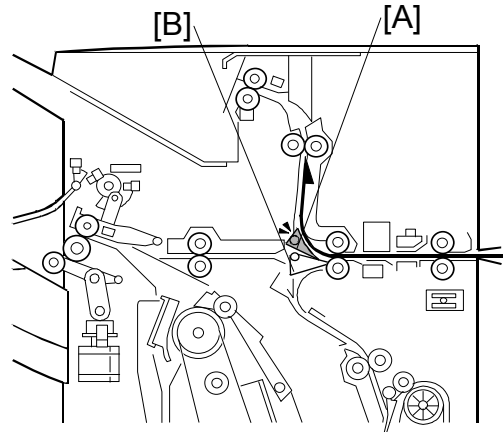

Shift Mode

- [A]: Proof tray junction gate remains closed.
- [B]: Staple tray junction gate remains closed.

With both junction gates closed, the paper goes to the upper tray.

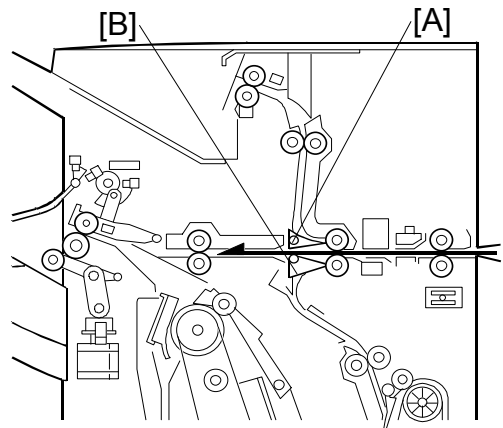

Staple Mode

- [A]: Proof tray junction gate remains closed.
 - [B]: Staple tray junction gate opens
- The staple tray junction gate directs the paper to the staple tray below for jogging and stapling.

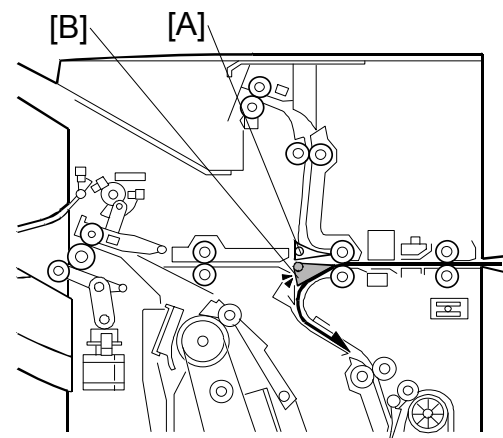

2000/3000
Sheet
Finisher
B700/B701

2.5 PRE-STACKING

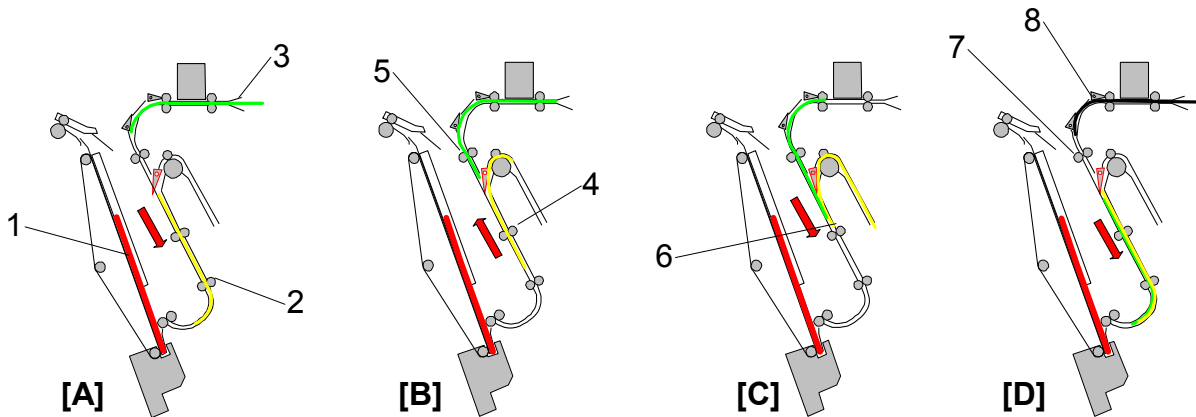

This example describes what happens to Set 2 during the feed and stapling cycle of sets that contain three pages.

- [A]: While the Set 1 is being stapled in the staple tray [1], the 1st sheet of Set 2 [2] feeds to the pre-stack tray, and the 2nd sheet of Set 2 [3] enters the finisher.
- [B]: The pre-stack junction gate opens and the 1st sheet of Set 2 [4] switches back to the top of the pre-stack tray as the 2nd sheet of Set 2 [5] starts to descend.
- [C]: As the 2nd sheet of Set 2 continues to descend, the 1st sheet of Set 2 is fed from the pre-stack tray. At this time the leading edges [6] of both sheets are even.
- [D]: The trailing edges of the 1st and 2nd sheets of Set 2 pass the junction gate [7] as the 3rd sheet of Set 2 [8] enters the finisher.

PRE-STACKING

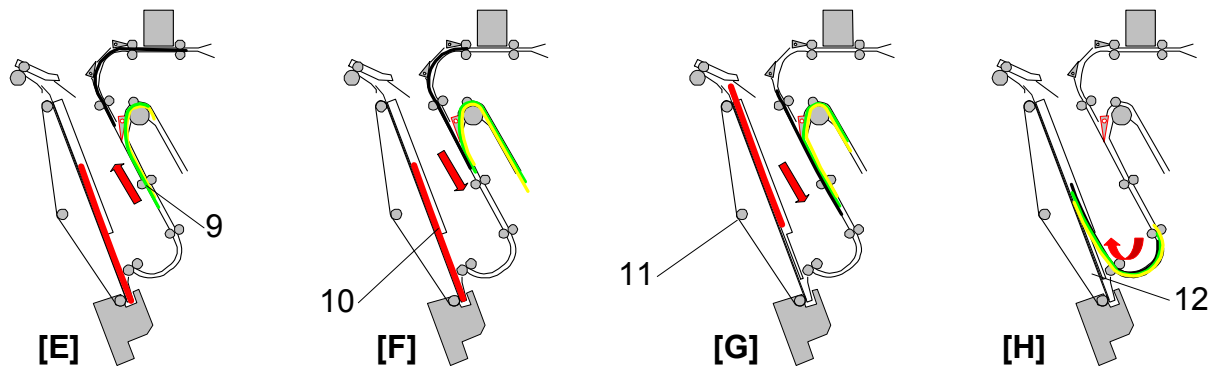

[E]: The 1st and 2nd sheets of Set 2 [9] switch back together into the top of the pre-stack and wait for the 3rd of Set 2 sheet to arrive.

[F]: The stapling of Set 1 in the staple tray [10] is completed.

[G]: Set 1 [11] exits the staple tray.

[H]: The three sheets of Set 2 [12] feed together into the stapler tray for stapling.

Pre-stacking is only done for A4, B5, and LT paper.

In one-staple mode, one sheet goes to the pre-stacking tray. Then two sheets go to the stapler tray at the same time.

In two-staple mode and booklet mode, three sheets go to the pre-stacking tray. Then four sheets go to the stapler tray at the same time.

2000/3000
Sheet
Finisher
B700/B701

2.6 UPPER TRAY

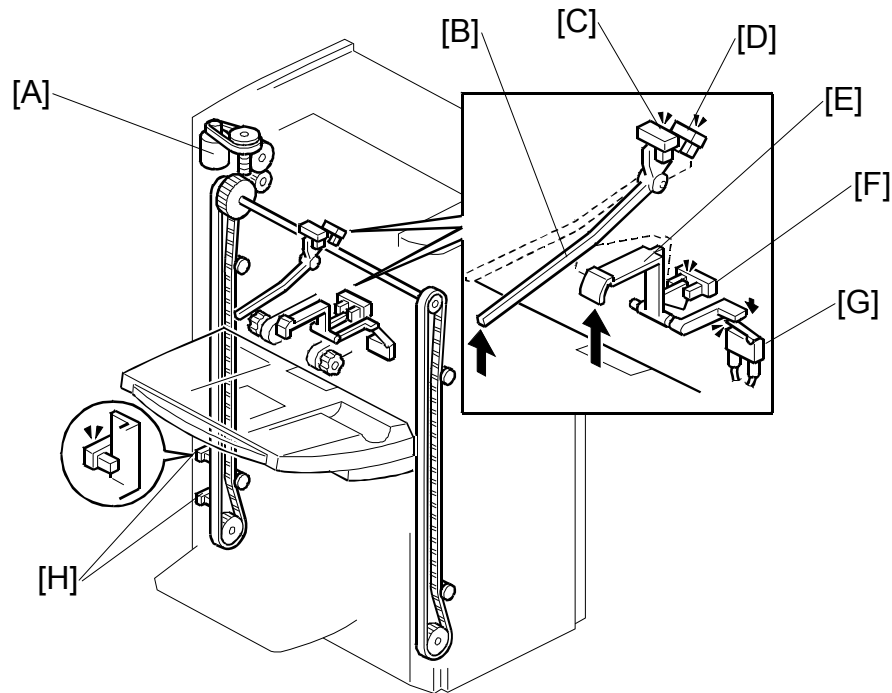

- [A]: Upper Tray Lift Motor
- [B]: Upper Feeler
- [C]: Upper Tray Paper Height Sensor 1 (Staple Mode)
- [D]: Upper Tray Paper Height Sensor 2 (Non-Staple Mode)
- [E]: Lower Feeler
- [F]: Upper Tray Limit Sensor
- [G]: Upper Tray Limit Switch
- [H]: Upper Tray Full Sensors

Important

- The B700 (shown above) has only one upper tray full sensor (the higher sensor at [H])
- The B701 has two upper tray full sensors (the upper and lower sensor at [H]). On the B701 the upper sensor detects tray full for heavier paper (A3, DLT, B4, LG, 12 x 18”), and the lower sensor detects tray full for lighter paper (A4, LT, etc.).
- The tray full capacity is 2,000 sheets (B700) for A4, LT and 3,000 sheets (B701) for A4, LT.

Five sensors and one switch control the operation of the upper tray lift motor [A].

Upper Tray Raising and Lowering

Operation Mode	Sensors, Switch				Action
	[C]	[D]	[F]	[G]	
Standby (Non-Staple Mode)	OFF	OFF			Stops the lift motor is at the standby position when the actuator of the upper feeler deactivates sensor [C] (when it is between sensors [C] and [D]). Note: Sensor [F] and switch [G] are used as backup if sensor [C] fails or if the upper tray is not attached.
Straight Through			ON		Non-staple mode operation: During operation, tray lift is controlled only by sensor [F]. When the actuator leaves sensor [F], the tray lowers until the actuator reactivates sensor [F].
Shift			ON		
Standby (Staple Mode)	ON				Standby: The upper tray stops and waits for the paper output when the actuator activates sensor [C]. [D] is not used for staple mode Staple Mode Operation: <ul style="list-style-type: none"> • The upper tray lowers the prescribed distance immediately after the stack exits. • The upper tray rises until the actuator activates sensor [C] and stops the tray lift motor (and the tray) to wait for the next set. • Sensor [F] and switch [G] are used as backup if sensor [C] fails.

2000/3000
Sheet
Finisher
B700/B701

Tray Full

B700	When the actuator on the tray activates the upper tray full sensor [H] the tray lift motor [A] switches off. Operation resumes after some copies are removed from the tray. Upper Tray Capacity: 2,000 sheets (A4, LT)
B701	The operation of the upper tray full sensor is the same as the B700. Capacity: 1,500 sheets for A3, B4 or other large paper. An additional upper tray full sensor (below sensor [H]) allows more sheets to stack on the upper tray. Capacity: 3,000 sheets (A4, LT)

2.7 LOWER TRAY (B700 ONLY)

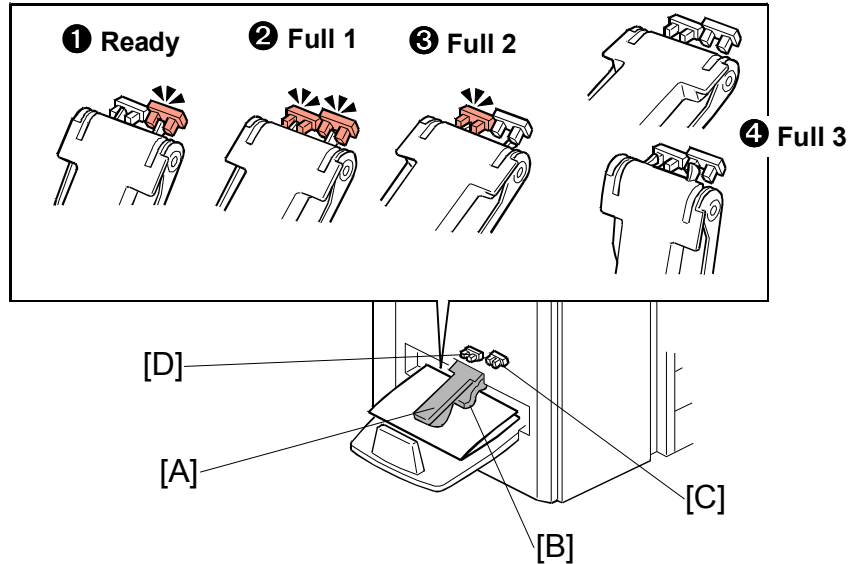

The lower tray sensor actuator arm [A] rests on the top of the stack of stapled booklets as they are output to the lower tray. A flap depressor [B] keeps the open ends of the booklets down.

The front lower tray full sensor (S34) [C] and rear lower tray full sensor (S33) [D] detect when the lower tray is full of booklets.

Important

- The front lower tray full sensor is mounted higher than the rear lower tray full sensor.
- The lower tray is stationary. When it becomes full, the stapling and folding job stops until booklets are removed from the tray.
- If the lower tray is not installed (this is detected if the front and rear sensors remain OFF), the machine will not operate in the booklet staple and fold mode. When booklet mode is selected, the tray full message appears on the operation panel.

The combinations of the two actuators and two sensors as the actuator arm rises determines the number of booklets that the lower tray can hold before the job stops.

The tray full detection depends on the size of the paper and the number of sheets in one stapled and folded booklet.

In the table below, the conditions (❶ Ready ❷ Full 1, ❸ Full 2 ❹ Full 3: See the illustration on the previous page) refer to the states of the sensors described on the previous page.

Condition	Front Sensor	Rear Sensor
Ready	ON	OFF
Full 1	ON	ON
Full 2	OFF	ON
Full 3 (or lower tray not installed)	OFF	OFF

In the tables below:

- "Sht" denotes "sheets in a stack".
- "Cnt" denotes "Count" (see below for an explanation).

After a booklet is feed out, the fold roller motor stops the exit roller. The machine then monitors the tray full sensors every 100 ms. The machine checks for a certain condition, based on the size of the paper and the number of sheets in the booklet.

An example is shown below. Tell the operators that the number of sheets that the lower tray can hold will vary greatly.

Lower Tray Full Condition Table

A3 (DLT)

	1 Sht	2 Sht	3 Sht	4 Sht	5 Sht	6 Sht	7 Sht	8 Sht	9 Sht	...
Full 1	3 Cnt	—	—	—	—	—	—	—	—	...
Full 2	—	5 Cnt	15 Cnt	—	—	—	—	—	—	...
Full 3	—	—	—	7 Cnt	13 Cnt	4 Cnt	2 Cnt	2 Cnt	2 Cnt	...

A4 (LT)

	1 Sht	2 Sht	3 Sht	4 Sht	5 Sht	6 Sht	7 Sht	8 Sht	9 Sht	...
Full 1	16 Cnt	—	—	—	—	—	—	—	—	...
Full 2	—	10 Cnt	10 Cnt	15 Cnt	20 Cnt	15 Cnt	10 Cnt	8 Cnt	8 Cnt	...
Full 3	—	—	—	—	—	—	—	—	—	...

Examples

After the copier makes a booklet with 1 sheet of A3/DLT paper, the machine checks every 100 ms for the 'Full 1' condition. If the Full 1 condition occurs 3 times (shaded block in the table above), the machine detects that the tray is full.

After the copier makes a booklet with 5 sheets of A4/LT paper, the machine checks every 100 ms for the 'Full 2' condition. If the Full 2 condition occurs 20 times (shaded block in the table above), the machine detects that the tray is full.

2000/3000
Sheet
Finisher
B700/B701

2.8 CORNER STAPLING

2.8.1 STACKING AND JOGGING

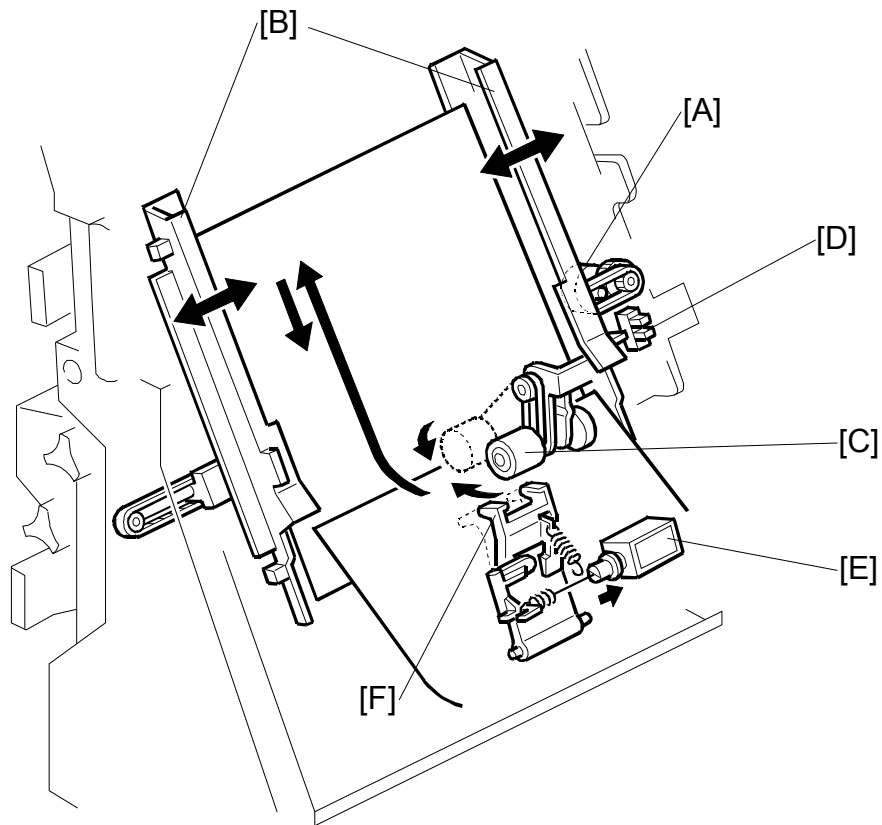

- [A]: Jogger Fence Motor (M15)
- [B]: Jogger Fences
- [C]: Positioning Roller
- [D]: Jogger Fence HP Sensor (S15)
- [E]: Stapling Edge Pressure Plate Solenoid (SOL4)
- [F]: Pressure Plate

At the beginning of the job, the jogger fence motor (M15) [A] switches on and moves the jogger fences [B] to the standby position (7.5 mm from the sides of the selected paper size).

When each sheet passes the pre-stack tray exit sensor (S2) and enters the stapling tray:

- The jogger fence motor switches on and moves the jogger fences to within 5.5 mm of the sides of the selected paper size.
- The positioning roller solenoid (SOL3) switches on for the time prescribed for the paper size. This pushes the positioning roller [C] onto the sheet and pushes it down onto bottom fence. This aligns the edge of the stack.

Next, the jogger fence motor:

- Switches on again and moves the jogger fences to within 2.6 mm of the sides of the stack to align the sides of the stack.
- Reverses and moves the fences to the standby position (7.5 mm away for the sides) and waits for the next sheet.
- The jogger fence HP sensor [D] switches off the jogger motor at the end of the job.

After the last sheet feeds:

- The stapling edge pressure plate solenoid [E] (SOL4) switches on and pushes the pressure plate [F] onto the stack to press down the edge for stapling.
- The corner stapler staples the stack.

CORNER STAPLING

2.8.2 STAPLER MOVEMENT

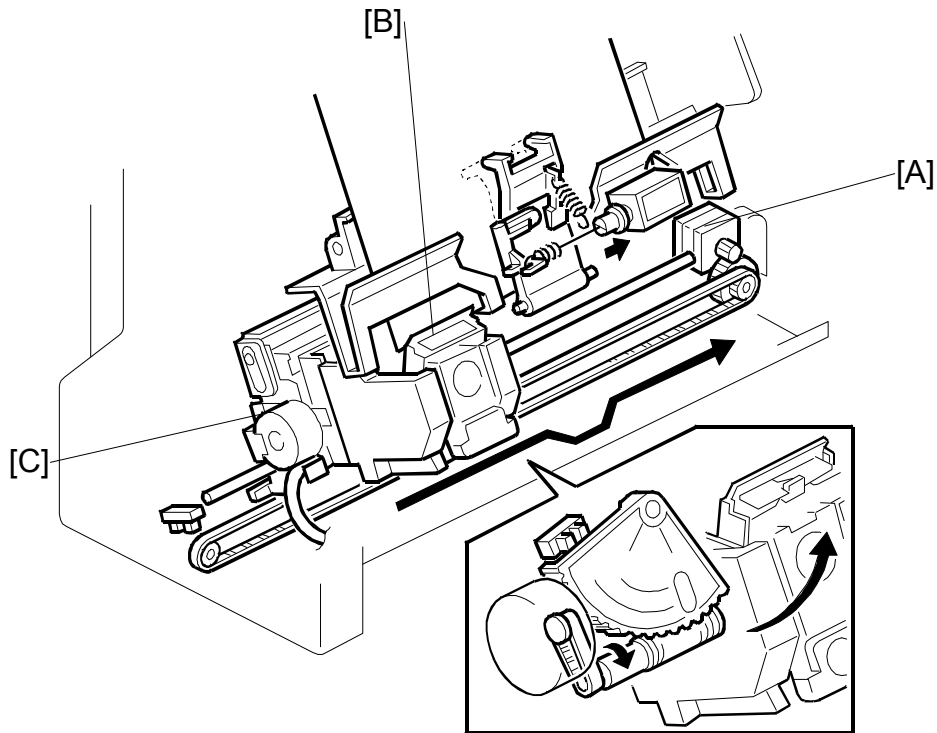

- [A]: Stapler Movement Motor
- [B]: Stapler
- [C]: Stapler Rotation Motor

The stapler performs horizontal and rotational movement in each of the four staple modes:

- Front 1 staple
- Rear 1 staple
- Rear diagonal staple
- Rear/Front 2 staples.

The stapler movement motor [A] drives a timing belt that moves stapler [B] left and right on its stainless steel rail.

The stapler rotation motor [C] rotates the stapler into position for diagonal stapling at the rear.

- The stapler movement motor switches on and moves the stapler the standby stapling position. (This is the stapling position for the paper size selected for the job.)
- The stapler movement motor switches off and the stapler waits for the signal to fire (or swivel and for diagonal stapling).

If the stack is to be stapled at two positions:

- The stapler movement motor moves the stapler to the front position and staples the front.
- The stapler movement motor moves the stapler to the rear and the stapler staples the rear.

If the stack will be stapled at the rear with a diagonal staple, the staple moves to the rear. When it is time for stapling, the rotation motor rotates the stapler to the correct angle and holds the stapler in that position while the stapler fires.

The stapling positions can be fine adjusted with **SP6109**.

2.8.3 CORNER STAPLING

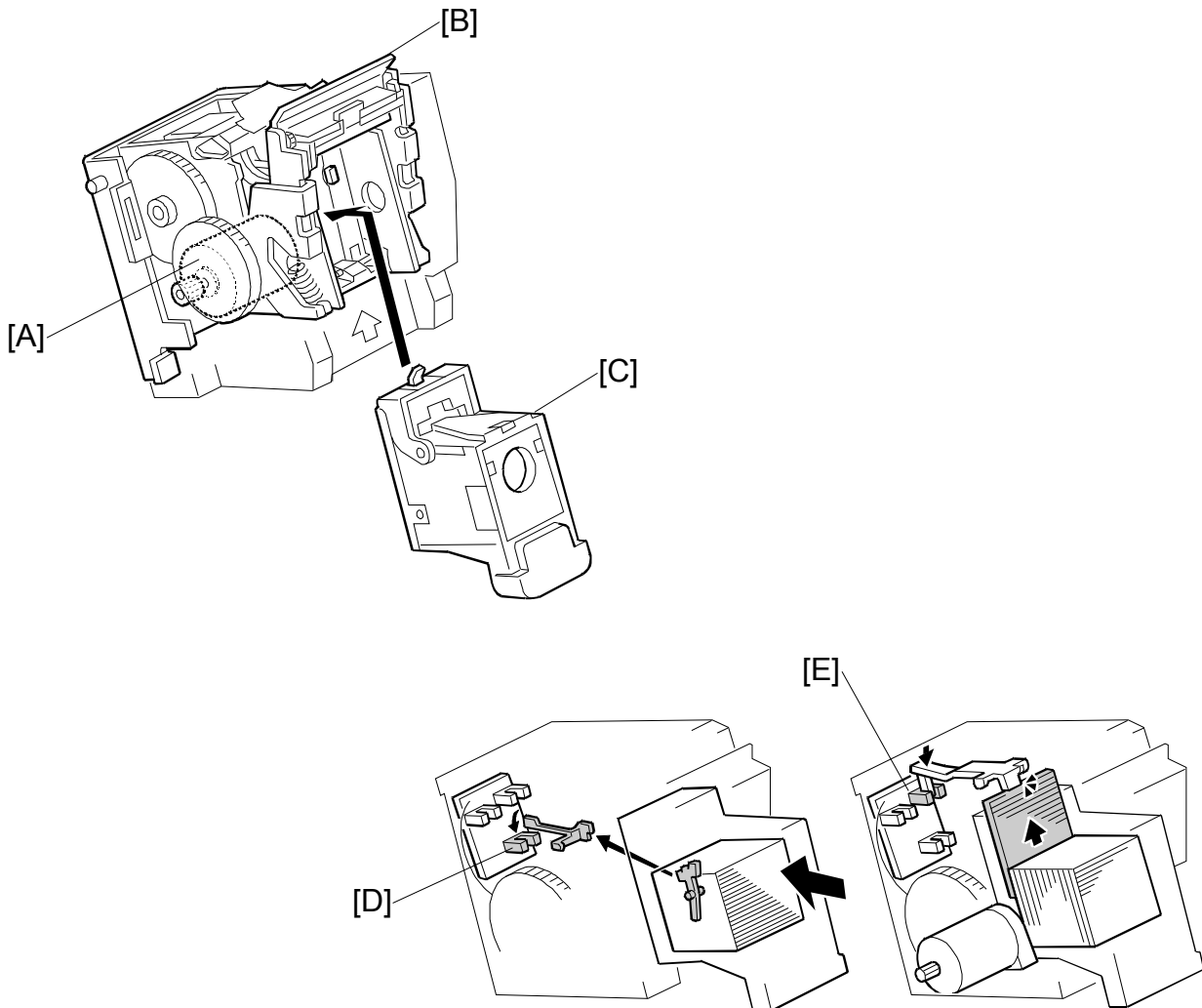

Staple firing is driven by the stapler motor [A] inside the stapler unit. The stapler hammer [B] fires the stapler [C].

The cartridge set sensor [D] detects the cartridge at the correct position.

The staple end sensor [E] detects the staple end condition.

2.9 BOOKLET STAPLING (B700 ONLY)

2.9.1 BOOKLET PRESSURE MECHANISM

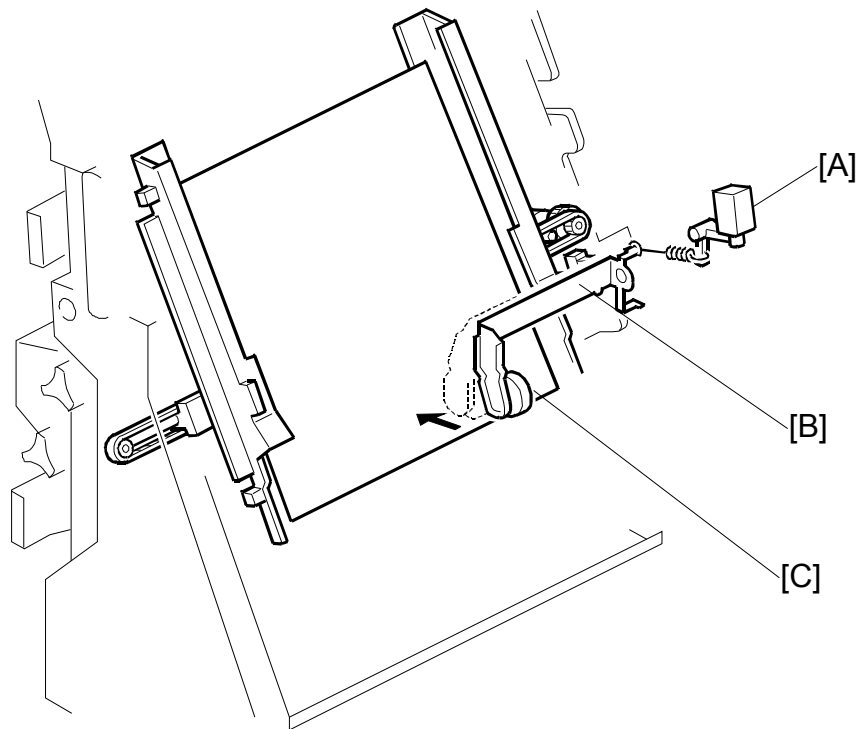

- [A]: Booklet Pressure Roller Solenoid (SOL5)
- [B]: Booklet Pressure Roller Arm
- [C]: Booklet Pressure Roller

As soon as the edges are aligned by the positioning roller and the jogger fences, the stack feed out belt moves.

In booklet mode, immediately after the edges are aligned by the positioning roller and jogger fences, the booklet pressure solenoid switches on and the booklet pressure roller presses down on the stack until booklet stapling is finished. This prevents the stack from shifting during stapling.

2000/3000
Sheet
Finisher
B700/B701

2.9.2 BOOKLET STAPLING AND FOLDING

Overview

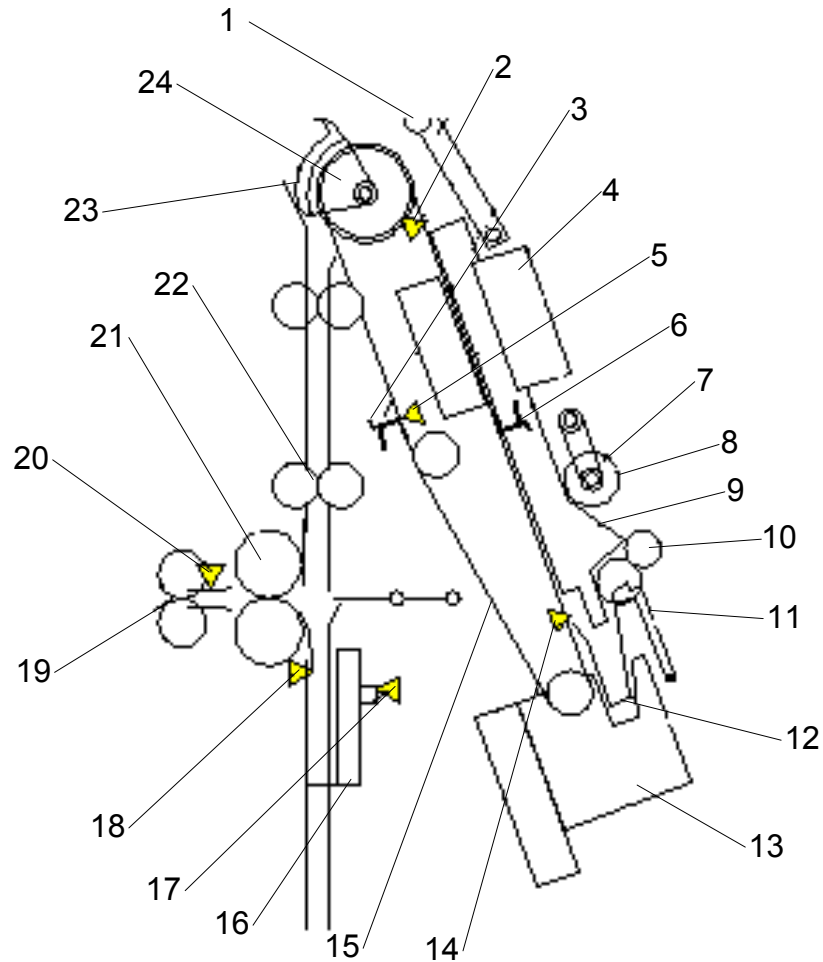

- | | |
|--|---------------------------------------|
| 1. Leading Edge Pressure Roller | 13. Corner Stapler (M20) |
| 2. Stack Present Sensor (S32) | 14. Stapling Tray Paper Sensor (S14) |
| 3. Feed Out Belt Pawl 1 | 15. Feed Out Belt |
| 4. Booklet Staplers x2 (M22, M23) | 16. Fold Unit Bottom Fence |
| 5. Stack Feed Out Belt HP Sensor (S16) | 17. Fold Bottom Fence HP Sensor (S28) |
| 6. Feed Out Belt Pawl 2 | 18. Fold Unit Entrance Sensor (S26) |
| 7. Positioning Roller | 19. Fold Unit Exit Rollers x2 |
| 8. Booklet Pressure Roller (Rear) | 20. Fold Unit Exit Sensor (S31) |
| 9. Jogger Fences x2 | 21. Fold Rollers x2 |
| 10. Pre-Stack Exit Roller | 22. Clamp Rollers x2 |
| 11. Pressure Plate | 23. Stack Junction Gate |
| 12. Stapling Tray Bottom Fence | 24. Stack Transport Roller |

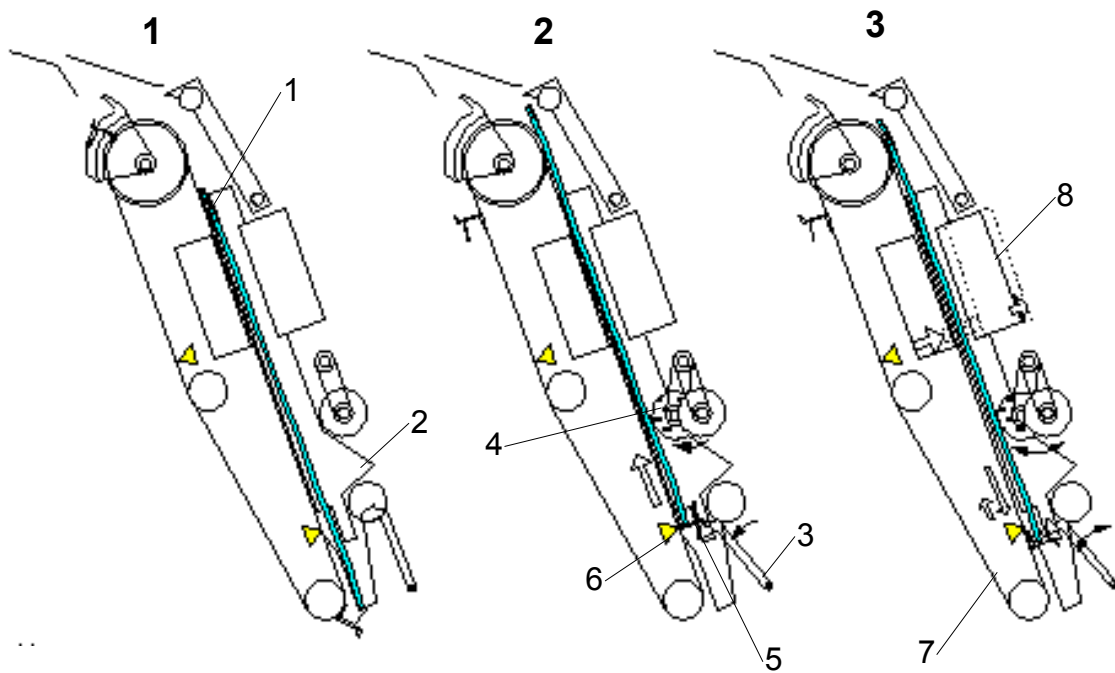

1

The last sheet of the stack [1] enters the stapling tray. The jogger fences [2] jog the last sheet into position (based on the width of the selected paper size) and then retract and stop 1 mm away from the sides of the stack.

2

The pressure plate [3] and booklet pressure roller [4] press down on the sheet. The stack feed out belt switches on and the pawl [5] on the feed out belt catches the bottom of the stack and raises it. The stapling tray sensor [6] detects the trailing edge of the paper stack.

3

The feed out belt [7] raises the stack to the prescribed stapling position and stops. The jogger fences move to the sides of the stack and the booklet staplers [8] staple the stack.

2000/3000
Sheet
Finisher
B700/B701

BOOKLET STAPLING (B700 ONLY)

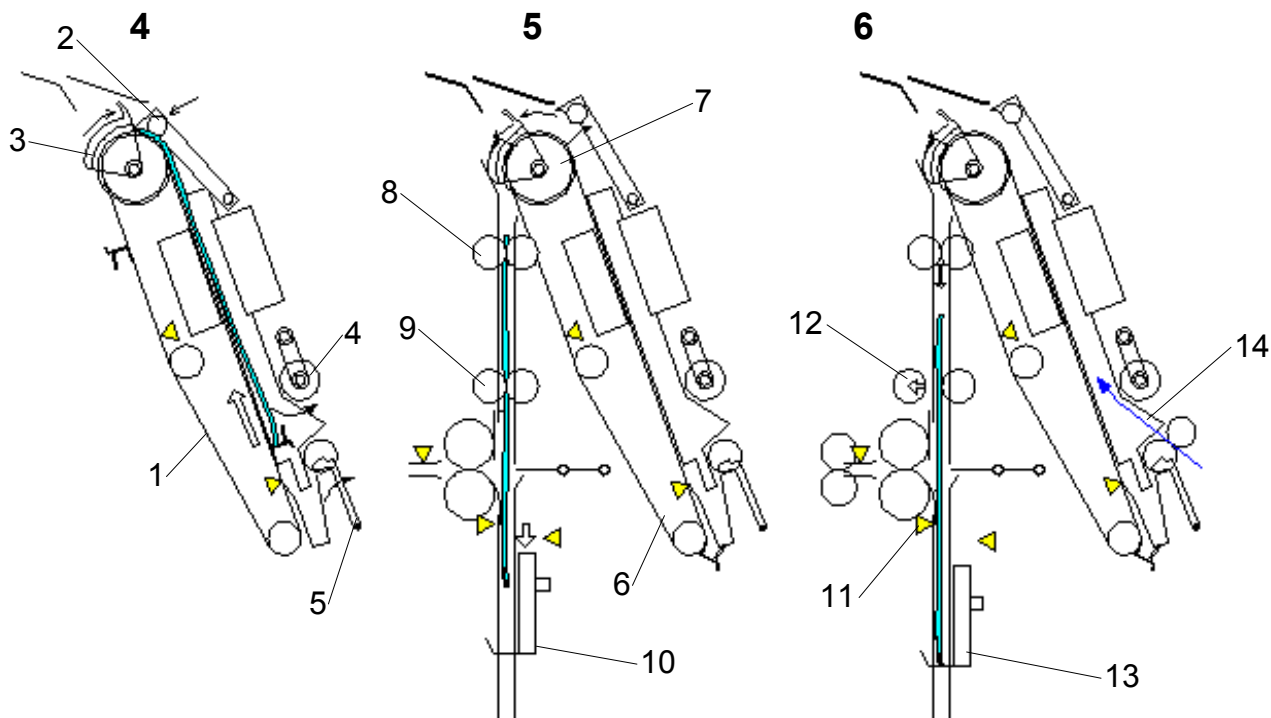

4

The jogger fences remain 1 mm away from the sides of the stack. The feed out belt [1] raises the stack until the top of the stack is 10 mm past the leading edge pressure roller [2] and stops. The leading edge pressure roller descends and applies pressure to the top of the stack. The stack junction gate [3] (normally open) closes. The pressure roller [4] and pressure plate [5] retract.

5

The feed out belt [6], transport rollers [7], [8], and clamp rollers [9] rotate and feed the stack past the closed stack junction, over the top and down toward the bottom fence [10]. At the same time, the fold unit bottom fence descends from its home position and stops 10 mm below the fold position.

6

The rollers feed the leading edge of the stack to within 3 mm of the stack stopper of the bottom fence [13]. The fold unit entrance sensor [11] detects the stack and opens the clamp rollers [12]. The stack drops 3 mm onto the fold unit bottom fence [13]. At this time, the first sheet [14] of the next stack feeds to the stapling tray.

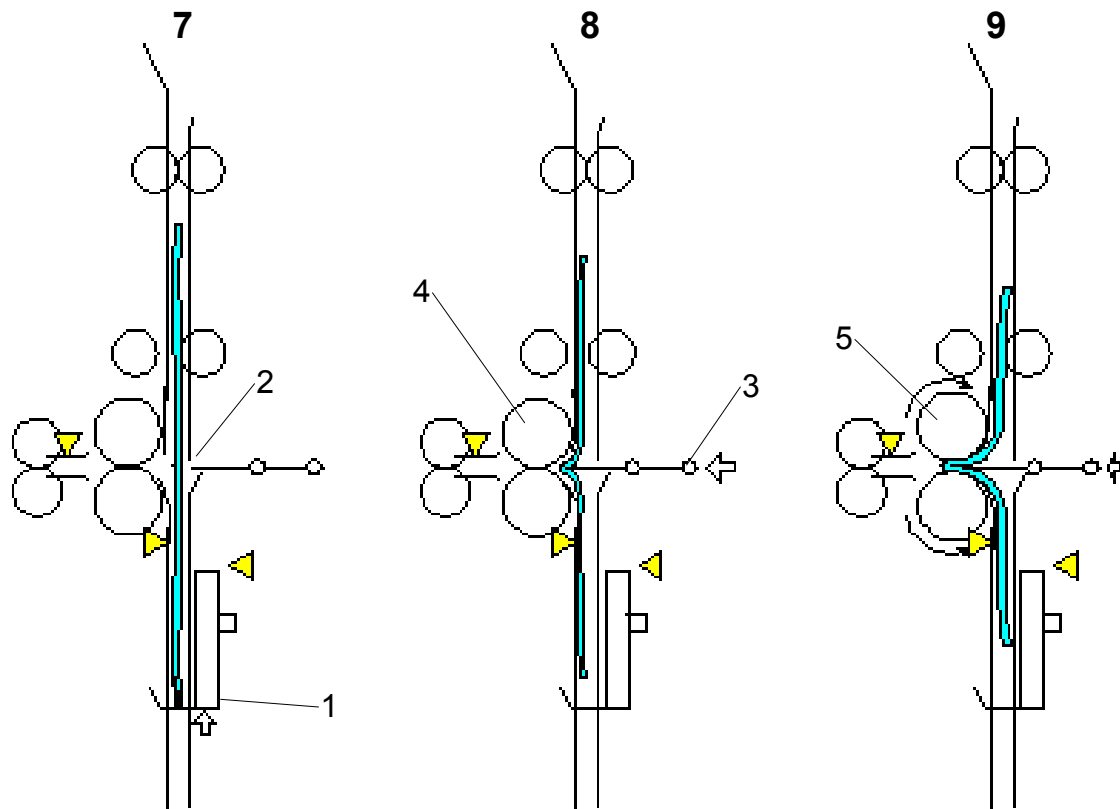

2000/3000
Sheet
Finisher
B700/B701

7

The bottom fence [1] raises the stack to the prescribed fold position [2].

8

The fold plate [3] moves to the left and advances 1/3 its maximum horizontal stroke and exerts 20 kg (44 lb.) of pressure at the fold rollers [4].

9

With the fold plate pushing the stack into nip of the fold rollers [5], the fold rollers begin to rotate and fold the stack as it feeds out.

BOOKLET STAPLING (B700 ONLY)

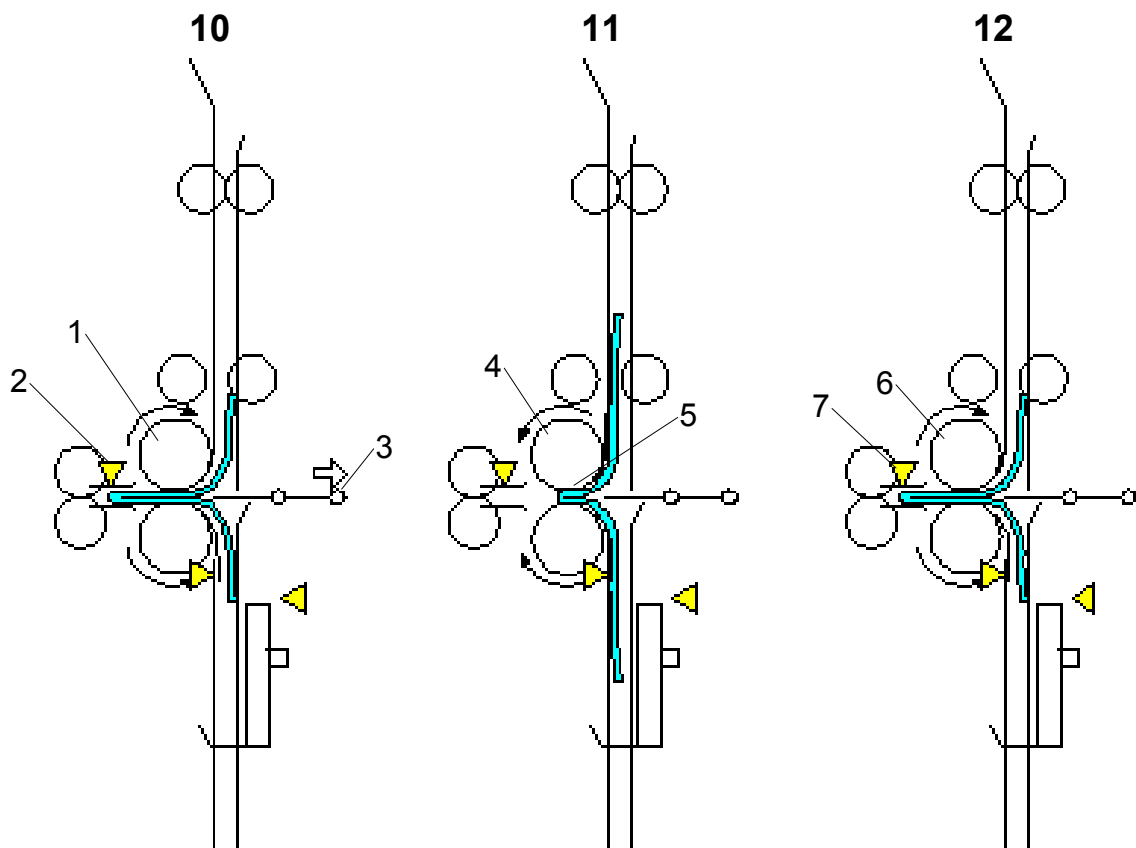

10

When the fold rollers [1] feed the stack 10 mm past the nip, the fold plate retracts until it no longer touches the stack. The fold unit exit sensor [2] detects the folded edge of the stack and stops the fold rollers.

11

The rotation of the fold rollers [4] reverses and feeds the folded edge back until only 3 mm of the fold [5] remains at the nip.

12

The fold rollers [6] rotate forward once again feed out. The fold unit exit sensor [7] once again detects the edge of the fold.

NOTE: You can do **SP6114** to increase the sharpness of the fold. The number of forward and reverse feeds can be set in the range of 2 to 30. The machine repeats Steps 11 and 12. For more, please refer to Section "5 Service Tables*."

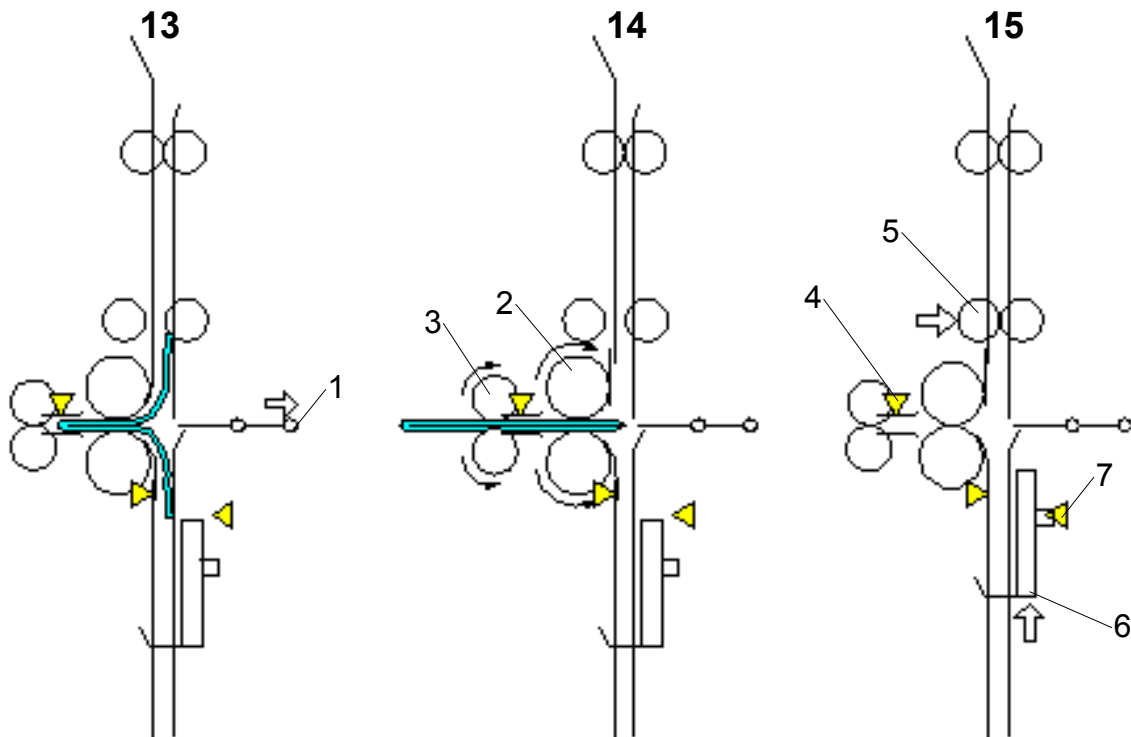

13

With the feed of the stack halted, the fold plate [1] retracts. The fold plate HP sensor (not shown) detects the fold plate and stops it at its home position.

14

The fold rollers [2] and fold unit exit rollers [3] begin to rotate together and feed out the folded booklet to the lower tray.

15

Once the trailing edge of the stack passes the fold unit exit sensor [4], the clamp rollers [5] close to be ready to feed the next stack. The fold unit bottom fence [6] descends. The bottom fence HP sensor [7] stops the bottom fence when it detects the actuator on the bottom fence.

2000/3000
Sheet
Finisher
B700/B701

Booklet Stapling and Folding Mechanisms

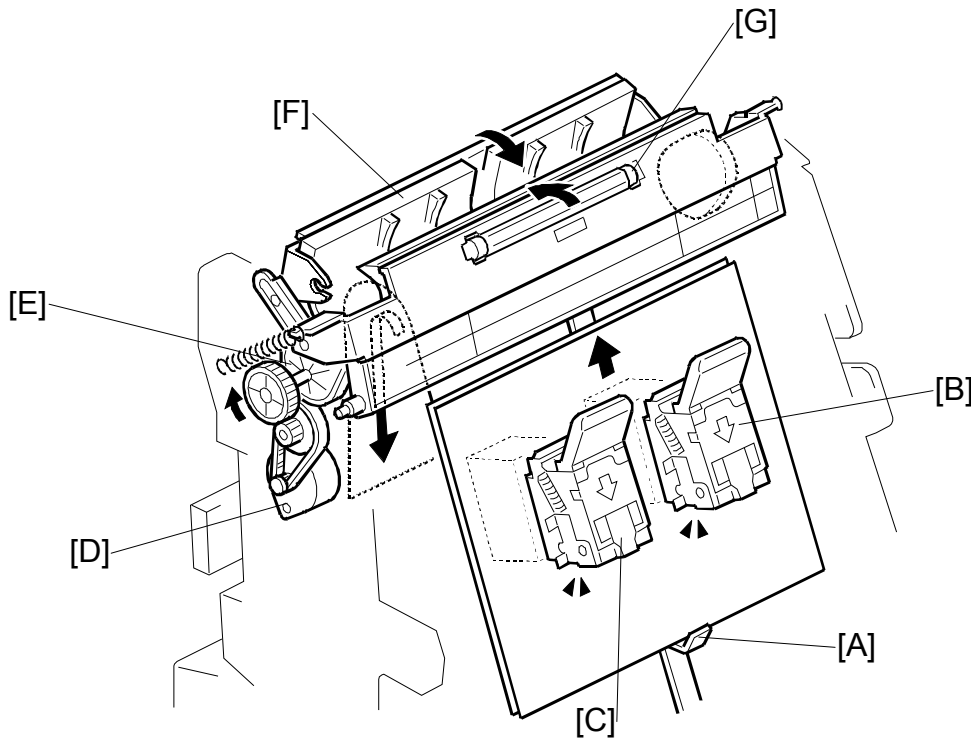

Booklet Stapler

[A]: Feed Out Belt Pawl. Raises the stack to stapling position.

[B]: Booklet Stapler EH185R – Rear

[C]: Booklet Stapler EH185R – Front

Stack Junction Gate

[D]: Stack Junction Gate Motor. Drives a timing belt and stack junction gate cam.

[E]: Stack Junction Gate Cam. Opens and closes the stack junction gate.

[F]: Stack Junction Gate. The stack junction gate motor and stack junction gate cam close the stack junction gate. The feed out belt pawl raises the stapled stack and sends it over the top and down to the fold unit.

[G]: Leading Edge Pressure Roller. Presses down on the leading edge of the stack after booklet stapling.

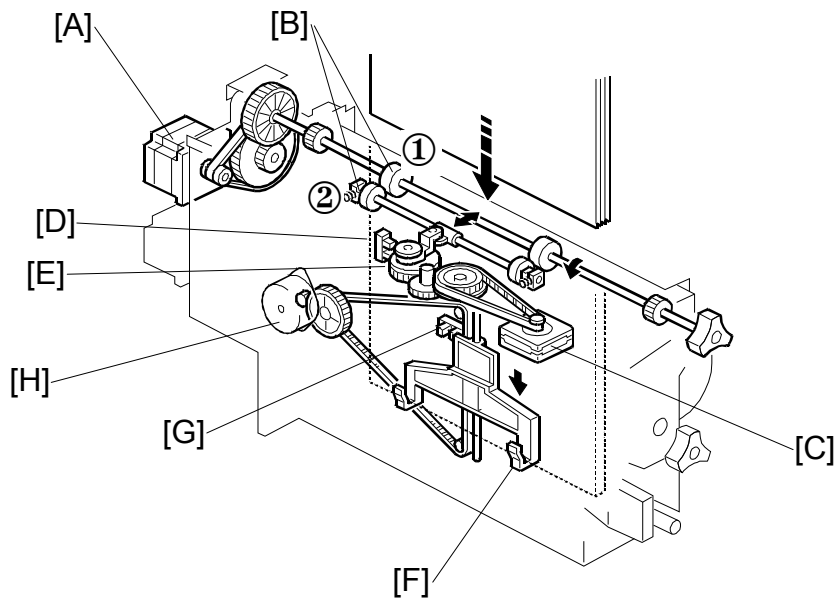

Clamp Roller

[A]: Fold Roller Motor. Drives the stationary clamp drive roller ① as well as the fold rollers (see next page).

[B]: Clamp Rollers.

① Clamp Roller – Drive. Rotated by the fold roller motor, this stationary roller feeds the stack down with the retracting roller closed.

② Clamp Roller – Retracting. Opened and closed by the retraction motor [C].

[C]: Clamp Roller Retraction Motor. Operates the clamp roller cam that retracts the retracting clamp roller. The clamp rollers feed the stack to within 3 mm of the bottom fence when closed and then open to drop the stack onto the bottom fence.

[D]: Clamp Roller HP Sensor. Controls the rotation of the clamp roller retraction motor and cam that open and close the retracting clamp roller.

[E]: Clamp Roller Cam. Forces open the spring loaded retracting clamp roller.

Bottom Fence

[F]: Bottom Fence. Raises the booklet stapled stack to the fold position.

[G]: Bottom Fence HP Sensor. Detects the actuator on the bottom fence and stops it at the home position after folding.

[H]: Bottom Fence Lift Motor. Raises the bottom fence and stapled stack to the fold position prescribed for the paper size.

BOOKLET STAPLING (B700 ONLY)

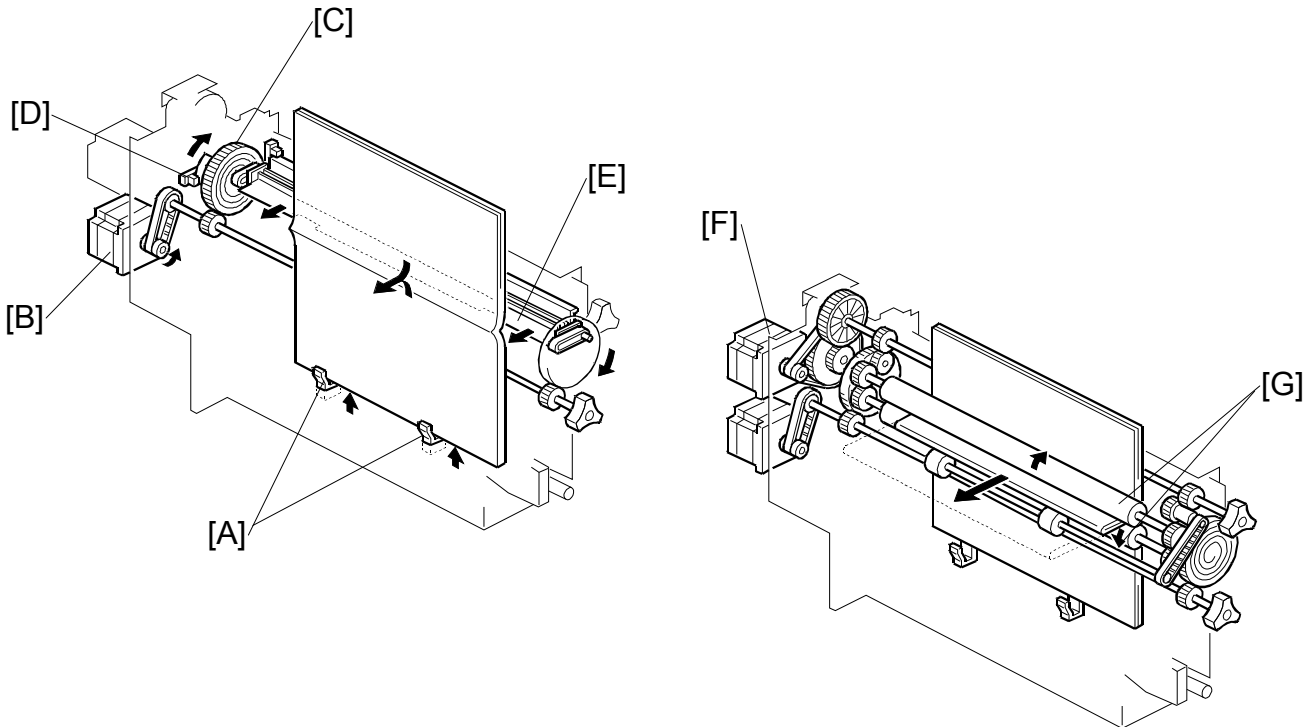

Fold Plate

- [A]: Bottom Fence Stack Stoppers. Catches the stack after it is released by the clamp rollers.
- [B]: Fold Plate Motor. Drives the timing belt and gears that move the fold plate.
- [C]: Fold Plate Cam. Controls the movement of the fold plate to the left (into the nip of the fold rollers) and right (toward the fold plate home position).
- [D]: Fold Plate HP Sensor. Controls operation of the fold plate motor.
- [E]: Fold Plate. Moves left and pushes the stack into the nip of the fold rollers and then moves right to retract.

Fold Rollers

- [F]: Fold Roller Motor. Drives forward to feed out the stack at the fold and then reverses to feed the fold in to sharpen the crease, and then drives forward again to feed out the folded stack. This reverse/forward cycle is done once.

NOTE: This cycle can be repeated by changing the setting of **SP6114**.

- [G]: Fold Rollers. Driven by the fold roller motor, this roller pair feeds out the stack at its fold, reverses to feed in the stack to, and then feeds forward again (assisted by the fold unit exit rollers – not shown) to feed out the stack to the lower tray.

2.10 UPPER TRAY OUTPUT

2.10.1 FEED OUT

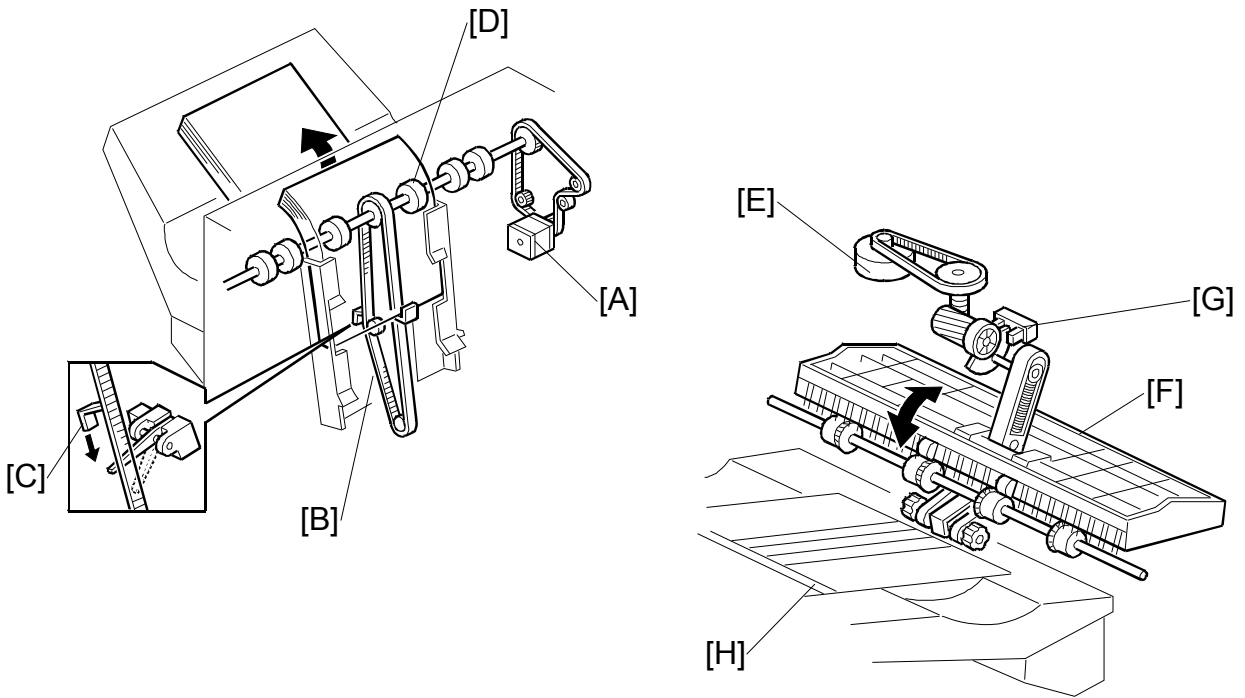

- [A]: Feed Out Belt Motor
- [B]: Stack Feed-Out Belt
- [C]: Pawl
- [D]: Exit Rollers
- [E]: Exit Guide Plate Motor
- [F]: Exit Guide Plate
- [G]: Exit Guide Plate HP Sensor
- [H]: Upper Tray

2000/3000
Sheet
Finisher
B700/B701

UPPER TRAY OUTPUT

After the stack is stapled, the feed out belt motor [A] switches on and drives the feed out belt [B].

The a pawl [C] attached to the feed out belt catches on the stack and lifts the stack toward the feed out slot.

The exit guide plate [F] remains open as the stack emerges at a prescribed distance away from the exit roller.

Next, the exit guide plate closes and the exit roller feeds the stack out.

The opening and closing of the exit guide plate is controlled by the rising and falling of a link driven by a rotating cam attached to the shaft of the exit guide plate motor [E].

The feed out belt motor stops 300 ms to prevent the stapled stack from rising too high.

Next, the feed out belt motor switches on again, then the pawl actuates its home position sensor and switches off the motor.

There are two output pawls on the feed out belt to improve the productivity of the feed out operation.

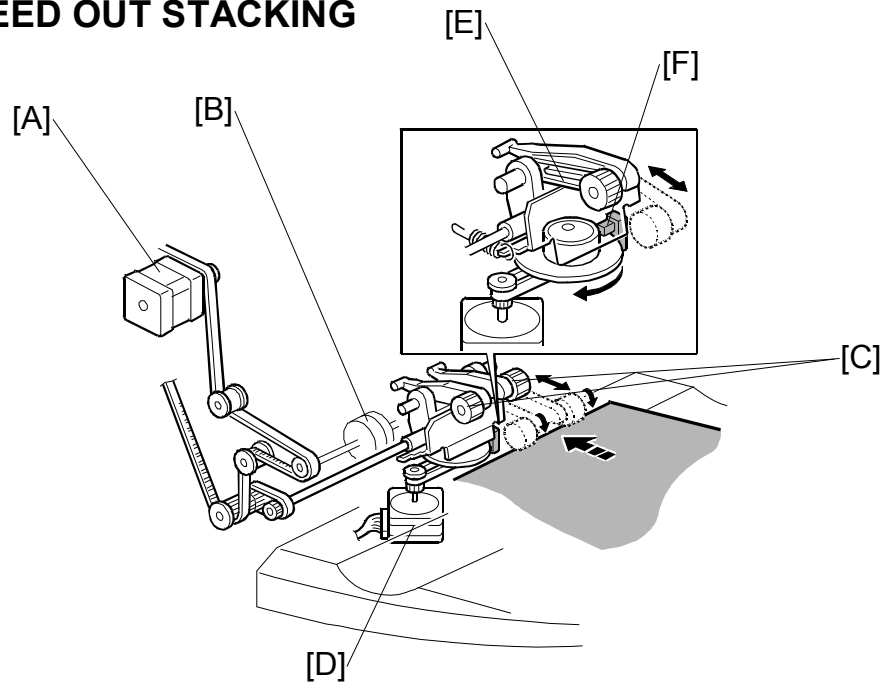
2.10.2 FEED OUT STACKING

Upper/proof exit motor [A] drives feed roller [B] and stacking sponge roller [C].

Stacking sponge roller motor [D] moves the sponge roller forward and back with link [E].

The position of the stacking sponge roller [C] is controlled by the stacking sponge roller motor which is switched on and off by the stacking roller HP sensor [F].

2.11 PUNCH UNIT B702 (FOR B700/B701)

2.11.1 OVERVIEW OF OPERATION

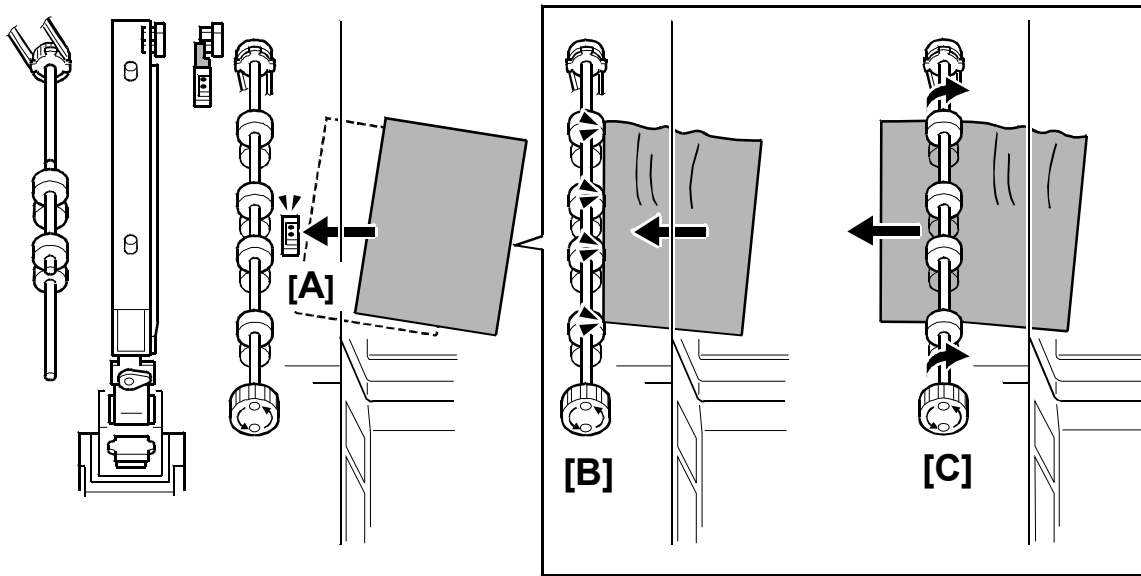

Skew Correction Before Punching

This punch unit corrects for paper skew and then positions the punch unit to punch holes at the correct position. Each sheet is punched one at a time.

Paper feeds out of the copier. The finisher entrance sensor [A] detects the leading edge of the sheet.

The finisher entrance roller [B] stops rotating briefly while the copier exit rollers continue to rotate. This buckles the paper against the finisher entrance roller to correct skew. The finisher entrance roller [C] starts to rotate again and feeds the sheet into the finisher.

These SP codes adjust the skew operation in the punch unit:

- **SP6103.** This SP corrects the punch hole alignment. To do this, it corrects the skew of each sheet by adjusting the amount of time the finisher entrance roller remains off while the exit roller of the machine remains on. For more, see Section "5. Service Tables".
- **SP6104.** This SP determines whether the finisher entrance roller stops to correct skew when paper enters the finisher. You can use this SP to disable the skew correction. For more, see Section "5. Service Tables".

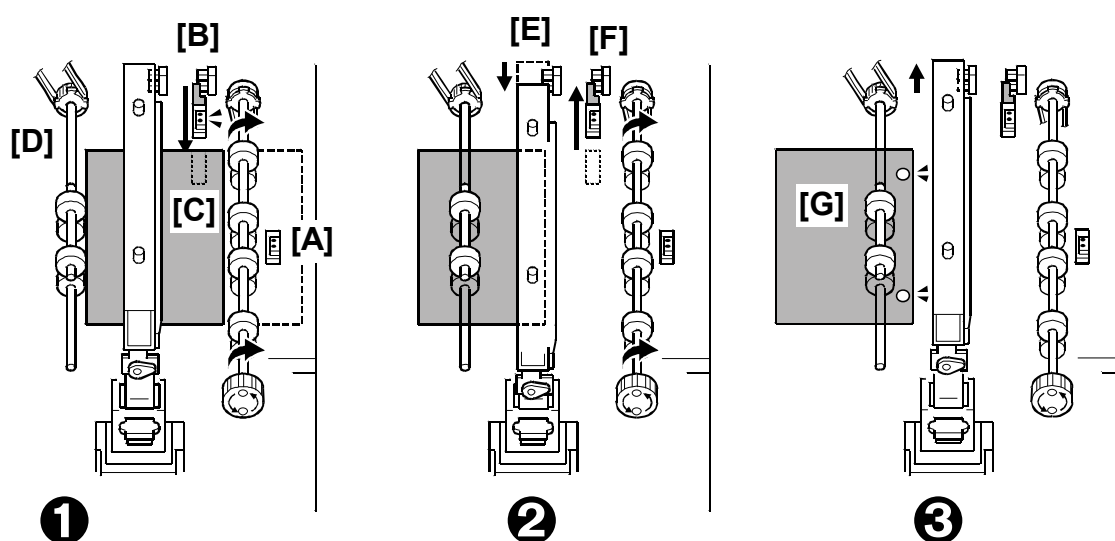

Punch Unit Position Correction

These operations (skew correction before punching, and punch unit position correction) increase the accuracy of the punch alignment.

- 1** The trailing edge of the sheet passes the finisher entrance sensor [A].

The paper position slide unit [B] moves the paper position sensor [C] forward to the edge of the paper.

The paper position sensor detects the position of the paper edge and sends this information to the punch unit board. The machine uses the detected position of the paper edge to calculate the correct position for punching.

The upper transport motor switches on and rotates the feed rollers [D] the prescribed distance to position the paper under the punch unit.
- 2** Using the result of the position calculation, the punch unit control board moves the punch unit [E] to the adjusted punch position.

The paper position slide unit and its paper sensor, move back to the paper position slide home position sensor [F], and the punch unit fires the punches to make the holes.
- 3** The feed rollers [G] feed the punched paper out of the punch unit and into the paper path.

PUNCH UNIT B702 (FOR B700/B701)

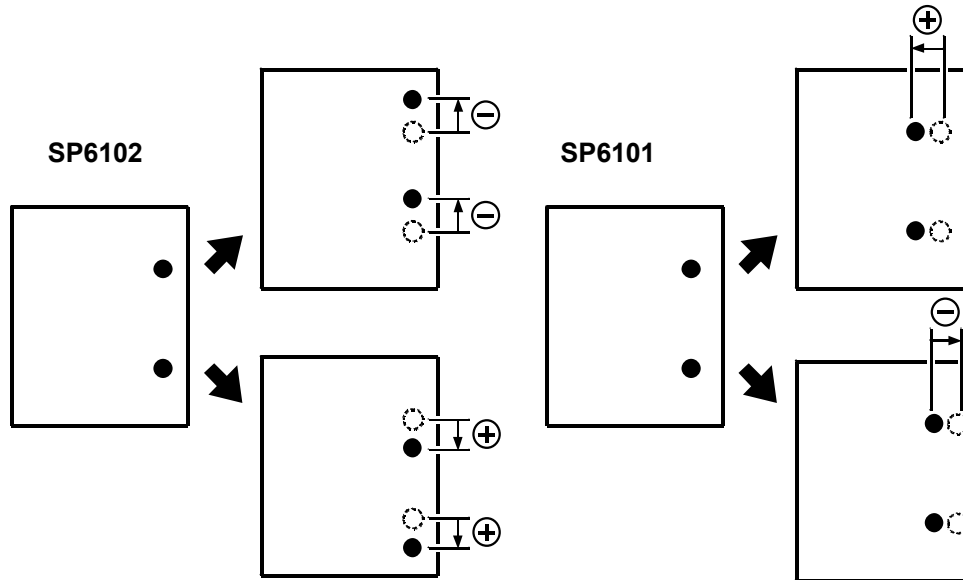

These SP codes adjust the punch hole alignment:

- **SP6101** Adjusts the punch positions in the direction of paper feed.
- **SP6102** Adjusts the punch position perpendicular to the direction of feed.

For more, see Section "5. Service Tables".

2.11.2 PUNCH MECHANISMS

Paper Position Detection

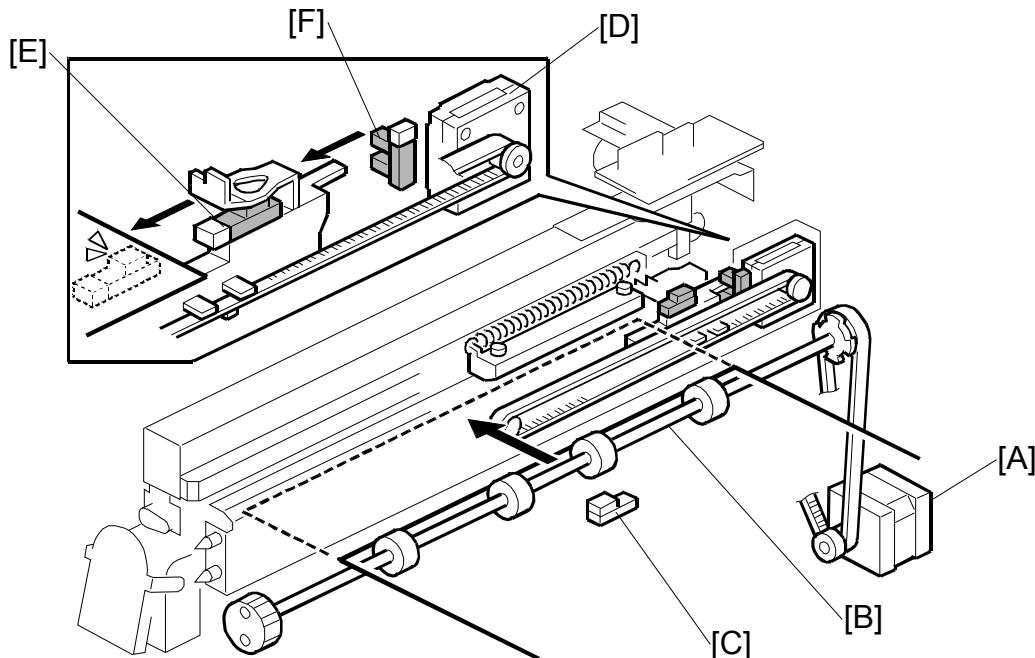

- [A]: Finisher Entrance Motor (M1)
- [B]: Finisher Entrance Roller
- [C]: Finisher Entrance Sensor (S1)
- [D]: Paper Position Sensor Slide Motor (M7)
- [E]: Paper Position Sensor (S27)
- [F]: Paper Position Sensor Slide HP Sensor (S22)

The finisher entrance motor (M1) [A] drives the finisher entrance rollers [B] that feed paper from the copier into the finisher. The finisher entrance sensor (S1) [C] detects paper when it enters the finisher, and detects paper jams.

The paper position slide sensor motor (M7) [D] extends and retracts the paper position slide that holds the paper position sensor (S27) [E]. The paper position sensor detects the position of the paper edge. The detected position of the paper is used to calculate and position the punch unit for punching.

The paper position slide HP sensor (S22) [F] detects the paper position slide when it retracts and stops the paper position slide motor so the slide stops at its home position.

Punch Unit Movement

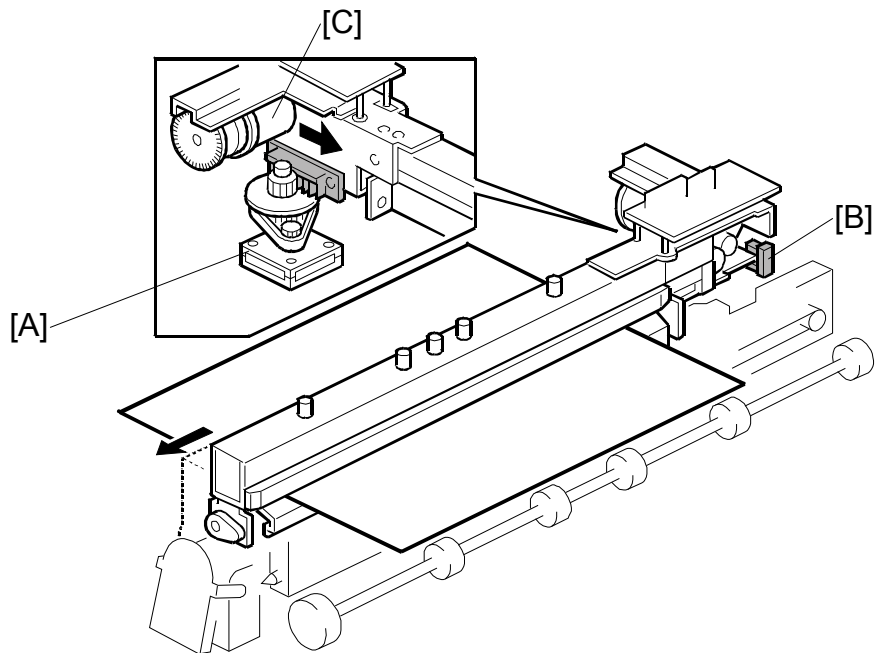

- [A]: Punch Movement Motor (M9)
- [B]: Punch Movement HP Sensor (S21)
- [C]: Punch Drive Motor (M24)

The punch movement motor (M9) [A] extends and retracts the punch unit to position it at the correct position for punching.

The punch movement HP sensor (S21) [B] detects the position when it retracts, switches off the punch position movement motor, and stops the punch unit at its home position.

The punch drive motor (M24) [C] fires the punches that punch holes in the paper below.

Punch Selection and Firing

- [A]: Punch Drive Motor (M24)
- [B]: Punch Encoder Wheel
- [C]: Punch Encoder Sensor (S24)
- [D]: Punch HP Sensor (S23)

The punch drive motor (M24) [A] turns the small, notched encoder wheel [B] through the gap in the punch encoder sensor [C] (S24). The sensor output is used to control the punch timing.

The timing for 2-hole punching [E] is different from 3-hole punching [F].

When the punch unit is at the punching position, the punch motor turns until the encoder detects the starting position for 2-hole or 3-hole punching.

- This is the '1' position in the diagrams (the top diagram is for 2-hole punching, and the bottom diagram is for 3-hole punching).

Then, the punch drive motor turns counter-clockwise to the '2' position. This movement punches the holes in the paper.

Then, the punch drive motor turns clockwise to the '1' position, to be ready for the next sheet of paper.

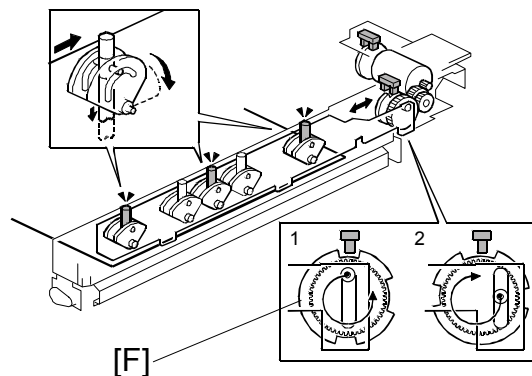
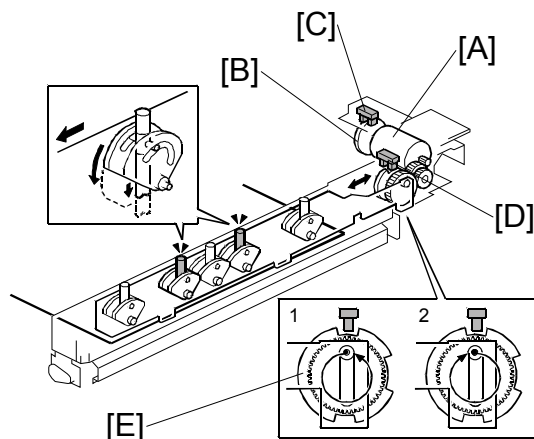

2.11.3 PUNCH HOPPER MECHANISM

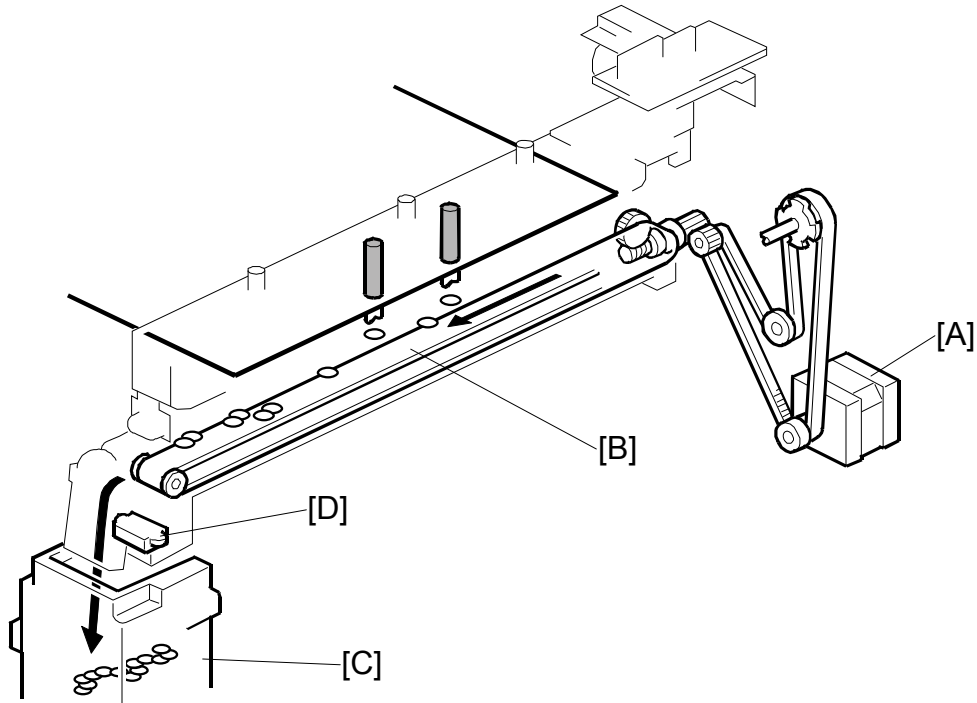

- [A]: Finisher Entrance Motor (M1)
- [B]: Punch Waste Belt
- [C]: Punch Waste Hopper
- [D]: Punch Hopper Full Sensor (S4)

The finisher entrance motor (M1) [A] drives the timing belt and gears that rotate the punch waste belt [B].

The punchouts fall from the punch unit onto the belt. The belt moves the punchouts to the front and dumps them in the punch waste hopper [C].

The punch hopper full sensor [D]:

- Signals that the hopper is full when it detects the top of the stack of punchouts that have collected in the hopper.
- It also detects when the punch hopper is set properly.

2.12 FINISHER JAM DETECTION

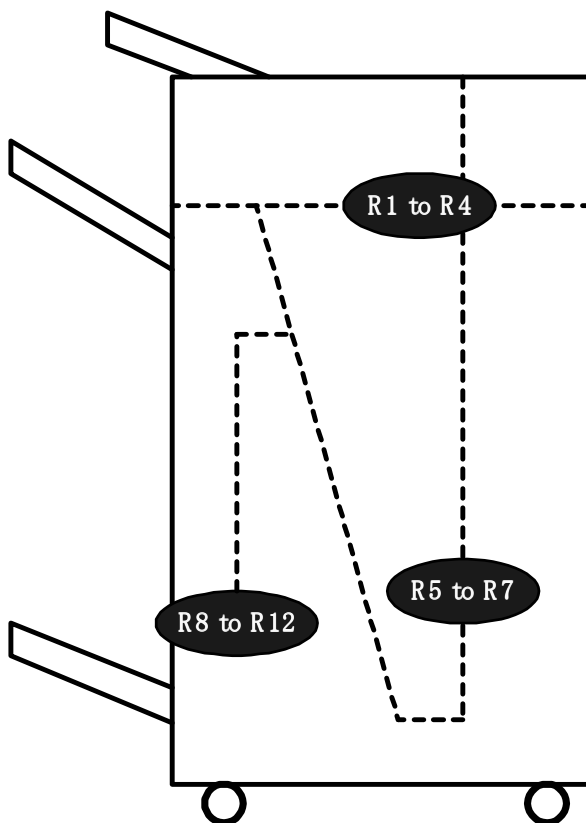

2000/3000
Sheet
Finisher
B700/B701

Display	Mode	Jam	What It Means
R1 to R3	Proof Shift Staple	Finisher entrance sensor late	After main machine exit sensor goes OFF, finisher entrance sensor does not go ON even after enough time to feed 450 mm.
		Finisher entrance sensor lag	After finisher entrance sensor goes ON, it does not go OFF after enough time to feed a sheet 1.5 times its length has elapsed.
R3	Proof	Proof exit sensor late	After finisher entrance sensor goes ON, proof exit sensor does not go ON even after enough time to feed 450 mm.
		Proof exit sensor lag	After finisher entrance sensor goes OFF, proof exit sensor does not go OFF even after enough time to feed 450 mm.
R4	Shift	Upper tray exit sensor late	After finisher entrance sensor goes ON, upper tray exit sensor does not go ON even after enough time to feed 485 mm.
		Upper tray exit sensor lag	After finisher entrance sensor goes OFF, upper tray exit sensor does not go OFF even after enough time to feed 650 mm.

FINISHER JAM DETECTION

Display	Mode	Jam	What It Means
R5 to R7	Staple	Pre-stack tray exit sensor lag	After finisher entrance sensor goes ON, pre-stack tray exit sensor does not go ON even after enough time to feed 650 mm.
		Pre-stack tray exit sensor late	After finisher entrance sensor goes ON, pre-stack tray exit sensor does not go OFF even after enough time to feed 1650 mm.
R8 to R12	Booklet Staple (B700 Only)	Fold unit entrance sensor late (S26)	The fold unit entrance sensor goes not go ON after enough time has elapsed to feed 1.5 times the length of the stack after the leading edge of the stack reaches the stack present sensor (S32).
		Fold unit exit sensor late (S31)	The fold unit exit sensor does not go ON after enough time has elapsed for the stack to feed 1.5 times its length from the fold position.
		Fold unit exit sensor lag (S31)	After the fold unit exit sensor goes ON, it does not go OFF after enough time has elapsed to feed 442.9 mm.