



Brother Laser Printer

SERVICE MANUAL

MODEL:
HL-1110/1111/1112/1118



Read this manual thoroughly before maintenance work.
Keep this manual in a convenient place for quick and easy reference at all times.

May 2013
SM-PRN092
84UE03
(2)

TRADEMARKS

The Brother logo is a registered trademark of Brother Industries, Ltd.

Brother is a trademark of Brother Industries, Ltd.

Microsoft, Windows, Windows Vista, Windows Server, Outlook and Internet Explorer are either registered trademarks or trademarks of Microsoft Corporation in the United States and/or other countries.

Apple, Macintosh, Safari and Mac OS are trademarks of Apple Inc., registered in the U.S. and other countries.

Linux is the registered trademark of Linus Torvalds in the U.S. and other countries.

Intel and Pentium are trademarks of Intel Corporation in the U.S. and/or other countries.

Adobe, Photoshop and Reader are either registered trademarks or trademarks of Adobe Systems Incorporated in the United States and/or other countries.

Each company whose software title is mentioned in this manual has a Software License Agreement specific to its proprietary programs.

Any trade names and product names of companies appearing on Brother products, related documents and any other materials are all trademarks or registered trademarks of those respective companies.

© Copyright Brother 2013

All rights reserved.

No part of this publication may be reproduced in any form or by any means without permission in writing from the publisher.

All other product and company names mentioned in this manual are trademarks or registered trademarks of their respective holders.

Specifications are subject to change without notice.

Model	All models
Machine life	50,000 pages (A4/Letter size) or 5 years
Part life (Fuser unit)	Up to 50,000 pages
Part life (Laser unit)	Up to 50,000 pages
Maximum monthly volume	Up to 10,000 pages

CONTENTS

REGULATION	iv
SAFETY INFORMATION.....	vi
CHAPTER 1 TROUBLESHOOTING	
1. INTRODUCTION	1-1
1.1 Checks before Commencing Troubleshooting.....	1-1
2. OVERVIEW	1-3
2.1 Cross-section Drawing.....	1-3
2.2 Paper Feeding	1-4
2.3 Operation of Each Part.....	1-5
2.4 Block Diagram	1-6
2.5 Main Components.....	1-7
3. LED DISPLAY	1-8
3.1 LED Display when Operator Call Occurs.....	1-8
3.2 LED Display when Service Call Occurs.....	1-10
3.3 Error Messages for Maintenance Printing	1-13
3.4 Error Display when Service Call Occurs.....	1-14
3.5 Image Defects.....	1-15
4. ERROR CAUSE AND REMEDY	1-16
4.1 Troubleshooting for Paper Feeding Problems	1-16
4.1.1 No paper is fed from paper tray.....	1-16
4.1.2 Paper becomes wrinkled	1-17
4.1.3 Paper is curled	1-17
4.1.4 Paper is jammed	1-18
4.2 Troubleshooting According to Image Defect.....	1-19
4.2.1 Light.....	1-19
4.2.2 Faulty registration.....	1-20
4.2.3 Dark.....	1-20
4.2.4 Poor fixing	1-21
4.2.5 Completely blank.....	1-21
4.2.6 Image distortion.....	1-22
4.2.7 All black.....	1-22
4.2.8 Dirt on the back of paper.....	1-23
4.2.9 Vertical streaks.....	1-23
4.2.10 Black vertical streaks on a light background	1-23
4.2.11 Black horizontal stripes	1-24
4.2.12 White vertical streaks	1-24
4.2.13 White horizontal streaks	1-25

4.2.14	Faint print	1-25
4.2.15	White spots.....	1-26
4.2.16	Black spots	1-26
4.2.17	Black band.....	1-27
4.2.18	Downward fogging of solid color	1-27
4.2.19	Horizontal lines.....	1-27
4.2.20	Ghost.....	1-28
4.2.21	Fogging	1-28
4.3	Troubleshooting for Software Problems	1-29
4.3.1	Cannot print data.....	1-29
4.4	Troubleshooting for Toner and Drum Problems	1-30
4.4.1	Replaced the toner cartridge with a new one but still seeing LED display prompting toner cartridge replacement.	1-30
4.4.2	Toner cartridge cannot be detected	1-30
4.4.3	Failed to detect toner cartridge.....	1-30
4.4.4	Drum error.....	1-31
4.4.5	Drum unit cannot be detected.	1-31
4.4.6	Replace drum unit (replaced the drum unit with a new one but still seeing LED display prompting toner cartridge replacement)	1-31
4.5	Troubleshooting for Fuser Unit Problems.....	1-32
4.5.1	Fuser unit failure.....	1-32
4.6	Troubleshooting for Laser Unit Problems	1-32
4.6.1	Laser unit failure.....	1-32
4.7	Troubleshooting for Other Problems.....	1-33
4.7.1	Machine does not turn ON or LED does not light.....	1-33
4.7.2	Top cover is open.....	1-33
4.7.3	Unusual noise is coming from the machine.....	1-33
4.7.4	Memory failure.....	1-34
4.7.5	Print failure	1-34
4.7.6	Paper size failure.....	1-34
4.7.7	Main motor failure.....	1-34
4.7.8	Power supply voltage failure	1-34
4.7.9	High voltage power supply PCB failure	1-35
4.7.10	Main PCB failure	1-35

CHAPTER 2 DISASSEMBLY/REASSEMBLY

1. PACKING	2-1
2. TIGHTENING TORQUE LISTS	2-2
3. LUBRICATION.....	2-3
4. OVERVIEW OF GEARS.....	2-3
5. HARNESS ROUTING.....	2-4
6. DISASSEMBLY FLOW CHART.....	2-7

7. DISASSEMBLY PROCEDURE.....	2-8
7.1 Preparation	2-8
7.2 Back cover.....	2-9
7.3 Top cover ASSY	2-10
7.4 Tray cover ASSY.....	2-13
7.5 Side cover L.....	2-14
7.6 Side cover R.....	2-15
7.7 Low voltage power supply PCB unit	2-16
7.8 Fuser unit.....	2-18
7.9 High voltage power supply PCB ASSY.....	2-19
7.10 Main PCB ASSY	2-20
7.11 Front cover.....	2-21
7.12 Laser unit.....	2-22
7.13 Motor encoder PCB ASSY.....	2-24
7.14 Eject sensor PCB ASSY	2-25
7.15 Paper feed/paper printing position sensor PCB ASSY	2-26
7.16 New toner sensor PCB ASSY.....	2-27

CHAPTER 3 ADJUSTING AND UPDATING SETTINGS AS REQUIRED AFTER PARTS REPLACEMENT

1. IF YOU REPLACE THE MAIN PCB ASSY.....	3-1
1.1 Installing Firmware (Main Firmware)	3-2
1.1.1 Checking firmware version	3-2
1.1.2 Installing firmware (Main program).....	3-2
1.2 Setting by Country	3-3
1.3 Setting Serial Number and Entering Adjusted Value of Laser Unit.....	3-5
2. IF YOU REPLACE THE LASER UNIT.....	3-6
2.1 Entering Adjusted Value of Laser Unit.....	3-7
3. IF YOU REPLACE THE LOW VOLTAGE POWER SUPPLY PCB UNIT.....	3-8
3.1 Resetting Irregular Power Supply Detection Counter.....	3-8

CHAPTER 4 SERVICE FUNCTIONS

1. PRINTING PRINTER SETTINGS.....	4-1
2. RESETTING DRUM COUNTER.....	4-3
3. SWITCHING BETWEEN CONTINUE MODE AND STOP MODE	4-3
4. TEST PRINTING	4-4
5. MAINTENANCE PRINTING	4-5
6. RESETTING TONER MANUALLY.....	4-7

APPENDIX 1 SERIAL NUMBERING SYSTEM

APPENDIX 2 DELETING USER SETTING INFORMATION

REGULATION

■ Declaration of Conformity (Europe only)

We, Brother Industries, Ltd.

15-1, Naeshiro-cho, Mizuho-ku, Nagoya 467-8561 Japan

declare that this product is in conformity with the essential requirements of all relevant directives and regulations applied within the European Community.

The Declaration of Conformity (DoC) can be downloaded from our website. Visit <http://solutions.brother.com/> and:

→ select “Europe”

→ select your country

→ select your model

→ select “Manuals” and your language, then click “Search”

→ select Declaration of Conformity

→ click “Download”.

■ IEC60825-1:2007 Specification (For 220-240V models only)

This product is a Class 1 laser product as defined in IEC60825-1:2007 specifications.

The label shown below is attached in countries where required.

This product has a Class 3B Laser Diode which emits invisible laser radiation in the Laser Unit. The Laser Unit should not be opened under any circumstances.



Internal Laser radiation

Wave Length: 770 - 800 nm

Output: 25 mW max.

Laser Class: Class 3B

WARNING

Use of controls, adjustments or performance of procedures other than those specified in this manual may result in hazardous radiation exposure.

■ Disconnect Device

CAUTION

This product must be installed near an electrical socket that is easily accessible. In case of emergencies, you must disconnect the power cord from the electrical socket to shut off power completely.

■ **Recycling Information in accordance with the WEEE (2002/96/EC) and Battery (2006/66/EC) Directives**



Product mark



Battery mark

European Union only

The product/battery is marked with one of the above recycling symbols. It indicates that at the end of the life of the product/battery, you should dispose of it separately at an appropriate collection point and not place it in the normal domestic waste stream.

■ **International ENERGY STAR[®] Qualification Statement**

The purpose of the International ENERGY STAR[®] Program is to promote the development and popularization of energy-efficient office equipment.

As an ENERGY STAR[®] Partner, Brother Industries, Ltd. has determined that this product meets the ENERGY STAR[®] specifications for energy efficiency.



SAFETY INFORMATION

WARNING

WARNING indicates a potentially hazardous situation which, if not avoided, could result in death or serious injuries.

CAUTION

CAUTION indicates a potentially hazardous situation which, if not avoided, may result in minor or moderate injuries.

IMPORTANT

IMPORTANT indicates a potentially hazardous situation which, if not avoided, may result in damage to property or loss of product functionality.

 Prohibition icons indicate actions that must not be performed.

 Electrical Hazard icons alert you to possible electrical shock.

 Fire Hazard icons alert you to the possibility of fire.

 Hot Surface icons warn you not to touch product parts that are hot.

Note Notes tell you how you should respond to a situation that may arise or give tips about how the operation works with other features.

■ To use the Machine Safely

Please keep these instructions for later reference and read them before attempting any maintenance. If you do not follow these safety instructions, there is a possibility of a fire, electrical shock, burn or suffocation.

WARNING

ELECTRICAL HAZARDS

Failure to follow the warnings in this section may create the risk of an electrical shock. In addition, you could create an electrical short, which may create the risk of a fire.



There are high voltage electrodes inside the product. Before you access the inside of the product, including for routine maintenance such as cleaning, make sure you have unplugged the power cord from the AC power outlet. Never push objects of any kind into this product through cabinet slots, since they may touch dangerous voltage points or short out parts.

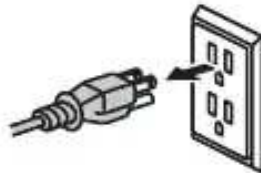

DO NOT handle the plug with wet hands.

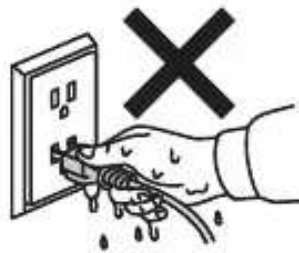

DO NOT use this product during an electrical storm.



Always make sure the plug is fully inserted. DO NOT use the product or handle the cord if the cord has become worn or frayed.



This product should be connected to an AC power source within the range indicated on the rating label. DO NOT connect it to a DC power source or inverter.



POWER CORD SAFETY:

- Use only the power cord supplied with this product.
- DO NOT allow anything to rest on the power cord. DO NOT place this product where people can walk on the cord.
- DO NOT place this product in a position where the cord becomes stretched, or where strain is otherwise put on the cord. Doing so may cause the cord to become worn or frayed.
- Brother strongly recommends that you DO NOT use any type of extension cord.



- DO NOT put a toner cartridge and drum unit assembly into a fire. It could explode, resulting in injuries.
- DO NOT use flammable substances, any type of spray, or an organic solvent/liquid containing alcohol or ammonia to clean the inside or outside of the product. Doing so could cause a fire or electrical shock. Instead, use only a dry, lint-free cloth.

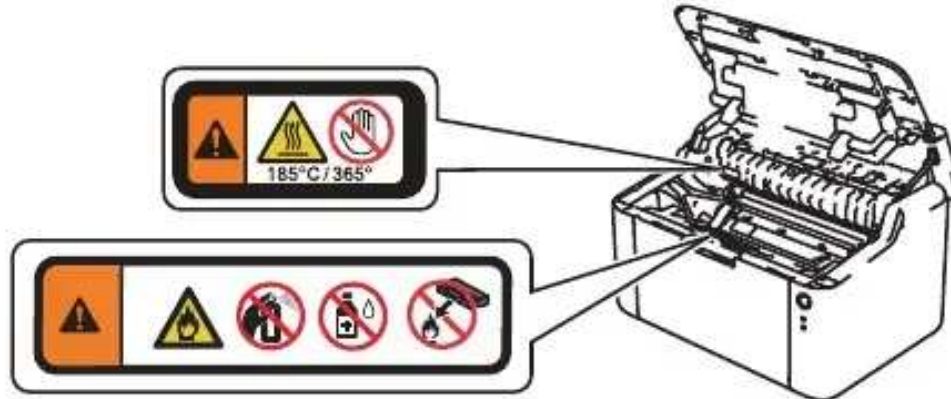

DO NOT attempt to operate this product with a paper jam or with stray pieces of paper inside the product. Prolonged contact of the paper with the drum unit could cause a fire.



DO NOT use a vacuum cleaner to clean up scattered toner. Doing this might cause the toner dust to ignite inside the vacuum cleaner, potentially starting a fire. Please carefully clean the toner dust with a dry, lint-free soft cloth and dispose of it according to local regulations.



HOT SURFACE

After you have just used the product, some internal parts of the product will be extremely hot. Wait at least 15 minutes for the product to cool down before you touch the internal parts of the product.

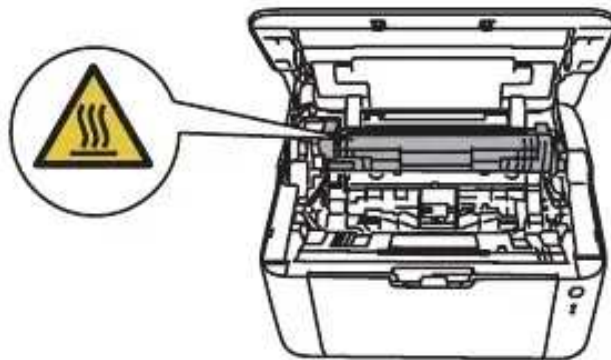

CAUTION

Lightning and power surges can damage this product! We recommend that you use a quality surge protection device on the AC power line, or unplug the machine during a lightning storm.

Violently closing the top cover without mounting the toner cartridge and the drum unit can damage this product.

■ **Caution for Laser Product (WARNHINWEIS für Laser drucker)**

CAUTION: When the machine during servicing is operated with the cover open, the regulations of VBG 93 and the performance instructions for VBG 93 are valid.

CAUTION: In case of any trouble with the laser unit, replace the laser unit itself. To prevent direct exposure to the laser beam, do not try to open the enclosure of the laser unit.

ACHTUNG: Im Falle von Störungen der Lasereinheit muß diese ersetzt werden. Das Gehäuse der Lasereinheit darf nicht geöffnet werden, da sonst Laserstrahlen austreten können.

<Location of the laser beam window>

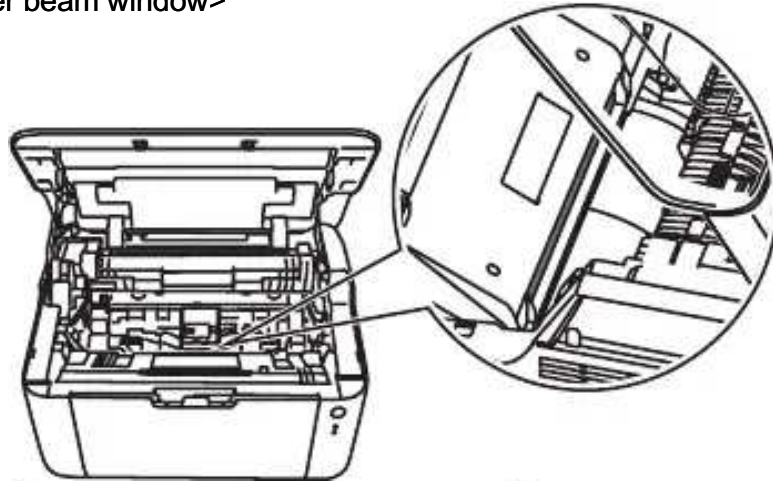

■ **Additional Information**

When servicing the optical system of the machine, be careful not to place a screwdriver or other reflective object in the path of the laser beam. Be sure to take off any personal accessories such as watches and rings before working on the machine. A reflected beam, though invisible, can permanently damage the eyes.

Since the beam is invisible, the following caution in print is attached on the laser unit.



■ Troubleshooting/Disassembling/Assembling Notes

- To avoid creating secondary problems by mishandling, follow the warnings and precautions below during maintenance work.
- Be careful not to lose screws, washers, or other parts removed.
- Be sure to apply grease to applicable positions specified in this manual.
- When using soldering irons or other heat-generating tools, take care not to accidentally damage parts such as wires, PCBs and covers.
- Static electricity charged in your body may damage electronic parts. When transporting PCBs, be sure to wrap them in conductive sheets.
- When replacing PCBs and all the other related parts, put on a grounding wrist band and perform the job on a static mat. Also take care not to touch the conductor sections on the flat cables or on the wire harness.
- After disconnecting flat cables, check that each cable is not damaged at its end or short-circuited.
- When connecting flat cables, do not insert them at an angle. After insertion, check that the cables are not inserted at an angle.
- When connecting or disconnecting harnesses, hold the connector body, not the cables. If the connector is locked, release it first.
- After a repair, check not only the repaired portion but also harness treatment. Also check that other related portions are functioning properly.
- Be careful not to close the top cover forcefully without mounting the toner cartridge and the drum unit. It can damage the machine.
- After assembly, it is recommended to conduct a dielectric test and continuity test.
- Be sure to unplug the AC cord before removing any covers or PCBs, adjusting the machine, or conducting continuity tests using a tester.
- The insulation sheet should not be damaged.

CHAPTER 1 TROUBLESHOOTING

1. INTRODUCTION

Troubleshooting is a collection of solution procedures that service personnel should follow if an error or malfunction occurs in the machine. It is difficult to determine troubleshooting procedures for all possible problems that may occur in the future. Therefore, this chapter describes typical problems and recovery procedures for these. These will help service personnel identify and repair other similar defective sections.

Be sure to observe the [Troubleshooting/Disassembling/Assembling Notes](#) during maintenance work for troubleshooting.

1.1 Checks before Commencing Troubleshooting

■ Operating environment

- (1) The machine is placed on a flat, stable surface.
- (2) The machine is used in a clean environment where the temperature is 10°C (50°F) to 32.5°C (90.5°F), and the relative humidity is maintained between 20% and 80%.
- (3) The machine is not exposed to direct sunlight, excessive heat, moisture, or dust.
- (4) Hold the machine level while moving it.

■ Power supply

- (1) Power described on the rating label attached on the machine is supplied. Power fluctuation should be within $\pm 10\%$ of the rated voltage.
- (2) The AC input power supply is within the regulated value.
- (3) The cables and harnesses are connected correctly.
- (4) The fuses are not blown.

■ Paper

- (1) The recommended type of paper is being used.
- (2) The document is not damp.
- (3) Short-grained paper or acid paper is not used.

■ Consumable parts

- (1) The drum unit (including toner cartridge) is set correctly.

■ Others

(1) Condensation

When the machine is moved to a warm room from a cold location, condensation may occur inside the machine, causing various problems as listed below.

- Condensation on the surface of optical devices such as the lens, reflecting mirror and protection glass may cause light print image.
- If the exposure drum is cold, the electrical resistance of the photosensitive layer is increased, making it impossible to obtain the correct print density.
- Condensation on the charge unit may cause corona charge leakage, resulting in image defects.
- Condensation on the plate may cause paper feed problems.

If condensation has formed in the machine, leave the machine for at least two hours until it reaches room temperature.

If the drum unit is unpacked soon after it is moved to a warm room from a cold location, condensation may occur inside the unit which may cause printing failure.

Leave the drum unit for one or two hours until it reaches room temperature, and then unpack it.

(2) Low temperature

The motor may not operate normally in a cold environment because too much load is applied to each drive. In this case, increase the room temperature.

■ Cleaning

Use a soft lint-free cloth.

WARNING

DO NOT use any flammable spray or flammable solvent such as alcohol, benzine, or thinner to clean the machine. **DO NOT** use these articles near the machine.



2. OVERVIEW

2.1 Cross-section Drawing

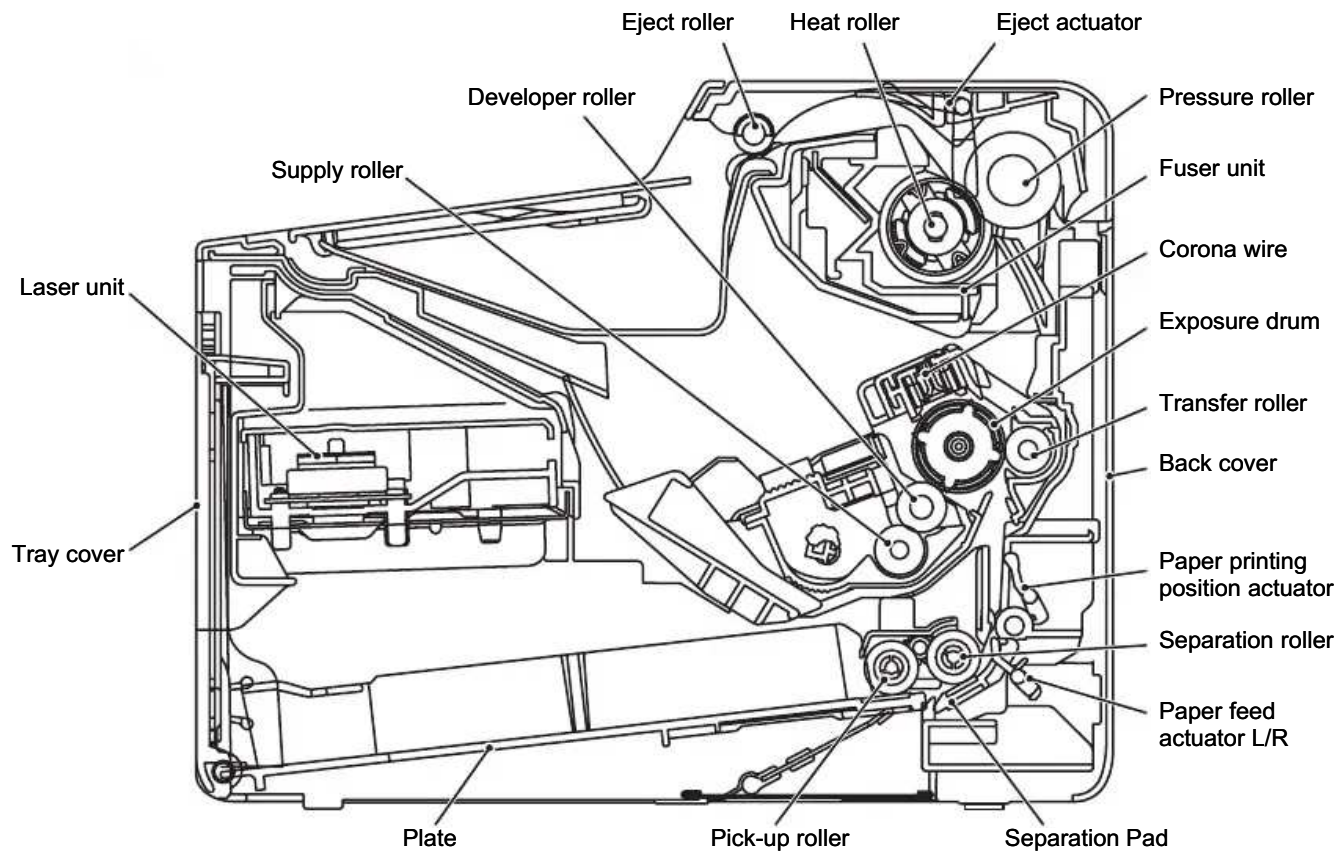

Fig. 1-1

1-3

Confidential

2.2 Paper Feeding

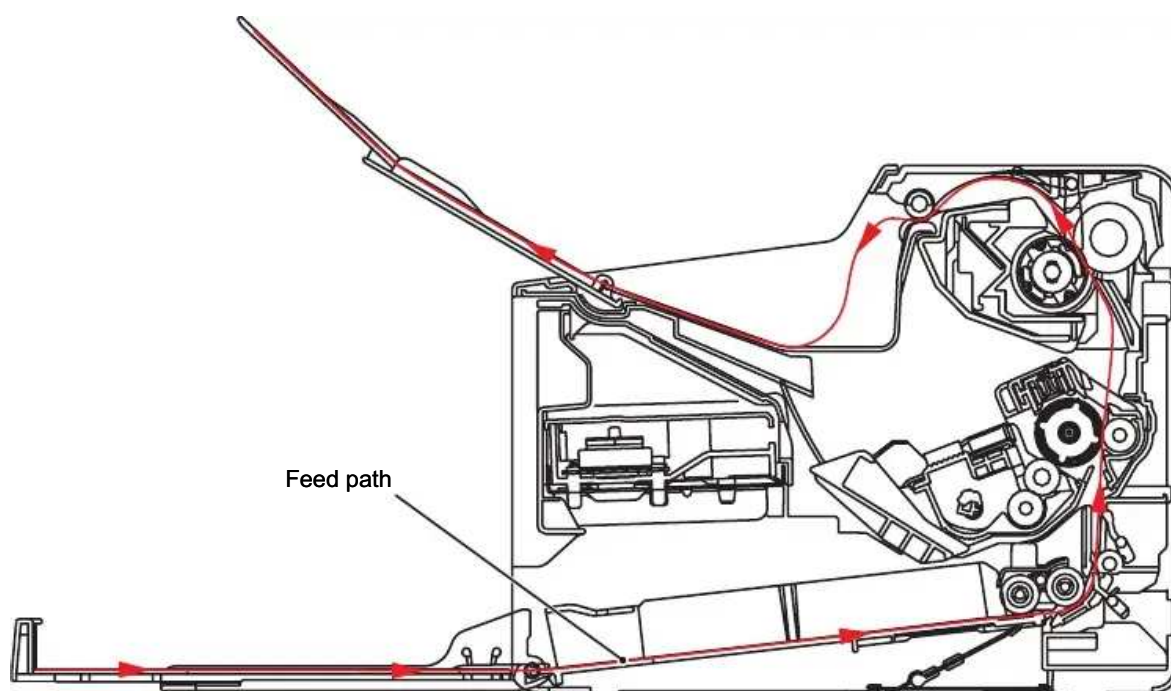

Fig. 1-2

1-4

Confidential

2.3 Operation of Each Part

Part name	Operation
Pick-up roller	Feeds paper from the paper tray.
Separation roller / Separation pad	Separates paper fed from paper tray into single sheets.
Paper feed actuator L/R (Paper feed sensor L/R)	Determines if the sheet of paper is of printable size. Detects paper jams in the front section of the machine.
Paper printing position actuator (Paper printing position sensor)	Detects the front edge of paper to adjust the paper printing position. Detects paper jams in the center section of the machine. Detects the front and rear edges of paper to determine the paper size.
Heat roller Pressure roller	Fuses the toner transferred to paper by heat and pressure, and feeds paper to the eject roller.
Eject actuator (Eject sensor)	Determines whether paper is ejected from the fuser unit. Detects paper jams in the rear section of the machine.
Eject roller	Feeds paper to the output tray.

2.4 Block Diagram

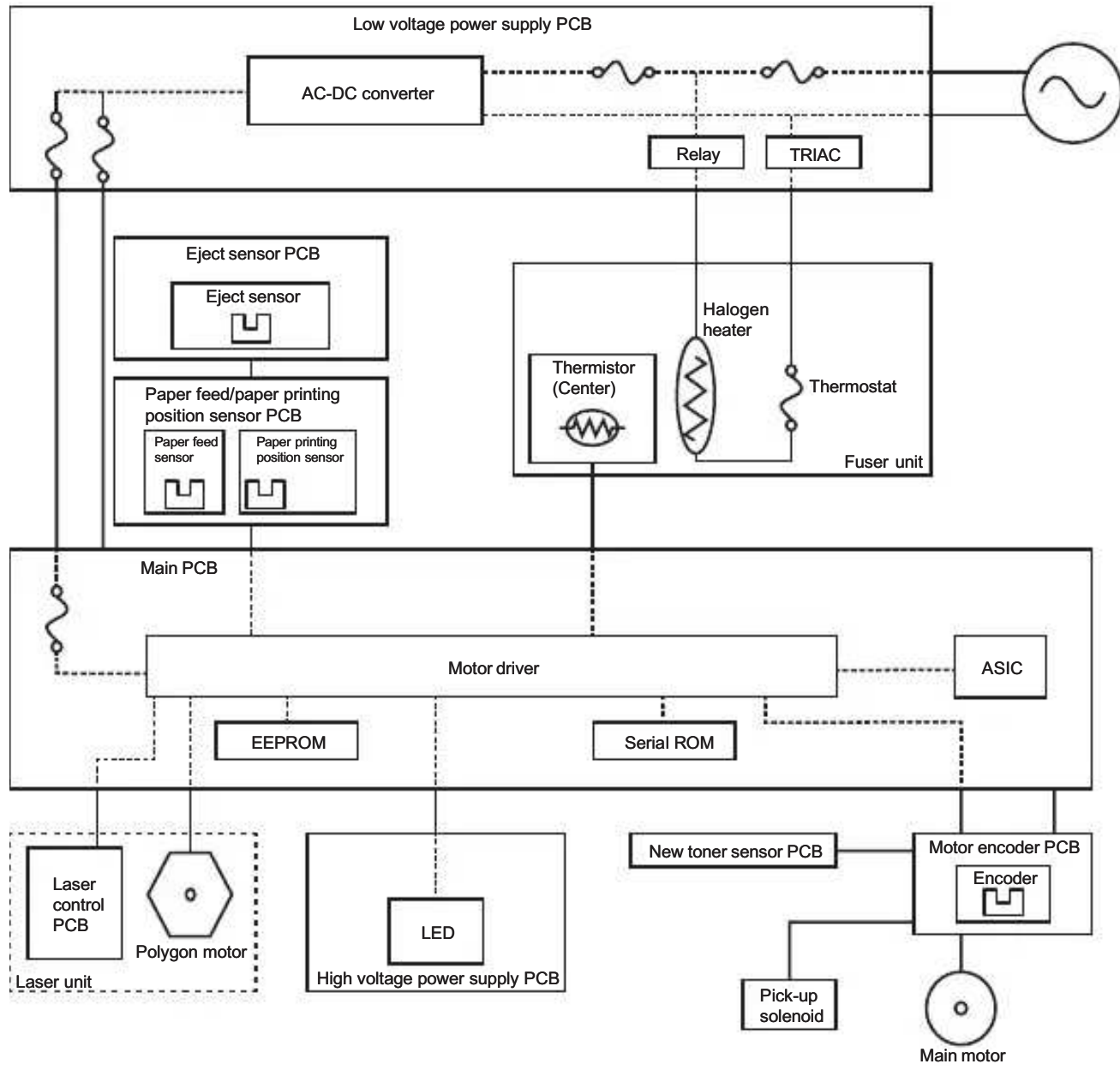

Fig. 1-3

2.5 Main Components

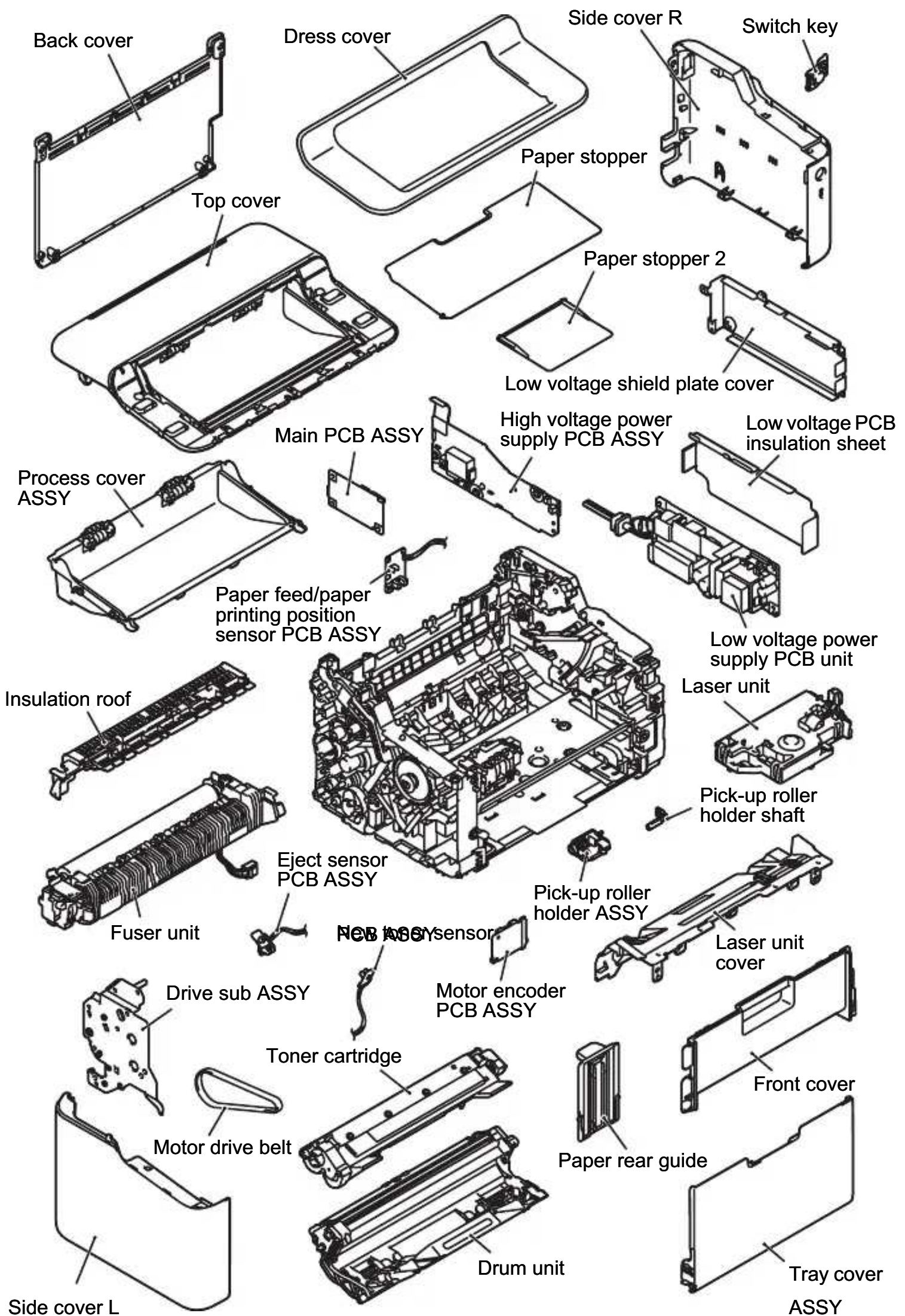







Fig. 1-4





3. LED DISPLAY

3.1 LED Display when Operator Call Occurs

Determine the message details according to the LED display on the control panel. Refer to the page shown in the “Refer to:” column in the table below to take appropriate measures. Error LED indications are automatically cleared after measures are taken. If not automatically cleared, press the  button to reset the machine.

LED status in the table below: Unlit  Lit  Flashing 

LED	LED display	Type of problem	No. of times the  button is pressed to reset	Refer to:
	Error LED flashes once every 0.5 seconds and stays unlit for a second.	Dot count or developer roller counter of the toner is reaching or has reached the upper limit (when setting toner continuous printing).	N/A	4.4.1
	Error LED flashes three times every 0.5 seconds and stays unlit for a second.	The number of rotations of the drum is reaching or has reached the upper limit.	N/A	4.4.6
	Error LED flashes once every 0.5 seconds and stays unlit for a second.	Dot count or developer roller counter of the toner has reached the upper limit (when setting toner stop mode).		4.4.1
		No toner cartridge		4.4.2
		Dot count or developer roller counter of the toner has reached the upper limit or forced outage level when the toner continuous printing is set.		4.4.1
	Error LED flashes twice every 0.5 seconds and stays unlit for a second.	The paper feed sensor does not detect paper pass within the specified time while printing.		4.1.4
		The paper printing position sensor does not detect paper pass within the specified time after the paper feed sensor detected paper pass.		4.1.4





















LED	LED display	Type of problem	No. of times the  button is pressed to reset	Refer to:
	Error LED flashes twice every 0.5 seconds and stays unlit for a second.	The eject sensor does not detect paper pass within the specified time after the paper printing position sensor detected paper pass.		4.1.4
		Open top cover is detected when the power is turned ON.		4.7.2
		The paper feed sensor detected that the paper set in the paper tray was smaller than the specified size.		4.7.6
	Error LED flashes three times every 0.5 seconds and stays unlit for a second.	Dirt on corona wire of the drum unit.		4.4.4
		No drum unit set.		4.4.5
	Error LED flashes four times every 0.5 seconds and stays unlit for a second.	New toner sensor could not detect the new toner cartridge correctly.		4.4.3
		Top cover is open.		4.7.2
		There is insufficient memory to expand PC print data.		4.7.4



























3.2 LED Display when Service Call Occurs

















Two LEDs flash when unresolvable errors occur. Pressing the  button allows you to identify the location of the problem based on the combination of the LED status: lit, flashing or unlit.

In the event that a service call occurs, instruct end users to turn the power switch OFF and then ON again after several seconds. If the service call still occurs, refer to the page shown in the “Refer to:” column in the table below to take appropriate measures.

The number in the “number of times the  button is pressed” column indicates number of times the LED flashes every 0.5 seconds.

LED			Type of problem	Refer to:
When error occurs:	Press the  button once	Press the  button twice		
 Flashes every 0.5 seconds	 1	 1	Irregular power supply detection error	4.7.8
 Flashes every 0.5 seconds	 1	 2	Irregular power supply detection error (More than 100 times detected in total)	4.7.8
 Flashes every 0.5 seconds	 2	 1	High voltage power supply PCB failure	4.7.9
 Flashes every 0.5 seconds	 3	 2	The center thermistor of the fuser unit detected a temperature fall greater than the specified value within the specified time.	4.5.1
 Flashes every 0.5 seconds	 3	 3	The center thermistor of the fuser unit detected a sharp temperature gradient greater than the specified value within the specified time.	4.5.1
 Flashes every 0.5 seconds	 3	 4	The center thermistor of the fuser unit detected a temperature rise greater than the specified value within the specified time.	4.5.1

LED			Type of problem	Refer to:
When error occurs:	Press the  button once	Press the  button twice		
 Flashes every 0.5 seconds	 3	 5	After the heat unit was heated normally, the center thermistor of the fuser unit detected a temperature lower than the specified value.	4.5.1
 Flashes every 0.5 seconds	 3	 6	The center thermistor of the fuser unit detected a temperature higher than the specified value.	4.5.1
 Flashes every 0.5 seconds	 3	 7	The center thermistor of the fuser unit has not reached the specified temperature within the specified time.	4.5.1
 Flashes every 0.5 seconds	 3	 10	Detected "Heater 100% heated" continuously within the specified time while printing.	4.5.1
 Flashes every 0.5 seconds	 4	 2	DRAM failure in the main PCB	4.7.4
 Flashes every 0.5 seconds	 4	 3	Write error in the NVRAM of the main PCB	4.7.4
 Flashes every 0.5 seconds	 4	 4	Read error in the NVRAM of the main PCB	4.7.4
 Flashes every 0.5 seconds	 4	 5	BUS error in the NVRAM of the main PCB	4.7.4

LED			Type of problem	Refer to:
When error occurs:	Press the  button once	Press the  button twice		
 Flashes every 0.5 seconds	 5	 1	BD signal detection error of the laser unit	4.6.1
 Flashes every 0.5 seconds	 5	 2	Lock signal detection error of the laser unit	4.6.1
 Flashes every 0.5 seconds	 6	 1	Main motor error	4.7.7
 Flashes every 0.5 seconds	 7	 1	Program error	4.7.10
 Flashes every 0.5 seconds	 8	 1	Engine control error	4.7.10

3.3 Error Messages for Maintenance Printing

(Refer to "5. MAINTENANCE PRINTING" in chapter 4.)

Refer to the page shown in the "Refer to:" column in the table below to take appropriate measures when the following error messages are displayed on maintenance printing.

Error Message	Refer to:
CARTRIDGE ERROR	4.4.2, 4.4.3
COOLING DOWN	4.7.5
DRUM ! DRUM ERROR	4.4.4, 4.4.5
DRUM END SOON	4.4.6
ERROR E51 (LASER BD MALF)	4.6.1
ERROR E52 (SCANNER MALF)	4.6.1
ERROR E54 (MOTOR MALF)	4.7.7
ERROR E55 (HIGH VOL MALF)	4.7.9
ERROR H63 (DRAM ERROR)	4.4.4, 4.4.5
ERROR H66 (NV-W ERROR)	4.7.4
ERROR H67 (NV-R ERROR)	4.7.4
ERROR H68 (NV-B ERROR)	4.7.4
ERROR H75 (ZEROCROSS ERROR)	4.7.8
ERROR S01 (MAIN PCB ERROR)	4.7.10
JAM INSIDE 1	4.1.4
JAM INSIDE 2	4.1.4
JAM INSIDE 3	4.1.4
JAM TRAY	4.1.4
MEMORY FULL	4.7.4
NO DRUM	4.4.5
NO PAPER	4.1.1
NO TONER	4.4.2
PRINT UNABLE ZC (ZEROCROSS ERROR)	4.7.8
REPLACE DRUM	4.4.5
REPLACE TONER	4.4.1
TONER ENDED	4.4.6
TONER LOW	4.4.1
TOP COVER OPEN	4.7.2
WRONG PAPER TYPE	4.7.6

3.4 Error Display when Service Call Occurs

If the LED for service call is not lit, acquire error status by performing Printer Setting print or Maintenance printing. If printing is not operable, use status monitor to acquire Status code.

Error indication (Printer Settings print)	Error indication (Maintenance printing)	Status code	Type of problem	Refer to:
ERROR S01	ERROR S01	40057	Main PCB failure	4.7.10
ERROR E49	FUSER MF 2	50010	Fuser unit failure	4.5.1
ERROR E50	FUSER MF	50003		4.5.1
SELF-DIAGNOSTIC	FUSER ERR	50076		4.5.1
ERROR E51	LASER BD MALF	50004	Laser beam detection error	4.6.1
ERROR E52	SCANNER MALF	50005	Scanner motor failure	4.6.1
ERROR E54	MOTOR MALF	60004	Main motor failure	4.7.7
ERROR E55	HIGH VOL MALF	50000	High voltage power supply PCB failure	4.7.9
ERROR H63	ERROR H63	50002	Main PCB failure	4.4.4, 4.4.5
ERROR H66	NV-W ERROR	30035		4.7.4
ERROR H67	NV-R ERROR	30035		4.7.4
ERROR H68	NV-B ERROR	30035		4.7.4
ERROR H75	ERROR H75	60030	Irregular power supply detection error 2	4.7.8
PRINT UNABLE ZC	PRINT UNABLE ZC	60182	Irregular power supply detection error 1	4.7.8

■ How to Display Status Code with Status Monitor

- (1) Connect the computer to the machine with the USB cable.
- (2) Double-click the Status Monitor on the computer screen.

Dialog box below appears.



- (3) Double-click the Status Monitor icon.

Log data below appears.

Check Status fields.

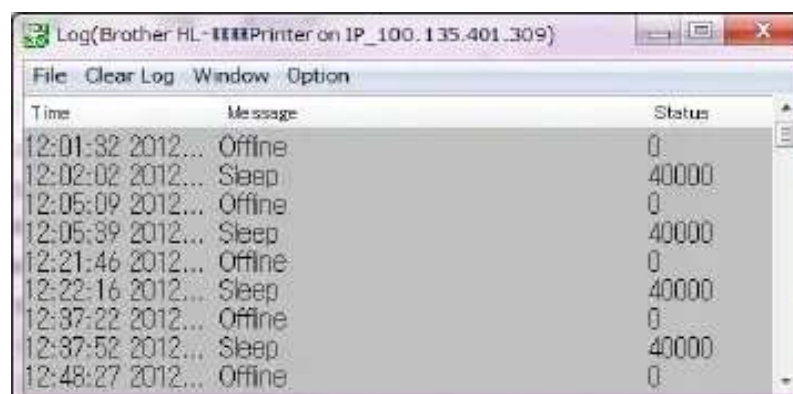

3.5 Image Defects

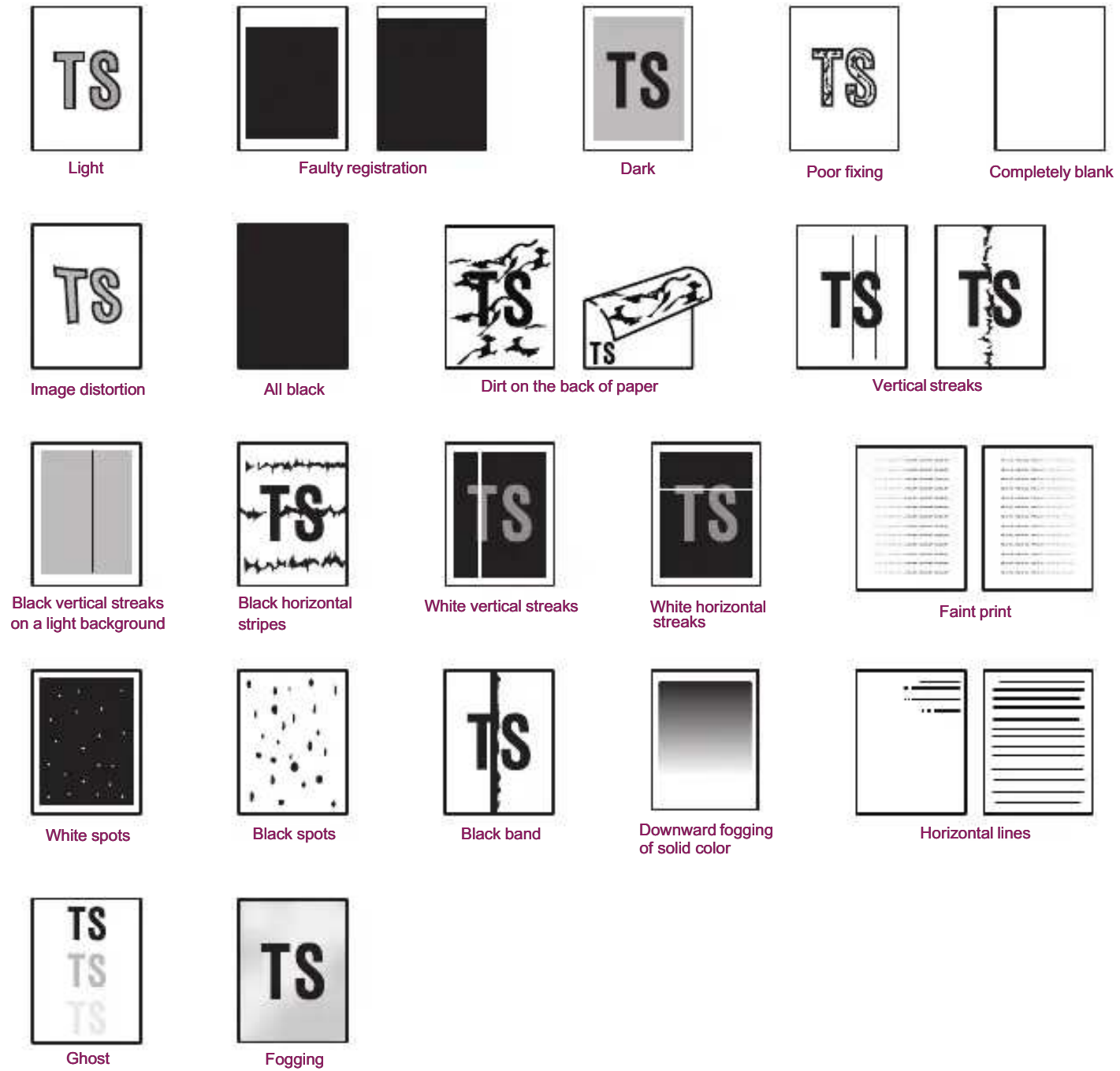

Fig. 1-5

4. ERROR CAUSE AND REMEDY

4.1 Troubleshooting for Paper Feeding Problems

End users can solve problems related to paper feeding as long as they follow the User Check items.

If the problem still cannot be solved, implement each procedure according to the step numbers in the tables below.

4.1.1 No paper is fed from paper tray

<User Check>

- Check that the paper is set in the paper tray correctly.
- Check that there is not too much paper set in the paper tray.
- Flip over the paper in the paper tray or rotate the paper 180 degrees.
- Check that the thickness of the paper is within the standard.
- Check that the size of the paper is within the standard.
- Flip through the paper and reset it in the paper tray.

Step	Cause	Remedy
1	Foreign object inside the machine	Remove the foreign object.
2	Gears around the plate up plate coming off	Reattach gears around the plate up plate.
3	Attachment failure of the motor drive belt	Reattach the motor drive belt.
4	Attachment failure of the laser shutter arm	Reattach the laser shutter arm.
5	Connection failure of the main motor harness	Reconnect the main motor harness.
6	Connection failure of the motor encoder PCB flat cable	Reconnect the motor encoder PCB flat cable.
7	Connection failure of the pick-up solenoid harness	Reconnect the pick-up solenoid harness.
8	Motor drive belt failure	Replace the motor drive belt.
9	Motor encoder PCB failure	Replace the motor encoder PCB ASSY.
10	Low voltage power supply PCB failure	Replace the low voltage power supply PCB unit.
11	Laser unit failure	Replace the laser unit.
12	Main PCB failure	Replace the main PCB ASSY.

4.1.2 Paper becomes wrinkled

<User Check>

- Check that the paper is set in the paper tray correctly.
- Flip over the paper in the paper tray or rotate the paper 180 degrees.
- Adjust the paper guide according to the paper size.
- Check that the thickness of the paper is within the standard.
- Check that the paper is not damp.
- Check that there is no dust on the fuser unit.
- Check whether the paper type is appropriate.

Step	Cause	Remedy
1	Fuser unit failure	Replace the fuser unit.

4.1.3 Paper is curled

<User Check>

- Select "Reduce Paper curl mode" in the driver.
- Check that the thickness of the paper is within the standard.

4.1.4 Paper is jammed

■ Paper is jammed in the paper tray section

<User Check>

- Rotate the paper 180 degrees in the paper tray.
- Flip through the paper and reset it in the paper tray.
- Check that the thickness of the paper is within the standard.
- Check that there is no label stuck in the paper feed path.

Step	Cause	Remedy
1	Foreign object in the front of the machine	Remove the foreign object. Check for labels stuck on the side or bottom of parts.
2	Paper feed actuator L/R coming off or caught in sections of the machine	Reattach the paper feed actuator L/R.
3	Connection failure of the paper feed/paper printing position sensor PCB harness	Reconnect the paper feed/paper printing position sensor PCB harness.
4	Paper feed/paper printing position sensor PCB failure	Replace the paper feed/paper printing position sensor PCB ASSY.
5	Main PCB failure	Replace the main PCB ASSY.

■ Paper is jammed in the paper eject path

<User Check>

- Rotate the paper 180 degrees in the paper tray.
- Check that the thickness of the paper is within the standard.
- Check that there is no label stuck in the paper feed path.

Step	Cause	Remedy
1	Top cover is not closed	Close the top cover.
2	Foreign object in the rear of the machine	Remove the foreign object. Check for labels stuck on the side or bottom of parts.
3	Eject actuator caught in sections of the machine	Reattach the eject actuator.
4	Connection failure of the eject sensor PCB harness	Reconnect the eject sensor PCB harness.
5	Eject sensor failure	Replace the eject sensor PCB ASSY.
6	Connection failure of the paper feed/paper printing position sensor PCB harness	Reconnect the paper feed/paper printing position sensor PCB harness.
7	Paper feed/paper printing position sensor PCB failure	Replace the paper feed/paper printing position sensor PCB ASSY.
8	Develop joint link failure	Replace the develop joint link.
9	Fuser unit failure	Replace the fuser unit.
10	Main PCB failure	Replace the main PCB ASSY.

4.2 Troubleshooting According to Image Defect

End users can solve problems related to image defects as long as they follow the User Check items. If the problem still cannot be solved, implement each procedure according to the step numbers in the tables below.

4.2.1 Light

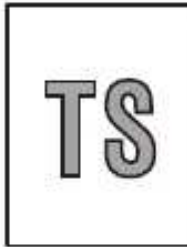

<User Check>

- Check the usage environment of the machine. Using the machine in hot-humid or cold-dry conditions can cause this problem.
- If the whole page is light, toner save mode may be ON. Turn OFF the toner save mode.
- Adjust the density using the Density Adjustment.
- Replace the drum unit with a new one.
- Replace the toner cartridge with a new one.

Step	Cause	Remedy
1	Dirt on electrodes of the drum unit and those of the machine	Clean the electrodes of the drum unit and those of the machine. (Refer to Fig. 1-6 or Fig. 1-7.)
2	Toner type determination failure when a new toner cartridge is detected	Reset the toner manually. (Refer to "6. RESETTING TONER MANUALLY" in Chapter 4.)
3	Fuser unit failure	Replace the fuser unit.
4	High voltage power supply PCB failure	Replace the high voltage power supply PCB ASSY.
5	Laser unit failure	Replace the laser unit.
6	Main PCB failure	Replace the main PCB ASSY.

■ Electrodes location of the toner cartridge and drum unit

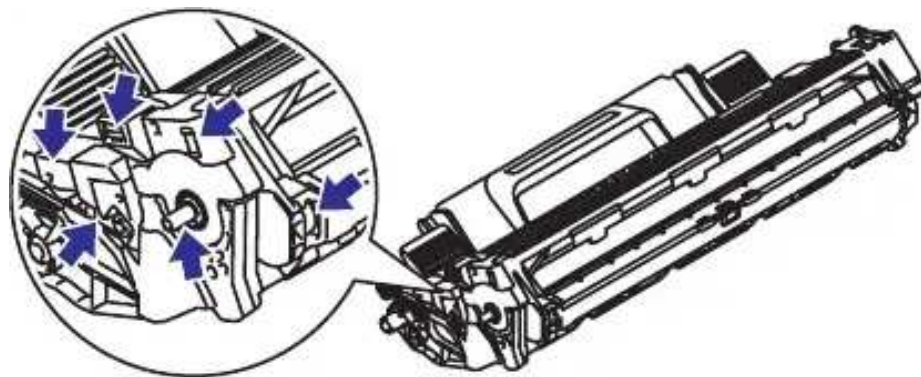

Fig. 1-6

■ Electrodes location of the machine

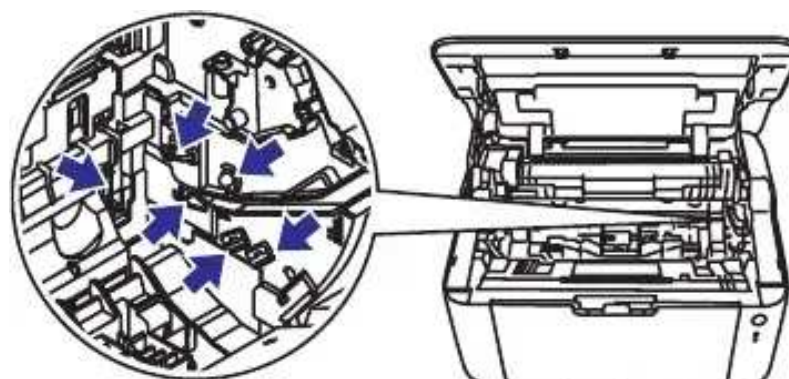

Fig. 1-7

4.2.2 Faulty registration



<User Check>

- Check that the appropriate paper type is selected in the driver.

Step	Cause	Remedy
1	Adjusted value of the laser unit is incorrect.	Refer to “2.1 Entering Adjusted Value of Laser Unit” in Chapter 3, and enter the adjusted value of the laser unit again.
2	Paper printing position actuator caught in sections of the machine	Reattach the paper printing position actuator.
3	Laser unit failure	Replace the laser unit.

4.2.3 Dark



<User Check>

- Check the usage environment of the machine. Using the machine in hot-humid or cold-dry conditions can cause this problem.
- Clean the corona wire of the drum unit.
- If a new toner cartridge has been set, check that it was not replaced with a used toner cartridge.
- Replace the drum unit with a new one.
- Replace the toner cartridge with a new one.

Step	Cause	Remedy
1	Dirt on electrodes of the drum unit and those of the machine	Clean the electrodes of the drum unit and those of the machine. (Refer to Fig. 1-6 or Fig. 1-7.)
2	High voltage power supply PCB failure	Replace the high voltage power supply PCB ASSY.
3	Laser unit failure	Replace the laser unit.
4	Main PCB failure	Replace the main PCB ASSY.

4.2.4 Poor fixing

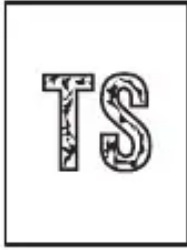

<User Check>

- Check the usage environment of the machine. Using the machine in hot-humid or cold-dry conditions can cause this problem.
- Clean the corona wire of the drum unit.
- Replace the drum unit with a new one.
- Replace the toner cartridge with a new one.

Step	Cause	Remedy
1	Fuser unit failure	Replace the fuser unit.
2	High voltage power supply PCB failure	Replace the high voltage power supply PCB ASSY.
3	Laser unit failure	Replace the laser unit.
4	Main PCB failure	Replace the main PCB ASSY.
5	Low voltage power supply PCB failure	Replace the low voltage power supply PCB unit.

4.2.5 Completely blank



<User Check>

- Clean the corona wire of the drum unit.
- Replace the drum unit with a new one.
- Replace the toner cartridge with a new one.

Step	Cause	Remedy
1	Dirt on electrodes of the drum unit and those of the machine, and dirt on ground wire.	Clean the electrodes of the drum unit and those of the machine, and the grounding wire. (Refer to Fig. 1-6 or Fig. 1-7.)
2	Laser unit attachment failure	Reattach the laser unit.
3	Connection failure of the laser unit flat cable	Reconnect the laser unit flat cable.
4	Connection failure of the high voltage PCB flat cable	Reconnect the high voltage PCB flat cable.
5	Disconnection of the laser unit flat cable	Replace the laser unit flat cable.
6	Laser unit failure	Replace the laser unit.
7	High voltage power supply PCB failure	Replace the high voltage power supply PCB ASSY.
8	Main PCB failure	Replace the main PCB ASSY.

4.2.6 Image distortion

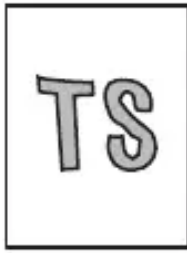

Step	Cause	Remedy
1	Laser unit attachment failure	Reattach the laser unit, and firmly tighten the screws.
2	Dirt on high-voltage electrodes and electrodes of the machine	Clean the high-voltage electrodes and electrodes of the machine.
3	Laser unit FG plate attachment failure (not grounded correctly)	Retighten the screws to secure the laser unit FG plate.
4	Laser unit failure	Replace the laser unit.
5	Main PCB failure	Replace the main PCB ASSY.

4.2.7 All black



<User Check>

- Clean the corona wire of the drum unit.
- Replace the drum unit with a new one.

Step	Cause	Remedy
1	Dirt on electrodes of the drum unit and those of the machine	Clean the electrodes of the drum unit and those of the machine. (Refer to Fig. 1-6 or Fig. 1-7.)
2	Connection failure of the laser unit flat cable	Reconnect the laser unit flat cable.
3	Laser unit FG plate attachment failure (not grounded correctly)	Check the contact of the laser unit FG plate, and retighten the screws.
4	High voltage power supply PCB failure	Replace the high voltage power supply PCB ASSY.
5	Laser unit failure	Replace the laser unit.
6	Main PCB failure	Replace the main PCB ASSY.

4.2.8 Dirt on the back of paper

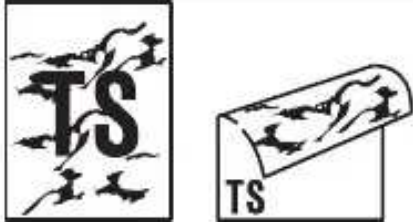

<User Check>

- This problem may disappear after printing multiple sheets of paper.
- Replace the toner cartridge with a new one.

Step	Cause	Remedy
1	Dirt on paper feed system	Wipe off the dirt.
2	Dirt on the fuser unit	Replace the fuser unit.

4.2.9 Vertical streaks

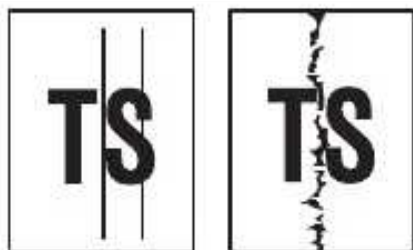

<User Check>

- Clean the inside of the machine and the corona wire of the drum unit.
- Return the corona wire cleaning tab to the “▲” position.
- This problem may disappear after printing multiple sheets of paper.
- Replace the drum unit with a new one.
- Replace the toner cartridge with a new one.

Step	Cause	Remedy
1	Attachment failure of the FG harness or FG plate (not grounded correctly)	Retighten the screws to secure the FG harness or FG plate.
2	Scratch or dirt on the heat unit	Replace the fuser unit.

Note:

- If the machine prints the same pattern continuously, especially a pattern including vertical streaks, black vertical streaks may appear on the paper because the electrostatic performance of the exposure drum has lowered temporarily.

4.2.10 Black vertical streaks on a light background



<User Check>

- Clean the inside of the machine and the corona wire of the drum unit.
- Replace the drum unit with a new one.
- Replace the toner cartridge with a new one.

Step	Cause	Remedy
1	Dirt on paper feed system	Wipe off the dirt.
2	Scratch or dirt on the heat unit	Replace the fuser unit.
3	Foreign object in the laser unit	Replace the laser unit.

4.2.11 Black horizontal stripes



<User Check>

- Clean the inside of the machine and the corona wire of the drum unit.
- This problem may disappear after printing multiple sheets of paper.
- Replace the toner cartridge with a new one.
- Replace the drum unit with a new one.

Step	Cause	Remedy
1	Dirt on electrodes of the drum unit and those of the machine	Clean the electrodes of the drum unit and those of the machine. (Refer to Fig. 1-6 or Fig. 1-7.)
2	Dirt on electrodes of the toner cartridge and those of the machine	Clean the electrodes of the toner cartridge and those of the machine. (Refer to Fig. 1-6 or Fig. 1-7.)
3	Attachment failure of the FG harness or FG plate (not grounded correctly)	Retighten the screws to secure the FG harness or FG plate.
4	Scratch or dirt on the heat unit	Replace the fuser unit.
5	High voltage power supply PCB failure	Replace the high voltage power supply PCB ASSY.
6	Main PCB failure	Replace the main PCB ASSY.

Image defects which appear periodically may be caused by failure of rollers. Refer to the table below and determine the responsible roller based on the pitch at which defects appear on the image.

Part name	Diameter	Pitch at which defects appear in the image
Developer roller	ø 13 mm	26.0 mm
Transfer roller	ø 13 mm	38.0 mm
Exposure drum	ø 24 mm	75.4 mm
Heat roller	ø 25 mm	78.5 mm
Pressure roller	ø 25 mm	78.5 mm

4.2.12 White vertical streaks



<User Check>

- Check that there is no dust in the gap between the toner cartridge and drum unit.
- Replace the toner cartridge with a new one.
- Check the usage environment of the machine. Using the machine in hot-humid or cold-dry conditions can cause this problem.
- Check that the paper is not damp.
- Leave the machine for a while before printing again.
- Replace the drum unit with a new one.

Step	Cause	Remedy
1	Laser unit failure	Replace the laser unit.

4.2.13 White horizontal streaks



<User Check>

- This problem may disappear after printing multiple sheets of paper. When the machine has not been used for long periods of time, try printing several sheets of paper.
- Replace the drum unit with a new one.
- Replace the toner cartridge with a new one.

Step	Cause	Remedy
1	Dirt on electrodes of the drum unit and those of the machine	Clean the electrodes of the drum unit and those of the machine. (Refer to Fig. 1-6 or Fig. 1-7.)
2	Dirt on electrodes of the toner cartridge and those of the machine	Clean the electrodes of the toner cartridge and those of the machine. (Refer to Fig. 1-6 or Fig. 1-7.)
3	High voltage power supply PCB failure	Replace the high voltage power supply PCB ASSY.

4.2.14 Faint print



<User Check>

- Check that the machine is positioned on a level surface.
- Replace the toner cartridge with a new one.
- Replace the drum unit with a new one.

Step	Cause	Remedy
1	Fuser unit failure	Replace the fuser unit.
2	Laser unit failure	Replace the laser unit.
3	Main PCB failure	Replace the main PCB ASSY.

4.2.15 White spots



<User Check>

- Turn ON the power switch, then open the top cover. Leave the machine for a while to remove condensation.
- Replace the toner cartridge with a new one.
- Replace the drum unit with a new one.

Step	Cause	Remedy
1	Dirt on electrodes of the drum unit and those of the machine	Clean the electrodes of the drum unit and those of the machine. (Refer to Fig. 1-6 or Fig. 1-7.)
2	Dirt on electrodes of the toner cartridge and those of the machine	Clean the electrodes of the toner cartridge and those of the machine. (Refer to Fig. 1-6 or Fig. 1-7.)
3	High voltage power supply PCB failure	Replace the high voltage power supply PCB ASSY.
4	Main PCB failure	Replace the main PCB ASSY.

4.2.16 Black spots

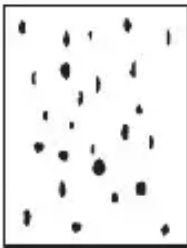

<User Check>

- This problem may disappear after printing multiple sheets of paper. When the machine has not been used for long periods of time, try printing several sheets of paper.
- Replace the toner cartridge with a new one.
- Replace the drum unit with a new one.

Step	Cause	Remedy
1	Dirt on electrodes of the drum unit and those of the machine	Clean the electrodes of the drum unit and those of the machine. (Refer to Fig. 1-6 or Fig. 1-7.)
2	Dirt on electrodes of the toner cartridge and those of the machine	Clean the electrodes of the toner cartridge and those of the machine. (Refer to Fig. 1-6 or Fig. 1-7.)
3	Scratch or dirt on the heat unit, or dirt on the pressure roller	Replace the fuser unit.
4	High voltage power supply PCB failure	Replace the high voltage power supply PCB ASSY.
5	Main PCB failure	Replace the main PCB ASSY.

4.2.17 Black band



<User Check>

- This problem may disappear after printing multiple sheets of paper. When the machine has not been used for long periods of time, try printing several sheets of paper.
- Replace the toner cartridge with a new one.
- Replace the drum unit with a new one.

Step	Cause	Remedy
1	Dirt on electrodes of the drum unit and those of the machine	Clean the electrodes of the drum unit and those of the machine. (Refer to Fig. 1-6 or Fig. 1-7.)
2	Dirt on electrodes of the toner cartridge and those of the machine	Clean the electrodes of the toner cartridge and those of the machine. (Refer to Fig. 1-6 or Fig. 1-7.)
3	Scratch or dirt on the heat unit or, dirt on the pressure roller	Replace the fuser unit.
4	Main PCB failure	Replace the main PCB ASSY.

4.2.18 Downward fogging of solid color



<User Check>

- Replace the toner cartridge with a new one.
- Replace the drum unit with a new one.

Step	Cause	Remedy
1	High voltage power supply PCB failure	Replace the high voltage power supply PCB ASSY.
2	Main PCB failure	Replace the main PCB ASSY.

4.2.19 Horizontal lines



<User Check>

- Replace the toner cartridge with a new one.
- Replace the drum unit with a new one.

Step	Cause	Remedy
1	Fuser unit failure	Replace the fuser unit.
2	Laser unit failure	Replace the laser unit.

4.2.20 Ghost

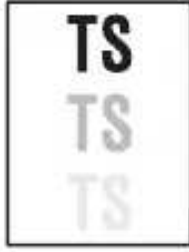

<User Check>

- Check the usage environment of the machine. Using the machine in hot-humid or cold-dry conditions can cause this problem.
- Check that the appropriate paper type is selected in the driver.
- Replace the drum unit with a new one.
- Turn the “Improve Toner Fixing” setting of the “Improve Print Output” ON in the driver.

Step	Cause	Remedy
1	High voltage power supply PCB failure	Replace the high voltage power supply PCB ASSY.
2	Main PCB failure	Replace the main PCB ASSY.

4.2.21 Fogging



<User Check>

- Check the usage environment of the machine. Using the machine in hot-humid or cold-dry conditions can cause this problem.
- This problem may disappear after printing multiple sheets of paper.
- Replace the drum unit with a new one.
- Replace the toner cartridge with a new one.
- Do not use acid paper.

Step	Cause	Remedy
1	High voltage power supply PCB failure	Replace the high voltage power supply PCB ASSY.
2	Main PCB failure	Replace the main PCB ASSY.

Note:

- This problem tends to occur when the life of the drum unit or toner cartridge is expiring.

4.3 Troubleshooting for Software Problems

End users can solve problems related to software, for instance, printing is not possible from a computer although test print or Printer Settings print can be performed from the machine, as long as they follow the User Check items. If the problem still cannot be solved, implement each procedure according to the step numbers in the tables below.

4.3.1 Cannot print data

<User Check>

- Check that the USB cable is not damaged.
- When using an interface switch, check that the correct machine is selected.
- Check the relevant section in the User's Guide.
- Check the driver settings.
- Reset the machine to the default settings. (Refer to the User's Guide.)

Step	Cause	Remedy
1	Machine connection	For Macintosh, check the Product ID*. When it is wrong, update the firmware.
2	Main PCB failure	Replace the main PCB ASSY.

* Check the Product ID on a Macintosh according to the following procedure:

- (1) Select "About This Mac" from the "Apple" menu.
- (2) Press the "More Info..." button in the "About This Mac" dialog box.
- (3) Select "USB" at the bottom of "Hardware" in the "Content" on the left side of the screen.
- (4) Select "HL-XXXX" in the "USB Device Tree".
- (5) Check the "Product ID" under "HL-XXXX".

Product ID (hexadecimal)

- HL-1110 : 0054h
- HL-1111 : 0054h
- HL-1112 : 0054h
- HL-1118 : 0054h

4.4 Troubleshooting for Toner and Drum Problems

4.4.1 Replaced the toner cartridge with a new one but still seeing LED display prompting toner cartridge replacement.

<User Check>

- Check that a new (not used) toner cartridge is set.

Step	Cause	Remedy
1	Connection failure of the motor encoder PCB flat cable	Reconnect the motor encoder PCB flat cable.
2	Connection failure of the new toner sensor PCB harness	Reconnect the new toner sensor PCB harness.
3	Motor encoder PCB failure	Replace the motor encoder PCB ASSY.
4	New toner sensor failure	Replace the new toner sensor PCB ASSY.
5	Main PCB failure	Replace the main PCB ASSY.

4.4.2 Toner cartridge cannot be detected

<User Check>

- Set the toner cartridge correctly.

Step	Cause	Remedy
1	Connection failure of the motor encoder PCB flat cable	Reconnect the motor encoder PCB flat cable.
2	Connection failure of the new toner sensor PCB harness	Reconnect the new toner sensor PCB harness.
3	Motor encoder PCB failure	Replace the motor encoder PCB ASSY.
4	New toner sensor failure	Replace the new toner sensor PCB ASSY.
5	Main PCB failure	Replace the main PCB ASSY.

4.4.3 Failed to detect toner cartridge

Step	Cause	Remedy
1	The power switch was turned OFF or the top cover was opened while a new toner cartridge was being detected.	Reset the toner manually. (Refer to "6. RESETTING TONER MANUALLY " in Chapter 4.)
2	Main PCB failure	Replace the main PCB ASSY.

4.4.4 Drum error

<User Check>

- Clean the corona wire of the drum unit.
- Replace the drum unit with a new one, and reset the drum counter.

Step	Cause	Remedy
1	Dirt on electrodes of the drum unit and those of the machine	Clean the electrodes of the drum unit and those of the machine. (Refer to Fig. 1-6 or Fig. 1-7.)
2	Connection failure of the high voltage PCB harness	Reconnect the high voltage PCB harness.
3	High voltage power supply PCB failure	Replace the high voltage power supply PCB ASSY.
4	Main PCB failure	Replace the main PCB ASSY.

4.4.5 Drum unit cannot be detected.

<User Check>

- Set the drum unit correctly.

Step	Cause	Remedy
1	Dirt on electrodes of the drum unit and those of the machine	Clean the electrodes of the drum unit and those of the machine. (Refer to Fig. 1-6 or Fig. 1-7.)
2	Connection failure of the high voltage PCB harness	Reconnect the high voltage PCB harness.
3	High voltage power supply PCB failure	Replace the high voltage power supply PCB ASSY.
4	Main PCB failure	Replace the main PCB ASSY.

4.4.6 Replace drum unit (replaced the drum unit with a new one but still seeing LED display prompting toner cartridge replacement)

<User Check>

- Replace the drum unit with a new one, and reset the drum counter.

Step	Cause	Remedy
1	Main PCB failure	Replace the main PCB ASSY.

4.5 Troubleshooting for Fuser Unit Problems





4.5.1 Fuser unit failure

Step	Cause	Remedy
1	Connection failure of the center thermistor harness of the fuser unit	Reconnect the center thermistor harness of the fuser unit.
2	Connection failure of the low voltage PCB harness	Reconnect the low voltage PCB harness.
3	Connection failure of the heater harness of the fuser unit	Reconnect the heater harness of the fuser unit.
4	Low voltage power supply PCB failure	Replace the low voltage power supply PCB unit.
5	Fuser unit failure	Replace the fuser unit.
6	Main PCB failure	Replace the main PCB ASSY.

Note:

- Turn the power switch OFF and then back ON again. Leave the machine for approximately 15 minutes to cool the heater. This problem may have then been solved.
- Errors of the fuser unit can be reset by the following operation. However, note that if this operation is performed while the heater has not cooled down, the fuser unit may melt.

<Operating Procedure>

- (1) Check that the power switch is turned OFF. Press and hold the  button and check that the Ready and Error LEDs are lit. Then open the top cover and check that the Error LED goes out and only the Ready LED is lit.
- (2) Take out the drum unit and check that the Error LED is lit. Check that the Ready and Error LEDs are lit and release the  button. Check that all LEDs go out.
- (3) Set the drum unit and close the top cover.
- (4) Press the  button once. Check that the Error LED is lit.
- (5) Press the  button once to start the maintenance printing.

4.6 Troubleshooting for Laser Unit Problems

4.6.1 Laser unit failure

<User Check>

- Turn ON the power switch, then open the top cover. Leave the machine for a while to remove condensation.

Step	Cause	Remedy
1	Connection failure of the laser unit flat cable	Reconnect the laser unit flat cable.
2	Connection failure of the polygon motor harness	Reconnect the polygon motor harness.
3	Laser unit failure	Replace the laser unit.
4	Main PCB failure	Replace the main PCB ASSY.

4.7 Troubleshooting for Other Problems

4.7.1 Machine does not turn ON or LED does not light

<User Check>

- Press and hold the  button and check if the machine turns ON.
- Plug the AC cord into a socket.

Step	Cause	Remedy
1	Connection failure of the high voltage PCB harness	Reconnect the high voltage PCB harness.
2	Connection failure of the low voltage PCB harness	Reconnect the low voltage PCB harness.
3	LED failure	Replace the high voltage power supply PCB ASSY.
4	Low voltage power supply PCB failure	Replace the low voltage power supply PCB unit.
5	Main PCB failure	Replace the main PCB ASSY.

4.7.2 Top cover is open

Open top cover was detected.

<User Check>

- Check that the top cover is closed.

Step	Cause	Remedy
1	Connection failure of the laser unit flat cable	Reconnect the laser unit flat cable.
2	Connection failure of the eject sensor PCB harness	Reconnect the eject sensor PCB harness.
3	Connection failure of the paper feed/paper printing position sensor PCB harness	Reconnect the paper feed/paper printing position sensor PCB harness.
4	Eject actuator caught in sections of the machine	Reattach the eject actuator.
5	The rib inside the top cover (which presses the eject actuator or laser shutter arm) is broken.	Replace the top cover ASSY.
6	Eject sensor failure	Replace the eject sensor PCB ASSY.
7	Paper feed/paper printing position sensor PCB failure	Replace the paper feed/paper printing position sensor PCB ASSY.
8	Faulty laser shutter arm of the laser unit	Replace the laser unit.
9	Main PCB failure	Replace the main PCB ASSY.

4.7.3 Unusual noise is coming from the machine

Step	Cause	Remedy
1	Possible cause differs depending on the location. Identify the location with the problem first.	When the location with the problem is identified, check if there is a foreign object around that location (replace the parts around the location if necessary).
2	Insufficient grease on parts	Re-grease the parts.
3	Bent or defective part	Replace the part.

4.7.4 Memory failure

<User Check>

- Print the print data stored in the memory.
- Reduce the complexity or resolution of the data.
- Divide the data and print them separately.

Step	Cause	Remedy
1	Main PCB failure	Replace the main PCB ASSY.

4.7.5 Print failure

<User Check>

- Check that the maximum printable page number has not been exceeded.
- Turn the power switch OFF and then back ON again.

Step	Cause	Remedy
1	Main PCB failure	Replace the main PCB ASSY.

4.7.6 Paper size failure

<User Check>

- Set A4 or letter size paper in the paper tray.

Step	Cause	Remedy
1	Paper feed actuator L/R coming off	Reattach the paper feed actuator L/R.
2	Connection failure of the paper feed/paper printing position sensor PCB harness	Reconnect the paper feed/paper printing position sensor PCB harness.
3	Paper feed sensor failure	Replace the paper feed/paper printing position sensor PCB ASSY.
4	Main PCB failure	Replace the main PCB ASSY.

4.7.7 Main motor failure

Step	Cause	Remedy
1	Connection failure of the main motor harness	Reconnect the main motor harness.
2	Connection failure of the motor encoder PCB flat cable	Reconnect the motor encoder PCB flat cable.
3	Motor encoder PCB failure	Replace the motor encoder PCB ASSY.
4	Main PCB failure	Replace the main PCB ASSY.

4.7.8 Power supply voltage failure

Step	Cause	Remedy
1	Low voltage power supply PCB failure	Replace the low voltage power supply PCB unit. Refer to the "3. IF YOU REPLACE THE LOW VOLTAGE POWER SUPPLY PCB UNIT" in Chapter 3 to reset the irregular power supply detection counter.

4.7.9 High voltage power supply PCB failure

Step	Cause	Remedy
1	Connection failure of electrodes	Clean and reattach each electrode.
2	Connection failure of the high voltage PCB flat cable	Reconnect the high voltage PCB flat cable.
3	High voltage power supply PCB failure	Replace the high voltage power supply PCB ASSY.
4	Main PCB failure	Replace the main PCB ASSY.

4.7.10 Main PCB failure

<User Check>

- Turn the power switch OFF and then back ON again.

Step	Cause	Remedy
1	Firmware malfunction	Install the latest firmware.
2	Main PCB failure	Replace the main PCB ASSY.

CHAPTER 2 DISASSEMBLY/REASSEMBLY

Be sure to observe [Troubleshooting/Disassembling/Assembling Notes](#) during disassembly and assembly work.

1. PACKING

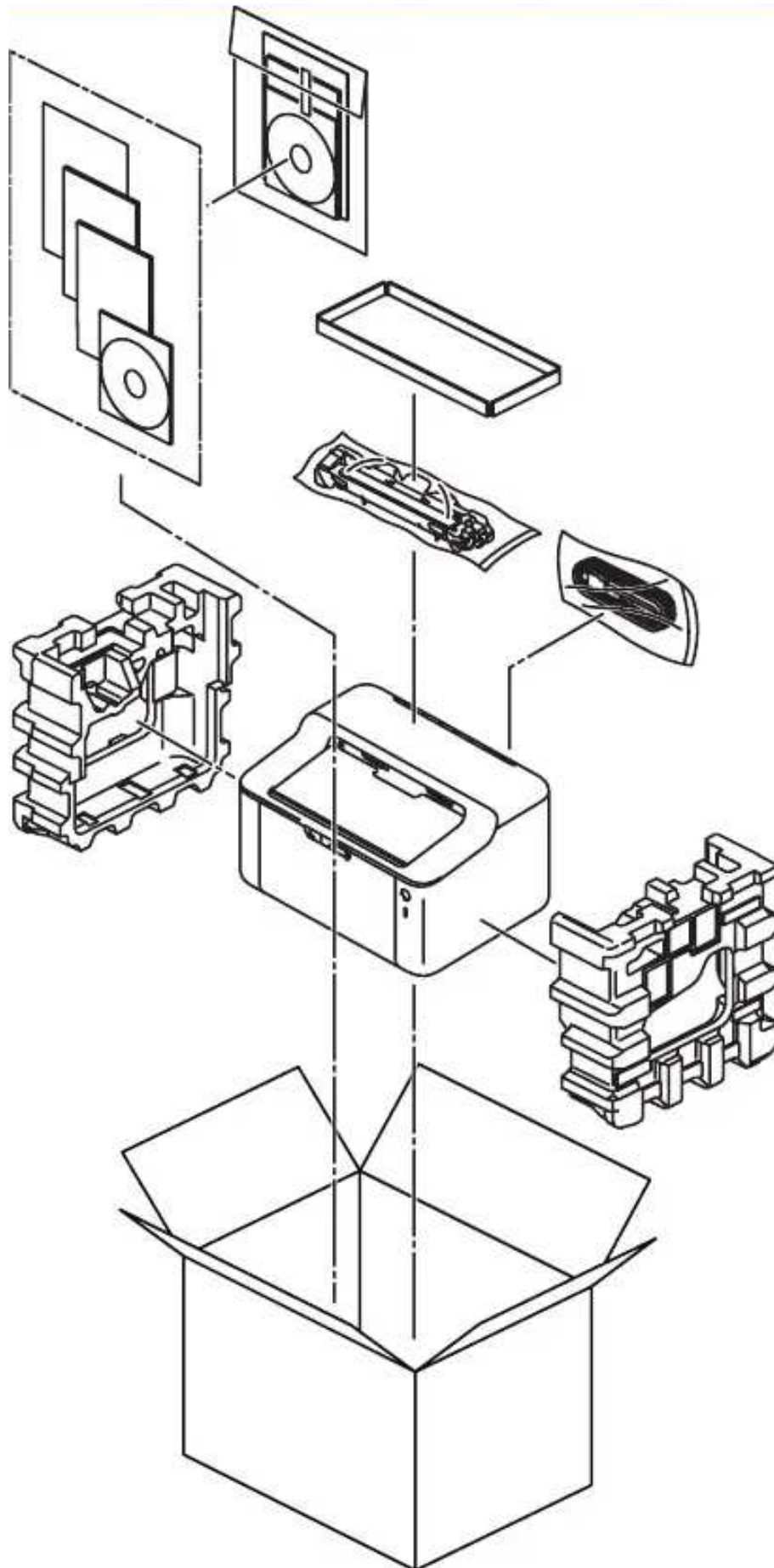

Fig. 2-1

2. TIGHTENING TORQUE LISTS

Location of screw	Part name	Q'ty	Tightening torque N·m (kgf·cm)
Back cover	Taptite bind B M4x12	2	0.8±0.1(8±1)
Low voltage shield plate cover	Taptite bind B M4x12	4	0.8±0.1(8±1)
	Taptite cup S M3x8 SR	2	0.6±0.1(6±1)
	Screw pan (S/P washer) M3.5x6	1	0.45±0.05(4.55±0.5)
Ground harness	Screw pan (S/P washer) M3.5x6	1	0.45±0.05(4.55±0.5)
Fuser unit	Taptite pan B M4x14	2	0.8±0.1(8±1)
Insulation roof	Taptite pan B M3x8	1	0.4±0.05(4±0.5)
High voltage power supply PCB ASSY	Taptite bind B M4x12	2	0.8±0.1(8±1)
Main PCB ASSY	Taptite cup S M3x6 SR	2	0.6±0.1(6±1)
		1	
Ground harness			
Front cover	Taptite bind B M4x12	4	0.8±0.1(8±1)
Laser unit	Taptite cup S M3x8 SR	3	0.8±0.1(8±1)
Paper feed/paper printing position sensor PCB ASSY	Taptite bind B M3x10	1	0.5±0.1(5±1)
Drive sub ASSY	Taptite bind B M4x12	4	0.8±0.1(8±1)

3. LUBRICATION

There are no parts that require lubrication.

4. OVERVIEW OF GEARS

■ Frame L

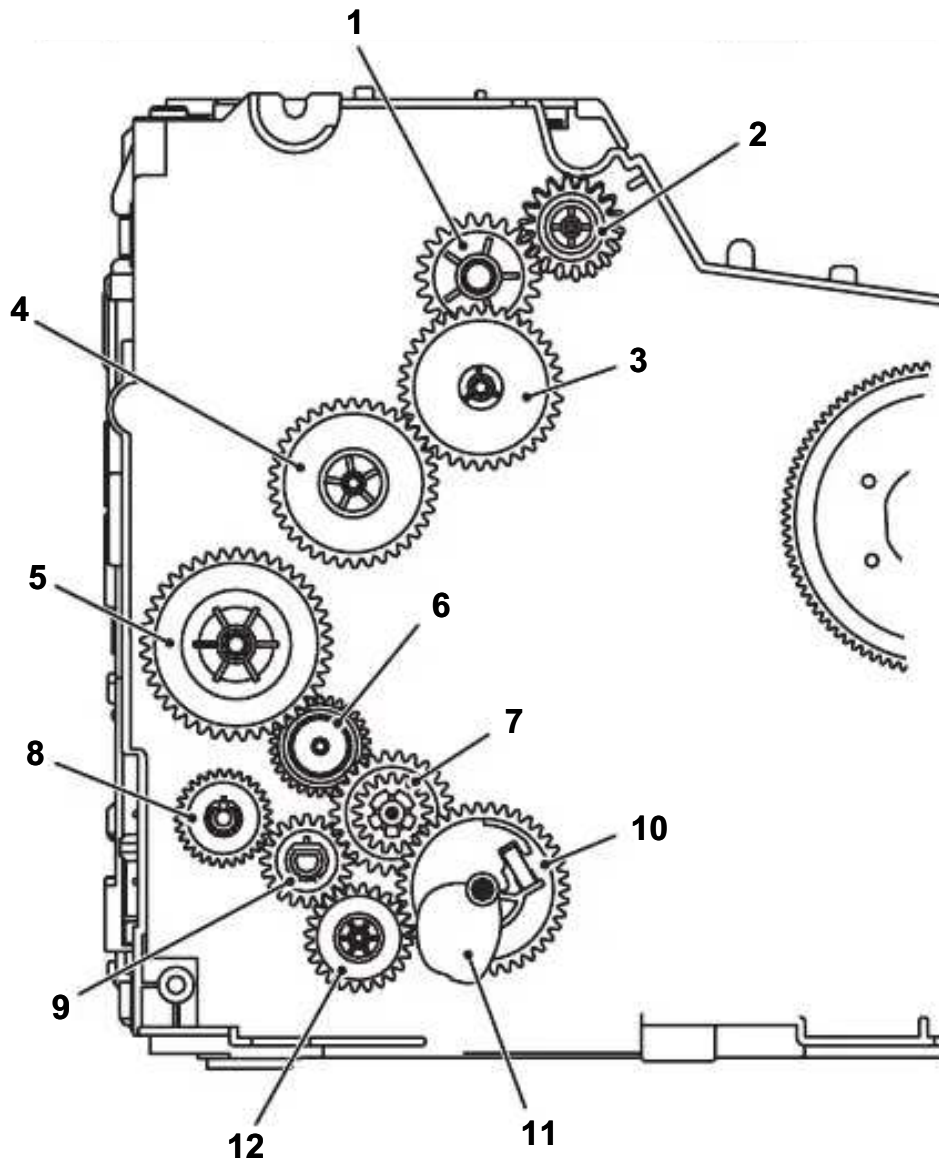
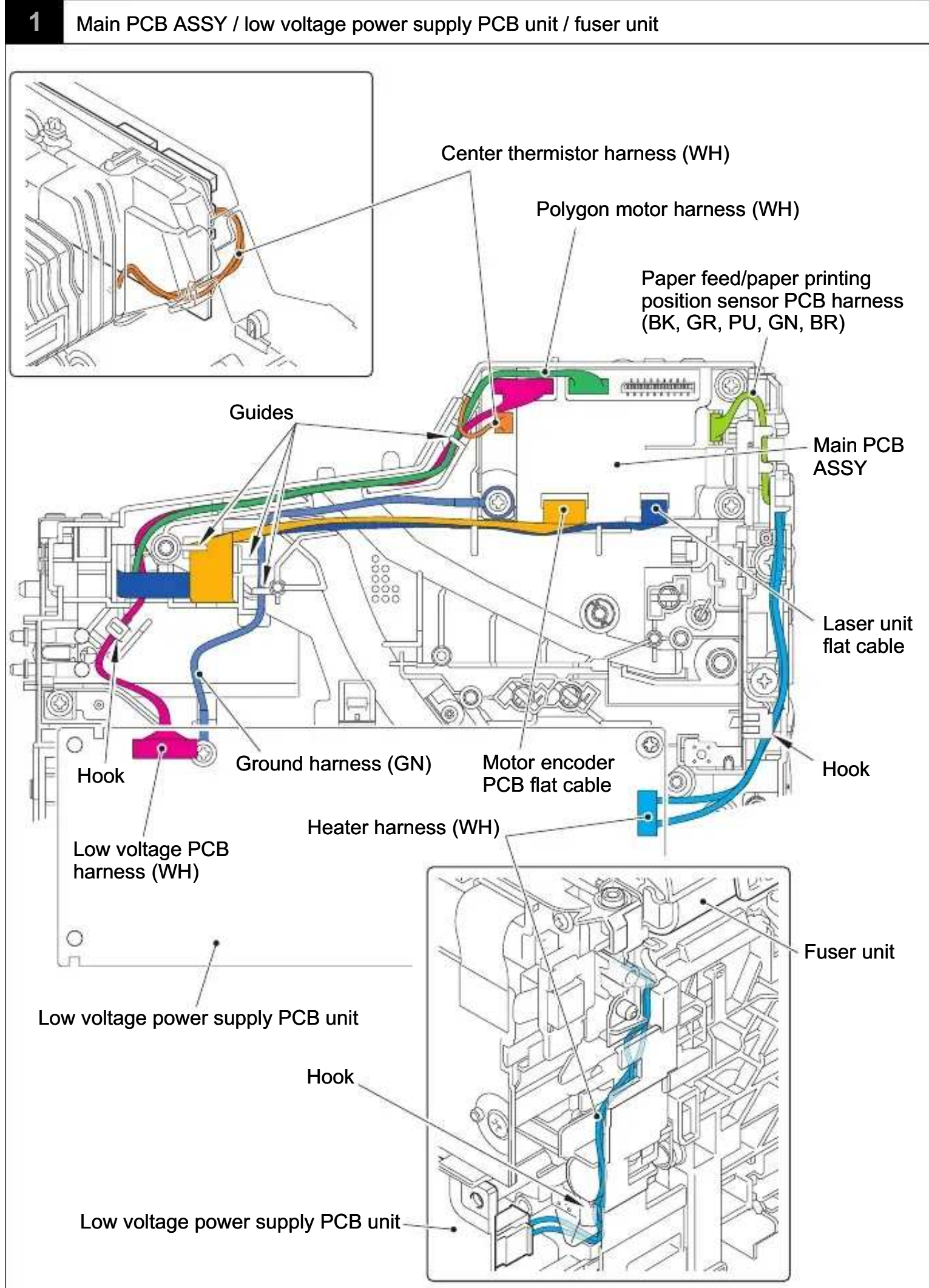

Fig. 2-2

<Name of gears>

1	LY8038	Fuser gear 22	7	LY8066	Feeder gear 17/32/26
2	LY8039	Ejector gear 17/18	8	LY8079	Feeder gear 29
3	LY8050	Fuser gear 20/35 pendulum	9	LY8080	T1 gear 20
4	LY8055	Fuser gear 36	10	LY8063	T1 gear sector
5	LY8067	Drum gear 18/41	11	LY8065	Plate down cam
6	LY8068	Feeder gear 30 pendulum	12	LY8062	T1 idle gear

5. HARNESS ROUTING



Harness colors are subject to change for some reason.

2 Laser unit / motor encoder PCB ASSY

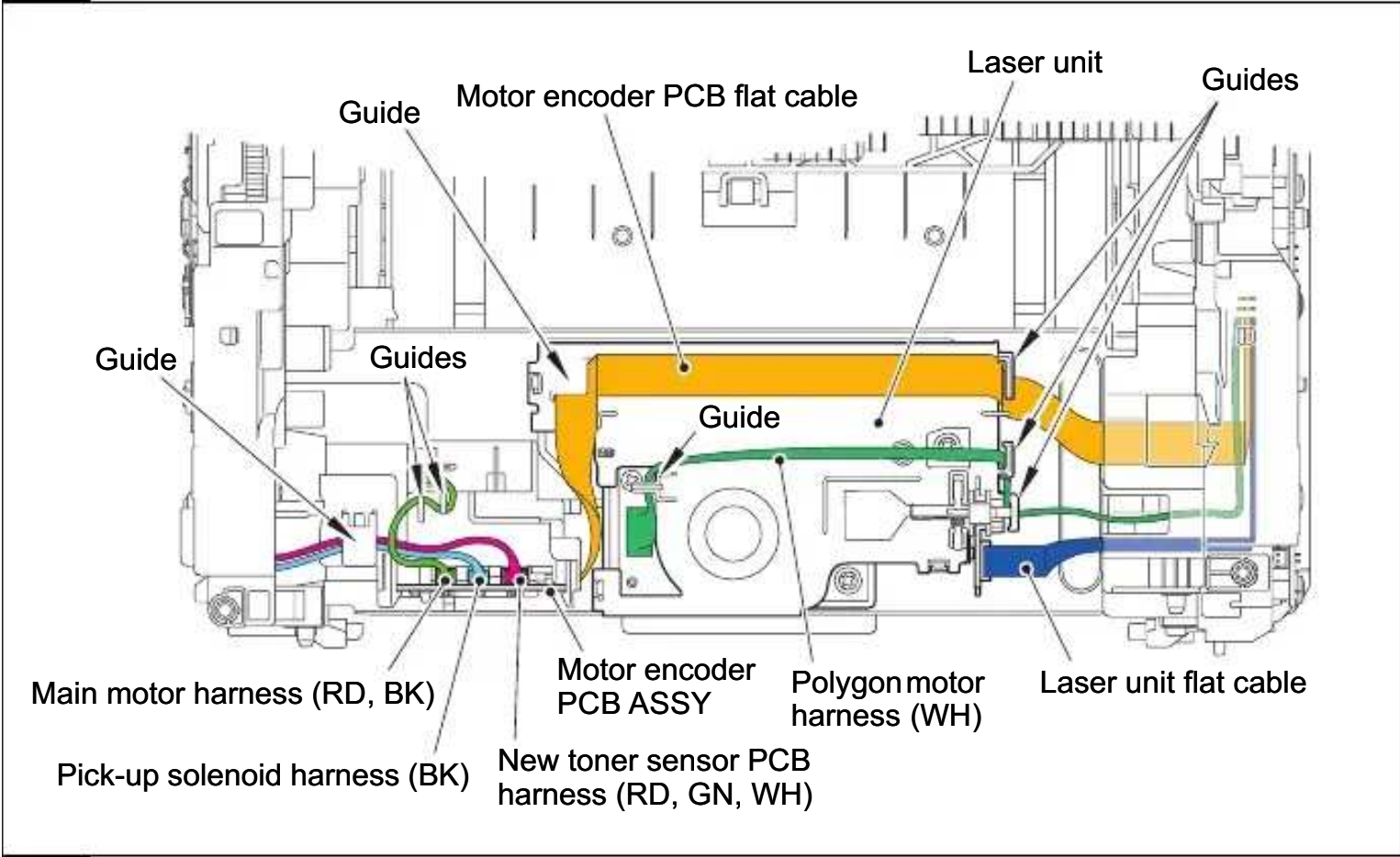

3 Eject sensor PCB ASSY

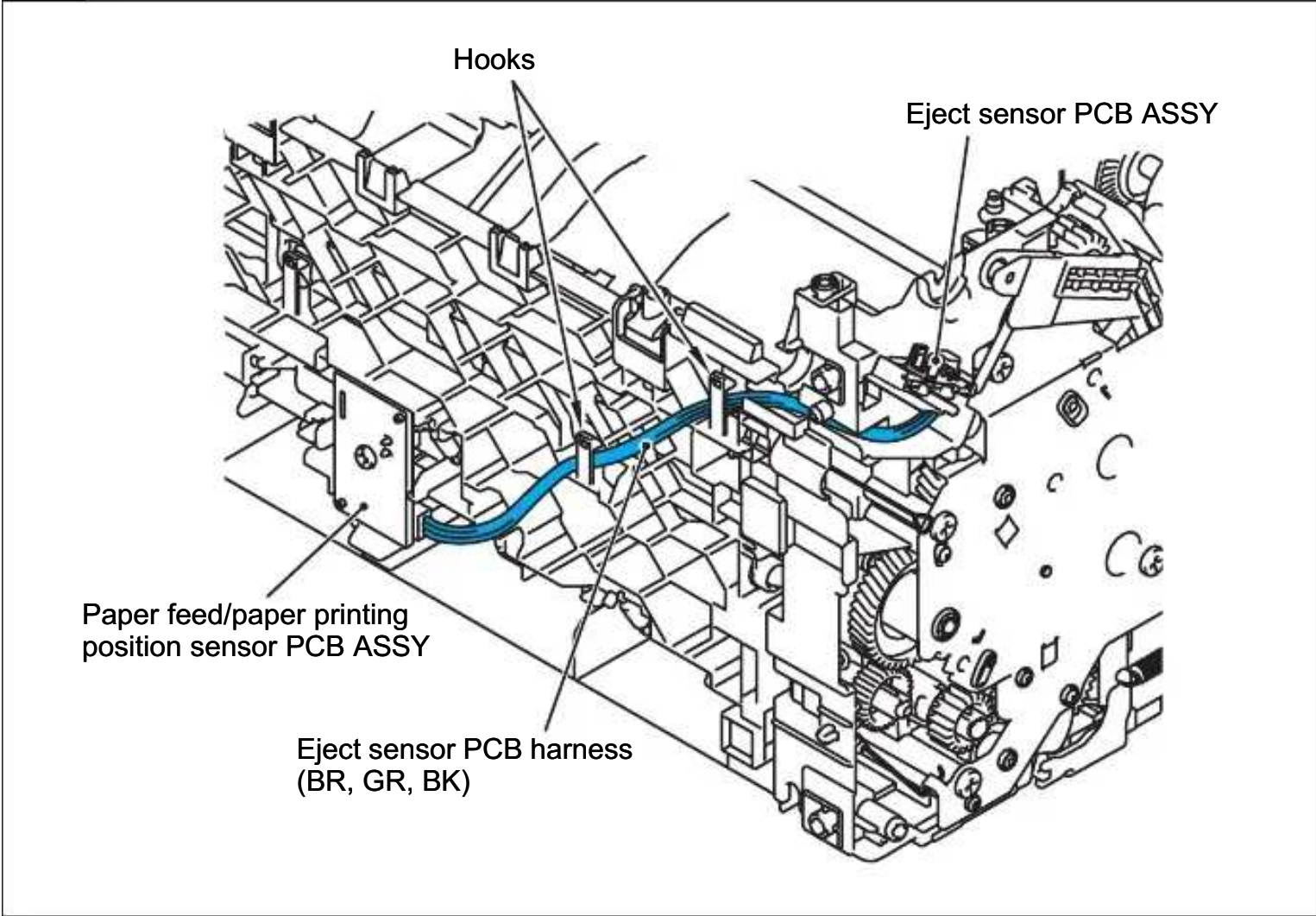

Harness colors are subject to change for some reason.

4 Paper feed/paper printing position sensor PCB ASSY

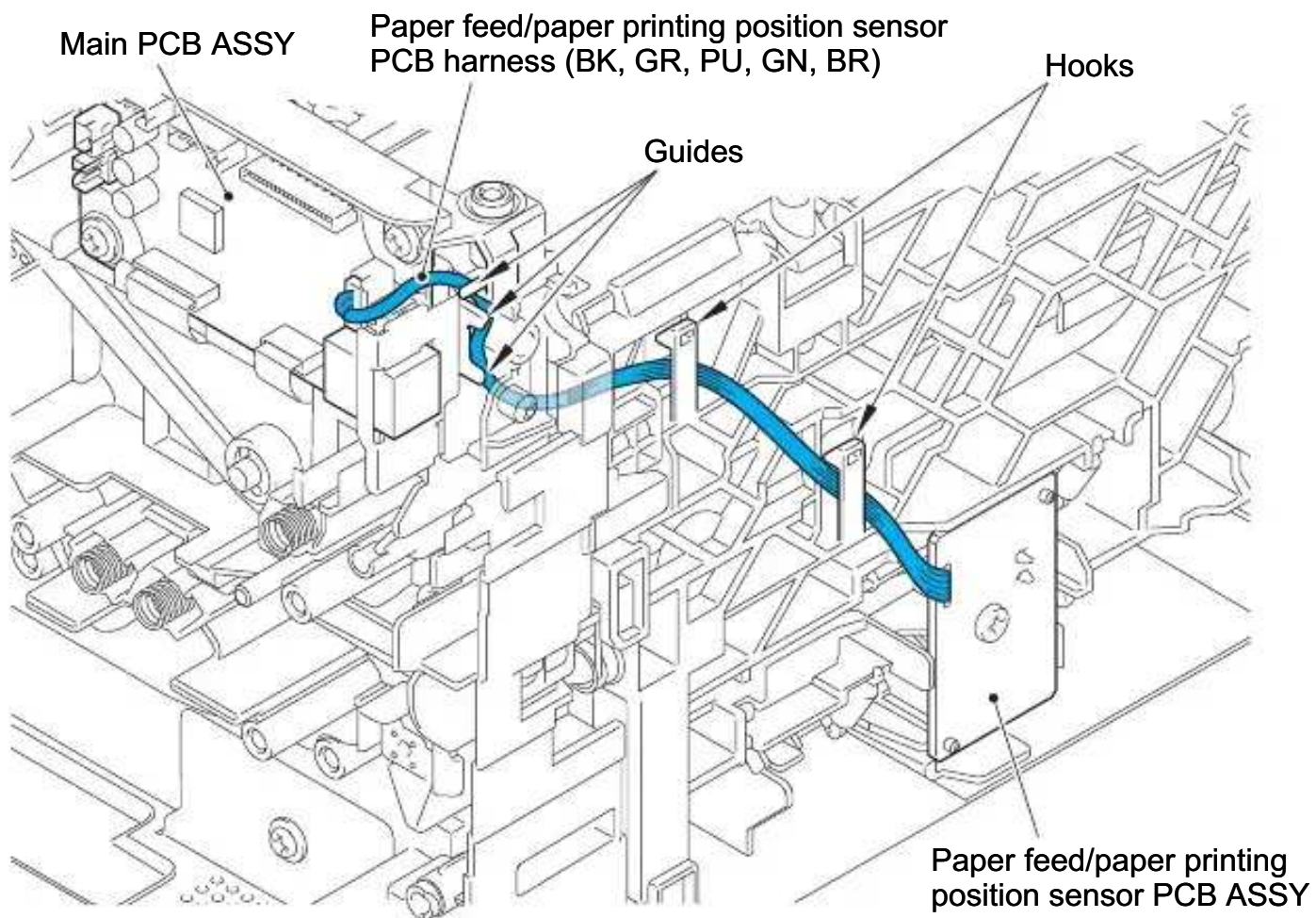

5 New toner sensor PCB ASSY / pick-up solenoid

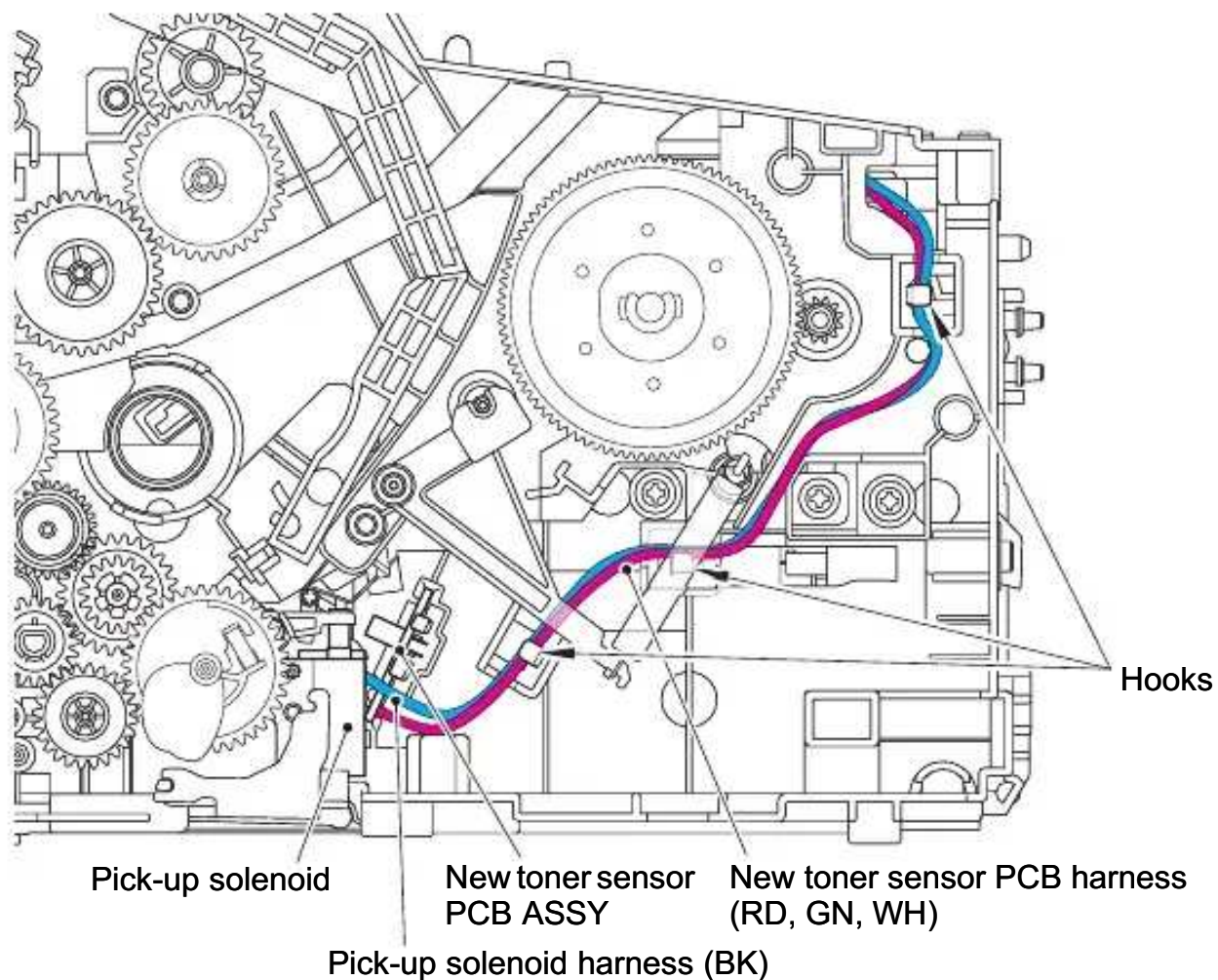

Harness colors are subject to change for some reason.

6. DISASSEMBLY FLOW CHART

Disassembly / Reassembly (second)

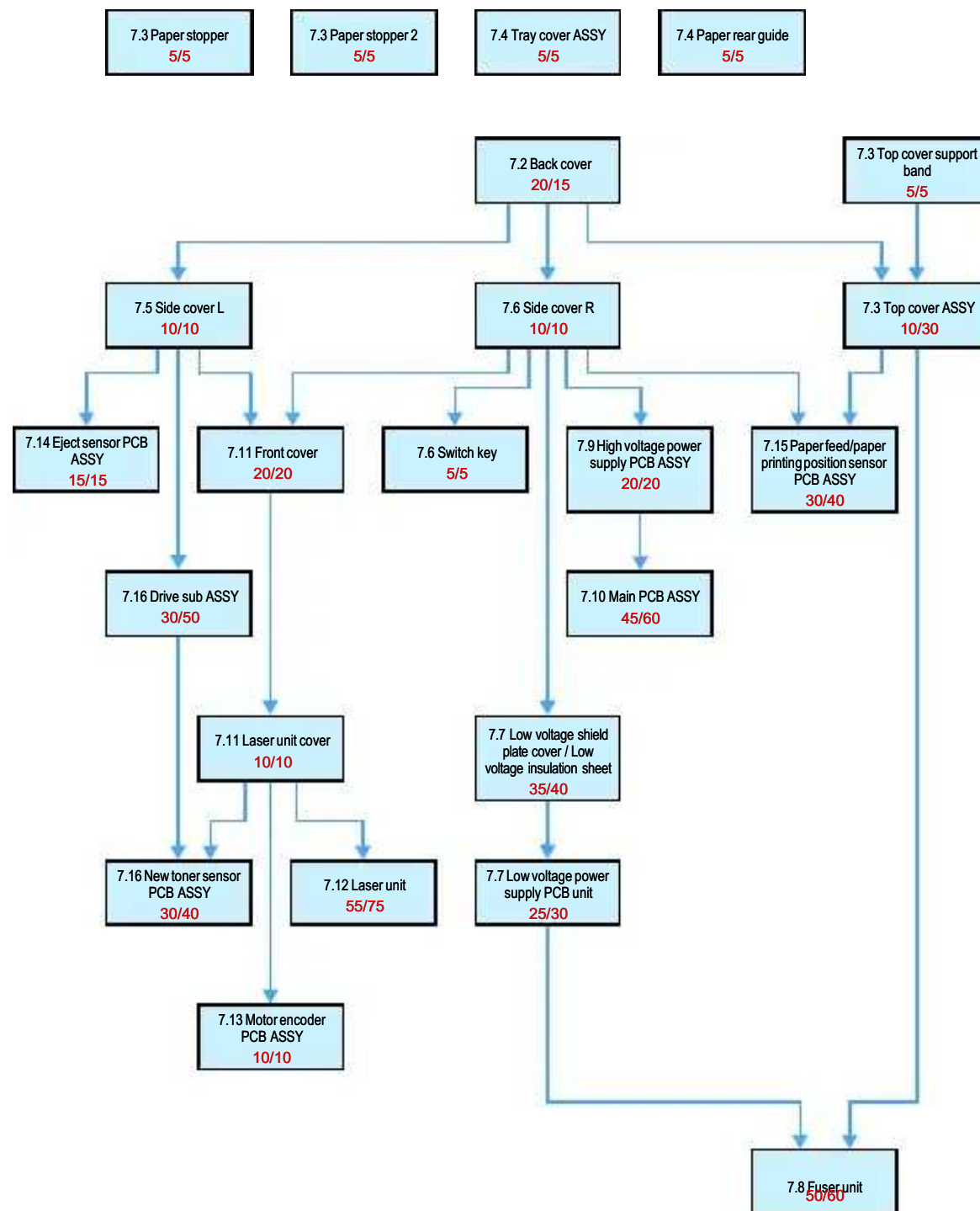

7. DISASSEMBLY PROCEDURE

7.1 Preparation

■ Disconnecting Cable and Removing Accessories

Prior to proceeding with the disassembly procedure,

- (1) Disconnect the following:
 - USB cable (if connected)
- (2) Remove the following:
 - Toner cartridge and drum unit

Toner cartridge
and drum unit

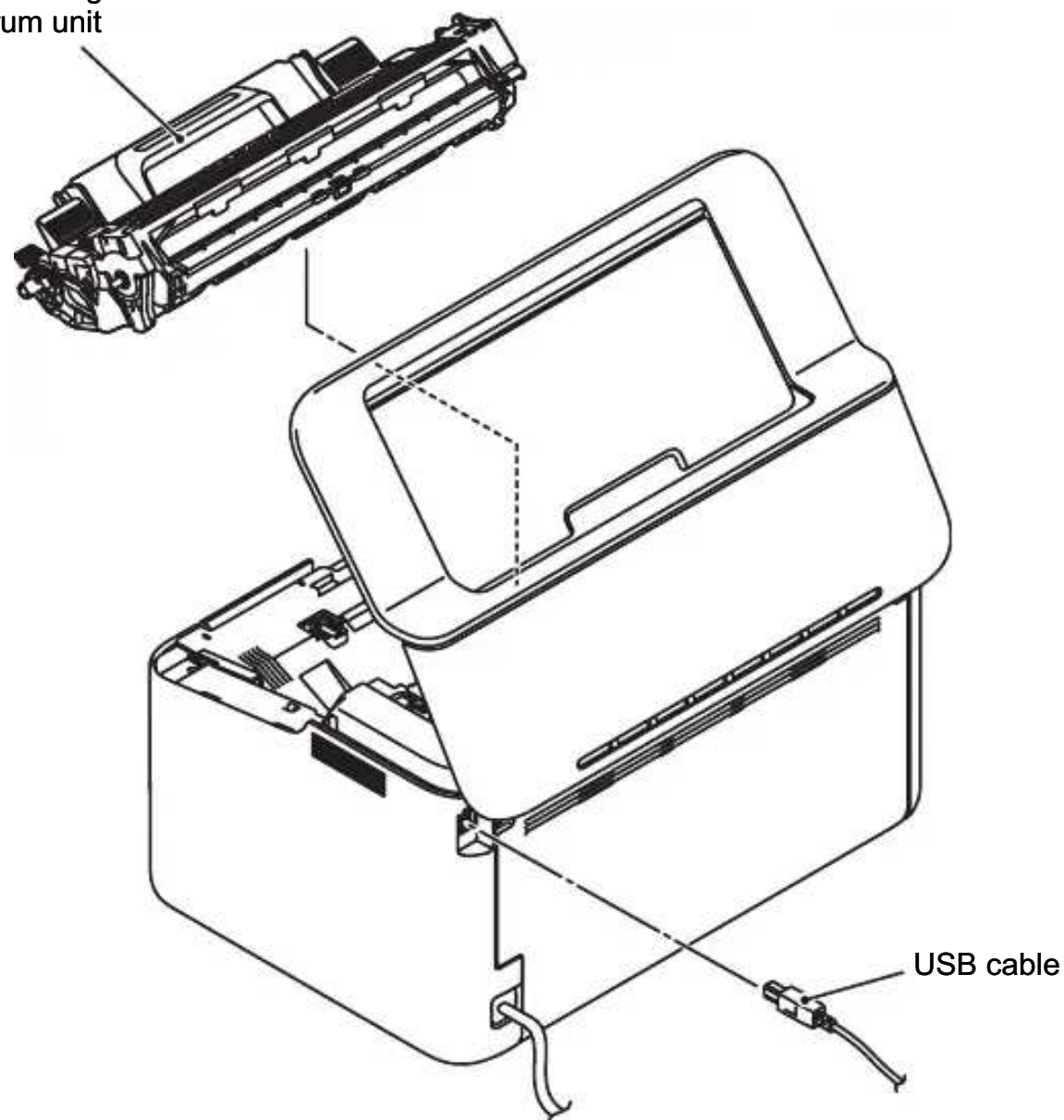

Fig. 2-3

7.2 Back cover

- (1) Remove the two taptite bind B M4x12 screws.
- (2) Release the two hooks at the top of the back cover while lifting it.
- (3) Slide the back cover downward to remove the two bosses at the bottom.

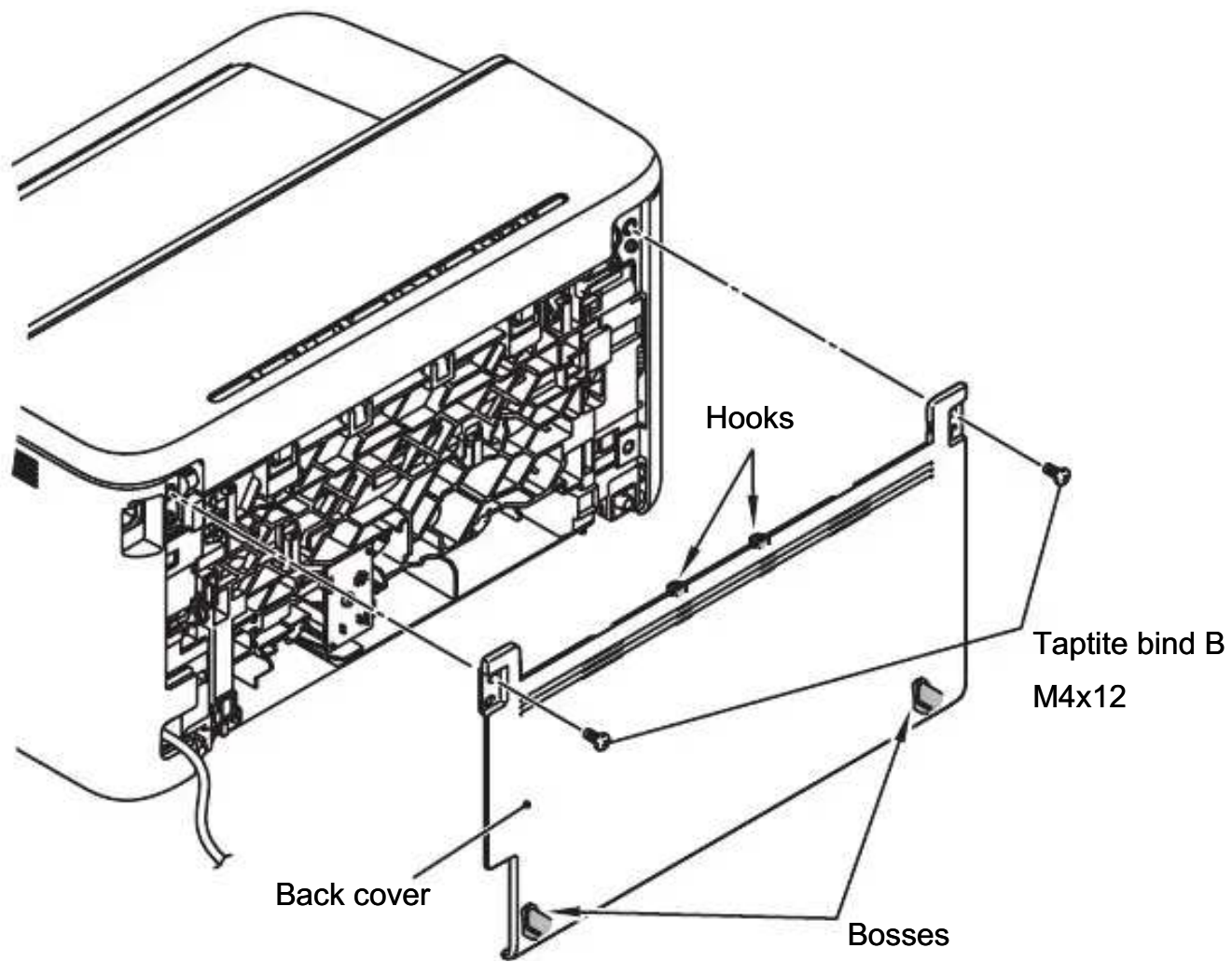

Fig. 2-4

7.3 Top cover ASSY

- (1) Open the top cover ASSY.
- (2) Bend the boss bushing of the develop joint link to the direction of the arrow 2 to remove it from the guide rail of the top cover ASSY.
- (3) Turn the top cover support band 90 degrees and slide it to the direction of the arrow 3 to remove it from the top cover ASSY.
- (4) Remove the top cover ASSY from the machine.

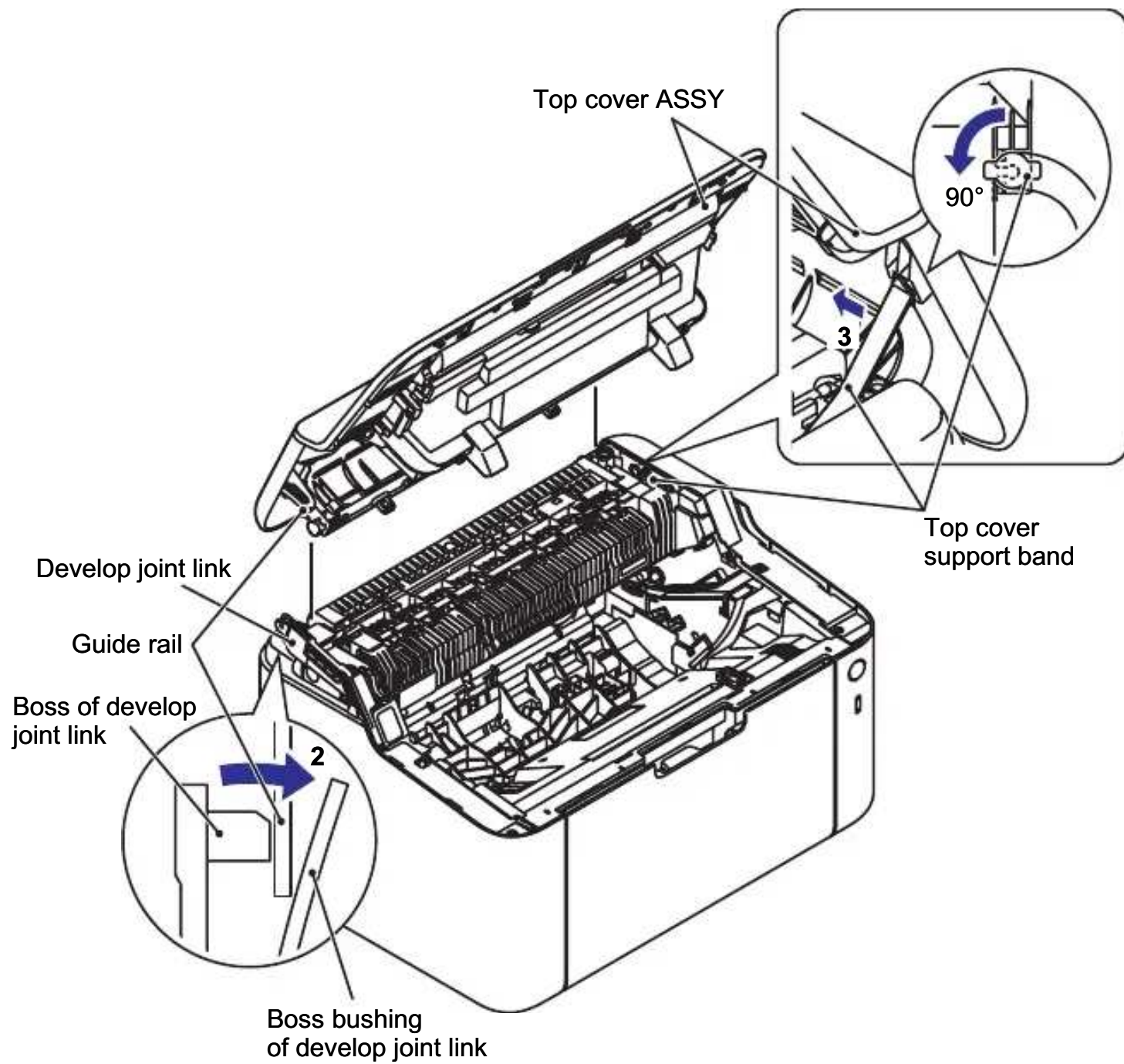

Fig. 2-5

- (5) Remove the two bosses of the paper stopper from the process cover ASSY.
- (6) Remove the two bosses of the paper stopper 2, and remove the paper stopper 2 from the paper stopper.

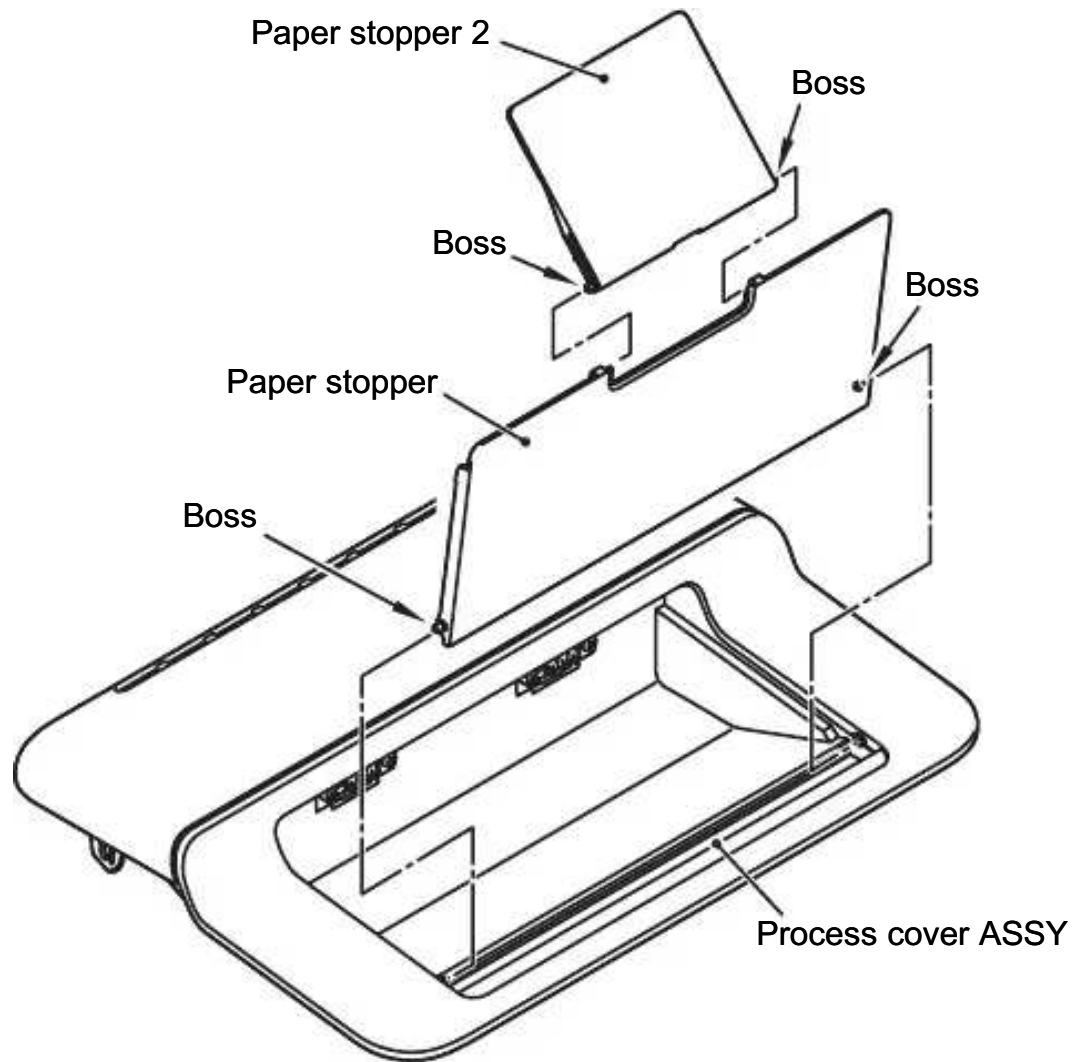

Fig. 2-6

- (7) Release the three hooks A of the top cover ASSY while sliding the dress cover to the direction of the arrow. Release the four tabs B of the dress cover and six tabs C of the top cover ASSY. Bend the three hooks D of the dress cover inward to remove the dress cover from the top cover ASSY.
- (8) Release the two hooks E of the process cover ASSY and four hooks F of the top cover ASSY to remove the process cover ASSY from the top cover ASSY.

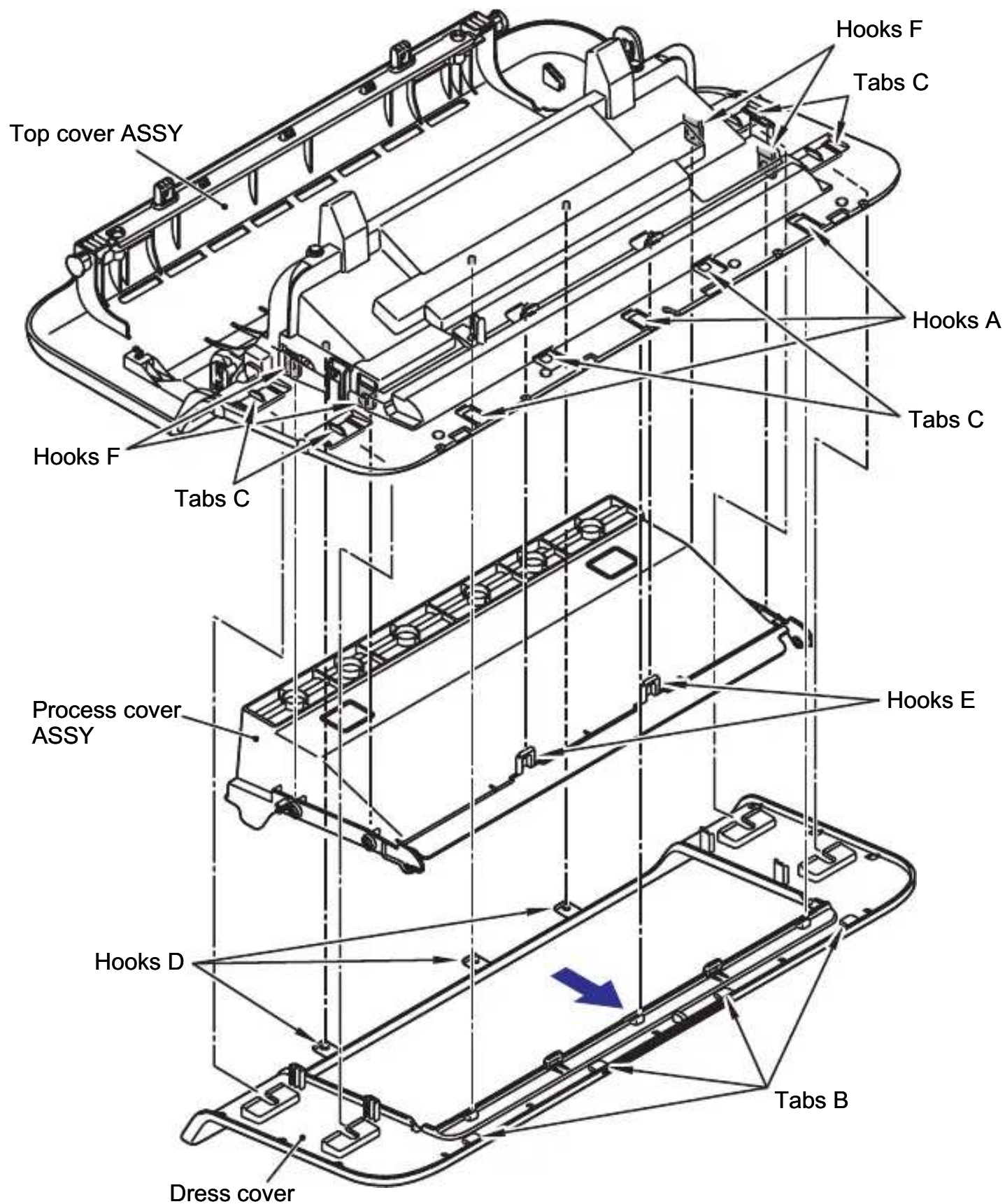

Fig. 2-7

7.4 Tray cover ASSY

- (1) Open the tray cover ASSY.
- (2) Bend the tray cover ASSY inward and remove the two bosses from the machine to remove the tray cover ASSY from the machine.
- (3) Remove the paper rear guide from the hook at the center part of the tray cover ASSY and remove it from the machine.

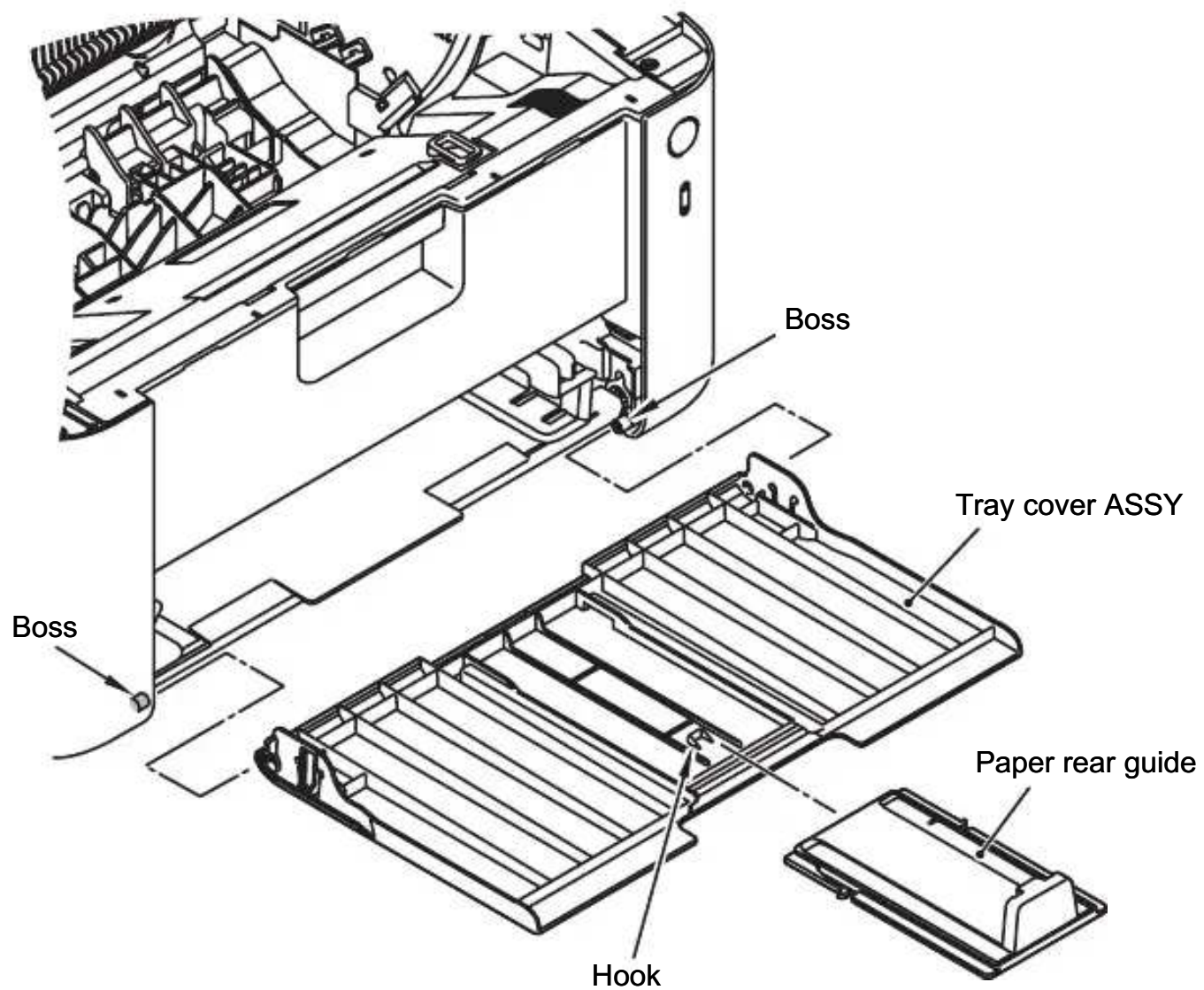

Fig. 2-8

7.5 Side cover L

- (1) Remove the two boss bushings at the rear side of the side cover L.
- (2) Lift the rib of the side cover L to release it from the boss and hook of the machine. Pull out the tab of the side cover L, and release the two hooks at the bottom to remove the side cover L.

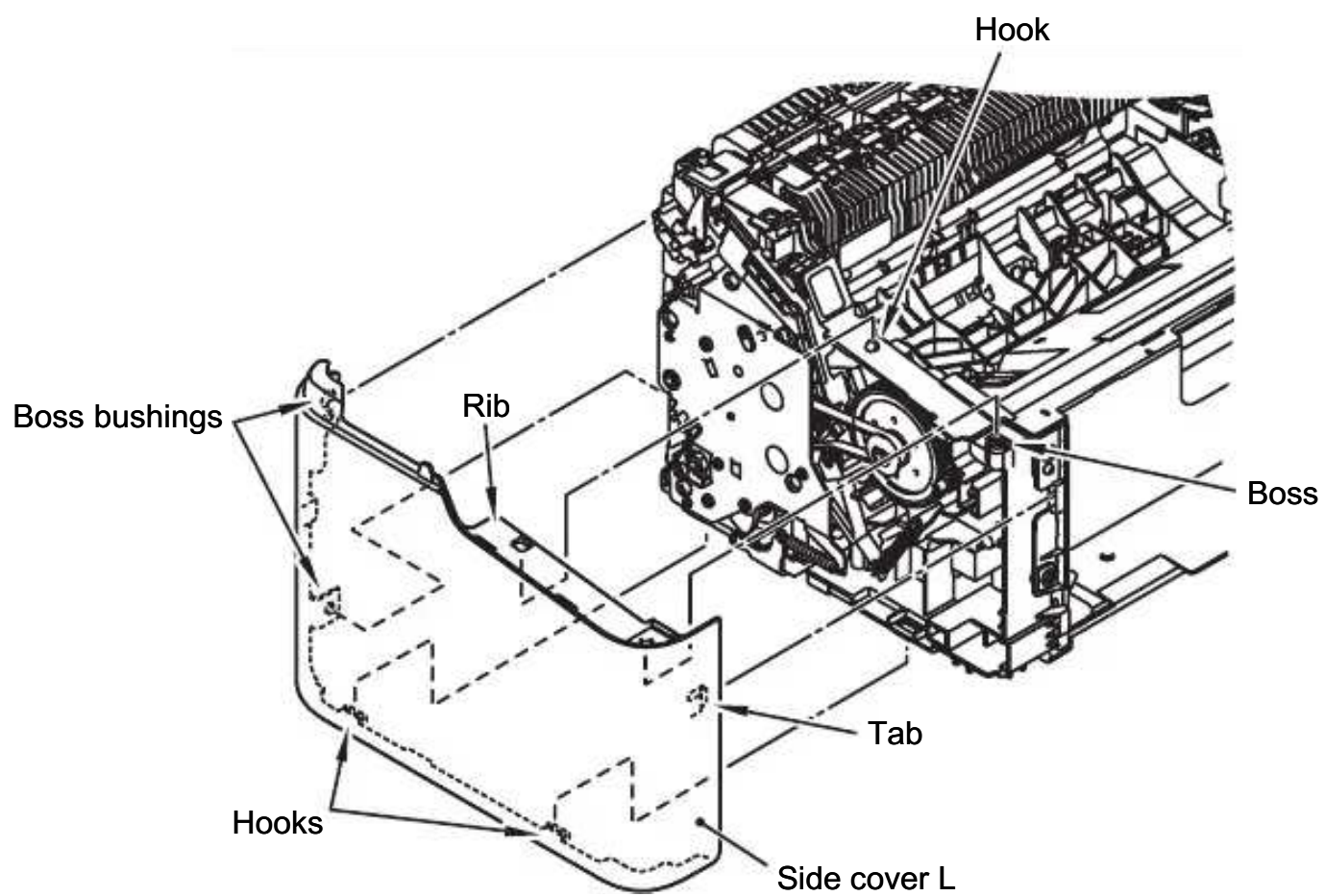

Fig. 2-9

Assembling Note:

- When assembling the side cover L, make sure that the develop joint link is on the inner side of the drive sub ASSY.

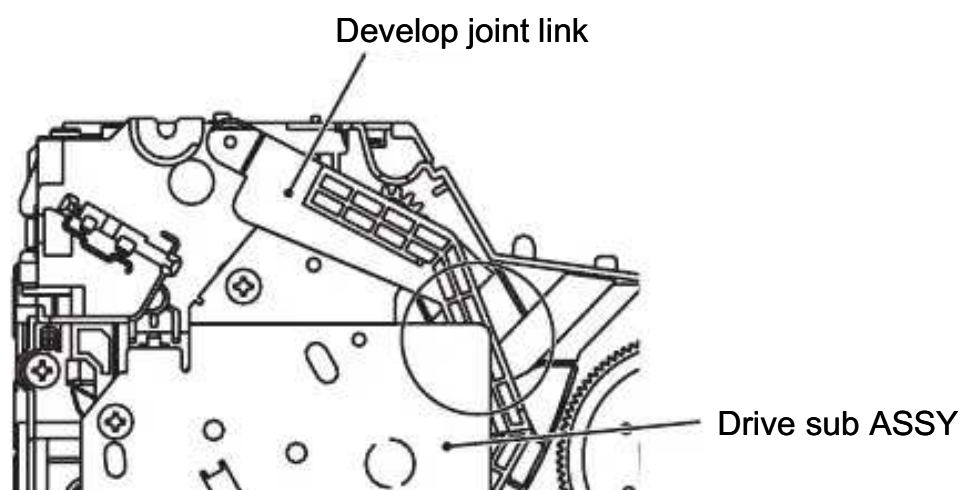

Fig. 2-10

7.6 Side cover R

- (1) Remove the boss bushing at the rear side of the side cover R.
- (2) Lift the rib of the side cover R to release it from the boss and hook of the machine. Pull out the tab of the side cover R and release the three hooks at the bottom to remove the side cover R.

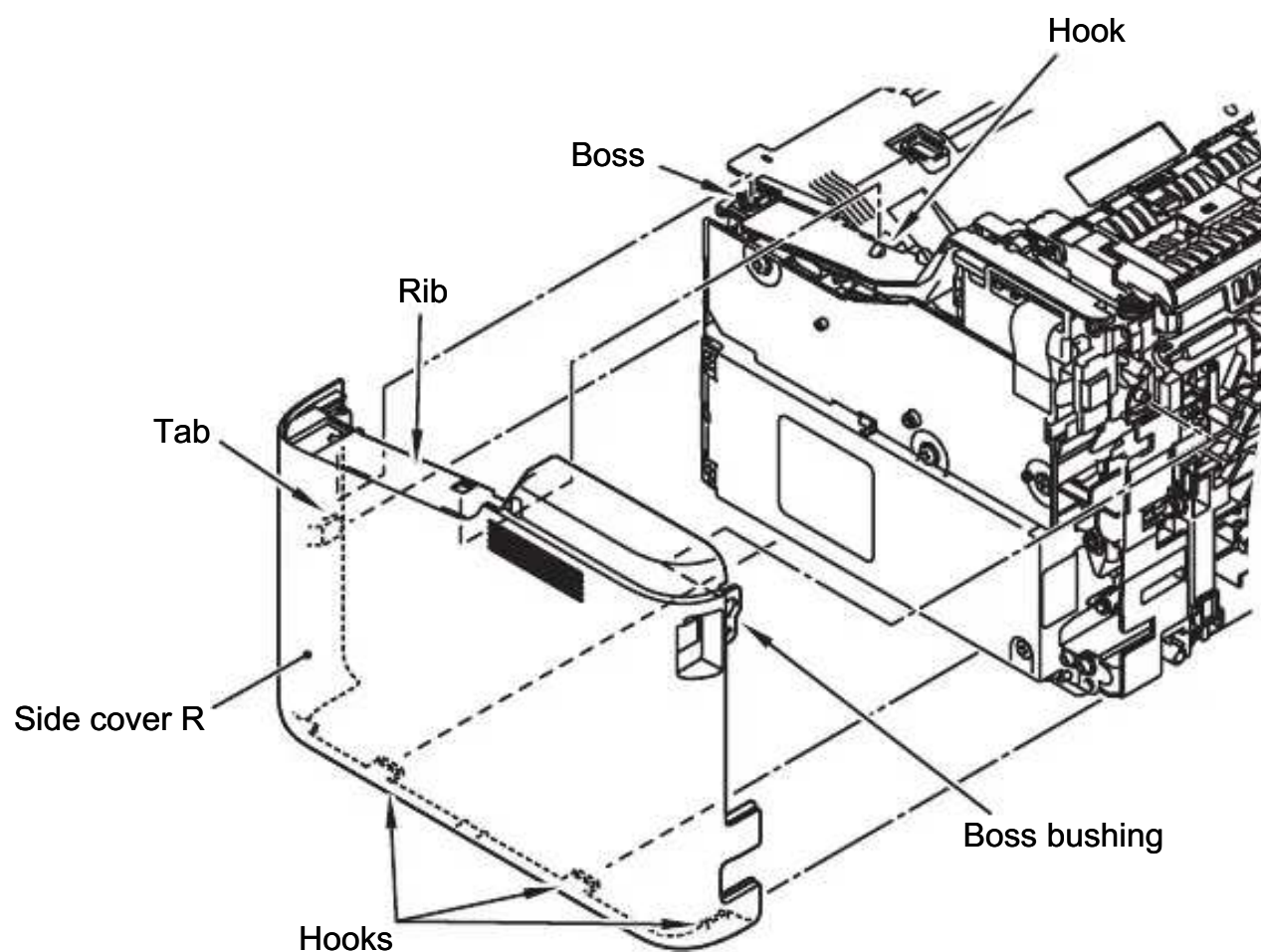

Fig. 2-11

- (3) Release the hook and open the switch key to remove it from the side cover R.

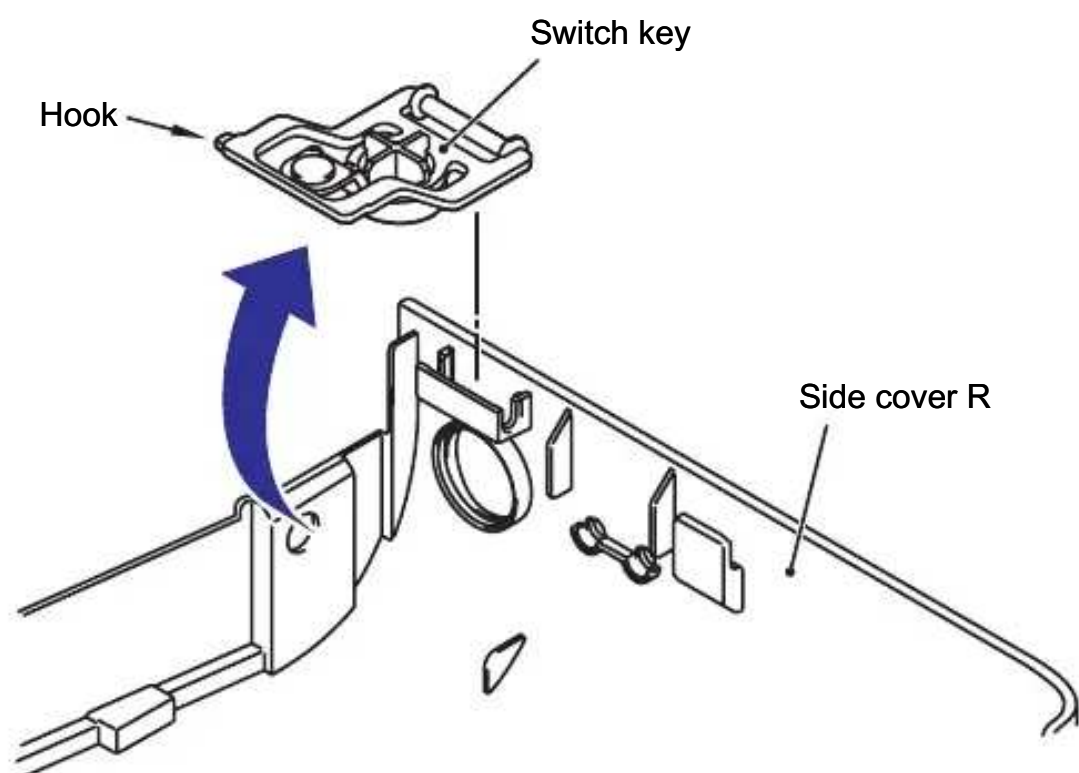

Fig. 2-12

7.7 Low voltage power supply PCB unit

Note:

- Do not pull out the low voltage PCB harness forcefully, to avoid it coming into contact with the high voltage power supply PCB ASSY. Remove the high voltage power supply PCB ASSY first to avoid it getting damaged.

- (1) Remove the four taptite bind B M4x12 screws.
- (2) Remove the two taptite cup S M3x8 SR screws.
- (3) Remove the screw pan (S/P washer) M3.5x6 screw to remove the low voltage shield plate cover and the low voltage insulation sheet.

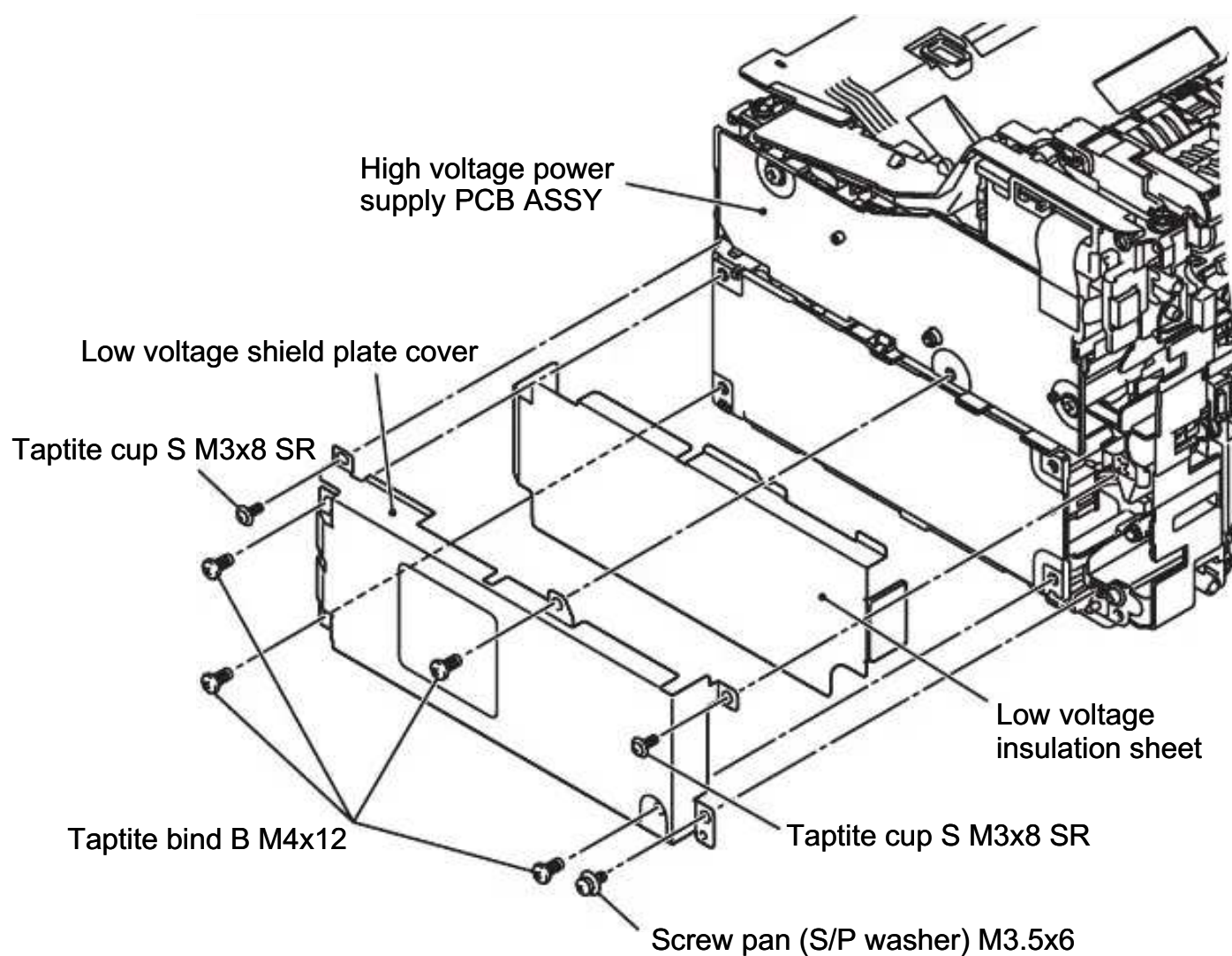

Fig. 2-13

- (4) Remove the screw pan (S/P washer) M3.5x6 screw to release the ground harness.
- (5) Remove the low voltage power supply PCB unit from the machine.
- (6) Disconnect the heater harness and the low voltage PCB harness from the low voltage power supply PCB unit.

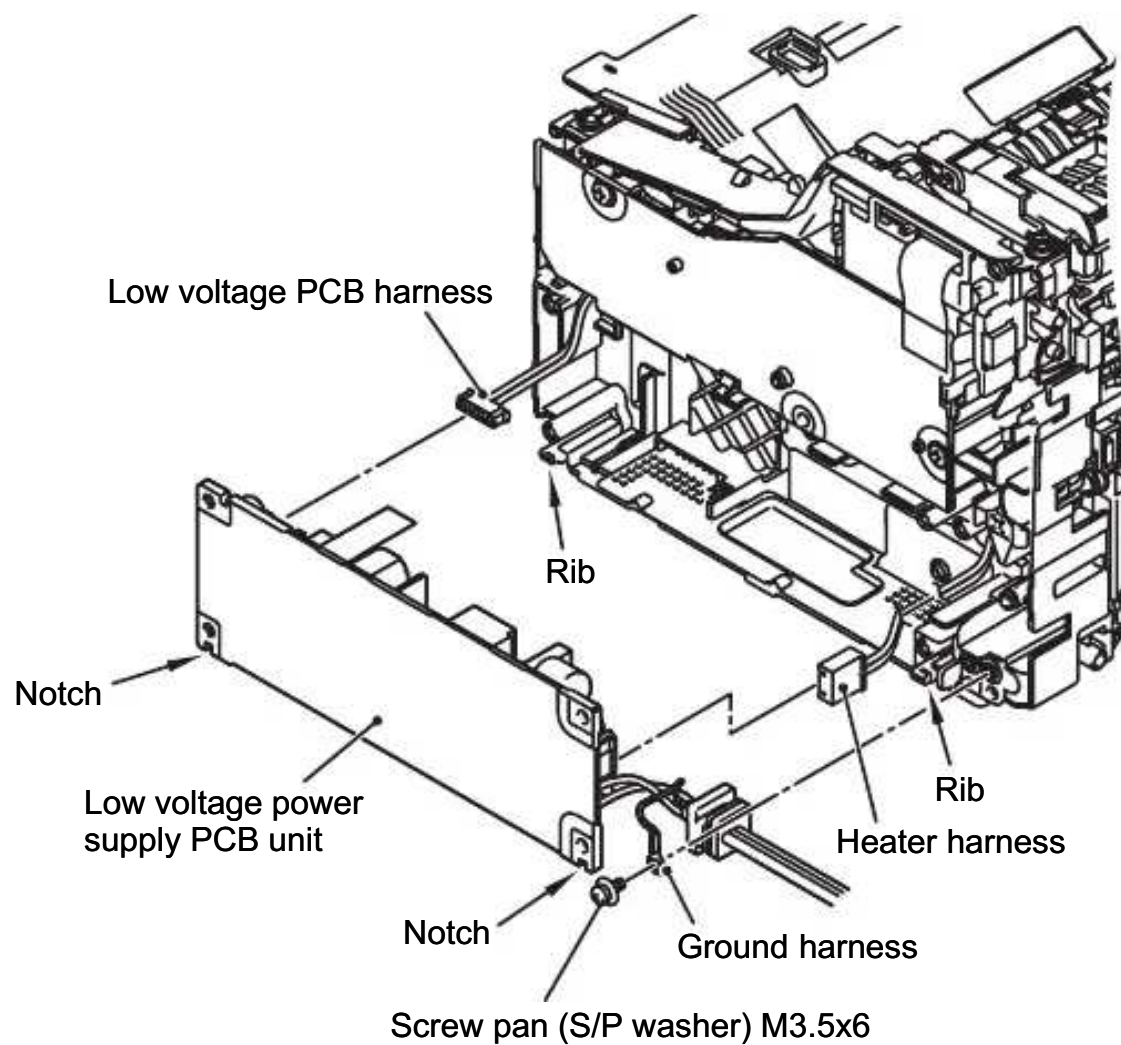
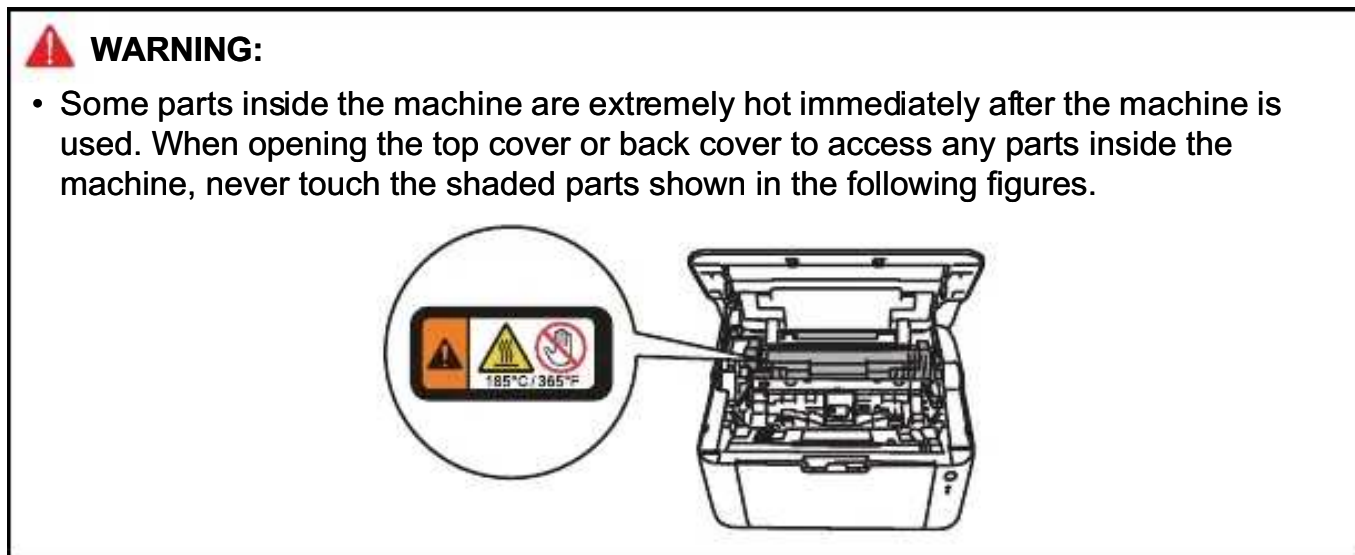

Fig. 2-14

Assembling Note:

- When assembling the low voltage power supply PCB unit, engage the two notches of the PCB with the two ribs of the machine.
- After the assembly, refer to "3. IF YOU REPLACE THE LOW VOLTAGE POWER SUPPLY PCB UNIT" in chapter 3 to configure each setting.

7.8 Fuser unit



- (1) Remove the two taptite pan B M4x14 screws.
- (2) Disconnect the center thermistor harness from the main PCB ASSY, and release it from the securing fixtures.
- (3) Release the heater harness from the securing fixtures, and remove the fuser unit from the machine.
- (4) Remove the taptite pan B M3x8 screw, and remove the insulation roof from the fuser unit.

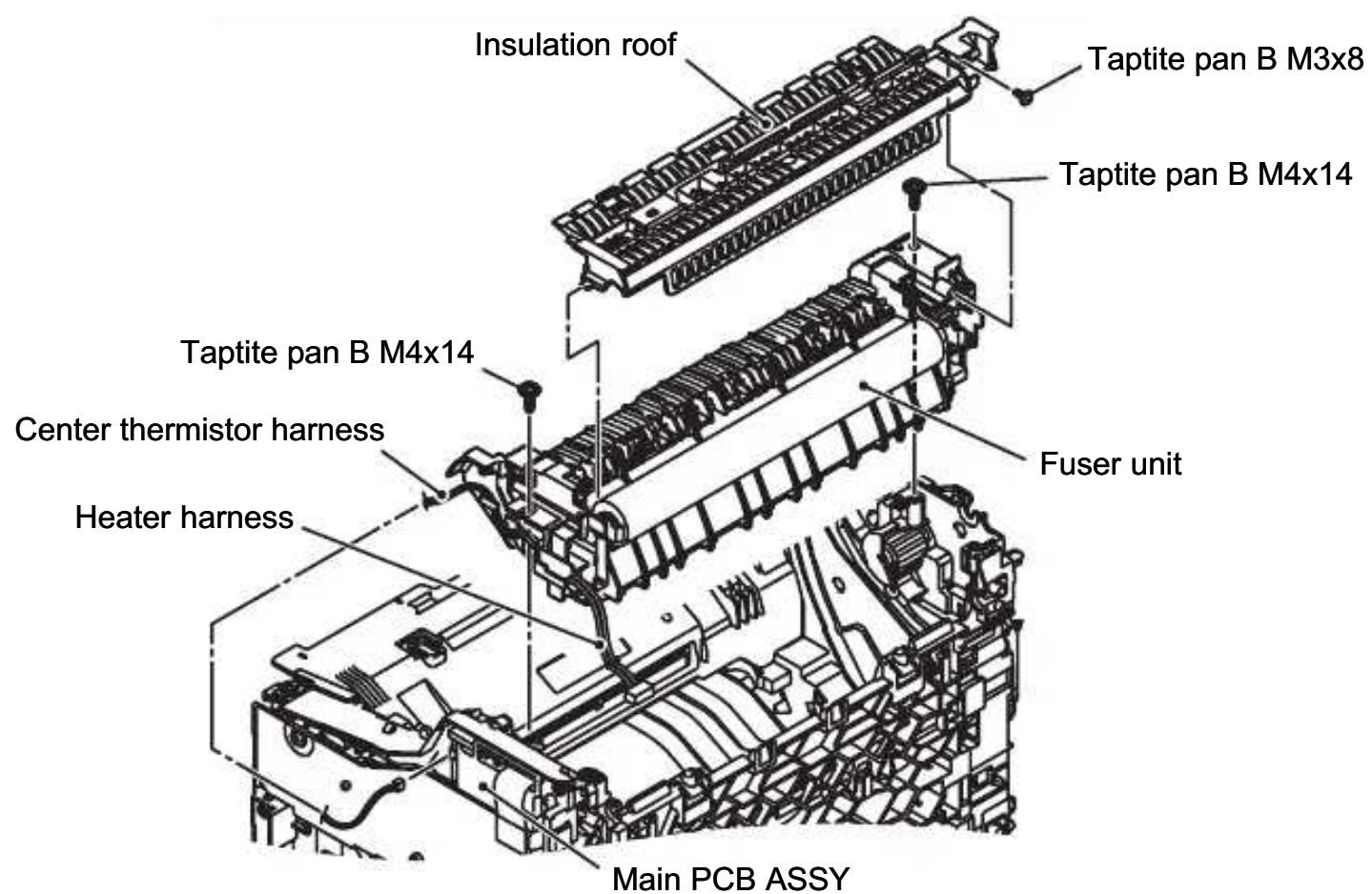

Fig. 2-15

Harness routing: Refer to "1. Main PCB ASSY / low voltage power supply PCB unit / fuser unit".

Assembling Note:

- Do not use the fuser unit for DCP-1510/1511/1512/1518, MFC-1810/1811/1813/1815/1818. Heater harnesses of the fuser unit for those models are longer than the one for this model. It could come into contact with other parts around the securing fixture, result in safety problems.

7.9 High voltage power supply PCB ASSY

- (1) Disconnect the high voltage PCB flat cable from the main PCB ASSY.

Note:

- After disconnecting the flat cable, check that the cable is not damaged at the end or short-circuited. When connecting the flat cable, do not insert it at an angle. After insertion, check that the cable is not at an angle.

- (2) Remove the two taptite bind B M4x12 screws.

- (3) Remove the two hooks to remove the high voltage power supply PCB ASSY from the machine.

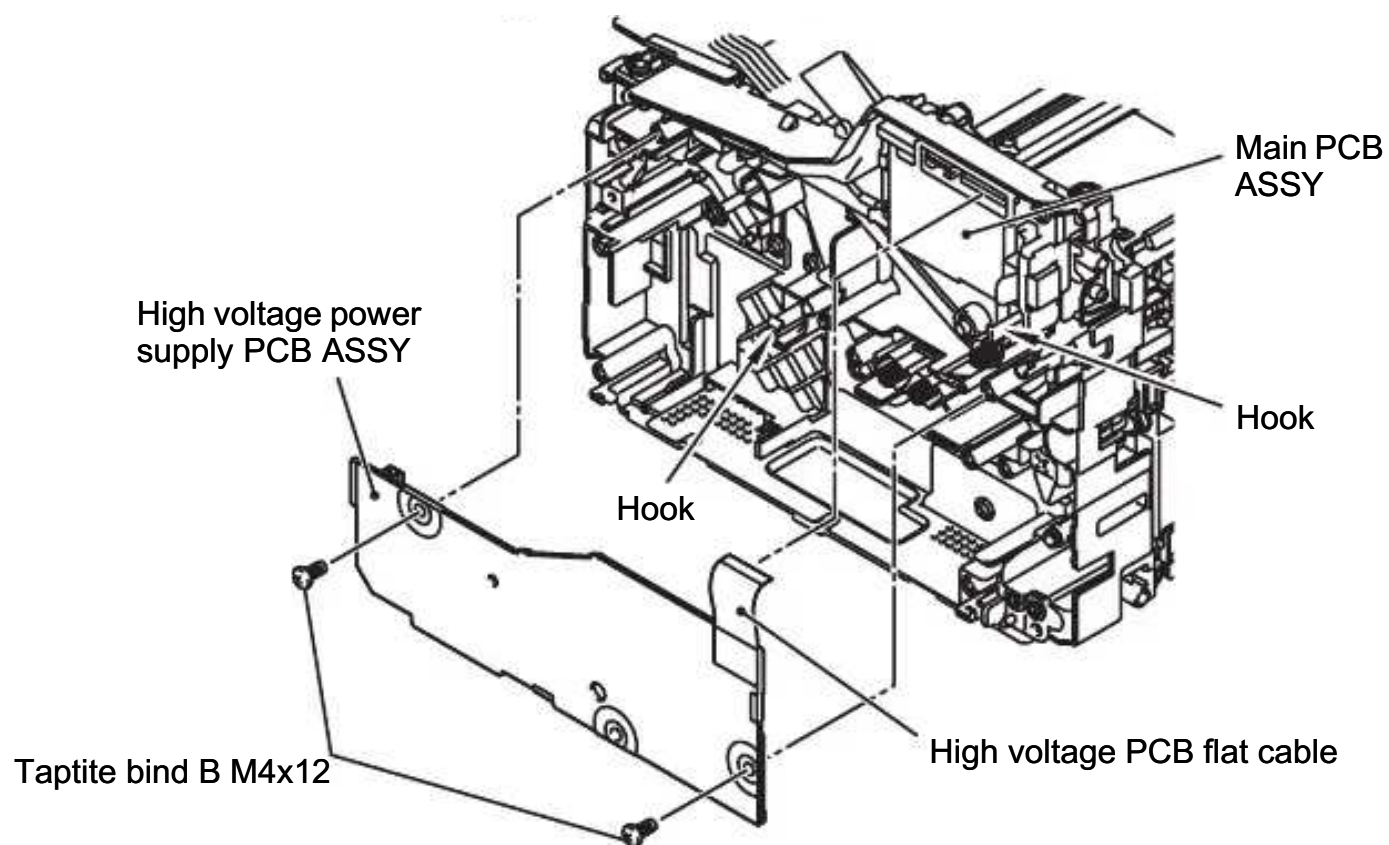

Fig. 2-16

Assembling Note:

- When removing the high voltage power supply PCB ASSY, electrode or electrode springs will come off. When assembling the high voltage power supply PCB ASSY, make sure that the electrode and electrode springs are assembled.
- Attach it by engaging the slits of the electrode with the ribs of the machine.
- Make sure that the spring is inserted fully into the end of the electrode.
- When assembling the high voltage power supply PCB ASSY, make sure that the toner cartridge and the drum unit have been removed. They could twist the electrode.

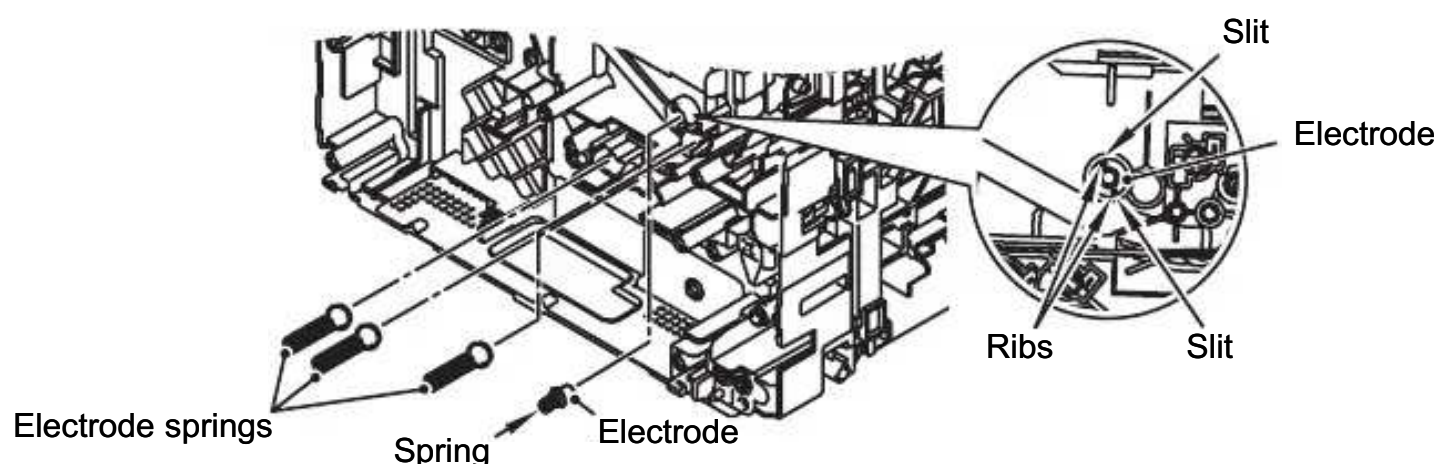

Fig. 2-17

7.10 Main PCB ASSY

- (1) Remove the bottom of the main PCB insulation sheet and peel it.
- (2) Disconnect all harnesses and flat cables from the main PCB ASSY.
- (3) Remove the three taptite cup S M3x6 SR screws to remove the ground harness, the main PCB ASSY, and the main PCB insulation sheet from the machine.

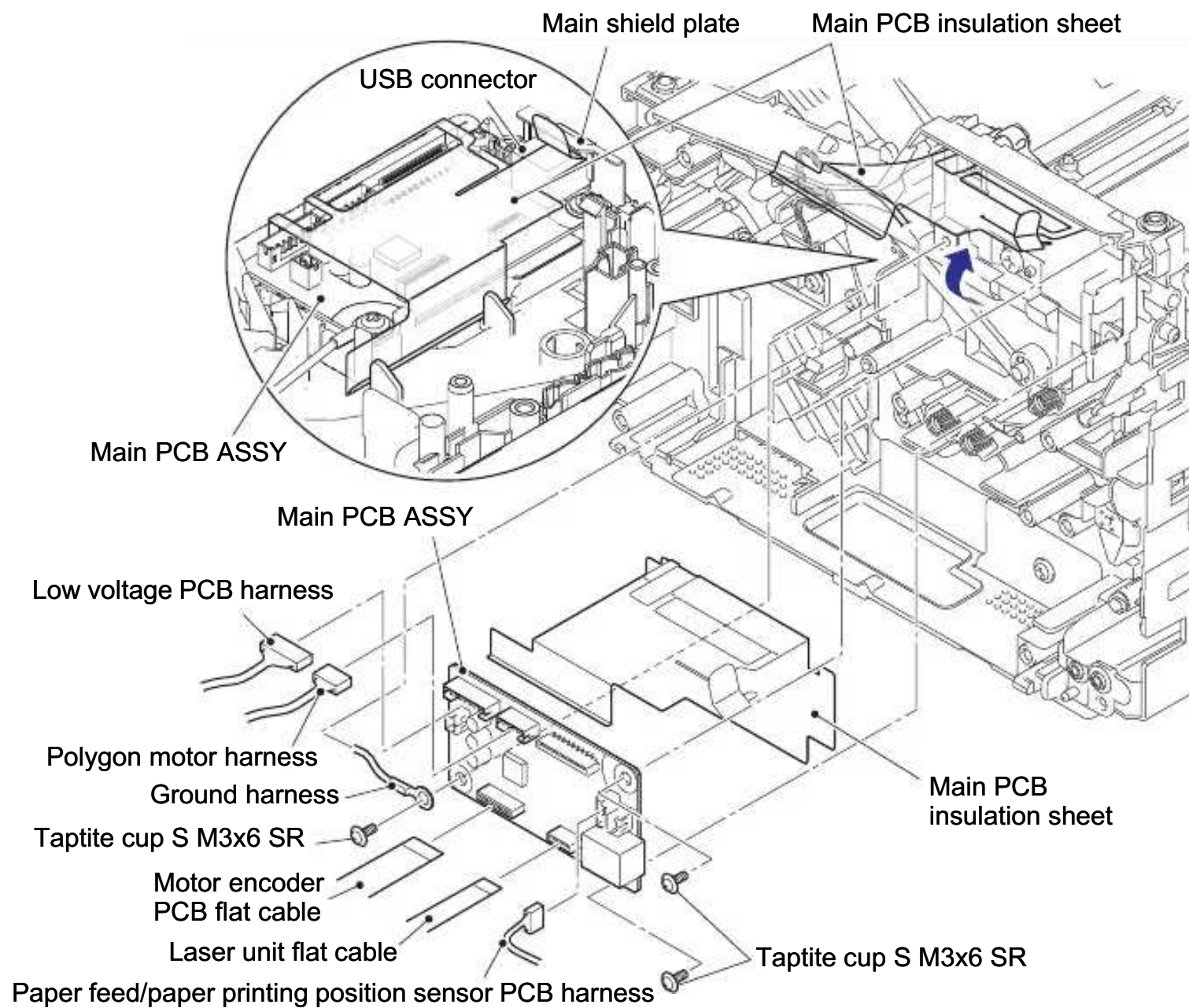

Fig. 2-18

Harness routing: Refer to "1. Main PCB ASSY / low voltage power supply PCB unit / fuser unit".

Note:

- Make sure that the main PCB ASSY is secured by screws when connecting or disconnecting harnesses and flat cables.
- After disconnecting flat cables, check that each cable is not damaged at its end or short-circuited. When connecting flat cables, do not insert them at an angle. After insertion, check that the cables are not at an angle.

Assembling Note:

- Insert the main PCB insulation sheet into the gap between the USB connector and the main shield plate.
- Attach the main PCB insulation sheet and the main PCB ASSY in the order as shown in the figure above.
- After the assembly, refer to "1. IF YOU REPLACE THE MAIN PCB ASSY" in chapter 3 to configure each setting.

7.11 Front cover

- (1) Remove the four taptite bind B M4x12 screws.
- (2) Release the two hooks at the bottom of the laser unit cover. Remove the laser unit cover and the front cover from the machine by turning them to the direction of the arrow.
- (3) Release the three hooks of the front cover to remove it from the laser unit cover.

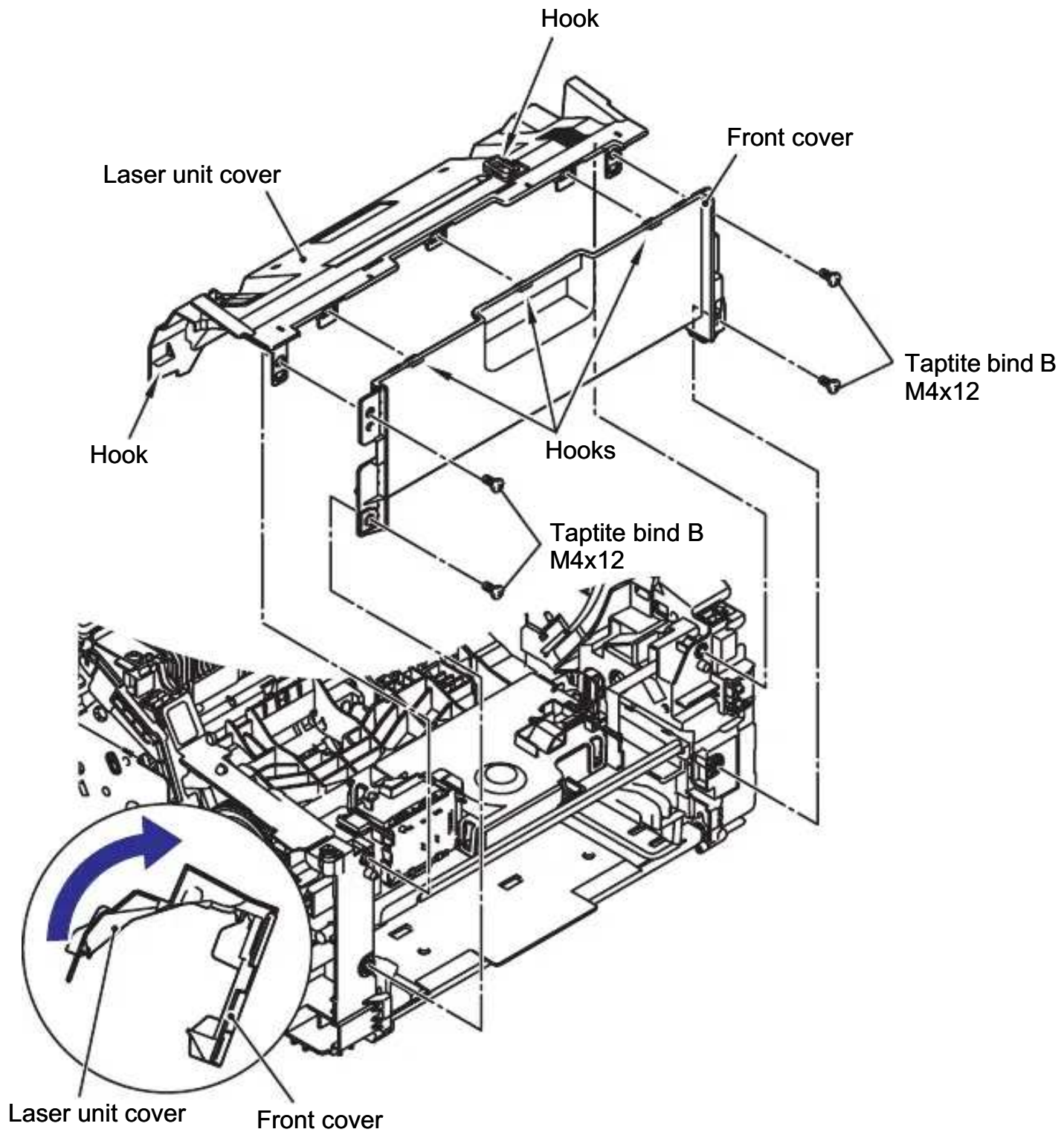

Fig. 2-19

7.12 Laser unit

- (1) Release the laser unit flat cable from the securing fixtures, and disconnect it from the laser unit.

Note:

- After disconnecting the flat cable, check that the cable is not damaged at the end or short-circuited. When connecting the flat cable, do not insert it at an angle. After insertion, check that the cable is not at an angle.

- (2) Release the polygon motor harness from the securing fixtures, and disconnect it from the laser unit.
- (3) Release the motor encoder PCB flat cable from the securing fixtures.
- (4) Remove the three taptite cup S M3x8 SR screws to remove the laser unit from the machine.

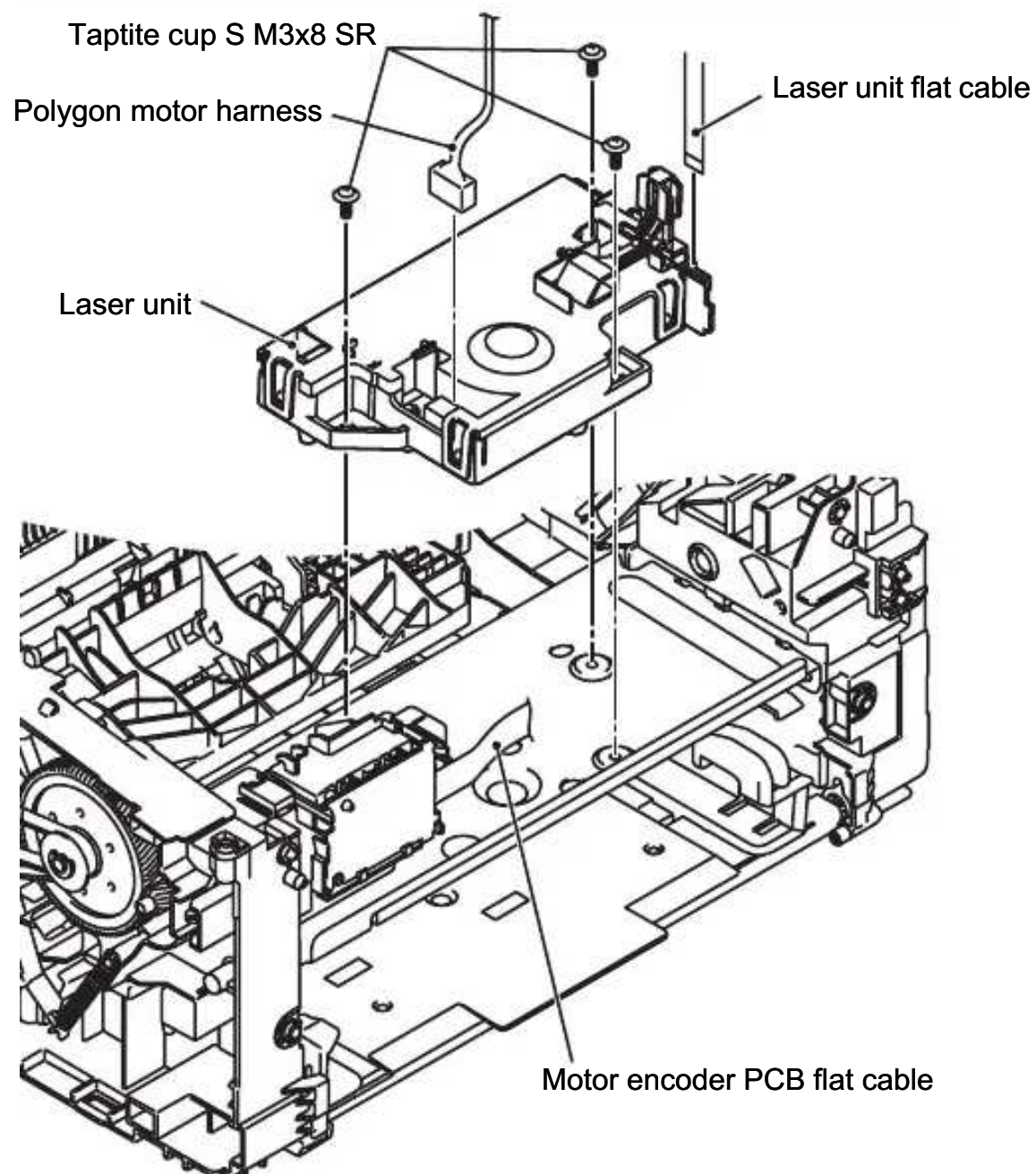

Fig. 2-20

Harness routing: Refer to "1. Main PCB ASSY / low voltage power supply PCB unit / fuser unit" and "2. Laser unit / motor encoder PCB ASSY".

Assembling Note:

- Fold the laser unit flat cable as shown in the figure below.

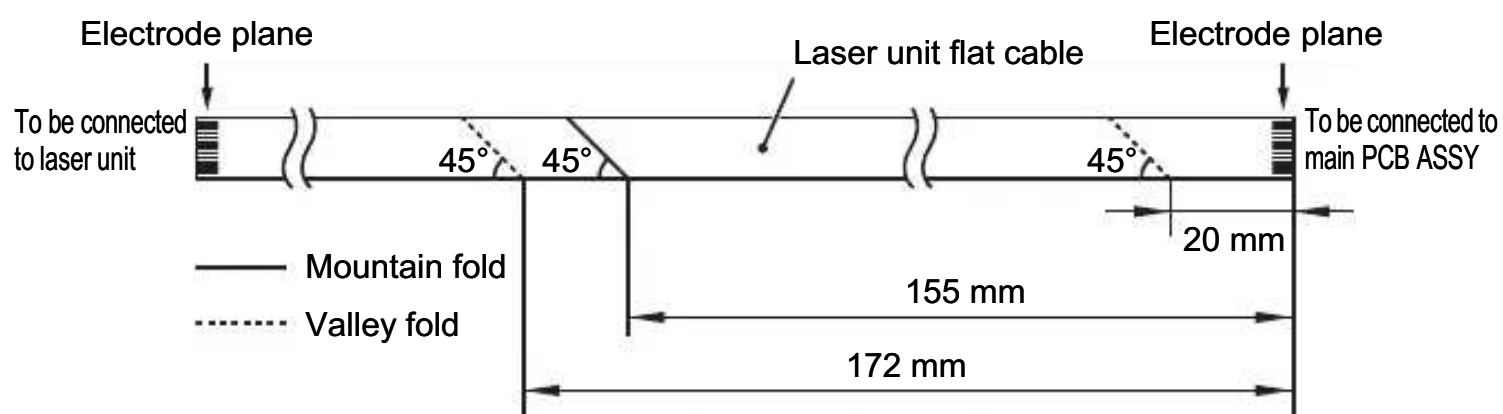

Fig. 2-21

Assembling Note:

- If you replaced the laser unit, attach the serial number label of the laser unit onto the location shown in the figure below.
- After the assembly, refer to **"2. IF YOU REPLACE THE LASER UNIT"** in chapter 3 to enter the adjusted value of the laser unit.

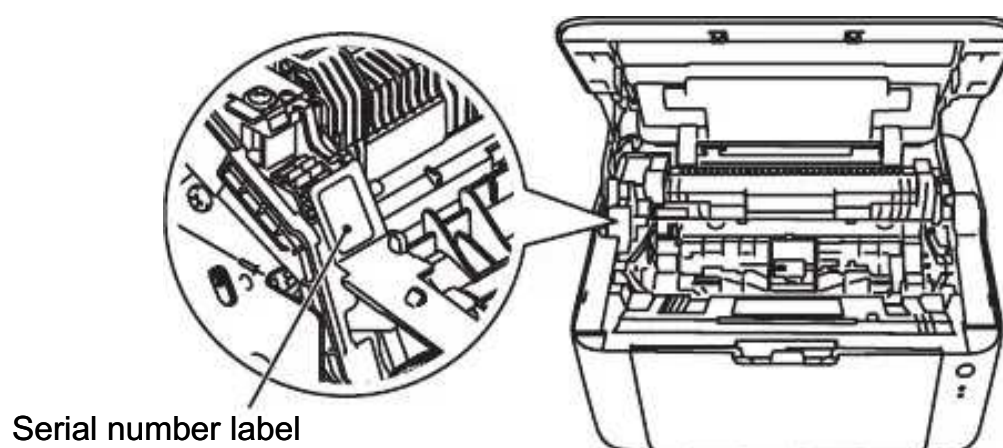

Fig. 2-22

7.13 Motor encoder PCB ASSY

- (1) Disconnect all harnesses and flat cable from the motor encoder PCB ASSY.

Note:

- After disconnecting the flat cable, check that the cable is not damaged at the end or short-circuited. When connecting the flat cable, do not insert it at an angle. After insertion, check that the cable is not at an angle.

- (2) Release the two hooks to remove the motor encoder PCB ASSY from the machine.

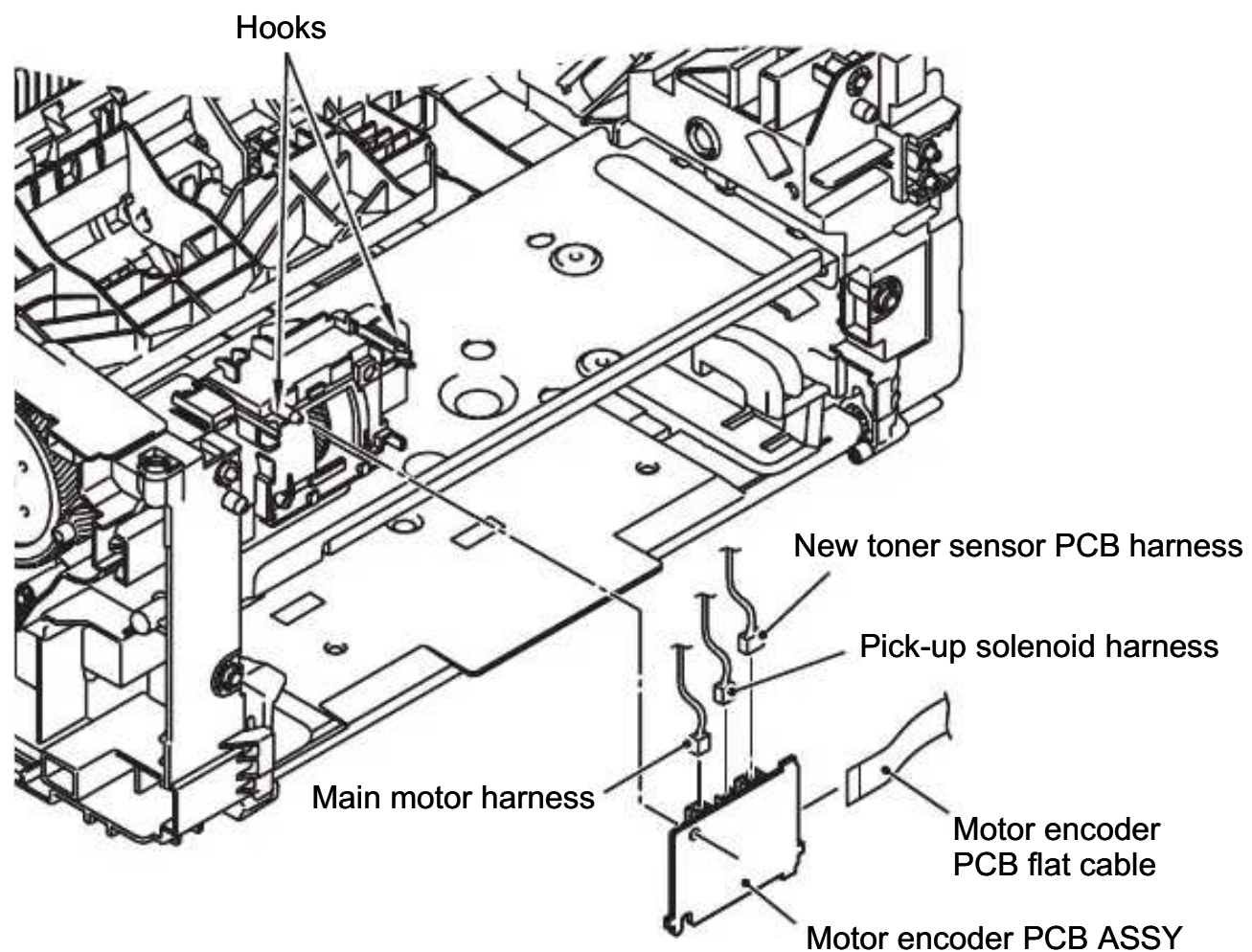

Fig. 2-23

Harness routing: Refer to "2. Laser unit / motor encoder PCB ASSY" and "5. New toner sensor PCB ASSY / pick-up solenoid".

Assembling Note:

- Fold the motor encoder PCB flat cable as shown in the figure below.

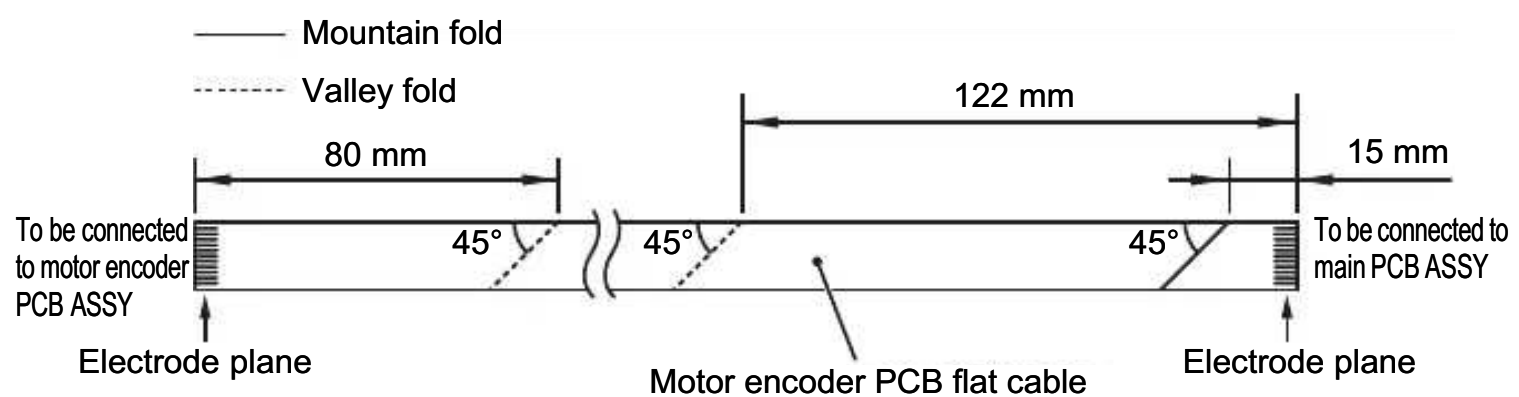

Fig. 2-24

7.14 Eject sensor PCB ASSY

- (1) Disconnect the eject sensor PCB harness from the paper feed/paper printing position sensor PCB ASSY, and release it from the securing fixtures.
- (2) Release the two hooks, and remove the eject sensor PCB ASSY from the machine.

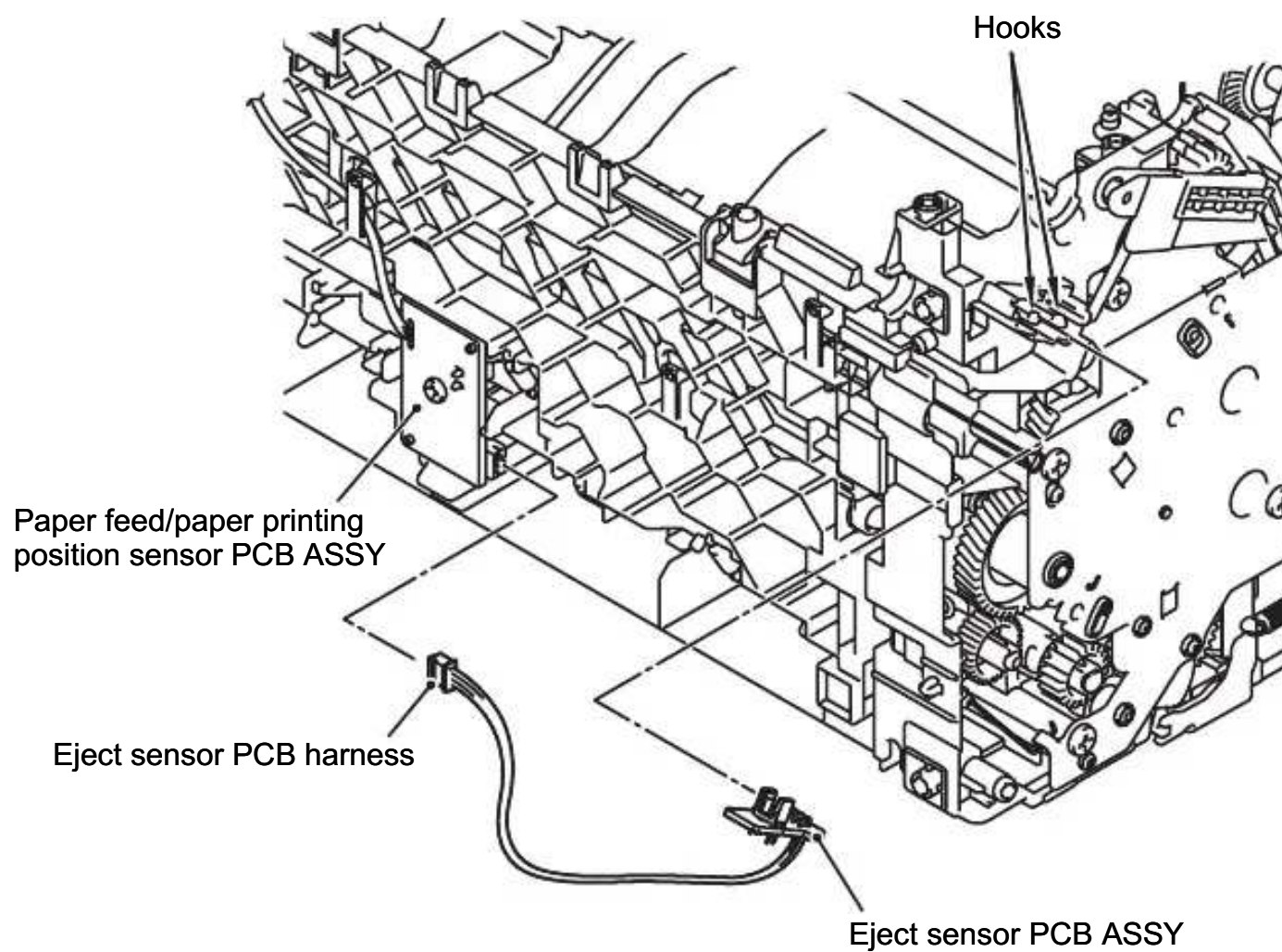

Fig. 2-25

Harness routing: Refer to [“3. Eject sensor PCB ASSY”](#).

7.15 Paper feed/paper printing position sensor PCB ASSY

- (1) Release the paper feed/paper printing position sensor PCB harness from the securing fixtures.
- (2) Remove the taptite bind B M3x10 screw to remove the paper feed/paper printing position sensor PCB ASSY from the machine.

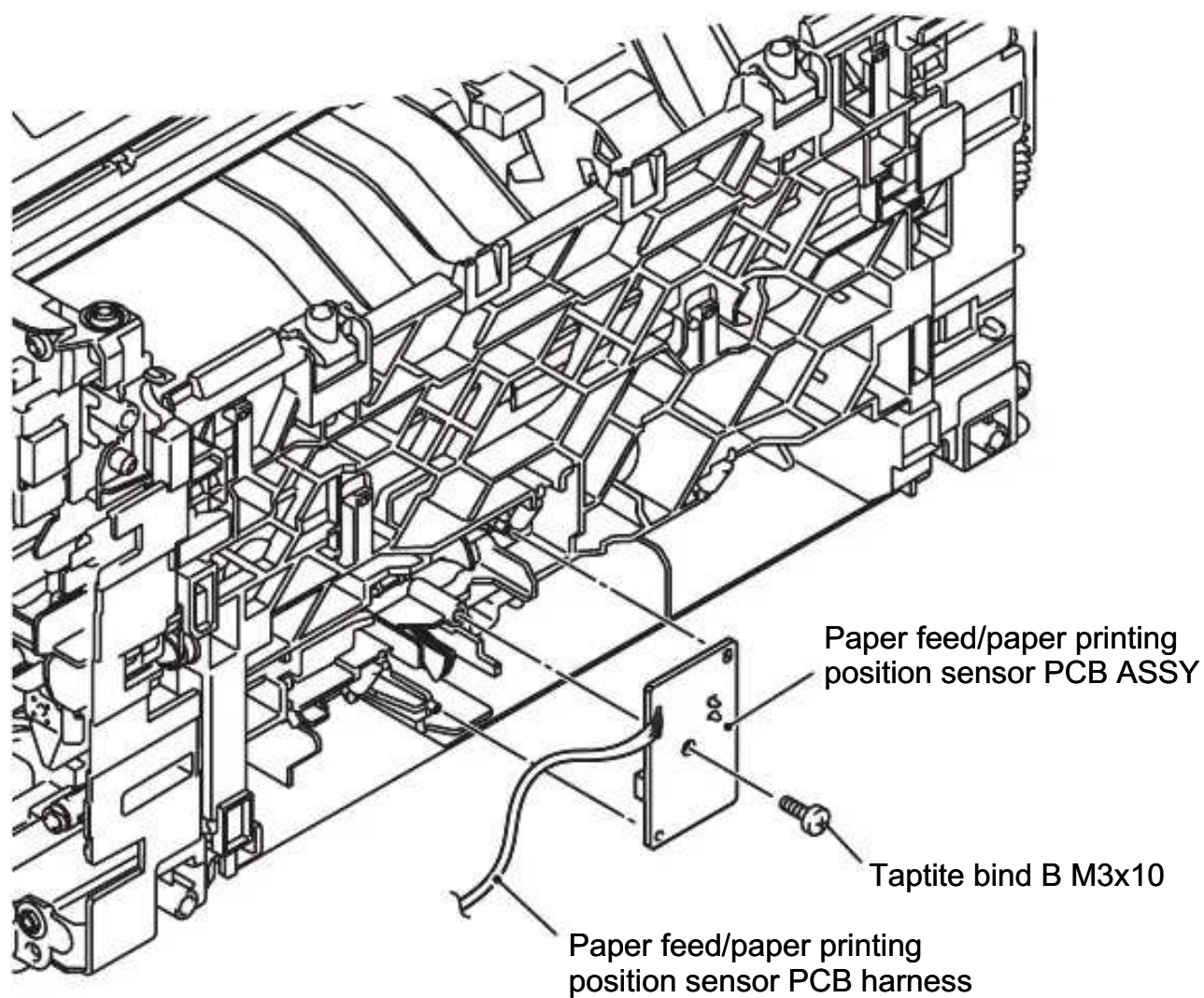

Fig. 2-26

Harness routing: Refer to "4. Paper feed/paper printing position sensor PCB ASSY".

7.16 New toner sensor PCB ASSY

Note:

- Make sure that the fuser unit is at room temperature to avoid the frame deforming due to heat.

- (1) Turn the machine so that the left side of the machine faces upward.
- (2) Remove the plate up spring from the plate up plate and the drive sub ASSY.

Note:

- Be careful not to uncoil the spring.

- (3) Remove the four taptite bind B M4x12 screws.
- (4) Remove the paper feed FG spring from the drive sub ASSY.
- (5) Release the hook, and remove the drive sub ASSY from the machine by bending the chute earth spring inward. Remove the motor drive belt from the develop gear of the drive sub ASSY.
- (6) Release the new toner sensor PCB harness from the securing fixtures.
- (7) Release the two hooks to remove the new toner sensor PCB ASSY.

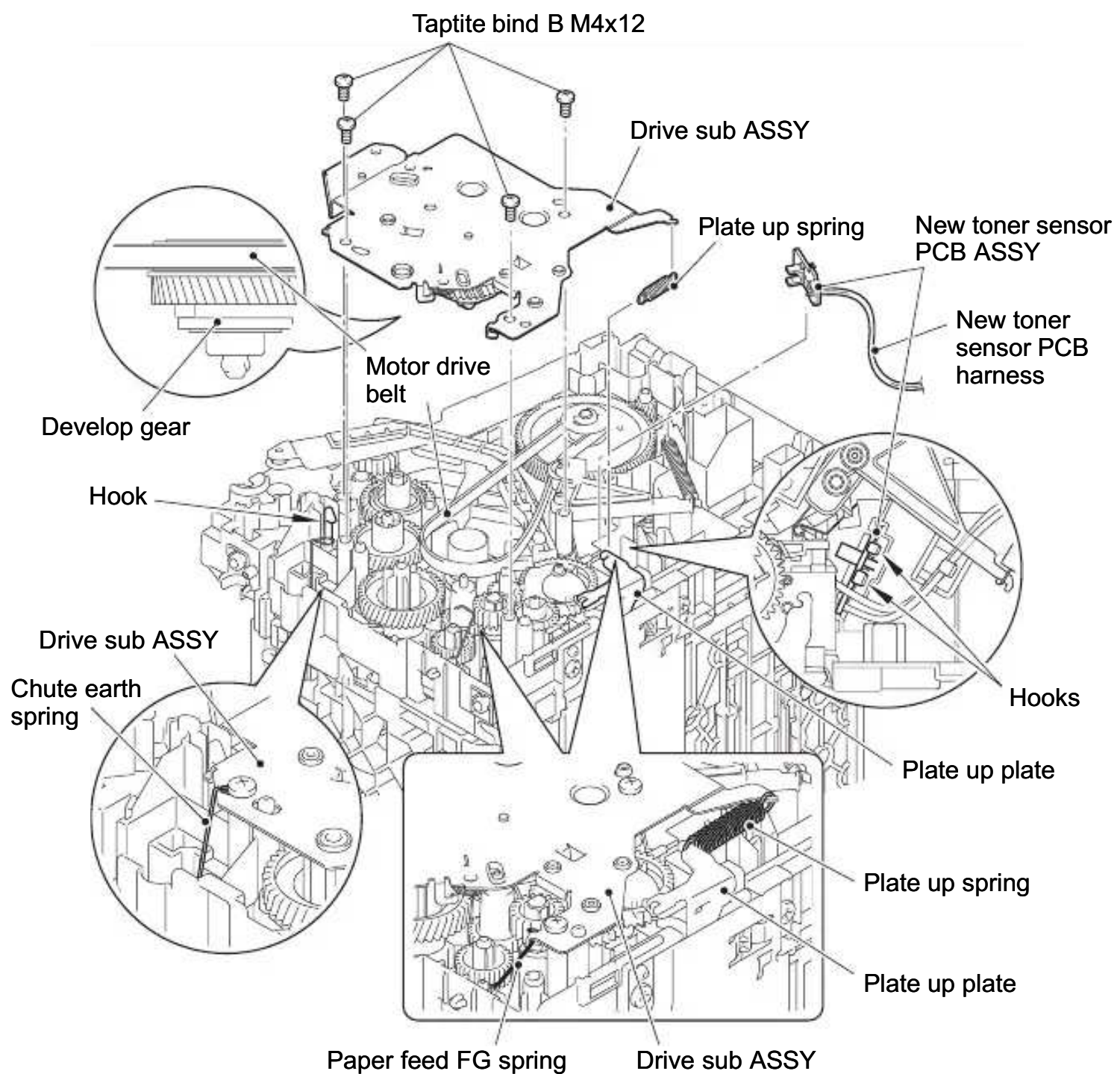

Fig. 2-27

Harness routing: Refer to "5. New toner sensor PCB ASSY / pick-up solenoid".

CHAPTER 3 ADJUSTING AND UPDATING SETTINGS AS REQUIRED AFTER PARTS REPLACEMENT

1. IF YOU REPLACE THE MAIN PCB ASSY

2. IF YOU REPLACE THE LASER UNIT

3. IF YOU REPLACE THE LOW VOLTAGE POWER SUPPLY PCB UNIT

1. IF YOU REPLACE THE MAIN PCB ASSY

<What to do after replacement>

- Installing firmware (main firmware)
- Setting by country
- Setting serial number and entering adjusted value of laser unit

■ What you need to prepare

- (1) One USB cable
- (2) Create a temporary folder on the C drive of the computer (Windows[®] XP or later).
- (3) Service setting tool (BrUsbsn.zip)
Copy this file into the temporary folder created on the C drive. Extract the copied file and double-click "BrUsbsn.exe" to start it.
- (4) Download utility (FILEDG32.EXE)
Copy this file into the temporary folder created on the C drive.
- (5) Maintenance driver (MaintenanceDriver.zip)
When the maintenance driver is not installed on the computer, copy this file into the temporary folder created on the C drive, and extract the copied file.
- (6) Firmware

Main firmware (E.g.) LZ4326_\$.blf	LZ4326: First six digits of the part number of the firmware \$: Alphabetic character representing the revision version of the firmware
---------------------------------------	---

- (7) Setting by country tool (SpecificationSetting.exe)
Copy this file into the temporary folder created on the C drive.

1.1 Installing Firmware (Main Firmware)

1.1.1 Checking firmware version





Check whether the firmware installed on the main PCB is the latest version. If it is the latest version, there is no need to reinstall the firmware.

If it is not, be sure to install the firmware to the main PCB as described in “1.1.2 Installing firmware (Main program)” in this chapter.





<How to check firmware version>

Print the Printer Settings to check firmware version by pressing the  button three times continuously with the top cover closed.

1.1.2 Installing firmware (Main program)

- (1) Press and hold the  button to turn OFF the machine with the AC cord plugged into a socket.
- (2) Press and hold the  button and check that the Ready and Error LEDs are lit. Then open the top cover and check that the Error LED goes out and only the Ready LED is lit.
- (3) Take out the drum unit, check that the Error LED is lit, and return the drum unit.
- (4) Check that the Ready and Error LEDs are lit, then release the  button. Check that all LEDs go out and close the top cover.
- (5) Press and hold the  button for at least two seconds and check that the Error LED is lit. By releasing the  button, the Error LED goes off and only the Ready LED remains lit.
- (6) Connect the machine to your computer using the USB cable.
- (7) Open the temporary folder and double-click “FILEDG32.EXE” to start it, and select “Brother Maintenance USB Printer”.
- (8) Drag and drop the main firmware (LZ4326_\$.bif) in the same folder onto the “Brother Maintenance USB Printer” icon. The main firmware file is loaded to the machine, and installing to the flash ROM starts.
- (9) The Ready and Error LEDs flash randomly during writing. When completed, the machine restarts and returns to the ready state automatically. Do not disconnect the USB cable or turn OFF the power switch of the computer until installing is completed.
- (10) Turn OFF the machine, and disconnect the USB cable.

1.2 Setting by Country

- (1) Check that the power switch is turned OFF with AC cord connected to the machine.
- (2) Press and hold the  button (keep holding the  button for procedure (2)) and check that the Ready and Error LEDs are lit. Open the top cover to check that the Error LED goes out and only the Ready LED is lit.
Take out the drum unit and check that the Error LED is lit. Return the drum unit and check that the Error LED goes out.
- (3) Release the  button and check that all LEDs go out, and then close the top cover.
- (4) Press and hold the  button at least two seconds and check that the Error LED is lit. Release the  button and check that the Error LED goes out and the Ready LED is lit after flashing several times.
- (5) Connect the machine to your computer using the USB cable.
- (6) Select “Start” > “All Programs” > “Accessories” > “Command Prompt” on your computer and launch Command Prompt. The window shown below appears.

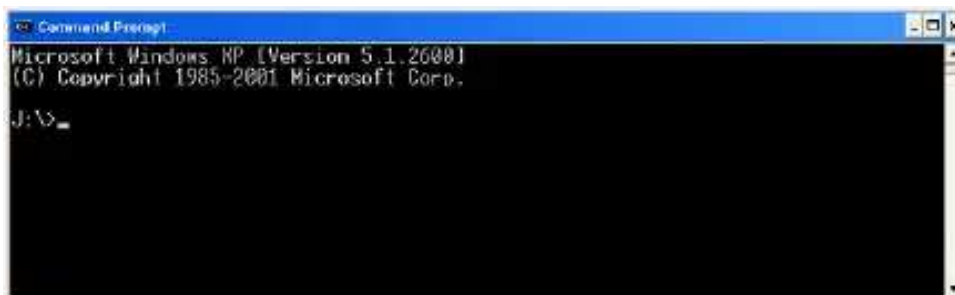

- (7) Drag and drop the “SpecificationSetting.exe” file onto the “Command Prompt” window. “Command Prompt” is shown as below.

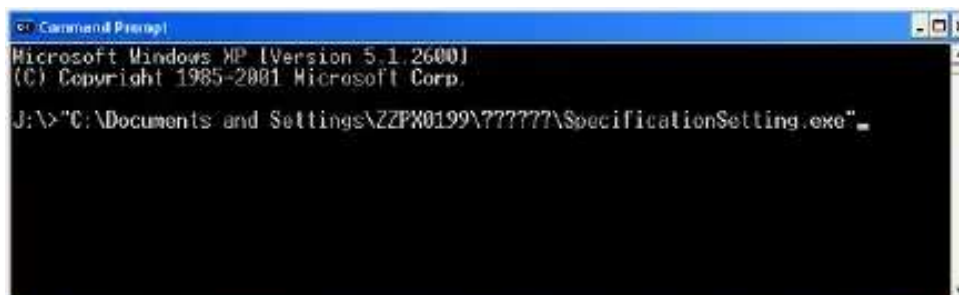

- (8) Refer to the next page to enter a space and country code right after “¥SpecificationSetting.exe” shown in the command prompt, and press the [Enter (Return)] key.
Setting by country is written to the machine.

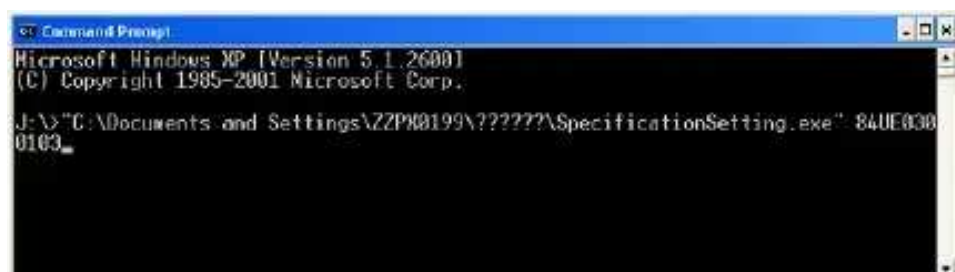

(The figure above is for German model: HL-1110)

- (9) Turn OFF the machine, and disconnect the USB cable.
- (10) Turn ON the machine. Press the  button three times while the machine is in the ready state to print the Printer Settings.



(11) Check the "AUTO POWER OFF" and "Toner Kind" fields in the Printer Settings (Refer to **"1. PRINTING PRINTER SETTINGS" in Chapter 4.**) to make sure that they are matched to the status presented in the setting by country table below.

■ **Setting by country code list**

Destination	Model	Country code	AUTO POWER OFF	Toner Kind*
Germany	HL-1110	84UE0300103	1 HOUR	STANDARD TONER
	HL-1112	84UE0300203	1 HOUR	STANDARD TONER
UK	HL-1110	84UE0300104	1 HOUR	STANDARD TONER
	HL-1112	84UE0300204	1 HOUR	STANDARD TONER
France	HL-1110	84UE0300155	1 HOUR	STANDARD TONER
	HL-1112	84UE0300255	1 HOUR	STANDARD TONER
Australia	HL-1110	84UE0300156	OFF	STANDARD TONER
Belgium	HL-1110	84UE0300155	1 HOUR	STANDARD TONER
	HL-1112	84UE0300255	1 HOUR	STANDARD TONER
Netherlands	HL-1110	84UE0300155	1 HOUR	STANDARD TONER
	HL-1112	84UE0300255	1 HOUR	STANDARD TONER
Switzerland	HL-1110	84UE0300110	1 HOUR	STANDARD TONER
Denmark	HL-1110	84UE0300113	1 HOUR	STANDARD TONER
	HL-1112	84UE0300213	1 HOUR	STANDARD TONER
Italy	HL-1110	84UE0300116	1 HOUR	STANDARD TONER
	HL-1112	84UE0300216	1 HOUR	STANDARD TONER
Vietnam	HL-1111	84UE0300119	OFF	STANDARD TONER.
China	HL-1118	84UE0300120	OFF	STANDARD TONER.
Taiwan	HL-1110	84UE0300123	OFF	STANDARD TONER
Turkey	HL-1111	84UE0300125	4 HOUR	STANDARD TONER
Indonesia	HL-1110	84UE0300129	OFF	STANDARD TONER
New Zealand	HL-1110	84UE0300156	OFF	STANDARD TONER
Argentina	HL-1110	84UE0300131	OFF	STANDARD TONER
	HL-1112	84UE0300231	OFF	STANDARD TONER
Chile	HL-1112	84UE0300236	OFF	STANDARD TONER
Brazil	HL-1112	84UE0300242	OFF	STANDARD TONER
Korea	HL-1110	84UE0300144	OFF	STANDARD TONER
India	HL-1111	84UE0300145	OFF	STANDARD TONER.
Mexico Russia	HL-1112	84UE0300246	OFF	STANDARD TONER
	HL-1110R	84UE0300148	1 HOUR	STANDARD TONER
	HL-1112R	84UE0300248	1 HOUR	STANDARD TONER
Pan-Nordic	HL-1110	84UE0300157	1 HOUR	STANDARD TONER
	HL-1112	84UE0300257	1 HOUR	STANDARD TONER
CEE	HL-1110E	84UE0300164	1 HOUR	STANDARD TONER
	HL-1112E	84UE0300264	1 HOUR	STANDARD TONER
Iberia	HL-1110	84UE0300165	1 HOUR	STANDARD TONER
Malaysia	HL-1110	84UE0300171	OFF	STANDARD TONER
Peru	HL-1112	84UE0300272	OFF	STANDARD TONER
UAE	HL-1110	84UE0300173	OFF	STANDARD TONER
Middle east and north Africa	HL-1110	84UE0300176	OFF	STANDARD TONER

* The only difference in Toner Kind status is whether the period (".") comes after STANDARD TONER or not.

1.3 Setting Serial Number and Entering Adjusted Value of Laser Unit

- (1) Connect the machine to your computer using the USB cable.
- (2) Check that the power switch is turned OFF. Press and hold the  button and check that the Ready and Error LEDs are lit. Then open the top cover and check that the Error LED goes out and only the Ready LED is lit. Take out the drum unit and check that the Error LED is lit. Check that the Ready and Error LEDs are lit and release the  button.
- (3) Check that all LEDs go out, then press and hold the  button for at least two seconds.
- (4) Check that the Error LED is lit and close the top cover.
- (5) Double-click “BrUsbsn.exe” that was copied into the temporary folder to start it. The “BrUsbSn” window shown on the right appears.
- (6) In the “Product Category” field, select “2 Mono-Laser”.
- (7) Select “2013_Printer”.
- (8) In the “Port” field, select the port number assigned to the “Brother Maintenance USB Printer”.
If the port number is unknown, follow the steps below to check it.
 - 1) Click “Start”, “Settings”, and “Printers and Faxes”. The “Printers and Faxes” window appears.
 - 2) Right-click the “Brother Maintenance USB Printer” icon.
 - 3) Click “Properties”. The “Brother Maintenance USB Printer Properties” window appears.
 - 4) Click the “Ports” tab. The Brother Maintenance USB Printer port number is displayed.
- (9) Enter the serial number (15 digits) of the machine in the “Serial No” field.
- (10) Enter the last five digits on the laser serial number label in the “Scanner Video Clk” field.

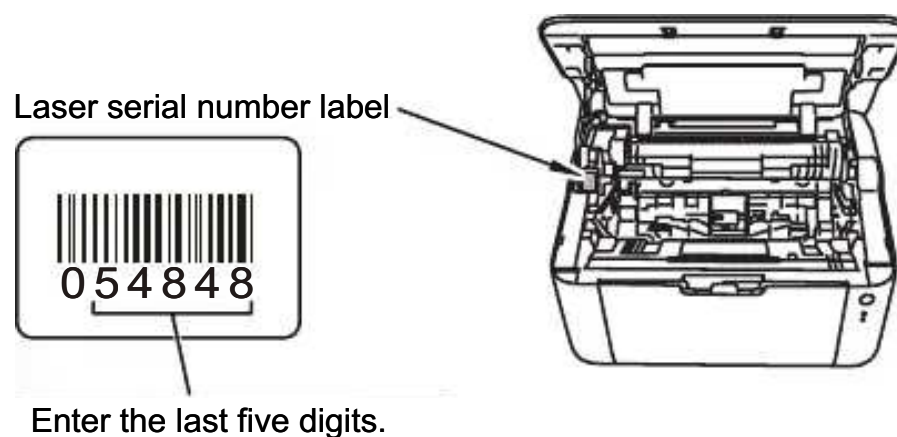

Fig. 3-1

- (11) Click the [OK] button, then confirmation screen appears. Check that the serial number and the adjusted value of the laser unit are correct and click the [Yes] button. The serial number and the adjusted value of the laser unit are written to the machine.
- (12) Turn OFF the power switch of the machine.

2. IF YOU REPLACE THE LASER UNIT



<What to do after replacement>

- Entering adjusted value of laser unit

■ What you need to prepare

- (1) One USB cable
- (2) Create a temporary folder on the C drive of the computer (Windows® XP or later).
- (3) Service setting tool (BrUsbsn.zip)
Copy this file into the temporary folder created on the C drive. Extract the copied file and double-click "BrUsbsn.exe" to start it.
- (4) Download utility (FILEDG32.EXE)
Copy this file into the temporary folder created on the C drive.
- (5) Maintenance driver (MaintenanceDriver.zip)
When the maintenance driver is not installed on the computer, copy this file into the temporary folder created on the C drive, and extract the copied file.

2.1 Entering Adjusted Value of Laser Unit

- (1) Turn OFF the power switch of the machine.
- (2) Connect the machine to your computer using the USB cable.
- (3) Check that the power switch is turned OFF. Press and hold the  button and check that the Ready and Error LEDs are lit. Then open the top cover and check that the Error LED goes out and only the Ready LED is lit. Take out the drum unit and check that the Error LED is lit. Check that the Ready and Error LEDs are lit and release the  button.
- (4) Check that all LEDs go out, then press and hold the  button for at least two seconds.
- (5) Check that the Error LED is lit and close the top cover.
- (6) Double-click "BrUsbsn.exe" that was copied into the temporary folder to start it. The "BrUsbSn" window shown on the right appears.
- (7) In the "Product Category" field, select "2 Mono-Laser".
- (8) Select "2013_Printer".
- (9) In the "Port" field, select the port number assigned to the "Brother Maintenance USB Printer".
If the port number is unknown, follow the steps below to check it.
 - 1) Click "Start", "Settings", and "Printers and Faxes". The "Printers and Faxes" window appears.
 - 2) Right-click the "Brother Maintenance USB Printer" icon.
 - 3) Click "Properties". The Brother Maintenance USB Printer Properties window appears.
 - 4) Click the "Ports" tab. The Brother Maintenance USB Printer port number is displayed.
- (10) Enter the last five digits on the laser serial number label in the "Scanner Video Cik" field.

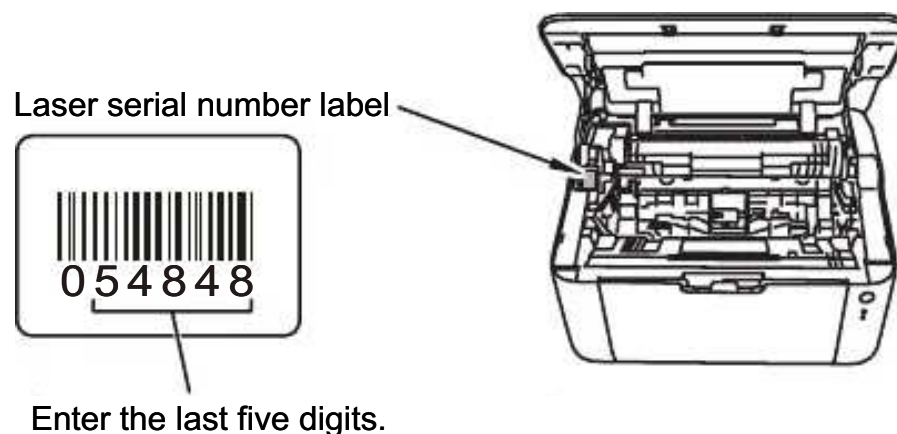
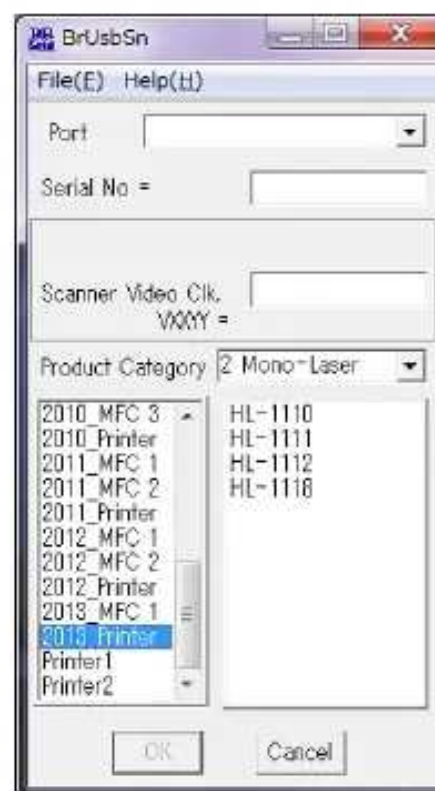

Fig. 3-2

- (11) Click the [OK] button, then the confirmation screen appears. Check that the serial number and the adjusted value of the laser unit are correct and click the [Yes] button. The adjusted value of the laser unit is written to the machine.
- (12) Turn OFF the power switch of the machine.

3. IF YOU REPLACE THE LOW VOLTAGE POWER SUPPLY PCB UNIT

<What to do after replacement>

- Resetting irregular power supply detection counter



■ What you need to prepare

- (1) One USB cable
- (2) Create a temporary folder on the C drive of the computer (Windows® XP or later).
- (3) Download utility (FILEDG32.EXE)
Copy this file into the temporary folder created on the C drive.
- (4) Maintenance driver (MaintenanceDriver.zip)
When the maintenance driver is not installed on the computer, copy this file into the temporary folder created on the C drive, and extract the copied file.
- (5) Irregular power supply detection counter PJL file (SQWAVE.PJL)

3.1 Resetting Irregular Power Supply Detection Counter

The irregular power supply detection counter increases by one when the machine detects irregular power supply.

When the counter reaches the limit and the irregular power supply detection error is displayed, replace the low voltage power supply PCB unit, which may have been damaged by repeated irregular power supply, and reset the irregular power supply detection counter. In this case, if the same power supply is used, the same error may occur even when the low voltage power supply PCB unit is replaced. Ask the user to review the installation environment to avoid the same error occurring again.

- (1) Turn OFF the power switch of the machine.
- (2) Connect the machine to your computer using the USB cable.
- (3) Check that the power switch is turned OFF. Press and hold the  button and check that the Ready and Error LEDs are lit. Then open the top cover and check that the Error LED goes out and only the Ready LED is lit. Take out the drum unit and check that the Error LED is lit. Check that the Ready and Error LEDs are lit and release the  button.
- (4) Check that all LEDs go out, then press and hold the  button for at least two seconds.
- (5) Check that the Error LED is lit and close the top cover.
- (6) Double-click "FILEDG32.EXE" on the PC to start it, and select "Brother Maintenance USB Printer".
- (7) Drag and drop the "SQWAVE.PJL" onto the "Brother Maintenance USB Printer" icon.
- (8) Turn OFF the power switch of the machine.

CHAPTER 4 SERVICE FUNCTIONS

1. PRINTING PRINTER SETTINGS

Printer Settings can be printed.

<Operating Procedure>

- (1) Press the  button three times while the machine is in the ready state. Printing starts.
- (2) When printing is completed, the machine returns to the ready state.

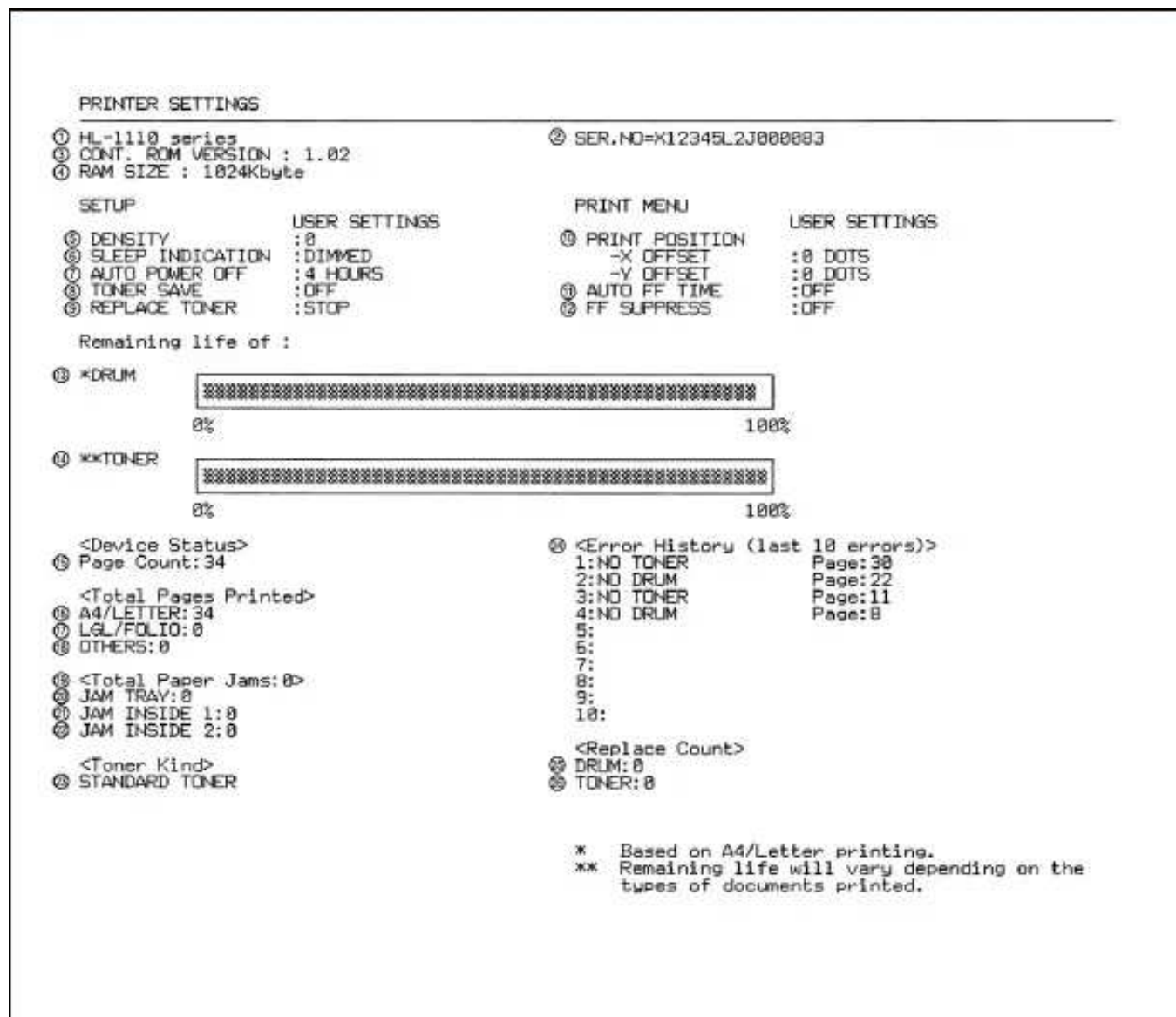



Fig. 4-1

1	Model	14	Estimated remaining toner amount
2	Serial number	15	Total printed pages
3	Main firmware version	16	Paper input for A4 and Letter
4	RAM size	17	Paper input for Legal and Folio
5	Printing density	18	Paper input for other than A4, Letter, Legal, and Folio
6	LED display in sleep mode	19	Total paper jams
7	Auto power OFF	20	Paper jams that have occurred in the paper tray
8	Toner save mode	21	Paper jams that have occurred in the machine
9	Stop mode / Continue mode (Toner Replacement)	22	Paper jams that have occurred in the ejecting section
10	Print position off-set	23	Current toner type
11	Timeout setting for Auto formfeed	24	Machine error history
12	Formfeed suppress status	25	The number of times that the drum unit has been replaced
13	Remaining life of drum unit	26	The number of times that the toner cartridge has been replaced

2. RESETTING DRUM COUNTER

By following this procedure after the drum unit has been replaced, the warning that appeared when the drum unit was expiring or when it had reached the limit will be deactivated.

<Operating Procedure>

- (1) Open the top cover while the machine is in the ready state. Press the  button four times to reset the drum counter.

3. SWITCHING BETWEEN CONTINUE MODE AND STOP MODE

This function is to change the toner setting to continuous printing mode (allows you to use the current toner cartridge even when the LED is prompting toner replacement) or stop mode (default).



<Operating Procedure>

- (1) Press the  button seven times while the machine is in the ready state.
All LEDs flash twice when continue mode is set (ON 1 sec. / OFF 1 sec.)
All LEDs flash once when toner stop mode is set (ON 1 sec.)

4. TEST PRINTING

This function is to print a test page.

<Operating Procedure>

- (1) Check that the power switch is turned OFF. Press and hold the  button and check that the Ready and Error LEDs are lit. Then open the top cover and check that the Error LED goes out and only the Ready LED is lit. Close the top cover and press the  button.
- (2) Press the  button once to start the test printing.

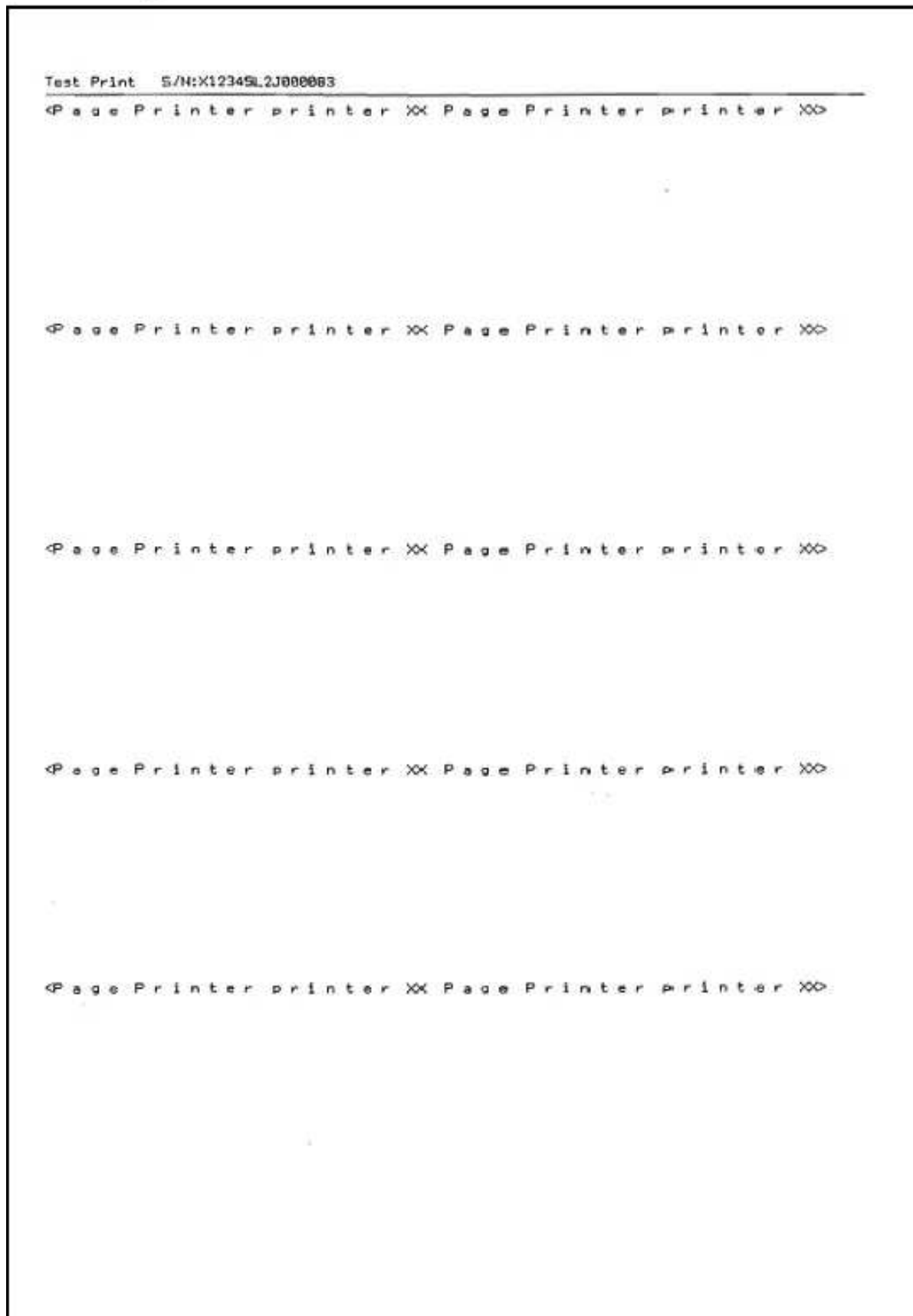





Fig. 4-2

5. MAINTENANCE PRINTING

This function is to print a list of maintenance information including printer coverage information.

<Operating Procedure>

- (1) Check that the power switch is turned OFF. Press and hold the  button and check that the Ready and Error LEDs are lit. Then open the top cover and check that the Error LED goes out and only the Ready LED is lit.
- (2) Take out the drum unit and check that the Error LED is lit. Check that the Ready and Error LEDs are lit and release the  button. Check that all LEDs go out.
- (3) Set the drum unit and close the top cover.
- (4) Press the  button twice. Check that the Error LED is lit.
- (5) Press the  button once to start the maintenance printing.

```

<<PRINT MAINTENANCE>>
① Brother HL-1110 series
② Serial Number: X12345H2J000124
③ CONT. ROM VERSION: 0.44
④ ENGINE VERSION: 0.42

<Device Status>
⑤ Page Count: 20112
⑥ Drum Count(Page Count/Round Count): 20112/4159
⑦ *** Average Coverage(Total): 0.02%
⑧ *** Average Coverage(Current): 1.36%
⑨ *** Average Coverage(Previously Used Toner): 0%

<<Drum Information>>
⑩ Estimated Pages Remaining: 0
  (% of Life Remaining: 0%)

<Total Pages Printed>
⑪ Previously Used Toner: 2
⑫ Current Toner: 60
  **(% of Life Remaining: 98%)

<Total Pages Printed>
⑬ A4/Letter: 150
⑭ Legal/Folio: 1
⑮ Others: 0

<Total Paper Jams: 1>
⑯ JAM Tray: 0
⑰ JAM Inside 1: 1
⑱ JAM Inside 2: 0

⑲ <Error History (last 10 errors)>
  1: JAM INSIDE 1      Page: 20104
  2: CARTRIDGE ERROR Page: 20052
  3: NO DRUM          Page: 20052
  4: NO TONER         Page: 20007
  5: NO DRUM          Page: 20006
  6: DRUM ERROR       Page: 39
  7: CARTRIDGE ERROR Page: 39
  8: DRUM ERROR       Page: 39
  9: CARTRIDGE ERROR Page: 39
 10: WRONG PAPER TYPE Page: 38

<Replace Count>
⑳ Drum: 0
㉑ Toner: 6(0)

㉒ <Current Developing Roller Count(Total/Print): 400/352>
㉓ <Previous Developing Roller Count(Total/Print): 44/19>
㉔ <Developing Bias: 324 V>

㉕ <Power On Time: 176hours>
㉖ <Power On Count: 52>

㉗ <Engine Sensor Log>
  KD: 000000/000000
  RS: 000000/000000 EJ: 000000/000000

㉘ <Status Log>
  001101 001101 001101 003002 001101
  002304 001101 002500 002500 001101

㉙ <First Date PC-Prn: 2013/01/11>
  [02] [00] [00] [00] [00] (0X) (ASS 00) [101] [087d]
  ① ② ③ ④ ⑤ ⑥ ⑦ ⑧ ⑨ ⑩

*Based on A4/Letter printing.
**Remaining life will vary depending on the types of documents printed.
***Calculated coverage.

```

Fig. 4-3

1	Model name	21	The number of times that the toner cartridge has been replaced
2	Serial number	22	Rotations of the developer roller of currently set toner cartridge
3	Machine ROM version	23	Rotations of the developer roller of previously set toner cartridge
4	Engine archive version	24	Current developing bias voltage value
5	Total printed pages	25	Total power distribution time
6	Drum count page / rotations of the drum	26	The number of times that the power has been turned ON
7	Accumulated average coverage	27	Sensor operating state* ¹
8	Average coverage by the toner cartridge which is currently used	28	Engine error log
9	Average coverage by the toner cartridge which is previously used	29	Start date for machine operation
10	Total printed pages at corresponding value of drum (Remaining life of drum)	30	The number of times of the discharge error
11	Total printed pages of previously set toner cartridge	31	The number of times of the fuser unit error
12	Total printed pages of currently set toner cartridge (Remaining life of toner cartridge)	32	Polygon motor error occurred
13	Total input papers of A4 size / Letter size	33	The number of times of the irregular power supply detection error
14	Total input papers of Legal size / Folio size	34	Not necessary for maintenance
15	Total input papers other than A4 size / Letter size / Legal size / Folio size	35	Result of Main PCB / High-voltage PCB inspection
16	Paper jams that have occurred in tray	36	Paper size / Toner type of currently set toner cartridge / Toner type of previously set toner cartridge
17	Paper jams that have occurred inside the machine	37	PCB information / Areas
18	Paper jams that have occurred in the paper eject path	38	Country code
19	Machine error log	39	NVRAM check sum
20	The number of times that the drum unit has been replaced		

*¹ KO : Paper feed sensor OFF time / Paper feed sensor ON time





RS : Paper printing position sensor OFF time / Paper printing position sensor ON time

EJ : Eject sensor OFF time / Eject sensor ON time

6. RESETTING TONER MANUALLY

This function allows you to manually perform the same operation as when the toner cartridge is replaced with a new one. This function provides a method to deactivate the following errors: when a new toner cartridge cannot be detected, and the toner life cannot be reset.

<Operating Procedure>

- (1) Check that the power switch is turned OFF. Press and hold the  button and check that the Ready and Error LEDs are lit. Then open the top cover and check that the Error LED goes out and only the Ready LED is lit.
- (2) Take out the drum unit and check that the Error LED is lit. Check that the Ready and Error LEDs are lit and release the  button. Check that all LEDs go out.
- (3) Set the drum unit and close the top cover.
- (4) Press the  button twice. Check that the Error LED is lit.
- (5) Reset the counter by:
Pressing the  button five times for the starter toner.
Pressing the  button six times for the standard toner.

APPENDIX 1 SERIAL NUMBERING SYSTEM

■ Serial number label (1 location)

<How to Read>

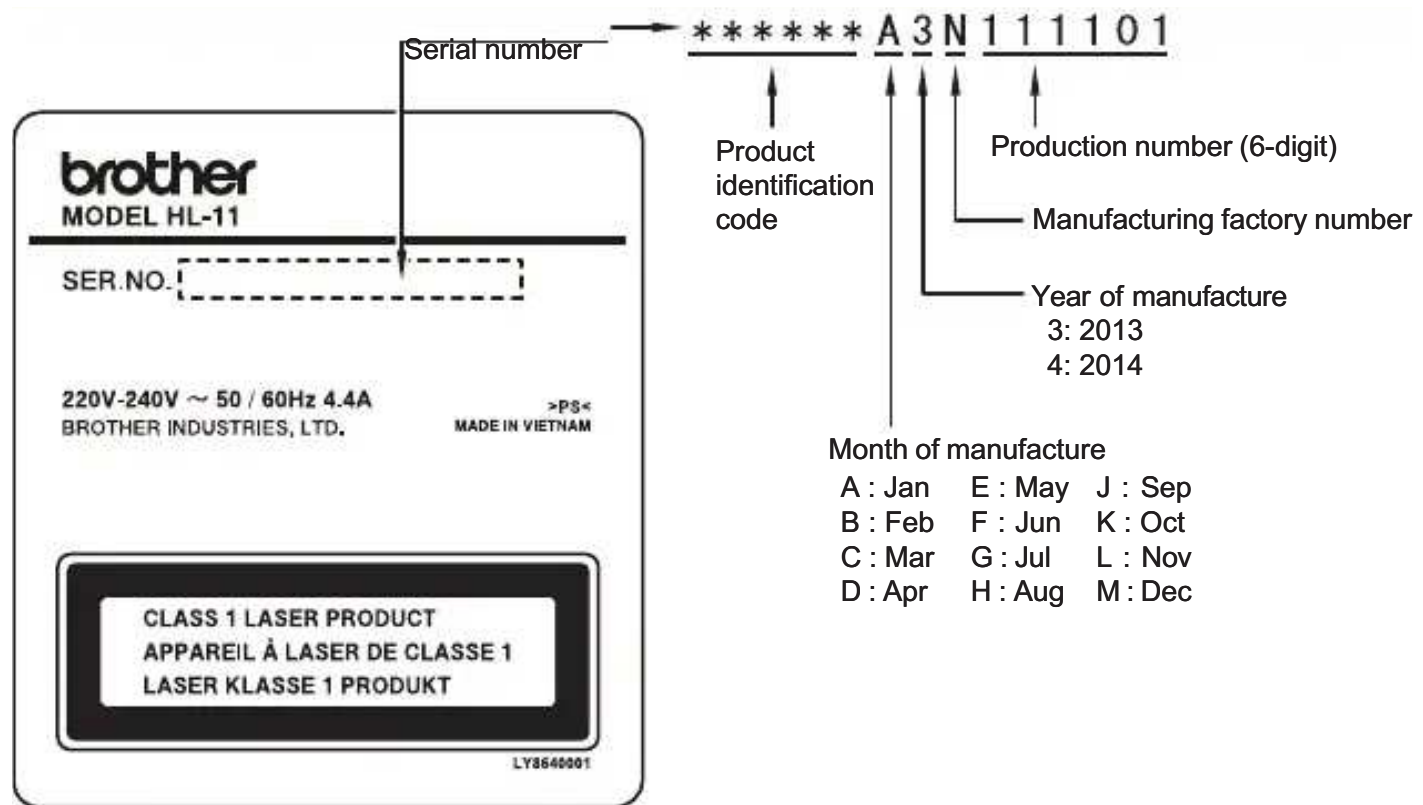

Fig. App. 1-1

<Location>

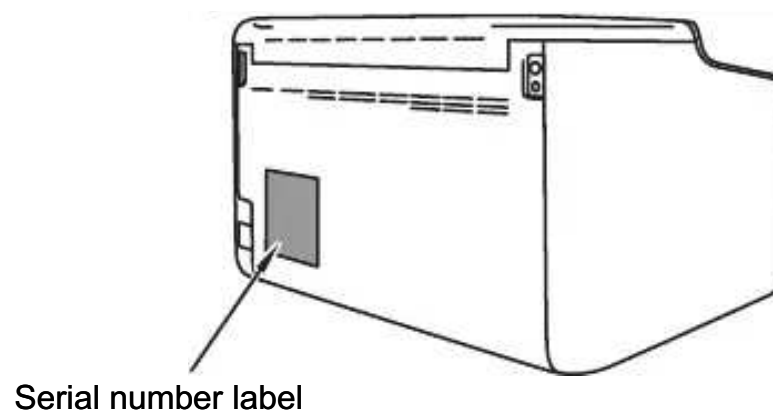





Fig. App. 1-2

APPENDIX 2 DELETING USER SETTING INFORMATION

The user setting information for the machine is stored in the main PCB. You can return this to the default settings by following the procedure below.

<Operating Procedure>

- (1) Check that the power switch is turned OFF. While pressing and holding the  button, check that all LEDs light. Then open and close the top cover. Release the  button, and check that all LEDs go out.
- (2) Press the  button ten times.
- (3) When completed, the machine returns to the ready state automatically.

