

Brother Laser MFC
SERVICE MANUAL

MODEL

**DCP-L5500D/L5500DN/L5502DN/L5600DN
DCP-L5602DN/L5650DN/L5652DN/L6600DW
MFC-8530DN/8535DN/8540DN
MFC-L5700DN/L5700DW/L5702DW/L5750DW
MFC-L5755DW/L5800DW/L5802DW/5850DW
MFC-L5900DW/L5902DW/L6700DW/L6702DW
MFC-L6750DW/L6800DW/L6900DW/L6902DW**

OPTION

**LT: Lower Tray LT-5500/5505/6500/6505
TT: Tower Tray TT-4000**

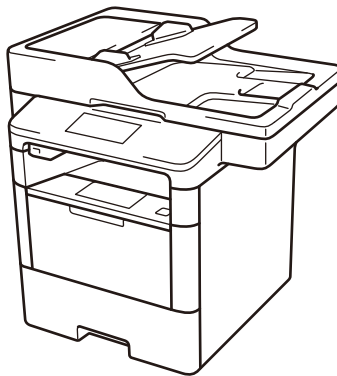

Read this manual thoroughly before maintenance work.
Keep this manual in a convenient place for quick and easy reference at all times.

Trademarks

BROTHER is either a trademark or a registered trademark of Brother Industries, Ltd.

Microsoft, Windows, Windows Vista, Windows Server, SharePoint, Internet Explorer, Outlook, PowerPoint and Windows phone are either registered trademarks or trademarks of Microsoft Corporation in the United States and/or other countries.

Apple, Macintosh, Mac OS, iPad, iPhone, iOS, iPod touch and OS X are trademarks of Apple Inc., registered in the United States and other countries.

AirPrint and the AirPrint logo are trademarks of Apple Inc.

Nuance and PaperPort are trademarks or registered trademarks of Nuance Communications, Inc. or its affiliates in the United States and/or other countries.

Adobe, PostScript and PostScript 3 are either registered trademarks or trademarks of Adobe Systems Incorporated in the United States and/or other countries.

Wi-Fi, Wi-Fi Alliance, Wi-Fi Direct and Wi-Fi Protected Access are registered trademarks of Wi-Fi Alliance®.

WPA, WPA2, Wi-Fi Protected Setup and Wi-Fi Protected Setup logo are trademarks of Wi-Fi Alliance®.

Flickr and the Flickr logo are the trademarks and/or registered trademarks of Yahoo! Inc.

Android, Google Cloud Print, Google Drive, Google Chrome, Picasa Web Albums and Google Play are trademarks of Google, Inc. Use of these trademarks are subject to Google Permissions.

Mozilla and Firefox are registered trademarks of the Mozilla Foundation.

UNIX is a registered trademark of The Open Group in the United States and other countries.

Linux is the registered trademark of Linus Torvalds in the U.S. and other countries.

Intel is a trademark of Intel Corporation in the U.S. and/or other countries.

Evernote and the Evernote Elephant logo are trademarks of Evernote Corporation and used under a license.

Each company whose software title is mentioned in this manual has a Software License Agreement specific to its proprietary programs.

Any trade names and product names of companies appearing on Brother products, related documents and any other materials are all trademarks or registered trademarks of those respective companies.

Open Source Licensing Remarks

This product includes open-source software.

Please visit the Brother Solutions Center at <http://support.brother.com> to view the Open Source Licensing Remarks and Copyright information.

Copyright and License

©2015 Brother Industries, Ltd. All rights reserved.

This product includes software developed by the following vendors:

©1983-1998 PACIFIC SOFTWARES, INC. ALL RIGHTS RESERVED.

©2008 Devicescape Software, Inc. All rights reserved.

This product includes the "KASAGO TCP/IP" software developed by ZUKEN ELMIC, Inc.

Other Information

FlashFX[®] is a registered trademark of Datalight, Inc.

FlashFX[®] Copyright 1998-2014 Datalight, Inc.

U.S. Patent Office 5,860,082/6,260,156

FlashFX[®] Pro[™] is a trademark of Datalight, Inc.

FlashFX[®] Tera[™] is a trademark of Datalight, Inc.

Reliance[™] is a trademark of Datalight, Inc.

Reliance Nitro[™] is a trademark of Datalight, Inc.

Datalight[®] is a registered trademark of Datalight, Inc.

Copyright 1989-2014 Datalight, Inc., All Rights Reserved

CONTENTS

SAFETY INFORMATION

CHAPTER 1 SUPPLEMENTAL SPECIFICATIONS

1. GENERAL	1-1
2. NETWORK CONNECTIVITY	1-9
3. SERVICE INFORMATION	1-10
4. SUPPLIES	1-12
5. MEDIA SPECIFICATIONS	1-15
6. FAX (ONLY FOR THE MODELS WITH FAX FUNCTION)	1-15
7. COPY	1-16
8. SCANNER	1-17

CHAPTER 2 ERROR INDICATIONS & TROUBLESHOOTING

1. INTRODUCTION	2-1
1.1 Precautions	2-1
1.2 Checks before Commencing Troubleshooting	2-2
2. OVERVIEW	2-4
2.1 Cross-section Drawing	2-4
2.1.1 Printer part	2-4
2.1.2 Scanner part	2-5
2.2 Paper Feeding	2-6
2.2.1 Printer part	2-6
2.2.2 Scanner part	2-7
2.3 Operation of Each Part	2-8
2.4 Block Diagram	2-10
2.5 Main Components	2-11
3. ERROR INDICATIONS	2-12
3.1 Error Codes	2-12
3.2 Error Messages	2-22
3.3 Communication Errors	2-34
4. TROUBLESHOOTING	2-38
4.1 Error Cause and Remedy	2-38
4.2 Troubleshooting for Paper Feeding Problems	2-82
4.2.1 No paper is fed from machine paper tray	2-82
4.2.2 No paper is fed from LT	2-83
4.2.3 No paper is fed from TT	2-84

4.2.4	No paper is fed from MP tray	2-85
4.2.5	Multiple sheets of paper are fed	2-86
4.2.6	Paper becomes wrinkled	2-86
4.2.7	Paper is fed at an angle	2-87
4.2.8	Paper is curled	2-88
4.2.9	Duplex printing is not possible	2-88
4.2.10	Paper jam	2-89
4.3	Troubleshooting for Image Defects	2-95
4.3.1	Image defect examples	2-95
4.3.2	Troubleshooting according to image defect	2-96
4.4	Troubleshooting for Software Problems	2-108
4.4.1	Cannot receive data	2-108
4.5	Troubleshooting for Network Problems	2-109
4.5.1	Cannot print via network connection	2-109
4.5.2	Cannot connect to access point	2-109
4.6	Troubleshooting for Control Panel Problems	2-109
4.6.1	Nothing is displayed on the LCD	2-109
4.6.2	Nothing is displayed on the LED	2-110
4.6.3	Control panel is inoperable	2-110
4.7	Troubleshooting for Toner and Drum Problems	2-111
4.7.1	New toner is not detected	2-111
4.7.2	Toner cartridge cannot be recognized	2-111
4.7.3	Error message prompting toner cartridge replacement does not disappear	2-111
4.7.4	Drum error	2-112
4.7.5	Error message prompting drum replacement does not disappear	2-112
4.8	Troubleshooting for Fuser Unit Problems	2-113
4.8.1	Fuser unit failure	2-113
4.9	Troubleshooting for Laser Unit Problems	2-113
4.9.1	Laser unit failure	2-113
4.10	Troubleshooting for PCB Problems	2-114
4.10.1	Main PCB failure	2-114
4.10.2	Memory full	2-114
4.11	Troubleshooting for Document Feeding Problems	2-115
4.11.1	No document is fed	2-115
4.11.2	Multiple documents are fed	2-115
4.11.3	Document jam	2-115
4.11.4	Document becomes wrinkled	2-116
4.11.5	Document size is not detected correctly	2-117
4.12	Troubleshooting for Image Defects	2-118
4.12.1	Defect examples	2-118
4.12.2	Troubleshooting according to image defect	2-118
4.13	Troubleshooting for Fax Problems	2-122
4.13.1	Fax cannot be sent	2-122
4.13.2	Fax cannot be received	2-123

4.13.3	Communication error occurs	2-123
4.14	Troubleshooting for Other Problems	2-124
4.14.1	Cannot print	2-124
4.14.2	Cannot update firmware	2-124
4.14.3	USB direct interface errors	2-124
4.14.4	"Paper Low" message does not disappear	2-125

CHAPTER 3 DISASSEMBLY/REASSEMBLY

1.	SAFETY PRECAUTIONS	3-1
2.	PACKING	3-2
3.	SCREW CATALOGUE	3-3
4.	SCREW TORQUE LIST	3-4
5.	LUBRICATION	3-7
6.	OVERVIEW OF GEARS	3-9
7.	HARNESS ROUTING	3-11
8.	DISASSEMBLY FLOW CHART	3-24
8.1	Machine	3-24
8.2	LT	3-26
9.	DISASSEMBLY PROCEDURE	3-27
9.1	Preparation	3-27
9.2	Paper tray	3-28
9.3	Back cover / Outer chute	3-30
9.4	Fuser cover	3-31
9.5	Fuser unit	3-32
9.6	MP cover ASSY	3-35
9.7	Front cover ASSY	3-37
9.8	Side cover L	3-38
9.9	Side cover R	3-39
9.10	ADF/document scanner unit	3-40
9.11	ADF unit	3-43
9.11.1	ADF unit	3-43
9.11.2	Hinge L ASSY, Hinge R, Hinge R support, Hinge arm R	3-45
9.11.3	ADF cover ASSY, Document stopper	3-46
9.11.4	Gear cover, ADF front cover, Document sub tray	3-47
9.11.5	Document separate roller ASSY	3-49
9.11.6	ADF separation holder ASSY	3-50
9.11.7	Second side CIS unit, Second side CIS flat cable (Models with duplex printing only)	3-51
9.12	Panel unit	3-56
9.12.1	Panel unit	3-56

9.12.2	Panel PCB ASSY, LCD (For LCD: 4.85 inch models)	3-58
9.12.3	Panel PCB ASSY, LCD, LCD relay PCB ASSY, LCD relay flat cable (For LCD: 3.7 inch models)	3-60
9.12.4	Touch panel ASSY	3-62
9.12.5	NFC PCB ASSY (Models with NFC only)	3-63
9.13	USB host PCB ASSY	3-64
9.14	First side CIS unit, First side CIS flat cable	3-65
9.15	Joint cover ASSY	3-72
9.16	Modem PCB ASSY (Models with FAX only)	3-74
9.17	Stack sensor PCB ASSY (Models with USB host on the rear side only)	3-76
9.18	Main PCB ASSY / Wireless LAN PCB (Wireless LAN models only)	3-77
9.19	External temperature/humidity sensor	3-79
9.20	Laser unit	3-80
9.21	PF roller holder ASSY	3-82
9.22	Low-voltage power supply PCB ASSY	3-83
9.23	Toner amount detection sensor PCB ASSY (light emission)	3-86
9.24	Main fan	3-88
9.25	Filter	3-90
9.26	Relay front PCB ASSY	3-91
9.27	Registration clutch / T1 pickup clutch	3-92
9.28	Main frame L ASSY	3-93
9.29	Paper feed motor	3-96
9.30	Develop joint gear 37 / Develop joint	3-98
9.31	Toner amount detection sensor PCB ASSY (light reception)	3-99
9.32	MP solenoid	3-100
9.33	Develop clutch 51R	3-101
9.34	Internal temperature sensor	3-102
9.35	Fuser drive gear 39	3-103
9.36	Eject motor	3-105
9.37	Back cover/duplex tray sensor	3-106
9.38	LT/TT connector	3-107
9.39	High-voltage power supply PCB ASSY	3-108
9.40	Eject sensor PCB ASSY	3-111
9.41	MP roller holder ASSY / MP separation pad ASSY / MP separation pad spring	3-112
9.42	T1 paper feed sensor PCB ASSY / T1 paper feed actuator / T1 paper feed actuator spring	3-113
9.43	MP paper empty sensor PCB ASSY / MP paper empty actuator 1 / MP paper empty actuator 2	3-115
9.44	Paper empty sensor PCB ASSY (Models with USB host on the rear side only)	3-118
9.45	Registration front/rear sensor PCB ASSY	3-119
10.	DISASSEMBLY PROCEDURE (LT UNIT)	3-122
10.1	Paper tray	3-122
10.2	LT roller holder ASSY	3-124

10.3	LT side cover L	3-125
10.4	LT side cover R	3-126
10.5	LT front cover ASSY	3-127
10.6	LT control PCB ASSY	3-128
10.7	LT pickup clutch	3-129
10.8	LT release clutch	3-130
10.9	LT connector ASSY / LT connector upper	3-133
10.10	LT paper feed sensor PCB ASSY	3-134
10.11	LT paper empty sensor PCB ASSY	3-137

CHAPTER 4 ADJUSTING AND UPDATING SETTINGS AS REQUIRED AFTER PARTS REPLACEMENT

1.	IF YOU REPLACE THE MAIN PCB ASSY	4-1
1.1	Installing Firmware (Sub Firmware and Main Firmware)	4-2
1.1.1	Checking firmware version	4-2
1.1.2	Installing firmware	4-3
1.2	Adjusting Touch Panel (Function Code: 61)	4-5
1.3	Initializing the EEPROM of the Main PCB ASSY (Function Code: 01)	4-5
1.4	Configure for Country/Region and Model (Function Code: 74)	4-5
1.5	Activating Memory Writing	4-5
1.6	Setting Serial Number and Entering Adjusted Value of Laser Unit	4-6
1.7	Acquiring White Level Data (Function Code: 55)	4-7
1.8	Adjusting Left-end and Upper-end Print Position (Function Code: 45) (TT only)	4-7
1.9	Resetting to Factory Shipping State	4-7
2.	IF YOU REPLACE THE LOW-VOLTAGE POWER SUPPLY PCB ASSY	4-8
2.1	Resetting Irregular Power Supply Counter of the Low-voltage Power Supply PCB (Function Code: 88)	4-8
3.	IF YOU REPLACE THE LASER UNIT	4-9
3.1	Entering Adjusted Value of Laser Unit	4-10
3.2	Resetting Printed Pages Counter of the Laser Unit	4-10
4.	IF YOU REPLACE THE LCD PANEL ASSY OR PANEL PCB	4-11
4.1	Adjusting Touch Panel (Function Code: 61)	4-11
4.2	Checking LCD Operation (Function Code: 12)	4-11
5.	IF YOU REPLACE THE ADF UNIT, FIRST SIDE CIS UNIT, SECOND SIDE CIS UNIT OR DOCUMENT SCANNER UNIT	4-12
5.1	Acquiring White Level Data (Function Code: 55)	4-12
5.2	Scanning and Printing Check	4-12
6.	IF YOU REPLACE THE FUSER UNIT	4-13
6.1	Resetting Printed Pages Counter of the Fuser Unit	4-13
7.	IF YOU REPLACE A PF KIT	4-14
7.1	Resetting Printed Pages Counter of a PF Kit	4-14

8. IF YOU REPLACE THE TT / LT	4-15
8.1 Installing Firmware (Main Firmware)	4-16
8.1.1 Checking firmware version	4-16
8.1.2 Installing firmware	4-17
8.2 Adjusting Left-end and Upper-end Print Position (TT only)	4-18

CHAPTER 5 SERVICE FUNCTIONS

1. MAINTENANCE MODE	5-1
1.1 How to Enter Maintenance Mode	5-1
1.1.1 Method of entering maintenance mode for service personnel	5-1
1.1.2 Method of entering end-user accessible maintenance mode	5-2
1.2 List of Maintenance Mode Functions	5-3
1.3 Details of Maintenance Mode Functions	5-5
1.3.1 Initialize EEPROM parameters (function code: 01, 91)	5-5
1.3.2 ADF performance test (function code: 08)	5-6
1.3.3 Print quality test pattern (function code: 09)	5-7
1.3.4 Set worker switches (WSW) and print worker switch setting data (function code: 10, 11)	5-8
1.3.5 Check LCD operation (function code: 12)	5-11
1.3.6 Check control panel key operation (function code: 13)	5-12
1.3.7 Save NetConfig data (function code: 18)	5-13
1.3.8 Display software version (function code: 25)	5-14
1.3.9 Change OnePushDemo function setting (function code: 28)	5-15
1.3.10 Check sensor operation (function code: 32)	5-16
1.3.11 Display LAN connection status (function code: 33)	5-20
1.3.12 Set PC print functions (function code: 43)	5-21
1.3.13 Change USB No. return value / Adjust left-end print position / Adjust upper-end print position / Set HEXDUMP Mode (function code: 45)	5-24
1.3.14 Adjust printable range for each speed level (Full speed / Half speed for thick paper / Quiet Mode) (function code: 46)	5-27
1.3.15 Set country / language (function code: 52)	5-29
1.3.16 Transfer received fax data / log information (function code: 53) (fax models only)	5-30
1.3.17 Fine-tune scanning position (function code: 54)	5-32
1.3.18 Acquire white level data and set CIS scan area (function code: 55)	5-33
1.3.19 Adjust touch panel (function code: 61)	5-34
1.3.20 Continuous print test (function code: 67)	5-35
1.3.21 Print frame pattern (single-side printing) (function code: 69)	5-39
1.3.22 Print frame pattern (duplex printing) (function code: 70)	5-40
1.3.23 Print test pattern (function code: 71)	5-41
1.3.24 Configure for country/region and model (function code: 74)	5-44
1.3.25 Print maintenance information (function code: 77)	5-49
1.3.26 Check main fan operation (function code: 78)	5-51
1.3.27 Delete fax data (function code: 79)	5-52
1.3.28 Display machine log information (function code: 80)	5-53
1.3.29 Display machine error code (function code: 82)	5-57

1.3.30	Send communication log information to telephone line (function code: 87)	5-58
1.3.31	Reset counters for consumable parts (function code: 88)	5-59
1.3.32	Quit maintenance mode (function code: 99)	5-60
2.	OTHER SERVICE FUNCTIONS	5-61
2.1	Print Communication Error List	5-61
2.2	Reset the Drum Unit Counter	5-61

CHAPTER 6 WIRING DIAGRAM

1.	WIRING DIAGRAM	6-1
-----------	-----------------------	------------

CHAPTER 7 PERIODICAL MAINTENANCE

1.	SAFETY PRECAUTIONS	7-1
2.	PERIODICAL REPLACEMENT PARTS	7-2
2.1	Preparation	7-2
2.2	Fuser unit	7-3
2.3	Laser unit	7-7
2.4	PF kit MP	7-17
2.5	PF kit 1	7-18
2.6	PF kit 2/3/4/5	7-20

APPENDIX 1 SERIAL NUMBERING SYSTEM

APPENDIX 2 DELETING USER SETTING INFORMATION

APPENDIX 3 INSTALLING THE MAINTENANCE PRINTER DRIVER

SAFETY INFORMATION

■ Definitions of Warnings, Cautions and Notes

The following conventions are used in this manual:

WARNING

WARNING indicates a potentially hazardous situation which, if not avoided, could result in death or serious injuries.

CAUTION

CAUTION indicates a potentially hazardous situation which, if not avoided, may result in minor or moderate injuries.

IMPORTANT

IMPORTANT indicates a potentially hazardous situation which, if not avoided, may result in damage to property or loss of product functionality.

 Prohibition icons indicate actions that must not be performed.

 Electrical Hazard icons alert you to possible electrical shocks.

 Fire hazard icons alert you to the possibility of a fire.

 Hot Surface icons warn you not to touch product parts that are hot.

Note Notes tell you how you should respond to a situation that may arise or give tips about how the operation works with other features.

■ To use the Machine Safely

Please keep these instructions for later reference and read them before attempting any maintenance. If you do not follow these safety instructions, there is a possibility of a fire, electrical shock, burn or suffocation.

WARNING

ELECTRICAL HAZARDS

Failure to follow the warnings in this section may create the risk of an electrical shock. In addition, you could create an electrical short, which may create the risk of a fire.



There are high voltage electrodes inside the product. Before you access the inside of the product, including for routine maintenance such as cleaning, make sure you have unplugged the telephone line cord first (MFC only) and then the power cord from the AC power outlet, as well as any telephone (RJ-11) (MFC only) or Ethernet (RJ-45) cables (Network models only) from the product. Never push objects of any kind into this product through cabinet slots, since they may touch dangerous voltage points or short out parts.

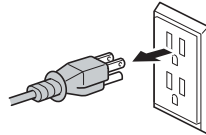

Unplug the power plug regularly to clean it. Use a dry cloth to clean the root of the plug blades and between the blades. If the power plug is plugged into the outlet over a long period, dust accumulates around the plug blades, which may cause a short circuit resulting in a fire.



DO NOT handle the plug with wet hands. Doing this might cause an electrical shock.

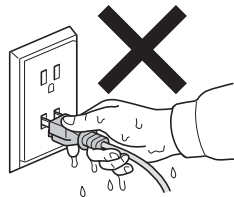

Always make sure the plug is fully inserted. DO NOT use the product or handle the cord if the cord has become worn or frayed.



DO NOT allow this product to come into contact with water.



This product should be connected to an AC power source within the range indicated on the rating label. DO NOT connect it to a DC power source or inverter.



Power Cord Safety:

- This product is equipped with a 3-wire grounded plug. This plug will only fit into a grounded power outlet. This is a safety feature. If you are unable to insert the plug into the outlet, call your electrician to replace your obsolete outlet. **DO NOT** attempt to defeat the purpose of the grounded plug.
- Only use the power cord supplied with this product.
- This product should be positioned so that nothing pinches or constricts the power cord.
- **DO NOT** allow anything to rest on the power cord.
- **DO NOT** place this product where people may step on the cord.
- **DO NOT** place this product in a position where the cord is stretched or strained, as it may become worn or frayed.
- Brother strongly recommends that you **DO NOT** use any type of extension cord.



DO NOT use this product during an electrical storm.



(MFC only)

Use caution when installing or modifying telephone lines. Never touch telephone wires or terminals that are not insulated unless the telephone line has been unplugged from the wall jack.

Never install telephone wiring during a lightning storm. Never install a telephone wall jack in a location that is wet or may become wet, for example, near a refrigerator or other appliance that produces condensation.



DO NOT put a toner cartridge, a toner cartridge and drum unit assembly, or waste toner box into a fire. It could explode, resulting in injuries.



DO NOT use flammable substances, any type of spray, or an organic solvent/liquid containing alcohol or ammonia to clean the inside or outside of the product. Doing so could cause a fire or electrical shock. Instead, use only a dry, lint-free cloth.

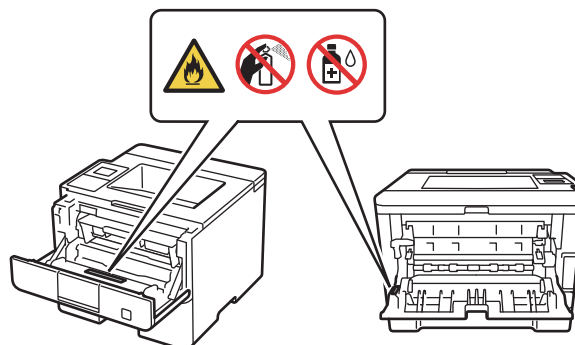

DO NOT attempt to operate this product when a paper jam or stray pieces of paper are inside the product. Prolonged contact of the paper with the fuser unit could cause a fire.



DO NOT use a vacuum cleaner to clean up scattered toner. Doing this might cause the toner dust to ignite inside the vacuum cleaner, potentially starting a fire. Please carefully clean the toner dust with a dry, lint-free soft cloth and dispose of it according to local regulations.



Unplug this product from the wall socket before cleaning the product and the scanner glass. DO NOT use liquid or aerosol cleaners. Use a dry, lint-free soft cloth for cleaning.



DO NOT place the following objects on the product. If these objects contact the electrical parts inside the product, it may cause a fire or electric shock.

- Metal object such as a clip or a staple
- Precious metal such as a necklace or a ring
- Container holding water or liquid such as a glass, a flower vase or a flower pot



HOT SURFACE

After you have just used the product, some internal parts of the product will be extremely hot. Wait at least 10 minutes for the product to cool down before you touch the internal parts of the product.

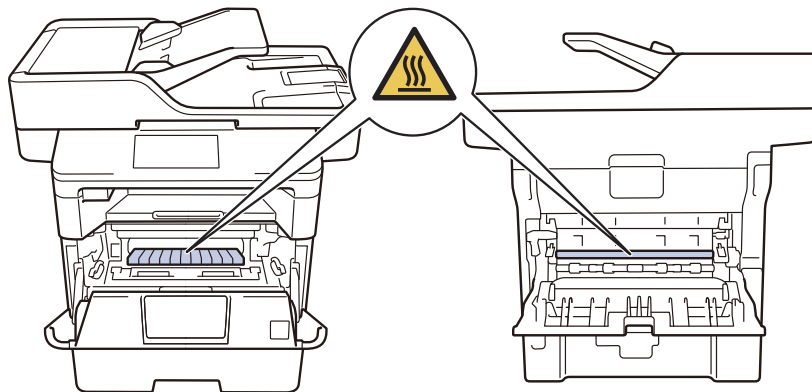

If you use a Lower Tray, DO NOT carry the product with the Lower Tray as you may be injured or cause damage to the product because it is not attached to the Lower Tray.



CAUTION

This product is heavy and weighs more than 35.9 lb. (16.3 kg) including paper. To prevent possible injuries at least two people should lift the product by holding it from the front and back.

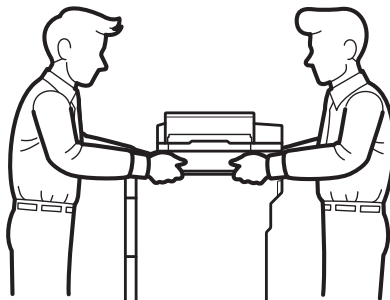

To prevent injuries, be careful not to put your fingers in the areas shown in the illustrations.

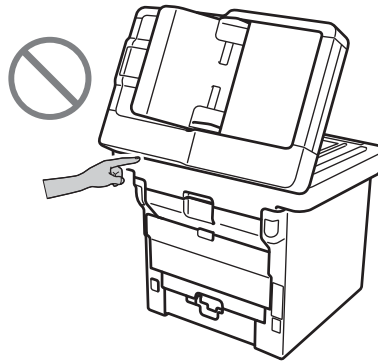

(MFC only)

Never touch exposed telephone wiring or terminals unless the telephone line has been unplugged from the wall socket. Never connect the telephone line cord during a lightning storm or use it if it becomes frayed or damaged. Do not use a telephone wall socket in a location that is wet or may become wet, for example, near a refrigerator or other appliances that produce condensation. Doing this may cause an electrical shock.



(MFC only)

When using your telephone equipment, basic safety precautions should always be followed to reduce the risk of fire, electrical shock, and injury to people. These important safety precautions include the following:

- (1) DO NOT use this product near water or locations that may become wet, for example, near a bath tub, wash bowl, kitchen sink or washing machine, in a wet basement or near a swimming pool.
- (2) Avoid using this product during an electrical storm. There may be a remote risk of an electric shock from lightning.
- (3) DO NOT use this product to report a gas leak in the vicinity of the leak.
- (4) Use only the power cord provided with the product.

Read all of the instructions. Save them for later reference.



(MFC only)

To reduce the risk of shock or fire, use only a No. 26 AWG or larger telecommunication line cord.

IMPORTANT

- DO NOT remove or damage any of the caution or warning labels inside the product.

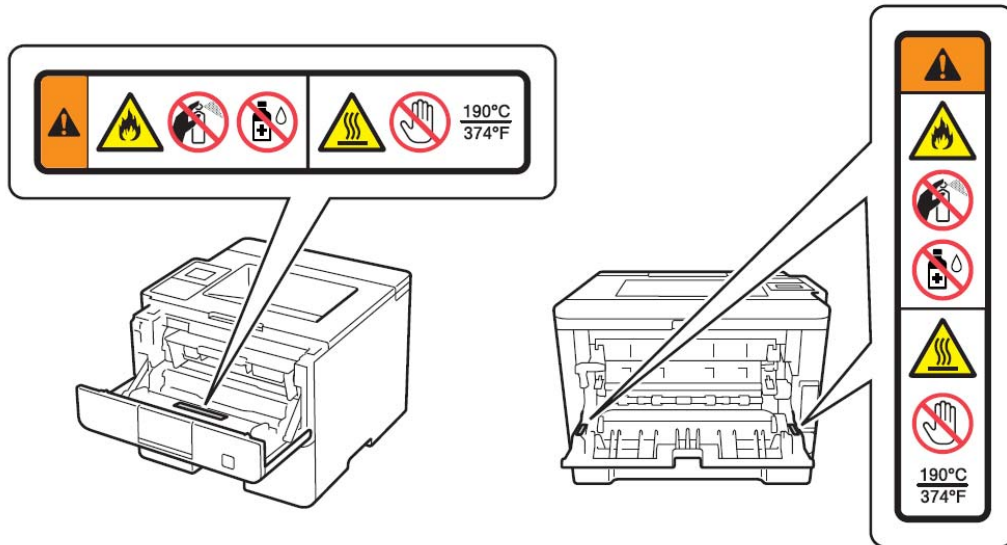

- DO NOT put objects on top of the product. Doing so could increase the risk of overheating should the product malfunction.

■ Caution for Laser Product (WARNHINWEIS für Laser drucker)

CAUTION: When the machine during servicing is operated with the cover open, the regulations of VBG 93 and the performance instructions for VBG 93 are valid.

CAUTION: In case of any trouble with the laser unit, replace the laser unit itself. To prevent direct exposure to the laser beam, do not try to open the enclosure of the laser unit.

ACHTUNG: Im Falle von Störungen der Lasereinheit muß diese ersetzt werden. Das Gehäuse der Lasereinheit darf nicht geöffnet werden, da sonst Laserstrahlen austreten können.

<Location of the laser beam window>

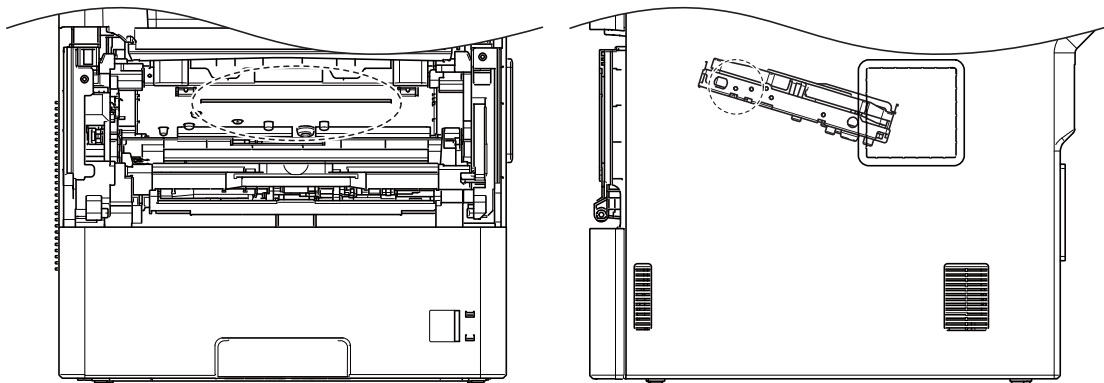

■ Additional Information

When servicing the optical system of the machine, be careful not to place a screwdriver or other reflective object in the path of the laser beam. Be sure to take off any personal accessories such as watches and rings before working on the machine. A reflected beam, though invisible, can permanently damage the eyes.

Since the beam is invisible, the following caution in print is attached on the laser unit.

In print



Unlawful use of copying equipment

It is an offence to make reproductions of certain items or documents with the intent to commit fraud. The following is a non-exhaustive list of documents which it may be unlawful to produce copies of. We suggest you check with your legal adviser and/or the relevant legal authorities if in doubt about a particular item or document:

- Currency
- Bonds or other certificates of indebtedness
- Certificates of Deposit
- Armed forces service or draft papers
- Passports
- Postage stamps (cancelled or uncanceled)
- Food stamps
- Immigration Papers
- Welfare documents
- Checks or drafts drawn by governmental agencies
- Identifying badges or insignias

In addition, driving licenses and/or Certificates of Title to motor vehicles may not be copied under certain national laws.

Copyrighted works cannot be copied lawfully, subject to the "fair dealing" exception relating to sections of a copyrighted work. Multiple copies would indicate improper use. Works of art should be considered the equivalent of copyrighted works.

CHAPTER 1 SUPPLEMENTAL SPECIFICATIONS

1. GENERAL

The function comparative tables for models as described in this Service Manual are shown below.

Model	DCP-L5500D	DCP-L5500DN DCP-L5502DN	DCP-L5600DN DCP-L5602DN	DCP-L5650DN DCP-L5652DN	DCP-L6600DW
Wired/ Wireless LAN	N/A	Wired			Wired/Wireless
Duplex Printing	✓				
Auto Duplex Copy	N/A			✓	
Duplex Scan	N/A			✓	
Scanning Method	CIS			Dual CIS	
LCD Type	3.7" TFT ColorLCD (9.3 cm / 93.4 mm)				4.85" TFT ColorLCD (12.3 cm / 123.2 mm)
FAX	N/A				
FB	A4/LTR		LGL		
USB Host (front)	✓				
USB Host (rear)	N/A				✓
NFC	N/A				✓
PCL/PS	N/A	✓			
Paper Input/ Standard Tray	250 sheets				520 sheets
Lower Tray (Option)	250 sheets (LT-5500) or 520 sheets (LT-6500) x 2 pcs (Max. 1,040 sheets)				
Tower Tray (Option)	N/A				✓

Specifications are subject to change without notice.

Model	MFC-8530DN MFC-8535DN	MFC-8540DN	MFC-L5700DN	MFC-L5700DW MFC-L5702DW	MFC-L5750DW
Wired/ Wireless LAN	Wired			Wired/Wireless	
Duplex Printing	✓				
Auto Duplex Copy	N/A	✓	N/A		✓
Duplex Scan	N/A	✓	N/A		✓
Scanning Method	CIS	Dual CIS	CIS		Dual CIS
LCD Type	3.7" TFT ColorLCD (9.3 cm / 93.4 mm)				4.85" TFT ColorLCD (12.3 cm / 123.2 mm)
FAX	✓				
FB	A4/LTR				
USB Host (front)	✓				
USB Host (rear)	N/A				
NFC	N/A	✓	N/A		
PCL/PS	✓				
Paper Input/ Standard Tray	250 sheets				
Lower Tray (Option)	250 sheets (LT-5500) or 520 sheets (LT-6500) x 2 pcs (Max. 1,040 sheets)				
Tower Tray (Option)	N/A				

Specifications are subject to change without notice.

Model	MFC-L5755DW	MFC-L5800DW MFC-L5802DW	MFC-L5850DW MFC-L5900DW MFC-L5902DW	MFC-L6700DW MFC-L6702DW MFC-L6750DW	MFC-L6800DW	MFC-L6900DW MFC-L6902DW
Wired/ Wireless LAN	Wired/Wireless					
Duplex Printing	✓					
Auto Duplex Copy	✓	N/A	✓			
Duplex Scan	✓	N/A	✓			
Scanning Method	Dual CIS	CIS	Dual CIS			
LCD Type	3.7" TFT ColorLCD (9.3 cm / 93.4 mm)			4.85" TFT ColorLCD (12.3 cm / 123.2 mm)		
FAX	✓					
FB	A4/LTR	LGL				
USB Host (front)	✓					
USB Host (rear)	N/A				✓	
NFC	N/A				✓	
PCL/PS	✓					
Paper Input/ Standard Tray	250 sheets			520 sheets		
Lower Tray (Option)	250 sheets (LT-5500) or 520 sheets (LT-6500) x 2 pcs (Max. 1,040 sheets)				250 sheets (LT-5500 for the U.S.A./ LT-5505 for Europe) or 520 sheets (LT-6500 for the U.S.A./ LT-6505 for Europe) x 2 pcs (Max. 1,040 sheets)	250 sheets (LT-5505) or 520 sheets (LT-6505) x 2 pcs (Max. 1,040 sheets)
Tower Tray (Option)	N/A				✓	

Specifications are subject to change without notice.

Model		DCP-L5500D	DCP-L5500DN DCP-L5502DN	DCP-L5600DN DCP-L5602DN	DCP-L5650DN DCP-L5652DN	DCP-L6600DW
Warm-up time	From Sleep mode	Less than 5.8 sec. at 73.4F / 50%RH (23°C / 50%RH) for the U.S.A./Brazil Less than 4.8 sec. at 73.4F / 50%RH (23°C / 50%RH) except for the U.S.A./Brazil				Less than 4.7 sec. at 73.4F / 50%RH (23°C / 50%RH)
	From Power OFF → ON	Less than 27 sec. at 73.4F / 50%RH (23°C / 50%RH)				
First print time	From Ready mode	Less than 7.2 secs at 73.4F (23°C)				Less than 7.5 secs at 73.4F (23°C)
	From Sleep mode	Less than 12.0 secs at 73.4F (23°C) for the U.S.A./Brazil Less than 13.0 secs at 73.4F (23°C) except for the U.S.A./Brazil				Less than 12.2 secs at 73.4F (23°C)
Printing speed (A4/Letter)		Up to 40/42 ppm (Quiet Mode: Up to 25/26 ppm)				Up to 46/48 ppm (Quiet Mode: Up to 25/26 ppm)
CPU		Cortex-A9 800 MHz				
Backup clock		Up to 60 hours				
Dimensions (W x D x H)	Carton size	545 x 520 x 641 mm (21.5 x 20.5 x 25.2 inch)		599 x 526 x 629 mm (23.6 x 20.7 x 24.8 inch)		599 x 526 x 659 mm (23.6 x 20.7 x 25.9 inch)
	Machine size	435 x 427 x 486 mm (17.1 x 16.8 x 19.1 inch)		495 x 427 x 486 mm (19.5 x 16.8 x 19.1 inch)		495 x 427 x 518 mm (19.5 x 16.8 x 20.4 inch)
Weights	with carton	20.2 kg / 44.5 lb	19.7 kg / 43.4 lb (for the U.S.A.) 19.7 kg / 43.5 lb (for Europe) 19.6 kg / 43.2 lb (for Brazil)	20.6 kg / 45.5 lb (for the U.S.A.) 20.6 kg / 45.3 lb (for Latin America) 21.1 kg / 46.6 lb (for Asia)	20.6 kg / 45.5 lb (for the U.S.A.) 20.6 kg / 45.3 lb (except for the U.S.A.)	22.3 kg / 49.1 lb
	without carton, with toner/drum	16.8 kg / 36.9 lb	16.3 kg / 36.0 lb (for the U.S.A. and Brazil) 16.4 kg / 36.1 lb (for Europe)	17.1 kg / 37.6 lb (except for Asia) 17.5 kg / 38.5 lb (for Asia)	17.1 kg / 37.6 lb	18.5 kg / 40.9 lb
	without carton and toner/drum	15.0 kg / 33.0 lb		15.7 kg / 34.6 lb		16.8 kg / 37.1 lb

Specifications are subject to change without notice.

Model		MFC-8530DN MFC-8535DN MFC-8540DN	MFC-L5700DN	MFC-L5700DW MFC-L5702DW	MFC-L5750DW	MFC-L5755DW
Warm-up time	From Sleep mode	Less than 5.8 sec. at 73.4F / 50%RH (23°C / 50%RH) for the U.S.A./Brazil Less than 4.8 sec. at 73.4F / 50%RH (23°C / 50%RH) except for the U.S.A./Brazil				
	From Power OFF → ON	Less than 27 sec. at 73.4F / 50%RH (23°C / 50%RH)				
First print time	From Ready mode	Less than 7.2 secs at 73.4F (23°C)				
	From Sleep mode	Less than 12.0 secs at 73.4F (23°C)		Less than 13.0 secs at 73.4F (23°C)		Less than 12.0 secs at 73.4F (23°C)
Printing speed (A4/Letter)		Up to 40/42 ppm (Quiet Mode: Up to 25/26 ppm)				
CPU		Cortex-A9 800 MHz				
Backup clock		Up to 60 hours				
Dimensions (W x D x H)	Carton size	585 x 556 x 651 mm (23.0 x 21.9 x 25.6 inch)	545 x 520 x 641 mm (21.5 x 20.5 x 25.2 inch)			
	Machine size	435 x 427 x 486 mm (17.1 x 16.8 x 19.1 inch)				
Weights	with carton	20.3 kg / 44.7 lb	20.1 kg / 44.2 lb (for Europe) 20.3 kg / 44.7 lb (for Asia)	19.8 kg / 43.6 lb (except for Brazil) 19.7 kg / 43.5 lb (for Brazil)	20.2 kg / 44.4 lb	19.8 kg / 43.7 lb (for Oceania) 20.4 kg / 44.9 lb (for Asia)
	without carton, with toner/drum	16.5 kg / 36.3 lb	16.5 kg / 36.3 lb (for Europe) 16.8 kg / 37.1 lb (for Asia)	16.4 kg / 36.2 lb	16.5 kg / 36.5 lb	16.5 kg / 36.4 lb (for Oceania) 16.9 kg / 37.3 lb (for Asia)
	without carton and toner/drum	15.3 kg / 33.7 lb	15.1 kg / 33.2 lb		15.2 kg / 33.4 lb	

Specifications are subject to change without notice.

Model		MFC-L5800DW MFC-L5802DW	MFC-L5850DW MFC-L5900DW	MFC-L5902DW	MFC-L6700DW	MFC-L6702DW
Warm-up time	From Sleep mode	Less than 5.8 sec. at 73.4F / 50%RH (23°C / 50%RH) for the U.S.A./Brazil Less than 4.8 sec. at 73.4F / 50%RH (23°C / 50%RH) except for the U.S.A./Brazil			Less than 5.7 sec. at 73.4F / 50%RH (23°C / 50%RH) for the U.S.A./Brazil Less than 4.7 sec. at 73.4F / 50%RH (23°C / 50%RH) except for the U.S.A./Brazil	
	From Power OFF → ON	Less than 27 sec. at 73.4F / 50%RH (23°C / 50%RH)				
First print time	From Ready mode	Less than 7.2 secs at 73.4F (23°C)			Less than 7.5 secs at 73.4F (23°C)	
	From Sleep mode	Less than 13.0 secs at 73.4F (23°C) for the U.S.A./Brazil Less than 12.0 secs at 73.4F (23°C) except for the U.S.A./Brazil			Less than 13.2 secs at 73.4F (23°C) for the U.S.A./Brazil Less than 12.2 secs at 73.4F (23°C) except for the U.S.A./Brazil	
Printing speed (A4/Letter)		Up to 40/42 ppm (Quiet Mode: Up to 25/26 ppm)			Up to 46/48 ppm (Quiet Mode: Up to 25/26 ppm) except for Asia Up to 50/52 ppm (Quiet Mode: Up to 25/26 ppm) for Asia	Up to 46/48 ppm (Quiet Mode: Up to 25/26 ppm)
CPU		Cortex-A9 800 MHz				
Backup clock		Up to 60 hours				
Dimensions (W x D x H)	Carton size	599 x 526 x 629 mm (23.6 x 20.7 x 24.8 inch)			599 x 526 x 659 mm (23.6 x 20.7 x 25.9 inch)	
	Machine size	495 x 427 x 486 mm (19.5 x 16.8 x 19.1 inch)			495 x 427 x 518 mm (19.5 x 16.8 x 20.4 inch)	
Weights	with carton	20.8 kg / 45.9 lb (for the U.S.A.) 20.7 kg / 45.7 lb (except for the U.S.A.)	20.9 kg / 46.0 lb	20.8 kg / 45.8 lb	22.1 kg / 48.7 lb (for the U.S.A.) 22.0 kg / 48.6 lb (for Latin America) 22.1 kg / 48.6 lb (for Oceania) 22.6 kg / 49.8 lb (for Asia)	22.0 kg / 48.6 lb
	without carton, with toner/ drum	17.2 kg / 37.9 lb (for the U.S.A.) 17.2 kg / 38.0 lb (except for the U.S.A.)	17.3 kg / 38.0 lb	17.3 kg / 38.1 lb	18.4 kg / 40.5 lb (except for Asia) 18.8 kg / 41.4 lb (for Asia)	
	without carton and toner/drum	15.9 kg / 34.9 lb	15.9 kg / 35.1 lb		17.0 kg / 37.5 lb	

Specifications are subject to change without notice.

Model		MFC-L6750DW	MFC-L6800DW	MFC-L6900DW	MFC-L6902DW
Warm-up time	From Sleep mode	Less than 5.7 sec. at 73.4F / 50%RH (23°C / 50%RH) for the U.S.A./Brazil Less than 4.7 sec. at 73.4F / 50%RH (23°C / 50%RH) except for the U.S.A./Brazil			
	From Power OFF → ON	Less than 27 sec. at 73.4F / 50%RH (23°C / 50%RH)			
First print time	From Ready mode	Less than 7.5 secs at 73.4F (23°C)			
	From Sleep mode	Less than 13.2 secs at 73.4F (23°C) for the U.S.A./Brazil Less than 12.2 secs at 73.4F (23°C) except for the U.S.A./Brazil			
Printing speed (A4/Letter)		Up to 46/48 ppm (Quiet Mode: Up to 25/26 ppm)		Up to 50/52 ppm (Quiet Mode: Up to 25/26 ppm)	
CPU		Cortex-A9 800 MHz			
Backup clock		Up to 60 hours			
Dimensions (W x D x H)	Carton size	599 x 526 x 762 mm (23.6 x 20.7 x 30.0 inch)	599 x 526 x 659 mm (23.6 x 20.7 x 25.9 inch) except for Italy-CONSIP 599 x 526 x 762 mm (23.6 x 20.7 x 30.0 inch) for Italy-CONSIP	599 x 526 x 762 mm (23.6 x 20.7 x 30.0 inch) except for Oceania 599 x 526 x 659 mm (23.6 x 20.7 x 25.9 inch) for Oceania	
	Machine size	495 x 427 x 518 mm (19.5 x 16.8 x 20.4 inch)			
Weights	with carton	23.3 kg / 51.4 lb	22.6 kg / 49.8 lb (for the U.S.A.) 22.9 kg / 50.4 lb (for Europe except Italy-CONSIP) 23.5 kg / 51.8 lb (for Italy-CONSIP)	23.5 kg / 51.8 lb (for the U.S.A.) 23.4 kg / 51.6 lb (for Latin America) 23.8 kg / 52.4 lb (for Europe) 22.5 kg / 49.7 lb (for Oceania) 23.7 kg / 52.3 lb (for Asia)	23.4 kg / 51.6 lb
	without carton, with toner/drum	18.8 kg / 41.4 lb	18.8 kg / 41.5 lb (for the U.S.A.) 18.9 kg / 41.6 lb (for Europe except Italy-CONSIP) 19.0 kg / 41.9 lb (for Italy-CONSIP)	19.0 kg / 41.9 lb (for the U.S.A./Latin America) 19.0 kg / 42.0 lb (for Europe) 18.9 kg / 41.6 lb (for Oceania) 19.1 kg / 42.2 lb (for Asia)	19.0 kg / 41.9 lb
	without carton and toner/drum	17.0 kg / 37.5 lb	17.2 kg / 37.9 lb		

Specifications are subject to change without notice.

■ **Option**

Model	LT		TT
	LT-5500 LT-5505 (250 sheets)	LT-6500 LT-6505 (520 sheets)	TT-4000
Dimensions (W x D x H)	363 x 384 x 122 mm (14.3 x 15.1 x 4.8 inch) The height 20 mm of its whole size is the boss parts which connects with the machine.	363 x 384 x 152 mm (14.3 x 15.1 x 6.0 inch) The height 20 mm of its whole size is the boss parts which connects with the machine.	660 x 660 x 717.4 mm (26.0 x 26.0 x 28.2 inch)
Weights	2.8 kg / 6.2 lb	3.9 kg / 8.5 lb	46.6 kg / 102.7 lb 47.7 kg / 105.2 lb with AC cord

Specifications are subject to change without notice.

2. NETWORK CONNECTIVITY

Model		DCP-L5500D	DCP-L5500DN DCP-L5502DN DCP-L5600DN DCP-L5602DN DCP-L5650DN DCP-L5652DN	DCP-L6600DW
Wired network	Network node type	N/A	NC-8900h	
Wireless network	Network node type	N/A		NC-8500w

Model		MFC-8530DN MFC-8535DN MFC-8540DN MFC-L5700DN	MFC-L5700DW MFC-L5702DW MFC-L5750DW MFC-L5755DW MFC-L5800DW MFC-L5802DW MFC-L5850DW MFC-L5900DW MFC-L5902DW	MFC-L6700DW MFC-L6702DW MFC-L6750DW MFC-L6800DW MFC-L6900DW MFC-L6903DW
Wired network	Network node type	NC-8900h		
Wireless network	Network node type	N/A	NC-8500w	

Specifications are subject to change without notice.

3. SERVICE INFORMATION

Model	DCP-L5500D DCP-L5500DN DCP-L5502DN DCP-L5600DN DCP-L5602DN DCP-L5650DN DCP-L5652DN	DCP-L6600DW	
Machine life	300,000 pages or 5 years	600,000 pages or 5 years	
Part life (ADF)	50,000 pages or 5 years		
Part life (Document scanner unit)	50,000 pages or 5 years		
MTBF	4,000 hours		
MTTR	0.5 hours		
Maximum monthly volume	Up to 50,000 pages	Up to 125,000 pages	
Periodical maintenance parts	Fuser unit	Up to 200,000 pages	
	Laser unit	Up to 200,000 pages	
	PF kit 1	Up to 100,000 pages	Up to 200,000 pages
	PF kit 2	Up to 200,000 pages	
	PF kit 3	Up to 200,000 pages	
	PF kit 4	Up to 200,000 pages	
	PF kit 5	Up to 200,000 pages	
	PF kit MP	Up to 50,000 pages	

Specifications are subject to change without notice.

* As for replacement of the periodical maintenance parts, refer to "PERIODICAL MAINTENANCE" in Chapter 7.

* PF kit 1 to 5 have same parts but their life cycles are different from the marketing strategical point of view.
(Alarm notification for part replacement sets off according to each model's life cycle.)

Model	MFC-8530DN MFC-8535DN MFC-8540DN MFC-L5700DN MFC-L5700DW MFC-L5702DW MFC-L5750DW MFC-L5755DW MFC-L5800DW MFC-L5802DW MFC-L5850DW MFC-L5900DW MFC-L5902DW	MFC-L6700DW MFC-L6702DW MFC-L6750DW	MFC-L6800DW	MFC-L6900DW MFC-L6902DW
Machine life	300,000 pages or 5 years		600,000 pages or 5 years	
Part life (ADF)	50,000 pages or 5 years			
Part life (Document scanner unit)	50,000 pages or 5 years			
MTBF	4,000 hours			
MTTR	0.5 hours			
Maximum monthly volume	Up to 50,000 pages	Up to 100,000 pages	Up to 125,000 pages	Up to 150,000 pages
Periodical maintenance parts	Fuser unit	Up to 200,000 pages		
	Laser unit	Up to 200,000 pages		
	PF kit 1	Up to 100,000 pages	Up to 200,000 pages	
	PF kit 2	Up to 200,000 pages		
	PF kit 3	Up to 200,000 pages		
	PF kit 4	Up to 200,000 pages		
	PF kit 5	Up to 200,000 pages		
	PF kit MP	Up to 50,000 pages		

Specifications are subject to change without notice.

* As for replacement of the periodical maintenance parts, refer to "PERIODICAL MAINTENANCE" in Chapter 7.

* PF kit 1 to 5 have same parts but their life cycles are different from the marketing strategical point of view.
(Alarm notification for part replacement sets off according to each model's life cycle.)

4. SUPPLIES

Model		DCP-L5500D	DCP-L5500DN	DCP-L5502DN	DCP-L5600DN
Toner cartridge	Starter Toner *1	Approx. 8,000 pages	Approx. 2,000 pages	Approx. 8,000 pages	Approx. 3,000 pages (except for Asia) Approx. 8,000 pages (for Asia)
	Standard Toner	Approx. 3,000 pages			
	High Capacity Toner	Approx. 8,000 pages			
	Super High Capacity Toner	N/A (for the U.S.A.) Approx. 12,000 pages (except for the U.S.A.)			
	Ultra High Capacity Toner	N/A			
When printing A4/Letter size one sided pages in accordance with ISO/IEC 19752 Shelf life: 2 years without opening (6 months after opening)					
Drum unit	Life expectancy: Approximately 30,000 pages (1 page/job), Approximately 50,000 pages (3 page/job) The life expectancy varies according to the use condition. Shelf life: 2 years				
The shelf life of toner cartridge and drum unit is guaranteed under the normal condition as below; (Temperature) Normal condition: 0 to 40°C (Humidity) Normal condition: 35%RH to 85%RH (without condensation) * Storage condition at the temperature of 50°C/90%RH: Up to 5 days * Storage condition at the temperature of -20°C: Up to 5 days					

Specifications are subject to change without notice.

*1 Toner supplied with the machine.

Model		DCP-L5602DN	DCP-L5650DN	DCP-L5652DN	DCP-L6600DW
Toner cartridge	Starter Toner *1	Approx. 8,000 pages	Approx. 3,000 pages	Approx. 8,000 pages	
	Standard Toner	Approx. 3,000 pages			
	High Capacity Toner	Approx. 8,000 pages			
	Super High Capacity Toner	N/A (for the U.S.A.) Approx. 12,000 pages (except for the U.S.A.)			
	Ultra High Capacity Toner	N/A			
When printing A4/Letter size one sided pages in accordance with ISO/IEC 19752 Shelf life: 2 years without opening (6 months after opening)					
Drum unit	Life expectancy: Approximately 30,000 pages (1 page/job), Approximately 50,000 pages (3 page/job) The life expectancy varies according to the use condition. Shelf life: 2 years				
The shelf life of toner cartridge and drum unit is guaranteed under the normal condition as below; (Temperature) Normal condition: 0 to 40°C (Humidity) Normal condition: 35%RH to 85%RH (without condensation) * Storage condition at the temperature of 50°C/90%RH: Up to 5 days * Storage condition at the temperature of -20°C: Up to 5 days					

Specifications are subject to change without notice.

*1 Toner supplied with the machine.

Model		MFC-8530DN MFC-8535DN MFC-8540DN	MFC-L5700DW MFC-L5702DW MFC-L5750DW MFC-L5755DW	MFC-L5800DW MFC-L5802DW MFC-L5900DW MFC-L5902DW	MFC-L6700DW MFC-L6702DW	MFC-L6750DW MFC-L6800DW	MFC-L6900DW MFC-L6902DW
Toner cartridge	Starter Toner ^{*1}	Approx. 3,000 pages	Approx. 2,000 pages (except for Asia, MFC-L5702DW) Approx. 8,000 pages (for Asia, MFC-L5702DW)	Approx. 3,000 pages (except for Asia, MFC-L5802DW / L5902DW) Approx. 8,000 pages (for Asia, MFC-L5802DW / L5902DW)	Approx. 3,000 pages (except for Asia, MFC-L6702DW) Approx. 8,000 pages (for Asia, MFC-L6702DW)	Approx. 8,000 pages (except for MFC-L6750DW) Approx. 12,000 pages (for MFC-L6750DW)	Approx. 8,000 pages (for Oceania) Approx. 12,000 pages (except for Singapore, Asia, Gulf, Korea, Oceania, MFC-L6902DW) 20,000 pages (for Singapore, Asia, Gulf, Korea, MFC-L6902DW)
	Standard Toner	Approx. 3,000 pages					
	High Capacity Toner	Approx. 8,000 pages					
	Super High Capacity Toner	Approx. 12,000 pages	Approx. 12,000 pages (for Asia, MFC-L5702DW) N/A (except for Asia, MFC-L5702DW)	Approx. 12,000 pages (except for the U.S.A.) N/A (for the U.S.A.)	Approx. 12,000 pages		
	Ultra High Capacity Toner	N/A					Approx. 20,000 pages
When printing A4/Letter size one sided pages in accordance with ISO/IEC 19798 Self life: 2 years without opening (6 months after opening)							
Drum unit	Life expectancy: Approximately 12,000 pages (1 page/job) The life expectancy varies according to the use condition. Shelf life: 2 years						
The shelf life of toner cartridge and drum unit is guaranteed under the normal condition as below; (Temperature) Normal condition: 0 to 40°C (Humidity) Normal condition: 35%RH to 85%RH (without condensation) * Storage condition at the temperature of 50°C/90%RH: Up to 5 days * Storage condition at the temperature of -20°C: Up to 5 days							

Specifications are subject to change without notice

*1 Toner supplied with the machine.

5. MEDIA SPECIFICATIONS

Model		All models
Paper input	ADF	Plain Paper, Recycled Paper
Media weight	ADF	64 to 90 g/m ² (17 to 24 lb)
Media size	ADF	Width 105 to 215.9 mm, Length 147.3 to 355.6 mm (Width 4.1" to 8.5", Length 5.8" to 14.0")

Specifications are subject to change without notice.

6. FAX (ONLY FOR THE MODELS WITH FAX FUNCTION)

Model	MFC-8530DN MFC-8535DN MFC-8540DN MFC-L5700DN MFC-L5700DW MFC-L5702DW MFC-L5750DW MFC-L5755DW MFC-L5800DW MFC-L5802DW	MFC-L5850DW MFC-L5900DW MFC-L5902DW MFC-L6700DW MFC-L6702DW MFC-L6750DW MFC-L6800DW MFC-L6900DW MFC-L6902DW
Modem speed	33,600 bps (Fax)	
Transmission speed	Approximately. 2.5 sec. (ITU-T Test Chart, Std resolution, JBIG)	
ITU-T group	Super G3	
Color FAX (Sending/Receiving)	N/A	
Internet FAX (ITU T.37 simple mode)	Yes (Download only)	Yes

Specifications are subject to change without notice.

7. COPY

Model		DCP-L5500D DCP-L5502DN DCP-L5600DN DCP-L5602DN	DCP-L5650DN DCP-L5652DN	DCP-L6600DW
Copy speed (A4/Letter)		Up to 40/42 cpm		Up to 46/48 cpm
First copy out time	From Ready mode and Paper tray	Less than 9.2 secs		Less than 9.5 secs
First copy out time	From Sleep mode and Paper tray	Less than 11.2 secs		Less than 11.5 secs
Print resolution (dpi)		1,200 x 600		
Auto duplex scanning copy		N/A	Yes	

Model		MFC-8530DN MFC-8535DN	MFC-L5700DN MFC-L5702DW MFC-L5800DW MFC-L5802DW	MFC-8540DN MFC-L5750DW MFC-L5755DW MFC-L5850DW MFC-L5900DW MFC-L5902DW	MFC-L6700DW MFC-L6702DW MFC-L6750DW MFC-L6800DW	MFC-L6900DW MFC-L6902DW
Copy speed (A4/Letter)		Up to 40/42 cpm			Up to 46/48 cpm (except for Asia) Up to 50/52 cpm (for Asia)	Up to 50/52 cpm
First copy out time	From Ready mode and Paper tray	Less than 9.2 secs			Less than 9.5 secs	
First copy out time	From Sleep mode and Paper tray	Less than 11.2 secs			Less than 11.5 secs	
Print resolution (dpi)		1,200 x 600				
Auto duplex scanning copy		N/A	Yes			

Specifications are subject to change without notice.

8. SCANNER

Model		DCP-L5500D DCP-L5502DN	DCP-L5600DN DCP-L5602DN	DCP-L5650DN DCP-L5652DN	DCP-L6600DW
Resolution (Optical)	FB	Max. 1,200 x 1,200 dpi			
	ADF	Max. 600 x 600 dpi			
Resolution (Interpolated)		Max. 19,200 x 19,200 dpi			
Scanning speed (Mono/Color) in accordance with ISO/IEC17991	Single (images / minute)	24/20	28/20		50/20
	Duplex (images / minute)	N/A		56/34	100/34

Model		MFC-8530DN MFC-8535DN MFC-L5700DN MFC-L5702DW	MFC-8540DN MFC-L5750DW MFC-L5755DW	MFC-L5800DW MFC-L5802DW	MFC-L5850DW MFC-L5900DW MFC-L5902DW MFC-L6700DW MFC-L6702DW MFC-L6750DW	MFC-L6800DW MFC-L6900DW MFC-L6902DW
Resolution (Optical)	FB	Max. 1,200 x 1,200 dpi				
	ADF	Max. 600 x 600 dpi				
Resolution (Interpolated)		Max. 19,200 x 19,200 dpi				
Scanning speed (Mono/Color) in accordance with ISO/IEC17991	Single (images / minute)	24/20		28/20		50/20
	Duplex (images / minute)	N/A	48/34	N/A	56/34	100/34

Specifications are subject to change without notice.

CHAPTER 2 ERROR INDICATIONS & TROUBLESHOOTING

1. INTRODUCTION

Troubleshooting is a collection of solution procedures that service personnel should follow if an error or malfunction occurs in the machine. It is difficult to determine troubleshooting procedures for all possible problems that may occur in the future. Therefore, this chapter describes typical problems and recovery procedures for these. These will help service personnel identify and repair other similar defective sections.

1.1 Precautions

Be sure to observe the following precautions to prevent any secondary problems occurring during troubleshooting:

- (1) Be sure to unplug the AC cord before removing any covers or PCBs, or adjusting the machine.
- (2) Do not hold the cable when connecting or disconnecting the cable. Be sure to hold the connector.
- (3) Static electricity charged in your body may damage electronic parts. Before handling the PCBs, touch a metal section of the machine to discharge static electricity. When transporting PCBs, be sure to wrap them in conductive sheets. When replacing the PCBs, wear a grounding wrist band and perform replacement on an antistatic mat. Also take care not to touch the conductor sections on the flat cables.
- (4) Be sure to always observe all warnings.

 **Warning**

Hazard labels as shown below are attached to the machine. Fully understand the descriptions on the hazard labels and observe them during troubleshooting. Take extreme care not to remove or damage the hazard labels.

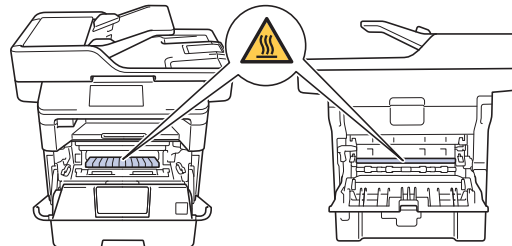

 **Warning**

DO NOT use any flammable spray or flammable solvent such as alcohol, benzene, or thinner in or around the machine. Otherwise a fire or electric shock may result.



- (5) After repair is completed, check that the repaired sections, including those removed once and then remounted, operate normally.

A certain interface or function could be set to invalid to serve the needs of customers. Ask sales representative if this is the case before performing the check.

1.2 Checks before Commencing Troubleshooting

Check the following items before commencing repairs on the machine.

■ Operating environment

- (1) The machine is placed on a flat, stable surface.
- (2) The machine is used in a clean environment where the temperature is 10°C (50°F) to 32°C (89.6°F), and the relative humidity is maintained between 20% and 80%.
- (3) The machine is not exposed to direct sunlight, excessive heat, moisture, or dust.
- (4) Hold the machine level while moving it. Be sure to move or lift the machine with 2 or more people.

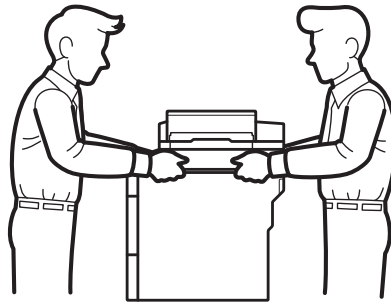

Fig. 2-1

■ Power supply

- (1) Power described on the rating label attached on the machine is supplied. Power fluctuation should be within $\pm 10\%$ of the rated voltage.
- (2) The AC input power supply is within the regulated value.
- (3) The cables and harnesses are connected correctly.
- (4) The fuses are not blown.

■ Paper

- (1) The recommended type of paper is being used.
- (2) The paper is not damp.
- (3) Short-grained paper or acid paper is not used.

■ Consumable parts

- (1) The drum unit (including toner cartridge) is set correctly.

■ Others

(1) Condensation

When the machine is moved to a warm room from a cold location, condensation may occur inside the machine, causing various problems as listed below.

- Condensation on the surface of optical devices such as the lens, reflecting mirror and protection glass may cause light print image.
- If the exposure drum is cold, the electrical resistance of the photosensitive layer is increased, making it impossible to obtain the correct print density.
- Condensation on the charge unit may cause corona charge leakage.
- Condensation on the plate or separation pad may cause paper feed problems.

If condensation has formed in the machine, leave the machine for at least two hours until it reaches room temperature.

If the drum unit is unpacked soon after it is moved to a warm room from a cold location, condensation may occur inside the unit which may cause printing failure. Leave the drum unit for one or two hours until it reaches room temperature, and then unpack it.

(2) Low temperature

The motor may not operate normally in a cold environment because too much load is applied to each drive. In this case, increase the room temperature.

■ Cleaning

Use a soft lint-free cloth.

Warning

DO NOT use any flammable spray or flammable solvent such as alcohol, benzene, or thinner to clean the machine. DO NOT use these articles near the machine.



2. OVERVIEW

2.1 Cross-section Drawing

2.1.1 Printer part

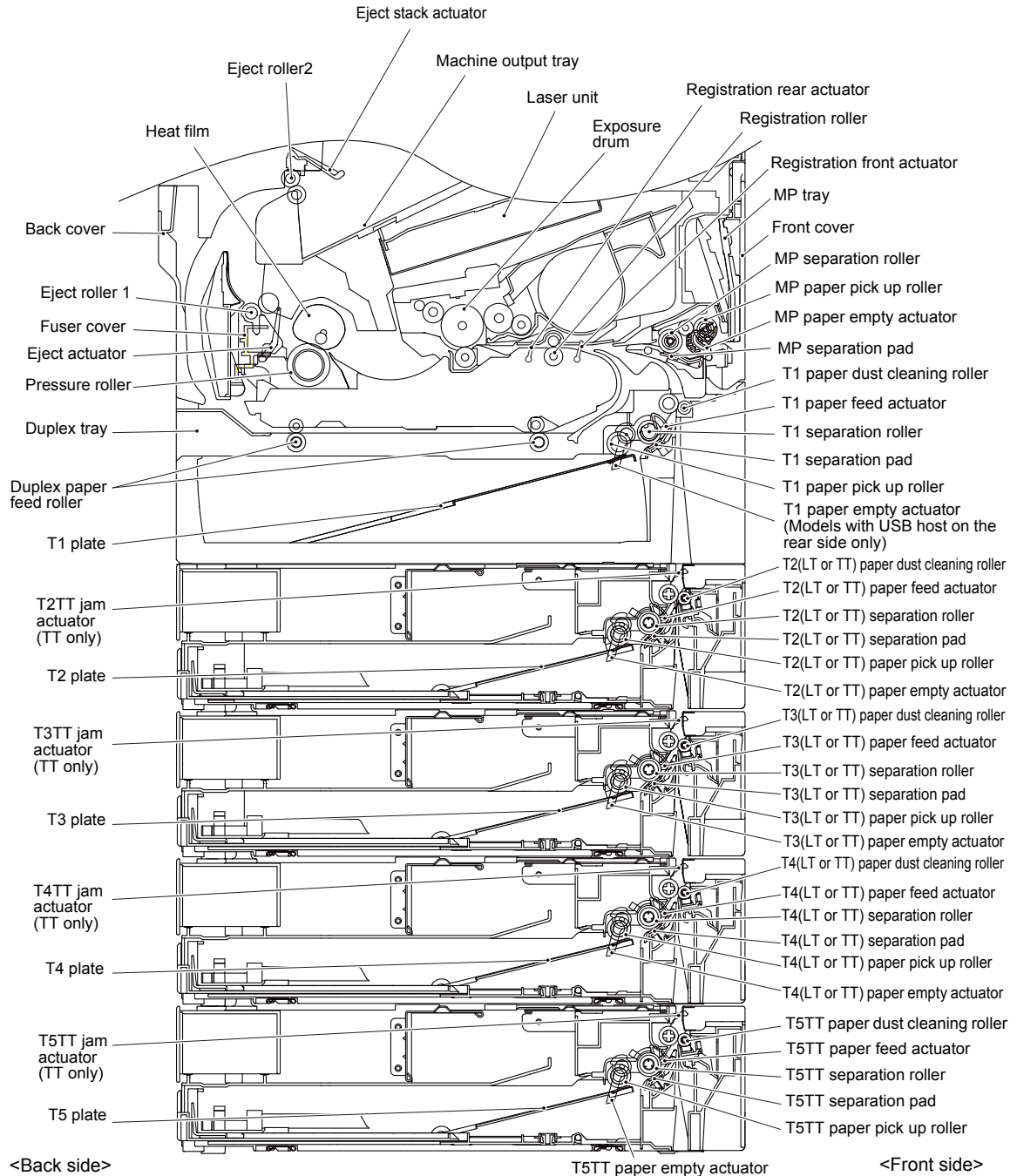

Fig. 2-2

2.1.2 Scanner part

■ Common to Legal / A4 models

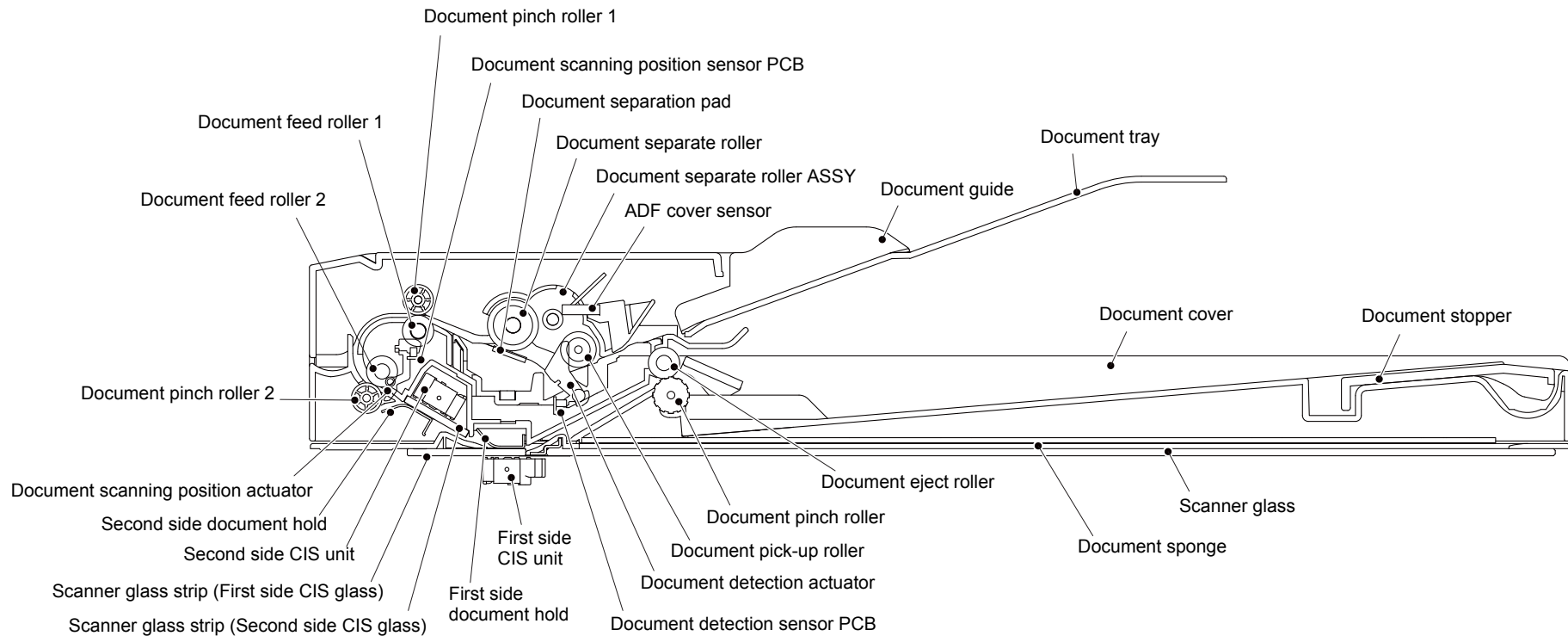

Fig. 2-3

2.2 Paper Feeding

2.2.1 Printer part

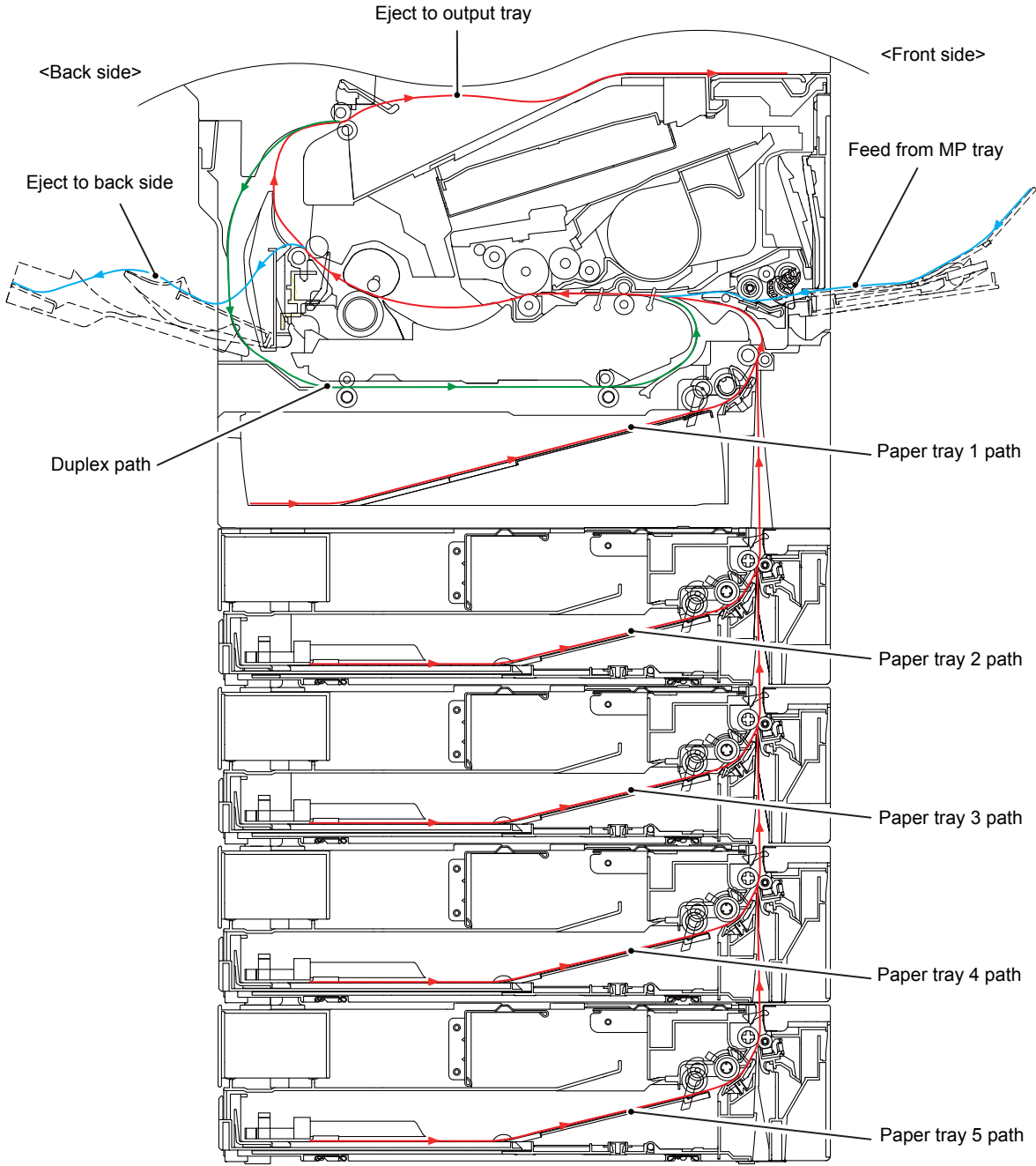

Fig. 2-4

2.2.2 Scanner part

- Common to Legal / A4 models

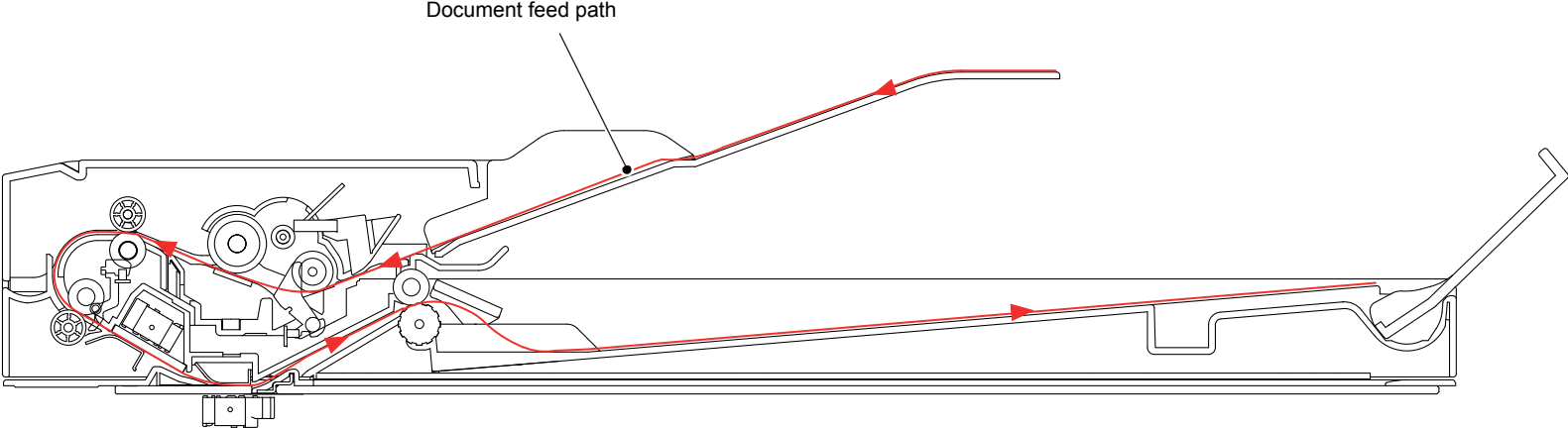

Fig. 2-5

2.3 Operation of Each Part

Part name	Operation
Paper pick up roller	Feeds paper from the paper tray to the separation roller.
Separation roller, Separation pad	Separates paper fed from the paper tray into single sheets.
Paper feed actuator (Paper feed sensor)	Detects paper trays (open / closed). Detects paper jams in paper trays. Determines whether paper is fed from the paper tray.
Paper empty actuator (Paper empty sensor)	Detects paper in the paper tray. (Models with LT, TT, and USB host on the rear side only.)
TT jam actuator (TT jam sensor)	Detects paper jams in the front section of the tray. (TT only)
TT balance sensor L/R	Detects if the TT is mounted properly. (TT only)
Registration front actuator (Registration front sensor)	Detects the front edge of the paper to control the registration roller drive. Detects paper jams in the front section of the machine. Determines whether paper is fed from the paper tray.
Registration roller	Corrects the paper alignment when the paper makes contact with the stopped registration roller. After the correction, it rotates to feed the paper to the feeding path.
Registration rear actuator (Registration rear sensor)	Detects paper pass and adjusts the writing start position for the paper. Detects paper jams in the front or center section of the machine. Detects the rear edge of the paper to determine the paper size.
Heat film, Pressure roller	Fuses the toner transferred to paper by heat and pressure, and feeds paper to the eject roller 1.
Eject actuator (Eject sensor)	Determines whether paper is ejected from the fuser unit. Detects the rear edge of the paper in duplex printing mode to adjust the turn-over timing of the eject roller 2. Detects paper jam in the rear section of the machine.
Eject roller 1	Feeds the paper ejected from the fuser unit to eject roller 2.
Eject roller 2	Ejects the paper to the output tray of the machine. During the duplex printing, the eject roller 2 rotates conversely and feeds the paper to the duplex tray after the paper has been fed from the eject roller 2 with the second side printed.
Duplex paper feed roller	Feeds the paper passing through the duplex tray to the registration roller.
Front cover sensor	Detects open front cover.
Back cover/duplex tray sensor	Detects open / closed back cover or the duplex tray is set.
MP paper pick up roller	Feeds paper from the MP tray to the MP separation roller.

Part name	Operation
MP separation roller, MP separation pad	Separates the paper fed from the MP tray into single sheets in the MP separation roller.
MP paper empty actuator (MP paper empty sensor)	Detects the paper in the MP tray. Detects paper jams in the MP tray.
Eject stack actuator (Eject stack sensor)	Detects the full of a machine output tray. (Models with USB host on the rear side only.)
Document pick-up roller	Feeds document from the document tray.
Document separate roller, ADF separation pad	Separates the document fed from the document tray into single sheets.
Document detection actuator (Document detection sensor)	Detects whether a document is set in the ADF.
Document scanning position actuator (Document scanning position sensor)	Detects the document scanning start position. Detects a document jam in the ADF.
Document eject roller	Feeds the document to the output tray.
ADF cover sensor	Detects open / closed ADF cover.

2.4 Block Diagram

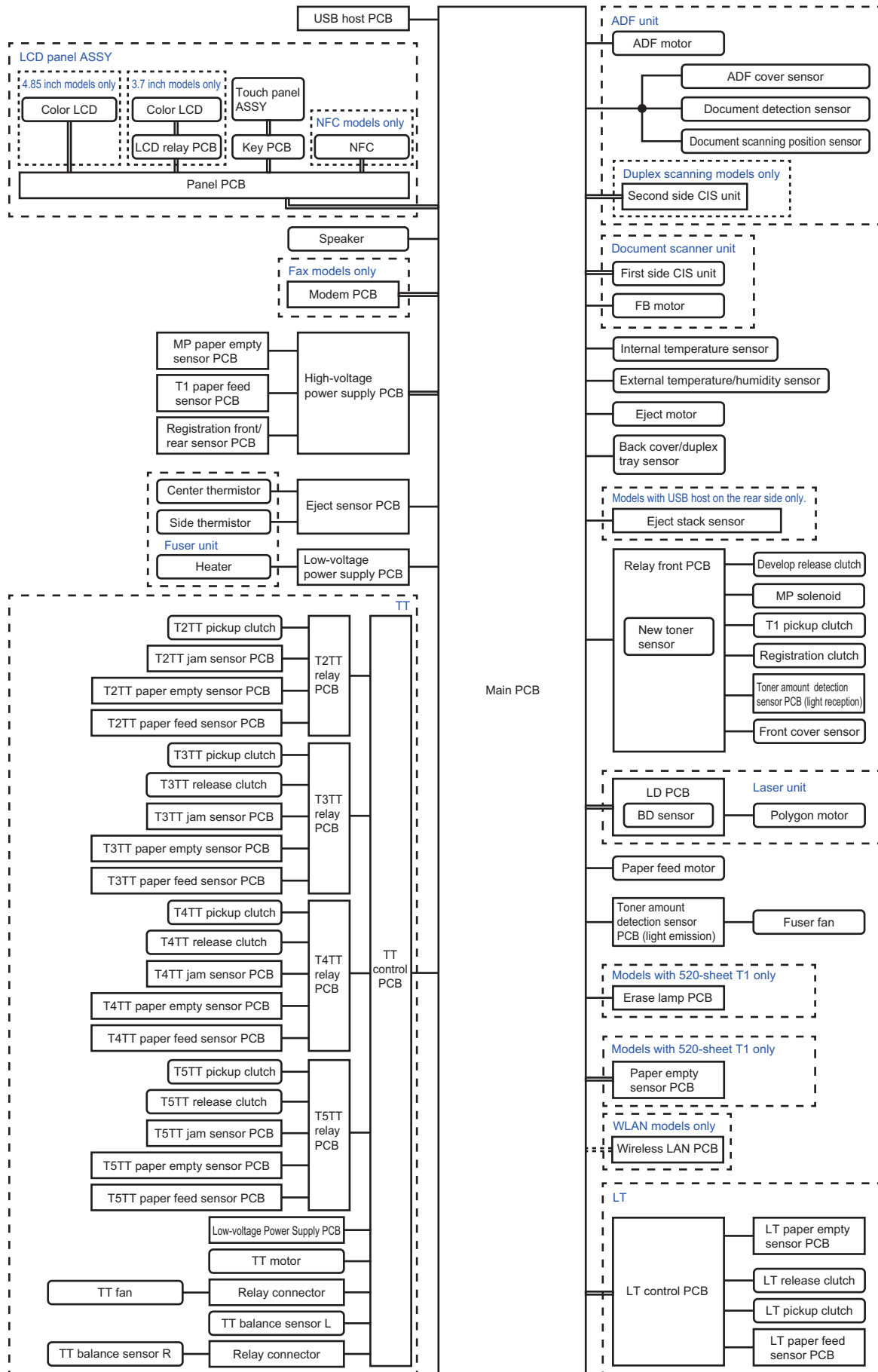

Fig. 2-6

2.5 Main Components

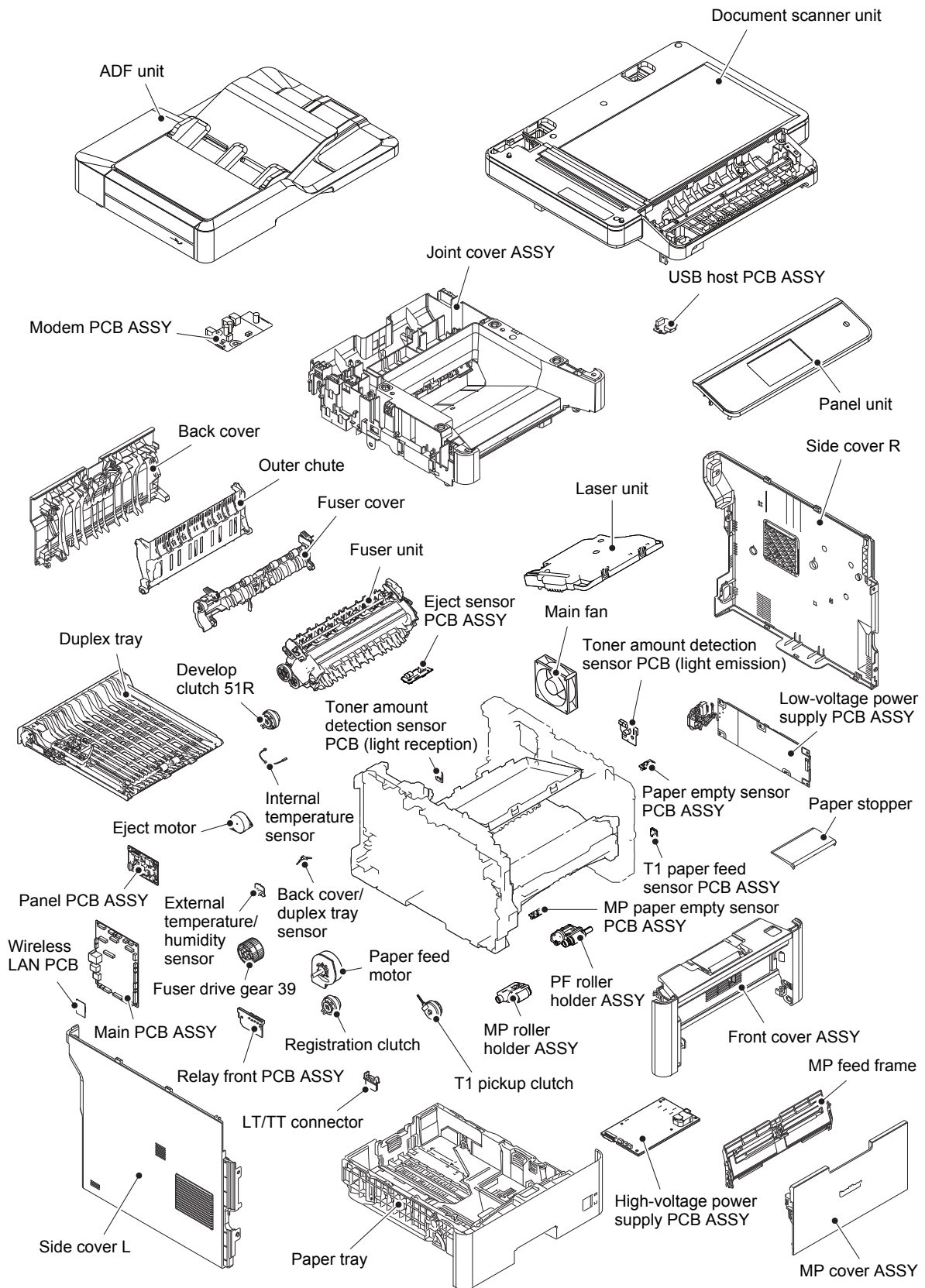

Fig. 2-7

3. ERROR INDICATIONS

This machine includes a self-diagnosis function. If the machine does not work normally it judges that an error has occurred, and indicates the corresponding error message on the LCD, which in turn helps the service personnel to quickly find out the problem.

3.1 Error Codes

Errors in shaded column do not usually occur during normal use. The possible causes are noise around the installation site, fluctuation of the power supply voltage, and failures in the software.

Error codes	Description	Refer to:	Error codes	Description	Refer to:
0101	—		0504	After the heat unit was heated normally, the center thermistor of the fuser unit detected a temperature lower than the specified value.	2-40
0102	Communication error between the engine ASIC and motor driver or faulty motor driver.	2-38	0505	The center thermistor of the fuser unit detected a temperature rise greater than the specified value within the specified time.	2-40
0201	Cannot detect the synchronized signal of the paper feed motor. The speed of the paper feed motor does not stabilize within the specified time.	2-38	0506	The center thermistor of the fuser unit detected a temperature fall greater than the specified value within the specified time.	2-40
0202	—		0508	The side thermistor of the fuser unit did not detect a temperature rise when the heater was ON.	2-40
0203	Eject motor failure was detected.	2-38	050A	The hardware detected a temperature error through the center thermistor or the side thermistor of the fuser unit.	2-41
0300	Cannot detect the lock signal of the polygon motor for the laser unit (second time).	2-39	050B	When the center thermistor of the fuser unit was lower than the idle temperature, the side thermistor detected a temperature higher than the specified temperature.	2-41
0305	Cannot detect the lock signal of the polygon motor for the laser unit (first time).	2-39	050C	When the center thermistor of the fuser unit was higher than the idle temperature, the side thermistor detected a temperature lower than the specified temperature.	2-41
0401	Cannot detect the synchronized signal of the polygon motor for the laser unit (second time).	2-39	050D	—	
0402	—		050F	—	
0405	Cannot detect the synchronized signal of the polygon motor for the laser unit (first time).	2-39	0800	An error occurred in the internal temperature sensor.	2-41
0501	The center thermistor of the fuser unit has not reached the specified temperature within the specified time.	2-40	0900	Detected irregular power supply for more than 100 times.	2-42
0502	The center thermistor of the fuser unit has not reached the specified temperature within the specified time after it was heated normally to the certain level.	2-40	0A01	—	
0503	The center thermistor of the fuser unit detected a temperature higher than the specified value.	2-40	0A02	Detected a main fan failure.	2-42

Error codes	Description	Refer to:	Error codes	Description	Refer to:
0B01	An error occurred in the high-voltage power supply PCB ASSY while operating.	2-42	2102	—	
0B02	An error occurred in the high-voltage power supply PCB ASSY when the machine was in the ready state.	2-42	2103	—	
0C00	—		2104	—	
0D01	—		2105	—	
0D02	—		2201	—	
0D03	—		2202	—	
0D04	—		2203	—	
0E00	—		2204	—	
1003	—		2205	—	
1004	—		2206	—	
1100	—		2207	—	
1200	—		2301	—	
1300	—		2302	—	
1400	—		2401	—	
1701	Detected a TT fan failure.	2-43	2402	—	
1801	A communication error occurred between the ASIC and T2LT control PCB in the engine. (LT only)	2-43	2403	—	
1802	A communication error occurred between the ASIC and T3LT control PCB ASSY in the engine. (LT only)	2-43	2404	—	
1803	—		2405	—	
1808	A communication error occurred between the ASIC and TT control PCB in the engine.	2-43	2408	—	
1901	Detected a TT motor failure.	2-44	2409	—	
1A01	—		2501	—	
1B01	—		2502	—	
1C00	—		2503	—	
1D01	—		2504	—	
1D02	—		2601	—	
1D03	—		2602	—	
1D04	—		2603	—	
1E01	—		2604	—	
1E02	—		2605	—	
1F00	When the TT was connected, TT balance sensor L/R wasn't connected properly.	2-44	2701	—	
2001	—		2702	—	
2002	—		2703	—	
2003	—		2801	—	
2004	—		2802	—	
2005	—		2803	—	
2006	—		2804	—	
2101	—		2805	—	

Error codes	Description	Refer to:	Error codes	Description	Refer to:
2806	—		3202	—	
2901	—		3301	—	
2902	—		3302	—	
2903	—		3401	—	
2904	—		3402	—	
2905	—		3501	—	
2906	—		3601	—	
2A01	—		3701	—	
2A02	—		3702	—	
2A03	—		3703	—	
2B01	—		3801	A temperature error occurred in the external temperature/humidity sensor.	2-44
2B02	—		3802	—	
2C01	—		3900	—	
2C02	—		3A00	—	
2D01	—		4000	The number of rotations of the drum unit is reaching the upper limit.	2-44
2E01	—		4001	—	
2E02	—		4002	—	
2E03	—		4003	—	
2E04	—		4004	—	
2E05	—		4200	The number of rotations of the drum unit has reached the upper limit. (Printing does not stop.)	2-44
2E06	—		4201	—	
2E07	—		4202	—	
2E08	—		4203	—	
2E0A	—		4204	—	
2F01	—		4300	—	
2F02	—		4400	—	
2F03	—		4500	The number of printable pages of the fuser unit has reached the upper limit.	2-45
2F04	—		4600	The number of printable pages of the laser unit has reached the upper limit.	2-45
2F05	—		4700	—	
2F06	—		4800	—	
2F07	—		4900	—	
2F08	—		4A00	—	
2F0A	—		4B01	Dot counter or develop roller counter of the toner is reaching the upper limit.	2-45
3001	—		4B02	—	
3002	—		4B03	—	
3003	—		4B04	—	
3102	—		4C01	Dot counter or develop roller counter of the toner has reached the upper limit.	2-45

Error codes	Description	Refer to:	Error codes	Description	Refer to:
4C02	—		5902	—	
4C03	—		5A02	—	
4C04	—		5B02	—	
4C05	—		5C02	—	
4D01	—		6001	The front cover sensor detected that the front cover was open.	2-47
4E01	—		6002	—	
4F01	The new toner sensor could not detect the new toner cartridge correctly.	2-46	6003	—	
4F02	—		6004	The eject sensor detected that the fuser cover was open.	2-47
4F03	—		6007	—	
4F04	—		6101	The toner amount detection sensor detected that the toner cartridge was not set.	2-47
5001	Printable pages set for PF kit MP have reached the upper limit.	2-46	6102	—	
5002	Printable pages set for PF kit 1 have reached the upper limit.	2-46	6103	—	
5003	Printable pages set for PF kit 2 have reached the upper limit.	2-46	6104	—	
5004	Printable pages set for PF kit 3 have reached the upper limit.	2-46	6200	Detected that the drum unit was not set by detecting the GRID terminal current.	2-48
5005	Printable pages set for PF kit 4 have reached the upper limit.	2-46	6201	—	
5006	Printable pages set for PF kit 5 have reached the upper limit.	2-46	6202	—	
5100	—		6203	—	
5200	—		6204	—	
5301	—		6208	—	
5302	—		6209	—	
5401	—		620A	—	
5402	—		6300	—	
5406	—		6400	—	
5502	—		6602	—	
5602	—		6701	—	
5702	—		6801	The side thermistor of the fuser unit or internal temperature sensor detected a temperature higher than the specified value.	2-49
5801	—		6802	—	
5802	—		6901	An error occurred in the fuser unit when the power switch was turned ON or sleep mode was released.	2-49

Error codes	Description	Refer to:	Error codes	Description	Refer to:
6902	Rechecking the error after the power switch was turned OFF and then ON again because an error was detected in the fuser unit. (This message is displayed for approximately 15 minutes when the machine is restarted after error code 6901 has occurred.)	2-49	7100	The eject sensor remains ON (paper pass detected) even after the registration rear sensor detected the end of paper pass.	2-51
6A00	Detected discharge that may be attributable to dirty corona wire on the drum unit.	2-50	7101	—	
6B01	—		7102	—	
6B02	—		7103	—	
6B03	—		7104	—	
6B04	—		7105	—	
6B0A	—		7106	—	
6C01	—		7200	When feeding from the MP tray, the registration rear sensor does not detect paper pass within the specified time after the registration front sensor detected paper pass.	2-52
6C02	—		7201	—	
6C03	—		7300	—	
6C04	—		7301	When printing from the paper tray 1, the T1 paper feed sensor does not detect paper pass within the specified time while the T1 paper empty sensor detects some paper set.	2-53
6D00	Detected more LTs than connectible limit.	2-50	7302	When printing from the paper tray 1, the registration front sensor does not detect paper pass within the specified time after the T1 paper feed sensor detected paper pass.	2-53
6E00	—		7400	—	
6F00	Detected irregular power supply for less than 100 times.	2-50	7401	When printing from the paper tray 2, the T2(LT or TT) paper feed sensor does not detect paper pass within the specified time while the T2(LT or TT) paper empty sensor detects some paper set.	2-54
7000	The eject sensor does not detect paper pass after the registration rear sensor detected the paper pass.	2-51	7402	When printing from the paper tray 2, the registration front sensor or the T2TT jam sensor does not detect paper pass within the specified time after the T2(LT or TT) paper feed sensor detected paper pass.	2-55
7001	—		7500	—	
7002	—		7501	When printing from the paper tray 3, the T3(LT or TT) paper feed sensor does not detect paper pass within the specified time while the T3(LT or TT) paper empty sensor detects some paper set.	2-56
7003	—		7502	When printing from the paper tray 3, the registration front sensor or the T2/ T3TT jam sensor does not detect paper pass within the specified time after the T3(LT or TT) paper feed sensor detected paper pass.	2-57
7004	—		7601	When printing from the paper tray 4, the T4(LT or TT) paper feed sensor does not detect paper pass within the specified time while the T4(LT or TT) paper empty sensor detects some paper set.	2-58

Error codes	Description	Refer to:	Error codes	Description	Refer to:
7602	When printing from the paper tray 4, the registration front sensor or the T2/T3/T4TT jam sensor does not detect paper pass within the specified time after the T4(LT or TT) paper feed sensor detected paper pass.	2-59	7C00	—	
7701	When printing from the paper tray 5, the T5TT paper feed sensor does not detect paper pass within the specified time while the T5TT paper empty sensor detects some paper set.	2-60	7D00	—	
7702	When printing from the paper tray 5, the registration front sensor or the T2/T3/T4/T5TT jam sensor does not detect paper pass within the specified time after the T5TT paper feed sensor detected paper pass.	2-61	7E00	—	
7800	The registration front sensor does not detect paper pass within the specified time after the first side was printed in duplex printing mode.	2-62	7F00	—	
7801	—		8000	—	
7802	—		8100	—	
7803	—		8401	—	
7804	—		8402	—	
7805	—		8403	—	
7900	—		8501	When printing from paper tray 1 to 5, the T1 paper feed sensor detected open paper tray 1 (before registering printing data to engine).	2-63
7A01	—		8502	When printing from paper tray 2 to 5, the T2(LT or TT) paper feed sensor detected open paper tray 2 (before registering printing data to engine).	2-63
7A02	—		8503	When printing from paper tray 3 to 5, the T3(LT or TT) paper feed sensor detected open paper tray 3 (before registering printing data to engine).	2-63
7B01	—		8504	When printing from paper tray 4 to 5, the T4(LT or TT) paper feed sensor detected open paper tray 4 (before registering printing data to engine).	2-63
7B02	—		8505	When printing from paper tray 1 to 5, the T1 paper feed sensor detected open paper tray 1 (after registering printing data to engine).	2-64
7B03	—		8506	When printing from paper tray 2 to 5, the T2(LT or TT) paper feed sensor detected open paper tray 2 (after registering printing data to engine).	2-64
7B04	—		8507	When printing from paper tray 3 to 5, the T3(LT or TT) paper feed sensor detected open paper tray 3 (after registering printing data to engine).	2-64
7B05	—		8508	When printing from paper tray 4 to 5, the T4(LT or TT) paper feed sensor detected open paper tray 4 (after registering printing data to engine).	2-64

Error codes	Description	Refer to:	Error codes	Description	Refer to:
8601	—		8903	The back cover/duplex tray sensor detected that the cover was open when duplex printing is started. (Before registering printing data to engine)	2-65
8602	—		8904	The back cover/duplex tray sensor detected that the cover was open during duplex printing. (After registering printing data to engine)	2-65
8603	—		8A01	The registration rear sensor detected that the paper fed was smaller or larger than the specified size in duplex printing mode.	2-65
8604	—		8A02	—	
8701	—		8B01	Detected that the TT was not turned ON.	2-66
8702	Machine stack sensor detected the ejected paper full state at the start of printing.	2-64	8C00	—	
8703	—		8D01	—	
8708	—		8D02	—	
8709	—		8E01	—	
870A	—		8E02	Detected that the size of paper set in the paper tray was over 10 mm shorter than letter size during receiving fax data or printing a list or report.	2-66
870B	—		8F01	—	
870C	—		8F02	—	
870D	—		8F03	—	
870E	—		9001	When printing from the MP tray, the size of paper set in the MP tray does not match the size specified by the driver.	2-67
870F	—		9002	When printing from the paper tray 1, the size of paper set in the paper tray 1 does not match the size specified by the driver.	2-67
8801	—		9003	When printing from the paper tray 2, the size of paper set in the paper tray 2 does not match the size specified by the driver.	2-67
8802	—		9004	When printing from the paper tray 3, the size of paper set in the paper tray 3 does not match the size specified by the driver.	2-67
8808	—		9005	When printing from the paper tray 4, the size of paper set in the paper tray 4 does not match the size specified by the driver.	2-67
8809	—		9006	When printing from the paper tray 5, the size of paper set in the paper tray 5 does not match the size specified by the driver.	2-67
880A	—		9102	—	
8901	—		9103	—	
8902	—		9104	—	

Error codes	Description	Refer to:	Error codes	Description	Refer to:
9105	—		9502	—	
9200	—		9503	—	
9201	When printing from the MP tray, paper type setting in the machine does not match the setting in the driver.	2-68	9504	—	
9202	When printing from the paper tray 1, paper type setting in the machine does not match the setting in the driver.	2-68	9505	—	
9203	When printing from the paper tray 2, paper type setting in the machine does not match the setting in the driver.	2-68	9601	—	
9204	When printing from the paper tray 3, paper type setting in the machine does not match the setting in the driver.	2-68	9608	—	
9205	When printing from the paper tray 4, paper type setting in the machine does not match the setting in the driver.	2-68	9701	A tray set to duplex printing-incompatible size was specified in duplex printing.	2-72
9206	When printing from the paper tray 5, paper type setting in the machine does not match the setting in the driver.	2-68	9702	When printing from paper tray 1, a paper size not supported for paper tray 1 was specified from the driver.	2-72
9301	When printing from the MP tray, the MP paper empty sensor detected that there was no paper set in the MP tray.	2-69	9703	When printing from paper tray 2, a paper size not supported for paper tray 2 was specified from the driver.	2-72
9302	When printing from paper tray 1, the T1 paper empty sensor or the T1 paper feed sensor detected that there was no paper set in paper tray 1.	2-69	9704	When printing from paper tray 3, a paper size not supported for paper tray 3 was specified from the driver.	2-72
9303	When printing from paper tray 2, the T2(LT or TT) paper empty sensor detected that there was no paper set in paper tray 2.	2-69	9705	When printing from paper tray 4, a paper size not supported for paper tray 4 was specified from the driver.	2-72
9304	When printing from paper tray 3, the T3(LT or TT) paper empty sensor detected that there was no paper set in paper tray 3.	2-69	9706	When printing from paper tray 5, a paper size not supported for paper tray 5 was specified from the driver.	2-72
9305	When printing from paper tray 4, the T4(LT or TT) paper empty sensor detected that there was no paper set in paper tray 4.	2-69	9801	—	
9306	When printing from paper tray 5, the T5TT paper empty sensor detected that there was no paper set in paper tray 5.	2-69	9802	—	
9309	Detected that there was no paper set in all trays when TrayAuto was selected for printing.	2-70	9803	—	
930A	Paper ran out during Fax / List continuous printing.	2-71	9804	—	
9400	Firmware version of the main PCB is older than that of the TT and LT.	2-71	9901	—	
9501	—		9902	—	

Error codes	Description	Refer to:	Error codes	Description	Refer to:
9903	—		A700	Color parameter in the ROM does not match the first side or second side CIS.	2-75
9A01	—		A800	—	
9A02	—		A900	A scanning error occurred while processing the scanned image.	2-75
9A03	—		AA00	—	
9B01	—		AB00	—	
9B02	—		AC00	When scanning the fax, white or black correction data for the second side CIS was not within the correct range (first time).	2-75
9B03	Only T2 tray is set for A4 / Letter / Legal / Folio but T2 is set as "Skip Tray".	2-72	AD00	Image processing cannot be completed correctly because the number of pixels required for image processing is insufficient in the scanned first side data.	2-75
9B04	Only T3 tray is set for A4 / Letter / Legal / Folio but T3 is set as "Skip Tray".	2-72	AE00	Unit home position could not be detected after the power switch was turned ON.	2-76
9B05	Only T4 tray is set for A4 / Letter / Legal / Folio but T4 is set as "Skip Tray".	2-72	AF00	Home position is still being detected even after the first side CIS unit was moved.	2-76
9B06	Only T5 tray is set for A4 / Letter / Legal / Folio but T5 is set as "Skip Tray".	2-72	B000	Detected that the first side CIS flat cable or second side CIS flat cable was not inserted correctly when function code 55 was executed.	2-76
9C01	—		B700	—	
9C02	—		B800	—	
9C03	—		B900	—	
9C06	—		BB00	A white level not within the standard was scanned when function code 55 was executed.	2-77
9C07	—		BC00	When scanning the fax, white or black correction data for the second side CIS was not within the correct range (second time).	2-77
A000	Image processing was not completed correctly because the number of pixels required for image processing is insufficient in the scanned second side data.	2-73	BD00	A black level not within the standard was scanned when function code 55 was executed.	2-77
A200	The document scanning position sensor detected that the document length was 90 cm or more during the one-side scanning.	2-73	BF00	The document scanning position sensor detected that the document length was 400 mm or longer and could not be fed to ADF (double-side restoration).	2-78
A300	The document scanning position sensor has not detected the document passing even after the document has been fed for the specified time.	2-73	C001	Access request to the server timed out because the server address was wrong, network was not connected, or server was not working.	2-78
A400	The ADF cover sensor detected that the ADF cover was open.	2-74	C002	User authentication error due to wrong user name, wrong password, or date and time was not synchronized between the machine and server.	2-78
A500	When scanning the fax, white or black correction data for the first side CIS unit was not within the correct range (first time).	2-74	C003	Cannot access to the file because the directory name is wrong, writing into directory is not permitted, or writing into file is locked or not permitted.	2-78
A600	When scanning the fax, white or black correction data for the first side CIS unit was not within the correct range (second time).	2-74	C004	Cannot acquire current time which is required for user authentication because the time has not been acquired.	2-78

Error codes	Description	Refer to:	Error codes	Description	Refer to:
C100	Failed to save data to an USB flash memory.	2-78	E400	—	
C700	There is insufficient memory to expand PC print data.	2-79	E500	An error occurred during access to the DRAM in the main PCB ASSY.	2-80
C800	The memory size allotted for Secure Print was exceeded when saving Secure Print data.	2-79	E600	Write error in the EEPROM of the main PCB ASSY	2-80
C900	—		E701	System error in the flash ROM	2-80
CA00	—		E702	Read error in the flash ROM	2-80
D100	An error occurred while initializing the modem.	2-79	E900	An error occurred while initializing the NFC.	2-80
D200	Detected that the modem PCB is not connected.	2-79	EC00	A USB device not within the specification is connected to the USB terminal, resulting in over current.	2-81
D800	An error occurred while initializing the touch panel.	2-79	ED00	Failed to authenticate the firmware for the self test.	2-81
D900	—		EE00	Failed to authenticate the NVRAM for the self test.	2-81
DA00	—		F900	The spec code was not entered correctly.	2-81
DB00	—		FA01	—	
E000	An error occurred in the ROM check sum.	2-80	FA02	—	
E100	Program error	2-80	FA03	—	

3.2 Error Messages

Error message		Description	Error codes	Refer to:
First line	Second line			
Cartridge Error	Put the Toner Cartridge back in.	The new toner sensor could not detect the new toner cartridge correctly.	4F01	2-46
Cooling Down	Wait for a while.	The side thermistor of the fuser unit or internal temperature sensor detected a temperature higher than the specified value.	6801	2-49
Cover is Open	Close the ADF cover.	The ADF cover sensor detected that the ADF cover was open.	A400	2-74
	Close the Back Cover of the Machine.	The eject sensor detected that the fuser cover was open.	6004	2-47
	Close the Front Cover.	The front cover sensor detected that the front cover was open.	6001	2-47
Document Jam	Clear the scanner jam, then press Stop.	The document scanning position sensor detected that the document length was 90 cm or more during the one-side scanning.	A200	2-73
		The document scanning position sensor has not detected the document passing even after the document has been fed for the specified time.	A300	2-73
Drum !	Slide the Green tab on Drum Unit.	Detected discharge that may be attributable to dirty corona wire on the drum unit.	6A00	2-50
Firmware Update	You must update the firmware.	Firmware version of the main PCB is older than that of the TT and LT.	9400	2-71
Ignore Data	Press Stop.	Detected undecodable data during printing. Received undecodable PS data.	---	4.14.1
Jam 2-sided	Pull out the 2-sided Tray at the back of the machine and remove the jammed paper.	The registration front sensor does not detect paper pass within the specified time after the first side was printed in duplex printing mode.	7800	2-62
Jam Inside	Open the Front Cover, pull out the Drum Unit completely and remove the jammed paper.	The eject sensor does not detect paper pass after the registration rear sensor detected the paper pass.	7000	2-51
Jam MP Tray	Remove the jammed paper from MP Tray and press [Retry].	When feeding from the MP tray, the registration rear sensor does not detect paper pass within the specified time after the registration front sensor detected paper pass.	7200	2-52

Error message		Description	Error codes	Refer to:
First line	Second line			
Jam Rear	Open the Back Cover and remove the jammed paper.	The eject sensor remains ON (paper pass detected) even after the registration rear sensor detected the end of paper pass.	7100	2-51
Jam Tray1	Remove the jammed paper from Tray 1.	When printing from the paper tray 1, the registration front sensor does not detect paper pass within the specified time after the paper feed sensor detected paper pass.	7302	2-53
Jam Tray2	Remove the jammed paper from Tray 2.	When printing from the paper tray 2, the registration front sensor or the T2TT jam sensor does not detect paper pass within the specified time after the T2(LT or TT) paper feed sensor detected paper pass.	7402	2-55
Jam Tray3	Remove the jammed paper from Tray 3.	When printing from the paper tray 3, the registration front sensor or the T2/T3TT jam sensor does not detect paper pass within the specified time after the T3(LT or TT) paper feed sensor detected paper pass.	7502	2-57
Jam Tray4	Remove the jammed paper from Tray 4.	When printing from the paper tray 4, the registration front sensor or the T2/T3/T4TT jam sensor does not detect paper pass within the specified time after the T4(LT or TT) paper feed sensor detected paper pass.	7602	2-59
Jam Tray5	Remove the jammed paper from Tray 5.	When printing from the paper tray 5, the registration front sensor or the T2/T3/T4/T5TT jam sensor does not detect paper pass within the specified time after the T5TT paper feed sensor detected paper pass.	7702	2-61

Error message		Description	Error codes	Refer to:
First line	Second line			
Log Access Error	Authentication Error, contact your administrator.	User authentication error due to wrong user name, wrong password, or date and time was not synchronized between the machine and server.	C002	2-78
	File Access Error, contact your administrator.	Cannot access to the file because the directory name is wrong, writing into directory is not permitted, or writing into file is locked or not permitted.	C003	2-78
	Server Timeout, contact your administrator.	Access request to the server timed out because the server address was wrong, network was not connected, or server was not working.	C001	2-78
	Wrong Date & Time, contact your administrator.	Cannot acquire current time which is required for user authentication because the time has not been acquired.	C004	2-78
Machine Error	—	Detected that the modem PCB is not connected.	D200	2-79
Machine Error **	—	A machine error occurred. Refer to error code "****".	---	---
Maintenance	Replace Fuser	The number of printable pages of the fuser unit has reached the upper limit.	4500	2-45
	Replace Laser	The number of printable pages of the laser unit has reached the upper limit.	4600	2-45
	Replace PF Kit MP	Printable pages set for PF kit MP have reached the upper limit.	5001	2-46
	Replace PF Kit 1	Printable pages set for PF kit 1 have reached the upper limit.	5002	2-46
	Replace PF Kit 2	Printable pages set for PF kit 2 have reached the upper limit.	5003	2-46
	Replace PF Kit 3	Printable pages set for PF kit 3 have reached the upper limit.	5004	2-46
	Replace PF Kit 4	Printable pages set for PF kit 4 have reached the upper limit.	5005	2-46
	Replace PF Kit 5	Printable pages set for PF kit 5 have reached the upper limit.	5006	2-46

Error message		Description	Error codes	Refer to:
First line	Second line			
Media Type Mismatch	Reload correct paper in MP Tray, then press [Retry].	When printing from the MP tray, paper type setting in the machine does not match the setting in the driver.	9201	2-68
	Reload correct paper in Tray1, then press [Retry].	When printing from the paper tray 1, paper type setting in the machine does not match the setting in the driver.	9202	2-68
	Reload correct paper in Tray2, then press [Retry].	When printing from the paper tray 2, paper type setting in the machine does not match the setting in the driver.	9203	2-68
	Reload correct paper in Tray3, then press [Retry].	When printing from the paper tray 3, paper type setting in the machine does not match the setting in the driver.	9204	2-68
	Reload correct paper in Tray4, then press [Retry].	When printing from the paper tray 4, paper type setting in the machine does not match the setting in the driver.	9205	2-68
	Reload correct paper in Tray5, then press [Retry].	When printing from the paper tray 5, paper type setting in the machine does not match the setting in the driver.	9206	2-68
No Drum Unit	Open the Front Cover, then install the Drum Unit.	Detected that the drum unit was not set by detecting the GRID terminal current.	6200	2-48
No HUB Support	No HUB Support.	A USB device with a built-in hub is connected.	---	4.14.3

Error message		Description	Error codes	Refer to:
First line	Second line			
No Paper	No Paper T1	Detected that there was no paper set in the paper tray 1 when printing from the paper tray 1.	---	4.2.1
	No Paper T2	Detected that there was no paper set in the paper tray 2 when printing from the paper tray 2.	---	4.2.1
	No Paper T3	Detected that there was no paper set in the paper tray 3 when printing from the paper tray 3.	---	4.2.1
	No Paper T4	Detected that there was no paper set in the paper tray 4 when printing from the paper tray 4.	---	4.2.1
	No Paper T5	Detected that there was no paper set in the paper tray 5 when printing from the paper tray 5.	---	4.2.1
	Reload paper in Tray.	Detected that there was no paper set in all trays when TrayAuto was selected for printing. (At Fax / List printing)	---	4.2.1
		Detected that there was no paper set in all trays when TrayAuto was selected for printing.	9309	2-70
No Paper Fed T1	Reload paper in Tray 1, then press [Retry].	When printing from the paper tray 1, the T1 paper feed sensor does not detect paper pass within the specified time while the T1 paper empty sensor detects some paper set.	7301	2-53
No Paper Fed T2	Reload paper in Tray 2, then press [Retry].	When printing from the paper tray 2, the T2(LT or TT) paper feed sensor does not detect paper pass within the specified time while the T2(LT or TT) paper empty sensor detects some paper set.	7401	2-54
No Paper Fed T3	Reload paper in Tray 3, then press [Retry].	When printing from the paper tray 3, the T3(LT or TT) paper feed sensor does not detect paper pass within the specified time while the T3(LT or TT) paper empty sensor detects some paper set.	7501	2-56
No Paper Fed T4	Reload paper in Tray 4, then press [Retry].	When printing from the paper tray 4, the T4(LT or TT) paper feed sensor does not detect paper pass within the specified time while the T4(LT or TT) paper empty sensor detects some paper set.	7601	2-58

Error message		Description	Error codes	Refer to:
First line	Second line			
No Paper Fed T5	Reload paper in Tray 5, then press [Retry].	When printing from the paper tray 5, the T5TT paper feed sensor does not detect paper pass within the specified time while the T5TT paper empty sensor detects some paper set.	7701	2-60
No Paper MP	Reload paper in MP Tray.	When printing from the MP tray, the MP paper empty sensor detected that there was no paper set in the MP tray. (At Fax / List printing)	---	4.2.4
		When printing from the MP tray, the MP paper empty sensor detected that there was no paper set in the MP tray.	9301	2-69
No Paper T1	Reload paper in Tray 1.	When printing from paper tray 1, the T1 paper empty sensor or the T1 paper feed sensor detected that there was no paper set in paper tray 1. (At Fax / List printing)	---	4.2.1
		When printing from paper tray 1, the T1 paper empty sensor or the T1 paper feed sensor detected that there was no paper set in paper tray 1.	9302	2-69
No Paper T2	Reload paper in Tray 2.	When printing from paper tray 2, the T2(LT or TT) paper empty sensor detected that there was no paper set in paper tray 2. (At Fax / List printing)	---	4.2.1
		When printing from paper tray 2, the T2(LT or TT) paper empty sensor detected that there was no paper set in paper tray 2.	9303	2-69
No Paper T3	Reload paper in Tray 3.	When printing from paper tray 3, the T3(LT or TT) paper empty sensor detected that there was no paper set in paper tray 3. (At Fax / List printing)	---	4.2.1
		When printing from paper tray 3, the T3(LT or TT) paper empty sensor detected that there was no paper set in paper tray 3.	9304	2-69

Error message		Description	Error codes	Refer to:
First line	Second line			
No Paper T4	Reload paper in Tray 4.	When printing from paper tray 4, the T4(LT or TT) paper empty sensor detected that there was no paper set in paper tray 4. (At Fax / List printing)	---	4.2.1
		When printing from paper tray 4, the T4(LT or TT) paper empty sensor detected that there was no paper set in paper tray 4.	9305	2-69
No Paper T5	Reload paper in Tray 5.	When printing from paper tray 5, the T5TT paper empty sensor detected that there was no paper set in paper tray 5. (At Fax / List printing)	---	4.2.1
		When printing from paper tray 5, the T5TT paper empty sensor detected that there was no paper set in paper tray 5.	9306	2-69
No Toner	Open the Front Cover, then install Toner Cartridge.	The toner amount detection sensor detected that the toner cartridge was not set.	6101	2-47
No Tray Attachment	Please install the Tower Tray Attachment Brackets.	When the TT was connected, TT balance sensor L/R wasn't connected properly.	1F00	2-44
No Tray T1	Reinstall Tray.	When printing from paper tray 1 to 5, the T1 paper feed sensor detected open paper tray 1 (before registering printing data to engine).	8501	2-63
		When printing from paper tray 1 to 5, the T1 paper feed sensor detected open paper tray 1 (after registering printing data to engine).	8505	2-64
No Tray T2	Reinstall Tray 2.	When printing from paper tray 2 to 5, the T2(LT or TT) paper feed sensor detected open paper tray 2 (before registering printing data to engine).	8502	2-63
		When printing from paper tray 2 to 5, the T2(LT or TT) paper feed sensor detected open paper tray 2 (after registering printing data to engine).	8506	2-64

Error message		Description	Error codes	Refer to:
First line	Second line			
No Tray T3	Reinstall Tray 3.	When printing from paper tray 3 to 5, the T3(LT or TT) paper feed sensor detected open paper tray 3 (before registering printing data to engine).	8503	2-63
		When printing from paper tray 3 to 5, the T3(LT or TT) paper feed sensor detected open paper tray 3 (after registering printing data to engine).	8507	2-64
No Tray T4	Reinstall Tray 4.	When printing from paper tray 4 to 5, the T4(LT or TT) paper feed sensor detected open paper tray 4 (before registering printing data to engine).	8504	2-63
		When printing from paper tray 4 to 5, the T4(LT or TT) paper feed sensor detected open paper tray 4 (after registering printing data to engine).	8508	2-64
Out of Memory	Press Stop[x].	There is insufficient memory to expand PC print data.	C700	2-79
Output Tray Full	Remove the paper from the Standard Output Tray.	Machine stack sensor detected the eject paper full state at the start of printing when the machine output tray was selected as the output tray.	8702	2-64
Paper Low	Paper Low T1	Tray1 paper level is low.	---	4.14.4
	Paper Low T2	Tray2 paper level is low.	---	4.14.4
	Paper Low T3	Tray3 paper level is low.	---	4.14.4
	Paper Low T4	Tray4 paper level is low.	---	4.14.4
	Paper Low T5	Tray5 paper level is low.	---	4.14.4
Print Data Full	Print Data is full. Press Stop[x] Key and delete the previously stored data.	The memory size allotted for Secure Print was exceeded when saving Secure Print data.	C800	2-79
Print Unable ZC	Turn the power off and then back on again.	Detected irregular power supply for less than 100 times.	6F00	2-50
Print Unable **	Turn the power off and then back on again.	Printing related error. Refer to error code "***".	---	---

Error message		Description	Error codes	Refer to:
First line	Second line			
Received Fax XX	Set the appropriate paper in except Tray 2.	Only T2 tray is set for A4 / Letter / Legal / Folio but T2 is set as "Skip Tray".	9B03	2-72
	Set the appropriate paper in except Tray 3.	Only T3 tray is set for A4 / Letter / Legal / Folio but T3 is set as "Skip Tray".	9B04	2-72
	Set the appropriate paper in except Tray 4.	Only T4 tray is set for A4 / Letter / Legal / Folio but T4 is set as "Skip Tray".	9B05	2-72
	Set the appropriate paper in except Tray 5.	Only T5 tray is set for A4 / Letter / Legal / Folio but T5 is set as "Skip Tray".	9B06	2-72
Replace Toner	Open the Front Cover, replace Toner Cartridge.	Dot counter or develop roller counter of the toner has reached the upper limit.	4C01	2-45
Scan Unable	Document is too long for 2-sided scanning. Press Stop[x].	The first side document scanning position sensor detected that the document length was 400 mm or longer and could not be fed to ADF (double-side restoration).	BF00	2-78
	Remove the original document. Turn the power off, then on again.	Image processing was not completed correctly because the number of pixels required for image processing is insufficient in the scanned second side data.	A000	2-73
		Image processing cannot be completed correctly because the number of pixels required for image processing is insufficient in the scanned first side data.	AD00	2-75
Scan Unable **	Turn the power off and then back on again.	A machine error occurred. Refer to the error code "***".	---	---
Scanner Error **	—	A white level not within the standard was scanned when function code 55 was executed.	BB00	2-77
		A black level not within the standard was scanned when function code 55 was executed.	BD00	2-77

Error message		Description	Error codes	Refer to:
First line	Second line			
Self-Diagnostic	Turn the power off, then on again. Leave the machine for 15 min.	An error occurred in the fuser unit when the power switch was turned ON or sleep mode was released.	6901	2-49
	Will automatically restart within 15 minutes.	Rechecking the error after the power switch was turned OFF and then ON again because an error was detected in the fuser unit. (This message is displayed for approximately 15 minutes when the machine is restarted after error code 6901 has occurred.)	6902	2-49
Service Error XX	Please contact service engineer.	Failed to authenticate the firmware for the self test.	ED00	2-81
		Failed to authenticate the NVRAM for the self test.	EE00	2-81
Size Error	Specify the correct paper size for Tray1.	When printing from paper tray 1, a paper size not supported for paper tray 1 was specified from the driver.	9702	2-72
	Specify the correct paper size for Tray2.	When printing from paper tray 2, a paper size not supported for paper tray 2 was specified from the driver.	9703	2-72
	Specify the correct paper size for Tray3.	When printing from paper tray 3, a paper size not supported for paper tray 3 was specified from the driver.	9704	2-72
	Specify the correct paper size for Tray4.	When printing from paper tray 4, a paper size not supported for paper tray 4 was specified from the driver.	9705	2-72
	Specify the correct paper size for Tray5.	When printing from paper tray 5, a paper size not supported for paper tray 5 was specified from the driver.	9706	2-72
Size Error 2-sided	Press [OK]. Specify the correct paper and load the same size paper as the Printer driver setting.	A tray set to duplex printing-incompatible size was specified in duplex printing.	9701	2-72
	Specify the correct paper.	The registration rear sensor detected that the paper fed was smaller or larger than the specified size in duplex printing mode.	8A01	2-65

Error message		Description	Error codes	Refer to:
First line	Second line			
Size Mismatch	Reload correct paper.	Detected that the size of paper set in the paper tray was over 10 mm shorter than letter size during receiving fax data or printing a list or report.	8E02	2-66
	Reload correct paper in MP Tray, then press [Retry].	When printing from the MP tray, the size of paper set in the MP tray does not match the size specified by the driver.	9001	2-67
	Reload correct paper in Tray1, then press [Retry].	When printing from the paper tray 1, the size of paper set in the paper tray 1 does not match the size specified by the driver.	9002	2-67
	Reload correct paper in Tray2, then press [Retry].	When printing from the paper tray 2, the size of paper set in the paper tray 2 does not match the size specified by the driver.	9003	2-67
	Reload correct paper in Tray3, then press [Retry].	When printing from the paper tray 3, the size of paper set in the paper tray 3 does not match the size specified by the driver.	9004	2-67
	Reload correct paper in Tray4, then press [Retry].	When printing from the paper tray 4, the size of paper set in the paper tray 4 does not match the size specified by the driver.	9005	2-67
	Reload correct paper in Tray5, then press [Retry].	When printing from the paper tray 5, the size of paper set in the paper tray 5 does not match the size specified by the driver.	9006	2-67
Supplies	Toner Low	Dot counter or develop roller counter of the toner is reaching the upper limit.	4B01	2-45
	Drum End Soon.	The number of rotations of the drum unit is reaching the upper limit.	4000	2-44
	Replace Drum	The number of rotations of the drum unit has reached the upper limit. (Printing does not stop.)	4200	2-44
Too Many Trays	Turn the power off and remove additional trays.	Detected more LTs than connectible limit.	6D00	2-50
Touchscreen initialization failed	Remove any material which is on the touchscreen.	An error occurred while initializing the touch panel.	D800	2-79
Unable to Update:**	Check the firmware update file and try again.	Cannot execute USB Memory Firm UPDATE.	---	4.14.2

Error message		Description	Error codes	Refer to:
First line	Second line			
Unusable Device	Remove the Device. Turn the power off and back on again.	A USB device not within the specification is connected to the USB terminal, resulting in over current.	EC00	2-81
	—	The connected USB device is not supported.	---	4.14.3
USB Device Error	Only insert one USB device at a time.	When the power switch was ON, multiple USB flash memories are connected to the USB host.	---	4.14.3
Wrong Paper Size T1	Reload correct paper in Tray 1 or press [Retry].	When printing from the paper tray 1, the size of paper set in the paper tray 1 does not match the size specified by the driver.	---	4.14.1
Wrong Paper Size T2	Reload correct paper in Tray 2 or press [Retry].	When printing from the paper tray 2, the size of paper set in the paper tray 2 does not match the size specified by the driver.	---	4.14.1
Wrong Paper Size T3	Reload correct paper in Tray 3 or press [Retry].	When printing from the paper tray 3, the size of paper set in the paper tray 3 does not match the size specified by the driver.	---	4.14.1
Wrong Paper Size T4	Reload correct paper in Tray 4 or press [Retry].	When printing from the paper tray 4, the size of paper set in the paper tray 4 does not match the size specified by the driver.	---	4.14.1
Wrong Paper Size T5	Reload correct paper in Tray 5 or press [Retry].	When printing from the paper tray 5, the size of paper set in the paper tray 5 does not match the size specified by the driver.	---	4.14.1
Wrong Paper Size MP	Reload correct paper in MP Tray or press [Retry].	When printing from the MP tray, the size of paper set in the MP tray does not match the size specified by the driver.	---	4.14.1
2-sided Disabled	Close the Back Cover and put the 2-sided Tray back in.	The back cover/duplex tray sensor detected that the cover was open when duplex printing is started. (Before registering printing data to engine)	8903	2-65
		The back cover/duplex tray sensor detected that the cover was open during duplex printing. (After registering printing data to engine)	8904	2-65

3.3 Communication Errors

How to print the communication error list (Communication List) can be found in [“2.1 Print Communication Error List”](#) in Chapter 5.

Code 1	Code 2	Cause	Refer to:
10	07	No document set when calling.	2-123
10	08	Wrong fax number called.	2-123
11	01	No dial tone detected before dialing.	2-123
11	02	Busy tone detected before dialing.	2-123
11	03	2nd dial tone not detected.	2-123
11	05	No loop current detected.	2-123
11	06	Busy tone detected after dialing or receiving a call.	2-123
11	07	No response from the receiver in sending.	2-123
11	08	No response from the remote station in sending Session Initiation Protocol (SIP).	2-123
11	10	No tone detected after dialing.	2-123
11	11	No acknowledgement returned after Fax2 net command was sent.	2-123
13	12	Error signal received after Fax2 net command was sent.	2-123
16	09	No Cipher registration	2-123
17	01	Called using a dial number that cannot be used for the NGN line (33 digits or longer or non numeric characters).	2-123
17	07	No response from the caller in receiving.	2-123
1C	01	Detected that access to the NGN line was not authorized. (T38: 403 Forbidden)	2-123
1C	02	No file or folder (directory) found as a result of search via the NGN line. (T38: 404 Not Found)	2-123
1C	03	Remote station does not support the NGN line. (T38: 488 Not Acceptable Here)	2-123
1C	04	SIP (Session Initiation Protocol) connection not possible. (T38) USW NGN fax setting is OFF or calling attempted before acquisition of SIP information.	2-123
1C	05	Internal error detected in the communication network. (T38)	2-123
1C	06	SIP Server timeout (T38)	2-123
1C	08	An error other than 1C01,1C02,1C03,1C04,1C06,1D01,1D02 or 1D04 was detected.	2-123
1D	01	Detected that the NGN line was busy. (T38: 486 Busy)	2-123
1D	02	Detected that the NGN line was temporarily unavailable. (T38: 480 Temporarily Unavailable)	2-123
1D	04	Network cable not connected (Link Down detected) or not connected to the Network. (T38)	2-123

Code 1	Code 2	Cause	Refer to:
20	01	Unable to detect flag field.	2-123
20	02	Carrier was OFF for 200 ms or longer.	2-123
20	03	Abort detected ("1" in succession for 7 bits or more).	2-123
20	04	Overrun detected.	2-123
20	05	A frame received for 3 seconds or more.	2-123
20	06	CRC error in answerback.	2-123
20	07	Echo command received.	2-123
20	08	Invalid command received.	2-123
20	09	Command ignored in document setting or damping-out at turn-around transmission.	2-123
20	0A	T5 time-out error	2-123
20	0B	CRP received.	2-123
20	0C	EOR or NULL received.	2-123
20	0D	Corresponding command not received although the FIF command sending bit is ON.	2-123
20	0E	EOR command received.	2-123
20	13	Line disconnected without receiving DCN after receiving the last page. (After receiving EOP and sending CFR, received BYE before receiving DCN.) (T38)	2-123
32	01	Remote terminal only with V.29 capability in 2,400 or 4,800 bps transmission.	2-123
32	02	Remote terminal not ready for polling.	2-123
32	10	Remote terminal not equipped with password function or its password switch is OFF.	2-123
32	11	Remote terminal not equipped with or not ready for confidential mailbox function.	2-123
32	12	Remote terminal not equipped with or not ready for relay broadcasting function.	2-123
32	13	No confidential mail in the remote terminal.	2-123
32	14	Available memory space of the remote terminal is less than that required for reception of confidential mails or relay broad-casting instruction.	2-123
32	15	Remote terminal not equipped with Cipher receiving function.	2-123
32	16	Remote terminal not equipped with SEP function.	2-123
32	17	Remote terminal not equipped with SUB function.	2-123
32	18	Remote terminal not equipped with color function.	2-123
40	02	Illegal coding system requested.	2-123
40	03	Illegal recording width requested.	2-123

Code 1	Code 2	Cause	Refer to:
40	05	ECM requested although not allowed.	2-123
40	06	Polled while not ready.	2-123
40	07	No document to be sent when polled.	2-123
40	10	Nation code or manufacturer code not correct.	2-123
40	11	Group number not registered for relay broad-casting was specified or the number of addressees specified exceeded the maximum allowable number.	2-123
40	12	Retrieval attempted while not ready for retrieval.	2-123
40	13	Polled by any other manufacturers' terminal while waiting for secure polling.	2-123
40	14	Common key not registered although it needs to be used.	2-123
40	15	Black / Red data reception is requested when Black / Red receiving function is disabled.	2-123
40	16	Cipher transmission is requested when Cipher receiving function is disabled.	2-123
40	17	Invalid resolution selected.	2-123
40	20	Invalid full color mode selected.	2-123
50	01	Vertical resolution capability changed after compensation of background color.	2-123
63	01	"Password + last 4 digits of telephone number" does not match.	2-123
63	02	Password not correct	2-123
63	03	Polling ID not correct	2-123
63	04	Specified confidential ID and MailBox ID do not match.	2-123
63	05	Relay broad-casting ID not correct	2-123
63	06	Specified Retrieval ID and MailBox Retrieval ID do not match.	2-123
63	07	Select receiving ID not correct	2-123
63	08	Cipher Key not correct	2-123
74	XX	DCN received	2-123
80	01	Fallback impossible.	2-123
90	01	Unable to detect video signals or commands within 6 seconds after CFR is transmitted.	2-123
90	02	Received PPS containing invalid page count or block count.	2-123
A0	03	Error correction sequence not terminated even at final transmission speed after fallback.	2-123
A0	11	Receive buffer empty (5-second time-out)	2-123
A0	12	Receive buffer full during operation except receiving into memory.	2-123
A0	13	Decoding error continued on 500 lines or more.	2-123
A0	14	Decoding error continued for 15 seconds or more.	2-123

Code 1	Code 2	Cause	Refer to:
A0	15	Time-out: 13 seconds or more for one-line transmission.	2-123
A0	16	RTC not found or carrier OFF detected for 6 seconds.	2-123
A0	17	RTC found but no command detected for 60 seconds or longer.	2-123
A0	19	No video data to be sent.	2-123
A0	20	Cannot continue receiving color fax (remaining ink low).	2-123
A8	01	RTN, PIN, or ERR received (sending terminal).	2-123
A9	01	RTN, PIN, or ERR sent (receiving terminal).	2-123
AA	18	Receive buffer full during receiving data into memory.	2-123
B0	01	Polarity reversion detected.	2-123
B0	02	Unable to receive the next-page data.	2-123
B0	03	Unable to receive polling during turn-around transmission due to call reservation.	2-123
B0	04	PC interface error	2-123
C0	01	No common modulation mode or failed to poll.	2-123
C0	02	Unable to detect JM.	2-123
C0	03	Unable to detect CM.	2-123
C0	04	Unable to detect CJ.	2-123
C0	10	Cannot finish V. 34 negotiation or training.	2-123
C0	11	Modem error detected during V. 34 negotiation or training.	2-123
C0	20	Modem error detected while sending commands.	2-123
C0	21	Modem error detected while receiving commands.	2-123
C0	22	Control channel connection time-out.	2-123
C0	30	Modem error detected while sending video signals.	2-123
C0	31	Modem error detected while receiving video signals.	2-123
E0	01	Failed to detect 1,300 Hz signal in burn-in operation.	2-123
E0	02	Failed to detect PB signals in burn-in operation.	2-123
E0	03	Unable to detect commands in burn-in operation when RS232C is used.	2-123

4. TROUBLESHOOTING

4.1 Error Cause and Remedy

■ Error code 0102

Communication error between the engine ASIC and motor driver or faulty motor driver.

Step	Cause	Remedy
1	Connection failure of the paper feed motor harness	Reconnect the paper feed motor harness.
2	Paper feed motor failure	Replace the paper feed motor.
3	Main PCB failure	Replace the main PCB ASSY.

■ Error code 0201

Cannot detect the synchronized signal of the paper feed motor. The speed of the paper feed motor does not stabilize within the specified time.

Step	Cause	Remedy
1	Connection failure of the paper feed motor harness	Reconnect the paper feed motor harness.
2	Damaged fuser gear	Replace the fuser gear.
3	Paper feed motor failure	Replace the paper feed motor.
4	Damaged fuser unit	Replace the fuser unit.
5	Low-voltage power supply PCB failure	Replace the low-voltage power supply PCB ASSY.
6	Damaged part in drive sub ASSY	Replace the main frame L ASSY.
7	Main PCB failure	Replace the main PCB ASSY.

■ Error code 0203

Eject motor failure was detected.

Step	Cause	Remedy
1	Connection failure of the eject motor harness	Reconnect the eject motor harness.
2	Eject motor failure	Replace the eject motor.
3	Low-voltage power supply PCB failure	Replace the low-voltage power supply PCB ASSY.
4	Damaged part in eject gears	Replace the main frame L ASSY.
5	Main PCB failure	Replace the main PCB ASSY.

■ **Error code 0300**

Cannot detect the lock signal of the polygon motor for the laser unit (second time).

Error code 0305

Cannot detect the lock signal of the polygon motor for the laser unit (first time).

Error code 0401

Cannot detect the synchronized signal of the polygon motor for the laser unit (second time).

Error code 0405

Cannot detect the synchronized signal of the polygon motor for the laser unit (first time).

Step	Cause	Remedy
1	Connection failure of the laser unit flat cable	Reconnect the laser unit flat cable.
2	Laser unit flat cable failure	Replace the laser unit flat cable.
3	Laser unit failure	Replace the laser unit.
4	Main PCB failure	Replace the main PCB ASSY.

■ **Error code 0501**

The center thermistor of the fuser unit has not reached the specified temperature within the specified time.

Error code 0502

The center thermistor of the fuser unit has not reached the specified temperature within the specified time after it was heated normally to the certain level.

Error code 0503

The center thermistor of the fuser unit detected a temperature higher than the specified value.

Error code 0504

After the heat unit was heated normally, the center thermistor of the fuser unit detected a temperature lower than the specified value.

Error code 0505

The center thermistor of the fuser unit detected a temperature rise greater than the specified value within the specified time.

Error code 0506

The center thermistor of the fuser unit detected a temperature fall greater than the specified value within the specified time.

Error code 0508

The side thermistor of the fuser unit did not detect a temperature rise when the heater was ON.

<User Check>

- Turn OFF the power switch. After several seconds, turn ON the power again and check that this error is reset.

Step	Cause	Remedy
1	Connection failure of the center or side thermistor harness of the fuser unit	Reconnect the center or side thermistor harness of the fuser unit.
2	Connection failure of the fuser unit heater harness	Reconnect the fuser unit heater harness.
3	Connection failure of the eject sensor harness	Reconnect the eject sensor harness.
4	Connection failure of the low-voltage power supply harness	Reconnect the low-voltage power supply harness.
5	Eject sensor PCB failure	Replace the eject sensor PCB ASSY.
6	Fuser unit failure	Replace the fuser unit.
7	Low-voltage power supply PCB failure	Replace the low-voltage power supply PCB ASSY.
8	Main PCB failure	Replace the main PCB ASSY.

■ **Error code 050A**

The hardware detected a temperature error through the center thermistor or the side thermistor of the fuser unit.

Error code 050B

When the center thermistor of the fuser unit was lower than the idle temperature, the side thermistor detected a temperature higher than the specified temperature.

Error code 050C

When the center thermistor of the fuser unit was higher than the idle temperature, the side thermistor detected a temperature lower than the specified temperature.

<User Check>

- Turn OFF the power switch. After several seconds, turn ON the power again and check that this error is reset.

Step	Cause	Remedy
1	Connection failure of the center or side thermistor harness of the fuser unit	Reconnect the center or side thermistor harness of the fuser unit.
2	Connection failure of the fuser unit heater harness	Reconnect the fuser unit heater harness.
3	Connection failure of the eject sensor harness	Reconnect the eject sensor harness.
4	Connection failure of the low-voltage power supply harness	Reconnect the low-voltage power supply harness.
5	Eject sensor PCB failure	Replace the eject sensor PCB ASSY.
6	Fuser unit failure	Replace the fuser unit.
7	Low-voltage power supply PCB failure	Replace the low-voltage power supply PCB ASSY.
8	Main PCB failure	Replace the main PCB ASSY.

■ **Error code 0800**

An error occurred in the internal temperature sensor.

Step	Cause	Remedy
1	Connection failure of the internal temperature sensor harness	Reconnect the internal temperature sensor harness.
2	Internal temperature sensor failure	Replace the main frame L ASSY.
3	Main PCB failure	Replace the main PCB ASSY.

■ Error code 0900

Detected irregular power supply for more than 100 times.

<User Check>

- Turn OFF the power switch. After several seconds, turn ON the power again and check that this error is reset.

Step	Cause	Remedy
1	Low-voltage power supply PCB failure	Replace the low-voltage power supply PCB ASSY. Refer to "1.3.31 Reset counters for consumable parts (function code: 88)" in Chapter 5 to reset the irregular power supply detection counter after the replacement.
2	Main PCB failure	Replace the main PCB ASSY.

Note:

- The irregular power supply detection error of the low-voltage power supply PCB (error code: 0900) occurs when there is a large distortion in the power supply voltage supplied to the machine. In this case, if the same power supply is used, the same error may occur even when the low-voltage power supply PCB ASSY is replaced. Ask the user to review the installation environment.
- Do not reset the power supply PCB counter before replacing it with a new one. It may cause fire.

■ Error code 0A02

Detected a main fan failure.

Step	Cause	Remedy
1	Connection failure of the main fan harness	Reconnect the main fan harness.
2	Connection failure of the toner amount detection sensor PCB harness (light emission)	Reconnect the toner amount detection sensor PCB harness (light emission).
3	Main fan failure	Replace the main fan.
4	Low-voltage power supply PCB failure	Replace the low-voltage power supply PCB ASSY.
5	Toner amount detection sensor PCB (light emission) failure	Replace the toner amount detection sensor PCB ASSY (light emission).
6	Main PCB failure	Replace the main PCB ASSY.

■ Error code 0B01

An error occurred in the high-voltage power supply PCB ASSY while operating.

Error code 0B02

An error occurred in the high-voltage power supply PCB ASSY when the machine was in the ready state.

<User Check>

- Replace the drum unit. (corona wire breakage)

Step	Cause	Remedy
1	Connection failure of the HVPS flat cable	Reconnect the HVPS flat cable.
2	High-voltage power supply PCB failure	Replace the high-voltage power supply PCB ASSY.
3	Main PCB failure	Replace the main PCB ASSY.

■ **Error code 1701**

Detected a TT fan failure.

Step	Cause	Remedy
1	Malfunction of the TT control PCB	Install the latest main firmware.
2	Connection failure of the TT fan harness	Reconnect the TT fan harness.
3	LT/TT connector failure (machine side or TT side)	Replace the LT/TT connector of the machine side or TT side.
4	TT fan failure	Replace the TT fan.
5	TT control PCB failure	Replace the TT control PCB.
6	Main PCB failure	Replace the main PCB ASSY.

■ **Error code 1801**

A communication error occurred between the ASIC and T2LT control PCB in the engine. (LT only)

Error code 1802

A communication error occurred between the ASIC and T3LT control PCB ASSY in the engine. (LT only)

Step	Cause	Remedy
1	Malfunction of the LT control PCB	Install the latest main firmware.
2	An LT/TT connector failure (machine side or LT side)	Replace the appropriate LT/TT connector of the machine side or LT side.
3	An LT control PCB failure	Replace the appropriate LT control PCB.
4	Main PCB failure	Replace the main PCB ASSY.

■ **Error code 1808**

A communication error occurred between the ASIC and TT control PCB in the engine.

Step	Cause	Remedy
1	Malfunction of the TT control PCB	Install the latest main firmware.
2	LT/TT connector failure (machine or TT side)	Replace the LT/TT connector on the machine side or TT side.
3	TT control PCB failure	Replace the TT control PCB.
4	Main PCB failure	Replace the main PCB ASSY.

■ **Error code 1901**

Detected a TT motor failure.

Step	Cause	Remedy
1	Malfunction of the TT control PCB	Install the latest main firmware.
2	Connection failure of the TT motor harness	Reconnect the TT motor harness.
3	LT/TT connector failure (machine side or TT side)	Replace the LT/TT connector of the machine side or TT side.
4	TT motor failure	Replace the TT motor.
5	TT control PCB failure	Replace the TT control PCB.
6	Main PCB failure	Replace the main PCB ASSY.

■ **Error code 1F00**

When the TT was connected, TT balance sensor L/R wasn't connected properly.

Step	Cause	Remedy
1	Connection failure of the TT balance sensor L/R harness.	Reconnect the TT balance sensor L/R harness or relay connector harness.
2	TT balance sensor L/R attachment failure	Reattach the TT balance sensor L/R.
3	LT/TT connector failure (machine side or TT side)	Replace the LT/TT connector of the machine side or TT side.
4	TT balance sensor L/R failure	Replace the TT balance sensor L/R.
5	TT control PCB failure	Replace the TT control PCB ASSY.
6	Main PCB failure	Replace the main PCB ASSY.

■ **Error code 3801**

A temperature error occurred in the external temperature/humidity sensor.

Step	Cause	Remedy
1	Connection failure of the external temperature/humidity sensor harness	Reconnect the external temperature/humidity sensor harness.
2	External temperature/humidity sensor failure	Replace the main frame L ASSY.
3	Main PCB failure	Replace the main PCB ASSY.

■ **Error code 4000**

The number of rotations of the drum unit is reaching the upper limit.

Error code 4200

The number of rotations of the drum unit has reached the upper limit. (Printing does not stop.)

Step	Cause	Remedy
1	Replace the drum unit with a new one and reset the drum counter. If the error display is not cleared, the main PCB is faulty.	Replace the main PCB ASSY.

■ **Error code 4500**

The number of printable pages of the fuser unit has reached the upper limit.

Step	Cause	Remedy
1	End of life of the fuser unit	Replace the fuser unit. Refer to "1.3.31 Reset counters for consumable parts (function code: 88)" in Chapter 5 to reset the fuser unit counter after the replacement.
2	Replace the fuser unit with a new one and reset the fuser unit counter. If the error display is not cleared, the main PCB is faulty.	Replace the main PCB ASSY.

■ **Error code 4600**

The number of printable pages of the laser unit has reached the upper limit.

Step	Cause	Remedy
1	End of life of the laser unit	Replace the laser unit. Refer to "1.3.31 Reset counters for consumable parts (function code: 88)" in Chapter 5 to reset the laser unit counter after the replacement.
2	Replace the laser unit with a new one and reset the laser unit counter. If the error display is not cleared, the main PCB is faulty.	Replace the main PCB ASSY.

■ **Error code 4B01**

Dot counter or develop roller counter of the toner is reaching the upper limit.

Error code 4C01

Dot counter or develop roller counter of the toner has reached the upper limit.

Step	Cause	Remedy
1	Replace the toner cartridge with a new one. If the error display is not cleared, the main PCB is faulty.	Replace the main PCB ASSY.

■ **Error code 4F01**

The new toner sensor could not detect the new toner cartridge correctly.

<User Check>

- If the machine is on the uneven surface, place it on a level surface.

Step	Cause	Remedy
1	Connection failure of the relay front harness	Reconnect the relay front harness.
2	New toner actuator coming off or caught in some sections of the machine	Reattach the new toner actuator.
3	Develop joint coming off or caught in some sections of the machine	Reattach the develop joint.
4	New toner sensor failure	Replace the relay front PCB ASSY.
5	Paper feed drive gears failure	Replace the main frame L ASSY.
6	If the error display is not cleared after replacing the toner cartridge with a new one again, the main PCB is faulty.	Replace the main PCB ASSY.

■ **Error code 5001**

Printable pages set for PF kit MP have reached the upper limit.

Error code 5002

Printable pages set for PF kit 1 have reached the upper limit.

Error code 5003

Printable pages set for PF kit 2 have reached the upper limit.

Error code 5004

Printable pages set for PF kit 3 have reached the upper limit.

Error code 5005

Printable pages set for PF kit 4 have reached the upper limit.

Error code 5006

Printable pages set for PF kit 5 have reached the upper limit.

Step	Cause	Remedy
1	End of life of the applicable PF kit	Replace the applicable PF kit. Refer to "1.3.31 Reset counters for consumable parts (function code: 88)" in Chapter 5 to reset the applicable PF kit counter after the replacement.
2	If the error display is not cleared after the applicable PF kit counter has been reset, the main PCB is faulty.	Replace the main PCB ASSY.

■ **Error code 6001**

The front cover sensor detected that the front cover was open.

<User Check>

- Close the front cover.

Step	Cause	Remedy
1	Connection failure of the front cover sensor harness	Reconnect the front cover sensor harness.
2	Connection failure of the relay front harness	Reconnect the relay front harness.
3	Front cover sensor attachment failure	Reattach the front cover sensor.
4	Front cover failure	Replace the front cover.
5	Front cover sensor failure	Replace the relay front PCB ASSY.
6	Relay front PCB failure	Replace the relay front PCB ASSY.
7	Main PCB failure	Replace the main PCB ASSY.

■ **Error code 6004**

The eject sensor detected that the fuser cover was open.

<User Check>

- Close the fuser cover.

Step	Cause	Remedy
1	Eject actuator coming off or caught in some sections of the machine	Reattach the eject actuator.
2	Fuser cover attachment failure	Reattach the fuser cover.
3	Connection failure of the eject sensor harness	Reconnect the eject sensor harness.
4	Eject sensor PCB failure	Replace the eject sensor PCB ASSY.
5	Main PCB failure	Replace the main PCB ASSY.

■ **Error code 6101**

The toner amount detection sensor detected that the toner cartridge was not set.

<User Check>

- Set the toner cartridge correctly.

Step	Cause	Remedy
1	Toner amount detection sensor PCB (light reception) failure	Replace the toner amount detection sensor PCB ASSY (light reception).
2	Relay front PCB failure	Replace the relay front PCB ASSY.
3	Main PCB failure	Replace the main PCB ASSY.

■ **Error code 6200**

Detected that the drum unit was not set by detecting the GRID terminal current.

<User Check>

- Set the drum unit correctly.

Step	Cause	Remedy
1	Dirt on the GRID terminals of the drum unit and those of the machine	Clean the CHG and GRID terminals of the drum unit and those of the machine. (Refer to Fig. 2-8 and Fig. 2-9.)
2	Dirt on the high-voltage power supply PCB terminal	Clean the high-voltage power supply PCB terminal.
3	high-voltage power supply PCB failure	Replace the high-voltage power supply PCB ASSY.
4	Main PCB failure	Replace the main PCB ASSY.

■ **Electrodes location of the toner cartridge and drum unit**

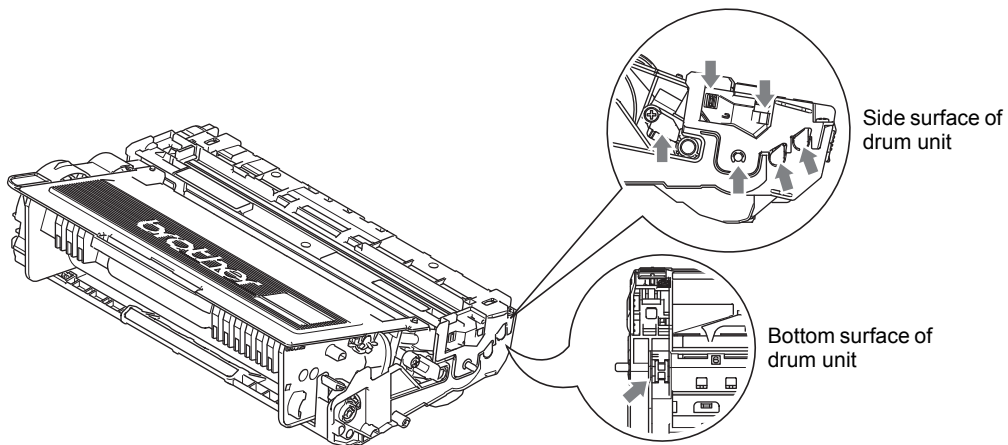

Fig. 2-8

■ **Electrodes location of the machine**

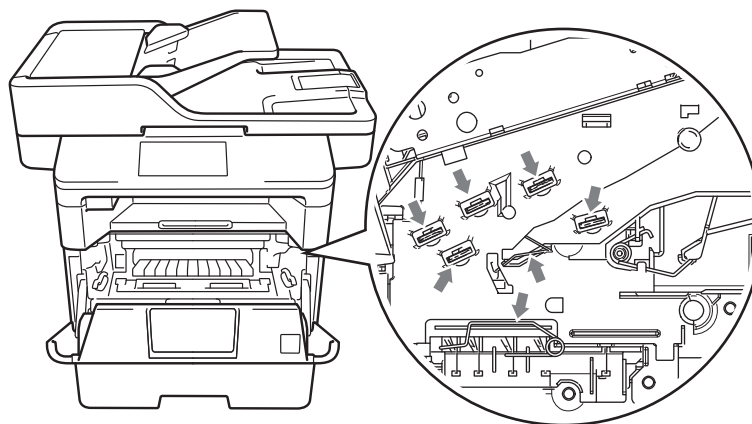

Fig. 2-9

■ **Error code 6801**

The side thermistor of the fuser unit or internal temperature sensor detected a temperature higher than the specified value.

<User Check>

- Lower the room temperature.
- Keep the machine away from heating appliances.

Step	Cause	Remedy
1	Connection failure of the internal temperature sensor harness	Reconnect the internal temperature sensor harness.
2	Internal temperature sensor failure	Replace the main frame L ASSY.
3	Fuser unit side thermistor failure	Replace the fuser unit.
4	Main PCB failure	Replace the main PCB ASSY.

■ **Error code 6901**

An error occurred in the fuser unit when the power switch was turned ON or sleep mode was released.

Error code 6902

Rechecking the error after the power switch was turned OFF and then ON again because an error was detected in the fuser unit.

(This message is displayed for approximately 15 minutes when the machine is restarted after error code 6901 has occurred.)

Step	Cause	Remedy
1	Connection failure of a fuser unit harness	Reconnect the fuser unit harness.
2	Connection failure of the eject sensor harness	Reconnect the eject sensor harness.
3	Eject sensor PCB failure	Replace the eject sensor PCB ASSY.
4	Fuser unit failure	Replace the fuser unit.
5	Low-voltage power supply PCB failure	Replace the low-voltage power supply PCB ASSY.
6	Main PCB failure	Replace the main PCB ASSY.

Note:

- Turn OFF the power switch. After the fuser unit has cooled sufficiently, turn ON the power switch again and leave the machine for 15 minutes. This problem may then be cleared.
- To release the fuser unit error after taking appropriate measures, enter the maintenance mode once and quit it with the function code 99.

■ **Error code 6A00**

Detected discharge that may be attributable to dirty corona wire on the drum unit.

<User Check>

- Slide the green tab of the drum unit to left and right for two to three times to clean the corona wire.
- Clean the electrode of the drum unit.
- Replace the drum unit.

Step	Cause	Remedy
1	Dirt on the high-voltage power supply PCB terminal	Clean the electrodes of the machine. (Refer to Fig. 2-9.)
2	High-voltage power supply PCB attachment failure	Check if each electrode comes back smoothly after pressing it. If not, reattach each electrode.
3	High-voltage power supply PCB failure	Replace the high-voltage power supply PCB ASSY.
4	Main PCB failure	Replace the main PCB ASSY.

■ **Error code 6D00**

Detected more LTs than connectible limit.

<User Check>

- Reduce LTs to acceptable numbers.
- Reconnect LTs.

Step	Cause	Remedy
1	Dust around the LT/TT connector	Clean the LT/TT connector.
2	Malfunction of the LT control PCB	Install the latest main firmware.
3	Machine or LT/TT connector failure	Replace the machine or LT/TT connector.
4	LT control PCB failure	Replace a LT control PCB ASSY.
5	Main PCB failure	Replace the main PCB ASSY.

■ **Error code 6F00**

Detected irregular power supply for less than 100 times.

<User Check>

- Turn the power switch OFF and then back ON again.
- Use a noise filter on the power supply.
- Install a voltage stabilizer to the power supply unit.

■ **Error code 7000**

The eject sensor does not detect paper pass after the registration rear sensor detected the paper pass.

<User Check>

- Remove the jammed paper.
- Replace the drum unit with a new one.

Step	Cause	Remedy
1	Foreign object inside the machine	Remove the foreign object.
2	Connection failure of the eject sensor harness	Reconnect the eject sensor harness.
3	Eject actuator coming off or caught in some sections of the machine	Reattach the eject actuator.
4	Fuser cover attachment failure	Reattach the fuser cover.
5	Eject sensor failure	Replace the eject sensor PCB ASSY.
6	high-voltage power supply PCB failure	Replace the high-voltage power supply PCB ASSY.
7	Fuser unit failure	Replace the fuser unit.
8	Damaged fuser gears or drum gears	Replace the main frame L ASSY.
9	Main PCB failure	Replace the main PCB ASSY.

■ **Error code 7100**

The eject sensor remains ON (paper pass detected) even after the registration rear sensor detected the end of paper pass.

<User Check>

- Remove the jammed paper.
- Check if the back cover is open during duplex printing.

Step	Cause	Remedy
1	Foreign object in the rear of the machine	Remove the foreign object.
2	Eject actuator caught in some sections of the machine	Reattach the eject actuator.
3	Fuser cover attachment failure	Reattach the fuser cover.
4	Eject sensor failure	Replace the eject sensor PCB ASSY.
5	high-voltage power supply PCB failure	Replace the high-voltage power supply PCB ASSY.
6	Fuser cover failure	Replace the fuser cover.
7	Damaged eject roller 1 drive gears	Replace the main frame L ASSY.
8	Main PCB failure	Replace the main PCB ASSY.

■ **Error code 7200**

When feeding from the MP tray, the registration rear sensor does not detect paper pass within the specified time after the registration front sensor detected paper pass.

<User Check>

- Remove the jammed paper.
- Add the paper properly using the MP tray paper guide.
- Close the front cover correctly.

Step	Cause	Remedy
1	Foreign object in the front of the machine	Remove the foreign object.
2	Registration rear actuator coming off or caught in some sections of the machine	Reattach the registration rear actuator.
3	Connection failure of the registration front/rear sensor harness	Reconnect the registration front/rear sensor harness.
4	Connection failure of the registration clutch harness	Reconnect the registration clutch harness.
5	MP feed frame attachment failure	Reattach the MP feed frame.
6	Registration rear sensor failure	Replace the registration front/rear sensor PCB ASSY.
7	Registration clutch failure	Replace the registration clutch.
8	high-voltage power supply PCB failure	Replace the high-voltage power supply PCB ASSY.
9	Damaged gears in the paper feeding system	Replace the main frame L ASSY.
10	Main PCB failure	Replace the main PCB ASSY.

■ Error code 7301

When printing from the paper tray 1, the T1 paper feed sensor does not detect paper pass within the specified time while the T1 paper empty sensor detects some paper set.

<User Check>

- Remove the jammed paper.
- Add the paper properly using the paper tray 1 paper guide.

Step	Cause	Remedy
1	Foreign object in the front of the machine	Remove the foreign object.
2	T1 paper pick up roller holder attachment failure	Reattach the T1 paper pick up roller holder.
3	T1 paper feed actuator attachment failure	Reattach the T1 paper feed actuator.
4	Connection failure of the T1 pickup clutch harness	Reattach the T1 pickup clutch harness.
5	Connection failure of the T1 paper feed sensor harness	Reconnect the T1 paper feed sensor harness.
6	Connection failure of the HVPS flat cable	Reconnect the HVPS flat cable.
7	PF kit 1 failure	Replace the PF kit 1.
8	T1 pickup clutch failure	Replace the T1 pickup clutch.
9	T1 paper feed sensor PCB failure	Replace the T1 paper feed sensor PCB ASSY.
10	T1 paper empty sensor PCB failure	Replace the T1 paper empty sensor PCB ASSY.
11	Damaged gears in the paper feeding system	Replace the main frame L ASSY.
12	High-voltage power supply PCB failure	Replace the high-voltage power supply PCB ASSY.
13	Main PCB failure	Replace the main PCB ASSY.

■ Error code 7302

When printing from the paper tray 1, the registration front sensor does not detect paper pass within the specified time after the T1 paper feed sensor detected paper pass.

<User Check>

- Remove the jammed paper.
- Add the paper properly using the paper tray 1 paper guide.

Step	Cause	Remedy
1	Foreign object in the front of the machine	Remove the foreign object.
2	Registration front actuator attachment failure	Reattach the registration front actuator.
3	Connection failure of the registration front/rear sensor harness	Reconnect the registration front/rear sensor harness.
4	Registration front/rear sensor PCB failure	Replace the registration front/rear sensor PCB ASSY.
5	high-voltage power supply PCB failure	Replace the high-voltage power supply PCB ASSY.
6	Damaged gears in the paper feeding system	Replace the main frame L ASSY.
7	Main PCB failure	Replace the main PCB ASSY.

■ **Error code 7401**

When printing from the paper tray 2, the T2(LT or TT) paper feed sensor does not detect paper pass within the specified time while the T2(LT or TT) paper empty sensor detects some paper set.

<User Check>

- Remove the jammed paper.
- Add the paper properly using the paper tray 2 paper guide.

Step	Cause	Remedy
1	Foreign object in the front of the machine	Remove the foreign object.
2	Malfunction of the LT control PCB or TT control PCB	Install the latest main firmware.
3	T2(LT or TT) paper pick up roller holder attachment failure	Reattach the T2(LT or TT) paper pick up roller holder.
4	T2(LT or TT) paper feed actuator attachment failure	Reattach the T2(LT or TT) paper feed actuator.
5	Connection failure of the T2(LT or TT) pickup clutch harness	Reconnect the T2(LT or TT) pickup clutch harness.
6	Connection failure of the T2(LT or TT) paper feed sensor harness	Reconnect the T2(LT or TT) paper feed sensor harness.
7	PF kit 2 failure	Replace the PF kit 2.
8	T2(LT or TT) pickup clutch failure	Replace the T2(LT or TT) pickup clutch.
9	T2(LT or TT) paper feed sensor PCB failure	Replace the T2(LT or TT) paper feed sensor PCB ASSY.
10	T2(LT or TT) paper empty sensor PCB failure	Replace the T2(LT or TT) paper empty sensor PCB ASSY.
11	T2LT control PCB failure	Replace the T2LT control PCB ASSY.
12	TT control PCB failure	Replace the TT control PCB ASSY.
13	TT low-voltage power supply PCB failure	Replace the TT low-voltage power supply PCB ASSY.
14	Main PCB failure	Replace the main PCB ASSY.

■ **Error code 7402**

When printing from the paper tray 2, the registration front sensor or the T2TT jam sensor does not detect paper pass within the specified time after the T2(LT or TT) paper feed sensor detected paper pass.

<User Check>

- Remove the jammed paper.
- Add the paper properly using the paper tray 2 paper guide.
- Install the latest main firmware.

Step	Cause	Remedy
1	Foreign object in the front of the machine	Remove the foreign object.
2	Registration front actuator attachment failure	Reattach the registration front actuator.
3	T2TT jam sensor attachment failure	Reattach the T2TT jam sensor.
4	Connection failure of the registration front/rear sensor harness	Reconnect the registration front/rear sensor harness.
5	Connection failure of the T2TT jam sensor harness	Reconnect the T2TT jam sensor harness.
6	Connection failure of the TT control PCB harness	Reconnect the TT control PCB harness.
7	Connection failure of the T2LT control PCB harness	Reconnect the T2LT control PCB harness.
8	Connection failure of the T2LT release clutch harness	Reconnect the T2LT release clutch harness.
9	T2LT release clutch failure	Replace the T2LT release clutch.
10	Registration front/rear sensor PCB failure	Replace the registration front/rear sensor PCB ASSY.
11	T2TT jam sensor PCB failure	Replace the T2TT jam sensor PCB ASSY.
12	TT control PCB failure	Replace the TT control PCB ASSY.
13	T2LT control PCB failure	Replace the T2LT control PCB ASSY.
14	high-voltage power supply PCB failure	Replace the high-voltage power supply PCB ASSY.
15	Damaged gears in the paper feeding system	Replace the main frame L ASSY.
16	Damaged gears in the LT paper feeding system	Replace the LT.
17	Damaged gears in the TT paper feeding system	Replace the TT.
18	Main PCB failure	Replace the main PCB ASSY.

■ **Error code 7501**

When printing from the paper tray 3, the T3(LT or TT) paper feed sensor does not detect paper pass within the specified time while the T3(LT or TT) paper empty sensor detects some paper set.

<User Check>

- Remove the jammed paper.
- Add the paper properly using the paper tray 3 paper guide.

Step	Cause	Remedy
1	Foreign object in the front of the machine	Remove the foreign object.
2	Malfunction of the LT control PCB or TT control PCB	Install the latest main firmware.
3	T3(LT or TT) paper pick up roller holder attachment failure	Reattach the T3(LT or TT) paper pick up roller holder.
4	T3(LT or TT) paper feed actuator attachment failure	Reattach the T3(LT or TT) paper feed actuator.
5	Connection failure of the T3(LT or TT) pickup clutch harness	Reconnect the T3(LT or TT) pickup clutch harness.
6	Connection failure of the T3(LT or TT) paper feed sensor harness	Reconnect the T3(LT or TT) paper feed sensor harness.
7	PF kit 3 failure	Replace the PF kit 3.
8	T3(LT or TT) pickup clutch failure	Replace the T3(LT or TT) pickup clutch.
9	T3(LT or TT) paper feed sensor PCB failure	Replace the T3(LT or TT) paper feed sensor PCB ASSY.
10	T3(LT or TT) paper empty sensor PCB failure	Replace the T3(LT or TT) paper empty sensor PCB ASSY.
11	T3LT control PCB failure	Replace the T3LT control PCB ASSY.
12	TT control PCB failure	Replace the TT control PCB ASSY.
13	TT low-voltage power supply PCB failure	Replace the TT low-voltage power supply PCB ASSY.
14	Main PCB failure	Replace the main PCB ASSY.

■ **Error code 7502**

When printing from the paper tray 3, the registration front sensor or the T2/T3TT jam sensor does not detect paper pass within the specified time after the T3(LT or TT) paper feed sensor detected paper pass.

<User Check>

- Remove the jammed paper.
- Add the paper properly using the paper tray 3 paper guide.
- Install the latest main firmware.

Step	Cause	Remedy
1	Foreign object in the front of the machine	Remove the foreign object.
2	Registration front actuator attachment failure	Reattach the registration front actuator.
3	T2/T3TT jam sensor attachment failure	Reattach the T2/T3TT jam sensor.
4	Connection failure of the registration front/rear sensor harness	Reconnect the registration front/rear sensor harness.
5	Connection failure of the T2/T3TT jam sensor harness	Reconnect the T2/T3TT jam sensor harness.
6	Connection failure of the TT control PCB harness	Reconnect the TT control PCB harness.
7	Connection failure of the T2/T3LT control PCB harness	Reconnect the T2/T3LT control PCB harness.
8	Connection failure of the T2/T3LT release clutch harness	Reconnect the T2/T3LT release clutch harness.
9	Connection failure of the T3TT release clutch harness	Reconnect the T3TT release clutch harness.
10	T2/T3LT release clutch failure	Replace the T2/T3LT release clutch.
11	T3TT release clutch failure	Replace the T3TT release clutch.
12	Registration front/rear sensor PCB failure	Replace the registration front/rear sensor PCB ASSY.
13	T2/T3TT jam sensor PCB failure	Replace the T2/T3TT jam sensor PCB ASSY.
14	TT control PCB failure	Replace the TT control PCB ASSY.
15	T2/T3LT control PCB failure	Replace the T2/T3LT control PCB ASSY.
16	high-voltage power supply PCB failure	Replace the high-voltage power supply PCB ASSY.
17	Damaged gears in the paper feeding system	Replace the main frame L ASSY.
18	Damaged gears in an LT paper feeding system	Replace the LT.
19	Damaged gears in the TT paper feeding system	Replace the TT.
20	Main PCB failure	Replace the main PCB ASSY.

■ Error code 7601

When printing from the paper tray 4, the T4(LT or TT) paper feed sensor does not detect paper pass within the specified time while the T4(LT or TT) paper empty sensor detects some paper set.

<User Check>

- Remove the jammed paper.
- Add the paper properly using the paper tray 4 paper guide.

Step	Cause	Remedy
1	Foreign object in the front of the machine	Remove the foreign object.
2	Malfunction of the LT control PCB or TT control PCB	Install the latest main firmware.
3	T4(LT or TT) paper pick up roller holder attachment failure	Reattach the T4(LT or TT) paper pick up roller holder.
4	T4(LT or TT) paper feed actuator attachment failure	Reattach the T4(LT or TT) paper feed actuator.
5	Connection failure of the T4(LT or TT) pickup clutch harness	Reconnect the T4(LT or TT) pickup clutch harness.
6	Connection failure of the T4(LT or TT) paper feed sensor harness	Reconnect the T4(LT or TT) paper feed sensor harness.
7	PF kit 4 failure	Replace the PF kit 4.
8	T4(LT or TT) pickup clutch failure	Replace the T4(LT or TT) pickup clutch.
9	T4(LT or TT) paper feed sensor PCB failure	Replace the T4(LT or TT) paper feed sensor PCB ASSY.
10	T4(LT or TT) paper empty sensor PCB failure	Replace the T4(LT or TT) paper empty sensor PCB ASSY.
11	T4LT control PCB failure	Replace the T4LT control PCB ASSY.
12	TT control PCB failure	Replace the TT control PCB ASSY.
13	TT low-voltage power supply PCB failure	Replace the TT low-voltage power supply PCB ASSY.
14	Main PCB failure	Replace the main PCB ASSY.

■ Error code 7602

When printing from the paper tray 4, the registration front sensor or the T2/T3/T4TT jam sensor does not detect paper pass within the specified time after the T4(LT or TT) paper feed sensor detected paper pass.

<User Check>

- Remove the jammed paper.
- Add the paper properly using the paper tray 4 paper guide.
- Install the latest main firmware.

Step	Cause	Remedy
1	Foreign object in the front of the machine	Remove the foreign object.
2	Registration front actuator attachment failure	Reattach the registration front actuator.
3	T2/T3/T4TT jam sensor attachment failure	Reattach the T2/T3/T4TT jam sensor.
4	Connection failure of the registration front/rear sensor harness	Reconnect the registration front/rear sensor harness.
5	Connection failure of the T2/T3/T4TT jam sensor harness	Reconnect the T2/T3/T4TT jam sensor harness.
6	Connection failure of the TT control PCB harness	Reconnect the TT control PCB harness.
7	Connection failure of the T2/T3/T4LT control PCB harness	Reconnect the T2/T3/T4LT control PCB harness.
8	Connection failure of the T2/T3/T4LT release clutch harness	Reconnect the T2/T3/T4LT release clutch harness.
9	Connection failure of the T3/T4TT release clutch harness	Reconnect the T3/T4TT release clutch harness.
10	T2/T3/T4LT release clutch failure	Replace the T2/T3/T4LT release clutch.
11	T3/T4TT release clutch failure	Replace the T3/T4TT release clutch.
12	Registration front/rear sensor PCB failure	Replace the registration front/rear sensor PCB.
13	T2/T3/T4TT jam sensor PCB failure	Replace the T2/T3/T4TT jam sensor PCB ASSY.
14	TT control PCB failure	Replace the TT control PCB ASSY.
15	T2/T3/T4LT control PCB failure	Replace the T2/T3/T4LT control PCB ASSY.
16	high-voltage power supply PCB failure	Replace the high-voltage power supply PCB ASSY.
17	Damaged gears in the paper feeding system	Replace the main frame L ASSY.
18	Damaged gears in an LT paper feeding system	Replace the LT.
19	Damaged gears in the TT paper feeding system	Replace the TT.
20	Main PCB failure	Replace the main PCB ASSY.

■ **Error code 7701**

When printing from the paper tray 5, the T5TT paper feed sensor does not detect paper pass within the specified time while the T5TT paper empty sensor detects some paper set.

<User Check>

- Remove the jammed paper.
- Add the paper properly using the paper tray 5 paper guide.

Step	Cause	Remedy
1	Foreign object in the front of the machine	Remove the foreign object.
2	Malfunction of the TT control PCB	Connect the TT and install the latest main firmware.
3	T5TT paper pick up roller holder attachment failure	Reattach the T5TT paper pick up roller holder.
4	T5TT paper feed actuator attachment failure	Reattach the T5TT paper feed actuator.
5	Connection failure of the T5TT pickup clutch harness	Reconnect the T5TT pickup clutch harness.
6	Connection failure of the T5TT paper feed sensor harness	Reconnect the T5TT paper feed sensor harness.
7	PF kit 5 failure	Replace the PF kit 5.
8	T5TT pickup clutch failure	Replace the T5TT pickup clutch.
9	T5TT paper feed sensor PCB failure	Replace the T5TT paper feed sensor PCB ASSY.
10	T5TT paper empty sensor PCB failure	Replace the T5TT paper empty sensor PCB ASSY.
11	TT control PCB failure	Replace the TT control PCB ASSY.
12	TT low-voltage power supply PCB failure	Replace the TT low-voltage power supply PCB ASSY.
13	Main PCB failure	Replace the main PCB ASSY.

■ Error code 7702

When printing from the paper tray 5, the registration front sensor or the T2/T3/T4/T5TT jam sensor does not detect paper pass within the specified time after the T5TT paper feed sensor detected paper pass.

<User Check>

- Remove the jammed paper.
- Add the paper properly using the paper tray 5 paper guide.
- Install the latest main firmware.

Step	Cause	Remedy
1	Foreign object in the front of the machine	Remove the foreign object.
2	Registration front actuator attachment failure	Reattach the registration front actuator.
3	T2/T3/T4/T5TT jam sensor attachment failure	Reattach the T2/T3/T4/T5TT jam sensor.
4	Connection failure of the registration front/rear sensor harness	Reconnect the registration front/rear sensor harness.
5	Connection failure of the T2/T3/T4/T5TT jam sensor harness	Reconnect the T2/T3/T4/T5TT jam sensor harness.
6	Connection failure of the TT control PCB harness	Reconnect the TT control PCB harness.
7	Connection failure of the T3/T4/T5TT release clutch harness	Reconnect the T3/T4/T5TT release clutch harness.
8	T3/T4/T5TT release clutch failure	Replace the T3/T4/T5TT release clutch.
9	Registration front/rear sensor PCB failure	Replace the registration front/rear sensor PCB ASSY.
10	T2/T3/T4/T5TT jam sensor PCB failure	Replace the T2/T3/T4/T5TT jam sensor PCB ASSY.
11	TT control PCB failure	Replace the TT control PCB ASSY.
12	high-voltage power supply PCB failure	Replace the high-voltage power supply PCB ASSY.
13	Damaged gears in the TT paper feeding system	Replace the TT.
14	Main PCB failure	Replace the main PCB ASSY.

■ **Error code 7800**

The registration front sensor does not detect paper pass within the specified time after the first side was printed in duplex printing mode.

<User Check>

- Remove the jammed paper.
- Close the back cover correctly.
- Attach the duplex tray correctly.

Step	Cause	Remedy
1	Foreign object in the rear of the machine or duplex tray	Remove the foreign object.
2	Connection failure of the eject motor harness	Reconnect the eject motor harness.
3	Duplex tray failure	Replace the duplex tray.
4	Eject motor failure	Replace the eject motor.
5	Damaged gears in the paper feeding system	Replace the main frame L ASSY.
6	Paper eject roller failure	Replace the paper eject roller.
7	Main PCB failure	Replace the main PCB ASSY.

■ Error code 8501

When printing from paper tray 1 to 5, the T1 paper feed sensor detected open paper tray 1 (before registering printing data to engine).

Error code 8502

When printing from paper tray 2 to 5, the T2(LT or TT) paper feed sensor detected open paper tray 2 (before registering printing data to engine).

Error code 8503

When printing from paper tray 3 to 5, the T3(LT or TT) paper feed sensor detected open paper tray 3 (before registering printing data to engine).

Error code 8504

When printing from paper tray 4 to 5, the T4(LT or TT) paper feed sensor detected open paper tray 4 (before registering printing data to engine).

<User Check>

- Close the appropriate paper tray correctly.

Step	Cause	Remedy
1	Malfunction of an LT control PCB or TT control PCB	Install the latest main firmware.
2	An LT/TT paper feed actuator coming off or caught in some sections of the machine	Reattach the appropriate LT/TT paper feed actuator.
3	An LT/TT paper feed sensor failure	Replace the appropriate LT/TT paper feed sensor PCB ASSY.
4	High-voltage power supply PCB failure	Replace the high-voltage power supply PCB ASSY.
5	An LT control PCB failure	Replace the appropriate LT control PCB ASSY.
6	TT relay PCB failure	Replace a TT relay PCB ASSY.
7	TT control PCB failure	Replace the TT control PCB ASSY.
8	Main PCB failure	Replace the main PCB ASSY.

■ **Error code 8505**

When printing from paper tray 1 to 5, the T1 paper feed sensor detected open paper tray 1 (after registering printing data to engine).

Error code 8506

When printing from paper tray 2 to 5, the T2(LT or TT) paper feed sensor detected open paper tray 2 (after registering printing data to engine).

Error code 8507

When printing from paper tray 3 to 5, the T3(LT or TT) paper feed sensor detected open paper tray 3 (after registering printing data to engine).

Error code 8508

When printing from paper tray 4 to 5, the T4(LT or TT) paper feed sensor detected open paper tray 4 (after registering printing data to engine).

<User Check>

- Close the appropriate paper tray correctly.

Step	Cause	Remedy
1	Malfunction of an LT control PCB or TT control PCB	Install the latest main firmware.
2	An LT/TT paper feed sensor failure	Replace the appropriate LT/TT paper feed sensor PCB ASSY.
3	An LT control PCB failure	Replace the appropriate LT control PCB ASSY.
4	TT relay PCB failure	Replace a TT relay PCB ASSY.
5	TT control PCB failure	Replace the TT control PCB ASSY.
6	Main PCB failure	Replace the main PCB ASSY.

■ **Error code 8702**

Machine stack sensor detected the ejected paper full state at the start of printing.

<User Check>

- Remove the paper from the machine output tray.

Step	Cause	Remedy
1	Machine stack actuator coming off or caught in some sections of the machine	Reattach the machine stack actuator.
2	Machine stack sensor failure	Replace the machine stack sensor.
3	Main PCB failure	Replace the main PCB ASSY.

■ **Error code 8903**

The back cover/duplex tray sensor detected that the cover was open when duplex printing is started. (Before registering printing data to engine)

■ **Error code 8904**

The back cover/duplex tray sensor detected that the cover was open during duplex printing. (After registering printing data to engine)

<User Check>

- Close the back cover correctly.
- Attach the duplex tray correctly.

Step	Cause	Remedy
1	Back cover/duplex tray sensor attachment failure	Reattach the back cover/duplex tray sensor.
2	Connection failure of the back cover/duplex tray sensor harness	Reconnect the back cover/duplex tray sensor harness.
3	Damaged back cover	Replace the back cover.
4	Damaged duplex tray	Replace the duplex tray.
5	Main PCB failure	Replace the main PCB ASSY.

■ **Error code 8A01**

The registration rear sensor detected that the paper fed was smaller or larger than the specified size in duplex printing mode.

<User Check>

- Use specified paper.

Step	Cause	Remedy
1	Registration rear actuator caught in some sections of the machine	Reattach the registration rear actuator.
2	Registration rear sensor failure	Replace the registration front/rear sensor PCB ASSY.
3	high-voltage power supply PCB failure	Replace the high-voltage power supply PCB ASSY.
4	Main PCB failure	Replace the main PCB ASSY.

■ **Error code 8B01**

Detected that the TT was not turned ON.

<User Check>

- Turn ON the TT.
- Reconnect the AC cord of the TT.

Step	Cause	Remedy
1	Malfunction of the TT control PCB	Install the latest main firmware.
2	Connection failure of the TT low-voltage power supply PCB harness	Reconnect the TT low-voltage power supply PCB harness.
3	TT AC cord breakage	Replace the AC cord.
4	TT low-voltage power supply PCB failure	Replace the TT low-voltage power supply PCB ASSY.
5	TT control PCB failure	Replace the TT control PCB ASSY.
6	Main PCB failure	Replace the main PCB ASSY.

■ **Error code 8E02**

Detected that the size of the paper set to paper tray was over 10 mm shorter than letter size when receiving fax or printing a list/report.

<User Check>

- Set A4 or Letter-size paper.

Step	Cause	Remedy
1	Registration rear actuator caught in some sections of the machine	Reattach the registration rear actuator.
2	Registration rear sensor failure	Replace the registration front/rear sensor PCB ASSY.
3	Main PCB failure	Replace the main PCB ASSY.

■ **Error code 9001**

When printing from the MP tray, the size of paper set in the MP tray does not match the size specified by the driver.

Error code 9002

When printing from the paper tray 1, the size of paper set in the paper tray 1 does not match the size specified by the driver.

Error code 9003

When printing from the paper tray 2, the size of paper set in the paper tray 2 does not match the size specified by the driver.

Error code 9004

When printing from the paper tray 3, the size of paper set in the paper tray 3 does not match the size specified by the driver.

Error code 9005

When printing from the paper tray 4, the size of paper set in the paper tray 4 does not match the size specified by the driver.

Error code 9006

When printing from the paper tray 5, the size of paper set in the paper tray 5 does not match the size specified by the driver.

<User Check>

- Change the driver setting to be matched with the size of the paper set in the paper tray.

Step	Cause	Remedy
1	Registration rear actuator caught in some sections of the machine	Reattach the registration rear actuator.
2	Registration rear sensor failure	Replace the registration front/rear sensor PCB ASSY.
3	Main PCB failure	Replace the main PCB ASSY.

■ **Error code 9201**

When printing from the MP tray, paper type setting in the machine does not match the setting in the driver.

Error code 9202

When printing from the paper tray 1, paper type setting in the machine does not match the setting in the driver.

Error code 9203

When printing from the paper tray 2, paper type setting in the machine does not match the setting in the driver.

Error code 9204

When printing from the paper tray 3, paper type setting in the machine does not match the setting in the driver.

Error code 9205

When printing from the paper tray 4, paper type setting in the machine does not match the setting in the driver.

Error code 9206

When printing from the paper tray 5, paper type setting in the machine does not match the setting in the driver.

<User Check>

- Use the same paper type setting for the machine and driver.

Step	Cause	Remedy
1	Malfunction of the main PCB	Install the latest main firmware.
2	Main PCB failure	Replace the main PCB ASSY.

■ **Error code 9301**

When printing from the MP tray, the MP paper empty sensor detected that there was no paper set in the MP tray.

Error code 9302

When printing from paper tray 1, the T1 paper empty sensor or the T1 paper feed sensor detected that there was no paper set in paper tray 1.

Error code 9303

When printing from paper tray 2, the T2(LT or TT) paper empty sensor detected that there was no paper set in paper tray 2.

Error code 9304

When printing from paper tray 3, the T3(LT or TT) paper empty sensor detected that there was no paper set in paper tray 3.

Error code 9305

When printing from paper tray 4, the T4(LT or TT) paper empty sensor detected that there was no paper set in paper tray 4.

Error code 9306

When printing from paper tray 5, the T5TT paper empty sensor detected that there was no paper set in paper tray 5.

<User Check>

- Set paper in the appropriate paper tray.

Step	Cause	Remedy
1	Malfunction of an LT control PCB or TT control PCB	Install the latest main firmware.
2	Connection failure of a LT/TT paper empty sensor harness	Reconnect the appropriate LT/TT paper empty sensor harness.
3	An LT/TT paper empty actuator caught in some sections of the machine	Reattach the appropriate LT/TT paper empty actuator.
4	An LT/TT paper empty sensor PCB failure	Replace the appropriate LT/TT paper empty sensor PCB ASSY.
5	High-voltage power supply PCB failure	Replace the high-voltage power supply PCB ASSY.
6	An LT control PCB failure	Replace the appropriate LT control PCB ASSY.
7	TT relay PCB failure	Replace a TT relay PCB ASSY.
8	TT control PCB failure	Replace the TT control PCB ASSY.
9	Main PCB failure	Replace the main PCB ASSY.

■ **Error code 9309**

Detected that there was no paper set in all trays when TrayAuto was selected for printing.

<User Check>

- Set paper in the paper tray.

Step	Cause	Remedy
1	Malfunction of an LT control PCB or TT control PCB	Install the latest main firmware.
2	Connection failure of an LT/TT paper empty sensor harness	Reconnect the appropriate LT/TT paper empty sensor harness.
3	Connection failure of the T1 paper feed sensor harness	Reconnect the T1 paper feed sensor harness. (Models with 250-sheet only)
4	An LT/TT paper empty actuator caught in some sections of the machine	Reattach the appropriate LT/TT paper empty actuator.
5	T1 paper feed actuator caught in some sections of the machine	Reattach the T1 paper feed actuator. (Models with 250-sheet only)
6	Abrasion of a PF kit	Replace the appropriate PF kit.
7	An LT/TT paper empty sensor PCB failure	Replace the appropriate LT/TT paper empty sensor PCB ASSY.
8	T1 paper feed sensor PCB failure	Replace the T1 paper feed sensor PCB ASSY. (Models with 250-sheet only)
9	T1, T2, or T3(LT or TT) pickup clutch failure	Replace the T1, T2, or T3(LT or TT) pickup clutch.
10	Paper feed motor failure	Replace the paper feed motor. (Models with 250-sheet only)
11	High-voltage power supply PCB failure	Replace the high-voltage power supply PCB ASSY.
12	An LT control PCB failure	Replace the appropriate LT control PCB ASSY.
13	TT relay PCB failure	Replace a TT relay PCB ASSY.
14	TT control PCB failure	Replace the TT control PCB ASSY.
15	Damaged gears in the paper feeding system	Replace the main frame L ASSY. (Models with 250-sheet only)
16	Main PCB failure	Replace the main PCB ASSY.

■ Error code 930A

Paper ran out during Fax / List continuous printing.

<User Check>

- Set paper in the appropriate paper tray.
- Install the latest main firmware.

Step	Cause	Remedy
1	A paper empty actuator caught in some sections of the machine ^{*1}	Reattach the appropriate paper empty actuator. ^{*1}
2	A paper feed actuator caught in some sections of the machine ^{*2}	Reattach the appropriate paper feed actuator. ^{*2}
3	Connection failure of a paper feed sensor harness ^{*2}	Reconnect the appropriate paper feed sensor harness. ^{*2}
4	Connection failure of the HVPS flat cable ^{*2}	Reconnect the HVPS flat cable. ^{*2}
5	Connection failure of the LT control PCB harness ^{*2}	Reconnect the LT control PCB harness. ^{*2}
6	A paper empty sensor PCB failure ^{*1}	Replace the appropriate paper empty sensor PCB ASSY. ^{*1}
7	A paper feed sensor PCB failure ^{*2}	Replace the appropriate paper feed sensor PCB ASSY. ^{*2}
8	LT control PCB failure	Replace the LT control PCB.
9	High-voltage power supply PCB failure ^{*2}	Replace the high-voltage power supply PCB. ^{*2}
10	A TT relay PCB failure ^{*1}	Replace the TT relay PCB. ^{*1}
11	TT control PCB failure ^{*1}	Replace the TT control PCB. ^{*1}
12	Low-voltage power supply PCB failure ^{*2}	Replace the Low-voltage power supply PCB ASSY. ^{*2}
13	Main PCB failure	Replace the main PCB ASSY.

Note:

Only for when each tray above is set for A4 / Letter / Legal / Folio.

^{*1} Models with 520-sheet only

^{*2} Models with 250-sheet only

■ Error code 9400

Firmware version of the main PCB is older than that of the TT and LT.

<User Check>

- Install the latest main firmware.

Step	Cause	Remedy
1	Main firmware version and firmware version of the TT and LT do not match	Install the latest main firmware.

■ **Error code 9701**

A tray set to duplex printing-incompatible size was specified in duplex printing.

Error code 9702

When printing from paper tray 1, a paper size not supported for paper tray 1 was specified from the driver.

Error code 9703

When printing from paper tray 2, a paper size not supported for paper tray 2 was specified from the driver.

Error code 9704

When printing from paper tray 3, a paper size not supported for paper tray 3 was specified from the driver.

Error code 9705

When printing from paper tray 4, a paper size not supported for paper tray 4 was specified from the driver.

Error code 9706

When printing from paper tray 5, a paper size not supported for paper tray 5 was specified from the driver.

<User Check>

- Select the specified paper size in the driver and set paper with the same size to the specified paper tray.

Step	Cause	Remedy
1	Main PCB failure	Replace the main PCB ASSY.

■ **Error code 9B03**

Only T2 tray is set for A4 / Letter / Legal / Folio but T2 is set as "Skip Tray".

Error code 9B04

Only T3 tray is set for A4 / Letter / Legal / Folio but T3 is set as "Skip Tray".

Error code 9B05

Only T4 tray is set for A4 / Letter / Legal / Folio but T4 is set as "Skip Tray".

Error code 9B06

Only T5 tray is set for A4 / Letter / Legal / Folio but T5 is set as "Skip Tray".

<User Check>

- Check the paper or Skip Tray setting.

Step	Cause	Remedy
1	Main PCB failure	Replace the main PCB ASSY.

■ **Error code A000**

Image processing was not completed correctly because the number of pixels required for image processing is insufficient in the scanned second side data.

Step	Cause	Remedy
1	Incorrect correction data for second side CIS unit	Execute "Set CIS scan area (function code: 55)".
2	Second side CIS unit failure	Replace the second side CIS unit.
3	Main PCB failure	Replace the main PCB ASSY.

■ **Error code A200**

The document scanning position sensor detected that the document length was 90 cm or more during the one-side scanning.

<User Check>

- Set the specified size paper.
- Remove the jammed document.

Step	Cause	Remedy
1	Document scanning position actuator caught in some sections of the machine	Reattach the document scanning position actuator.
2	Document scanning position sensor failure	Replace the ADF unit.
3	Main PCB failure	Replace the main PCB ASSY.

■ **Error code A300**

The document scanning position sensor has not detected the document passing even after the document has been fed for the specified time.

<User Check>

- Set A4 or Letter size paper.
- Remove the jammed document.

Step	Cause	Remedy
1	Document scanning position actuator caught in some sections of the machine	Reattach the document scanning position actuator.
2	Connection failure of the document scanning position sensor harness	Reconnect the document scanning position sensor harness.
3	Document scanning position sensor failure	Replace the ADF unit.
4	Main PCB failure	Replace the main PCB ASSY.

■ **Error code A400**

The ADF cover sensor detected that the ADF cover was open.

<User Check>

- Close the ADF cover correctly.

Step	Cause	Remedy
1	A part to push the ADF cover sensor in the ADF cover is broken.	Replace the ADF cover ASSY.
2	ADF cover sensor failure	Replace the ADF unit.
3	Main PCB failure	Replace the main PCB ASSY.

■ **Error code A500**

When scanning the fax, white or black correction data for the first side CIS unit was not within the correct range (first time).

Error code A600

When scanning the fax, white or black correction data for the first side CIS unit was not within the correct range (second time).

Step	Cause	Remedy
1	Incorrect correction data for first side CIS unit	Execute "Acquire white level data (function code: 55)".
2	Dirt on the white tape on the second side document hold	Clean the white tape on the second side document hold.
3	First side CIS unit failure	Replace the first side CIS unit.
4	White tape failure	Replace the document scanner unit.
5	Main PCB failure	Replace the main PCB ASSY.

■ **Error code A700**

Color parameter in the ROM does not match the first side or second side CIS.

■ **Error code A900**

A scanning error occurred while processing the scanned image.

Step	Cause	Remedy
1	Incorrect correction data for first side or second side CIS unit	Execute "Acquire white level data (function code: 55)".
2	Damaged first side CIS flat cable	Replace the first side CIS flat cable.
3	Damaged second side CIS flat cable	Replace the second side CIS flat cable.
4	First side CIS unit failure	Replace the first side CIS unit.
5	Second side CIS unit failure	Replace the second side CIS unit.
6	Main PCB failure	Replace the main PCB ASSY.

■ **Error code AC00**

When scanning the fax, white or black correction data for the second side CIS was not within the correct range (first time).

Step	Cause	Remedy
1	Incorrect correction data for second side CIS unit	Execute "Acquire white level data (function code: 55)".
2	Dirt on the white tape on the second side document hold	Clean the white tape on the second side document hold.
3	Second side CIS unit failure	Replace the second side CIS unit.
4	Main PCB failure	Replace the main PCB ASSY.

■ **Error code AD00**

Image processing cannot be completed correctly because the number of pixels required for image processing is insufficient in the scanned first side data.

Step	Cause	Remedy
1	Incorrect correction data for first side CIS unit	Execute "Acquire white level data (function code: 55)".
2	First side CIS unit failure	Replace the first side CIS unit.
3	White tape failure	Replace the document scanner unit.
4	Main PCB failure	Replace the main PCB ASSY.

■ **Error code AE00**

Unit home position could not be detected after the power switch was turned ON.

Step	Cause	Remedy
1	Incorrect correction data for first side CIS unit	Execute "Acquire white level data (function code: 55)".
2	First side CIS unit drive belt coming off	Reattach the first side CIS unit drive belt.
3	First side CIS unit failure	Replace the first side CIS unit.
4	FB motor failure	Replace the document scanner unit.
5	Main PCB failure	Replace the main PCB ASSY.

■ **Error code AF00**

Home position is still being detected even after the first side CIS unit was moved.

Step	Cause	Remedy
1	Dust on the CIS guide shaft	Remove the dust on the CIS guide shaft.
2	CIS drive belt coming off	Reattach the CIS drive belt.
3	CIS carriage coming off	Reattach the CIS carriage.
4	Connection failure of the FB motor harness	Reconnect the FB motor harness.
5	First side CIS unit failure	Replace the first side CIS unit.
6	FB motor failure	Replace the document scanner unit.
7	Main PCB failure	Replace the main PCB ASSY.

■ **Error code B000**

Detected that the first side CIS flat cable or second side CIS flat cable was not inserted correctly when function code 55 was executed.

Step	Cause	Remedy
1	Connection failure of the first side CIS flat cable	Reconnect the first side CIS flat cable.
2	Connection failure of the second side CIS flat cable	Reconnect the second side CIS flat cable.
3	First side CIS unit failure	Replace the first side CIS unit.
4	Second side CIS unit failure	Replace the second side CIS unit.
5	Main PCB failure	Replace the main PCB ASSY.

■ **Error code BB00**

A white level not within the standard was scanned when function code 55 was executed.

Step	Cause	Remedy
1	Dirt on the second side document hold	Clean the second side document hold.
2	Dirt on the white tape	Clean the white tape.
3	First side CIS unit failure	Replace the first side CIS unit.
4	Second side CIS unit failure	Replace the second side CIS unit.
5	Second side document hold failure	Replace the ADF unit.
6	White tape failure	Replace the document scanner unit.
7	Main PCB failure	Replace the main PCB ASSY.

■ **Error code BC00**

When scanning the fax, white or black correction data for the second side CIS was not within the correct range (second time).

Step	Cause	Remedy
1	Incorrect correction data for second side CIS unit	Execute "Acquire white level data (function code: 55)".
2	Dirt on the white tape on the second side document hold	Clean the white tape on the second side document hold.
3	Second side CIS unit failure	Replace the second side CIS unit.
4	Main PCB failure	Replace the main PCB ASSY.

■ **Error code BD00**

A black level not within the standard was scanned when function code 55 was executed.

Step	Cause	Remedy
1	Dirt on the second side document hold	Clean the second side document hold.
2	Dirt on the white tape	Clean the white tape.
3	First side CIS unit failure	Replace the first side CIS unit.
4	Second side CIS unit failure	Replace the second side CIS unit.
5	Second side document hold failure	Replace the ADF unit.
6	White tape failure	Replace the document scanner unit.
7	Main PCB failure	Replace the main PCB ASSY.

■ **Error code BF00**

The document scanning position sensor detected that the document length was 400 mm or longer and could not be fed to ADF (double-side restoration).

<User Check>

- Set the specified size paper.

Step	Cause	Remedy
1	Document scanning position actuator caught in some sections of the machine	Reattach the document scanning position actuator.
2	Document scanning position sensor failure	Replace the ADF unit.
3	Main PCB failure	Replace the main PCB ASSY.

■ **Error code C001**

Access request to the server timed out because the server address was wrong, network was not connected, or server was not working.

Error code C002

User authentication error due to wrong user name, wrong password, or date and time was not synchronized between the machine and server.

Error code C003

Cannot access to the file because the directory name is wrong, writing into directory is not permitted, or writing into file is locked or not permitted.

Error code C004

Cannot acquire current time which is required for user authentication because the time has not been acquired.

<User Check>

- Refer to the online User's Guide to set the network again.
- Check the LAN cable routing.
- Check the wireless LAN settings.

Step	Cause	Remedy
1	Connection failure of the wireless LAN PCB connector	Reconnect the wireless LAN PCB connector.
2	Wireless LAN PCB failure	Replace the wireless LAN PCB ASSY.
3	Main PCB failure	Replace the main PCB ASSY.

■ **Error code C100**

Failed to save data to a USB flash memory.

<User Check>

- Change the USB flash memory.
- Check if there is sufficient memory in the USB flash memory.

Step	Cause	Remedy
1	Main PCB failure	Replace the main PCB ASSY.

■ **Error code C700**

There is insufficient memory to expand PC print data.

<User Check>

- Print the print data stored in the memory.
- Divide the print data and print them separately.

Step	Cause	Remedy
1	Main PCB failure	Replace the main PCB ASSY.

■ **Error code C800**

The memory size allotted for Secure Print was exceeded when saving Secure Print data.

<User Check>

- Print the print data stored in the memory.
- Divide the print data and print them separately.

Step	Cause	Remedy
1	Main PCB failure	Replace the main PCB ASSY.

■ **Error code D100**

An error occurred while initializing the modem.

Step	Cause	Remedy
1	Connection failure of the modem flat cable	Reconnect the modem flat cable.
2	Modem PCB failure	Replace the modem PCB ASSY.
3	Main PCB failure	Replace the main PCB ASSY.

■ **Error code D200**

Detected that the modem PCB is not connected.

Step	Cause	Remedy
1	Modem PCB failure	Replace the modem PCB ASSY.
2	Main PCB failure	Replace the main PCB ASSY.

■ **Error code D800**

An error occurred while initializing the touch panel.

Step	Cause	Remedy
1	Panel firmware version and main firmware version do not match	Install the latest main firmware.
2	Connection failure of the panel flat cable	Reconnect the panel flat cable.
3	LCD relay PCB failure	Replace the LCD panel ASSY.
4	Main PCB failure	Replace the main PCB ASSY.

■ **Error code E000**

An error occurred in the ROM check sum.

Error code E100

Program error

Step	Cause	Remedy
1	Malfunction of the main firmware	Install the latest main firmware.
2	Main PCB failure	Replace the main PCB ASSY.

■ **Error code E500**

An error occurred during access to the DRAM in the main PCB ASSY.

Error code E600

Write error in the EEPROM of the main PCB ASSY

Error code E701

System error in the flash ROM

Error code E702

Read error in the flash ROM

Step	Cause	Remedy
1	Malfunction of the main firmware	Install the latest main firmware.
2	Main PCB failure	Replace the main PCB ASSY.

■ **Error code E900**

An error occurred while initializing the NFC.

Step	Cause	Remedy
1	Connection failure of the panel flat cable	Reconnect the panel flat cable.
2	Connection failure of the NFC flat cable	Reconnect the NFC flat cable.
3	Panel PCB failure	Replace the panel PCB ASSY.
4	NFC PCB failure	Replace the NFC PCB ASSY.
5	Main PCB failure	Replace the main PCB ASSY.

■ **Error code EC00**

A USB device not within the specification is connected to the USB terminal, resulting in over current.

<User Check>

- Disconnect the USB device from the USB flash memory port and turn the machine OFF. Turn the machine ON again after a while.
- Replace the USB device with a different one.

Step	Cause	Remedy
1	USB host PCB failure	Replace the USB host PCB ASSY.
2	Main PCB failure	Replace the main PCB ASSY.

■ **Error code ED00**

Failed to authenticate the firmware for the self test.

Error code EE00

Failed to authenticate the NVRAM for the self test.

<User Check>

- Turn the power switch OFF and then ON again.

Step	Cause	Remedy
1	Main PCB failure	Replace the main PCB ASSY.

■ **Error code F900**

The spec code was not entered correctly.

Step	Cause	Remedy
1	The power was turned OFF while function code 74 was running.	Reenter the spec code.
2	Main PCB failure	Replace the main PCB ASSY.

4.2 Troubleshooting for Paper Feeding Problems

End users can solve problems related to paper feeding as long as they follow the User Check items. If the problem still cannot be solved, implement each procedure according to the step numbers in the tables below.

4.2.1 No paper is fed from machine paper tray

<User Check>

- Check that the paper is set in the paper tray correctly.
- Check that there is not too much paper set in the paper tray.
- Flip over the paper in the paper tray or rotate the paper 180°.
- Check that the thickness of the paper is 60 to 120 g/m² (paper tray 1).
- Check that the MP tray, LT or TT is not set as the paper tray.
- Flip through the paper and reset it in the paper tray.
- Clean the paper pick up roller.
- Install the latest main firmware.

Step	Cause	Remedy
1	Dirt on the paper dust cleaning roller of the paper tray	Refer to the figure below to clean the paper dust cleaning roller.
2	Attachment failure of the T1 roller holder ASSY	Reattach the T1 roller holder ASSY correctly.
3	Connection failure of the paper feed motor harness	Reconnect the paper feed motor harness.
4	Connection failure of the T1 paper feed sensor harness	Reconnect the T1 paper feed sensor harness.
5	Connection failure of the HVPS flat cable	Reconnect the HVPS flat cable.
6	Connection failure of the T1 pickup clutch harness	Reconnect the T1 pickup clutch harness.
7	T1 paper empty actuator coming off	Reattach the T1 paper empty actuator.
8	Abrasion of the paper pick up roller	Replace the PF kit 1.
9	T1 pickup clutch failure	Replace the T1 pickup clutch.
10	T1 paper empty sensor failure	Replace the T1 paper empty sensor.
11	Damaged plate gear	Replace the T1 plate gear.
12	Paper feed motor failure	Replace the paper feed motor.
13	High-voltage power supply PCB failure	Replace the high-voltage power supply PCB ASSY.
14	Panel PCB failure	Replace the panel PCB ASSY.
15	Damaged gears in the paper pickup system	Replace the main frame L ASSY.
16	Damaged fuser unit	Replace the fuser unit.
17	Main PCB failure	Replace the main PCB ASSY.

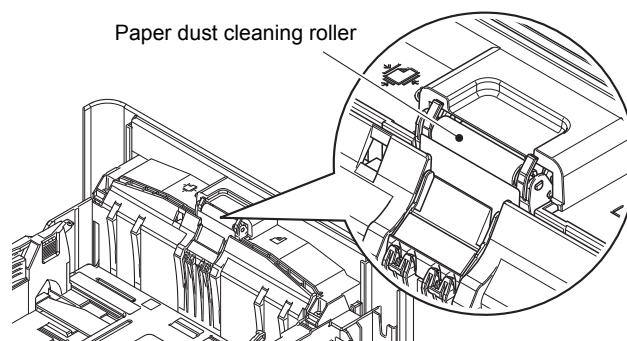

Fig. 2-10

4.2.2 No paper is fed from LT

<User Check>

- Check that the paper is set in the paper tray correctly.
- Check that there is not too much paper set in the paper tray.
- Flip over the paper in the paper tray or rotate the paper 180°.
- Check that the thickness of the paper is 60 to 120 g/m² (paper tray 2 to 4).
- Check that the MP tray, T1 or TT is not set as the paper tray.
- Flip through the paper and reset it in the paper tray.
- Clean the paper pick up roller.
- Install the latest main firmware.

Step	Cause	Remedy
1	Dirt on a paper dust cleaning roller of the paper tray	Clean the appropriate paper dust cleaning roller. (Refer to Fig. 2-10.)
2	Attachment failure of a roller holder ASSY	Reattach the appropriate roller holder ASSY correctly.
3	Connection failure of the paper feed motor harness	Reconnect the paper feed motor harness.
4	Connection failure of an LT paper feed sensor harness	Reconnect the appropriate LT paper feed sensor harness.
5	Connection failure of an LT control PCB flat cable	Reconnect the appropriate LT control PCB flat cable.
6	Connection failure of an LT release clutch harness	Reconnect the appropriate LT release clutch harness.
7	Connection failure of an LT pickup clutch harness	Reconnect the appropriate LT pickup clutch harness.
8	An LT paper empty actuator coming off	Reattach the appropriate LT paper empty actuator.
9	Abrasion of a paper pick up roller	Replace the appropriate PF kit.
10	An LT release clutch failure	Replace the appropriate LT release clutch.
11	An LT pickup clutch failure	Replace the appropriate LT pickup clutch.
12	An LT paper empty sensor failure	Replace the appropriate LT paper empty sensor PCB ASSY.
13	Damaged a plate gear	Replace the appropriate plate gear.
14	Damaged fuser gear	Replace the fuser gear.
15	Damaged an LT/TT connector	Replace the appropriate LT/TT connector.
16	Paper feed motor failure	Replace the paper feed motor.
17	An LT control PCB failure	Replace the appropriate LT control PCB ASSY.
18	Panel PCB failure	Replace the panel PCB ASSY.
19	Damaged LT drive gear system of the machine	Replace the main frame L ASSY.
20	Damaged fuser unit	Replace the fuser unit.
21	Main PCB failure	Replace the main PCB ASSY.

4.2.3 No paper is fed from TT

<User Check>

- Check that the paper is set in the paper tray correctly.
- Check that there is not too much paper set in the paper tray.
- Flip over the paper in the paper tray or rotate the paper 180°.
- Check that the thickness of the paper is 60 to 120 g/m² (paper tray 2 to 5).
- Check that the MP tray, LT or TT are not set as the paper tray.
- Flip through the paper and reset it in the paper tray.
- Clean the paper pick up roller.
- Install the latest main firmware.
- Replace the relay AC cord.
- Turn the power switch of TT OFF and then back ON again.

Step	Cause	Remedy
1	Dirt on a paper dust cleaning roller of the paper tray	Clean the appropriate paper dust cleaning roller. (Refer to Fig. 2-10.)
2	Attachment failure of a roller holder ASSY	Reattach the appropriate roller holder ASSY correctly.
3	Connection failure of the TT motor harness	Reconnect the TT motor harness.
4	Connection failure of a TT paper feed sensor harness	Reconnect the appropriate TT paper feed sensor harness.
5	Connection failure of a TT relay PCB harness	Reconnect the appropriate TT relay PCB harness.
6	Connection failure of the TT control PCB harness	Reconnect the TT control PCB harness.
7	Connection failure of the TT low-voltage power supply PCB harness	Reconnect the TT low-voltage power supply PCB harness.
8	Connection failure of a TT release clutch harness	Reconnect the appropriate TT release clutch harness.
9	Connection failure of a TT pickup clutch harness	Reconnect the appropriate TT pickup clutch harness.
10	Connection failure of a TT jam sensor harness	Reconnect the appropriate TT jam sensor harness.
11	A TT paper empty actuator coming off	Reattach the appropriate TT paper empty actuator.
12	Abrasion of a paper pick up roller	Replace the appropriate PF kit.
13	A TT release clutch failure	Replace the appropriate TT release clutch.
14	A TT pickup clutch failure	Replace the appropriate TT pickup clutch.
15	A TT paper empty sensor failure	Replace the appropriate TT paper empty sensor PCB ASSY.
16	TT balance sensor L/R failure	Replace the TT balance sensor L/R.
17	A TT jam sensor failure	Replace the appropriate TT jam sensor PCB ASSY.
18	Damaged a plate gear	Replace the appropriate plate gear.
19	Damaged an LT/TT connector	Replace the appropriate LT/TT connector.
20	TT motor failure	Replace the TT motor.
21	A TT relay PCB failure	Replace the appropriate TT relay PCB ASSY.
22	TT control PCB failure	Replace the TT control PCB ASSY.
23	Panel PCB failure	Replace the panel PCB ASSY.
24	TT low-voltage power supply PCB failure	Replace the TT low-voltage power supply PCB ASSY.
25	Main PCB failure	Replace the main PCB ASSY.

4.2.4 No paper is fed from MP tray

<User Check>

- Check that the paper is set in the MP tray deeply.
- Check that the thickness of the paper is 60 to 200 g/m².
- Check that the paper tray is not set as the paper tray.

Step	Cause	Remedy
1	MP roller holder ASSY attachment failure	Reattach the MP roller holder ASSY correctly.
2	Connection failure of the paper feed motor harness	Reconnect the paper feed motor harness.
3	Connection failure of the MP paper empty sensor harness	Reconnect the MP paper empty sensor harness.
4	Connection failure of the MP solenoid harness	Reconnect the MP solenoid harness.
5	MP paper empty actuator coming off	Reattach the MP paper empty actuator.
6	Connection failure of the registration front/rear sensor harness	Reconnect the registration front/rear sensor harness.
7	Connection failure of the relay front harness	Reconnect the relay front harness.
8	Connection failure of the HVPS flat cable	Reconnect the HVPS flat cable.
9	Abrasion of the MP paper pick up roller	Replace the PF kit MP.
10	MP solenoid failure	Replace the MP solenoid.
11	MP paper empty sensor failure	Replace the MP paper empty sensor PCB ASSY.
12	Registration front/rear sensor PCB failure	Replace the registration front/rear sensor PCB ASSY.
13	Paper feed motor failure	Replace the paper feed motor.
14	Damaged fuser unit	Replace the fuser unit.
15	Relay front PCB failure	Replace the relay front PCB ASSY.
16	High-voltage power supply PCB failure	Replace the high-voltage power supply PCB ASSY.
17	Main PCB failure	Replace the main PCB ASSY.

4.2.5 Multiple sheets of paper are fed

<User Check>

- Check that there is not too much paper set in each paper tray.
- Check that the paper is set in each paper tray correctly.
- Flip over the paper in each paper tray or rotate the paper 180°.
- Check that the thickness of the paper is 60 to 120 g/m² for paper tray 1 to 5, and 60 to 200 g/m² for the MP tray.
- Flip through the paper and reset it in each paper tray.

Step	Cause	Remedy
1	Abrasion of a separation pad	Replace the appropriate PF kit.

4.2.6 Paper becomes wrinkled

<User Check>

- Check that the paper is set in each paper tray correctly.
- Flip over the paper in each paper tray or rotate the paper 180°.
- Adjust each paper guide according to each paper size.
- Check that the thickness of the paper is 60 to 120 g/m² for paper tray 1 to 5, and 60 to 200 g/m² for the MP tray.
- Check that the paper is not damp.
- Check that there is no dust stuck to the fuser unit.
- Check that the type of paper is appropriate.

Step	Cause	Remedy
1	Eject motor failure	Replace the eject motor.
2	Fuser unit failure	Replace the fuser unit.
3	Damaged gears in the ejecting system	Replace the main frame L ASSY.

4.2.7 Paper is fed at an angle

<User Check>

- Check that the paper is set in each paper tray correctly.
- Flip over the paper in each paper tray or rotate the paper 180°.
- Adjust each paper guide according to each paper size.
- Check that the thickness of the paper is 60 to 120 g/m² for paper tray 1 to 5, and 60 to 200 g/m² for MP tray.
- Check that there is not too much paper set in each paper tray.
- Check that each type of paper is appropriate.
- Clean each paper pick up roller.
- Check that the green envelope lever is not lowered on only one side.
- Replace the drum unit.
- Replace the toner cartridge.

Step	Cause	Remedy
1	Tray guide coming off on the machine side	Reattach the tray guide on the machine side. Refer to the figure below.
2	One-side abrasion of the paper pick up rollers	Replace the PF kit.
3	Damaged gears in the paper feeding system	Replace the main frame L ASSY.

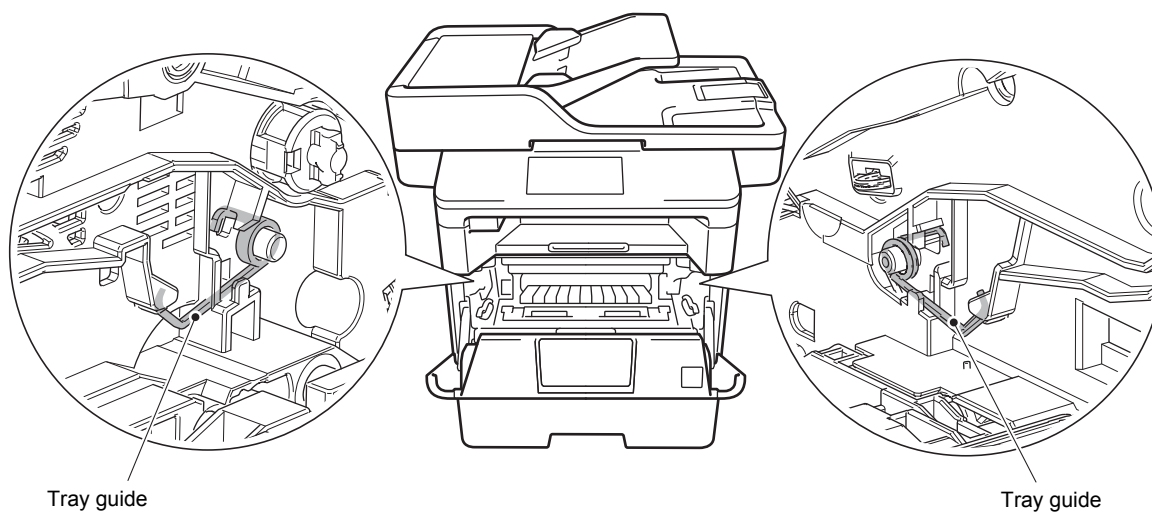

Fig. 2-11

4.2.8 Paper is curled

<User Check>

- Check that the paper specified in driver settings is matched to the paper set.
- Select "Reduce Paper Curl" in the driver.
- Check that the paper is set in each paper tray correctly.
- Open the back cover and try printing with straight paper ejection mode.

Step	Cause	Remedy
1	Fuser unit failure	Replace the fuser unit.
2	Main PCB failure	Replace the main PCB ASSY.

4.2.9 Duplex printing is not possible

<User Check>

- Close the back cover completely.
- Set the duplex tray correctly.
- Set the driver setting to duplex printing.
- Use A4 or Letter paper specified by the manufacturer.

Step	Cause	Remedy
1	Back cover failure	Replace the back cover.
2	Eject motor failure	Replace the eject motor.
3	Back cover/duplex tray sensor failure	Replace the back cover/duplex tray sensor.
4	Duplex tray failure	Replace the duplex tray.
5	Main PCB failure	Replace the main PCB ASSY.
6	Damaged gears in the ejecting system	Replace the main frame L ASSY.

4.2.10 Paper jam

■ Paper jams in the paper tray 1

<User Check>

- Check that the paper is set in the paper tray correctly.
- Flip over the paper in the paper tray or rotate the paper 180°.
- Adjust the paper guide according to the paper size.
- Check that there is not too much paper set in the paper tray.
- Check that the thickness of the paper is 60 to 120 g/m² for paper tray 1.
- Flip through the paper and reset it in the paper tray.

Step	Cause	Remedy
1	Foreign object around the paper tray	Remove the foreign object.
2	Paper dust cleaning roller attachment failure	Reattach the paper dust cleaning roller.
3	Paper feed actuator coming off	Reattach the paper feed actuator.
4	Registration front actuator coming off	Reattach the registration front actuator.
5	Connection failure of the registration front/rear sensor harness	Reconnect the registration front/rear sensor harness.
6	Connection failure of the registration clutch harness	Reconnect the registration clutch harness.
7	Connection failure of the T1 paper feed sensor harness	Reconnect the T1 paper feed sensor harness.
8	Connection failure of a release clutch harness	Reconnect the appropriate release clutch harness.
9	Connection failure of the HVPS flat cable	Reconnect the HVPS flat cable.
10	HVPS flat cable breakage	Replace the HVPS flat cable.
11	A release clutch failure	Replace the appropriate release clutch.
12	Registration front sensor failure	Replace the registration front/rear sensor PCB ASSY.
13	T1 paper feed sensor failure	Replace the T1 paper feed sensor PCB ASSY.
14	Registration clutch failure	Replace the registration clutch.
15	Paper feed motor failure	Replace the paper feed motor.
16	Relay front PCB failure	Replace the relay front PCB ASSY.
17	High-voltage power supply PCB failure	Replace the high-voltage power supply PCB ASSY.
18	Damaged gears in the paper feeding system	Replace the main frame L ASSY.
19	Damaged fuser unit	Replace the fuser unit.
20	Main PCB failure	Replace the main PCB ASSY.

■ Paper jams in LT path

<User Check>

- Check that the paper is set in each LT correctly.
- Flip over the paper in each LT or rotate the paper 180°.
- Adjust each paper guide according to the paper size.
- Check that there is not too much paper set in each LT.
- Check that the thickness of the paper is 60 to 120 g/m² for paper tray 2 to 4.
- Flip through the paper and reset it in each LT.
- Install the latest main firmware.

Step	Cause	Remedy
1	Foreign object around an LT	Remove the foreign object.
2	A paper dust cleaning roller attachment failure	Reattach the appropriate paper dust cleaning roller.
3	An LT paper feed actuator coming off	Reattach the appropriate LT paper feed actuator.
4	Registration front actuator coming off	Reattach the registration front actuator.
5	Connection failure of an LT paper feed sensor harness	Reconnect the appropriate LT paper feed sensor harness.
6	Connection failure of an LT release clutch harness	Reconnect the appropriate LT release clutch harness.
7	Connection failure of an LT control PCB harness	Reconnect the appropriate LT control PCB harness.
8	An LT paper feed sensor failure	Replace the appropriate LT paper feed sensor.
9	An LT release clutch failure	Replace the appropriate LT release clutch.
10	Paper feed motor failure	Replace the paper feed motor.
11	An LT control PCB failure	Replace the appropriate LT control PCB ASSY.
12	Damaged LT drive gear system of the machine	Replace the main frame L ASSY.
13	Damaged fuser unit	Replace the fuser unit.
14	Main PCB failure	Replace the main PCB ASSY.

■ Paper jams in TT path

<User Check>

- Check that the paper is set in each tray in the TT correctly.
- Flip over the paper or rotate the paper 180°.
- Adjust the paper guide according to the paper size.
- Check that there is not too much paper set.
- Check that the thickness of the paper is 60 to 120 g/m² for paper tray 2 to 5.
- Flip through the paper and reset it in each paper tray.
- Install the latest main firmware.

Step	Cause	Remedy
1	Foreign object in the TT paper feeding path	Remove the foreign object.
2	A paper dust cleaning roller attachment failure	Reattach the appropriate paper dust cleaning roller.
3	A TT paper feed actuator coming off	Reattach the appropriate TT paper feed actuator.
4	A TT jam actuator coming off	Reattach the appropriate TT jam actuator.
5	Connection failure of a TT jam sensor harness	Reconnect the appropriate TT jam sensor harness.
6	Connection failure of a TT paper feed sensor harness	Reconnect the appropriate TT paper feed sensor harness.
7	Connection failure of a TT release clutch harness	Reconnect the appropriate TT release clutch harness.
8	Connection failure of a TT relay PCB harness	Reconnect the appropriate TT relay PCB harness.
9	Connection failure of the TT control PCB harness	Reconnect the TT control PCB harness.
10	A TT paper feed sensor failure	Replace the appropriate TT paper feed sensor.
11	A TT release clutch failure	Replace the appropriate TT release clutch.
12	TT balance sensor L/R failure	Replace the TT balance sensor L/R.
13	A TT jam sensor failure	Replace the appropriate TT jam sensor PCB ASSY.
14	TT motor failure	Replace the TT motor.
15	A TT relay PCB failure	Replace the appropriate TT relay PCB ASSY.
16	TT control PCB failure	Replace the TT control PCB ASSY.
17	Main PCB failure	Replace the main PCB ASSY.

■ Paper jams in MP tray

<User Check>

- Check that the paper is set in the MP tray correctly.
- Flip over the paper in the MP tray or rotate the paper 180°.
- Adjust the paper guide according to the paper size.
- Check that the thickness of the paper is 60 to 200 g/m².
- Flip through the paper and reset it in the MP tray.

Step	Cause	Remedy
1	Foreign object around the MP tray	Remove the foreign object.
2	Connection failure of the registration front/rear sensor harness	Reconnect the registration front/rear sensor harness.
3	Registration front actuator coming off	Reattach the registration front actuator.
4	Connection failure of the registration clutch harness	Reconnect the registration clutch harness.
5	Connection failure of the HVPS flat cable	Reconnect the HVPS flat cable.
6	Connection failure of the relay front harness	Reconnect the relay front harness.
7	Registration front sensor failure	Replace the registration front/rear sensor PCB ASSY.
8	Registration clutch failure	Replace the registration clutch.
9	Paper feed motor failure	Replace the paper feed motor.
10	Relay front PCB failure	Replace the relay front PCB ASSY.
11	High-voltage power supply PCB failure	Replace the high-voltage power supply PCB ASSY.
12	Damaged gears in the paper feeding system	Replace the main frame L ASSY.
13	Damaged fuser unit	Replace the fuser unit.
14	Main PCB failure	Replace the main PCB ASSY.

■ **Paper jams in the feeding path in the center of the machine**

<User Check>

- Check that the paper is set in each paper tray correctly.
- Flip over the paper in each paper tray or rotate the paper 180°.
- Adjust the paper guide according to the paper size.
- Check that there is not too much paper set in each paper tray.
- Check that the thickness of the paper is 60 to 120 g/m² for paper tray 1 to 5, and 60 to 200 g/m² for the MP tray.
- Flip through the paper and reset it in each paper tray.
- Replace the drum unit.

Step	Cause	Remedy
1	Foreign object inside the machine	Remove the foreign object.
2	Eject actuator coming off	Reattach the eject actuator.
3	Connection failure of the eject sensor harness	Reconnect the eject sensor harness.
4	Fuser cover attachment failure	Reattach the fuser cover.
5	Damaged fuser gear	Replace the fuser gear.
6	Eject sensor failure	Replace the eject sensor PCB ASSY.
7	Registration rear sensor failure	Replace the registration front/rear sensor PCB ASSY.
8	Paper feed motor failure	Replace the paper feed motor.
9	Damaged gears in the paper feeding system	Replace the main frame L ASSY.
10	Fuser unit failure	Replace the fuser unit.
11	Main PCB failure	Replace the main PCB ASSY.

■ Paper jams in the ejecting section

<User Check>

- Check that the paper is set in each paper tray correctly.
- Flip over the paper in each paper tray or rotate the paper 180°.
- Adjust the paper guide according to the paper size.
- Check that there is not too much paper set in each paper tray.
- Check that the thickness of the paper is 60 to 120 g/m² for paper tray 1 to 5, and 60 to 200 g/m² for the MP tray.
- Flip through the paper and reset it in each paper tray.

Step	Cause	Remedy
1	Foreign object in the rear of the machine	Remove the foreign object.
2	Eject actuator coming off	Reattach the eject actuator.
3	Connection failure of the eject sensor harness	Reconnect the eject sensor harness.
4	Connection failure of the eject motor harness	Reconnect the eject motor harness.
5	Fuser cover attachment failure	Reattach the fuser cover.
6	Eject sensor failure	Replace the eject sensor PCB ASSY.
7	Eject motor failure	Replace the eject motor.
8	Damaged gears in the ejecting system	Replace the main frame L ASSY.
9	Fuser unit failure	Replace the fuser unit.
10	Main PCB failure	Replace the main PCB ASSY.

■ Paper jams in the duplex tray

<User Check>

- Flip over the paper in each paper tray or rotate the paper 180°.
- Check that the thickness of the paper is 60 to 105 g/m² for the duplex tray.
- Flip through the paper and reset it in each paper tray.
- Use A4 or Letter paper (specified by the manufacturer).

Step	Cause	Remedy
1	Foreign object in the duplex paper feeding system	Remove the foreign object.
2	Fuser cover attachment failure	Reattach the fuser cover.
3	Back cover failure	Replace the back cover.
4	Duplex tray failure	Replace the duplex tray.
5	Damaged gears in the duplex paper feeding system	Replace the main frame L ASSY.
6	Main PCB failure	Replace the main PCB ASSY.

4.3 Troubleshooting for Image Defects

4.3.1 Image defect examples

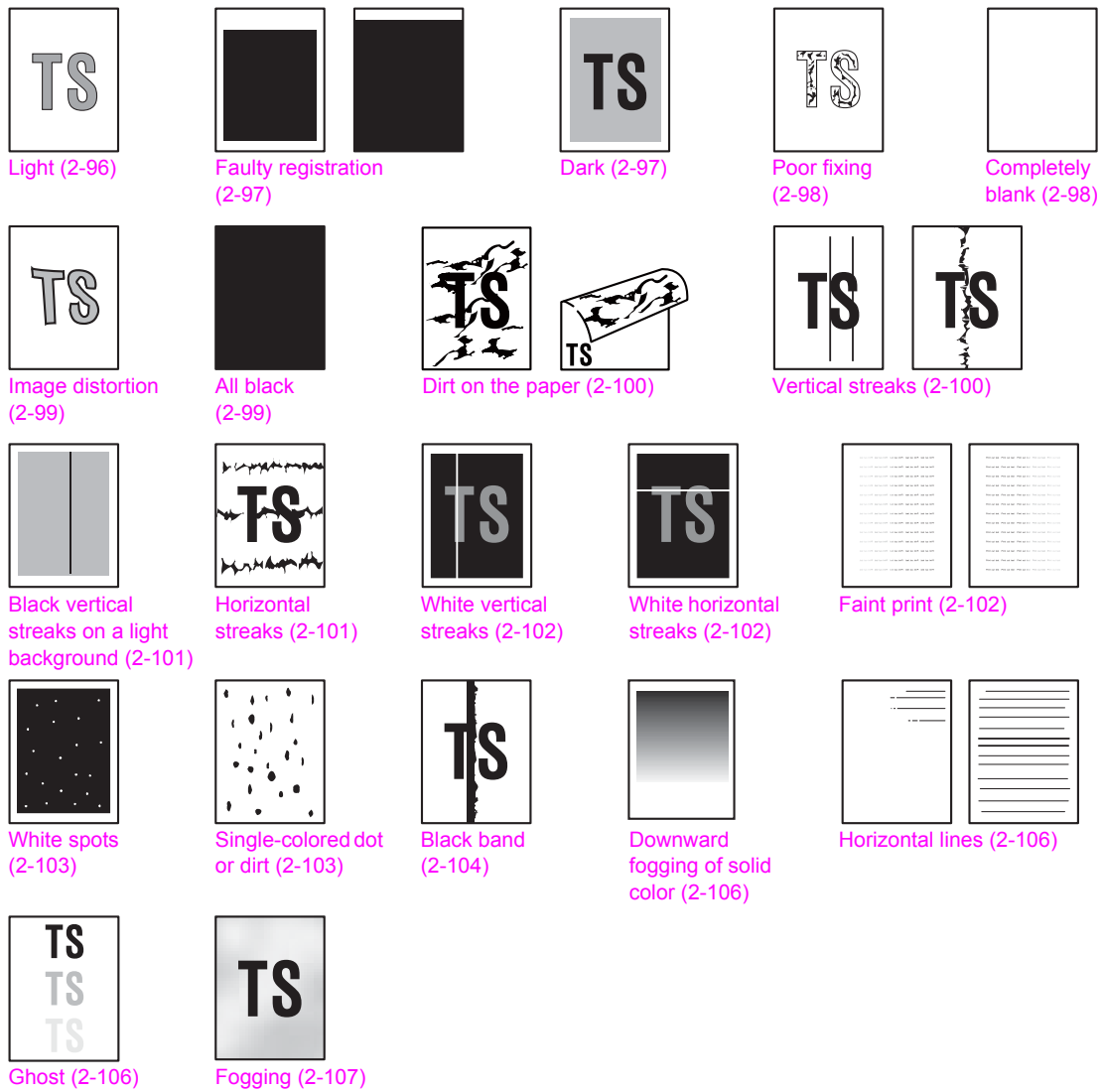

Fig. 2-12

4.3.2 Troubleshooting according to image defect

End users can solve problems related to image defect as long as they follow the User Check items. If the problem still cannot be solved, implement each procedure according to the step numbers in the tables below.

■ Light



<User Check>

- Check the usage environment of the machine. Using the machine in hot-humid or cold-dry conditions can cause this problem.
- If the whole page is light, toner save mode may be ON. Turn OFF the toner save mode.
- Replace the drum unit with a new one.
- Replace the toner cartridge with a new one.
- Turn ON the power switch, and leave the machine for a while (condensation).
- Check that the paper is not damp.
- Use specified paper.

Step	Cause	Remedy
1	Dirt on the electrodes of the drum unit and those of the machine	Clean the electrodes of the drum unit and those of the machine. (Refer to Fig. 2-8 and Fig. 2-9 .)
2	Dirt on the electrodes of the toner cartridge and those of the machine	Clean the electrodes of the toner cartridge and those of the machine. (Refer to Fig. 2-8 and Fig. 2-9 .)
3	Dirt on the electrodes of the machine	Clean the electrodes of the machine. (Refer to Fig. 2-9 .)
4	Fuser unit failure	Replace the fuser unit.
5	High-voltage power supply PCB failure	Replace the high-voltage power supply PCB ASSY.
6	Main PCB failure	Replace the main PCB ASSY.
7	Laser unit failure	Replace the laser unit.

■ Faulty registration



<User Check>

- Check that the appropriate paper type is selected in the driver.
- Install the latest main firmware.

Step	Cause	Remedy
1	Wrong adjusted value of laser unit entered	Refer to “3.1 Entering Adjusted Value of Laser Unit” in Chapter 4, and enter the adjusted value of the laser unit correctly.
2	Entered adjusted value for TT left-end printing position / upper-end printing position was wrong.	Refer to “1.3.13 Change USB No. return value / Adjust left-end print position / Adjust upper-end print position / Set HEXDUMP Mode (function code: 45)” in Chapter 5 to adjust the writing start position.
3	Registration rear actuator coming off	Reattach the registration rear actuator.
4	Distortion at TT assembly	Reattach the TT.
5	Laser unit failure	Replace the laser unit.
6	Main PCB failure	Replace the main PCB ASSY.

■ Dark



<User Check>

- Check the usage environment of the machine. Using the machine in hot-humid or cold-dry conditions can cause this problem.
- If a new toner cartridge has been detected, check that it was not replaced with another toner cartridge.
- Clean the corona wire of the drum unit.
- Replace the drum unit with a new one.
- Replace the toner cartridge with a new one.

Step	Cause	Remedy
1	Dirt on the electrodes of the drum unit and those of the machine	Clean the electrodes of the drum unit and those of the machine. (Refer to Fig. 2-8 and Fig. 2-9.)
2	Dirt on the electrodes of the toner cartridge and those of the machine	Clean the electrodes of the toner cartridge and those of the machine. (Refer to Fig. 2-8 and Fig. 2-9.)
3	Dirt on the electrodes of the machine	Clean the electrodes of the machine. (Refer to Fig. 2-9.)
4	High-voltage power supply PCB failure	Replace the high-voltage power supply PCB ASSY.
5	Main PCB failure	Replace the main PCB ASSY.
6	Laser unit failure	Replace the laser unit.

■ Poor fixing

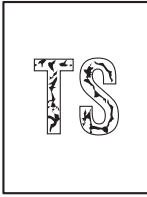

<User Check>

- Check the usage environment of the machine. Using the machine in hot-humid or cold-dry conditions can cause this problem.
- Clean the corona wire of the drum unit.
- Replace the drum unit with a new one.
- Replace the toner cartridge with a new one.

Step	Cause	Remedy
1	Dirt on the electrodes of the toner cartridge and those of the machine	Clean the electrodes of the toner cartridge and those of the machine. (Refer to Fig. 2-8 and Fig. 2-9.)
2	Fuser unit failure	Replace the fuser unit.
3	High-voltage power supply PCB failure	Replace the high-voltage power supply PCB ASSY.
4	Low-voltage power supply PCB failure	Replace the low-voltage power supply PCB ASSY.
5	Laser unit failure	Replace the laser unit.
6	Main PCB failure	Replace the main PCB ASSY.

■ Completely blank



<User Check>

- Clean the corona wire of the drum unit.
- Replace the drum unit with a new one.
- Replace the toner cartridge with a new one.
- Install the latest main firmware.

Step	Cause	Remedy
1	Dirt on the electrodes of the drum unit and those of the machine	Clean the electrodes of the drum unit and those of the machine. (Refer to Fig. 2-8 and Fig. 2-9.)
2	Dirt on the electrodes of the toner cartridge and those of the machine	Clean the electrodes of the toner cartridge and those of the machine. (Refer to Fig. 2-8 and Fig. 2-9.)
3	Connection failure of the laser unit flat cable	Reconnect the laser unit flat cable.
4	Laser unit attachment failure	Reattach the laser unit.
5	Laser unit flat cable failure	Replace the laser unit flat cable.
6	Dirt on the electrodes of the machine	Clean the electrodes of the machine. (Refer to Fig. 2-9.)
7	Laser unit failure	Replace the laser unit.
8	Main PCB failure	Replace the main PCB ASSY.

■ Image distortion



Step	Cause	Remedy
1	Laser unit attachment failure	Reattach the laser unit.
2	Laser unit failure	Replace the laser unit.
3	Main PCB failure	Replace the main PCB ASSY.

■ All black



<User Check>

- Clean the corona wire of the drum unit.
- Replace the drum unit with a new one.

Step	Cause	Remedy
1	Dirt on the electrodes of the drum unit and those of the machine	Clean the electrodes of the drum unit and those of the machine. (Refer to Fig. 2-8 and Fig. 2-9.)
2	Laser unit flat cable failure	Replace the laser unit flat cable.
3	Dirt on the electrodes of the machine	Clean the electrodes of the machine. (Refer to Fig. 2-9.)
4	High-voltage power supply PCB failure	Replace the high-voltage power supply PCB ASSY.
5	Laser unit failure	Replace the laser unit.
6	Main PCB failure	Replace the main PCB ASSY.

■ **Dirt on the paper**

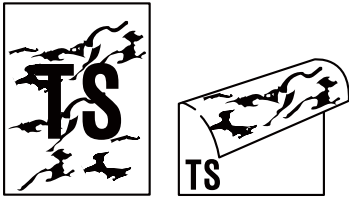

<User Check>

- This problem may disappear after printing multiple sheets of paper.
- Replace the drum unit with a new one.

Step	Cause	Remedy
1	Dirt on the paper feeding system	Wipe off the dirt.
2	Dirt on the fuser unit	Replace the fuser unit.
3	High-voltage power supply PCB failure	Replace the high-voltage power supply PCB ASSY.

■ **Vertical streaks**



<User Check>

- Clean the corona wire of the drum unit.
- Return the corona wire cleaning tab to the "▲" position.
- This problem may disappear after printing multiple sheets of paper.
- Refer to <How to clean the drum unit> to remove the dirt from the exposure drum using a cotton applicator.
- Replace the drum unit with a new one.
- Replace the toner cartridge with a new one.

Step	Cause	Remedy
1	Dirt on the paper feeding system	Wipe off the dirt.
2	FG harnesses or FG plate attachment failure (not grounded correctly)	Retighten the screws to secure the FG harnesses or FG plate. Fix the bent tray ground spring of the paper tray (Refer to the figure below).
3	Dirt on the fuser unit	Replace the fuser unit.
4	Laser unit failure	Replace the laser unit.

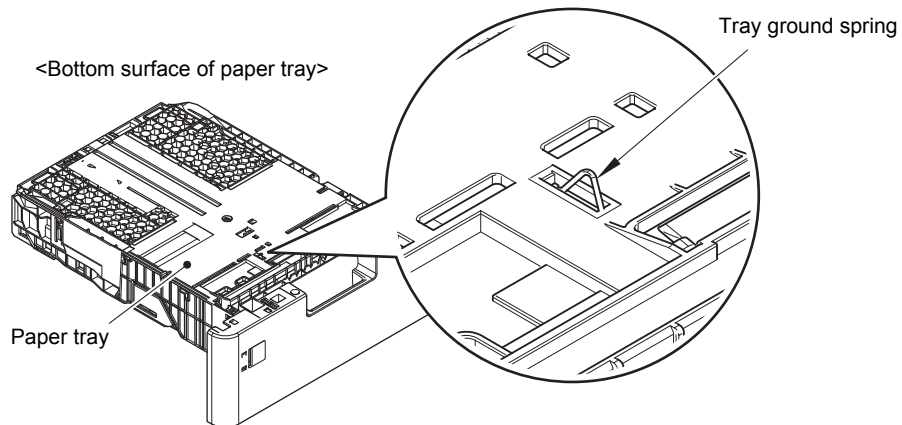
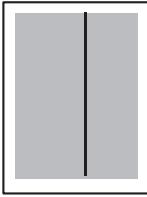

Fig. 2-13

■ Black vertical streaks on a light background



<User Check>

- Clean the corona wire of the drum unit.
- This problem may disappear after printing multiple sheets of paper.
- Refer to < [How to clean the drum unit](#) > to remove the dirt from the exposure drum using a cotton applicator.
- Turn ON the power switch, and leave the machine for a while (condensation).
- Replace the drum unit with a new one.
- Replace the toner cartridge with a new one.

Step	Cause	Remedy
1	Dirty charge electrodes	Clean the electrodes of the drum unit and those of the machine. (Refer to Fig. 2-8 and Fig. 2-9 .)
2	Laser unit failure	Replace the laser unit.

■ Horizontal streaks



<User Check>

- Clean the corona wire of the drum unit.
- This problem may disappear after printing multiple sheets of paper.
- Refer to < [How to clean the drum unit](#) > to remove the dirt from the exposure drum using a cotton applicator.
- Replace the drum unit with a new one.
- Replace the toner cartridge with a new one.

Step	Cause	Remedy
1	Dirty charge electrodes	Clean the electrodes of the drum unit and those of the machine. (Refer to Fig. 2-8 and Fig. 2-9 .)
2	FG harnesses or FG plate attachment failure (not grounded correctly)	Retighten the screws to secure the FG harnesses or FG plate. Fix the bent tray ground spring of the paper tray. (Refer to Fig. 2-13 .)
3	Scratch or dirt on the fuser unit	Replace the fuser unit.
4	High-voltage power supply PCB failure	Replace the high-voltage power supply PCB ASSY.

■ White vertical streaks



<User Check>

- Clean the corona wire of the drum unit.
- Check that there is no dust on the toner cartridge.
- Refer to < [How to clean the drum unit](#)> to remove the dirt from the exposure drum using a cotton applicator.
- Replace the drum unit with a new one.
- Replace the toner cartridge with a new one.

Step	Cause	Remedy
1	Dirty charge electrodes	Clean the electrodes of the drum unit and those of the machine. (Refer to Fig. 2-8 and Fig. 2-9 .)
2	Laser unit failure	Replace the laser unit.

■ White horizontal streaks



<User Check>

- This problem may disappear after printing multiple sheets of paper.
- Replace the drum unit with a new one.
- Replace the toner cartridge with a new one.

Step	Cause	Remedy
1	Dirty charge electrodes	Clean the electrodes of the drum unit and those of the machine. (Refer to Fig. 2-8 and Fig. 2-9 .)
2	Scratch or dirt on the fuser unit	Replace the fuser unit.
3	High-voltage power supply PCB failure	Replace the high-voltage power supply PCB ASSY.

■ Faint print

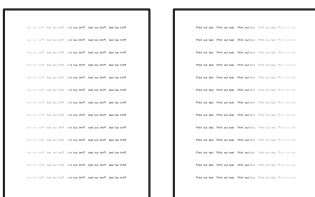

<User Check>

- Check that the machine is positioned on a level surface.
- Replace the drum unit with a new one.
- Replace the toner cartridge with a new one.

Step	Cause	Remedy
1	Laser unit failure	Replace the laser unit.
2	Fuser unit failure	Replace the fuser unit.
3	Main PCB failure	Replace the main PCB ASSY.

■ White spots

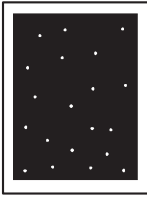

<User Check>

- Check that the main fan is not clogged.
- Refer to < [How to clean the drum unit](#) > to remove the dirt from the exposure drum using a cotton applicator.
- Replace the drum unit with a new one.
- Replace the toner cartridge with a new one.

Step	Cause	Remedy
1	Dirt on the paper dust cleaning roller of the paper tray	Refer to the Fig. 2-10 to clean the paper dust cleaning roller.
2	Clogged filter	Clean the filter.
3	Scratch or dirt on the fuser unit	Replace the fuser unit.
4	High-voltage power supply PCB failure	Replace the high-voltage power supply PCB ASSY.

Note:

- Image defects which appear periodically may be caused by failure of rollers. Refer to the table below and determine the cause based on the diameter of the rollers or the pitch at which defects appear on the image.

<Pitch appears in the image and rollers >

Part name	Pitch at which defects appear in the image
Develop roller	45.5 mm
Exposure drum	94.2 mm
Heat film in the fuser unit	104 mm
Pressure roller in the fuser unit	94 mm

■ Single-colored dot or dirt

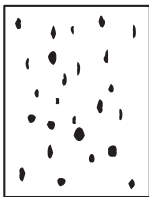

<User Check>

- Check that the paper is not damp.
- Refer to < [How to clean the drum unit](#) > to remove the dirt from the exposure drum using a cotton applicator.
- Replace the drum unit with a new one.
- Replace the toner cartridge with a new one.

Step	Cause	Remedy
1	Dirt on the paper dust cleaning roller of the paper tray	Refer to the Fig. 2-10 to clean the paper dust cleaning roller.
2	Clogged filter	Clean the filter.
3	Scratch or dirt on the fuser unit	Replace the fuser unit.
4	High-voltage power supply PCB failure	Replace the high-voltage power supply PCB ASSY.

Note:

- Image defects which appear periodically may be caused by failure of rollers. Refer to the table above and determine the cause based on the diameter of the rollers or the pitch at which defects appear on the image.

■ **Black band**



<User Check>

- Clean the corona wire of the drum unit.
- Return the corona wire cleaning tab to the "▲" position.
- This problem may disappear after printing multiple sheets of paper.
- Refer to < [How to clean the drum unit](#) > to remove the dirt from the exposure drum using a cotton applicator.
- Replace the drum unit with a new one.
- Replace the toner cartridge with a new one.

Step	Cause	Remedy
1	FG harnesses or FG plate attachment failure (not grounded correctly)	Retighten the screws to secure the FG harnesses or FG plate. Fix the bent tray ground spring of the paper tray. (Refer to Fig. 2-13.)
2	Laser unit failure	Replace the laser unit.

< How to clean the drum unit (the shape of the drum is different from the actual one) >

- (1) Remove the toner cartridge from the drum unit. Check where the image distortion occurs by placing the print sample in front of the drum unit.

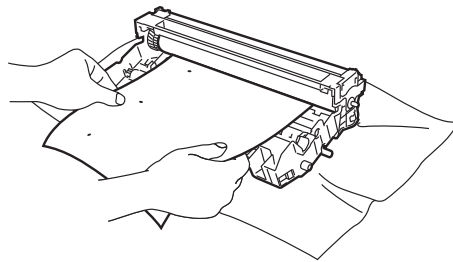
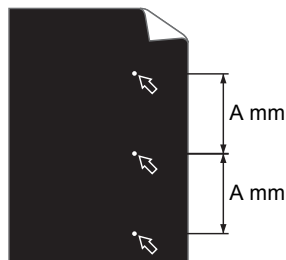
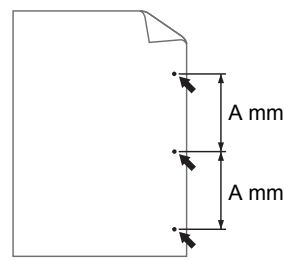

Fig. 2-14

< Examples of image distortion >



White dots repeat in A mm distance on the black page with printed images.



Black dots repeat in A mm distance on the page.

Fig. 2-15

Refer to the table < [Pitch appears in the image and rollers](#) > for what represents the value A.

- (2) Turn the drum unit gear by hand so that the glued exposure drum surface comes to the front.

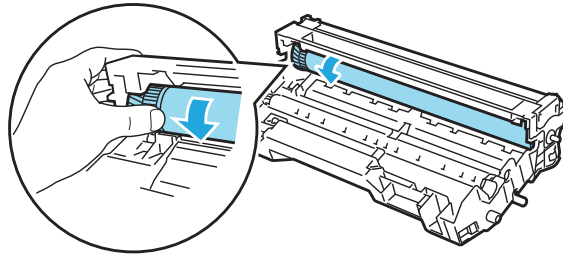

Fig. 2-16

- (3) If the position of the dirt on the drum and the dots on the print sample matches, wipe the exposure drum surface with a cotton bud until the dirt and paper dust comes off.

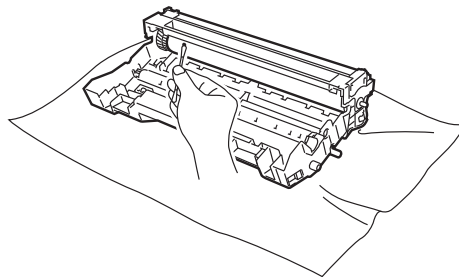

Fig. 2-17

Note:

- Do not clean the exposure drum surface with anything sharp like a ball pointed pen.

■ Downward fogging of solid color



<User Check>

- Replace the toner cartridge with a new one.

Step	Cause	Remedy
1	High-voltage power supply PCB failure	Replace the high-voltage power supply PCB ASSY.
2	Main PCB failure	Replace the main PCB ASSY.

■ Horizontal lines

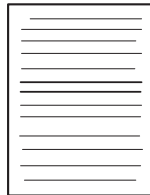

<User Check>

- This problem may disappear after printing multiple sheets of paper.
- Refer to < [How to clean the drum unit](#) > to remove the dirt from the exposure drum using a cotton applicator.
- Replace the drum unit with a new one.
- Replace the toner cartridge with a new one.

Step	Cause	Remedy
1	Dirty charge electrodes	Clean the electrodes of the drum unit and those of the machine. (Refer to Fig. 2-8 and Fig. 2-9 .)
2	Scratch or dirt on the fuser unit	Replace the fuser unit.
3	High-voltage power supply PCB failure	Replace the high-voltage power supply PCB ASSY.

■ Ghost



<User Check>

- Check the usage environment of the machine. Using the machine in hot-humid or cold-dry conditions can cause this problem.
- Check that the appropriate paper type is selected in the driver.
- Select "Improve Toner Fixing" in the driver.
- Replace the drum unit with a new one.

Step	Cause	Remedy
1	Scratch or dirt on the fuser unit	Replace the fuser unit.
2	High-voltage power supply PCB failure	Replace the high-voltage power supply PCB ASSY.

■ Fogging



<User Check>

- Check the usage environment of the machine. Using the machine in hot-humid or cold-dry conditions can cause this problem.
- Check that the acid paper is not used.
- This problem may disappear after printing multiple sheets of paper.
- Replace the toner cartridge with a new one.
- Replace the drum unit with a new one.

Step	Cause	Remedy
1	Toner amount detection sensor PCB (light reception) failure	Replace the toner amount detection sensor PCB ASSY (light reception).
2	Relay front PCB failure	Replace the relay front PCB ASSY.
3	High-voltage power supply PCB failure	Replace the high-voltage power supply PCB ASSY.
4	Main PCB failure	Replace the main PCB ASSY.

Note:

- This problem tends to occur when the life of the drum unit or toner cartridge is expiring.

4.4 Troubleshooting for Software Problems

End users can solve problems related to software, for instance, printing is not possible from a computer although test print or Printer Setting print can be performed from the machine, as long as they follow the User Check items. If the problem still cannot be solved, implement each procedure according to the step numbers in the tables below.

4.4.1 Cannot receive data

<User Check>

- Check that the USB cable or LAN cable is not damaged.
- When using an interface switch, check that the correct machine is selected.
- Check the relevant section in the online User's Guide.
- Check the driver settings.
- Reset the machine to the default settings. (Refer to the online User's Guide.)

Step	Cause	Remedy
1	Machine connection	For Macintosh, check the Product ID*. When it is wrong, update the firmware.
2	Main PCB failure	Replace the main PCB ASSY.

* Check the Product ID on a Macintosh according to the following procedure:

- (1) Select "About This Mac" from the "Apple" menu.
- (2) Press the "More Info..." button in the "About This Mac" dialog box.
- (3) Select "USB" at the bottom of "Hardware" in the "Content" on the left side of the screen.
- (4) Select "DCP-XXXX, MFC-XXXX" in the "USB Device Tree".
- (5) Check the "Product ID" under "DCP-XXXX, MFC-XXXX".

Product ID (hexadecimal)

- DCP-L5500D series : 0398h
- DCP-L5500DN series : 0399h
- DCP-L5502DN7 : 039Ah
- DCP-L5600DN series : 039Bh
- DCP-L5602DN : 039Ch
- DCP-L5650DN series : 039Dh
- DCP-L5652DN : 039Eh
- DCP-L6600DW series : 039Fh
- MFC-8530DN : 03A2h
- MFC-8535DN : 03A3h
- MFC-8540DN : 03A6h
- MFC-8550DN : 03A4h
- MFC-L5700DN series : 03A0h
- MFC-L5700DW series : 03C6h
- MFC-L5702DN : 03A1h
- MFC-L5702DW : 03C7h
- MFC-L5750DW series : 03A5h
- MFC-L5755DW series : 03B2h
- MFC-L5800DW series : 03A7h
- MFC-L5802DW : 03A8h
- MFC-L5850DW series : 03A9h
- MFC-L5900DW series : 03AAh
- MFC-L5902DW : 03ABh
- MFC-L6700DW series : 03ACh
- MFC-L6702DW : 03ADh
- MFC-L6750DW series : 03AEh
- MFC-L6800DW series : 03AFh
- MFC-L6900DW series : 03B0h
- MFC-L6902DW : 03B1h

4.5 Troubleshooting for Network Problems

4.5.1 Cannot print via network connection

<User Check>

- Check the relevant section in the Network Setting Guide.
- Check the network connection.
- Reset the network. (Refer to the online User's Guide.)
- Check the LAN cable.

Step	Cause	Remedy
1	Wireless LAN PCB failure	Replace the wireless LAN PCB.
2	Deformed LAN terminal pin Main PCB failure	Replace the main PCB ASSY.

4.5.2 Cannot connect to access point

<User Check>

- Check the wireless LAN settings.
- Check the access point settings.
- Change the machine installation location.
- Set the access point manually.

Step	Cause	Remedy
1	Wireless LAN PCB failure	Replace the wireless LAN PCB.
2	Main PCB failure	Replace the main PCB ASSY.

4.6 Troubleshooting for Control Panel Problems

4.6.1 Nothing is displayed on the LCD

<User Check>

- Turn the power switch OFF and then ON again.

Step	Cause	Remedy
1	Connection failure of the panel flat cable	Reconnect the panel flat cable.
2	Connection failure of the low-voltage power supply harness	Reconnect the low-voltage power supply harness.
3	AC cord failure	Replace the AC cord.
4	LCD relay PCB failure (For 3.7 inch models only)	Replace the LCD relay PCB ASSY. (For 3.7 inch models only)
5	Panel flat cable failure	Replace the panel flat cable.
6	LCD failure	Replace the LCD.
7	Panel PCB failure	Replace the LCD panel ASSY.
8	Low-voltage power supply PCB failure	Replace the low-voltage power supply PCB ASSY.
9	Main PCB failure	Replace the main PCB ASSY.

4.6.2 Nothing is displayed on the LED

<User Check>

- Turn the power switch OFF and then ON again.

Step	Cause	Remedy
1	Connection failure of the key PCB flat cable	Reconnect the key PCB flat cable.
2	Panel PCB failure	Replace the panel PCB ASSY.
3	Key PCB failure	Replace the panel unit.
4	Main PCB failure	Replace the main PCB ASSY.

4.6.3 Control panel is inoperable

<User Check>

- Turn the power switch OFF and then ON again.

Step	Cause	Remedy
1	Connection failure of the panel flat cable	Reconnect the panel flat cable.
2	Panel PCB failure	Replace the panel PCB ASSY.
3	Touch panel failure	Replace the touch panel ASSY.
4	Low-voltage power supply PCB failure	Replace the low-voltage power supply PCB ASSY.
5	Key PCB failure	Replace the panel unit.
6	Main PCB failure	Replace the main PCB ASSY.

4.7 Troubleshooting for Toner and Drum Problems

4.7.1 New toner is not detected

<User Check>

- Check that the packaged toner cartridge is not set.
- Check that a new (not used) toner cartridge is set.
- Check that the genuine toner cartridge is set.

Step	Cause	Remedy
1	New toner actuator coming off	Reattach the new toner actuator.
2	Connection failure of the relay front harness	Reconnect the relay front harness.
3	Relay front PCB failure	Replace the relay front PCB ASSY.
4	Main PCB failure	Replace the main PCB ASSY.

4.7.2 Toner cartridge cannot be recognized

<User Check>

- Set the toner cartridge correctly.
- Replace the toner cartridge with a new one.

Step	Cause	Remedy
1	Toner amount detection sensor PCB (light reception) failure	Replace the toner amount detection sensor PCB ASSY (light reception).
2	Relay front PCB failure	Replace the relay front PCB ASSY.
3	Main PCB failure	Replace the main PCB ASSY.

4.7.3 Error message prompting toner cartridge replacement does not disappear

<User Check>

- Check that a new (not used) toner cartridge is set.
- Check that the genuine toner cartridge is set.

Step	Cause	Remedy
1	New toner actuator coming off	Reattach the new toner actuator.
2	Connection failure of the relay front harness	Reconnect the relay front harness.
3	Relay front PCB failure	Replace the relay front PCB ASSY.
4	Main PCB failure	Replace the main PCB ASSY.

4.7.4 Drum error

<User Check>

- Clean the corona wire of the drum unit.
- Replace the drum unit with a new one.

Step	Cause	Remedy
1	Dirt on the electrodes of the drum unit and those of the machine	Clean the electrodes of the drum unit and those of the machine. (Refer to Fig. 2-8 and Fig. 2-9.)
2	Dirt on the high-voltage power supply PCB terminal	Clean the electrodes of the machine. (Refer to Fig. 2-9.)
3	High-voltage power supply PCB failure	Replace the high-voltage power supply PCB ASSY.
4	Main PCB failure	Replace the main PCB ASSY.

4.7.5 Error message prompting drum replacement does not disappear

<User Check>

- Reset the drum counter according to the manual.

Step	Cause	Remedy
1	Main PCB failure	Replace the main PCB ASSY.

4.8 Troubleshooting for Fuser Unit Problems

4.8.1 Fuser unit failure

Step	Cause	Remedy
1	Connection failure of the center thermistor harness	Reconnect the center thermistor harness.
2	Connection failure of the side thermistor harness	Reconnect the side thermistor harness.
3	Connection failure of the heater harness	Reconnect the heater harness.
4	Connection failure of the eject sensor harness	Reconnect the eject sensor harness.
5	Eject sensor PCB failure	Replace the eject sensor PCB ASSY.
6	Low-voltage power supply PCB failure	Replace the low-voltage power supply PCB ASSY.
7	Fuser unit failure	Replace the fuser unit.
8	Main PCB failure	Replace the main PCB ASSY.

Note:

- Turn the power switch OFF and then ON again. Leave the machine for 15 minutes. This problem may then be cleared.
- The machine may recover from the error, when the test printing of the maintenance mode for service personnel is started. However, conducting this operation while the heater has not yet cooled may cause the fuser unit to melt. Be careful.

4.9 Troubleshooting for Laser Unit Problems

4.9.1 Laser unit failure

<User Check>

- Turn ON the power switch, then open the front cover and the back cover. Leave the machine for a while to remove condensation.

Step	Cause	Remedy
1	Ground plate contact failure	Retighten the screws to secure the laser unit ground plate.
2	Laser unit attachment failure	Reattach the laser unit.
3	Connection failure of the laser unit flat cable	Reconnect the laser unit flat cable.
4	Laser unit failure	Replace the laser unit.
5	Main PCB failure	Replace the main PCB ASSY.

4.10 Troubleshooting for PCB Problems

4.10.1 Main PCB failure

<User Check>

- Turn the power switch OFF and then ON again.
- Install the latest main firmware.
- Check the print limit ID.
- Check that the print data is not damaged.

Step	Cause	Remedy
1	Main PCB failure	Replace the main PCB ASSY.

4.10.2 Memory full

<User Check>

- Print the accumulated data.
- Reduce the amount or resolution of the data.

Step	Cause	Remedy
1	Main PCB failure	Replace the main PCB ASSY.

4.11 Troubleshooting for Document Feeding Problems

4.11.1 No document is fed

<User Check>

- Set the document properly and check that the display on the LCD changes.
- Check that the number of paper set has not exceeded the upper limit in the paper tray.
- Check that the ADF cover is closed correctly.

Step	Cause	Remedy
1	Document detection actuator coming off	Reattach the document detection actuator.
2	Connection failure of ADF motor harness	Check the connection of the ADF motor harness, and reconnect it if necessary.
3	Boss to push the ADF cover sensor of the ADF cover	Replace the ADF cover ASSY.
4	Document separate roller failure	Replace the document separate roller ASSY.
5	Damaged ADF drive gear	Replace the ADF unit.
6	Main PCB failure	Replace the main PCB ASSY.

4.11.2 Multiple documents are fed

<User Check>

- Check that paper used for the document is not thinner than 64 g/m².

Step	Cause	Remedy
1	Abrasion of ADF separation pad	Replace the ADF unit.

4.11.3 Document jam

■ Paper jam in the ADF cover

<User Check>

- Check that the paper used for the document is not thinner than 64 g/m².
- Check that the paper used for the document is not shorter than 147.3 mm.
- Check that the number of paper set has not exceeded the upper limit in the paper tray.
- Check that the ADF cover is closed correctly.

Step	Cause	Remedy
1	Foreign object inside the area around ADF cover	Remove foreign objects inside the area around the ADF cover.
2	Document pinch roller 1 coming off	Reattach the document pinch roller 1.
3	ADF cover sensor failure	Replace the ADF unit.
4	Main PCB failure	Replace the main PCB ASSY.

■ **Paper jam in the ADF**

<User Check>

- Check that the paper used for the document is not thinner than 64 g/m².
- Check that the paper used for the document is not longer than 900 mm (400 mm when duplex scanning).
- Check that the document guide is adjusted to suit the document size.

Step	Cause	Remedy
1	Foreign object inside the ADF	Remove foreign objects inside the ADF
2	Document scanning position actuator coming off	Reattach the document scanning position actuator.
3	Document pinch roller 2 coming off	Reattach the document pinch roller 2.
4	Connection failure of document scanning position sensor harness	Check the connection of the document scanning position sensor harness, and reconnect it if necessary.
5	Second side document hold coming off	Reattach the second side document hold.
6	First side document hold coming off	Reattach the first side document hold.
7	Fed at an angle and jammed due to abrasion of document separate roller	Replace the document separate roller ASSY.
8	Document scanning position sensor failure	Replace the ADF unit.
9	Main PCB failure	Replace the main PCB ASSY.

■ **Paper jam in the paper eject section of the ADF**

Step	Cause	Remedy
1	Foreign object in the ADF document eject path	Remove foreign objects in the ADF document eject path.
2	Document pinch roller coming off	Reattach the document pinch roller.
3	Abrasion of document eject roller	Replace the ADF unit.
4	Main PCB failure	Replace the main PCB ASSY.

4.11.4 Document becomes wrinkled

<User Check>

- Check that the document guide is adjusted to suit the document size.
- Check that the document is not curled.

Step	Cause	Remedy
1	Abrasion of document separate roller	Replace the document separate roller ASSY.
2	Abrasion of document feed roller	Replace the ADF unit.

4.11.5 Document size is not detected correctly

<User Check>

- Check that the document size is within the standard.

Step	Cause	Remedy
1	Document scanning position actuator caught in some sections of the machine	Reattach the document scanning position actuator.
2	ADF motor failure	Replace the ADF unit.
3	Main PCB failure	Replace the main PCB ASSY.

4.12 Troubleshooting for Image Defects

4.12.1 Defect examples



Fig. 2-18

4.12.2 Troubleshooting according to image defect

■ Light



<User Check>

- Check that the contrast setting is not too light.
- Clean the scanner glass or first side/second side scanner glass strip.
- Clean the document hold.

Step	Cause	Remedy
1	Incorrect white level correction data	Execute "Acquire white level data (function code: 55)".
2	First or second side CIS unit failure	Replace the first or second side CIS unit.
3	Main PCB failure	Replace the main PCB ASSY.

■ Faulty registration



(1) ADF

Step	Cause	Remedy
1	Deviation of the scanning start position	Execute "Fine adjustment of scan start position. (function code: 54)".
2	Document scanning position actuator caught in some sections of the machine	Reattach the document scanning position actuator.

(2) Document scanner unit

Step	Cause	Remedy
1	Deviation of the scanning start position	Execute "Fine adjustment of scan start position. (function code: 54)".
2	First side CIS unit failure	Replace the first side CIS unit.

■ Dark



<User Check>

- Check that the contrast setting is not too dark.
- Clean the document hold.

Step	Cause	Remedy
1	Incorrect white level correction data	Execute "Acquire white level data (function code: 55)".
2	First or second side CIS unit failure	Replace the first or second side CIS unit.
3	Main PCB failure	Replace the main PCB ASSY.

■ **Completely blank**



<User Check>

- Check that the document is not reversed.

Step	Cause	Remedy
1	Incorrect white level correction data	Execute "Acquire white level data (function code: 55)".
2	First or second side CIS flat cable failure	Replace the first or second side CIS flat cable.
3	First or second side CIS unit failure	Replace the first or second side CIS unit.
4	Main PCB failure	Replace the main PCB ASSY.

■ **All black**



<User Check>

- Install all the latest firmwares.

Step	Cause	Remedy
1	Incorrect white level correction data	Execute "Acquire white level data (function code: 55)".
2	First or second side CIS flat cable failure	Replace the first or second side CIS flat cable.
3	First or second side CIS unit failure	Replace the first or second side CIS unit.
4	Main PCB failure	Replace the main PCB ASSY.

■ **Vertical streaks**



<User Check>

- Clean the scanner glass or first side/second side scanner glass strip.
- Clean the document hold.

Step	Cause	Remedy
1	Dirt inside of scanner glass	Clean the inside of the scanner glass.
2	Dirt inside of first side/second side scanner glass strip	Clean the inside of the first side/second side scanner glass strip.
3	First or second side CIS unit failure	Replace the first or second side CIS unit.
4	Scratch on scanner glass	Replace the document scanner unit.
5	Scratch on second side scanner glass strip	Replace the ADF unit.

■ **White streaks**



<User Check>

- Clean the scanner glass or first side/second side scanner glass strip.
- Clean the document hold.

Step	Cause	Remedy
1	Dirt inside of scanner glass	Clean the inside of the scanner glass.
2	Dirt inside of first side/second side scanner glass strip	Clean the inside of the first side/second side scanner glass strip.
3	First or second side CIS unit failure	Replace the first or second side CIS unit.
4	Scratch on scanner glass	Replace the document scanner unit.
5	Scratch on second side scanner glass strip	Replace the ADF unit.

■ **Partially shaded**



<User Check>

- Clean the scanner glass.

Step	Cause	Remedy
1	Dirt inside of scanner glass	Clean the inside of scanner glass.
2	Deformed document sponge	Replace the document scanner unit.

■ **Fully tinged**

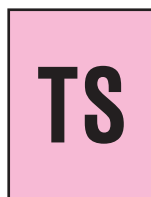

<User Check>

- Clean the scanner glass or first side/second side scanner glass strip.

Step	Cause	Remedy
1	Incorrect white level correction data	Execute "Acquire white level data (function code: 55)".
2	First or second side CIS unit failure	Replace the first or second side CIS unit.
3	Main PCB failure	Replace the main PCB ASSY.

4.13 Troubleshooting for Fax Problems

4.13.1 Fax cannot be sent

<User Check>

- Check that the line cord is inserted into the socket correctly.
- Check that the dial function setting (tone/pulse) is correct.
- Check that the fax document is set in the ADF correctly.
- Check that the handset curled cord is inserted into the socket correctly.
- Check that the handset is placed on the handset holder correctly.
- Check that the number to be dialed is saved correctly in the telephone directory.
- Check that the receiver's machine works normally or the function you want to perform is equipped with the receiver's machine.
- Move the machine to the other place to check whether there is any noise source near the machine.
- Replace the telephone line.

Step	Cause	Remedy
1	Connection failure of modem flat cable	Reconnect the modem flat cable.
2	Connection failure of CIS flat cable	Reconnect the CIS flat cable.
3	Connection failure of panel flat cable	Reconnect the panel flat cable.
4	Connection failure of touch panel flat cable	Reconnect the touch panel flat cable.
5	Connection failure of key PCB flat cable	Reconnect the key PCB flat cable.
6	Connection failure of ADF cover/document detection sensor PCB harness	Reconnect the ADF cover/document detection sensor PCB harness.
7	Document detection actuator coming off	Reattach the document detection actuator.
8	First or second side CIS flat cable failure	Replace the first or second side CIS flat cable.
9	First or second side CIS unit failure	Replace the first or second side CIS unit.
10	ADF drive gear failure	Replace the ADF unit.
11	Document scanner unit failure	Replace the document scanner unit.
12	Panel PCB failure	Replace the panel PCB ASSY.
13	Touch panel failure	Replace the touch panel ASSY.
14	Key PCB failure	Replace the panel unit.
15	Modem PCB failure	Replace the modem PCB ASSY.
16	Main PCB failure	Replace the main PCB ASSY.

4.13.2 Fax cannot be received

<User Check>

- Check that the line cord is inserted into the socket correctly.
- Check that the receiving mode setting is correct.
- Check that the handset is placed on the handset holder correctly.
- Check that the receiver's machine works normally or the function you want to perform is equipped with the receiver's machine.
- Move the machine to the other place to check whether there is any noise source near the machine.
- Replace the telephone line.

Step	Cause	Remedy
1	Connection failure of modem flat cable	Check the connection of the modem flat cable, and reconnect it if necessary.
2	Modem PCB failure	Replace the modem PCB ASSY.
3	Main PCB failure	Replace the main PCB ASSY.

4.13.3 Communication error occurs

<User Check>

- Check whether there is any noise source near the machine.
- Replace the telephone line.

Step	Cause	Remedy
1	Connection failure of modem flat cable	Check the connection of the modem flat cable, and reconnect it if necessary.
2	Modem PCB failure	Replace the modem PCB ASSY.
3	Main PCB failure	Replace the main PCB ASSY.

4.14 Troubleshooting for Other Problems

4.14.1 Cannot print

<User Check>

- Turn the power switch OFF and then ON again.
- Check that the USB cable is connected to the host correctly.
- Check that the LAN cable is connected to the host correctly.
- Replace the USB cable.
- Replace the LAN cable.
- Check that the maximum printable page number has not been exceeded.
- Check that the PC Print is not forbidden.
- Check the print limit ID.
- Check the network connection.
- Check the relevant section in the Network Setting Guide.
- Check that the print data is not damaged.
- Install the latest main firmware.
- Match the document size with the one specified in the driver.

Step	Cause	Remedy
1	Connection failure of the wireless LAN connector	Reconnect the wireless LAN connector.
2	Wireless LAN PCB failure	Replace the wireless LAN PCB.
3	Main PCB failure	Replace the main PCB ASSY.

4.14.2 Cannot update firmware

<User Check>

- Make sure that there is no other function running.
- Turn the power switch OFF and then ON again.

Step	Cause	Remedy
1	Firmware version does not match	Reinstall the latest sub firmware and main firmware in this order.
2	Main PCB failure	Replace the main PCB ASSY.

4.14.3 USB direct interface errors

<User Check>

- Replace the USB flash memory.
- Check that the extension of data in the USB flash memory is correct.
- Check that an USB device not within the specifications is not connected.
- Check that multiple USB devices are not connected.

Step	Cause	Remedy
1	USB host harness failure	Replace the USB host harness.
2	USB host PCB failure	Replace the USB host PCB ASSY.
3	Main PCB failure	Replace the main PCB ASSY.

4.14.4 "Paper Low" message does not disappear

<User Check>

- Refill the paper in the appropriate paper tray.
- Turn the power switch OFF and then ON again.

Step	Cause	Remedy
1	Damaged plate-up plate in the paper tray	Replace the paper tray.
2	Paper feed motor failure	Replace the paper feed motor.
3	Damaged plate push-up mechanism in the machine	Replace the main frame L ASSY.
4	Main PCB failure	Replace the main PCB ASSY.

CHAPTER 3 DISASSEMBLY/REASSEMBLY

1. SAFETY PRECAUTIONS

To avoid creating secondary problems by mishandling, follow the warnings and precautions below during maintenance work.

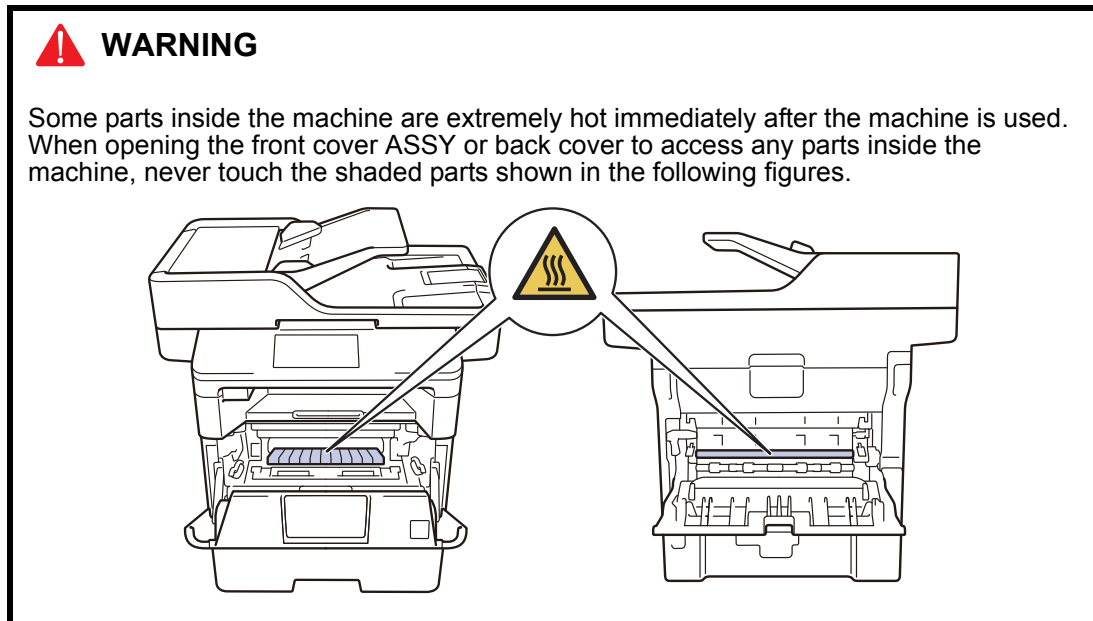

- Be careful not to lose screws, washers, or other parts removed.
- Be sure to apply grease to applicable positions specified in this chapter.
- When using soldering irons or other heat-generating tools, take care not to accidentally damage parts such as wires, PCBs and covers.
- Static electricity charged in your body may damage electronic parts. When transporting PCBs, be sure to wrap them in conductive sheets.
- When replacing the PCB and all the other related parts, put on a grounding wrist band and perform the job on a static mat. Also take care not to touch the conductor sections on the flat cables or on the wire harness.
- After disconnecting flat cables, check that each cable is not damaged at its end or shortcircuited.
- When connecting flat cables, do not insert them at an angle. After insertion, check that the cables are not at an angle.
- When connecting or disconnecting harnesses, hold the connector body, not the cables. If the connector is locked, release it first.
- After a repair, check not only the repaired portion but also harness treatment. Also check that other related portions are functioning properly.
- Forcefully closing the front cover without mounting the toner cartridge and the drum unit can damage the machine.
- The insulation sheet should not be damaged.
- When replacing the PCB, clear the component side and solder side from foreign objects.

2. PACKING

Machine

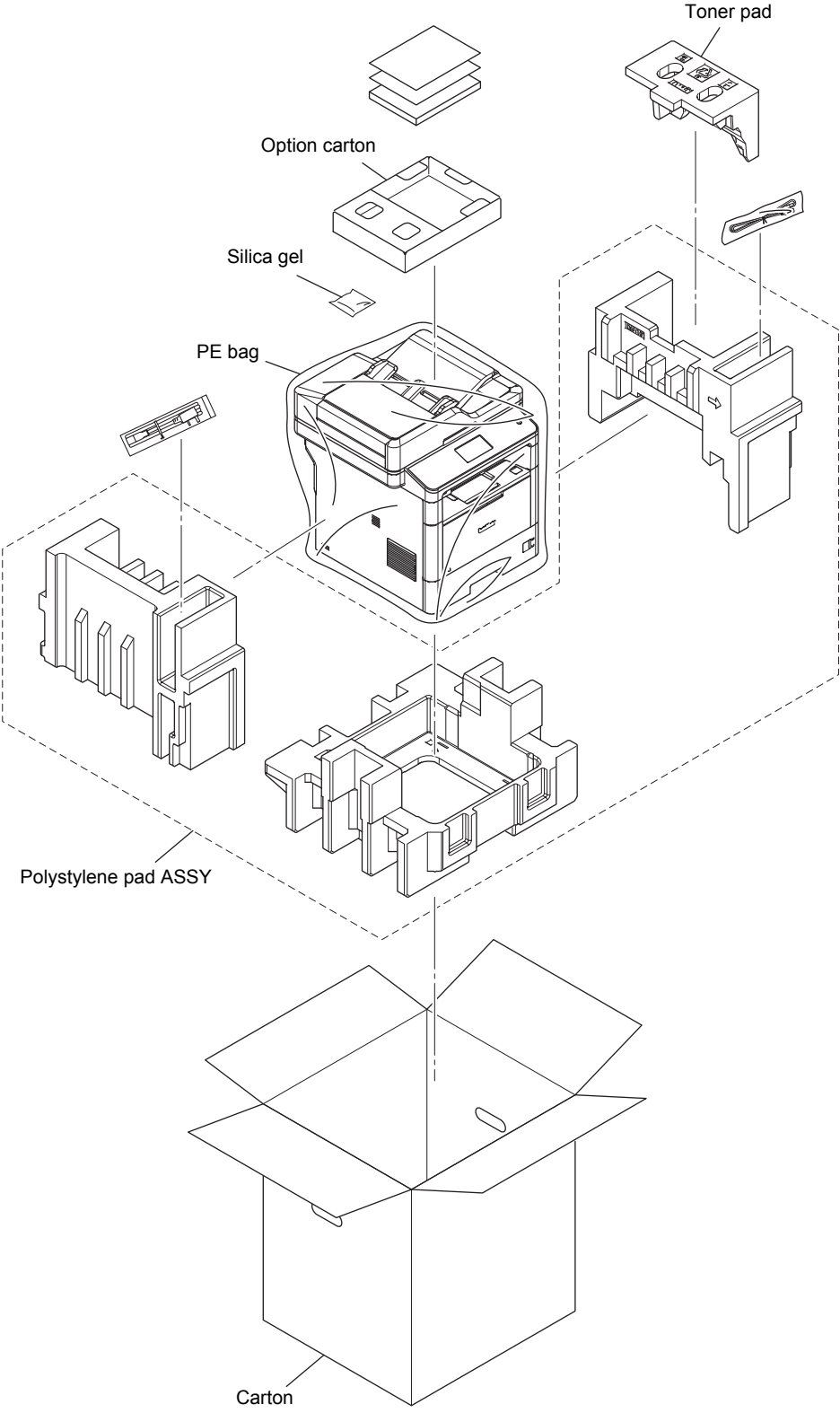

Fig. 3-1

3. SCREW CATALOGUE

Taptite bind B

Taptite bind B M3x10	
Taptite bind B M4x12	
Taptite bind B M4x30	

Taptite cup S

Taptite cup S M3x6 SR	
Taptite cup S M3x8 SR	

Screw cup

Screw cup M3x8	
-------------------	--

Screw pan (S/P washer)

Screw pan (S/P washer) M3x12DB	
Screw pan (S/P washer) M3.5x6	

Taptite pan B

Taptite pan B M3x8	
Taptite pan B M4x14	

Taptite cup B

Taptite cup B M3x10	
------------------------	--

Screw pan

Screw pan M4x8	
-------------------	--

Taptite flat B

Taptite flat B M3x10	
-------------------------	--

Fig. 3-2

4. SCREW TORQUE LIST

Location of screw	Screw type	Q'ty	Tightening torque N·m (kgf·cm)
Fuser unit line cover R	Taptite bind B M4x12	1	0.8±0.1 (8±1)
Fuser unit line cover L	Taptite pan B M4x14	1	0.8±0.1 (8±1)
Fuser unit	Taptite pan B M4x14	1	0.8±0.1 (8±1)
Side cover L	Taptite bind B M4x12	2	0.8±0.1 (8±1)
Side cover R	Taptite bind B M4x12	2	0.8±0.1 (8±1)
Main shield plate	Screw cup M3x8 (Black)	3	0.45±0.05 (4.5±0.5)
ADF FG harness			
Modem FG harness L			
FB FG harness			
Panel FG harness	Taptite cup S M3x8 SR	1	0.6±0.1 (6±1)
ADF/document scanner unit	Taptite bind B M4x12	6	0.8±0.1 (8±1)
ADF unit (Hinge L ASSY)	Taptite bind B M4x12 (Black)	1	0.8±0.1 (8±1)
Hinge L ASSY	Taptite bind B M4x12	3	0.8±0.1 (8±1)
Hinge R support	Taptite cup B M3x10	1	0.5±0.1 (5±1)
Hinge arm R	Taptite cup B M3x10	3	0.5±0.1 (5±1)
ADF front cover	Taptite cup B M3x10	2	0.5±0.1 (5±1)
ADF separation holder ASSY	Taptite cup B M3x10	1	0.5±0.1 (5±1)
Upper document chute	Taptite cup B M3x10	6	0.5±0.1 (5±1)
Panel unit	Taptite cup B M3x10	4	0.5±0.1 (5±1)
LCD presser	Taptite cup B M3x10	3	0.5±0.1 (5±1)
Shield plate cover	Taptite cup B M3x10	4	0.5±0.1 (5±1)
USB host PCB ASSY	Taptite bind B M4x12	2	0.8±0.1 (8±1)
Scanner top cover	Taptite bind B M4x12	8	0.8±0.1 (8±1)
Modem FG harness R (Frame R side)	Taptite cup S M3x6 SR	1	0.6±0.1 (6±1)
Joint cover ASSY	Taptite bind B M4x12	6	0.8±0.1 (8±1)
Modem FG harness L (Modem side)	Screw pan (S/P washer) M3.5x6	1	0.6±0.1 (6±1)
Modem FG harness R (Modem side)	Screw pan (S/P washer) M3.5x6	1	0.6±0.1 (6±1)
Modem shield plate	Taptite bind B M4x12	2	0.8±0.1 (8±1)
Modem shield cover	Screw pan (S/P washer) M3.5x6	1	0.6±0.1 (6±1)
Modem PCB ASSY	Taptite cup S M3x6 SR	2	0.5±0.1 (5±1)
Veil cover lower	Screw cup M3x8 (Black)	1	0.45±0.05 (4.5±0.5)
Main PCB ASSY	Screw cup M3x8 (Black)	4	0.45±0.05 (4.5±0.5)
Top bar (T1: Models with 520-sheet)	Taptite bind B M4x12	2	0.8±0.1 (8±1)
Laser unit	Taptite cup S M3x8 SR	4	0.8±0.05 (8±0.5)

Location of screw	Screw type	Q'ty	Tightening torque N·m (kgf·cm)
Scanner ground plate	Taptite cup S M3x8 SR (Fastening side of scanner plate)	1	0.8±0.1 (8±1)
	Screw cup M3x8 (Black) (LV shield plate cover side)	1	0.45±0.05 (4.5±0.5)
LV shield plate cover	Screw cup M3x8 (Black)	3	0.45±0.05 (4.5±0.5)
	Taptite bind B M4x12	1	0.8±0.1 (8±1)
	Screw pan M4x8	1	0.5±0.1 (5±1)
Ground harness	Screw pan M4x8	1	0.5±0.1 (5±1)
Inlet	Taptite flat B M3x10	1	0.5±0.1 (5±1)
Low-voltage power supply PCB ASSY	Screw cup M3x8 (Black)	1	0.45±0.05 (4.5±0.5)
	Taptite bind B M4x12	2	0.8±0.1 (8±1)
Under bar ground plate R (T1: Models with 520-sheet)	Taptite cup S M3x8 SR (Fastening side of LV shield plate)	1	0.6±0.1 (6±1)
Under bar front (T1: Models with 250-sheet)	Taptite cup S M3x8 SR (Fastening side of LV shield plate)	1	0.6±0.1 (6±1)
LV shield plate	Taptite bind B M4x12	1	0.8±0.1 (8±1)
Hold cover 1	Taptite bind B M4x12	1	0.8±0.1 (8±1)
Pinch ground spring	Taptite pan B M3x8	1	0.5±0.1 (5±1)
Hold cover 2	Taptite bind B M4x12	2	0.8±0.1 (8±1)
Under bar front (T1: Models with 520-sheet)	Taptite bind B M4x12	2	0.8±0.1 (8±1)
Under bar ground plate L			
Under bar ground plate R			
Under bar cover			
Under bar rear	Taptite bind B M4x12	2	0.8±0.1 (8±1)
Under bar center	Taptite bind B M4x12	2	0.8±0.1 (8±1)
Top bar rear	Taptite bind B M4x12	2	0.8±0.1 (8±1)
Under bar ground plate L (T1: Models with 520-sheet)	Taptite cup S M3x8 SR (Fastening side of drive sub ASSY)	1	0.6±0.1 (6±1)
Under bar front (T1: Models with 250-sheet)	Taptite cup S M3x8 SR (Fastening side of drive sub ASSY)	1	0.6±0.1 (6±1)
	Taptite bind B M4x12	2	0.8±0.1 (8±1)
Main frame L ASSY	Taptite cup S M3x8 SR	4	0.8±0.1 (8±1)
	Taptite bind B M4x12	4	0.8±0.1 (8±1)
Drive sub ASSY	Taptite bind B M4x12	8	0.8±0.1 (8±1)
Paper feed motor plate	Taptite cup S M3x8 SR	4	0.8±0.1 (8±1)
Paper feed motor	Screw bind M3x4	3	0.65±0.05 (6.5±0.5)
MP solenoid	Taptite bind B M3x10	1	0.5±0.1 (5±1)
Main PCB shield calking ASSY	Taptite bind B M4x12	3	0.8±0.1 (8±1)
	Taptite cup S M3x8 SR	2	0.6±0.1 (6±1)

Location of screw	Screw type	Q'ty	Tightening torque N·m (kgf·cm)
Eject motor plate	Taptite bind B M3x10	2	0.5±0.1 (5±1)
Eject motor	Screw bind M3x4	1	0.65±0.05 (6.5±0.5)
Bottom frame L (T1: Models with 520-sheet)	Taptite bind B M4x30	3	0.8±0.1 (8±1)
Base plate	Screw pan (S/P washer) M3x12DB	2	0.6±0.1 (6±1)
	Taptite bind B M4x12	4	0.8±0.1 (8±1)
High-voltage power supply PCB ASSY	Taptite bind B M4x12	2	0.8±0.1 (8±1)
T1 paper feed actuator holder ASSY	Taptite bind B M3x10	1	0.5±0.1 (5±1)
Main frame R	Taptite bind B M4x12	5	0.8±0.1 (8±1)
MP feed frame	Taptite bind B M3x10	2	0.5±0.1 (5±1)
MP paper empty sensor PCB ASSY	Taptite bind B M3x10	1	0.5±0.1 (5±1)
Paper empty sensor PCB ASSY	Taptite bind B M3x10	1	0.5±0.1 (5±1)
LT side cover L	Taptite bind B M4x12	2	0.8±0.1 (8±1)
LT side cover R	Taptite bind B M4x12	2	0.8±0.1 (8±1)
LT front cover ASSY	Taptite cup S M3x8 SR	1	0.8±0.1 (8±1)
Under bar front (Models with 520-sheet)	Taptite bind B M4x12	2	0.8±0.1 (8±1)
Under bar ground plate L (520)	Taptite cup S M3x8 SR	1	0.8±0.1 (8±1)
Under bar front (Models with 250-sheet)	Taptite bind B M4x12	2	0.8±0.1 (8±1)
	Taptite cup S M3x8 SR (3a)	1	0.8±0.1 (8±1)
	Taptite cup S M3x8 SR (3b)	1	0.6±0.1 (6±1)
Under bar	Taptite bind B M4x12	2	0.8±0.1 (8±1)
Center FG plate L	Taptite cup S M3x8 SR (5a)	1	0.8±0.1 (8±1)
	Taptite cup S M3x8 SR (5b)	1	0.6±0.1 (6±1)
Under bar ground plate L (250)	Taptite cup S M3x8 SR	2	0.8±0.1 (8±1)
LT frame L unit	Taptite bind B M4x12	4	0.8±0.1 (8±1)
	Taptite cup S M3x8 SR (7a)	4	0.8±0.1 (8±1)
	Taptite cup S M3x8 SR (7b)	2	0.6±0.1 (6±1)
LT drive ASSY	Taptite bind B M4x12	3	0.8±0.1 (8±1)
Center FG plate R	Taptite cup S M3x8 SR (1a)	1	0.8±0.1 (8±1)
	Taptite cup S M3x8 SR (1b)	1	0.6±0.1 (6±1)
LT paper feed frame	Taptite cup S M3x8 SR	4	0.6±0.1 (6±1)
		Paper feed frame FG plate R	1
LT front beam	Taptite bind B M4x12	2	0.8±0.1 (8±1)
LT paper feed actuator holder ASSY	Taptite bind B M3x10	1	0.5±0.1 (5±1)
LT paper empty sensor PCB ASSY	Taptite bind B M3x10	1	0.5±0.1 (5±1)

5. LUBRICATION

Lubricating oil type (Maker name)	Lubrication point		Quantity of lubrication
FLOIL BG-10KS (Kanto Kasei)	Fuser drive gear 39	10 places	1.5 - 2.0 mm dia. ball
	Develop clutch 51R	1 place	
	Develop joint gear 37	4 places	

■ Fuser drive gear 39

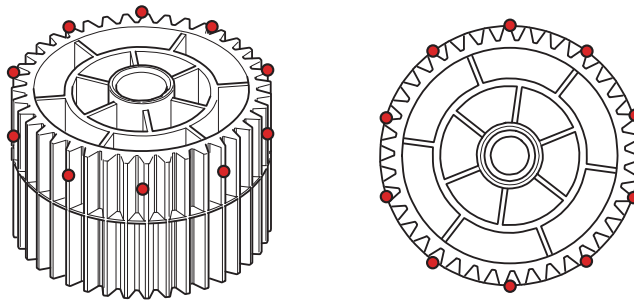

Fig. 3-3

■ Develop clutch 51R

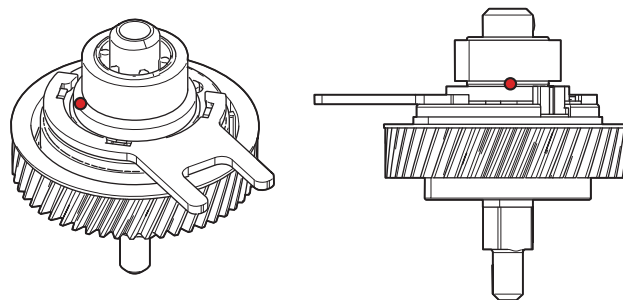

Fig. 3-4

■ Develop joint gear 37

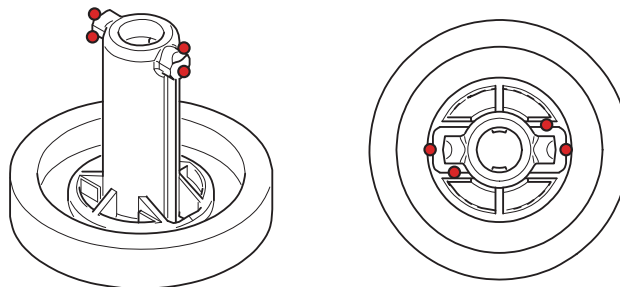

Fig. 3-5

Lubricating oil type (Maker name)	Lubrication point		Quantity of lubrication
HANARL BDX-313A (Kanto Kasei)	MP damper spring	Apply to the internal diameter.	Apply with brush more than once.
	Idle gear 50 Z18M10		

■ **MP damper spring**

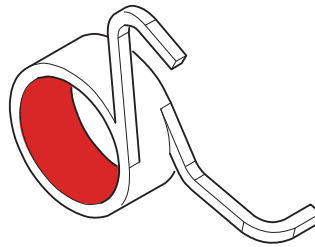

Fig. 3-6

■ **Idle gear 50 Z18M10 (Models with 520-sheet only)**

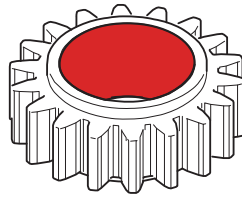

Fig. 3-7

6. OVERVIEW OF GEARS

<Layout view>

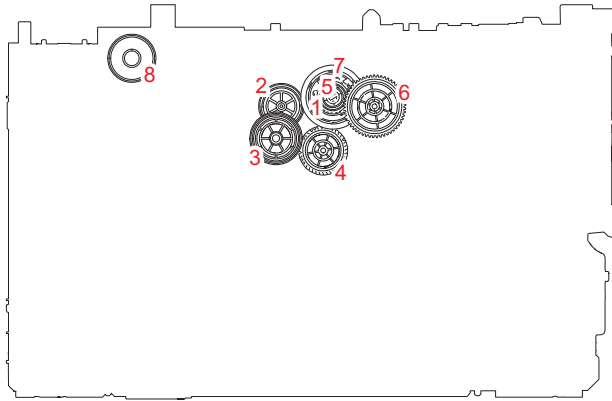

Fig. 3-8

<Development view>

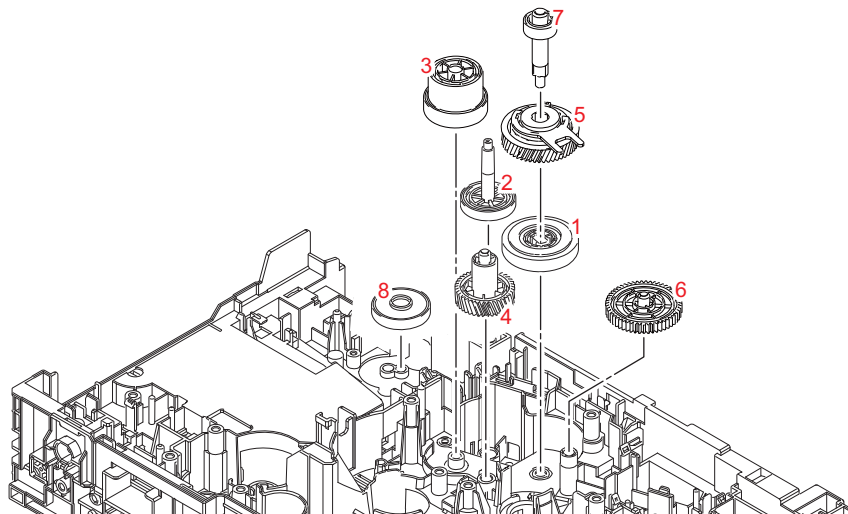

Fig. 3-9

Note:

- When handling gears, make sure that frame L faces up. Otherwise all gears come off.

<Name of gears>

1	LY4409	Develop one way clutch 53	5	LY4408	Develop clutch 51R
2	D001D0	Gear 38 DEV	6	LY4405	Develop idle gear 53
3	D001D2	Sun gear 50R42R18 DEV	7	LY4407	Develop shaft gear 22
4	LY4406	DEV high idle gear 39L	8	D000XL	Eject gear

* These parts are subject to change without notice.

<Layout view>

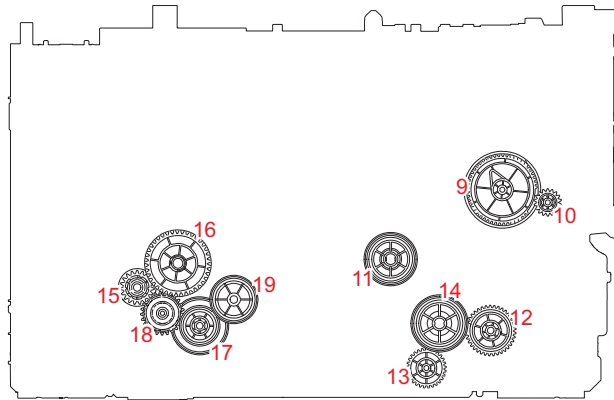

Fig. 3-10

<Development view>

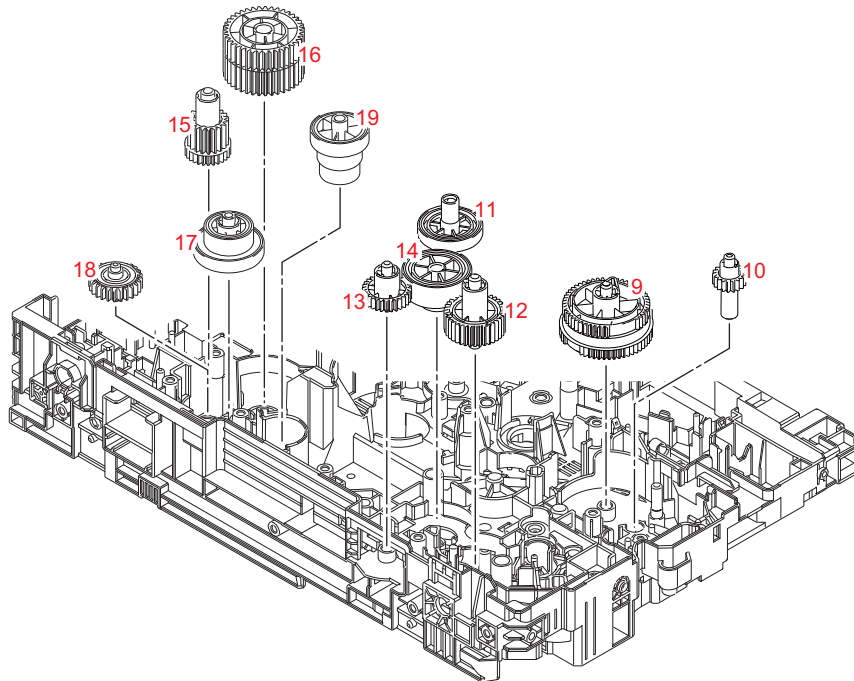

Fig. 3-11

Note:

- When handling gears, make sure that frame L faces up. Otherwise all gears come off.

<Name of gears>

9	LY4394	MP sector gear 53/57	15	LY4451	DX gear 27/19
10	LY4336	MP drive gear 18	16	LY4450	Fuser drive gear 39
11	D004PV	Gear 39/17 PP	17	D0004F	Gear 23/40R fuser
12	LY4403	T1 idle gear 37	18	LY4449	Fuser pendulum gear 25
13	LY4398	LT drive gear 29	19	D0004S	Gear 22L/33L fuser
14	D0041S	T1 gear 19 42			

* These parts are subject to change without notice.

7. HARNESS ROUTING

1 ADF unit - Main PCB ASSY

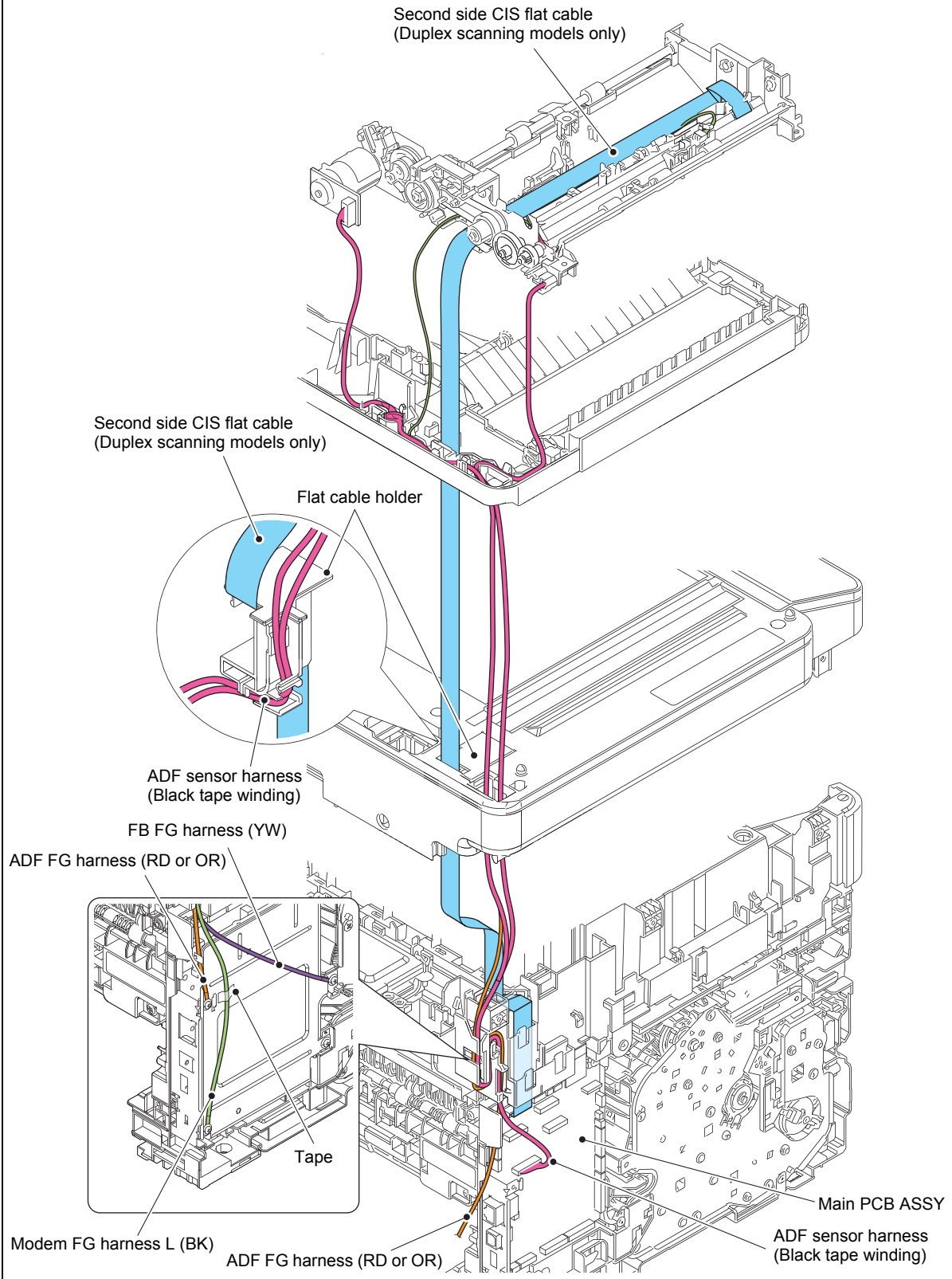

Harness colors are subject to change for some reason.

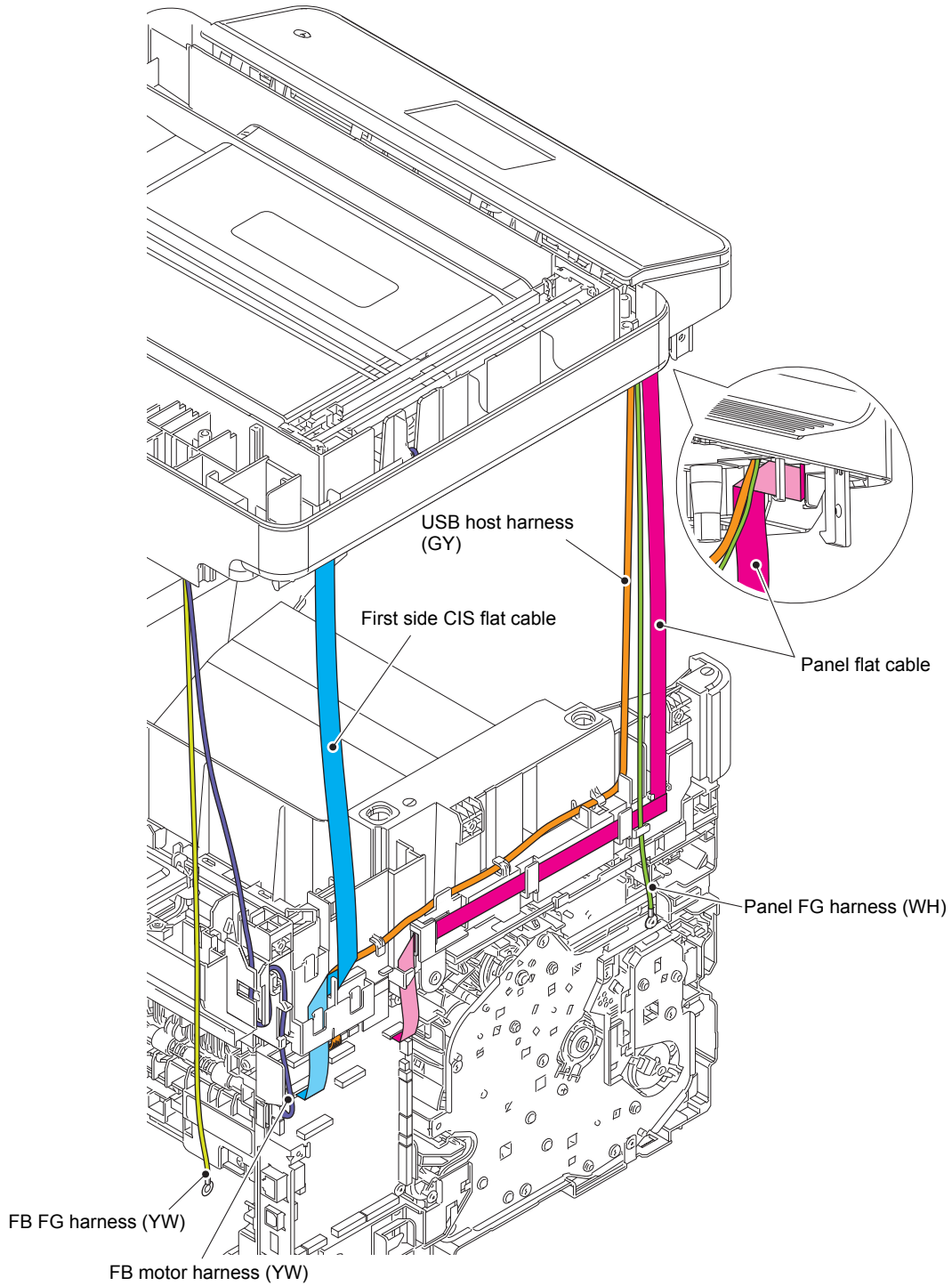

Harness colors are subject to change for some reason.

3

Left side of the machine

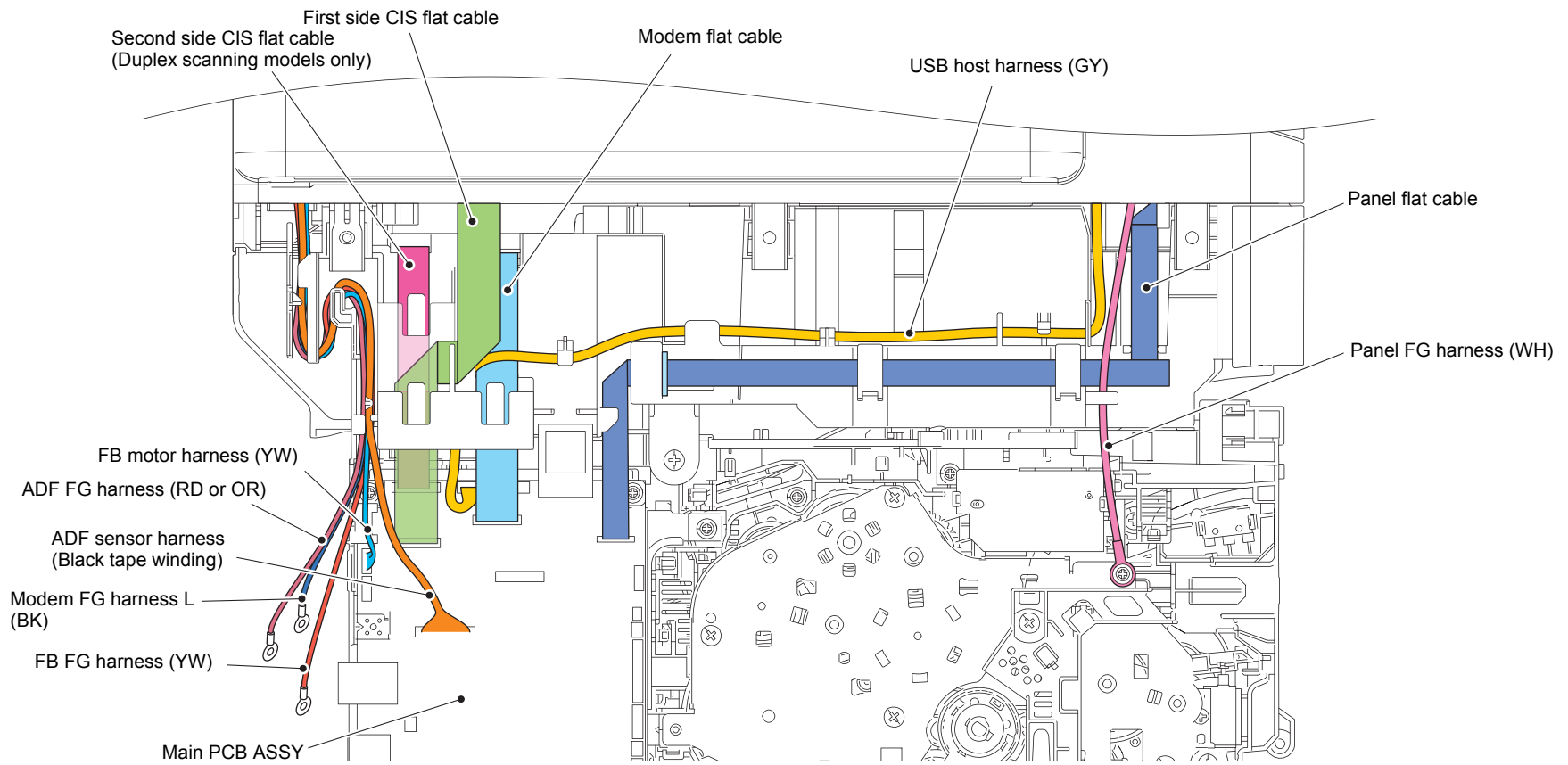

Harness colors are subject to change for some reason.

4 ADF unit

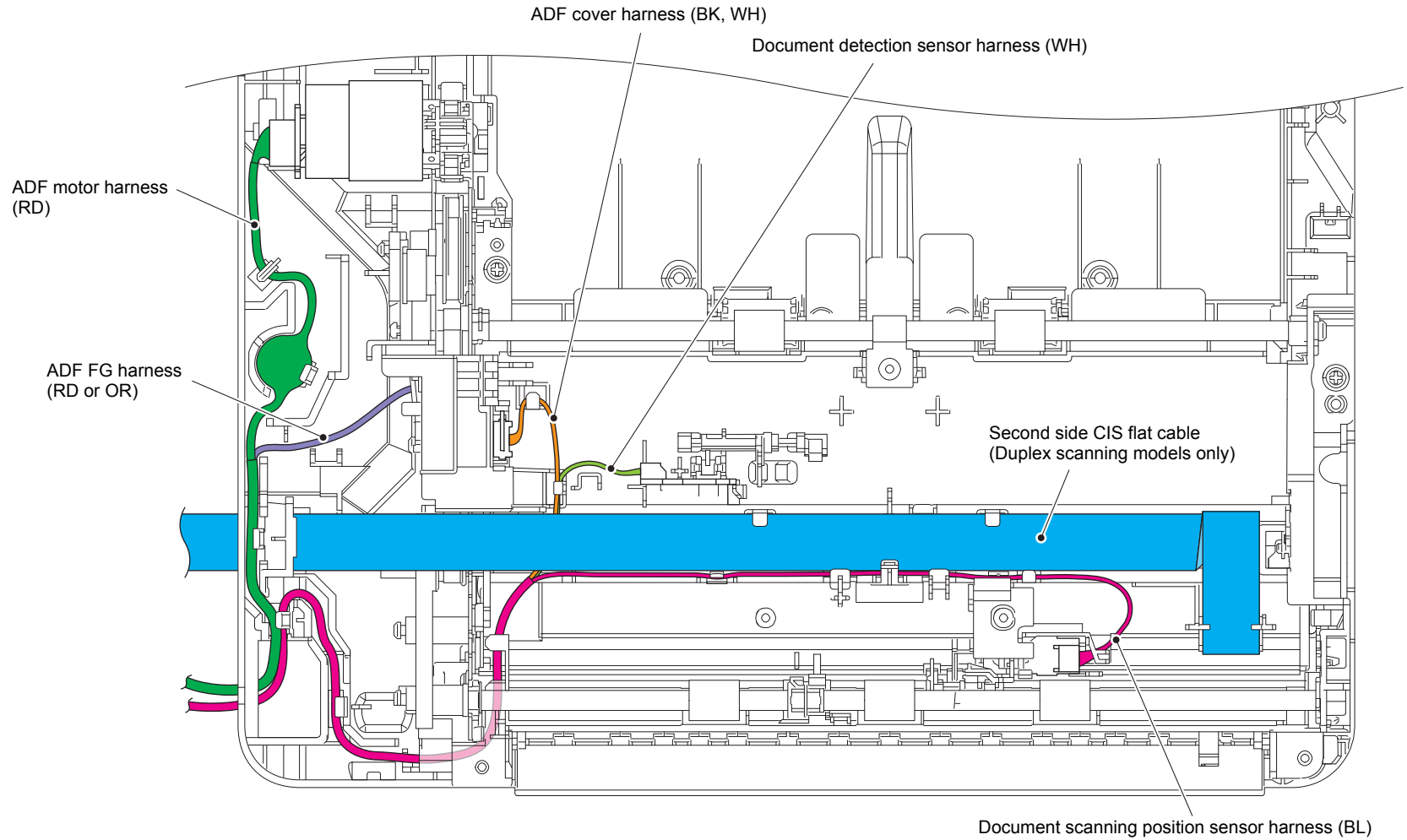

Harness colors are subject to change for some reason.

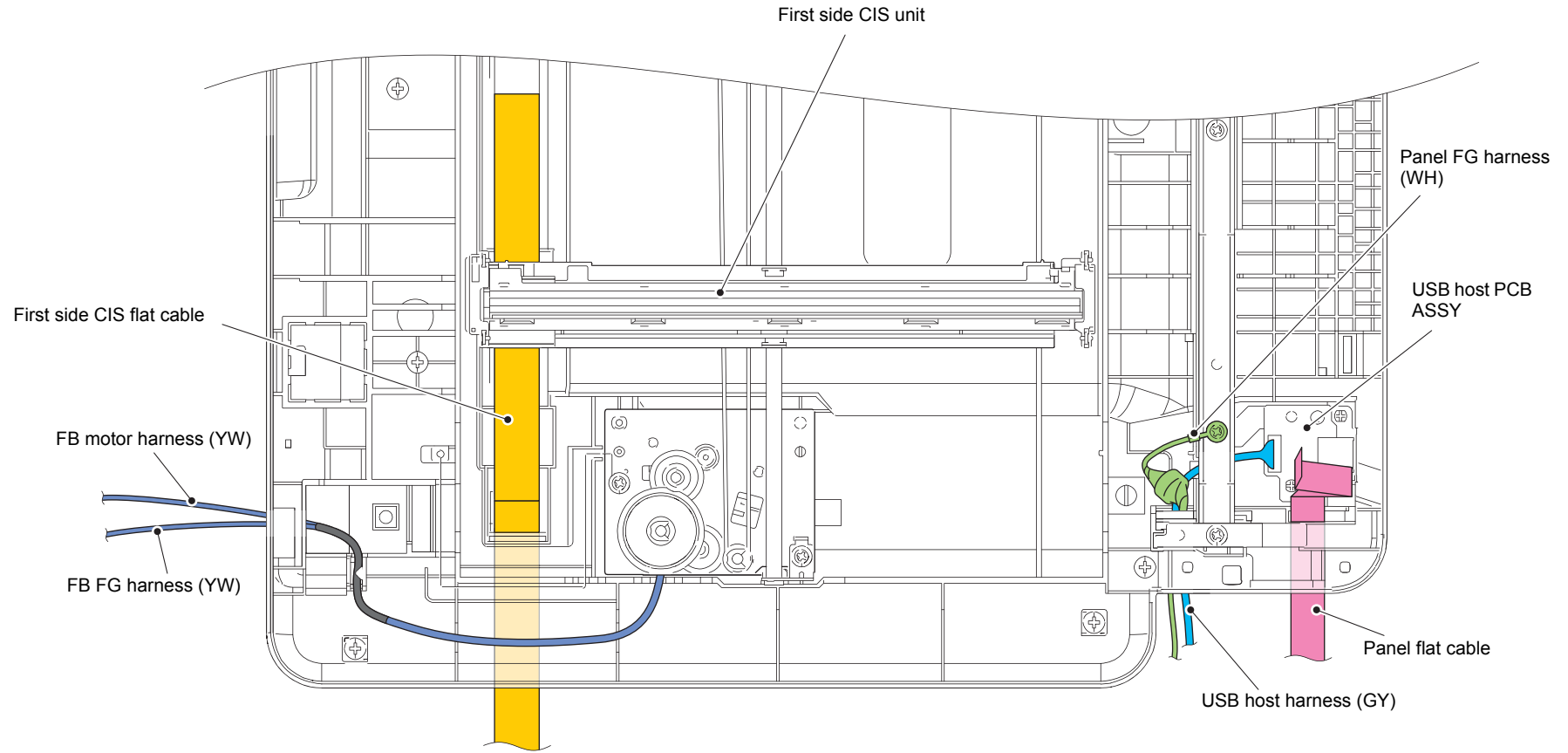

Harness colors are subject to change for some reason.

6

Panel unit (4.85 inch model)

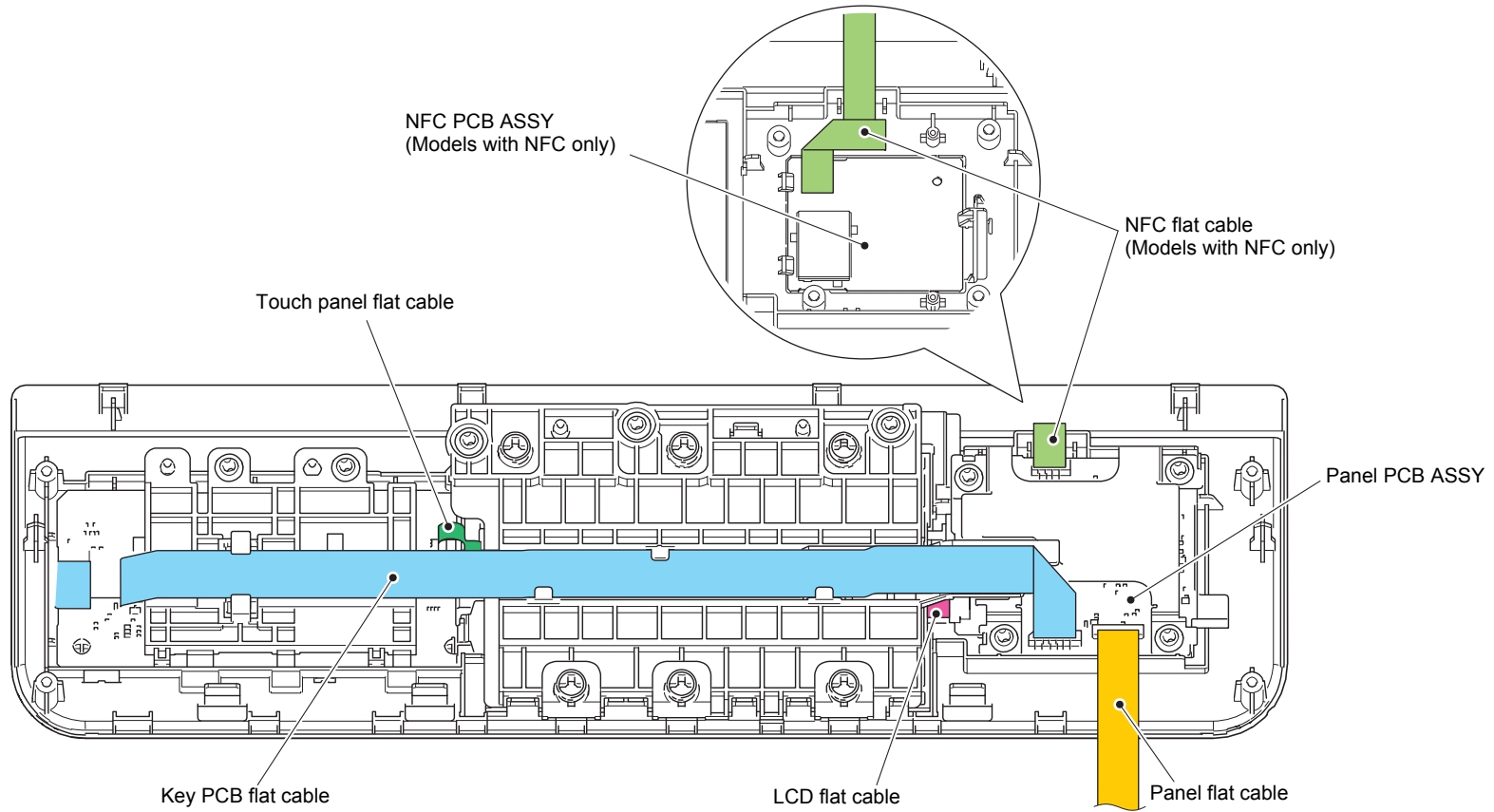

Harness colors are subject to change for some reason.

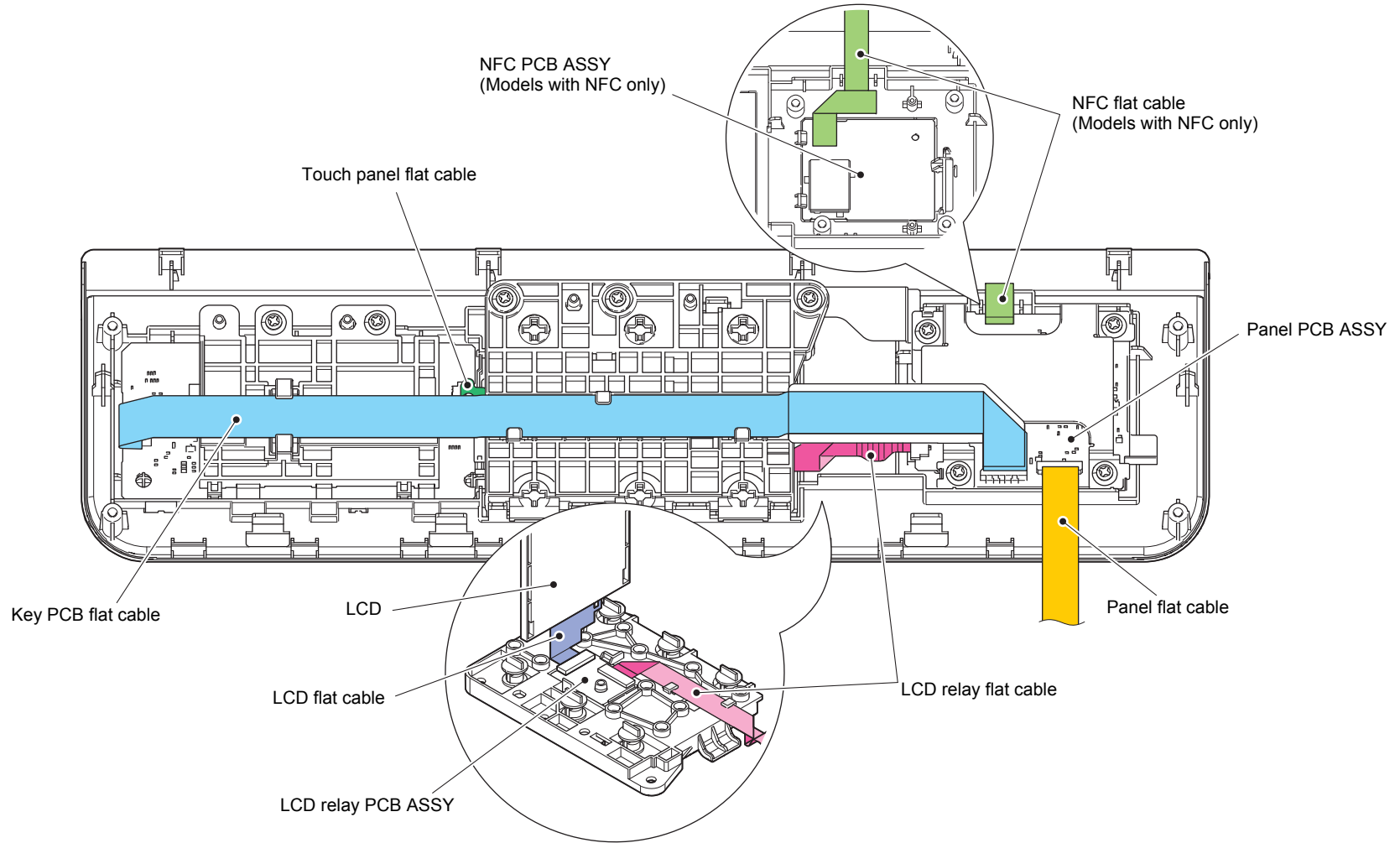

Harness colors are subject to change for some reason.

8

Speaker unit, Modem (Main PCB side)

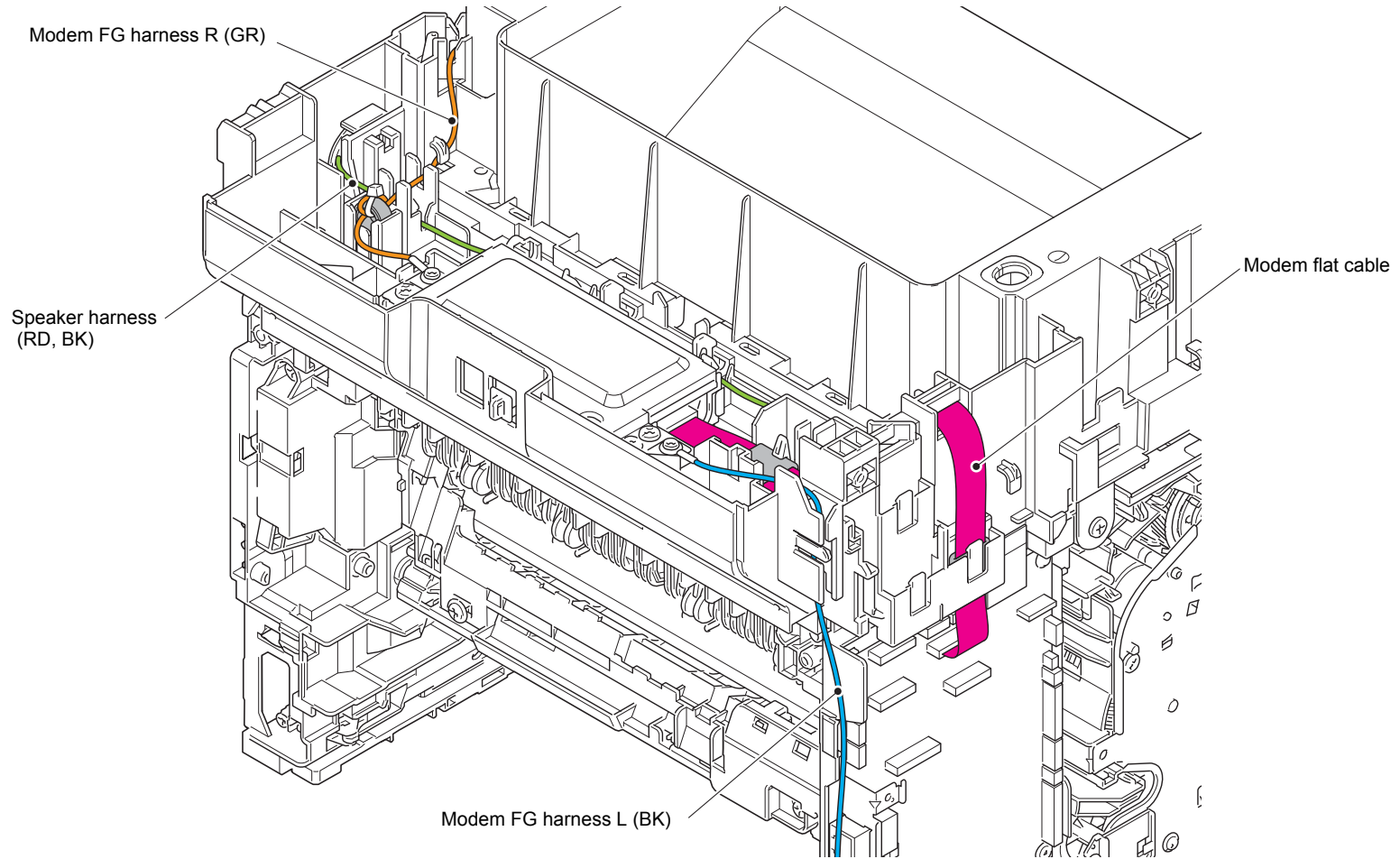

Harness colors are subject to change for some reason.

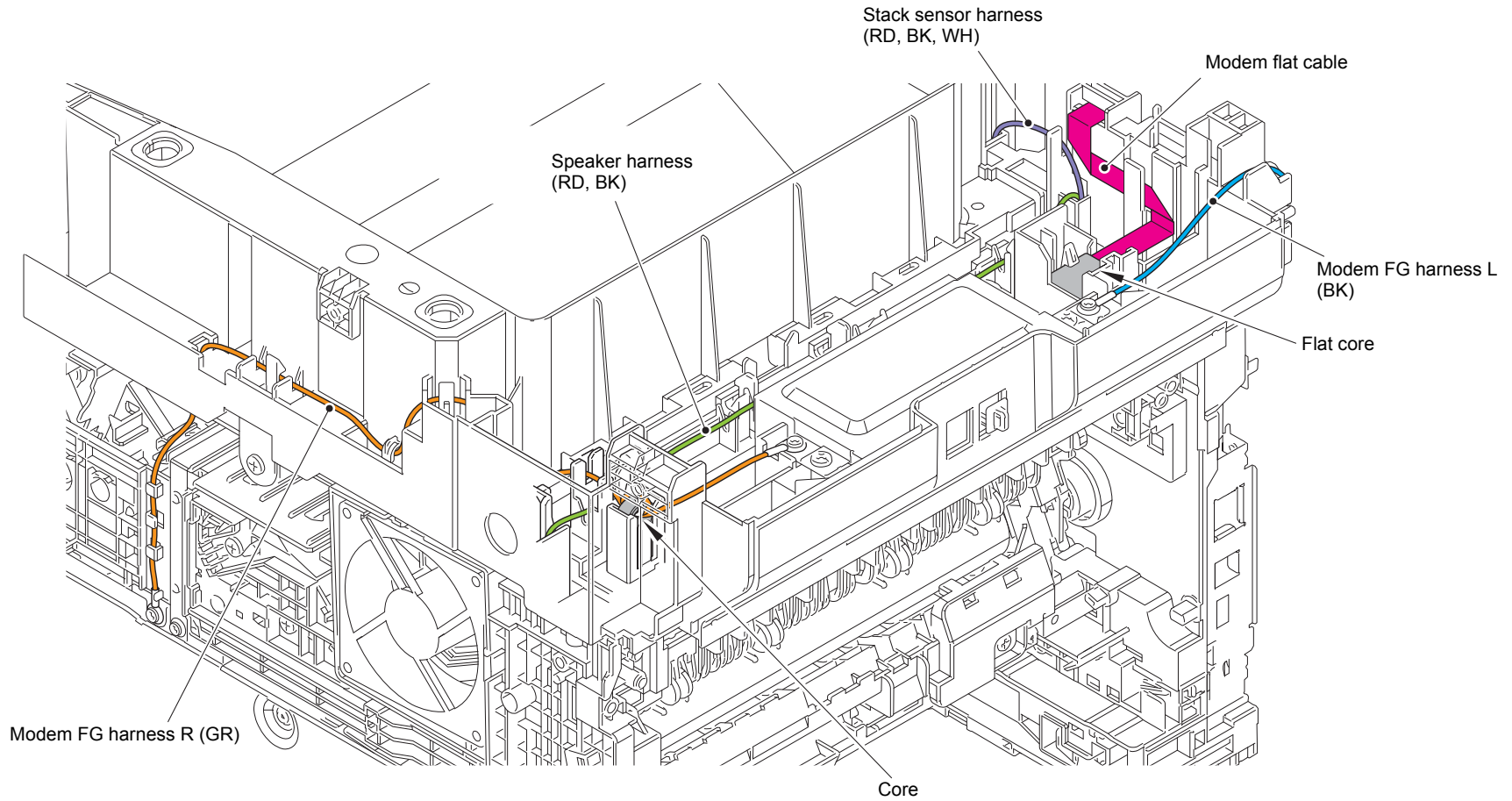

Harness colors are subject to change for some reason.

10 Left side of the machine

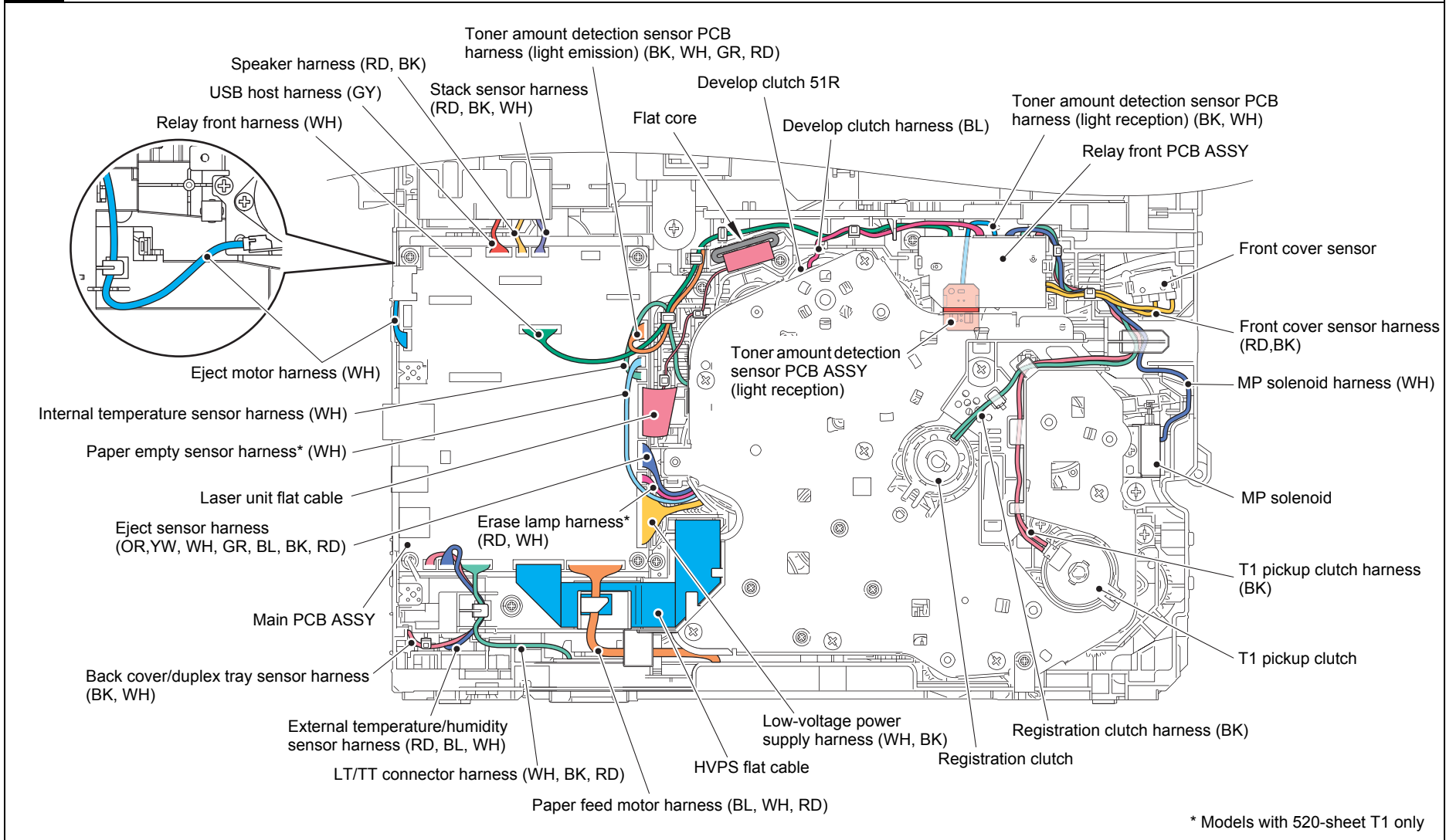

Harness colors are subject to change for some reason.

11 Rear side of the machine

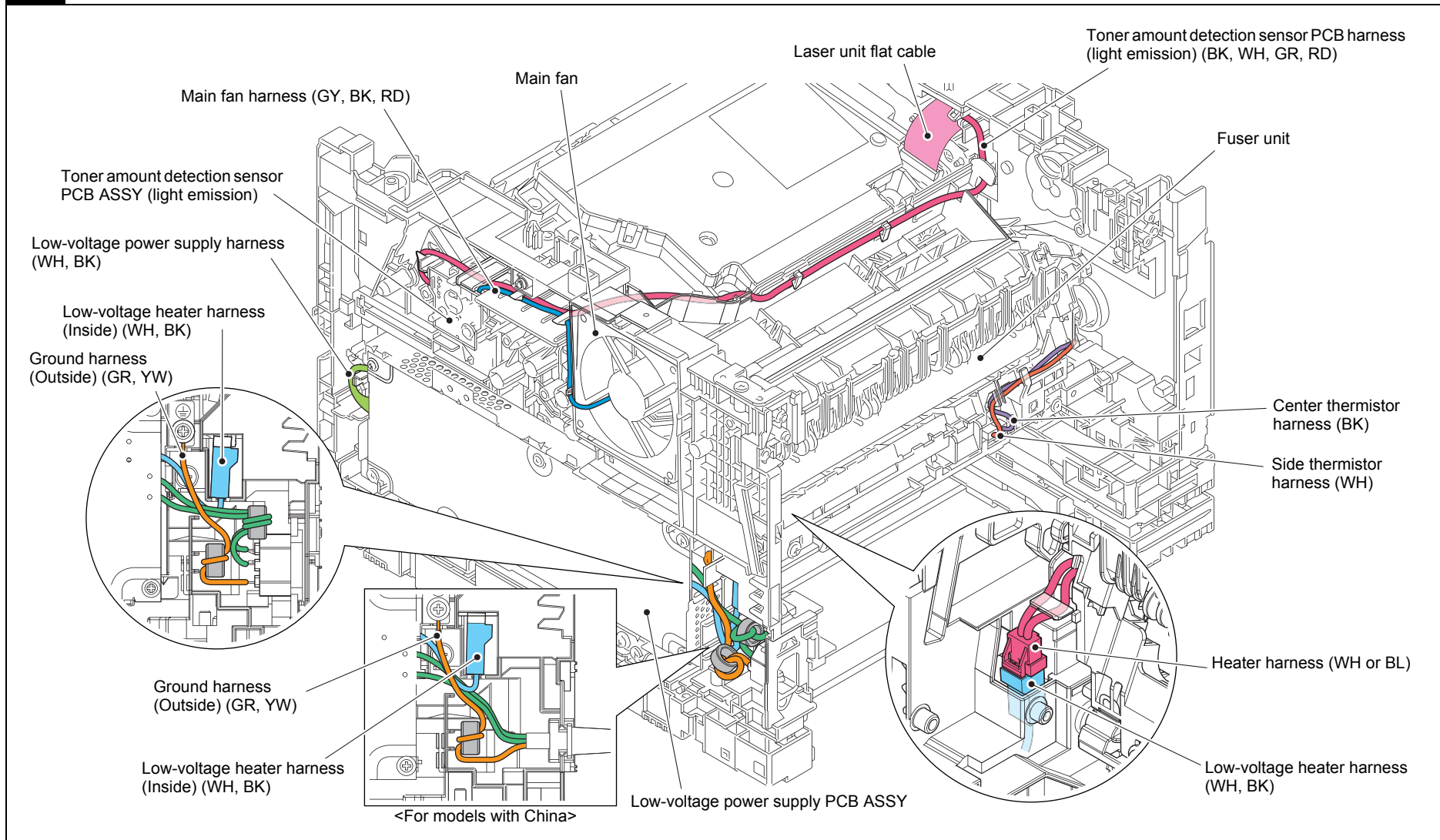

Harness colors are subject to change for some reason.

12 Bottom side of the machine

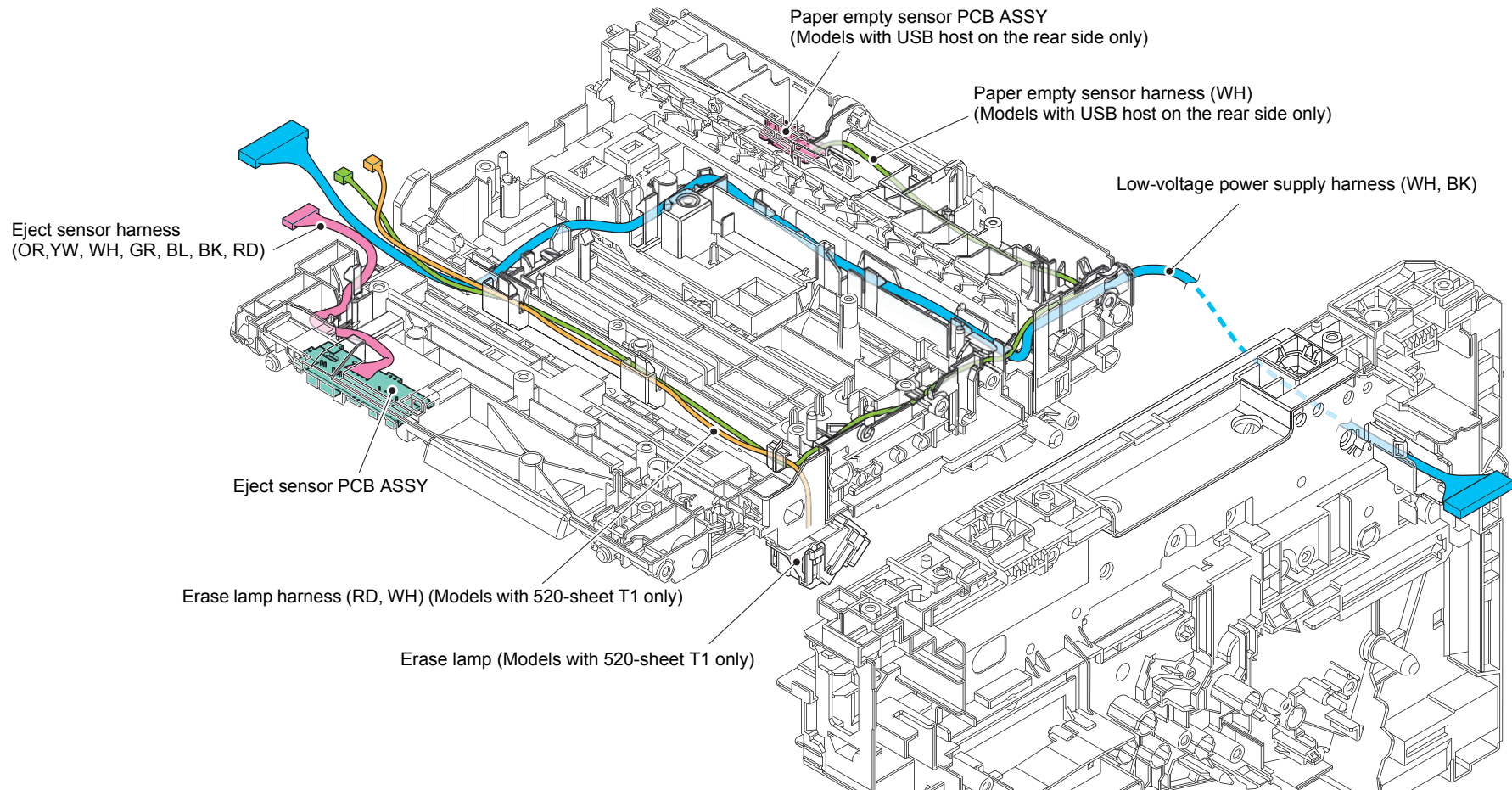

Harness colors are subject to change for some reason.

13

Bottom side of the machine (High-voltage power supply PCB ASSY)

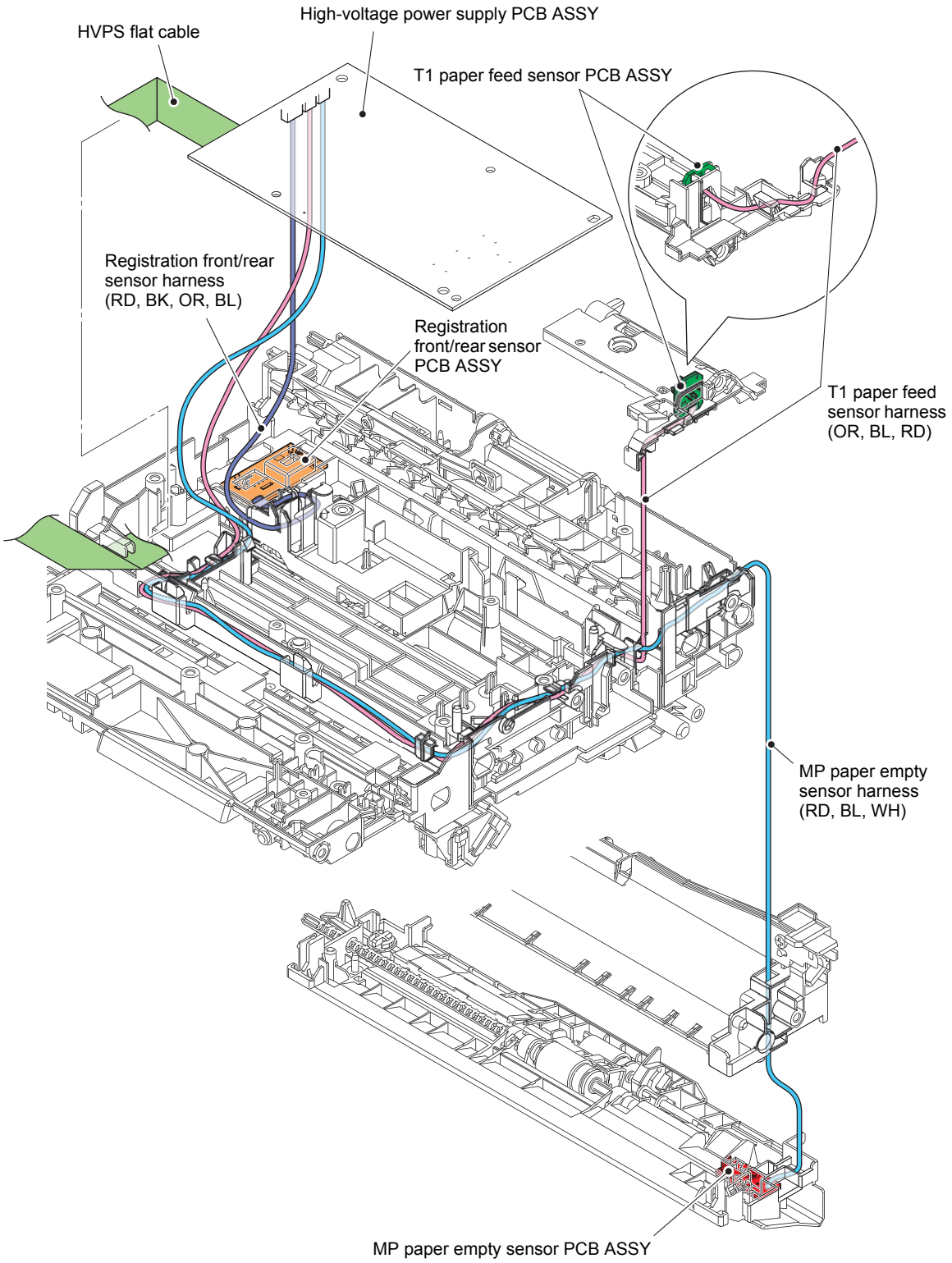

Harness colors are subject to change for some reason.

8. DISASSEMBLY FLOW CHART

8.1 Machine

Disassembly / Reassembly (second)

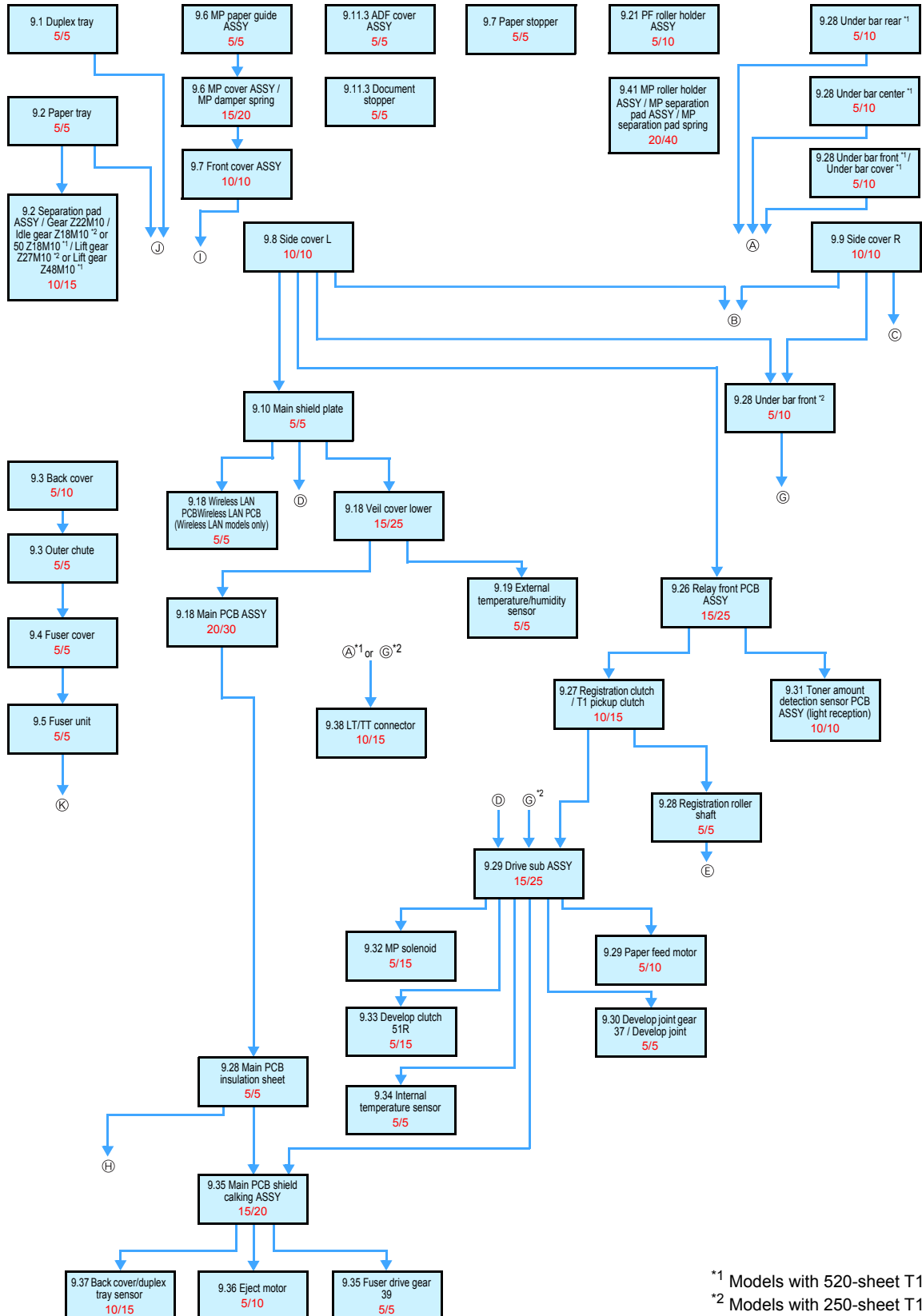

Disassembly / Reassembly (second)

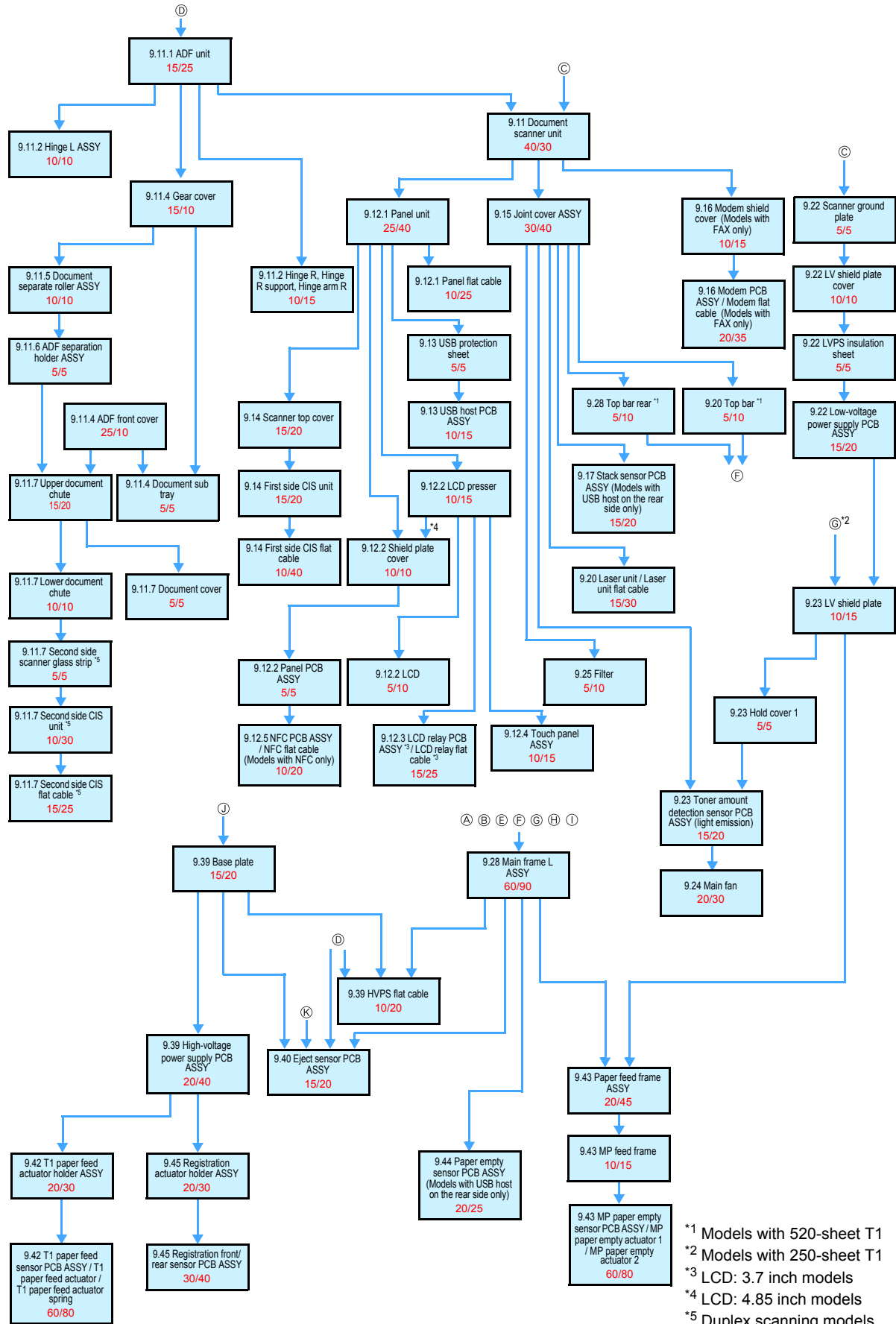

*1 Models with 520-sheet T1
 *2 Models with 250-sheet T1
 *3 LCD: 3.7 inch models
 *4 LCD: 4.85 inch models
 *5 Duplex scanning models

8.2 LT

Disassembly / Reassembly (second)

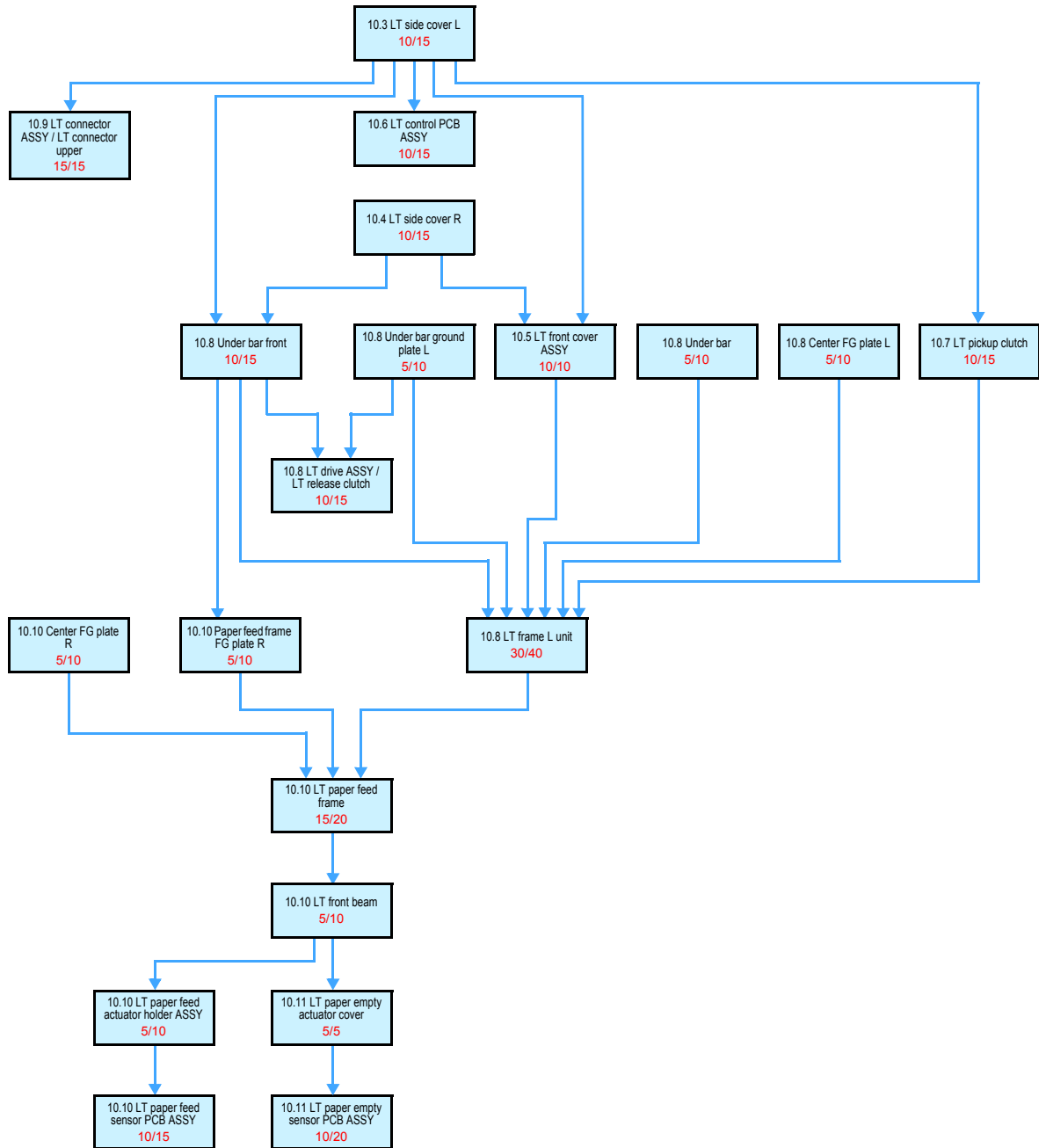

9. DISASSEMBLY PROCEDURE

9.1 Preparation

■ Disconnecting Cables and removing Accessories

Prior to proceeding with the disassembly procedure,

- (1) Disconnect the following:
 - AC cord
 - USB cable (if connected)
 - LAN cable (if connected)
 - Line cord (if connected)
- (2) Remove the following:
 - Paper tray
 - Toner cartridge and Drum unit
 - Duplex tray
 - LAN port cap

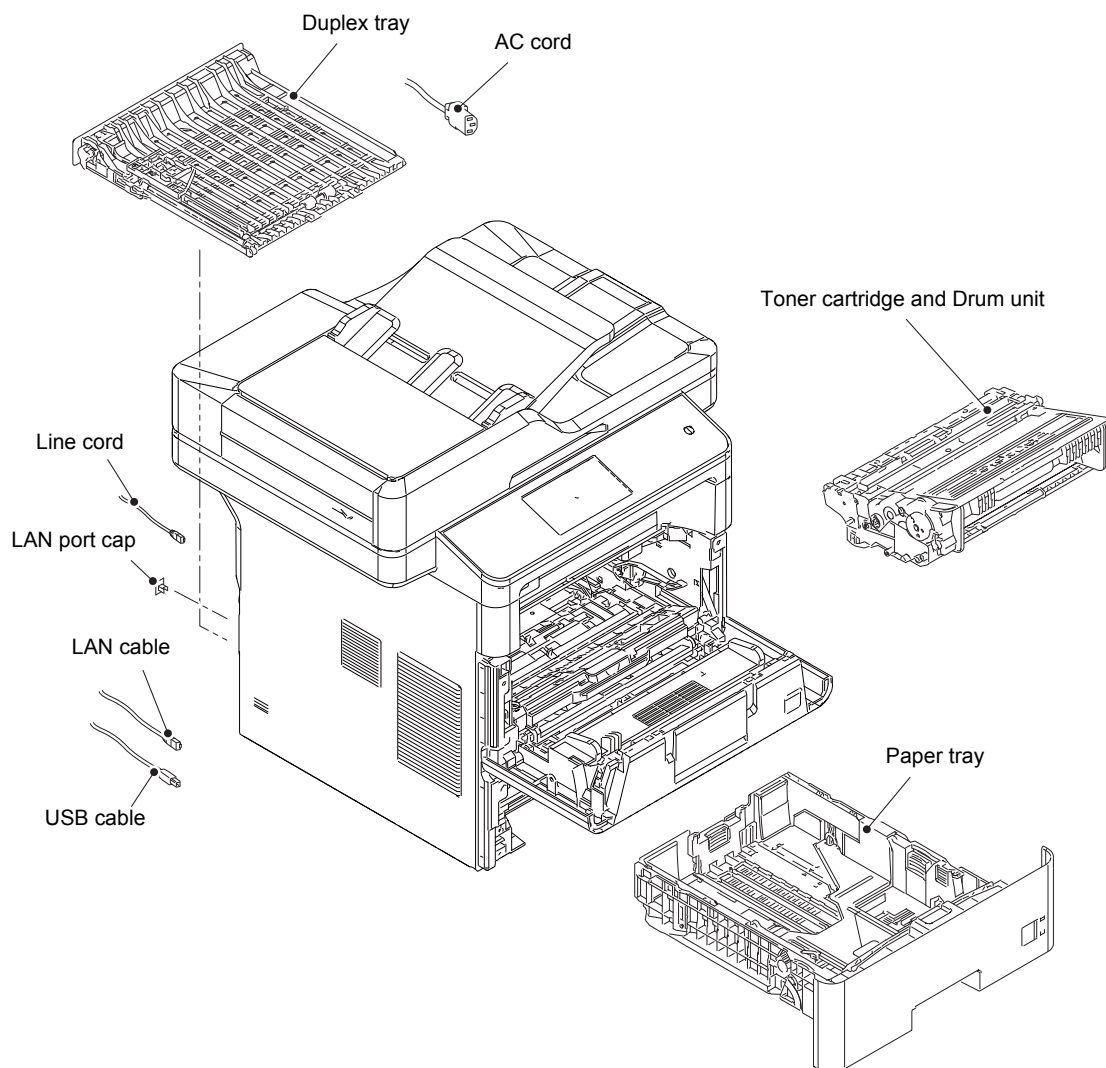

Fig. 3-12

9.2 Paper tray

- (1) Release the two hooks on the separation pad ASSY from the paper tray.
- (2) Push both side arms on the separation pad ASSY inwards to remove the pins, and remove the separation pad ASSY from the paper tray.
- (3) Remove the separation pad spring from the separation pad ASSY.

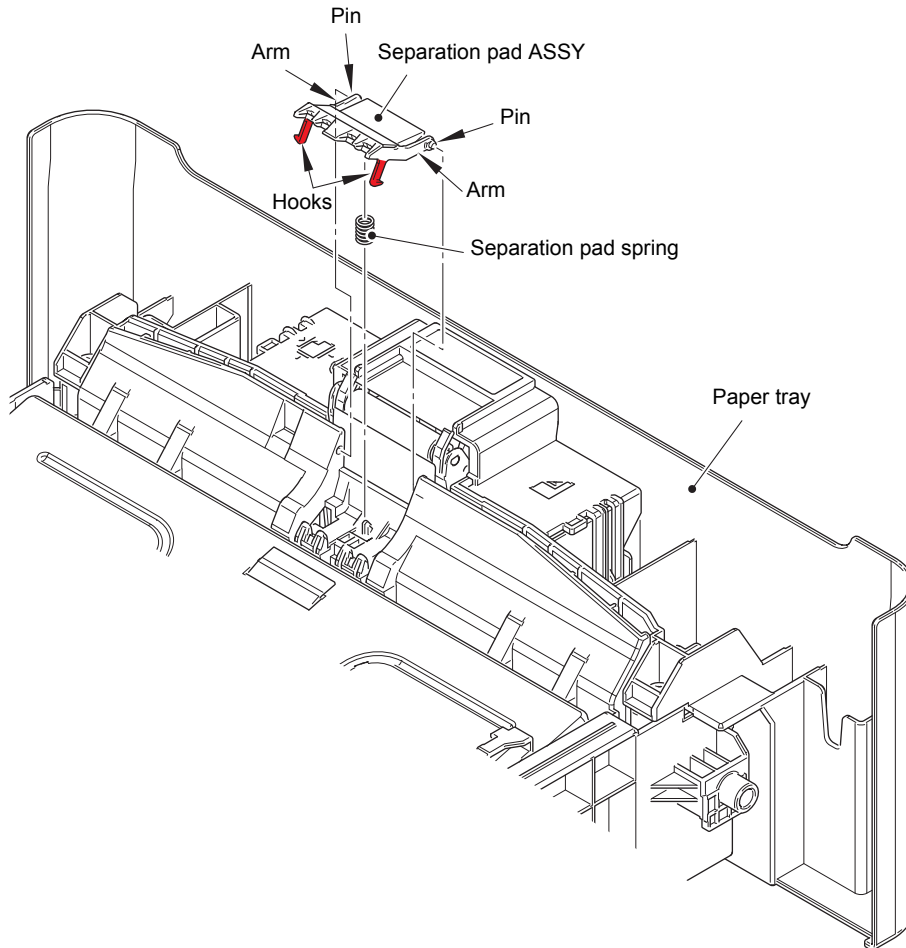

Fig. 3-13

- (4) Push the hook on the lift gear Z27M10 (or lift gear Z48M10) while lifting the plate-up plate, and remove the lift gear Z27M10 (or lift gear Z48M10) from the paper tray.
250-sheet: Lift gear Z27M10
520-sheet: Lift gear Z48M10
- (5) Remove the gear Z22M10 and the idle gear Z18M10 or 50 Z18M10 from the paper tray.
250-sheet: Idle gear Z18M10
520-sheet: Idle gear 50 Z18M10

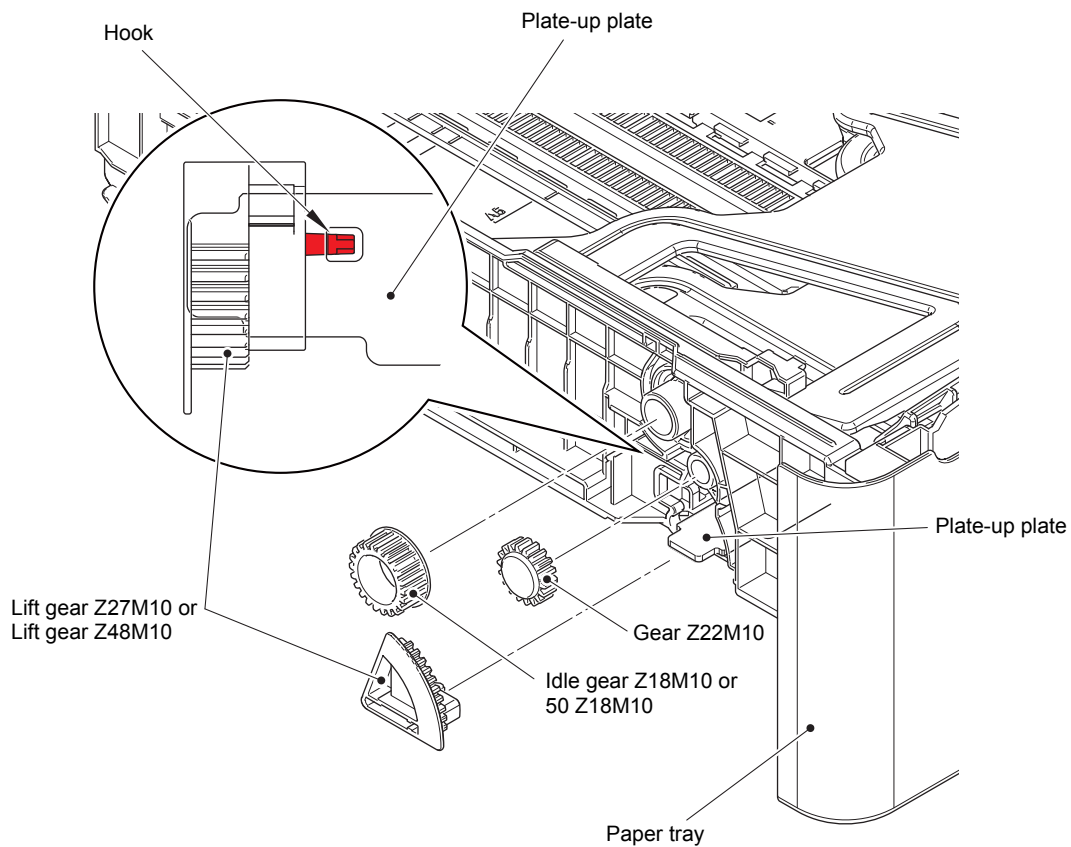

Fig. 3-14

9.3 Back cover / Outer chute

- (1) Open the back cover.
- (2) Push both ribs of the back cover in the direction of the arrows, and remove the two bosses on the outer chute.

Note:

- Be careful not to damage the ribs inside the back cover.

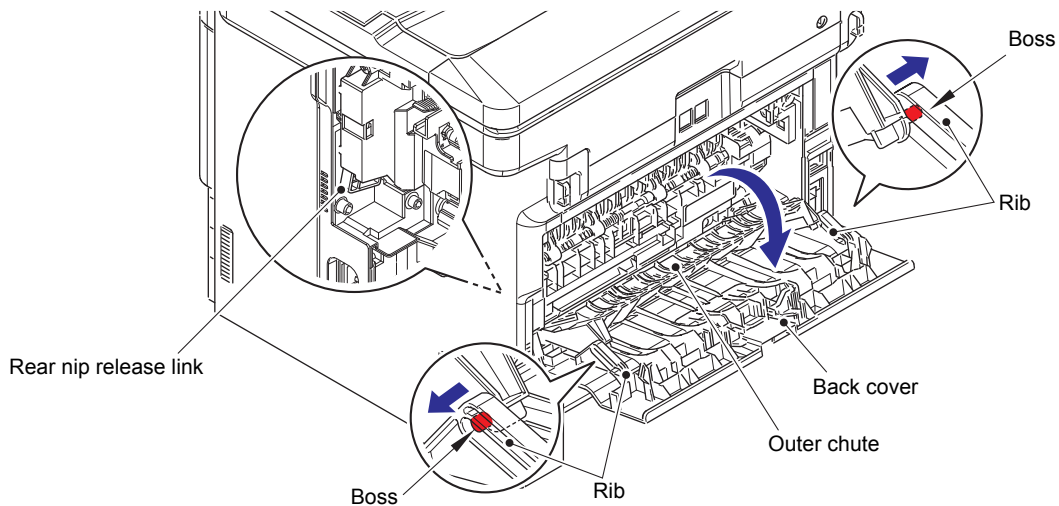

Fig. 3-15

Assembling Note:

- When attaching the back cover, open the front cover and attach the back cover while lifting the rear nip release link.

- (3) Remove the back cover from the boss A, and remove the back cover.
- (4) Open the outer chute approximately 80 degrees. Remove the outer chute from the boss B, and remove the outer chute from the machine.

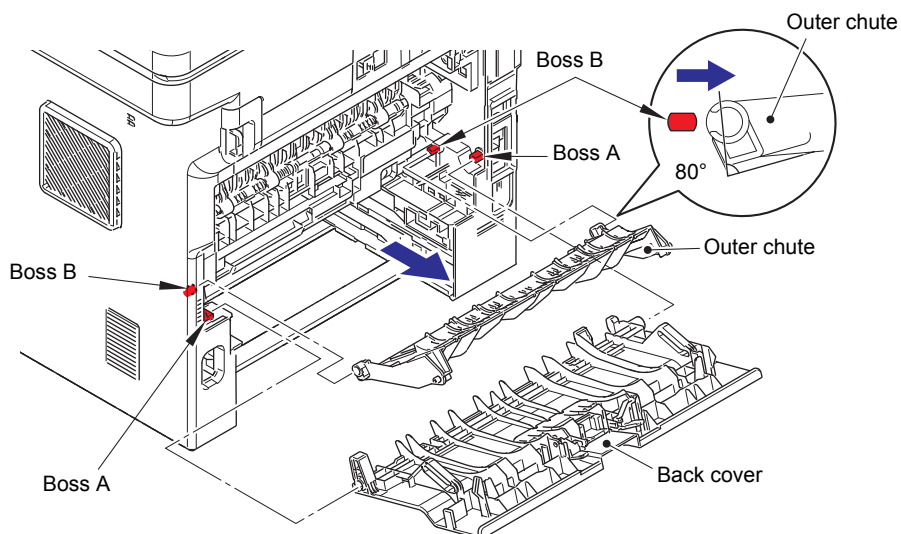

Fig. 3-16

9.4 Fuser cover

- (1) Push the two knobs on the fuser cover, and pull the fuser cover down in the direction of the arrow.
- (2) Remove the fuser cover from the bosses on the fuser unit, and remove the fuser cover.

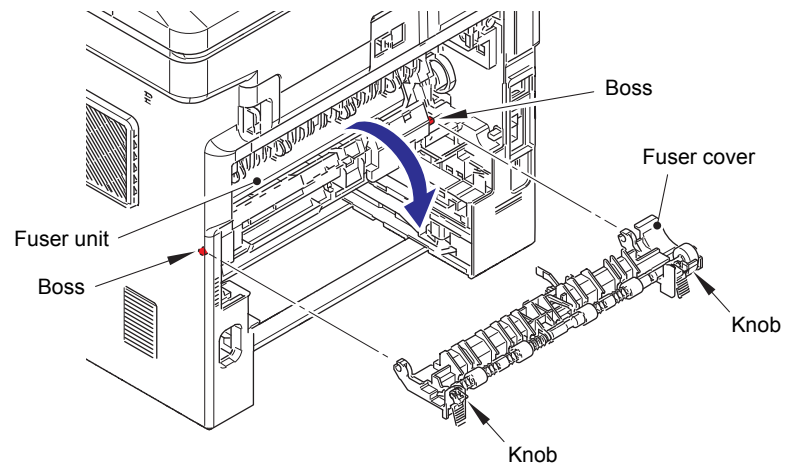
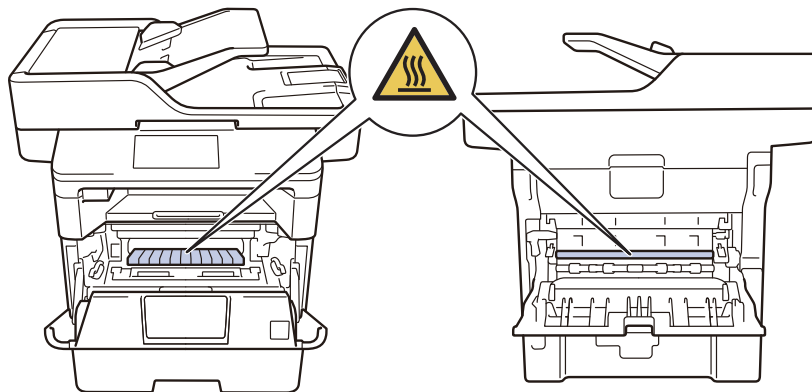

Fig. 3-17

9.5 Fuser unit

CAUTION

Some parts inside the machine are extremely hot immediately after the machine is used. When opening the front cover ASSY or back cover to access any parts inside the machine, never touch the shaded parts shown in the following figures.



Note:

- Do not touch the fuser unit film directly. It may cause the fuser unit failure.

- (1) Remove the tapite bind B M4x12 screw, and remove the fuser unit line cover R.
- (2) Open the front cover, and release the nip of the pressure roller.
- (3) Slide the lower rear nip release link in the direction of the arrow 3b while pulling it in the direction of the arrow 3a to remove the rear nip release link.
- (4) Remove the tapite pan B M4x14 screw. Release the hook, and remove the fuser unit line cover L.

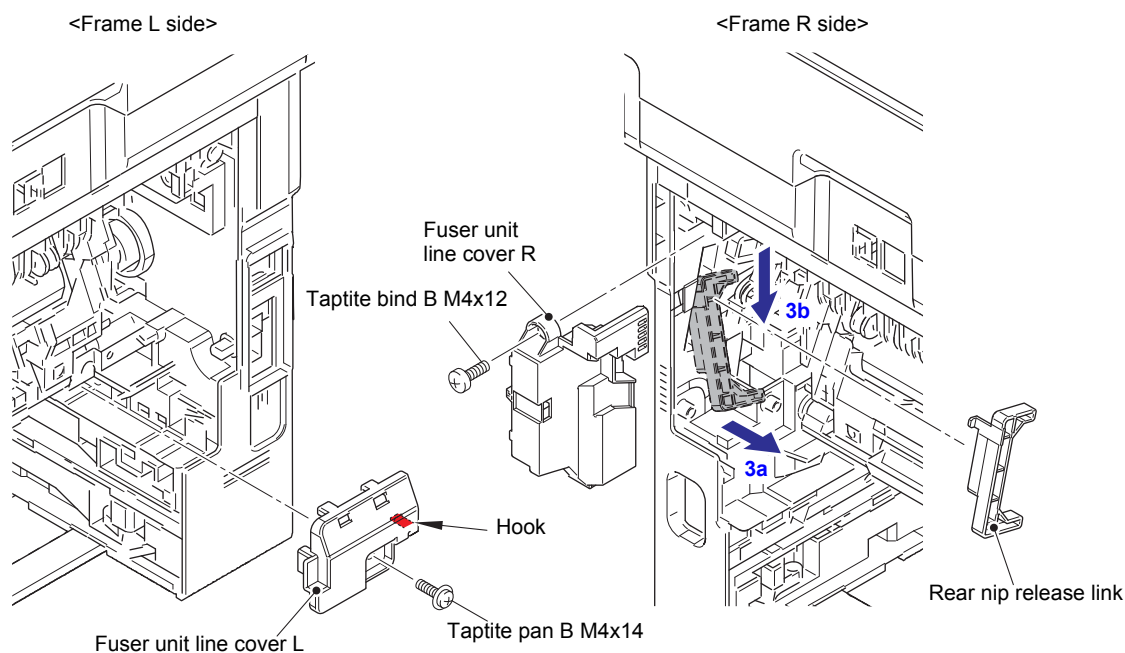

Fig. 3-18

- (5) Release the heater harness of the fuser unit from the securing fixtures, and disconnect it from the low-voltage heater harness.

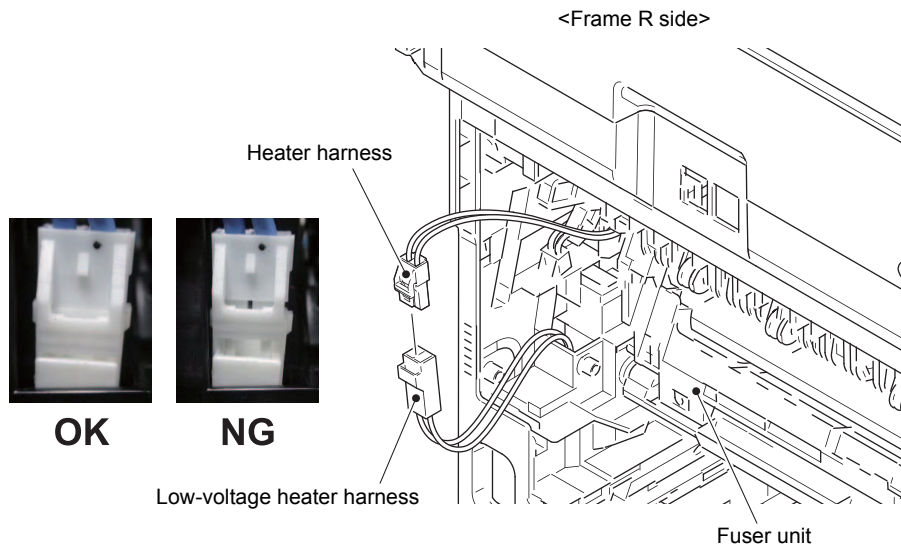

Fig. 3-19

Assembling Note:

- After connecting the heater harness, pull the connector on the heater harness side while holding the connector on the low-voltage heater harness side to make sure it is locked.

Harness routing: Refer to "11. Rear side of the machine".

- (6) Disconnect the center thermistor harness and the side thermistor harness from the eject sensor PCB ASSY.

Note:

- When disconnecting the harness, hold the top of the PCB connector to prevent the PCB connector being damaged.

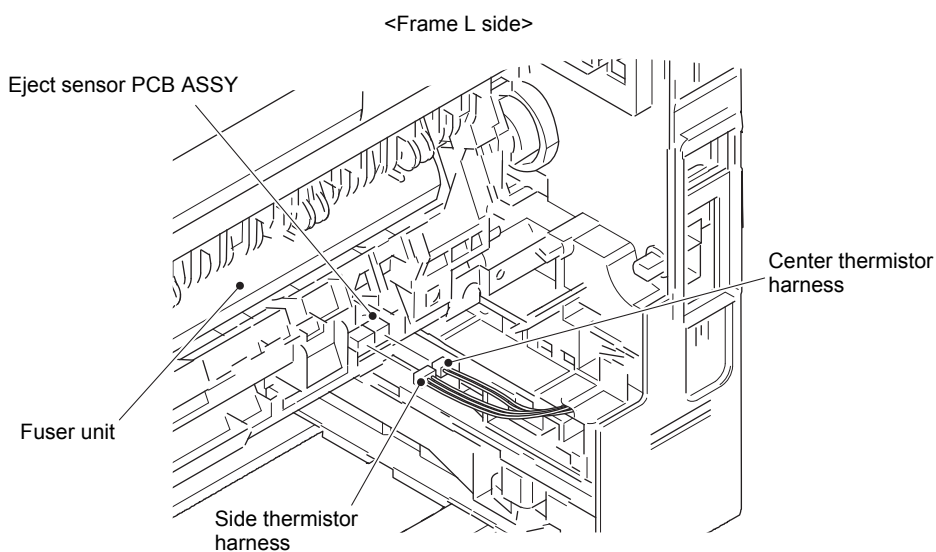

Fig. 3-20

Harness routing: Refer to "11. Rear side of the machine".

- (7) Close the front cover and return the pressure roller nip.
- (8) Remove the taptite pan B M4x14 screw, and remove the fuser unit.

Note:

- Make sure that the front cover is closed when removing the fuser unit.

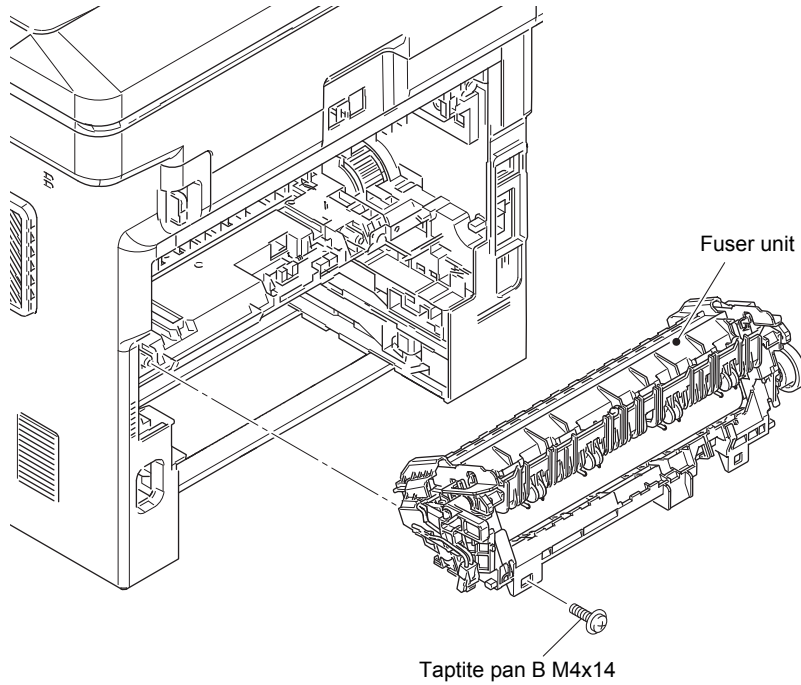

Fig. 3-21

9.6 MP cover ASSY

- (1) Open the MP cover ASSY.
- (2) Remove the two hooks on the MP paper guide ASSY from the two bosses on the front cover ASSY.

Note:

- When removing the MP paper guide ASSY from the bosses on the front cover ASSY, pull it out strongly in the direction of the arrows.

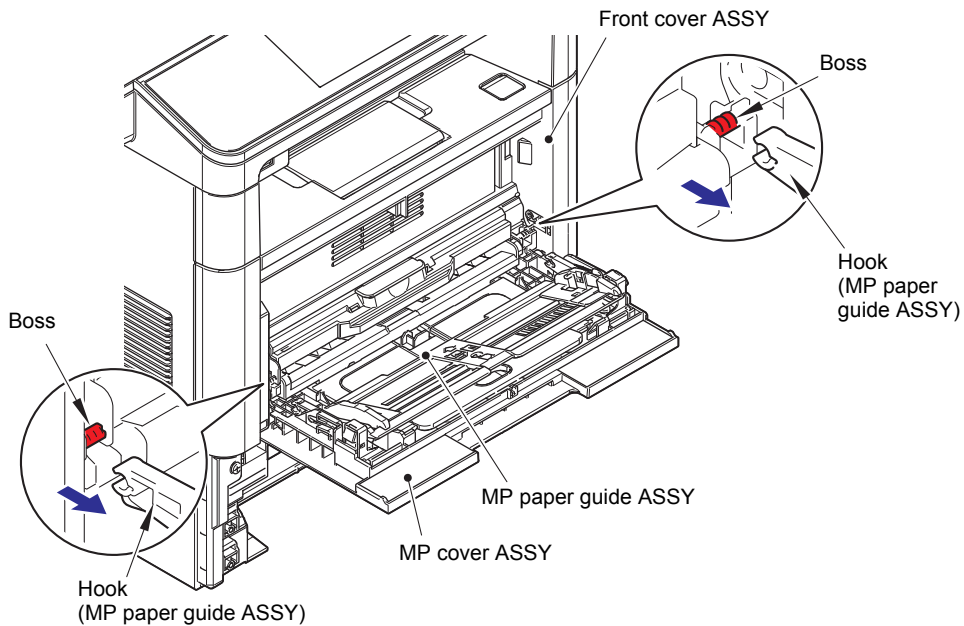

Fig. 3-22

- (3) Open the front cover ASSY, and release the hook on the MP damper spring from the front cover ASSY.

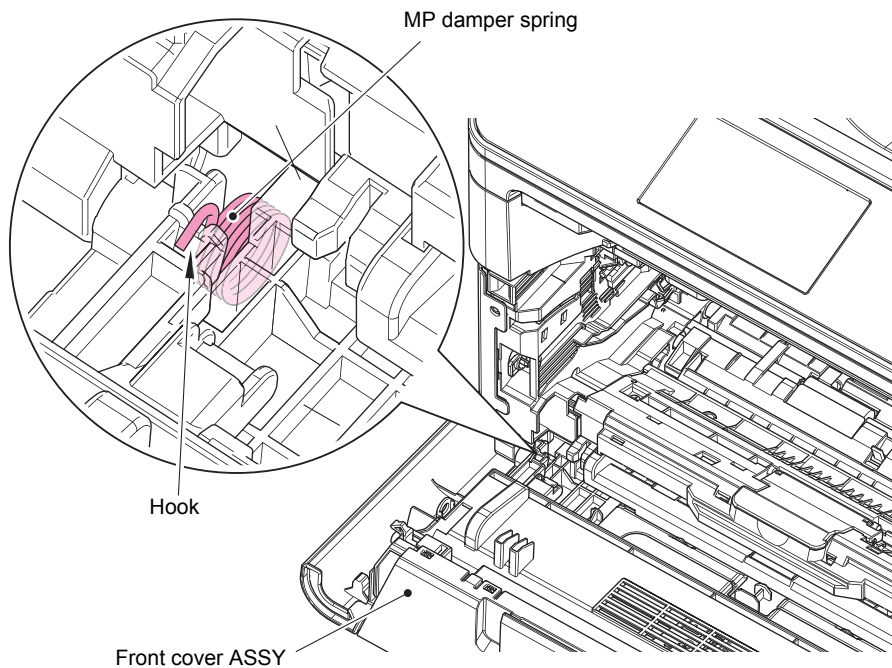

Fig. 3-23

- (4) Close the front cover ASSY. Remove the two bosses on the MP cover ASSY, and remove the MP cover ASSY from the front cover ASSY.

Note:

- Remove the MP cover ASSY while pushing "A" on the front cover ASSY in the direction of the arrow.

- (5) Remove the MP damper spring from the MP cover ASSY.

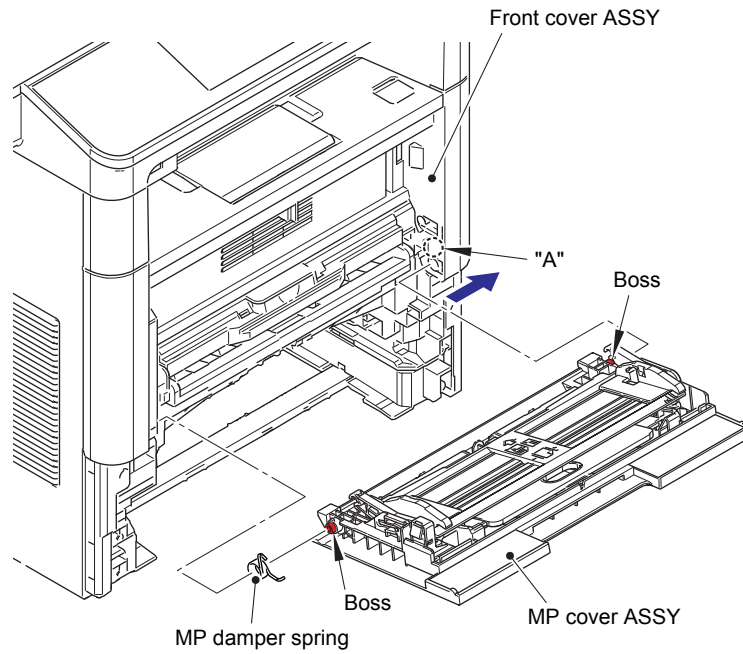

Fig. 3-24

Assembling Note:

- Attach the MP damper spring as described in the figure below.

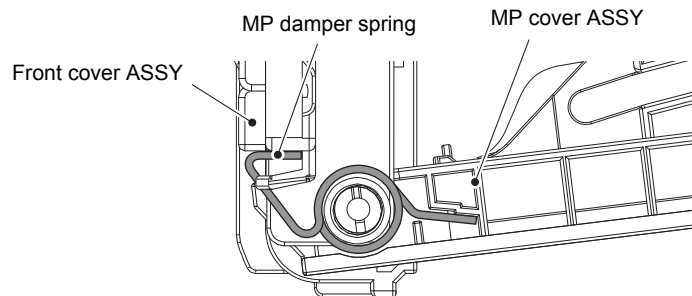

Fig. 3-25

9.7 Front cover ASSY

- (1) Push the front cover release button, and open the front cover.
- (2) Release the two hooks, and remove the develop joint link from the front cover ASSY.
- (3) Release the hook, and remove the nip release link from the front cover ASSY.

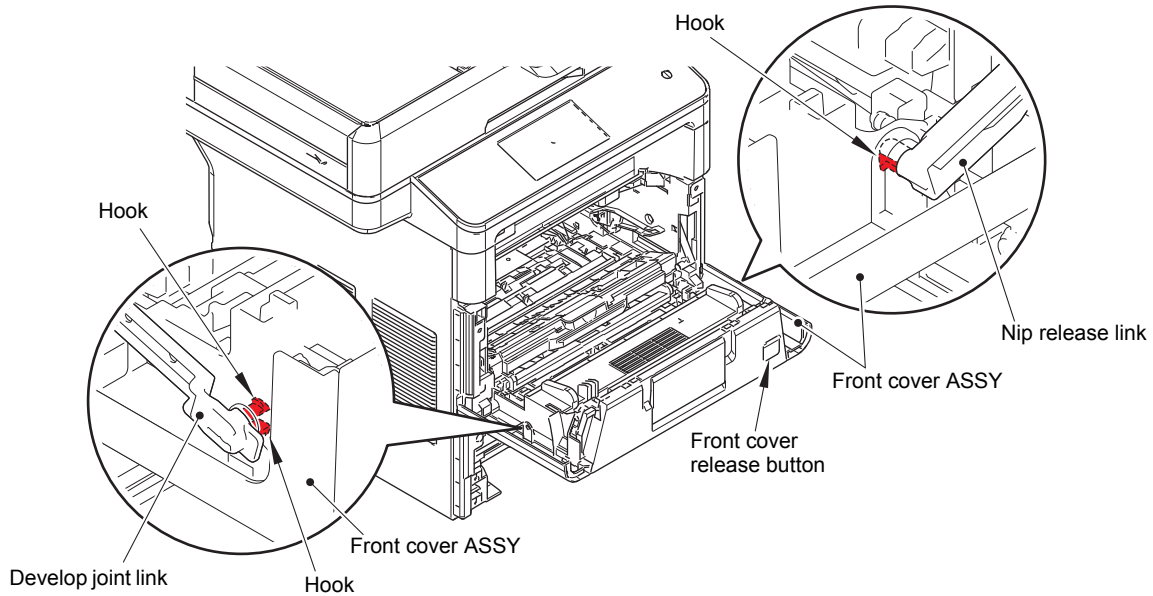

Fig. 3-26

- (4) Remove the front cover ASSY from the two bosses.

Note:

- When removing the front cover ASSY, push "A" on the front cover ASSY in the direction of the arrow 4A, and slide the front cover ASSY in the direction of the arrow 4B to remove it.

- (5) Remove the two bosses on the paper stopper, and remove the paper stopper from the front cover ASSY.

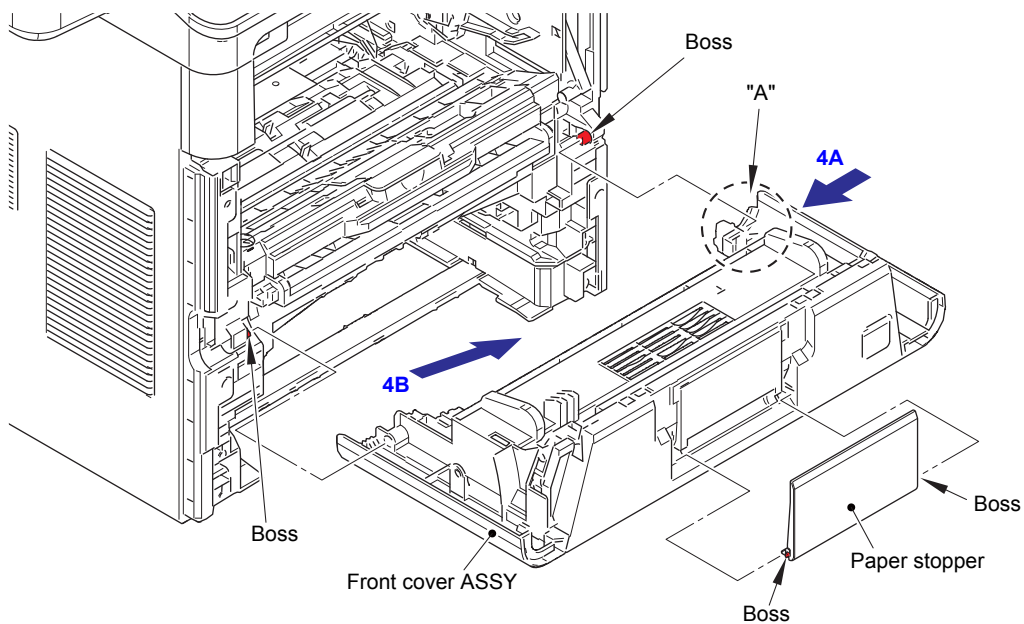

Fig. 3-27

9.8 Side cover L

- (1) Remove the two Taptite bind B M4x12 screws. Release the hook A, B and C of the arrow A to C in this order, and remove the side cover L.

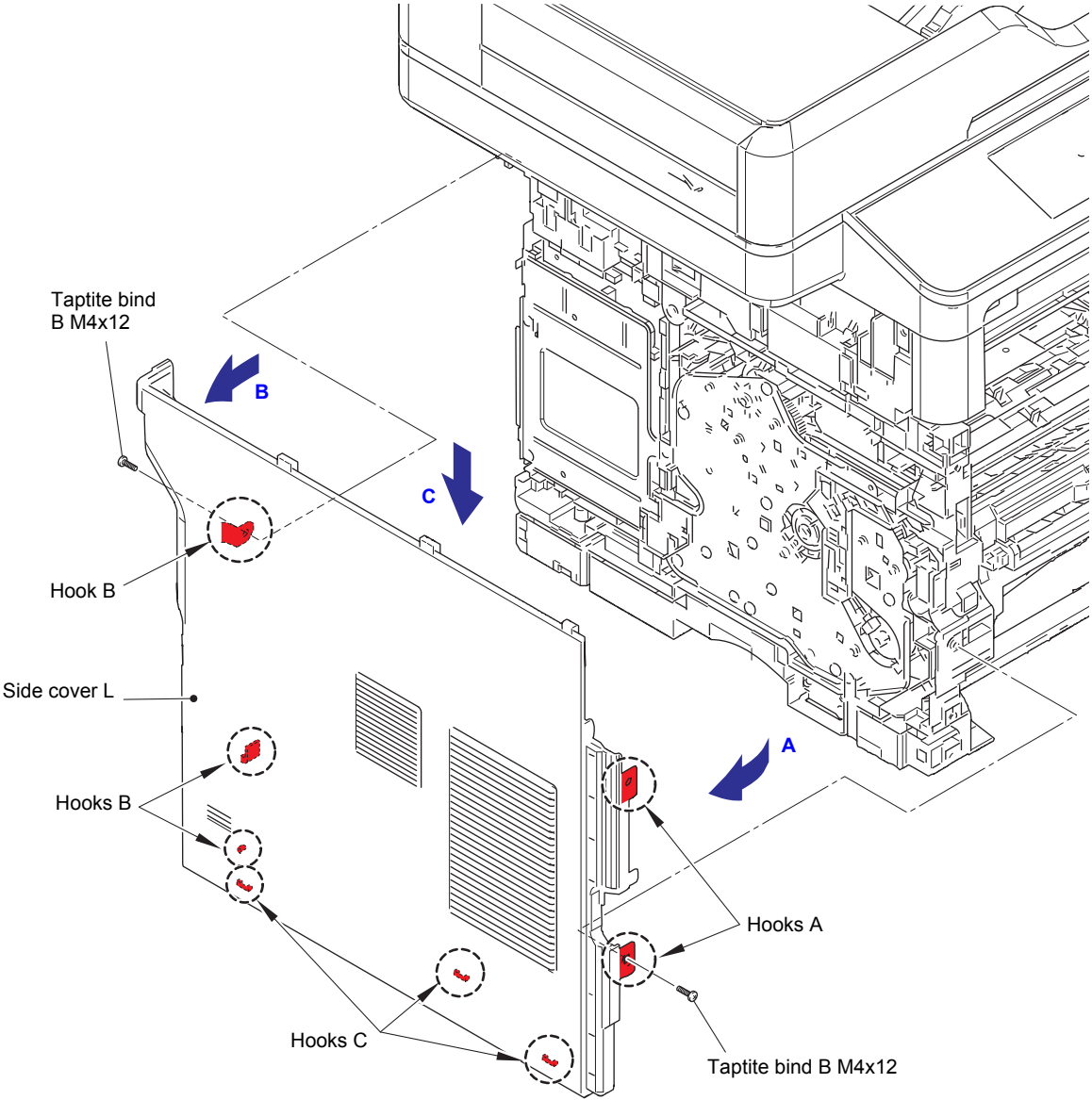

Fig. 3-28

9.9 Side cover R

- (1) Remove the two Taptite bind B M4x12 screws. Release the hook A, B and C of the arrow A to C in this order, and remove the side cover R.

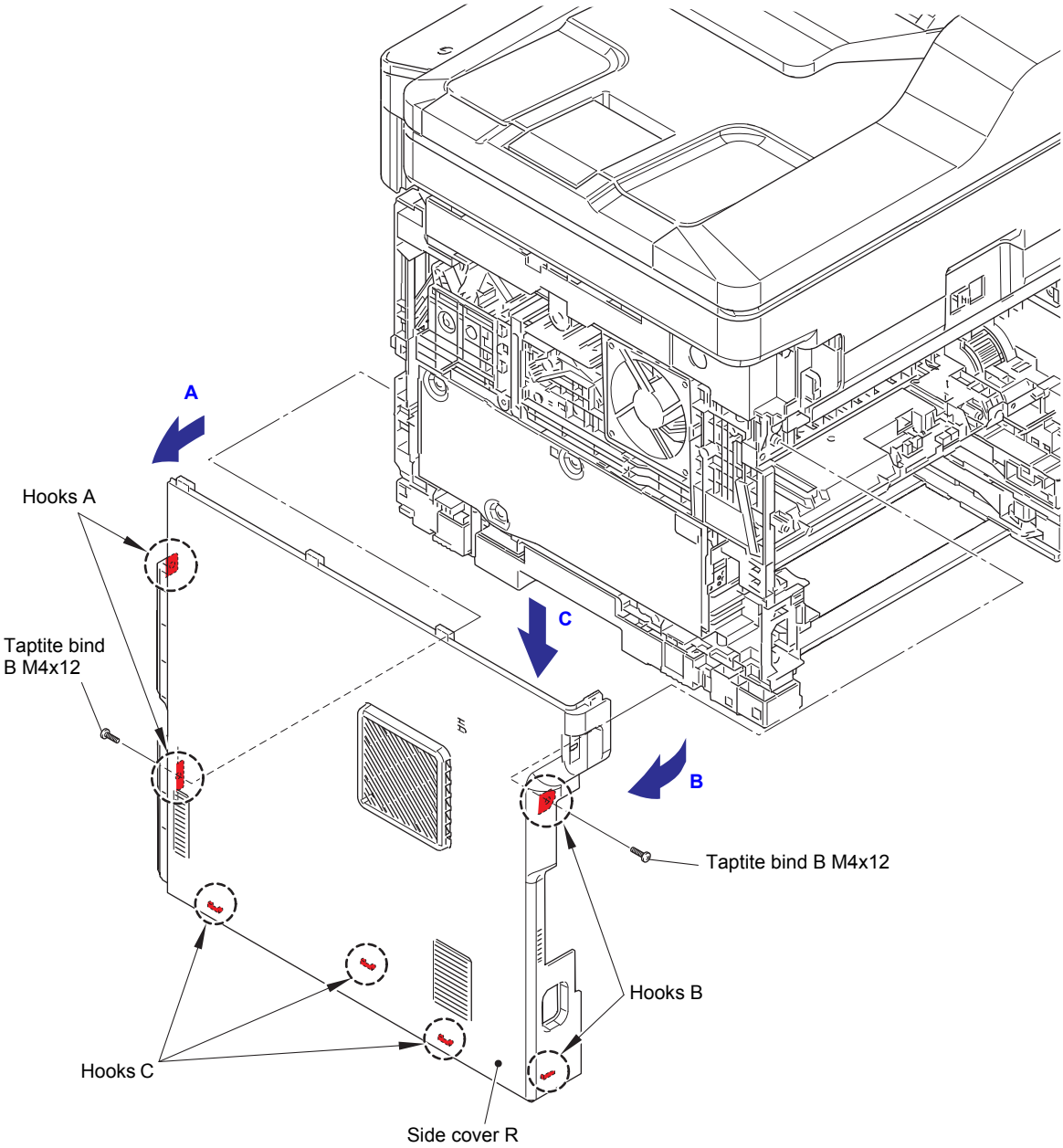

Fig. 3-29

9.10 ADF/document scanner unit

- (1) Remove the tape to remove the modem FG harness L from the main shield plate.

Assembling Note:

- Attach the modem FG harness L on the right side than “A” using a tape.

- (2) Remove the three screw cup M3x8 screws (Black), and remove the ADF FG harness, FB FG harness, modem FG harness L and main shield plate.
- (3) Remove the taptite cup S M3x8 SR screw, and remove the panel FG harness.

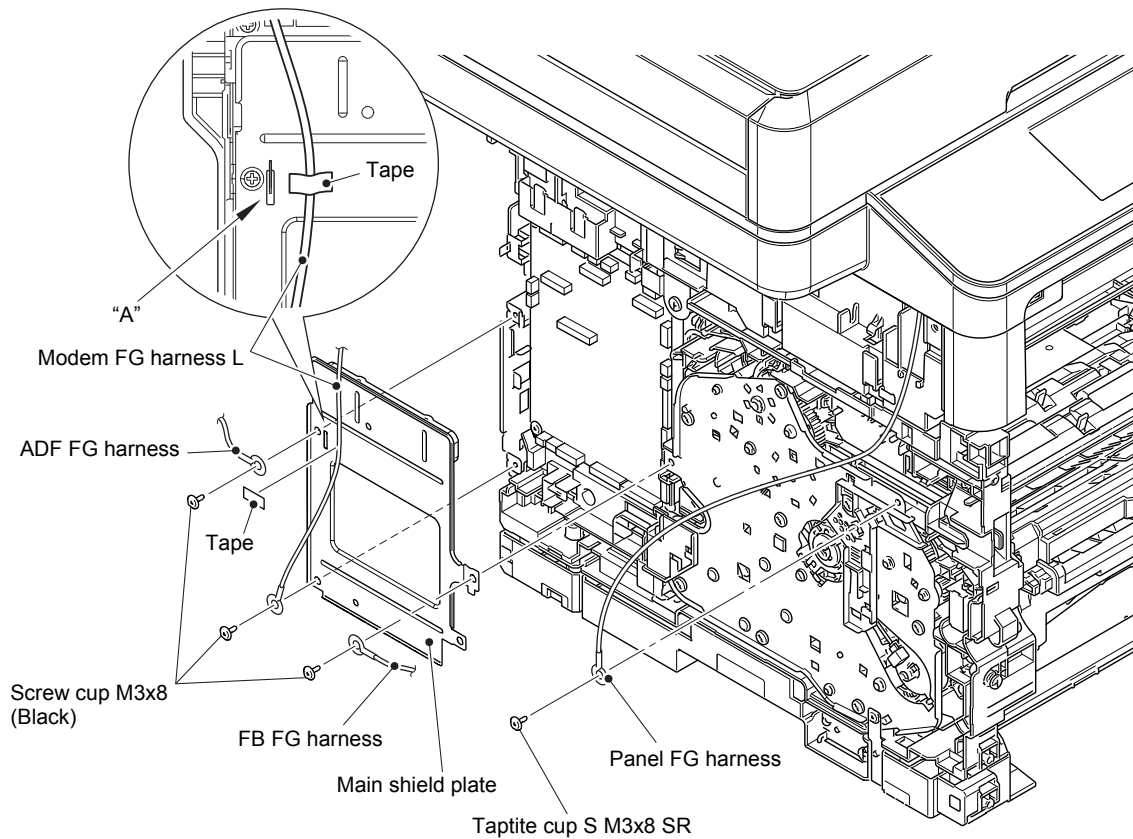

Fig. 3-30

Harness routing: Refer to [“1. ADF unit - Main PCB ASSY”](#), [“2. Document scanner unit - Main PCB ASSY”](#).

- (4) Disconnect the FB motor harness and ADF sensor harness from the main PCB ASSY. Open the main PCB insulation sheet, and release each harness from the securing fixtures. Release each FG harness from the securing fixtures.
- (5) Disconnect the panel flat cable from the main PCB ASSY, and release it from the securing fixtures.
- (6) Disconnect the first side CIS flat cable and second side CIS flat cable* from the main PCB ASSY, and release them from the securing fixtures.
- (7) Remove the guide sponge from the second side CIS flat cable.

Note:

- While disconnecting the second side CIS flat cable, take off the guide sponge as it is obstructive.
- Be sure to replace the guide sponge with a new one after taking off the guide sponge from the second side CIS flat cable.

- (8) Disconnect the USB host harness from the main PCB ASSY, and release it from the securing fixtures.

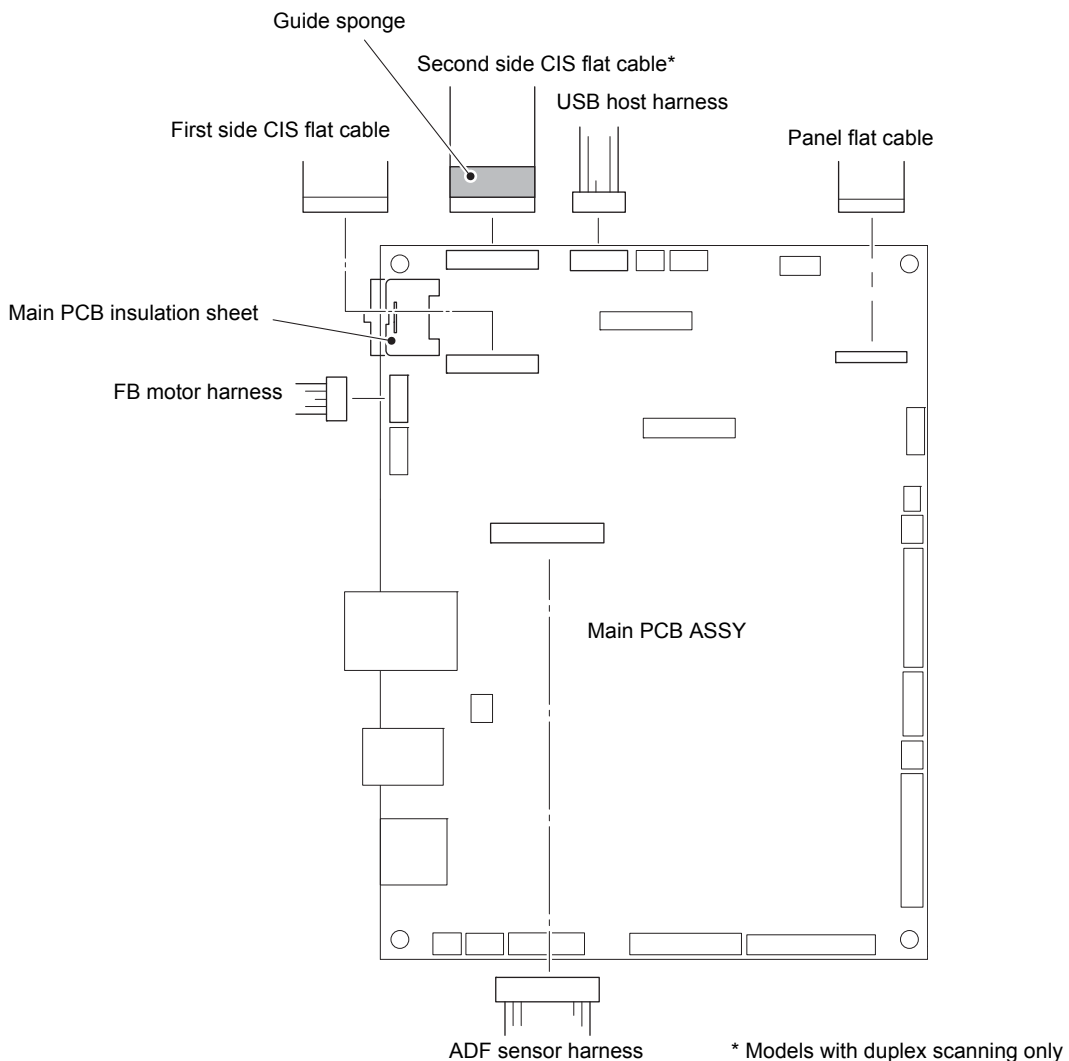

Fig. 3-31

Harness routing: Refer to "1. ADF unit - Main PCB ASSY", "2. Document scanner unit - Main PCB ASSY", "3. Left side of the machine".

- (9) Remove the six taptite bind B M4x12 screws. Release each hook to remove the ADF/document scanner unit.

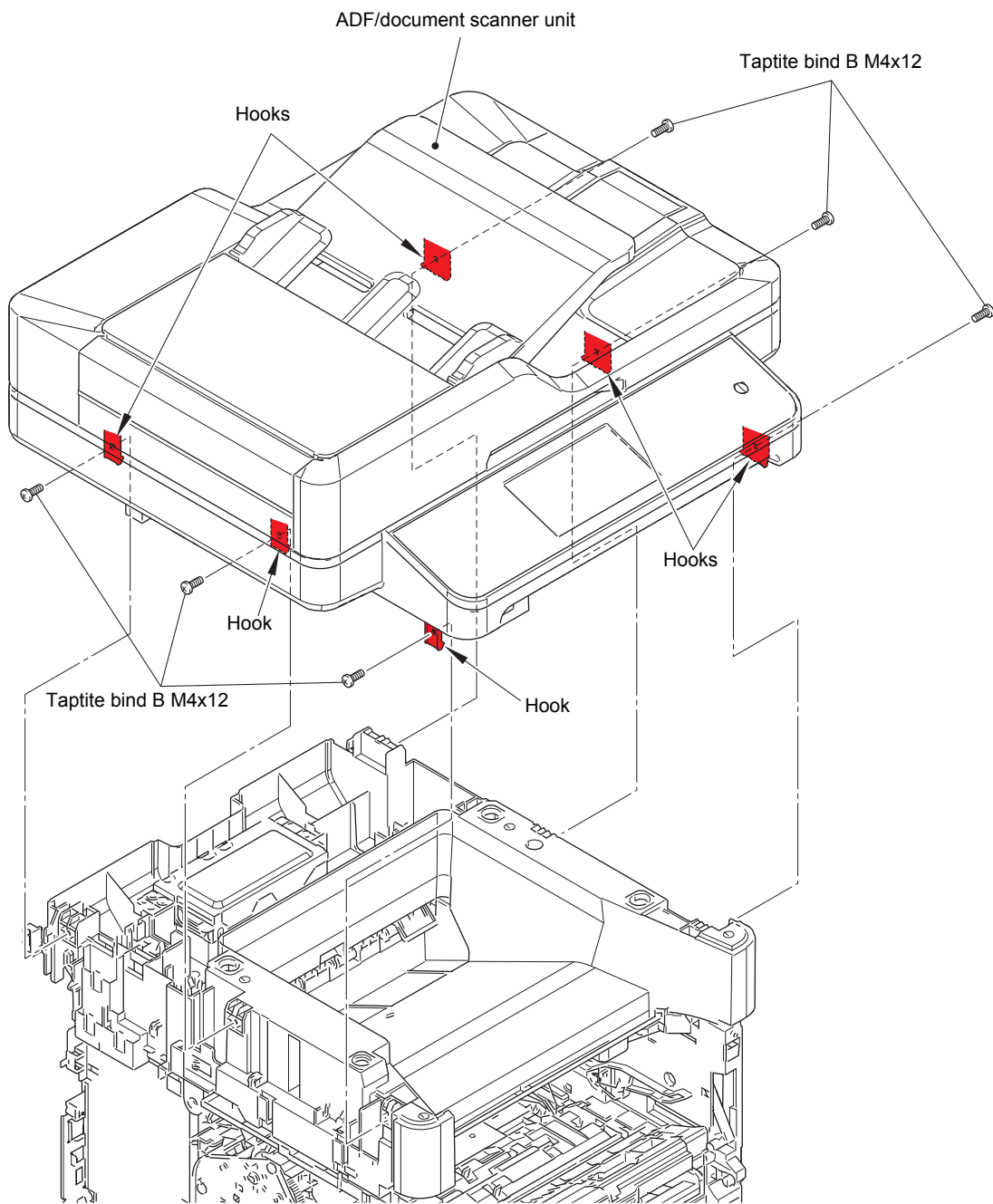

Fig. 3-32

9.11 ADF unit

9.11.1 ADF unit

- (1) Remove the taptite bind B M4x12 screw (black) from the hinge L ASSY.
- (2) Open the ADF unit. Lift the ADF unit and release each hook to remove the flat cable holder from the document scanner unit.
- (3) Lift the ADF unit to remove the ADF unit from the document scanner unit while pressing the hinge R hook. Pull out each harness from the hole.
- (4) Release the ADF sensor harness and second side CIS flat cable* from the flat cable holder.

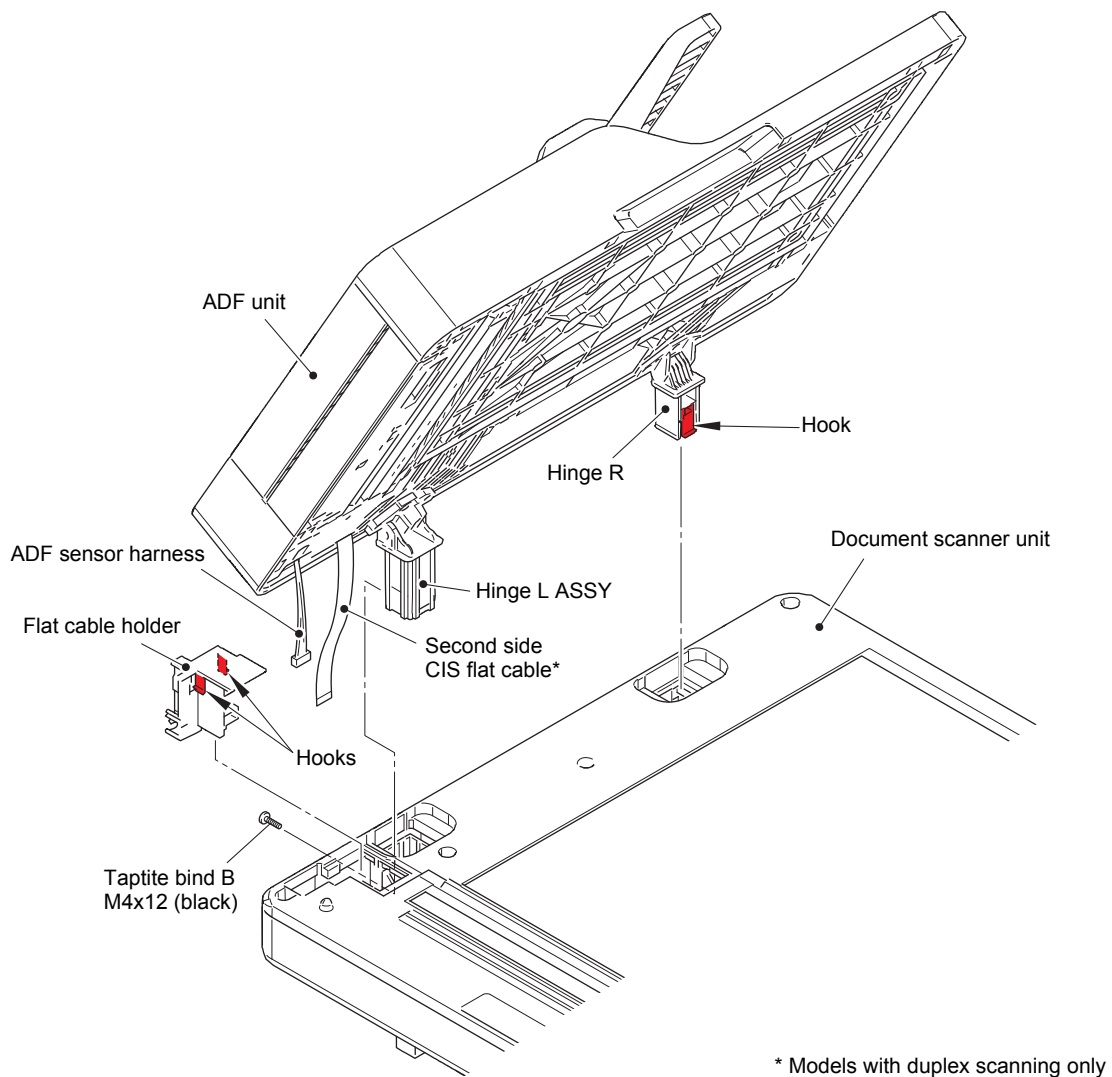

Fig. 3-33

Harness routing: Refer to "1. ADF unit - Main PCB ASSY".

Assembling Note:

- If you replaced the ADF unit, refer to "5. IF YOU REPLACE THE ADF UNIT, FIRST SIDE CIS UNIT, SECOND SIDE CIS UNIT OR DOCUMENT SCANNER UNIT" in chapter 4 and configure the setting.

Assembling Note:

- Connect the ADF sensor harness and second side CIS flat cable* to the flat cable holder as described in the figure below.
- In order to attach the second side CIS flat cable to the flat cable holder, attach it properly in the direction of the arrows.
- For the sticking position of the double-sided tape, refer to the folding diagram of the flat cable, Fig. 3-46, Fig. 3-47 and Fig. 3-48.

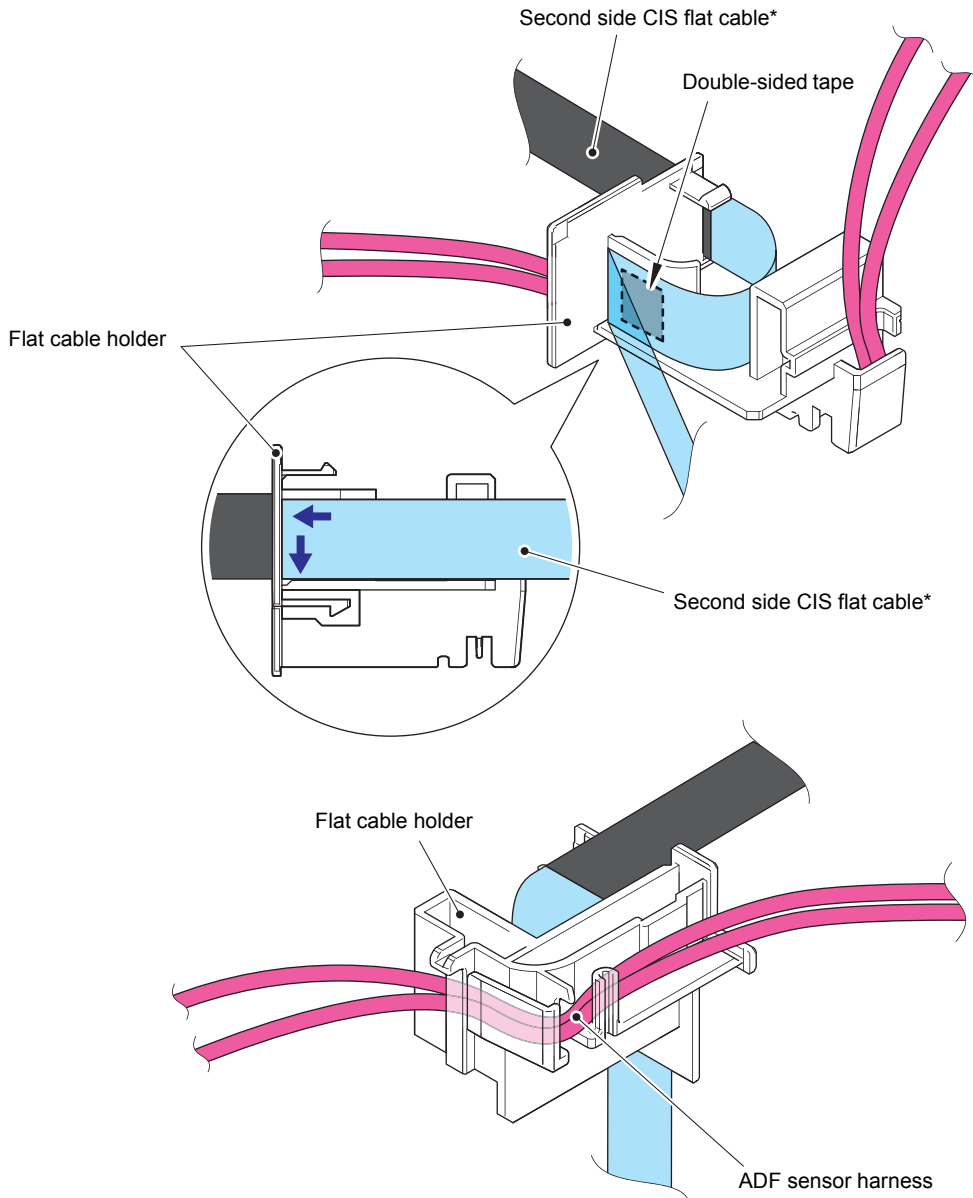

* Models with duplex scanning only

Fig. 3-34

9.11.2 Hinge L ASSY, Hinge R, Hinge R support, Hinge arm R

- (1) Remove the three taptite bind B M4x12 screws to remove the hinge L ASSY from the ADF unit.

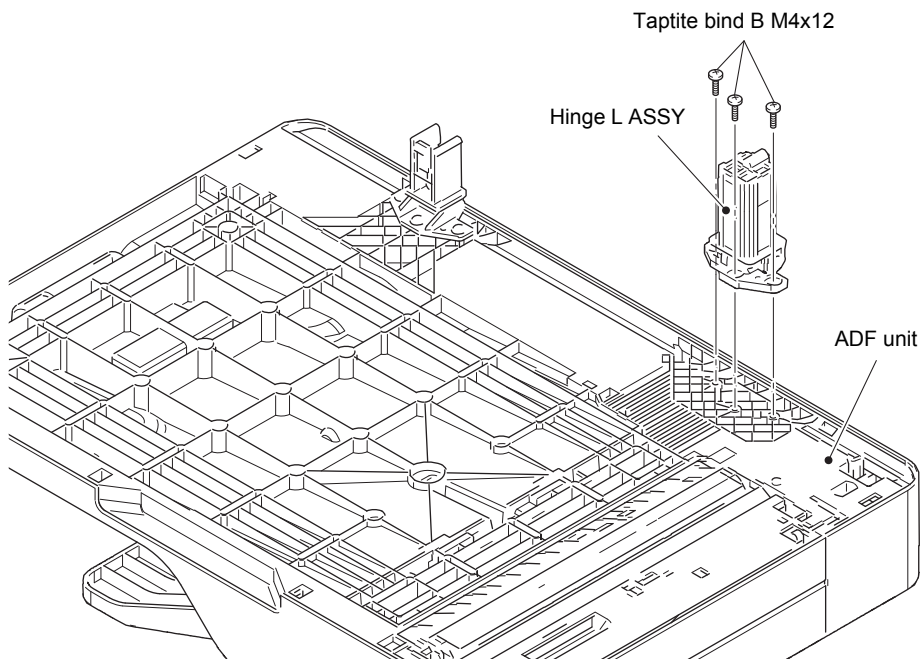

Fig. 3-35

- (2) Remove the taptite cup B M3x10 screw to remove the hinge R support and hinge R from the hinge arm R.
- (3) Remove the three taptite cup B M3x10 screws to remove the hinge arm R from the ADF unit.

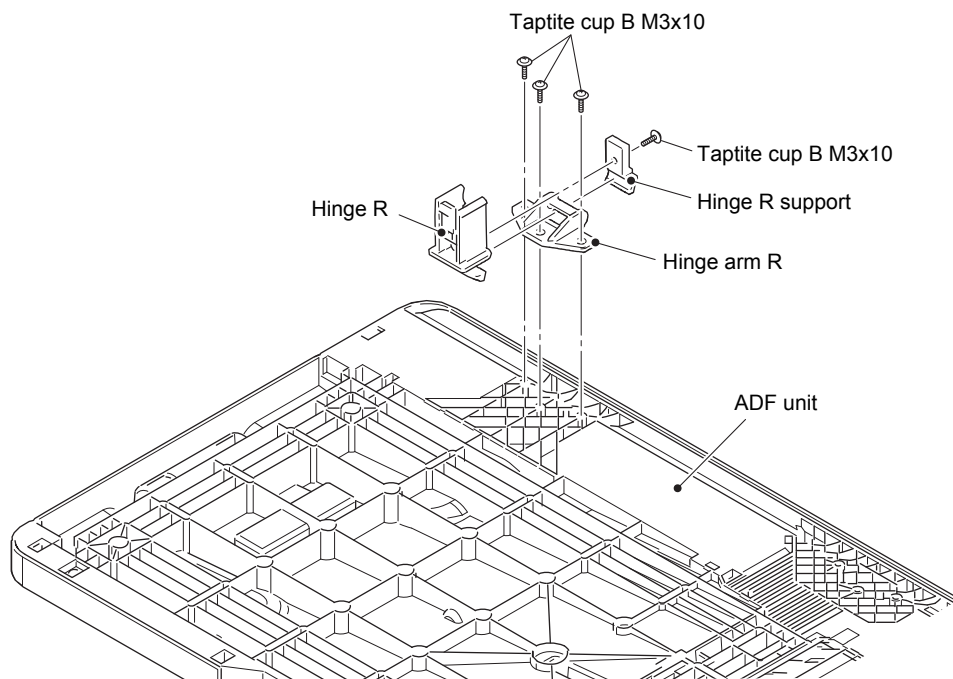

Fig. 3-36

9.11.3 ADF cover ASSY, Document stopper

- (1) Open the ADF cover ASSY. Release the two bosses to remove the ADF cover ASSY from the ADF unit.
- (2) Release the two bosses to remove the document stopper from the ADF unit.

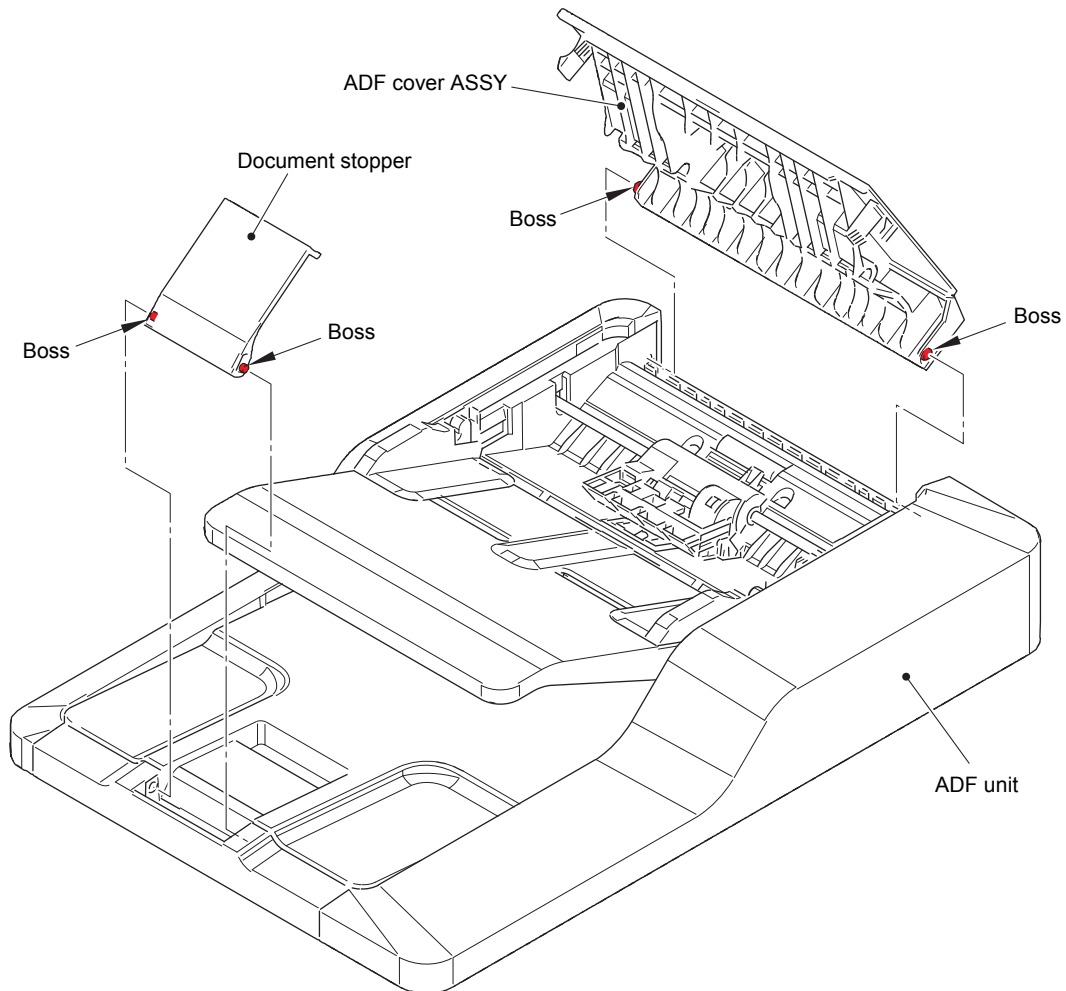

Fig. 3-37

9.11.4 Gear cover, ADF front cover, Document sub tray

- (1) Release each hook to remove the gear cover from the ADF unit.
- (2) Remove the two taptite cup B M3x10 screws. Release each hook to remove the ADF front cover from the ADF unit.

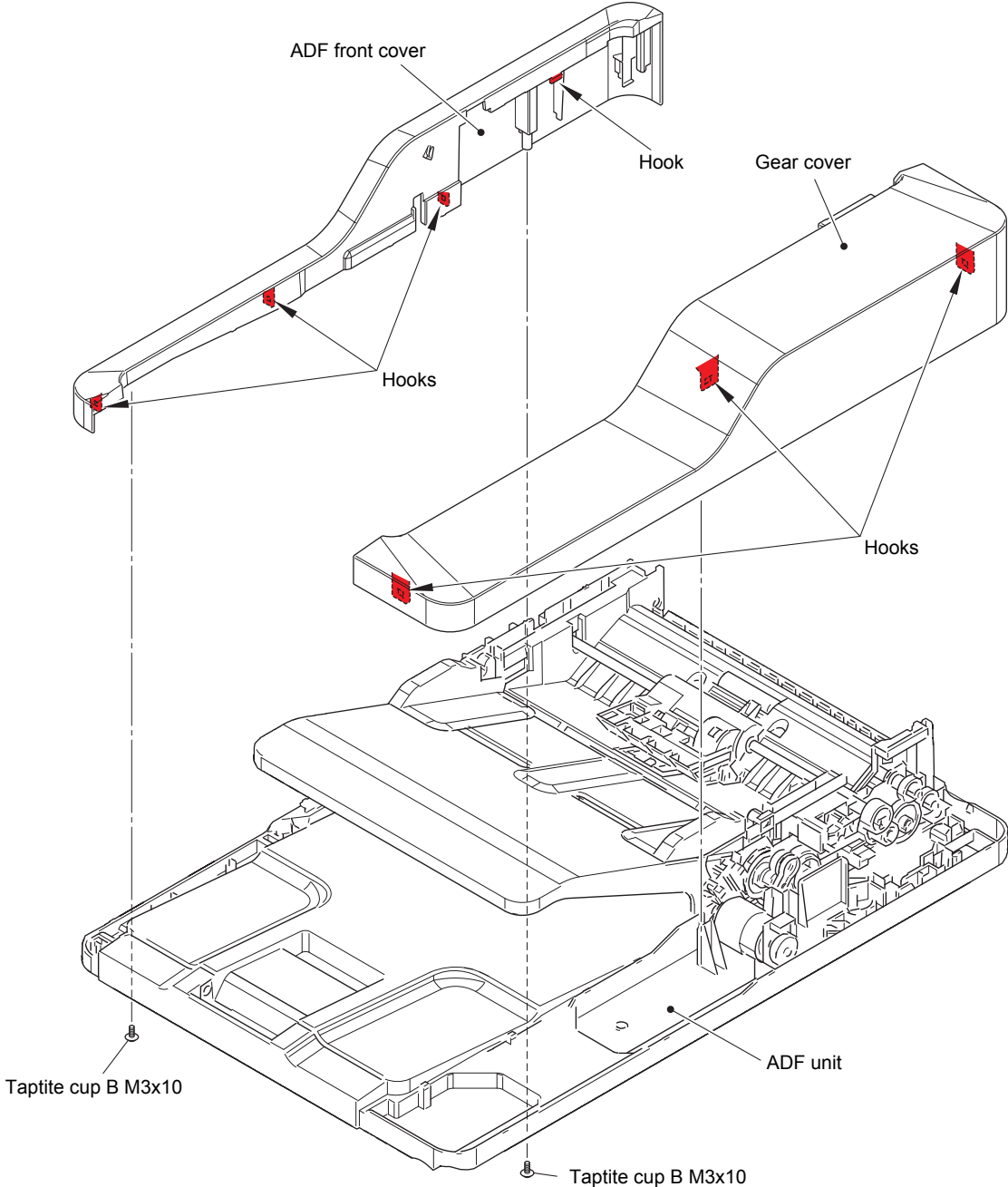

Fig. 3-38

- (3) Open the document sub tray to remove it from the ADF unit by aligning the boss position.

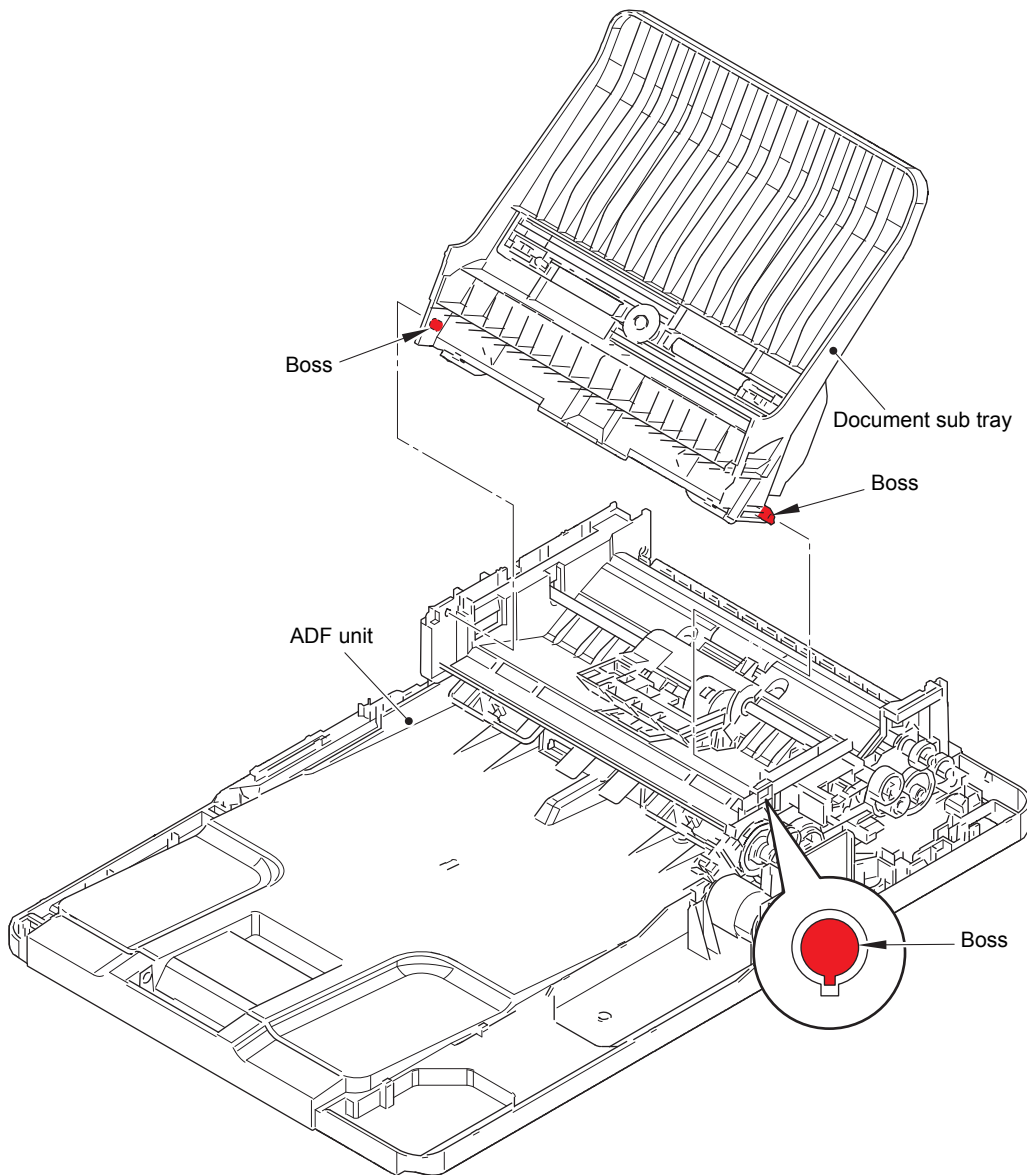

Fig. 3-39

9.11.5 Document separate roller ASSY

- (1) Release the lock of the conductive bushing to remove the document separate roller ASSY from the ADF unit.

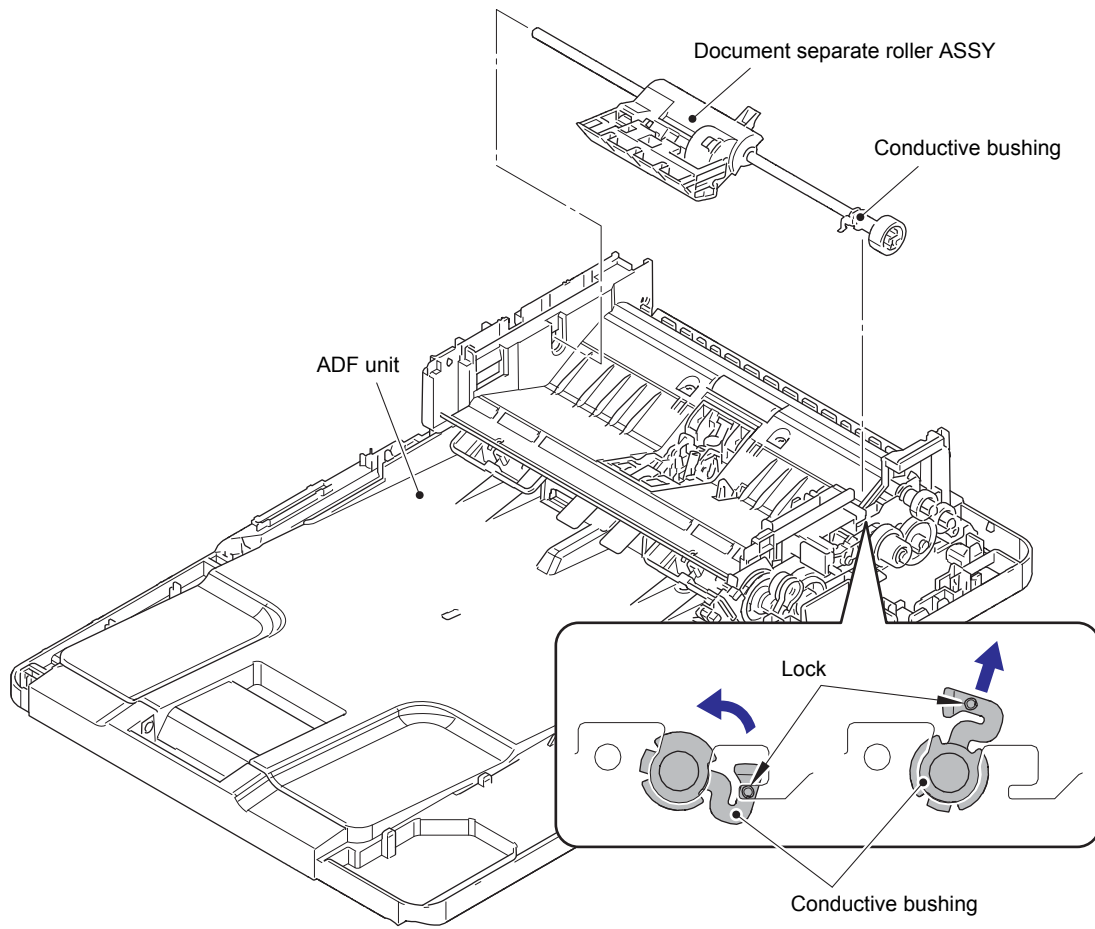

Fig. 3-40

9.11.6 ADF separation holder ASSY

- (1) Remove the taptite cup B M3x10 screw to remove the ADF separation holder ASSY from the ADF unit.

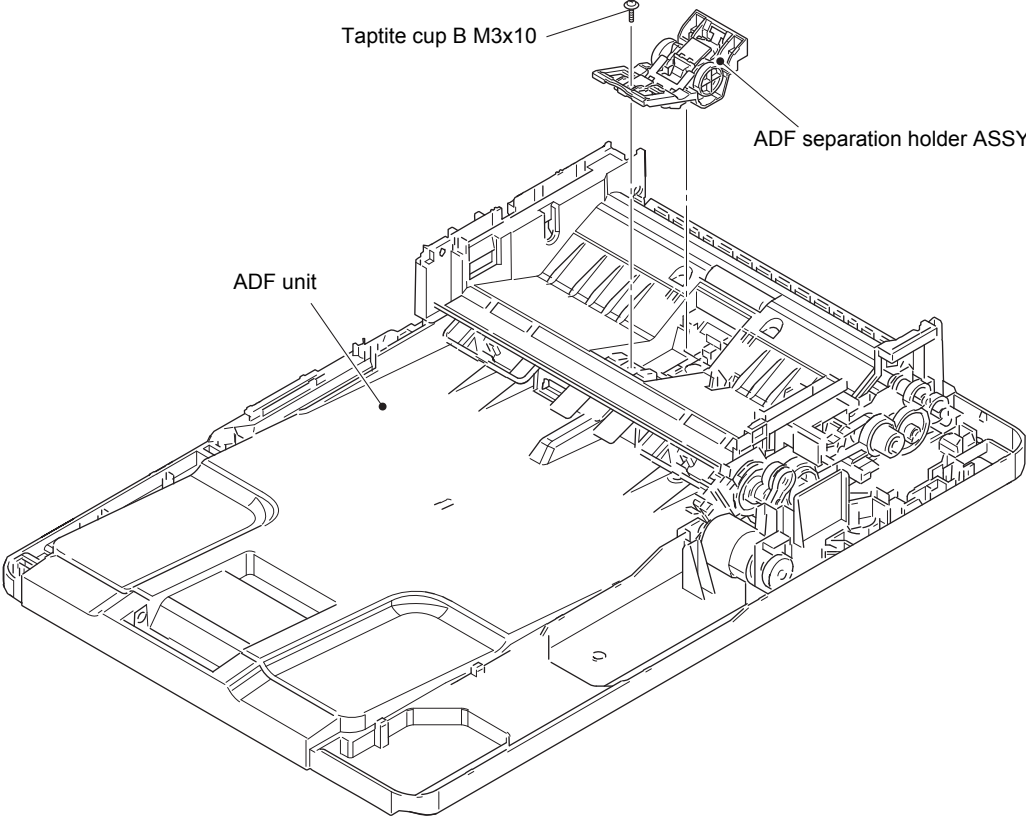

Fig. 3-41

**9.11.7 Second side CIS unit, Second side CIS flat cable
(Models with duplex printing only)**

- (1) Remove the six taptite cup B M3x10 screws to remove the upper document chute from the ADF unit.

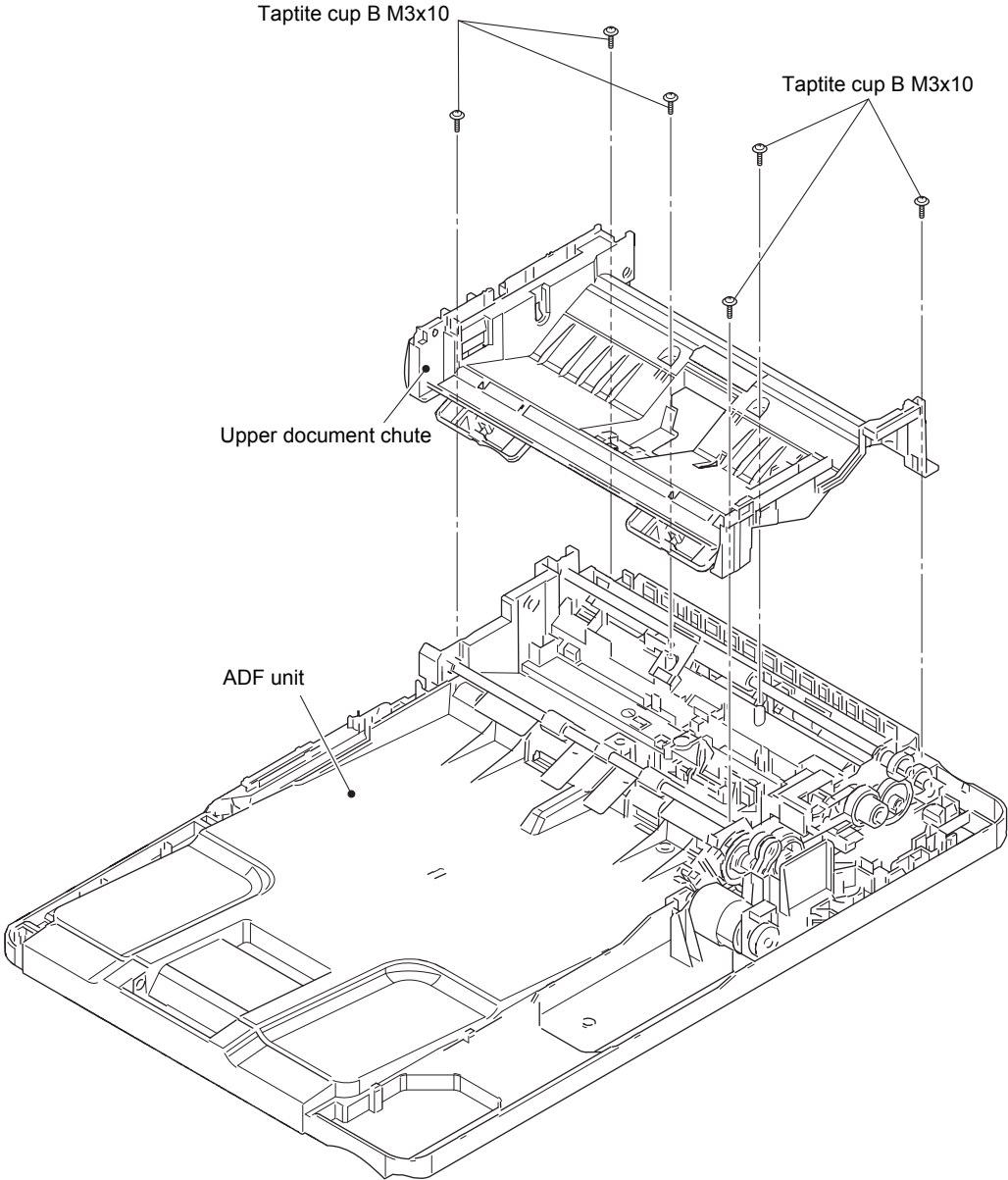

Fig. 3-42

- (2) Release the ADF sensor harness from the securing fixtures, and pull it out from the hole of the document cover.
- (3) Remove the second side CIS flat cable from the double-sided tape, and pull it out from the hole of the document cover.

Note:

- Once the double-sided tape is removed from the second side CIS flat cable, replace it with a new one.

- (4) Remove the lower document chute from the document cover.

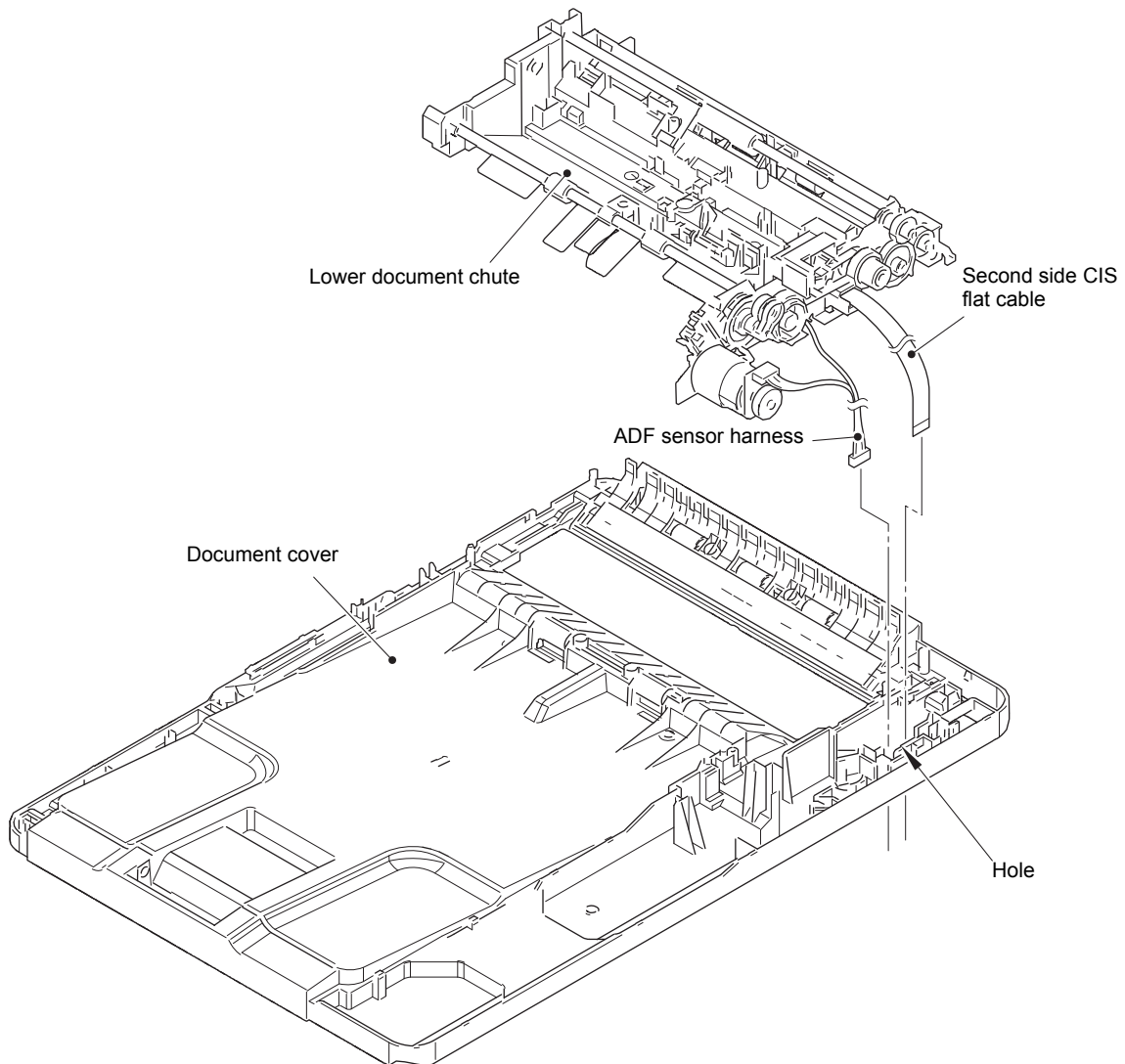

Fig. 3-43

Harness routing: Refer to "1. ADF unit - Main PCB ASSY", "4. ADF unit".

- (5) Lift the hook and slide the second side scanner glass strip in the direction of the arrow 5a. Lift the right end of the second side scanner glass strip to remove it in the direction of the arrow 5b.

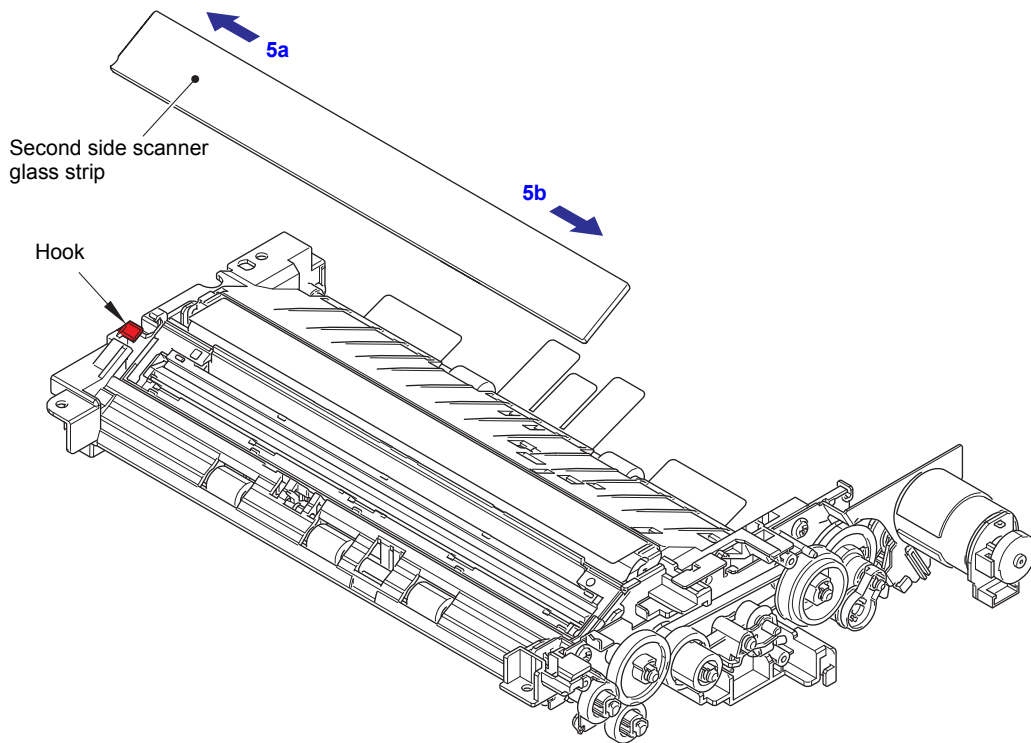

Fig. 3-44

- (6) Remove the CIS spacer R and CIS spacer F from the second side CIS unit.
- (7) Remove the second side CIS unit from the lower document chute, and pull out the second side CIS flat cable from the two holes of the lower document chute.
- (8) Disconnect the second side CIS flat cable from the second side CIS unit.

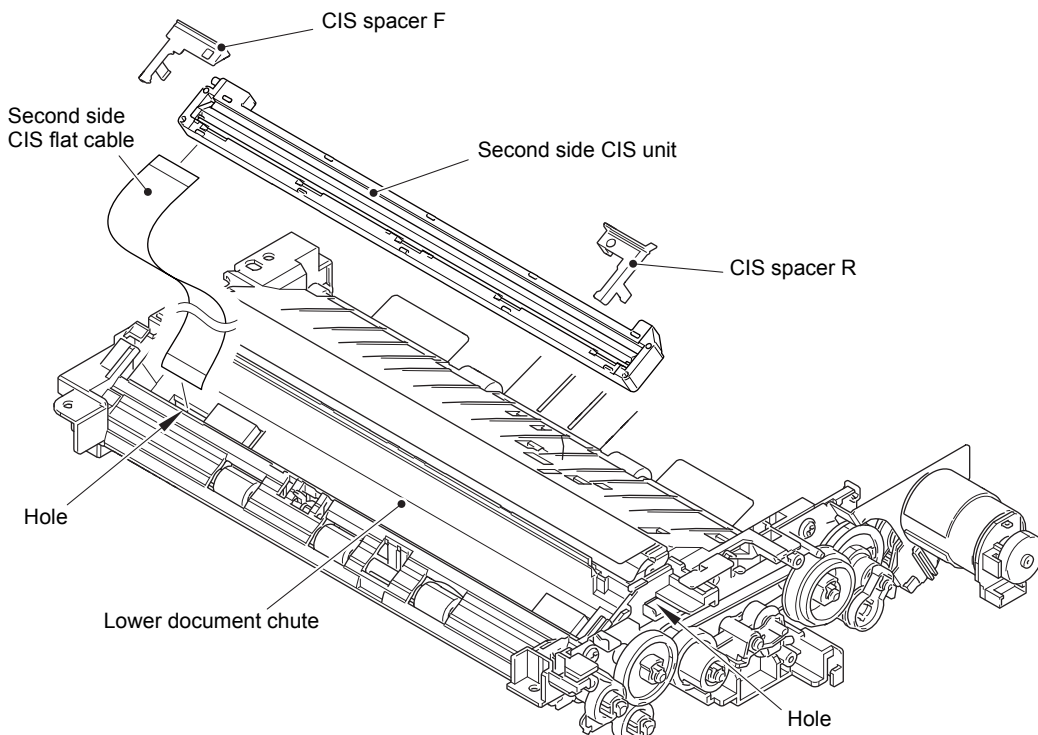

Fig. 3-45

Assembling Note:

- Fold the second side CIS flat cable at the positions shown in the figure below.

■ **For A4**

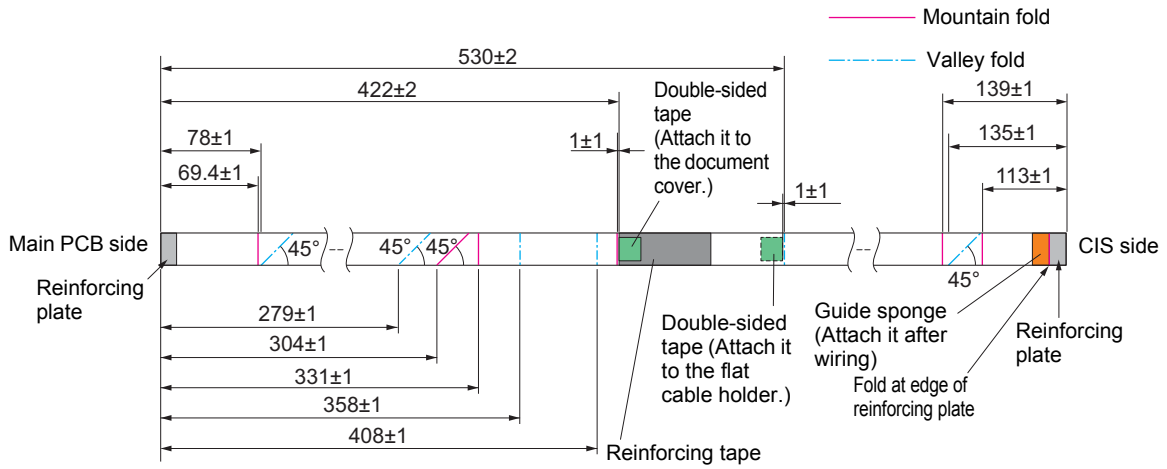

Fig. 3-46

■ **For LGL, Models without USB host on the rear side only**

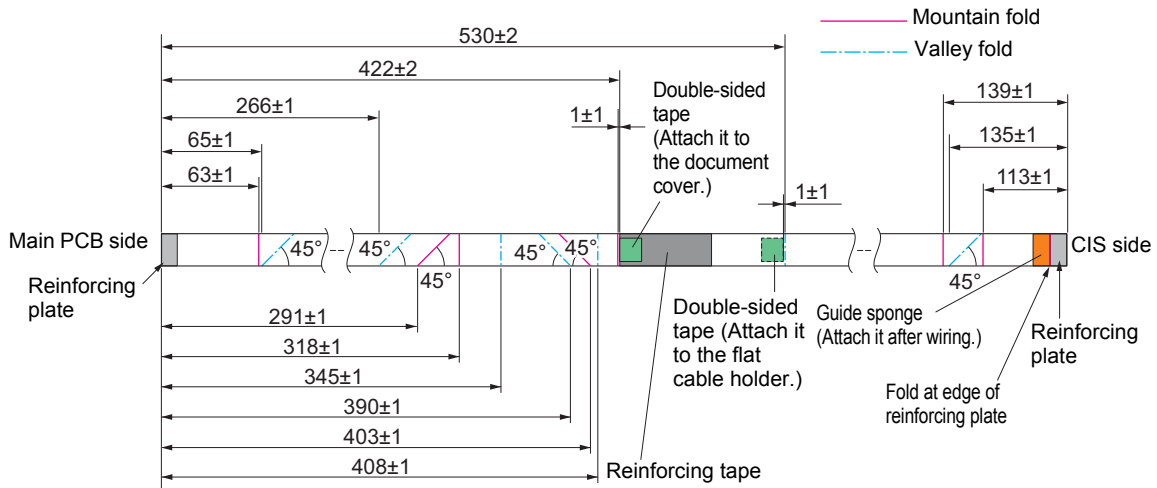

Fig. 3-47

■ **For LGL, Models with USB host on the rear side only**

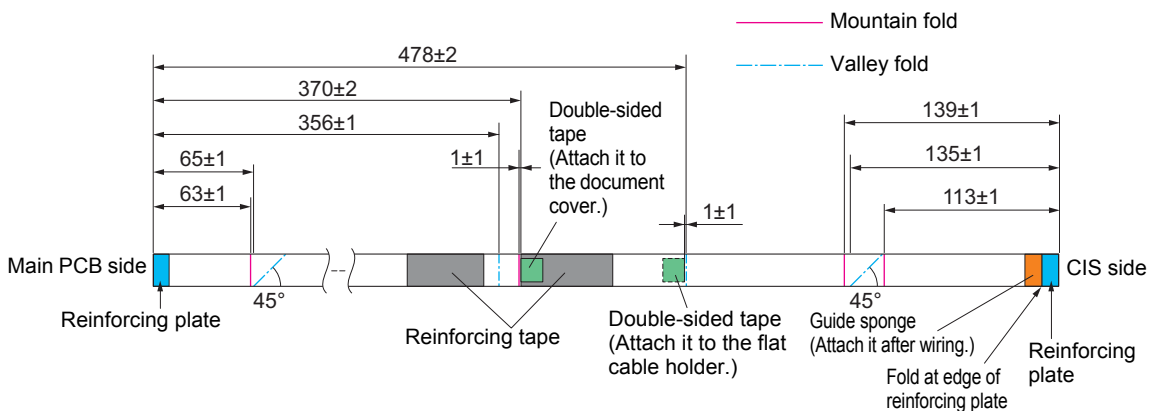

Fig. 3-48

Assembling Note:

- Attach the second side CIS flat cable to the document cover at the position shown in the following figure using a double-sided tape.

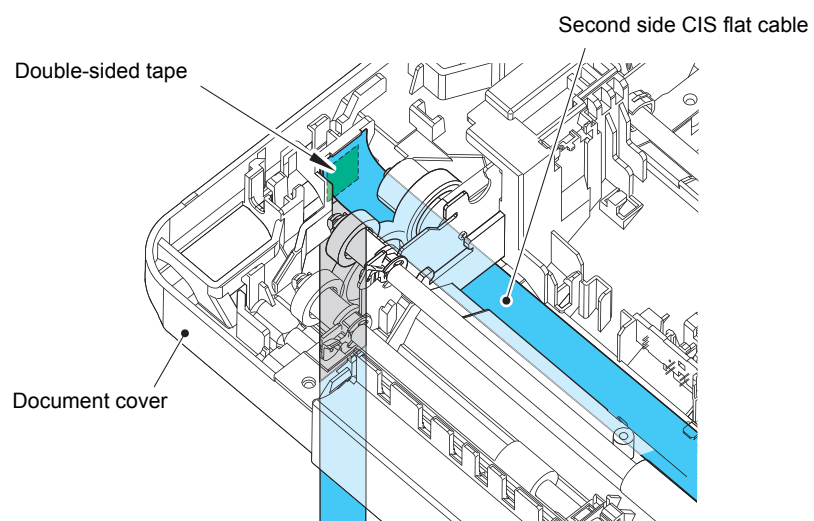

Fig. 3-49

9.12 Panel unit

9.12.1 Panel unit

- (1) Remove the four Taptite cup B M3x10 screws.
- (2) Release the three hooks to remove the panel unit. Disconnect the panel flat cable from the panel PCB ASSY.

Note:

- Flat cable is connected to the panel unit. Do not pull the panel unit too hard when removing it.

- (3) Release the panel flat cable from the securing fixtures.

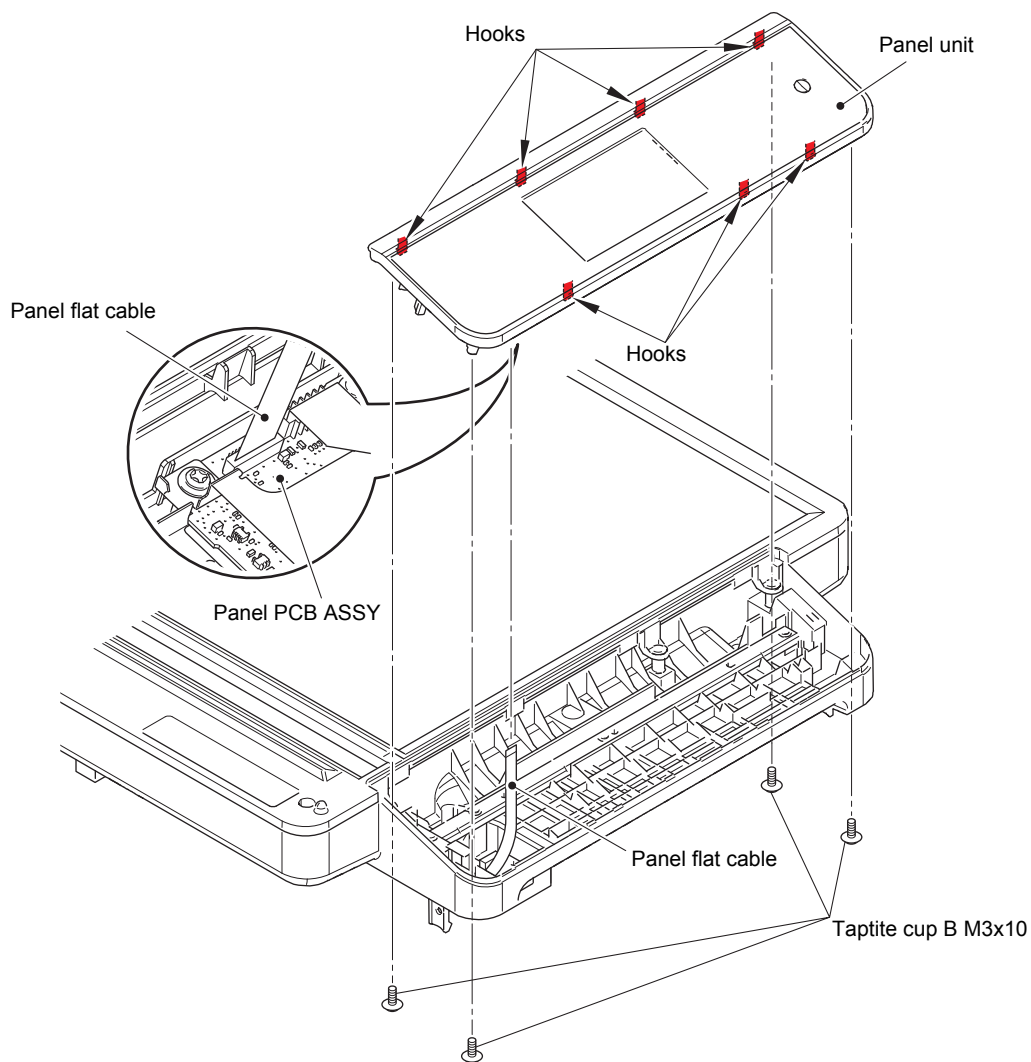

Fig. 3-50

Harness routing: Refer to “5. Document scanner unit”, “6. Panel unit (4.85 inch model)”.

Assembling Note:

- If you replaced the panel unit, refer to “4. IF YOU REPLACE THE LCD PANEL ASSY OR PANEL PCB” in chapter 4 and configure the setting.

Assembling Note:

- Fold the panel flat cable at the positions shown in the figure below.

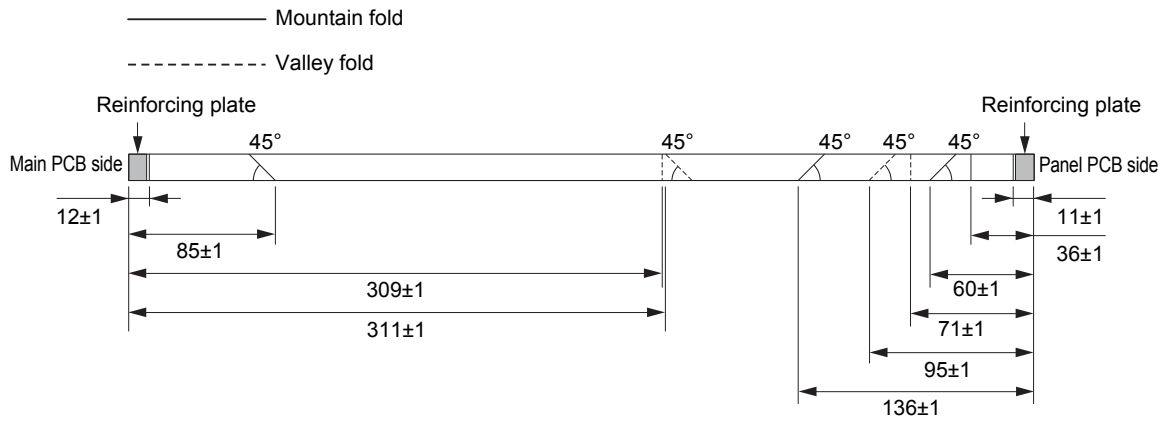

Fig. 3-51

9.12.2 Panel PCB ASSY, LCD (For LCD: 4.85 inch models)

- (1) Disconnect the key PCB flat cable from the panel PCB ASSY and release it from the securing fixtures.
- (2) Remove the three taptite cup B M3x10 screws. Release each hook to remove the LCD presser from the panel cover.
- (3) Remove the four taptite cup B M3x10 screws, and remove the shield plate cover from the panel cover.

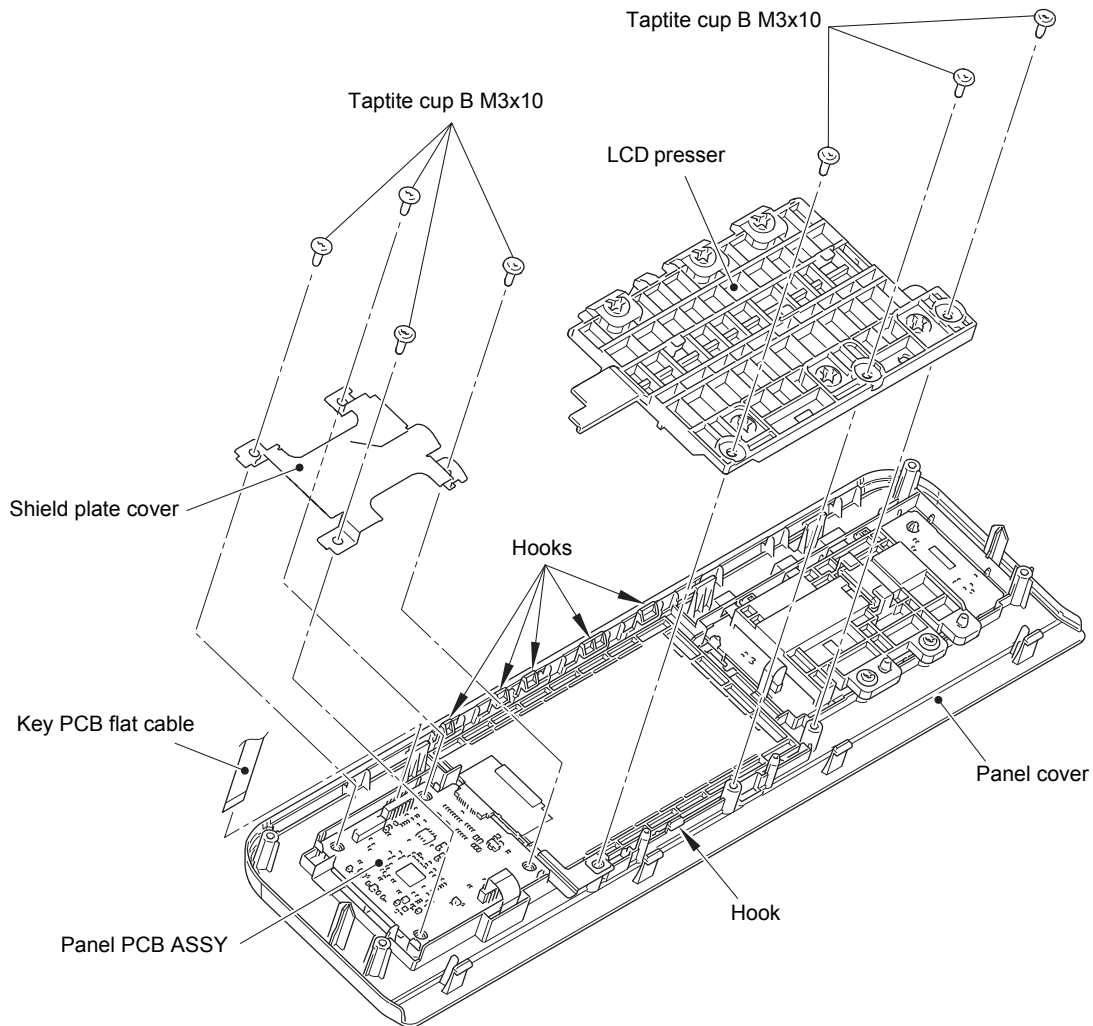

Fig. 3-52

Harness routing: Refer to "6. Panel unit (4.85 inch model)".

- (4) Disconnect the NFC flat cable from the panel PCB ASSY. (Models with NFC only)
- (5) Release the lock, and disconnect the LCD flat cable from the panel PCB ASSY.
- (6) Release the panel PCB ASSY and LCD from the panel unit.

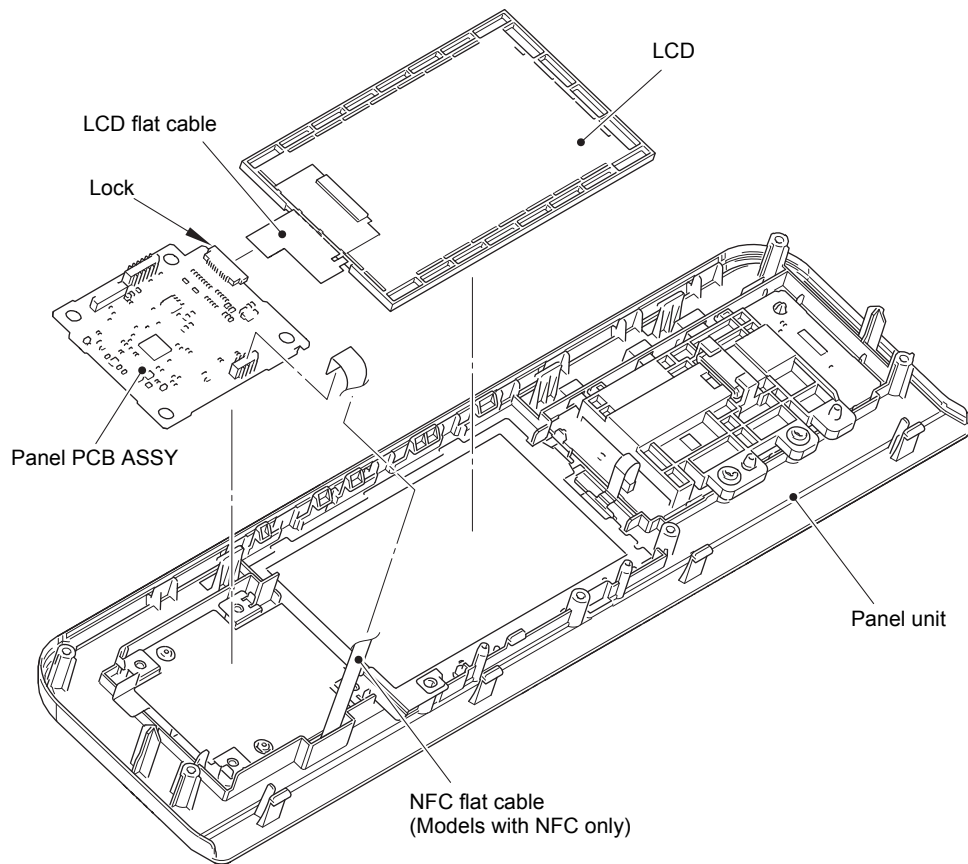

Fig. 3-53

9.12.3 Panel PCB ASSY, LCD, LCD relay PCB ASSY, LCD relay flat cable (For LCD: 3.7 inch models)

- (1) Disconnect the key PCB flat cable from the panel PCB ASSY and release it from the securing fixtures.
- (2) Peel the film. Unlock the lock to disconnect the LCD relay flat cable from the panel PCB ASSY.
- (3) Remove the three taptite cup B M3x10 screws. Release each hook to remove the LCD presser and LCD from the panel cover.
- (4) Remove the four taptite cup B M3x10 screws, and remove the shield plate cover and panel PCB ASSY from the panel cover.

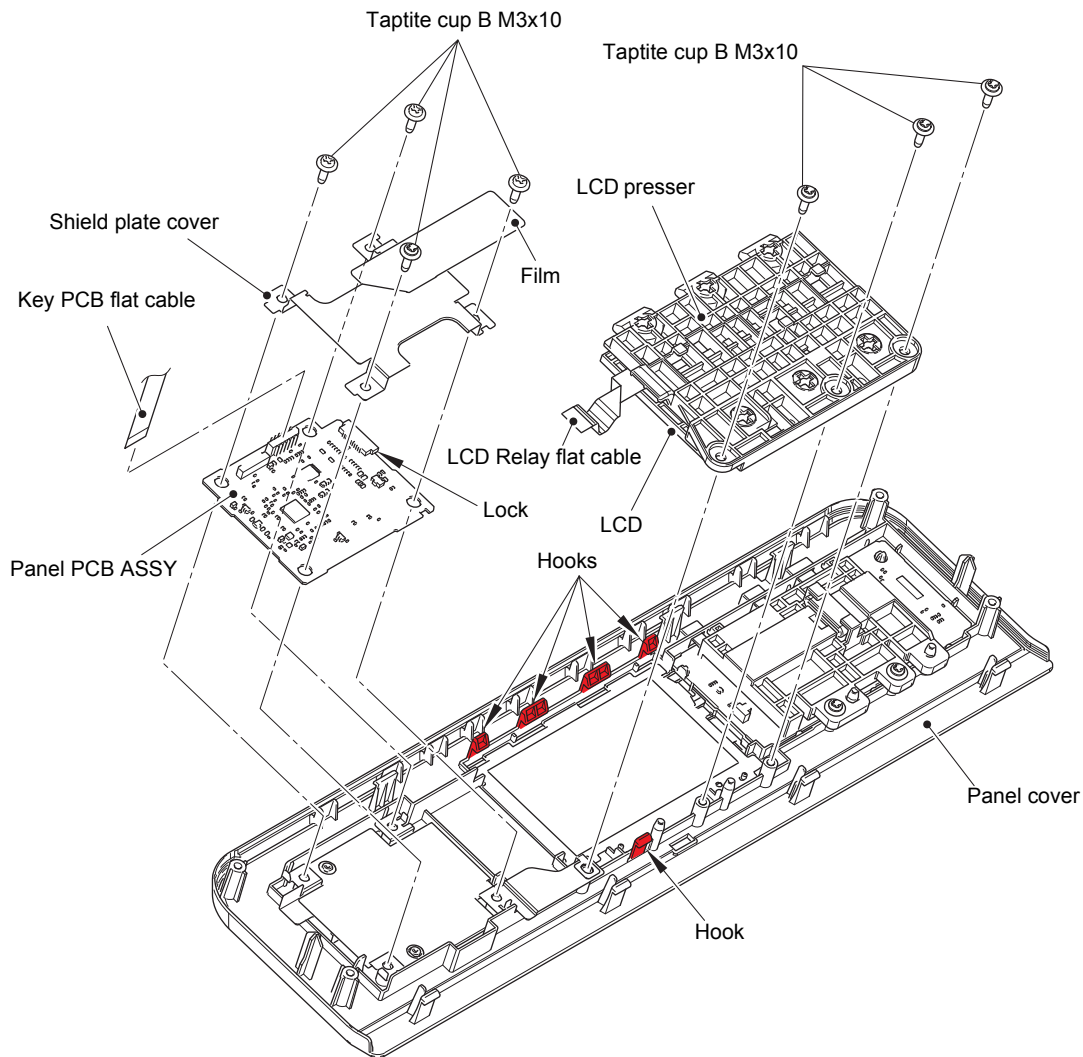

Fig. 3-54

Harness routing: Refer to "7. Panel unit (3.7 inch model)".

- (5) Unlock the lock to disconnect the LCD flat cable from the relay PCB ASSY.
- (6) Unlock the lock to disconnect the LCD relay flat cable from the LCD relay PCB ASSY.
- (7) Release the hook, and remove the LCD relay PCB ASSY from the LCD presser.

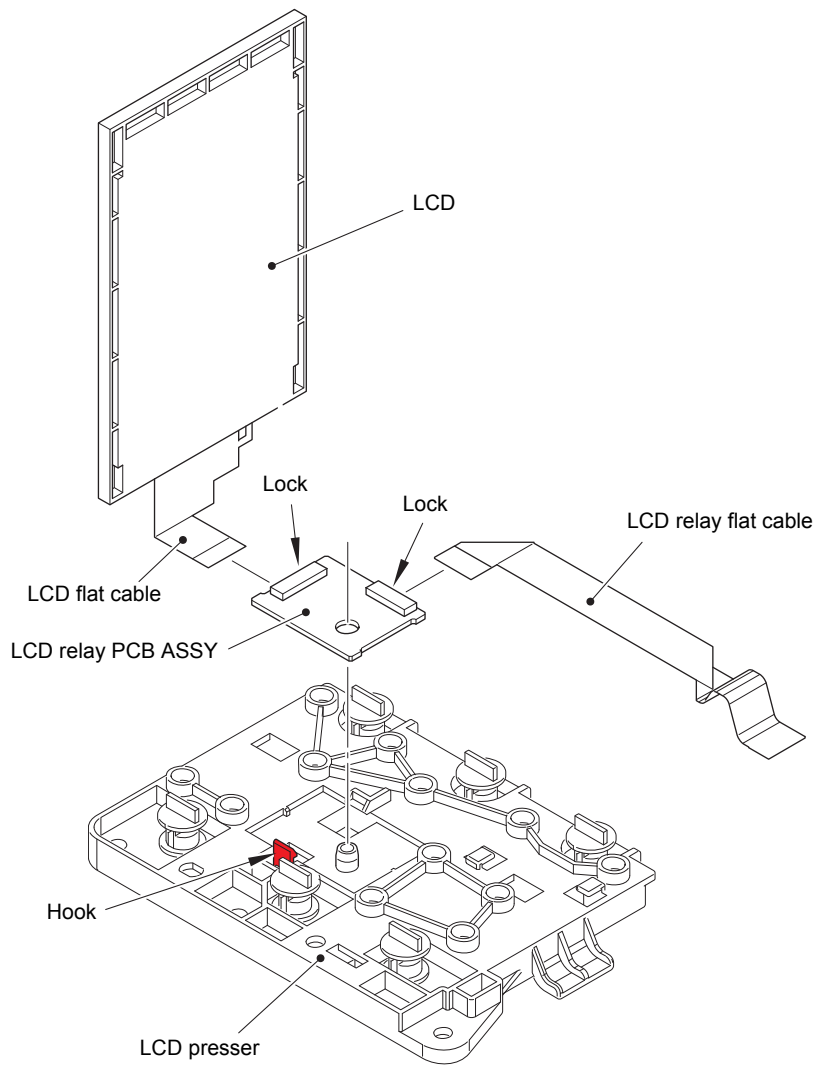

Fig. 3-55

Harness routing: Refer to [“7. Panel unit \(3.7 inch model\)”](#).

9.12.4 Touch panel ASSY

- (1) Disconnect the touch panel flat cable from the key PCB ASSY.
- (2) Remove the touch panel ASSY from the panel unit.

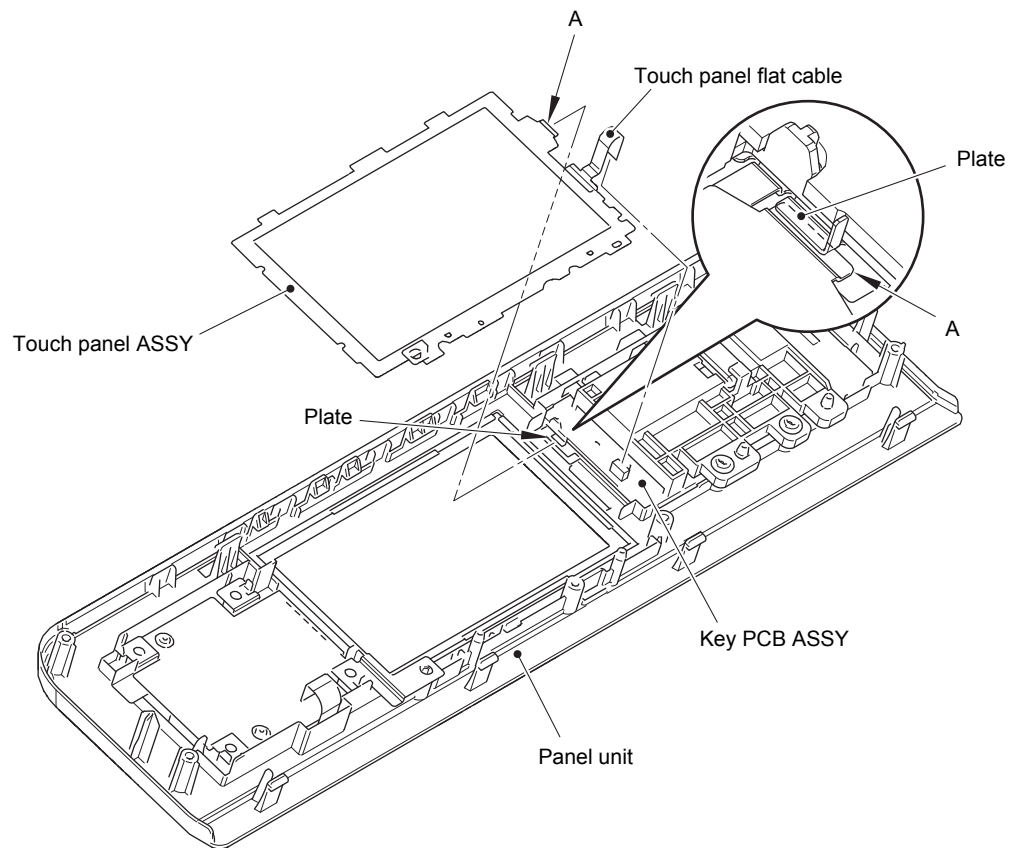

Fig. 3-56

Assembling Note:

- When assembling the touch panel ASSY, put the section A under the plate.
- If you replaced the touch panel ASSY, refer to **"4. IF YOU REPLACE THE LCD PANEL ASSY OR PANEL PCB"** in chapter 4 and configure the setting.

9.12.5 NFC PCB ASSY (Models with NFC only)

- (1) Remove the shield plate base / protection film from the panel unit.
- (2) Release the hook to remove the NFC PCB ASSY from the panel unit.

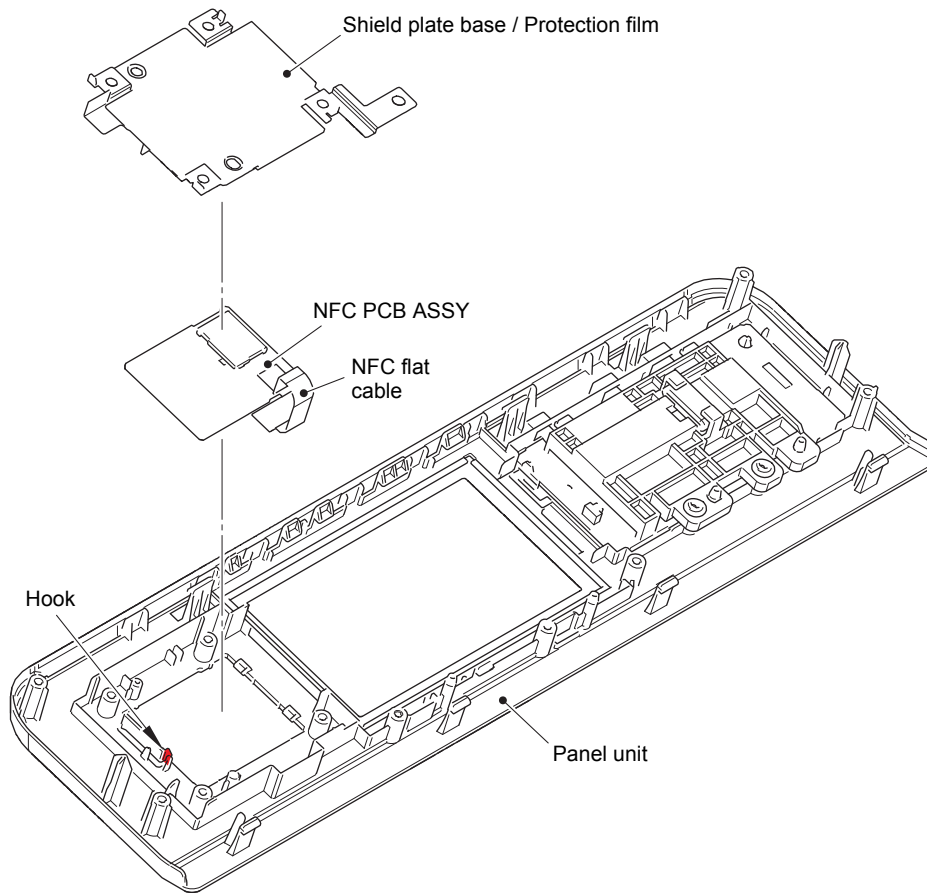

Fig. 3-57

Harness routing: Refer to "7. Panel unit (3.7 inch model)".

Assembling Note:

- Fold the NFC flat cable at the positions shown in the figure below.

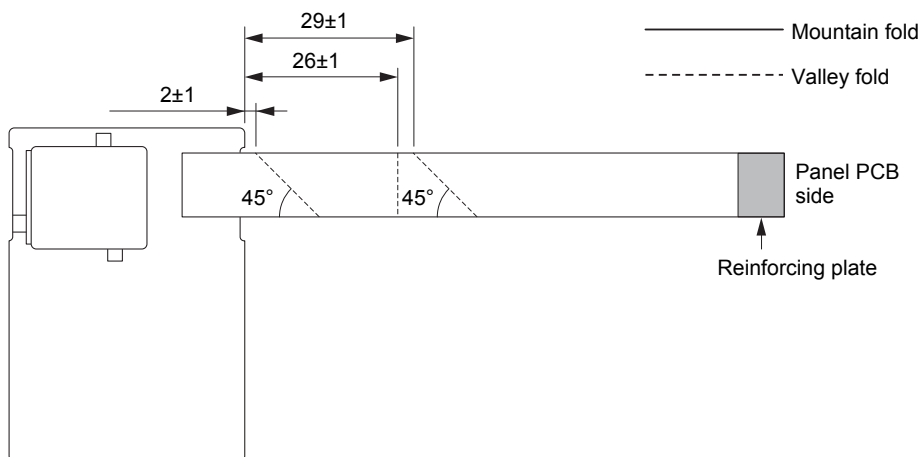

Fig. 3-58

9.13 USB host PCB ASSY

- (1) Remove the USB protection sheet.
- (2) Remove the two taptite bind B M4x12 screws to remove the USB host PCB ASSY from the document scanner unit. Disconnect the USB host harness from the USB host PCB ASSY.

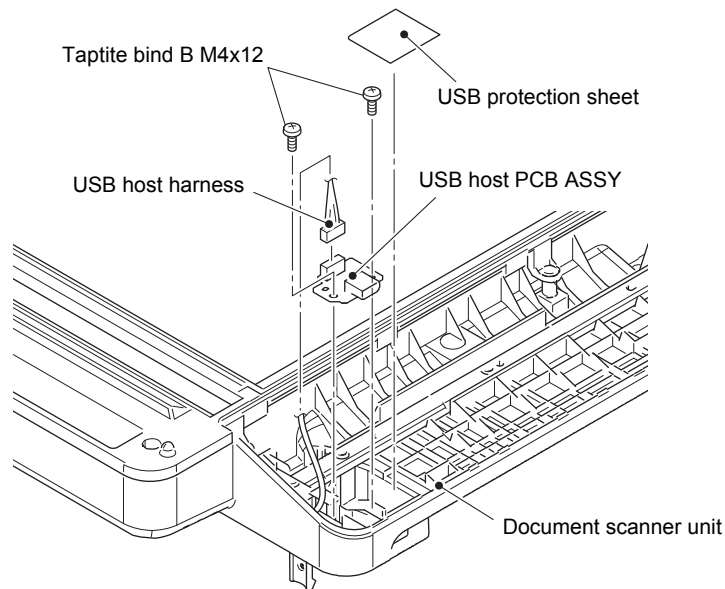

Fig. 3-59

Harness routing: Refer to [“5. Document scanner unit”](#).

Assembling Note:

- Attach the USB protection sheet at the position shown in the illustration below.

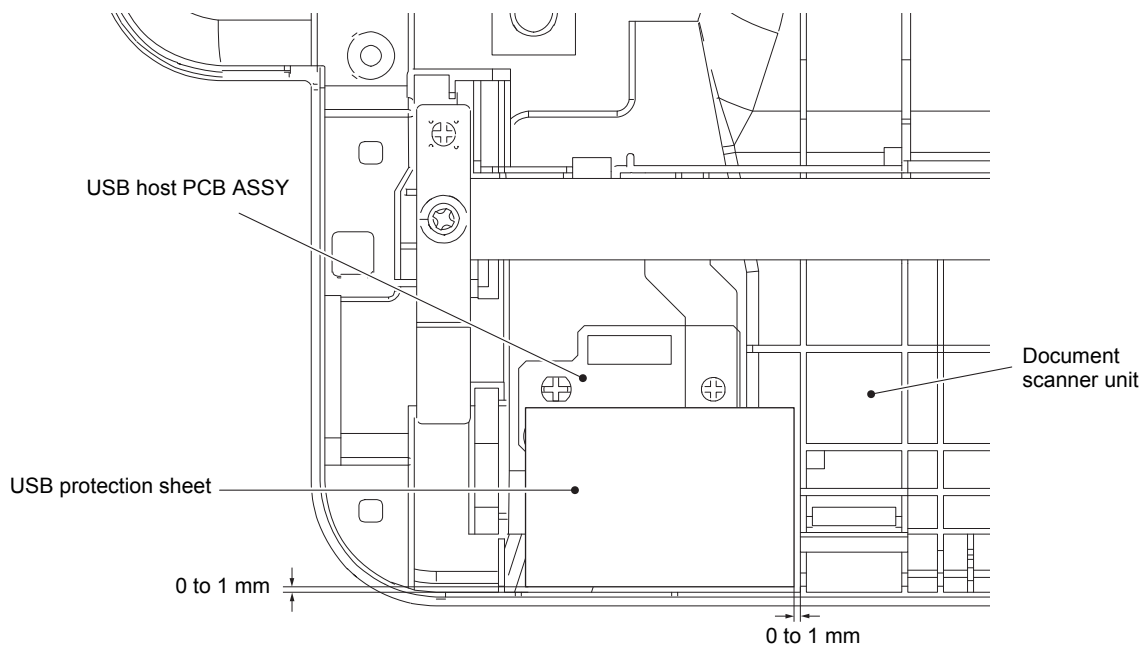

Fig. 3-60

9.14 First side CIS unit, First side CIS flat cable

Note:

- Replace the CIS unit in the clean place with no dust.

- (1) Remove the eight taptite bind B M4x12 screws.
- (2) Remove the scanner top cover from the document scanner unit.
- (3) Remove the CIS roller holder L ASSY and CIS roller holder R ASSY from the first side CIS unit.

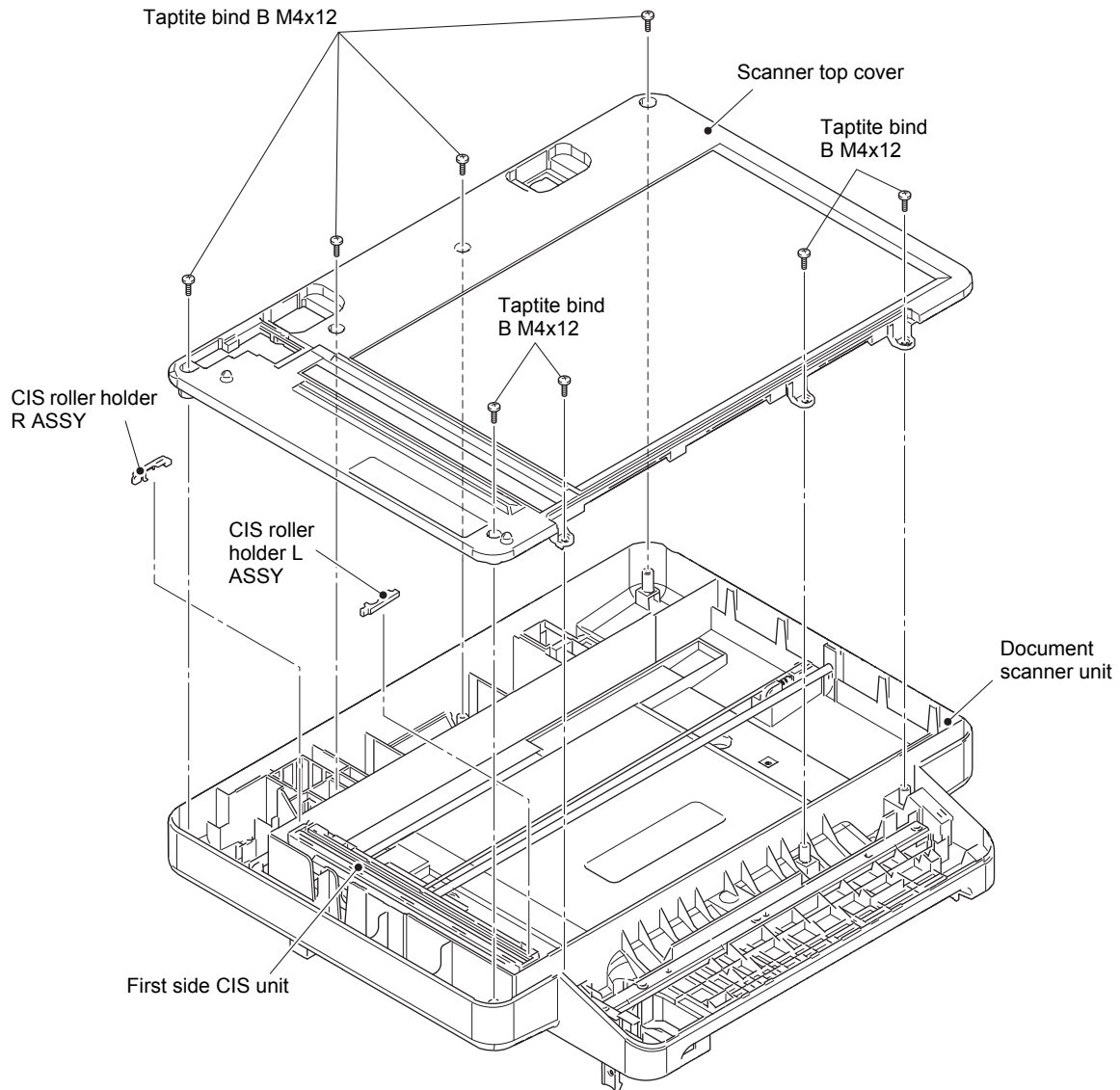

Fig. 3-61

- (4) Slide the CIS carriage slowly to the position described below.
- (5) Raise the first side CIS unit from the CIS carriage for 90 degrees. Slide the first side CIS unit in the direction of the arrow and release the boss to remove it. Disconnect the first side CIS flat cable from the first side CIS unit.

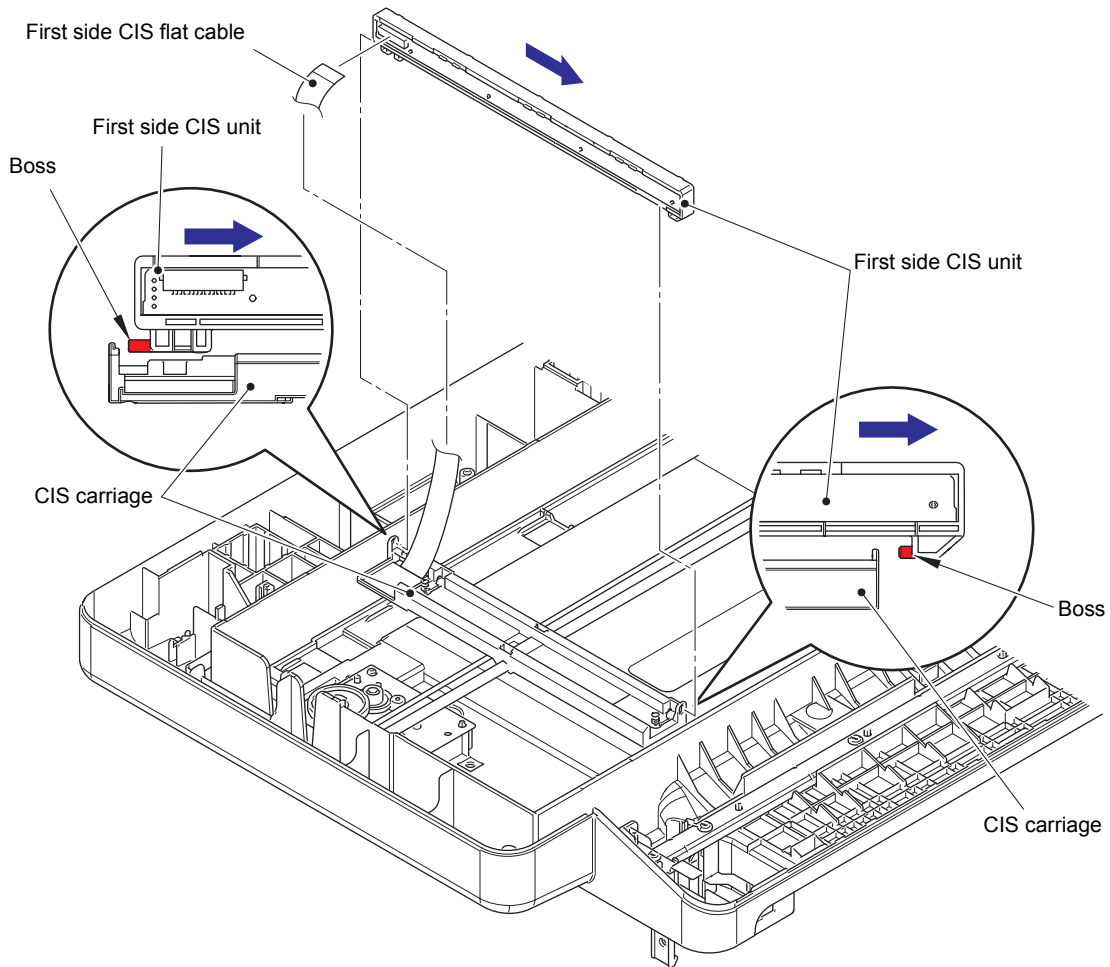

Fig. 3-62

Harness routing: Refer to "5. Document scanner unit".

Assembling Note:

- If you replaced the first side CIS unit, refer to "5. IF YOU REPLACE THE ADF UNIT, FIRST SIDE CIS UNIT, SECOND SIDE CIS UNIT OR DOCUMENT SCANNER UNIT" in chapter 4 and configure the setting.

(6) Remove the CIS carriage from the CIS drive belt.

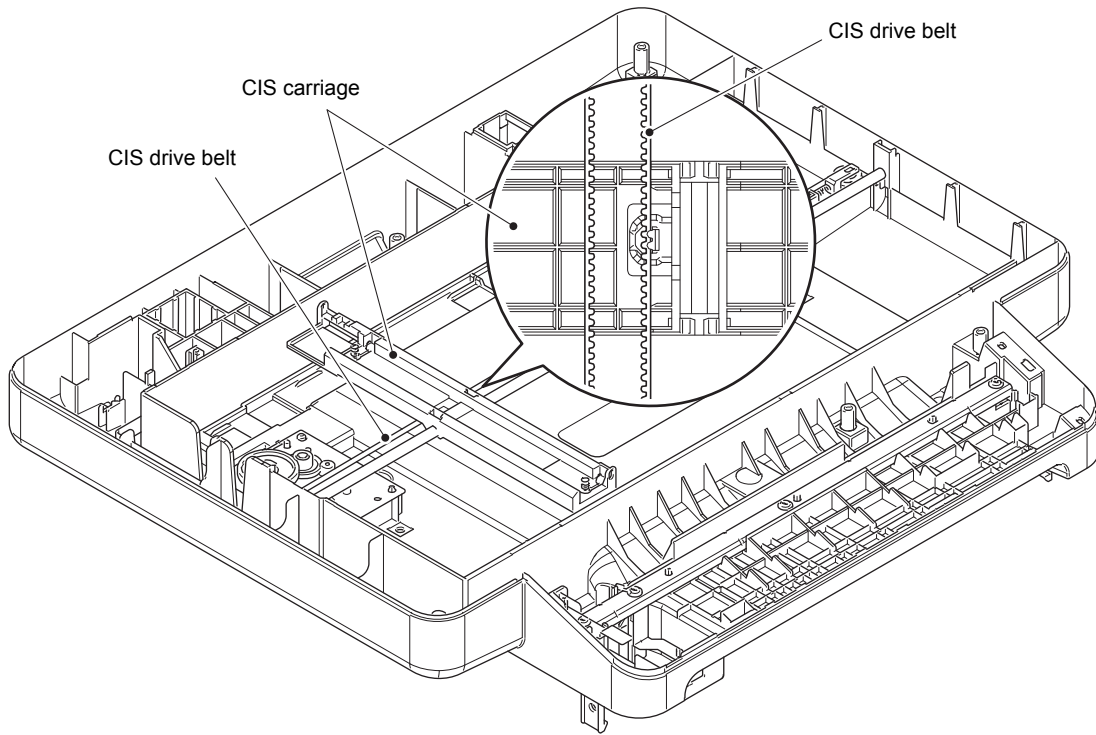

Fig. 3-63

(7) Remove the first side CIS flat cable behind the CIS carriage from the double-sided tape.

Note:

- Once the double-sided tape is removed from the first side CIS flat cable, replace it with a new one.

(8) Remove the first side CIS flat cable from the document scanner unit.

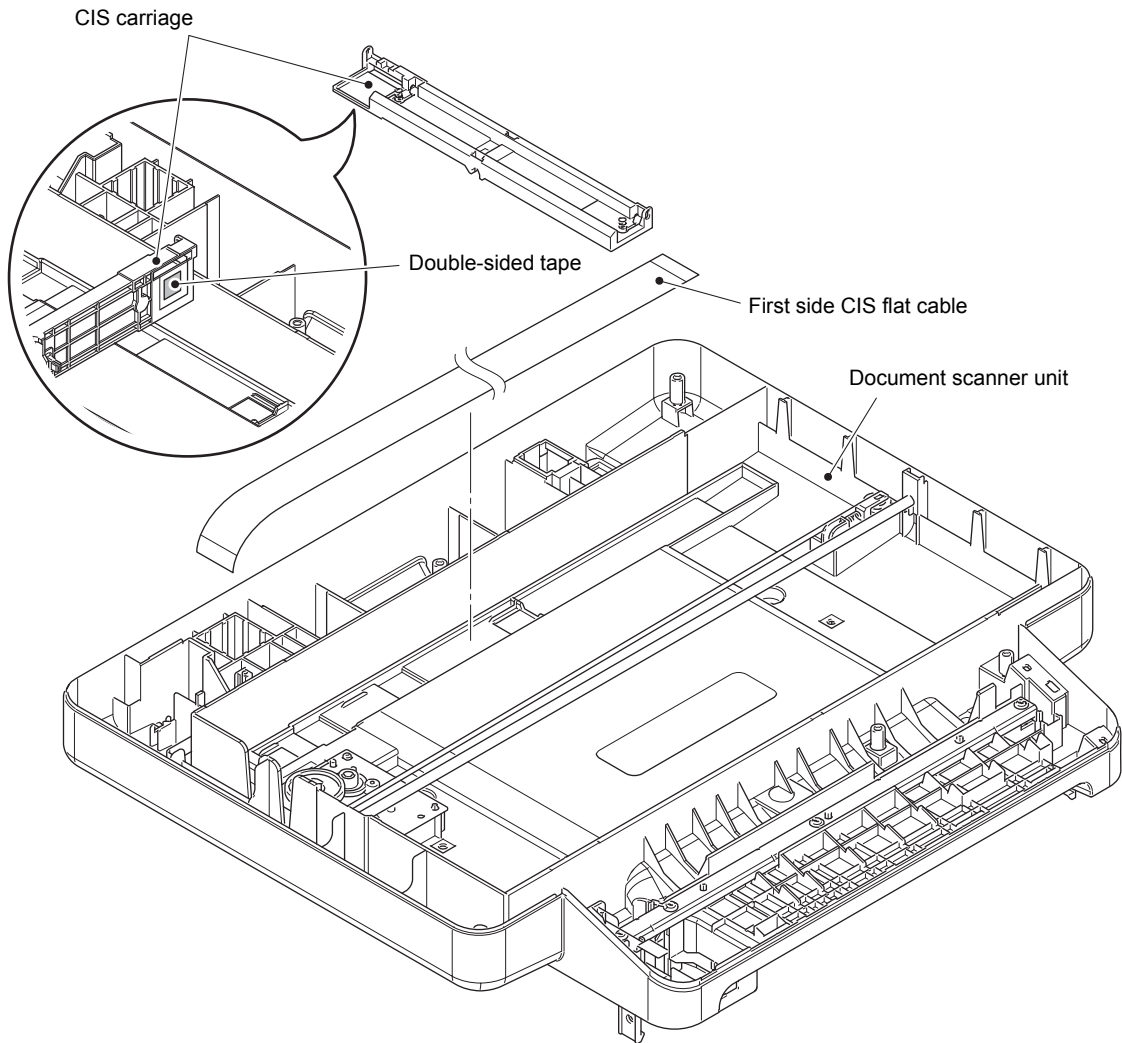

Fig. 3-64

Harness routing: Refer to [“5. Document scanner unit”](#).

< Attachment Procedure >

1) Fold the first side CIS flat cable as shown in the illustration below.

■ For A4

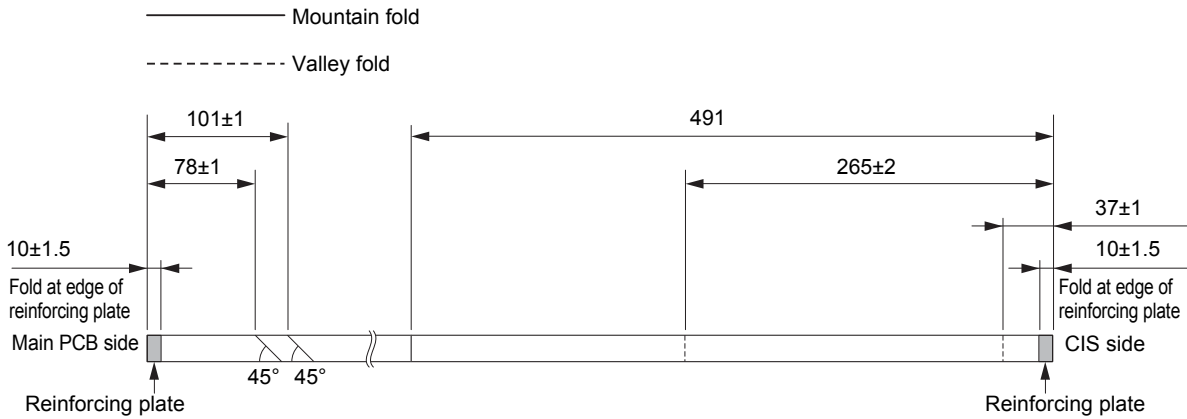

Fig. 3-65

■ For LGL

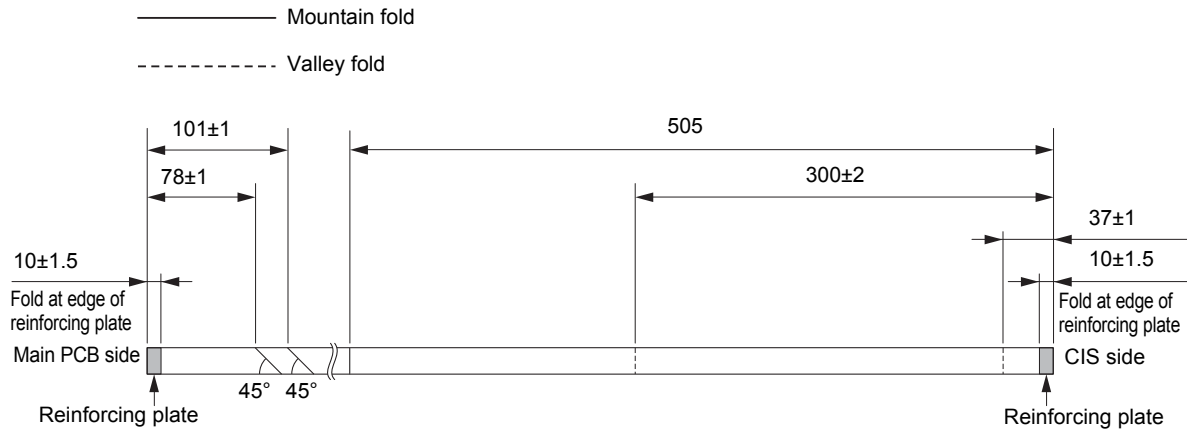

Fig. 3-66

2) Attach the two pieces of 12 mm x 12 mm double-sided tape on the document scanner unit at positions shown in the illustration below. (If the old double-sided tape remains attached, replace it with a new one.)

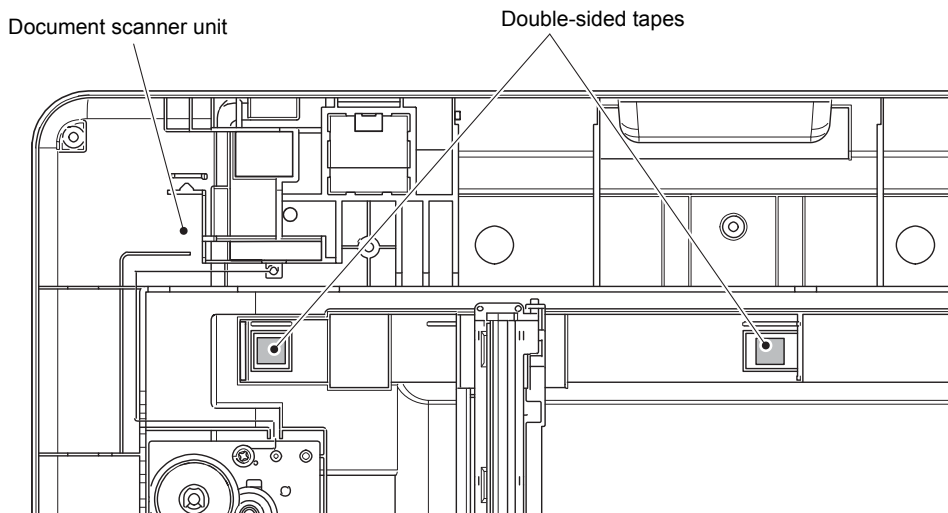

Fig. 3-67

- 3) Attach the 12 mm x 12 mm double-sided tape to the CIS carriage at the position shown in the illustration below. (If the old double-sided tape remains attached, replace it with a new one.)
- 4) Connect the first side CIS flat cable to the first side CIS unit.
- 5) Attach the first side CIS unit to the CIS carriage.
- 6) Peel the release liner of the double-sided tape attached to the CIS carriage, and secure the first side CIS flat cable with the tape as shown in the illustration below.

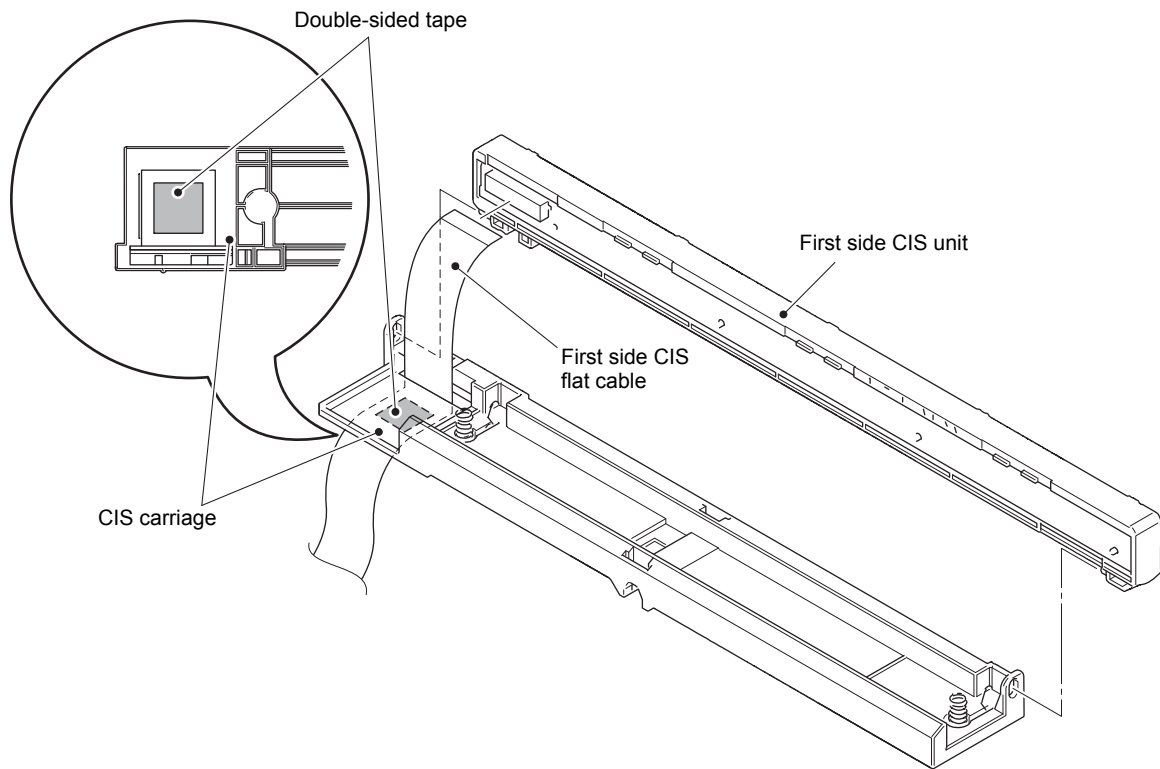

Fig. 3-68

- 7) Pass the first side CIS flat cable through the flat core.
- 8) Peel the release liner of the two pieces of double-sided tape attached to the document scanner unit, and secure the first side CIS flat cable with the tape as shown in the illustration below.

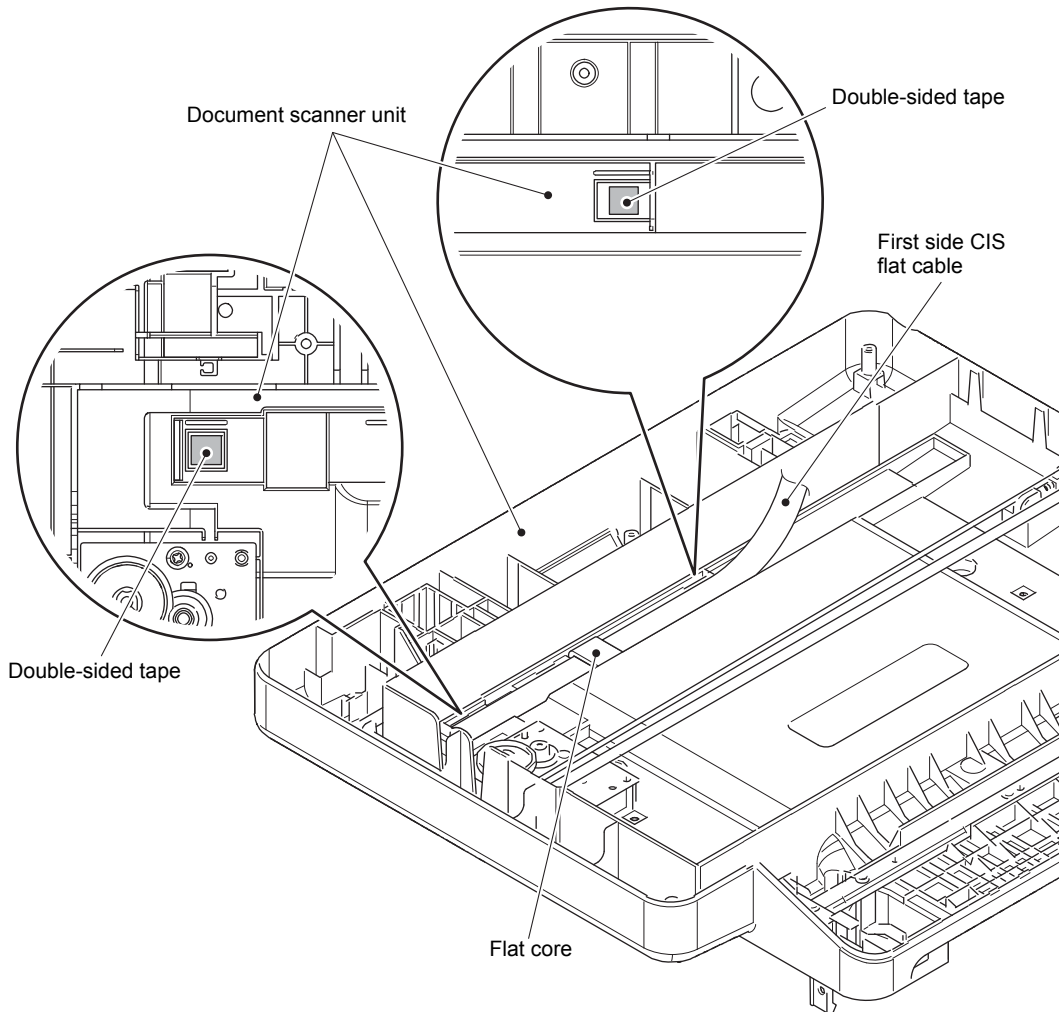
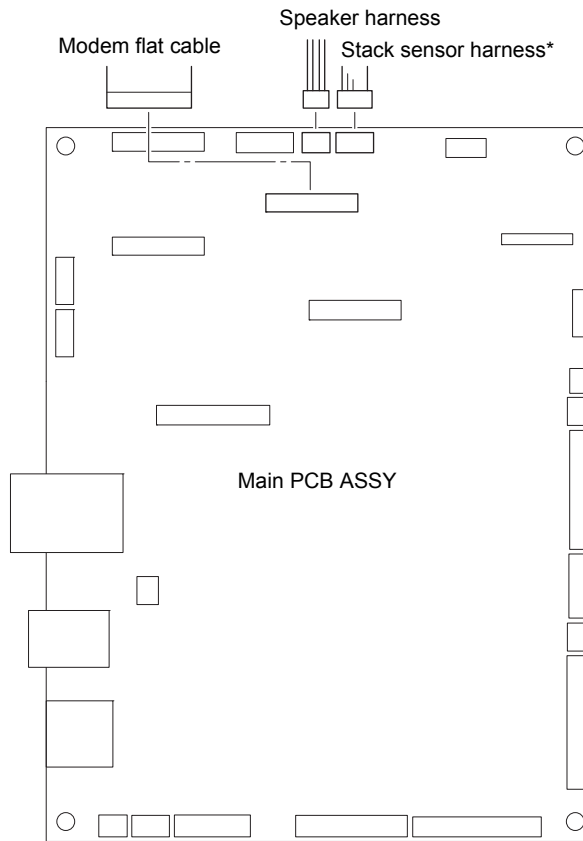

Fig. 3-69

Harness routing: Refer to **“5. Document scanner unit”**.

9.15 Joint cover ASSY

- (1) Disconnect the modem flat cable, speaker harness, and stack sensor harness* from the main PCB ASSY.



* Models with USB host on the rear side only

Fig. 3-70

Harness routing: Refer to [“3. Left side of the machine”](#), [“10. Left side of the machine”](#).

- (2) Remove the taprite cup S M3x8 SR screw to remove the modem FG harness R. Release the modem FG harness R from the securing fixtures of the hold cover 1.
- (3) Remove the six taprite bind B M4x12 screws. Release each hook to remove the joint cover ASSY.

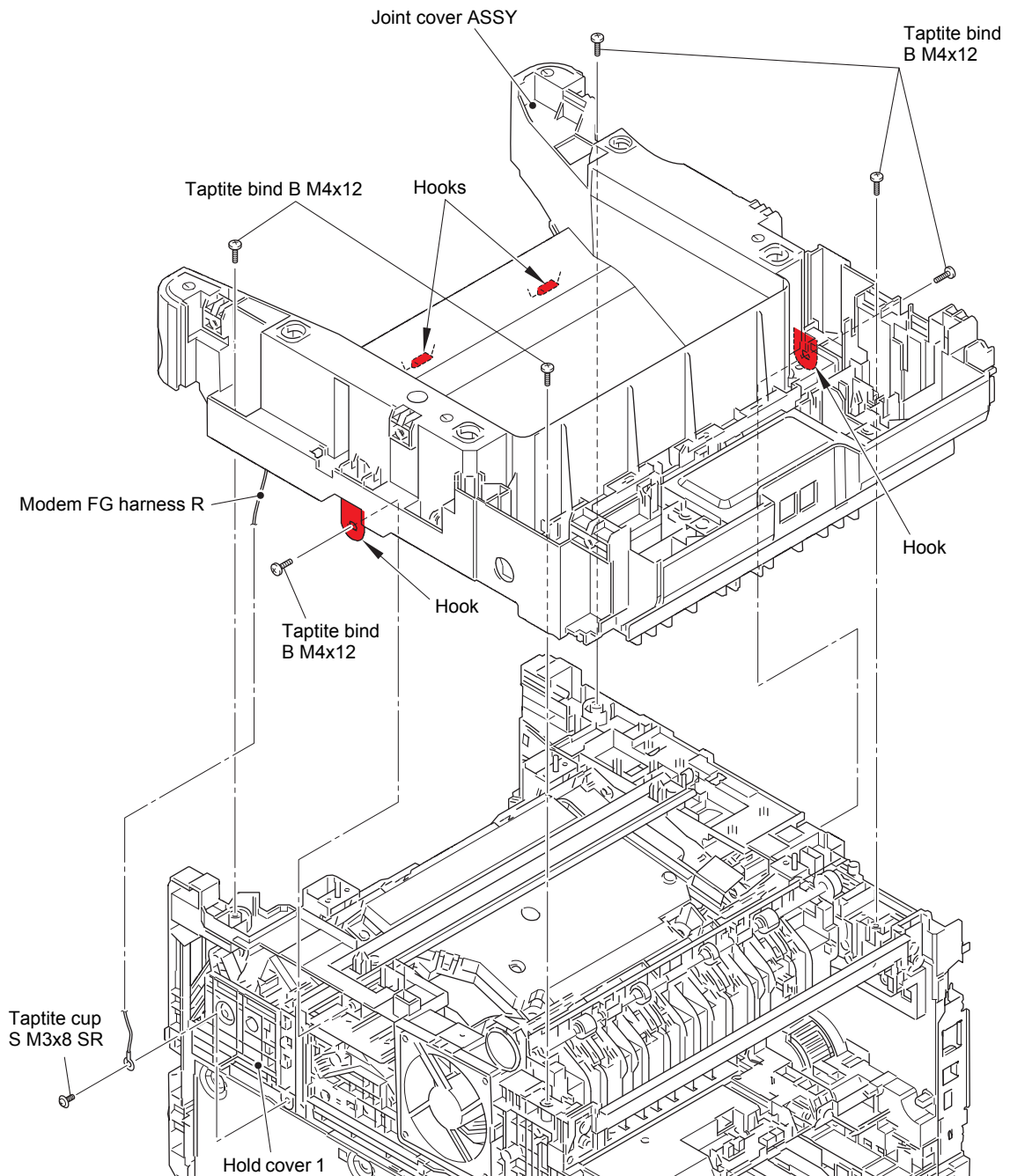

Fig. 3-71

Harness routing: Refer to [“9. Speaker unit, Modem \(LVPS side\)”](#).

Assembling Note:

- When assembling the joint cover ASSY, be careful not to damage the wireless LAN PCB.

9.16 Modem PCB ASSY (Models with FAX only)

- (1) Remove the two screw pan (S/P washer) M3.5X6 screws to remove the modem FG harness L and the modem FG harness R. Release the modem FG harness L and the modem FG harness R from the securing fixtures.
- (2) Release the modem flat cable from the securing fixtures.
- (3) Remove the two taptite bind B M4x12 screws, and remove the modem shield plate from the joint cover ASSY.
- (4) Disconnect the modem flat cable from the modem PCB ASSY.
- (5) Remove the screw pan (S/P washer) M3.5X6 screw to remove the modem shield cover from the modem shield plate.
- (6) Remove the two taptite cup S M3x6 SR screws to remove the modem PCB ASSY from the modem shield plate.

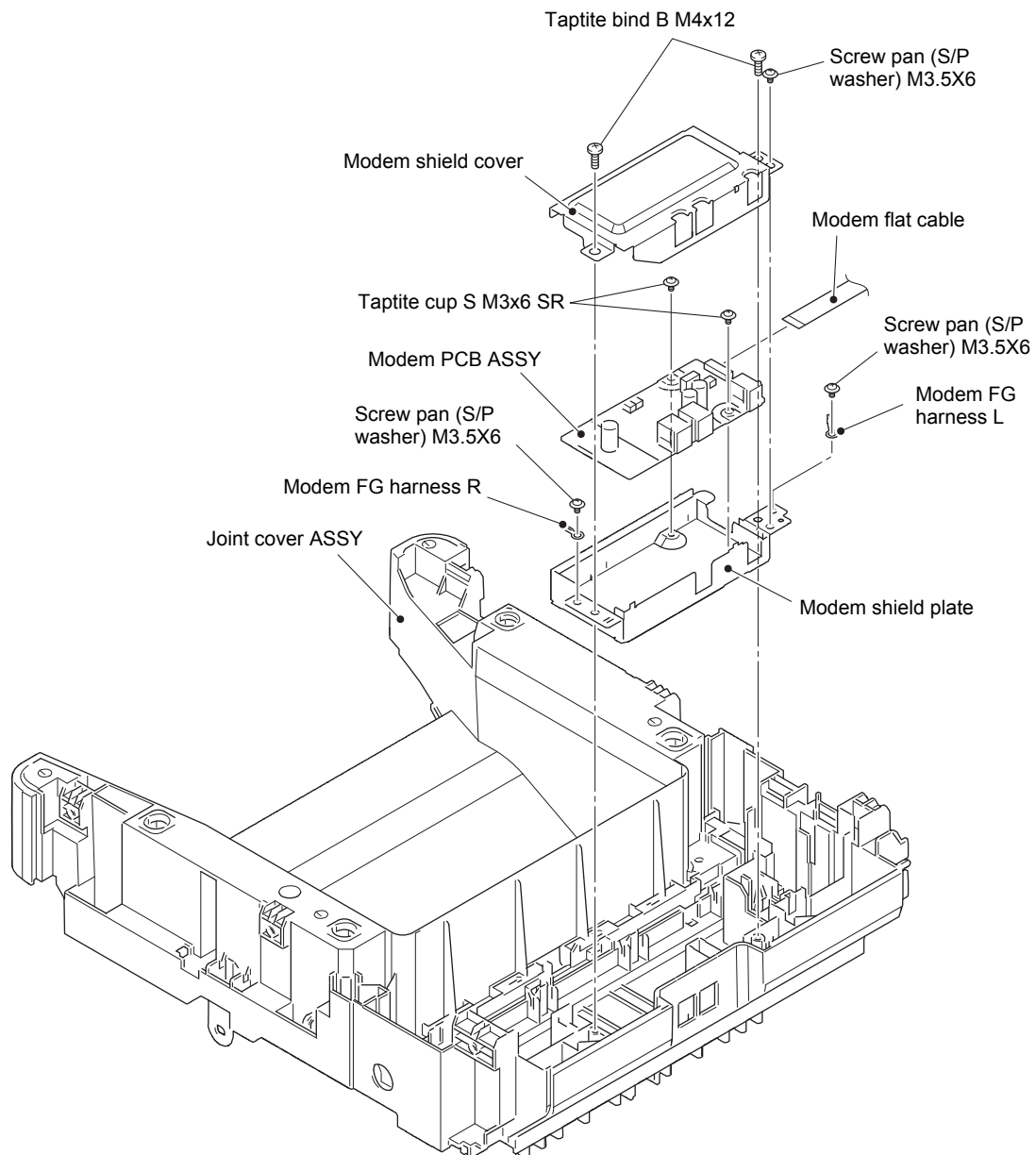

Fig. 3-72

Harness routing: Refer to "8. Speaker unit, Modem (Main PCB side)", "9. Speaker unit, Modem (LVPS side)".

Assembling Note:

- Fold the modem flat cable at the positions shown in the figure below.

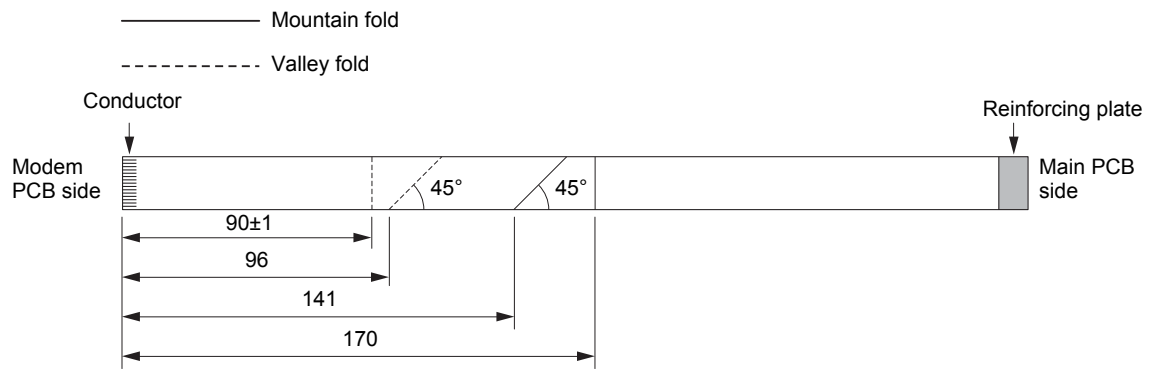

Fig. 3-73

9.17 Stack sensor PCB ASSY (Models with USB host on the rear side only)

- (1) Release the hook, and remove the stack sensor PCB ASSY from the joint cover ASSY. Release the stack sensor harness from the securing fixtures.

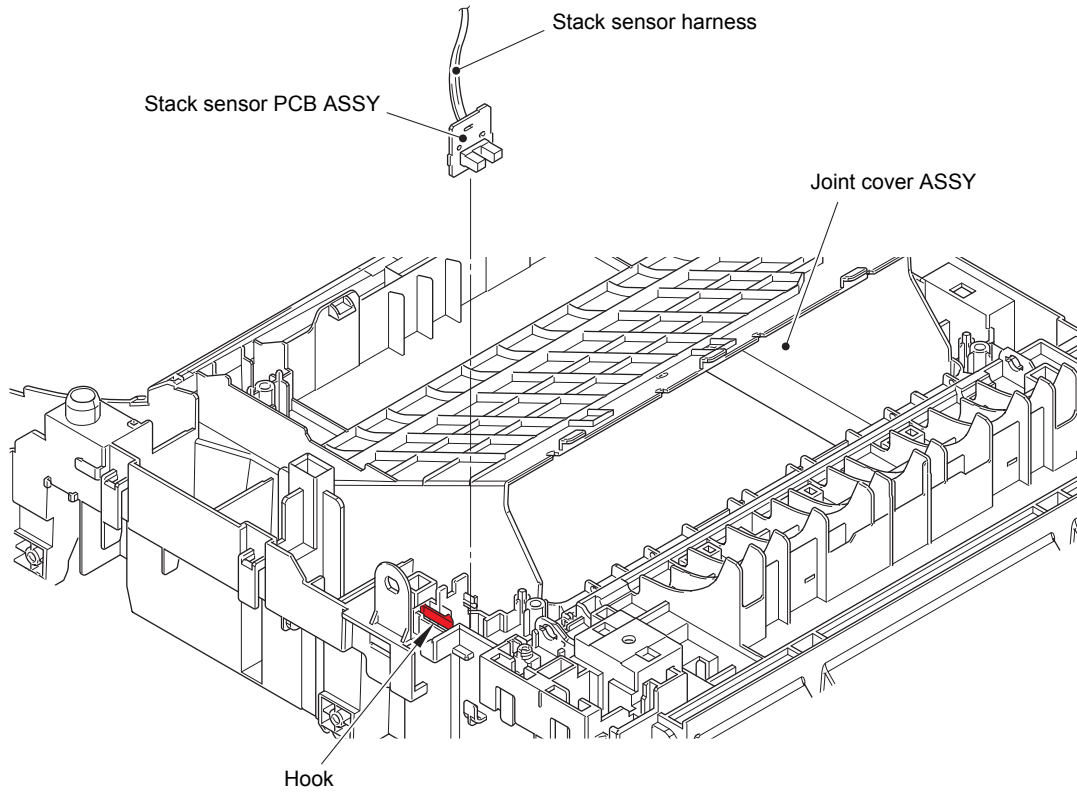

Fig. 3-74

Harness routing: Refer to ["9. Speaker unit, Modem \(LVPS side\)"](#).

9.18 Main PCB ASSY / Wireless LAN PCB (Wireless LAN models only)

- (1) Disconnect all harnesses and flat cables from the main PCB ASSY.
Release each harness and flat cable securing fixture from veil cover lower.

Note:

- After disconnecting flat cables, check that each cable is not damaged at its end or shortcircuited.
- When connecting flat cables, do not insert them at an angle. After insertion, check that the cable is not at an angle.

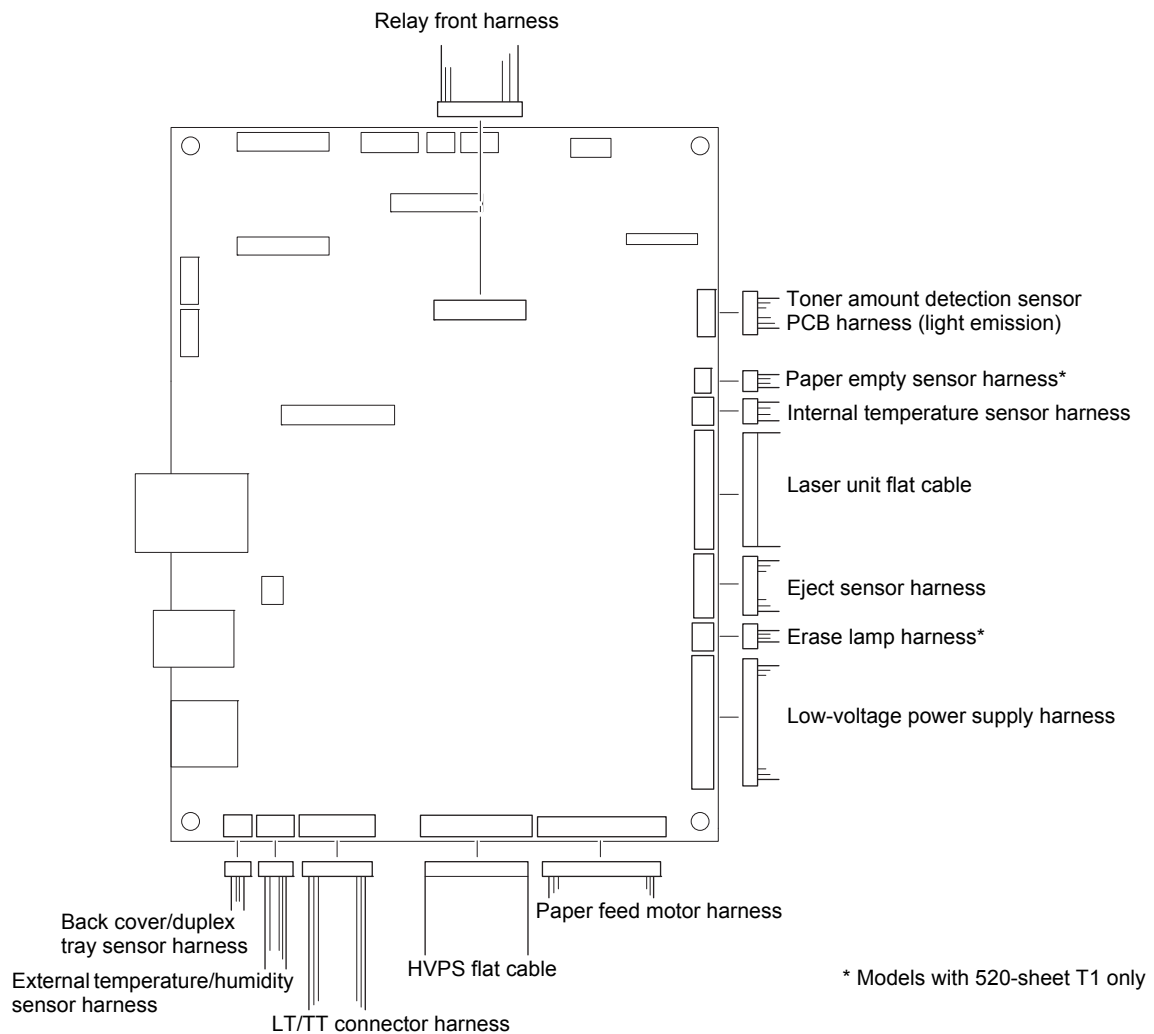

Fig. 3-75

Harness routing: Refer to "10. Left side of the machine".

- (2) Remove the tape, and disconnect the wireless LAN PCB. (Wireless LAN models only)
- (3) Remove the screw cup M3x8 (black) screw, and remove the veil cover lower.
- (4) Remove the four screw cup M3x8 (black) screws, and remove the main PCB ASSY.

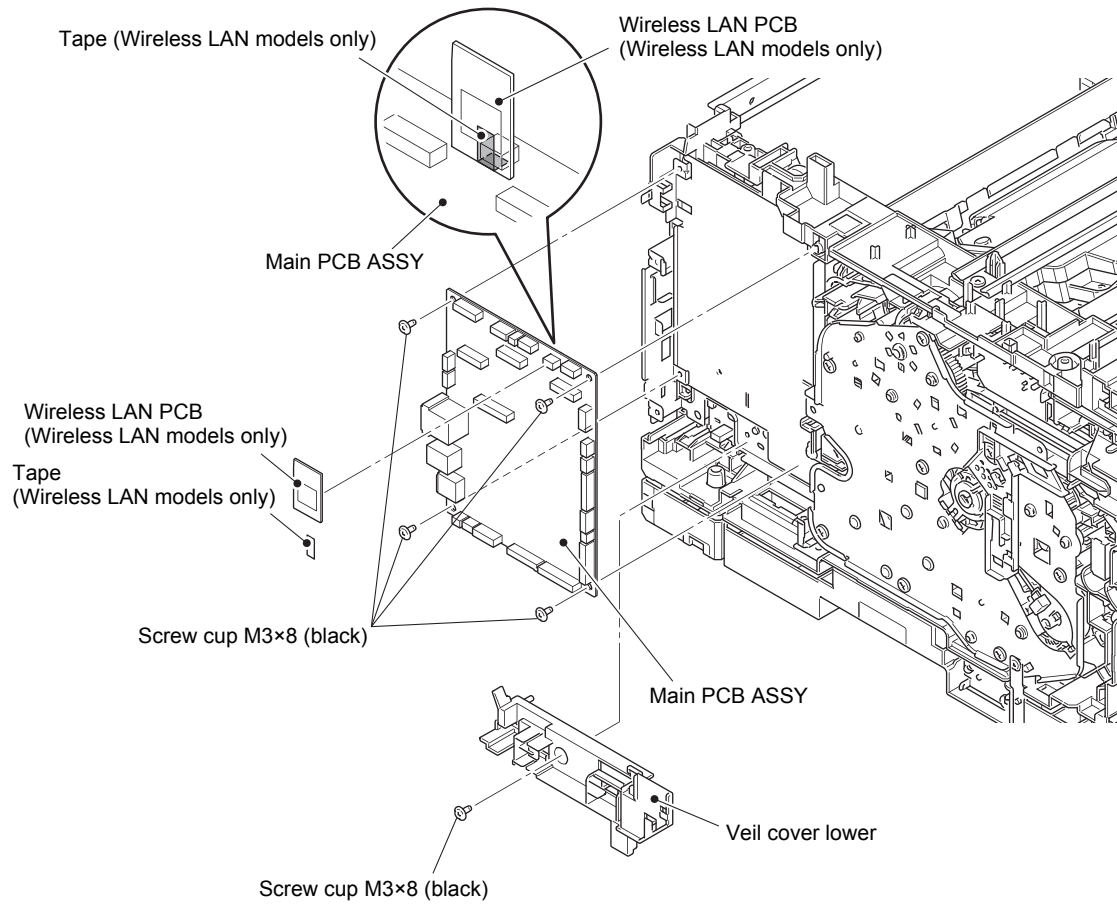

Fig. 3-76

Assembling Note:

- When connecting the wireless LAN PCB to the main PCB ASSY, secure it using tape as shown in the figure above.

9.19 External temperature/humidity sensor

(1) Release the hook, and remove the external temperature/humidity sensor.

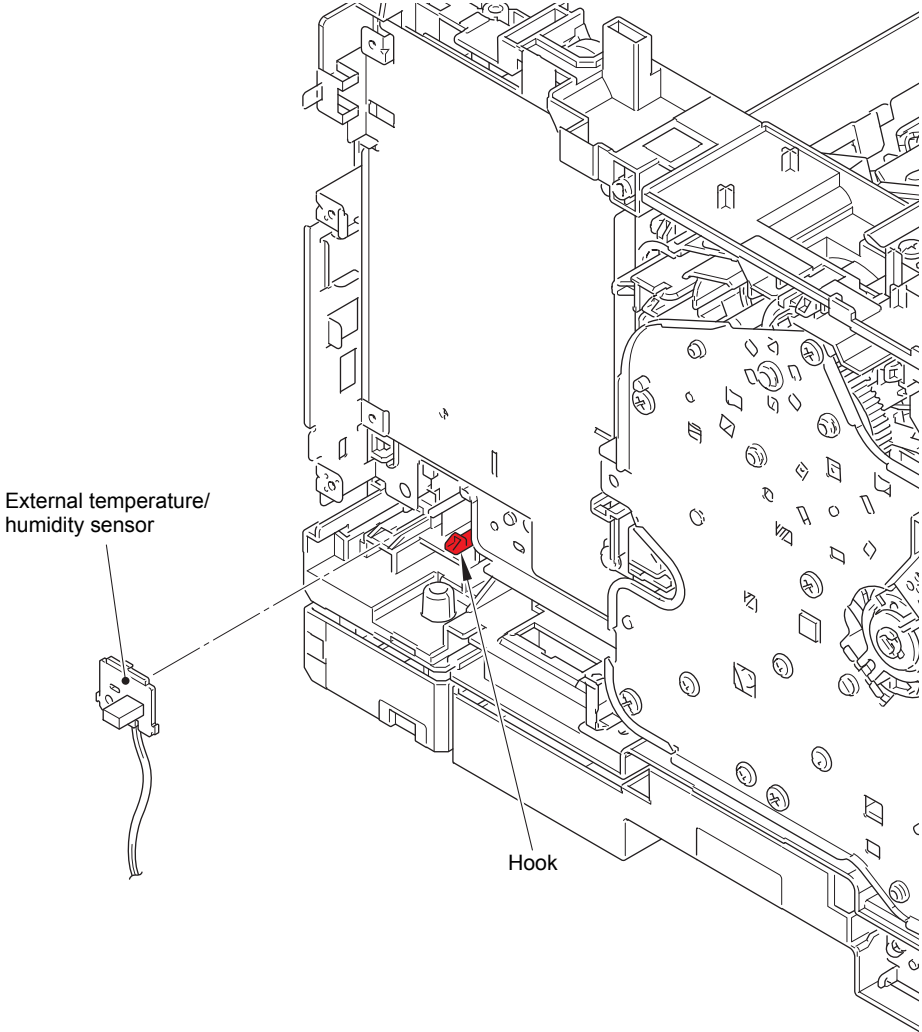

Fig. 3-77

9.20 Laser unit

- (1) Remove the two taptite bind B M4x12 screws, and remove the top bar. (Models with 520-sheet T1 only)
- (2) Disconnect the laser unit flat cable from the laser unit, and release it from the securing fixtures.
- (3) Remove the four taptite cup S M3x8 SR screws, and remove the laser unit.

Note:

- Be careful not to touch the lens of the laser unit.

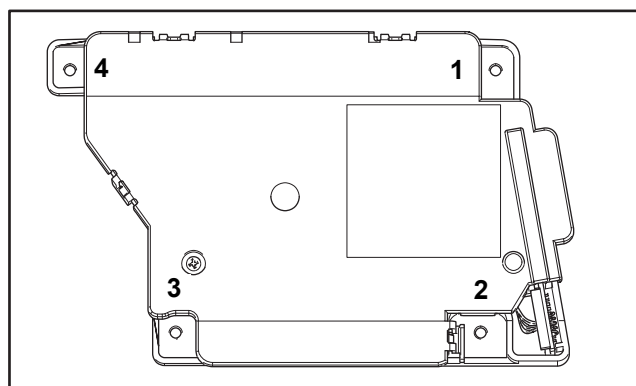
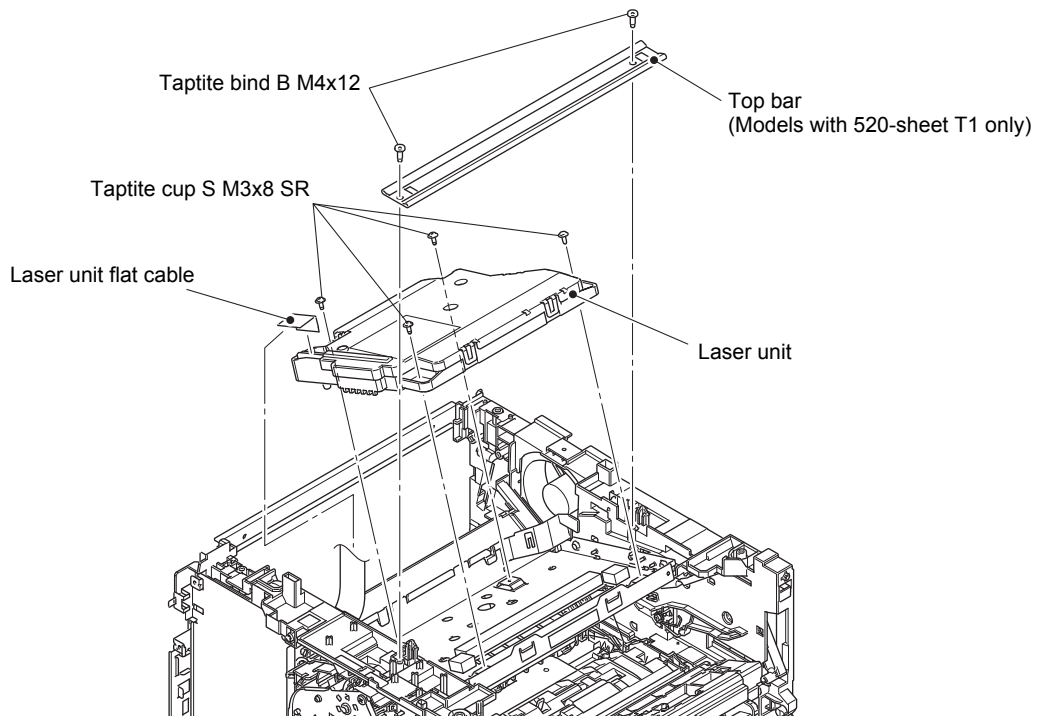

Fig. 3-78

Harness routing: Refer to “10. Left side of the machine”, “11. Rear side of the machine”.

Assembling Note:

- When attaching the laser unit, tighten the screws in the following order: upper right, lower right, lower left and upper left.
- When connecting flat cables, do not insert them at an angle. After insertion, check that the cable is not at an angle.

Assembling Note:

- Fold the laser unit flat cable at the positions shown in the figure below.

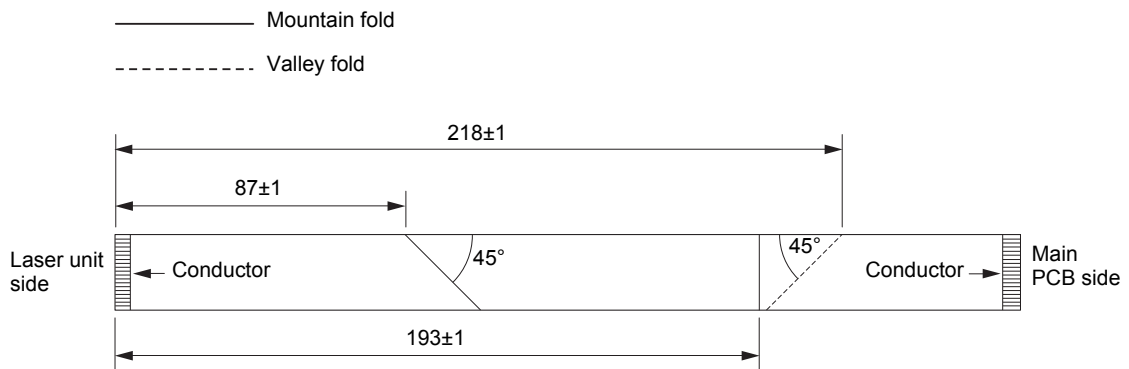

Fig. 3-79

< Location of the laser serial number on the laser unit >

Note:

- Attach the laser serial label to the position (on the laser plate) shown in the figure below after replacing the laser unit.

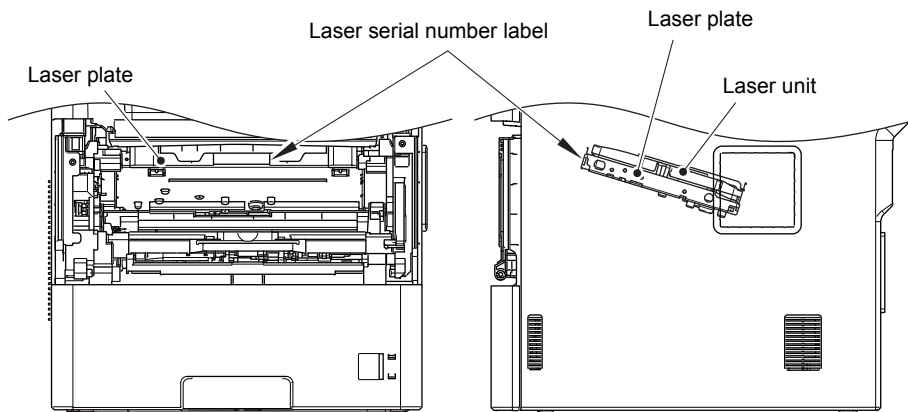

Fig. 3-80

9.21 PF roller holder ASSY

- (1) Push the link arm in the direction of the arrow A, and turn the PF roller holder ASSY to remove the boss.
- (2) Slide the PF roller holder ASSY in the direction of the arrow B to remove it from the shaft, and remove the PF roller holder ASSY.

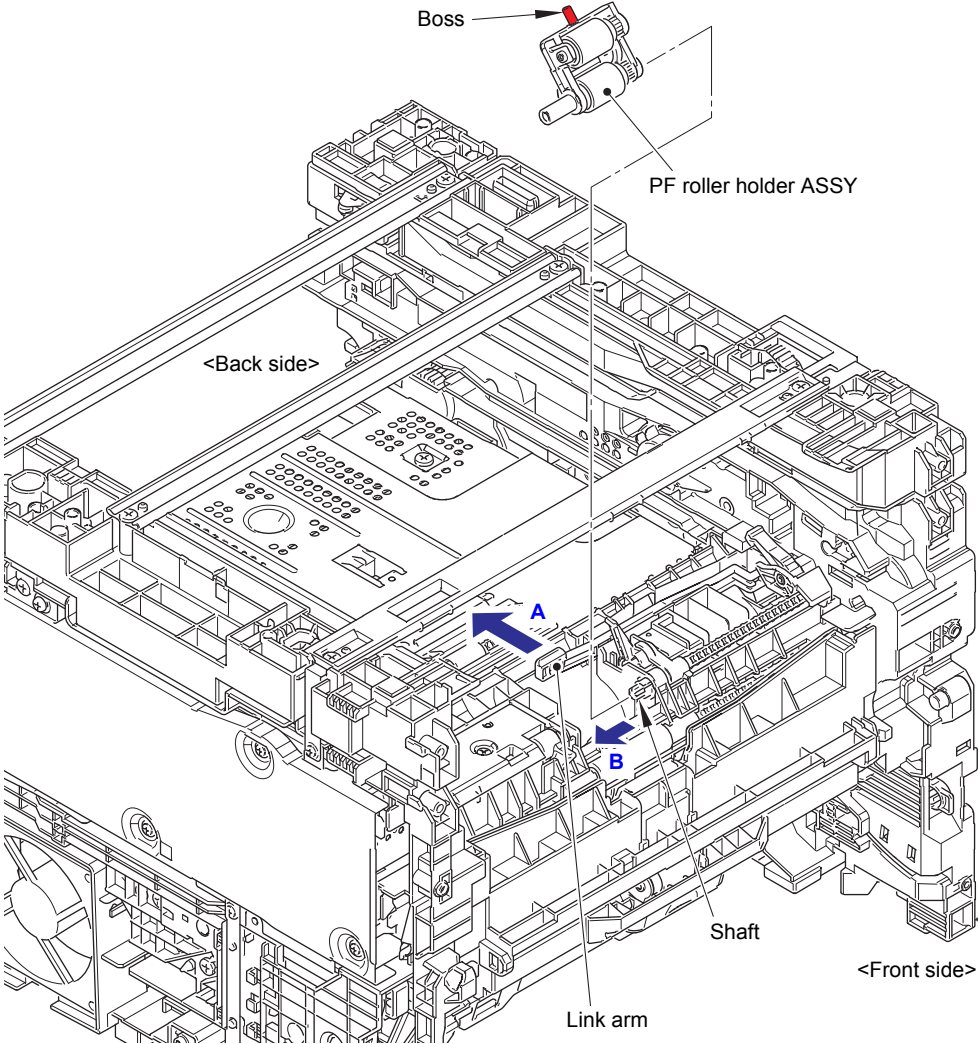

Fig. 3-81

9.22 Low-voltage power supply PCB ASSY

- (1) Remove the taptite cup S M3x8 SR screw and screw cup M3x8 (black) screw to remove the scanner ground plate.
- (2) Remove the three screw cup M3x8 (black) screws, taptite bind B M4x12 screw, screw pan M4x8 screw, washer spring 2-4, and washer 5 to remove the LV shield plate cover.
- (3) Remove the LVPS insulation sheet.

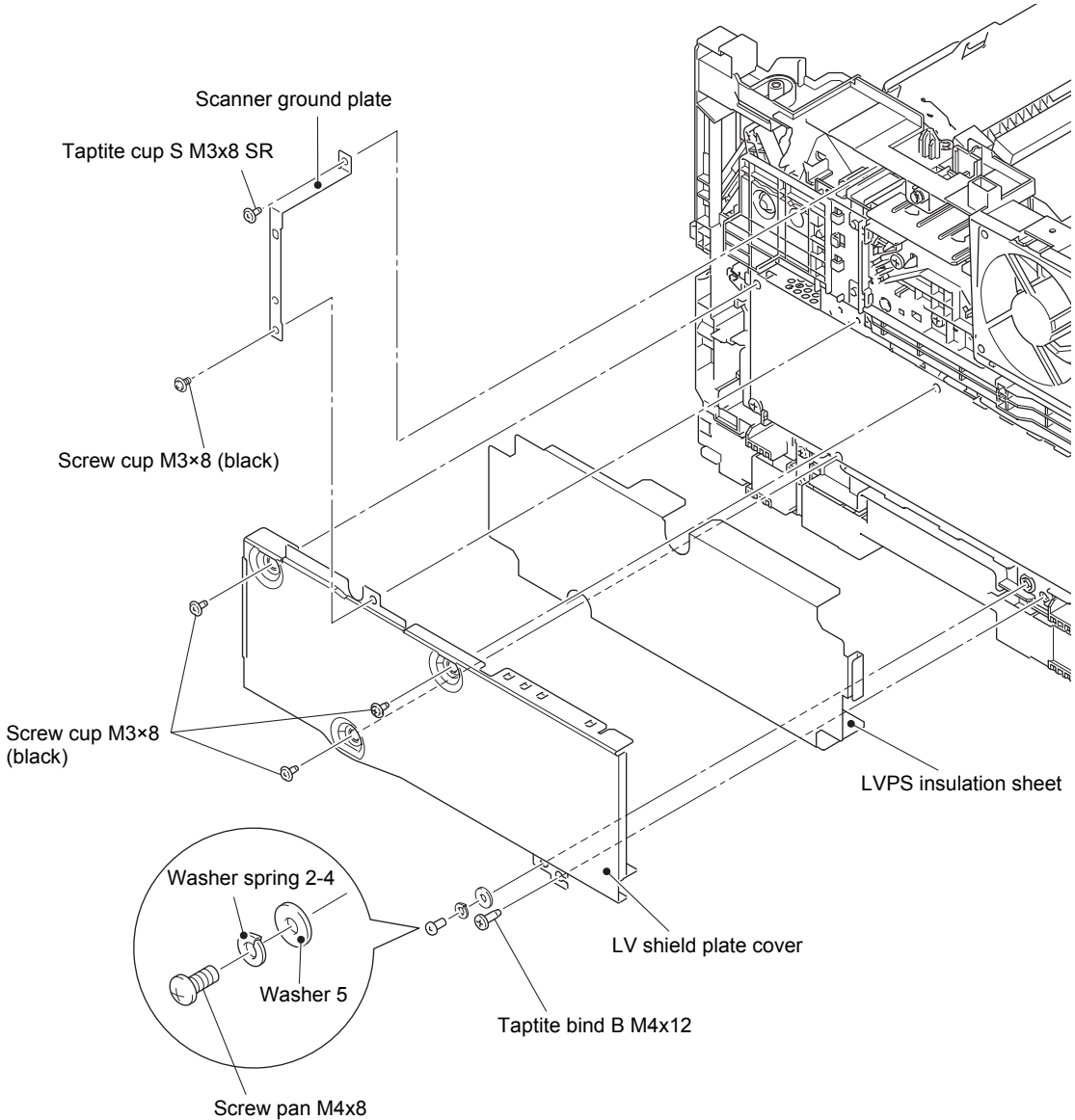

Fig. 3-82

- (4) Remove the screw pan M4x8 screw, washer spring 2-4, and washer 5 to remove the ground harness.
- (5) Remove the taptite flat B M3x10 screw, and remove the inlet.

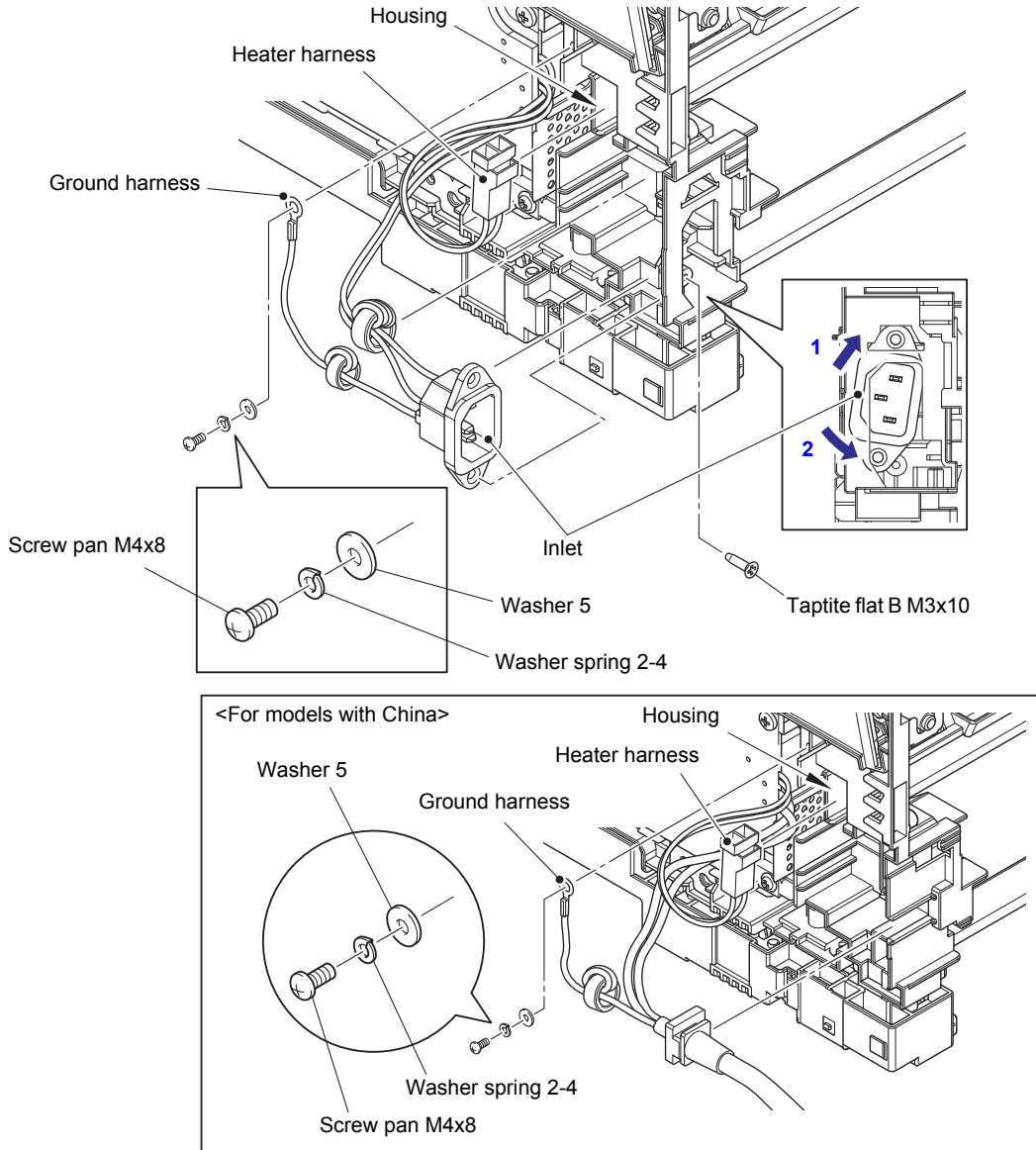

Fig. 3-83

Assembling Note:

- Attach the inlet as shown in the figure above.
- Insert the heater harness into the housing.
- For safety purposes, attach the washer spring 2-4 and washer 5 securely at positions described in the figure above.
- For safety purposes, perform the harness routing properly as described in "11. Rear side of the machine".

- (6) Remove the screw cup M3x8 (black) screw and two taptite bind B M4x12 screws. Remove the low-voltage power supply PCB ASSY, and disconnect the low-voltage power supply harness from the low-voltage power supply PCB ASSY.

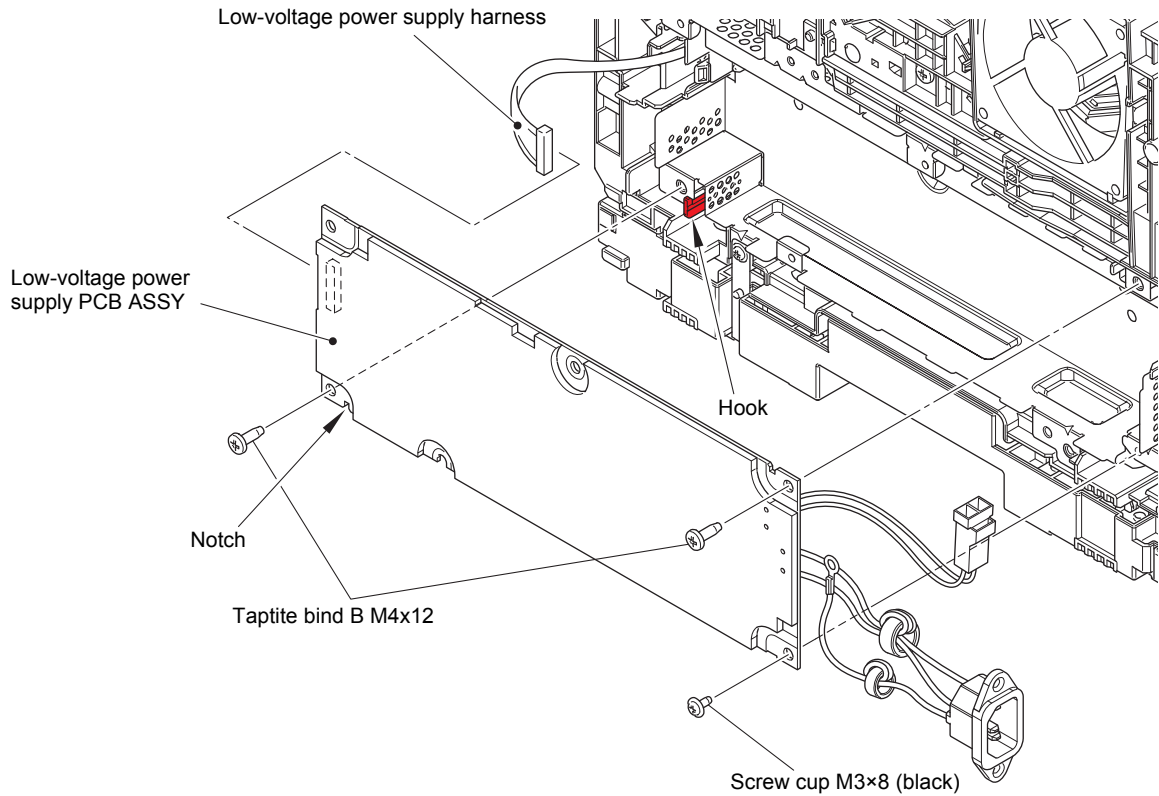

Fig. 3-84

Assembling Note:

- When attaching the low-voltage power supply PCB ASSY, engage the notch on the low-voltage power supply PCB ASSY with the hook.
- Check that the heater harness is housed in the frame L as shown in the figure below. Otherwise the harness may be caught in some sections of the machine, and may catch fire.

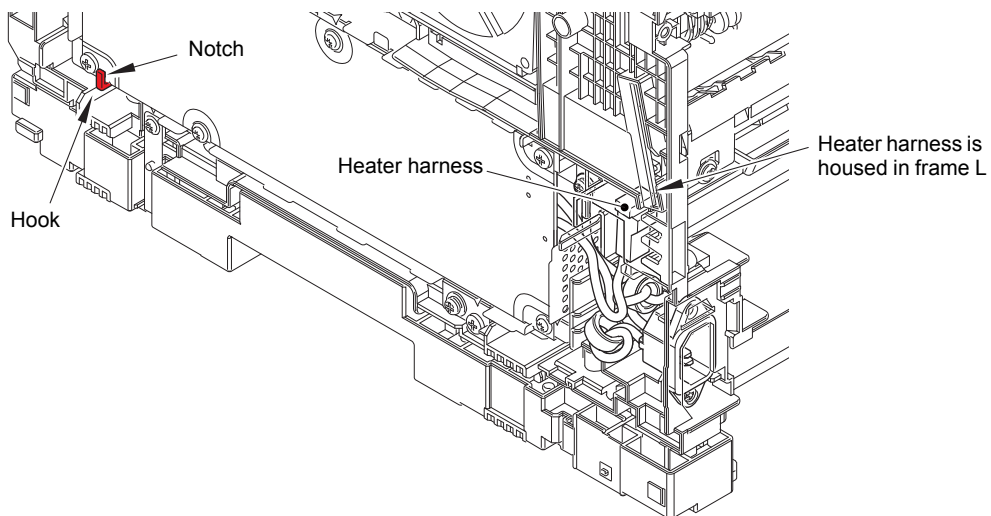

Fig. 3-85

9.23 Toner amount detection sensor PCB ASSY (light emission)

(1) Remove the LV shield plate ground spring from the LV shield plate and front chute.

■ **For models with 520-sheet T1**

(2) Remove the taptite cup S M3x8 SR screw, and lift the under bar ground plate R from the LV shield plate.

■ **For models with 250-sheet T1**

(3) Remove the taptite cup S M3x8 SR screw, and lift the under bar front from the LV shield plate.

■ **Common to all models**

(4) Remove the taptite bind B M4x12 screw. Release the two hooks, and remove the LV shield plate.

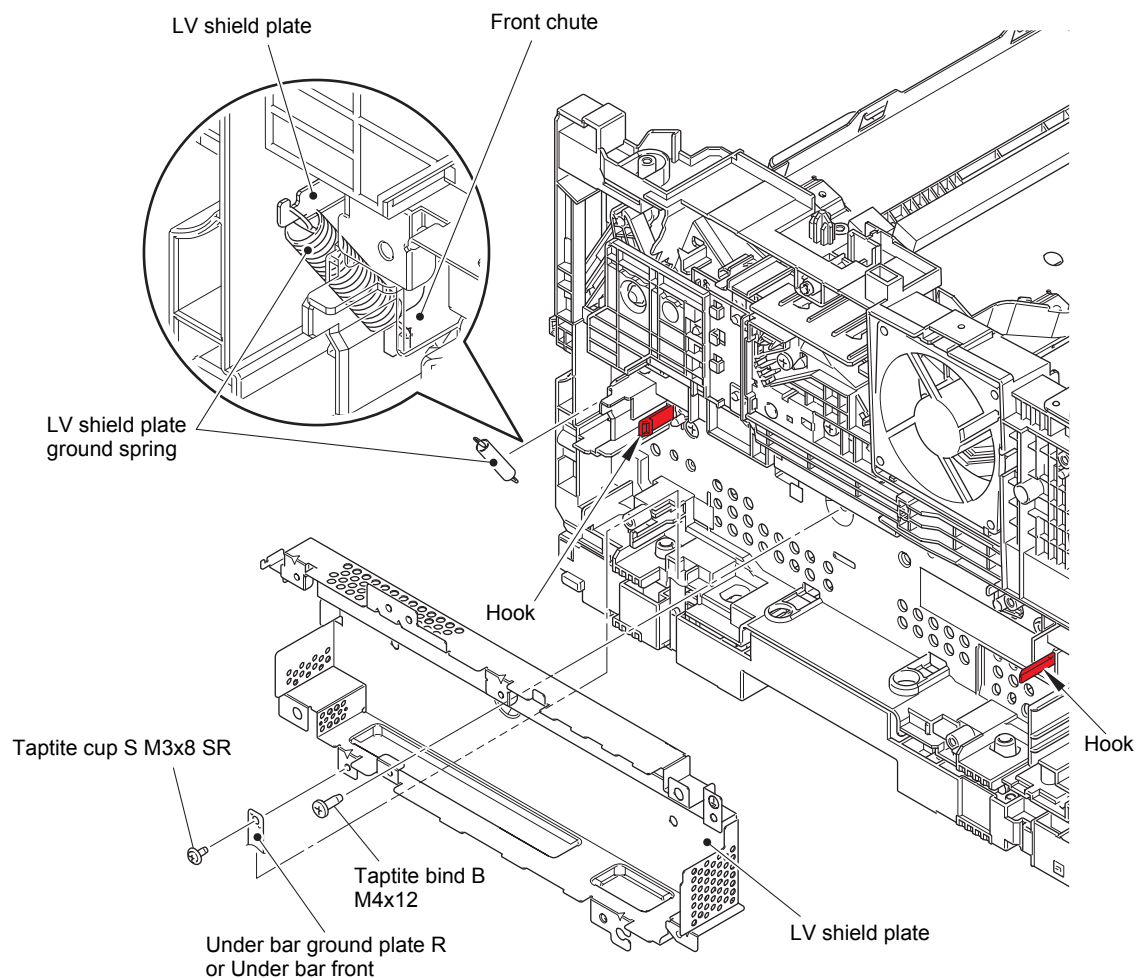

Fig. 3-86

Assembling Note:

- When attaching the LV shield plate, make sure that the under bar ground plate R or under bar front is on the upper side of the LV shield plate.

- (5) Remove the taptite bind B M4x12 screw. Release the hook and hold cover 1.
- (6) Release the toner amount detection sensor PCB harness (light emission) from the securing fixtures.
- (7) Remove the taptite pan B M3x8 screw, and remove the pinch ground spring. Release the hook, and remove the toner amount detection sensor PCB ASSY (light emission). Pull out the main fan harness from the toner amount detection sensor PCB ASSY (light emission).

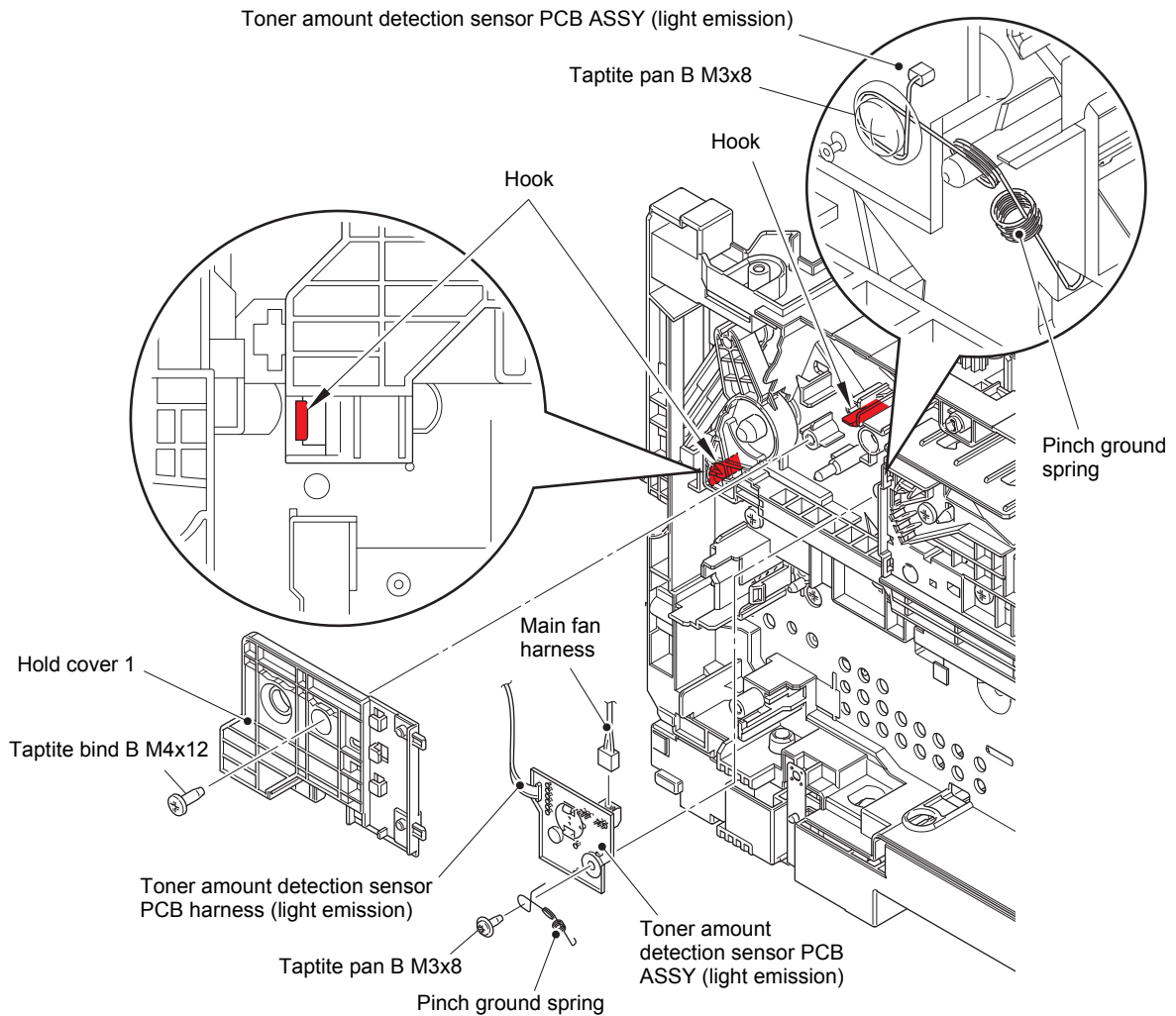

Fig. 3-87

Harness routing: Refer to "10. Left side of the machine", "11. Rear side of the machine".

Assembling Note:

- Hook the pinch ground spring at the position described in the figure above.

9.24 Main fan

- (1) Slide the straight cam in the direction of the arrow 1a to remove the boss on the nip release link from the groove on the straight cam. Slide the straight cam in the direction of the arrow 1b to remove it by engaging "A" with the groove.

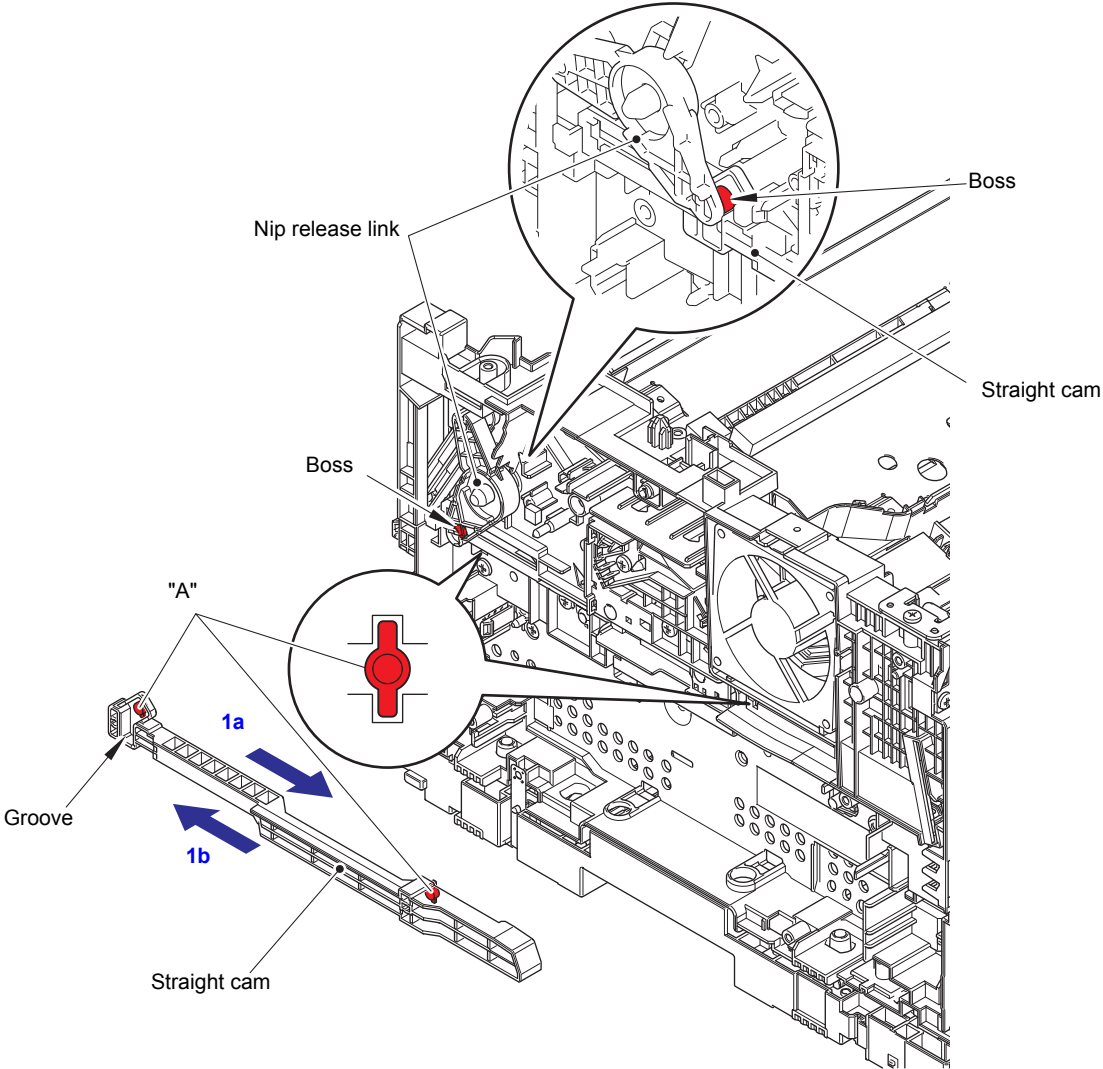

Fig. 3-88

- (2) Remove the two taptite bind B M4x12 screws. Release the hook, and open the upper side of the hold cover 2.
- (3) Release the main fan harness from the securing fixtures. Remove the main fan, and pull out the main fan harness from the hole.

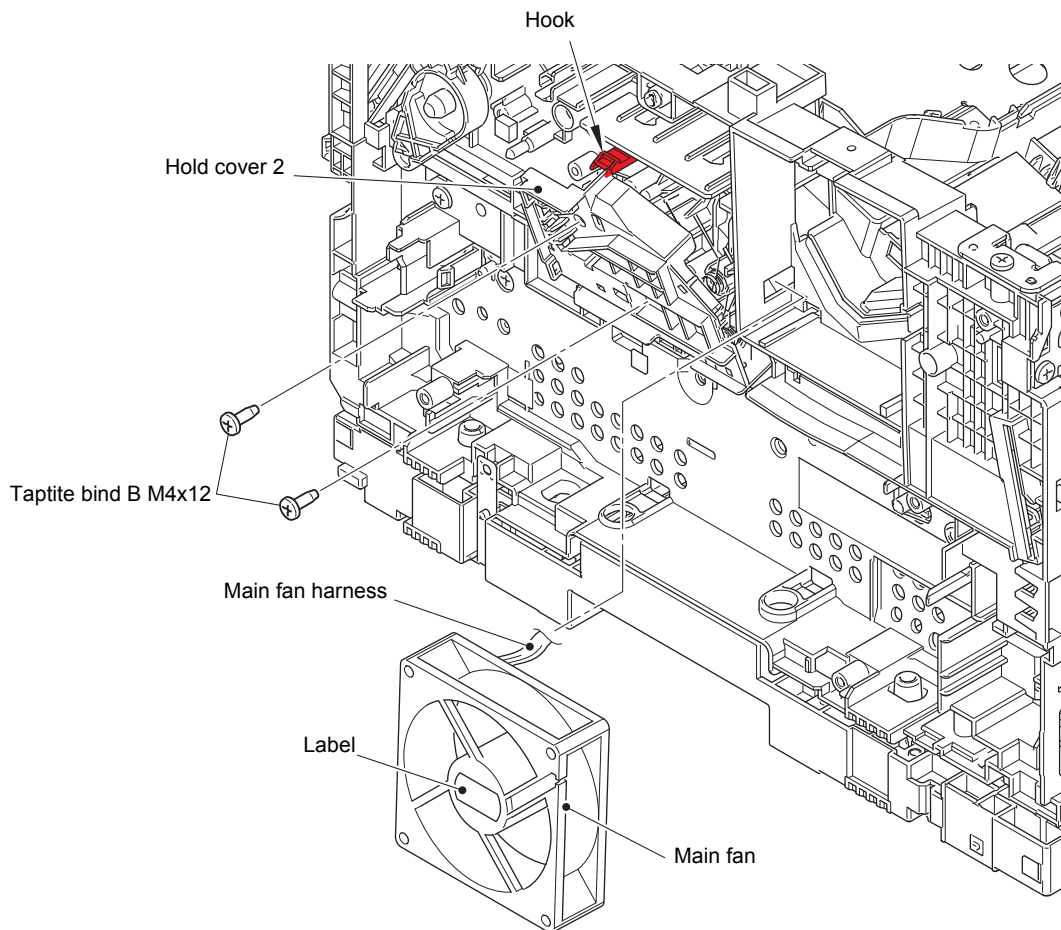

Fig. 3-89

Harness routing: Refer to ["11. Rear side of the machine"](#).

Assembling Note:

- Attach the main fan so that the surface with the label faces out.

9.25 Filter

(1) Release each hook, and remove the two filters from the air duct.

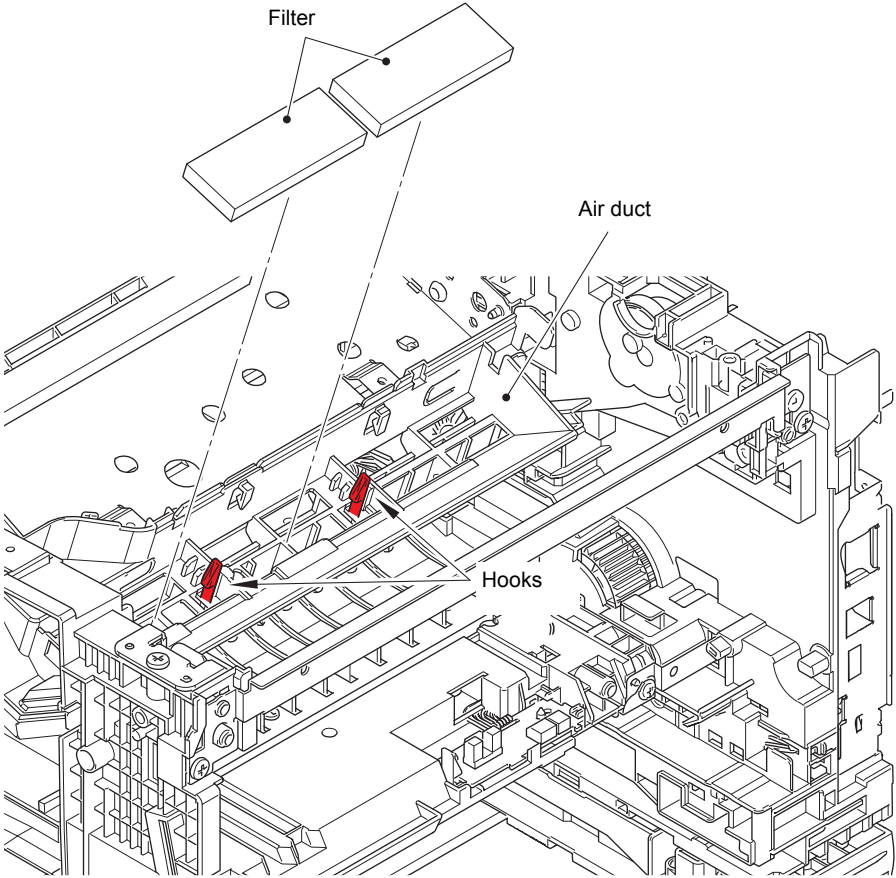

Fig. 3-90

9.26 Relay front PCB ASSY

- (1) Release the relay front harness from the securing fixtures.
- (2) Release the two hooks, and remove the front cover sensor. Release the front cover sensor harness from the securing fixtures.

Note:

- When removing the front cover sensor, push it from the rear to remove it.

- (3) Release the two hooks, and remove the relay front PCB ASSY. Disconnect all harnesses from the relay front PCB ASSY.

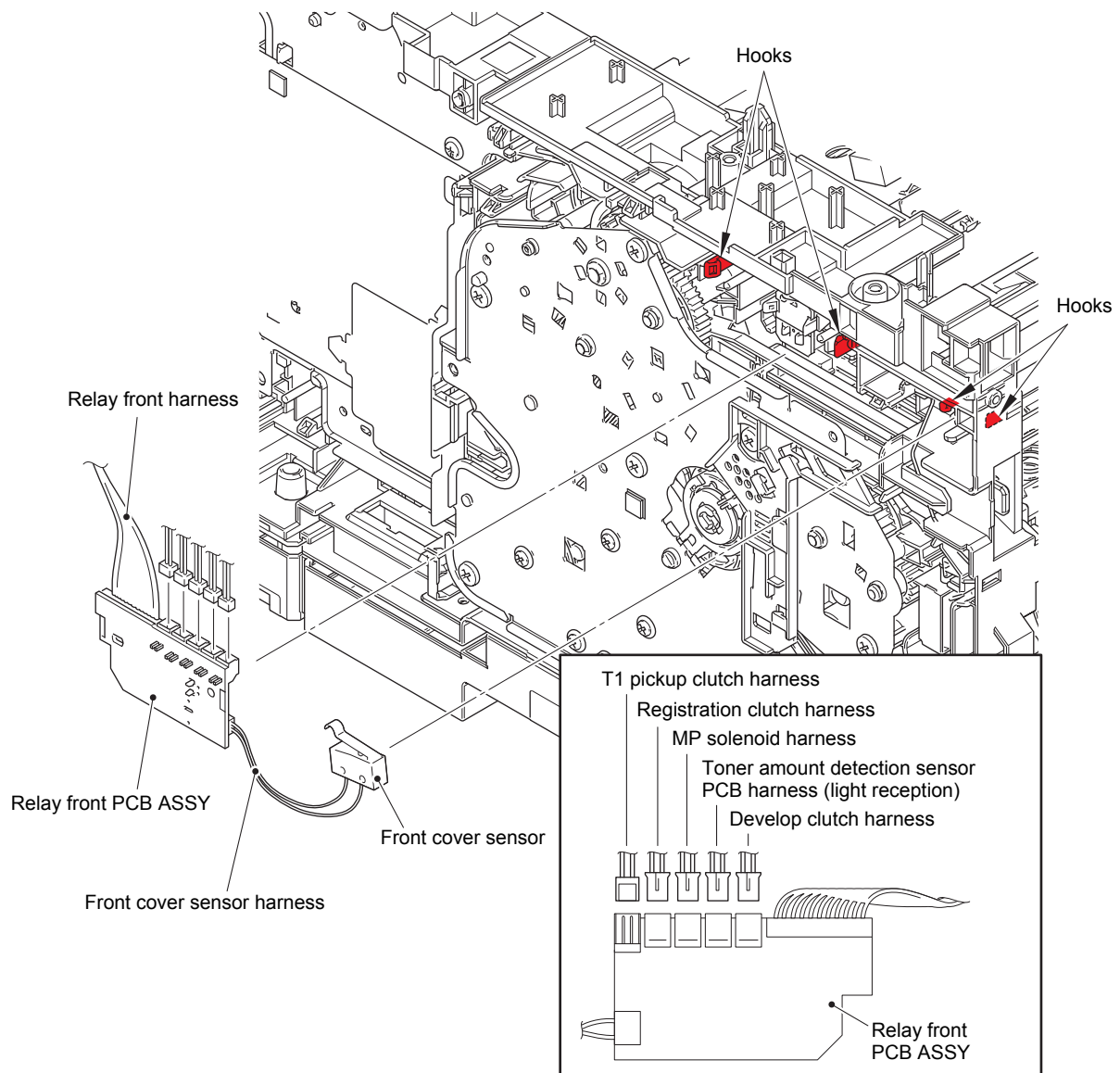

Fig. 3-91

Harness routing: Refer to "10. Left side of the machine".

9.27 Registration clutch / T1 pickup clutch

- (1) Release the registration clutch harness and the T1 pickup clutch harness from the securing fixtures.
- (2) Remove collar 6, and remove the registration clutch.
- (3) Release the hook, and remove the T1 pickup clutch.

Note:

- Be careful not to damage the hook on the T1 pickup clutch.

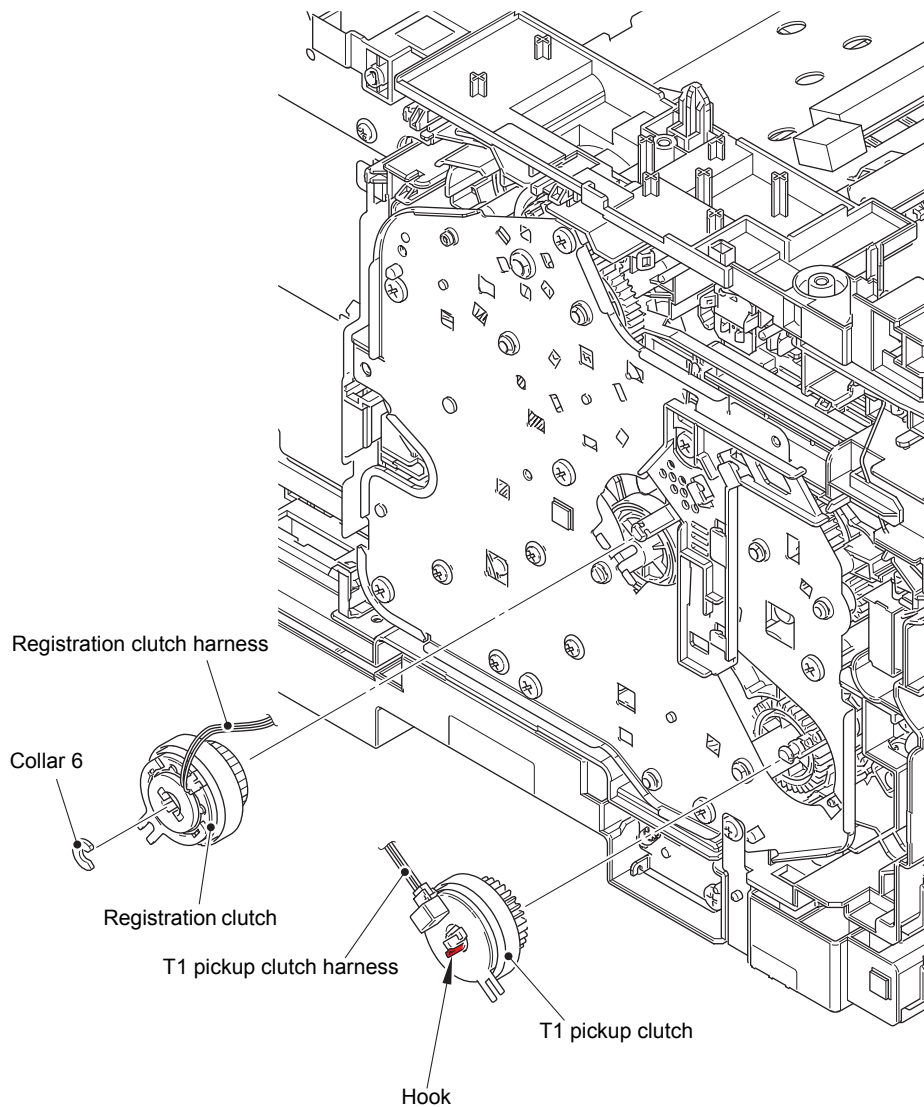

Fig. 3-92

Harness routing: Refer to [“10. Left side of the machine”](#).

9.28 Main frame L ASSY

■ For models with 520-sheet T1

- (1) Remove the two taptite bind B M4×12 screws, and remove the under bar rear.
- (2) Remove the two taptite bind B M4x12 screws, and remove the under bar center.
- (3) Remove the two taptite bind B M4×12 screws, and remove the under bar front, under bar cover and under bar ground plate R.
- (4) Remove the two taptite bind B M4x12 screws, and remove the top bar rear.
- (5) Remove the taptite cup S M3x8 SR screw, and remove the under bar ground plate L.
- (6) Remove the main PCB insulation sheet (transparent) and the main PCB insulation sheet (black).

Assembling Note:

- Make sure that the black main PCB insulation sheet is inserted properly into the hole of the transparent main PCB insulation sheet as shown in the illustration below.

- (7) Turn the registration roller bushing on the registration roller shaft to the position as shown in the figure below, and pull out the registration roller shaft.

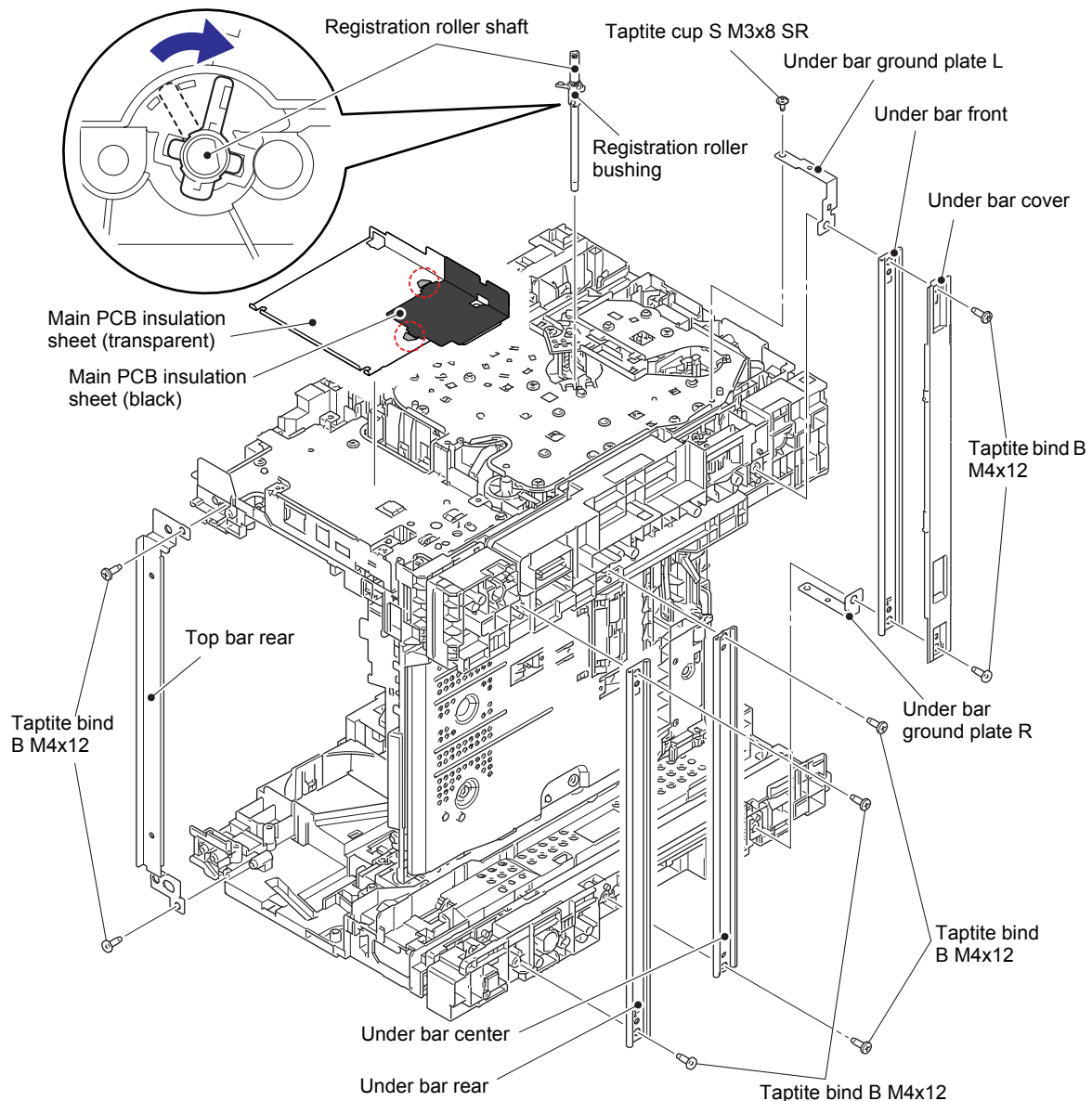

Fig. 3-93

■ **For models with 250-sheet T1**

- (8) Remove the taptite cup S M3x8 SR screw and two taptite bind B M4x12 screws to remove the under bar front.
- (9) Remove the main PCB insulation sheet (transparent) and the main PCB insulation sheet (black).

Assembling Note:

- Make sure that the black main PCB insulation sheet is inserted properly into the hole of the transparent main PCB insulation sheet as shown in the illustration below.

- (10) Turn the registration roller bushing on the registration roller shaft to the position as shown in the figure below, and pull out the registration roller shaft.

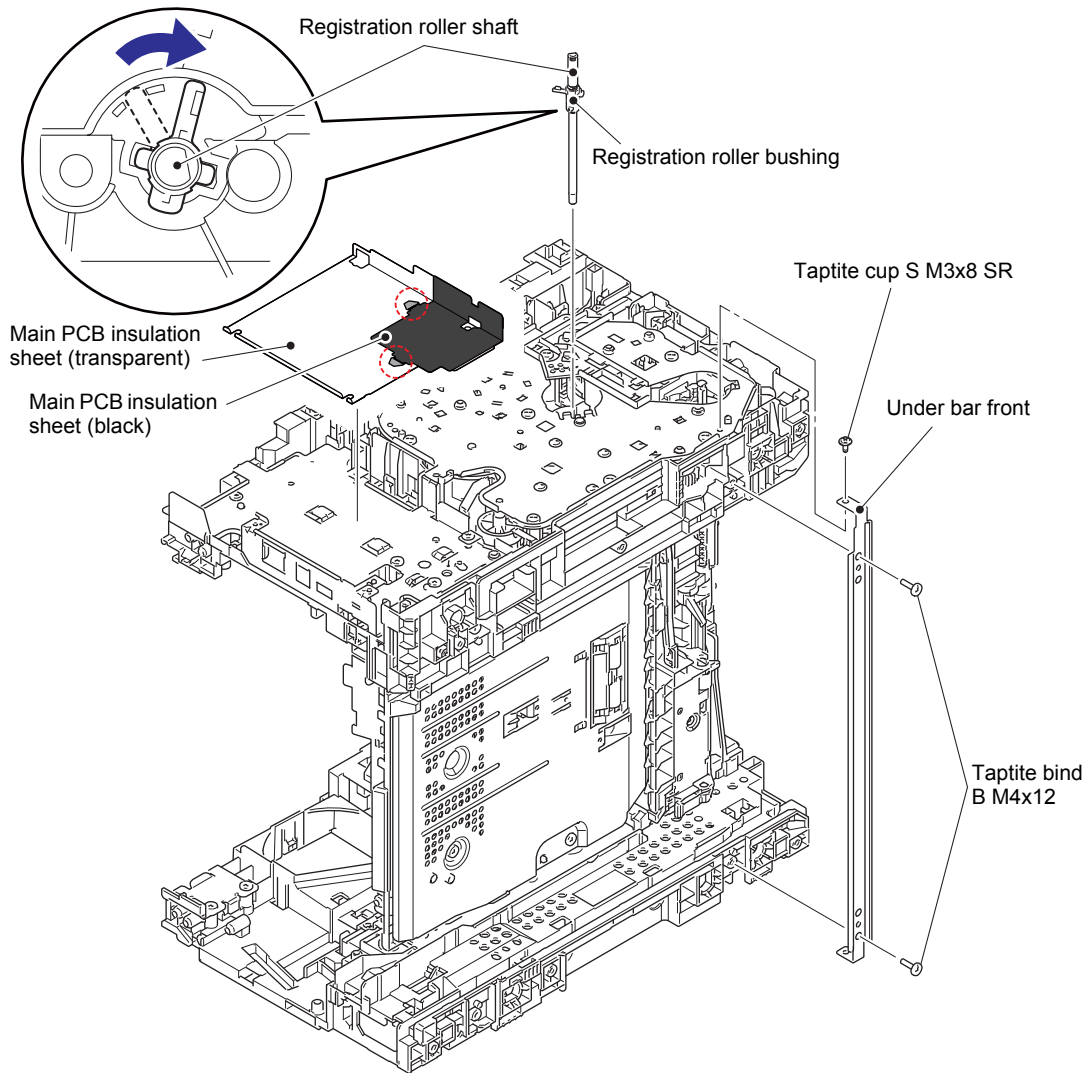
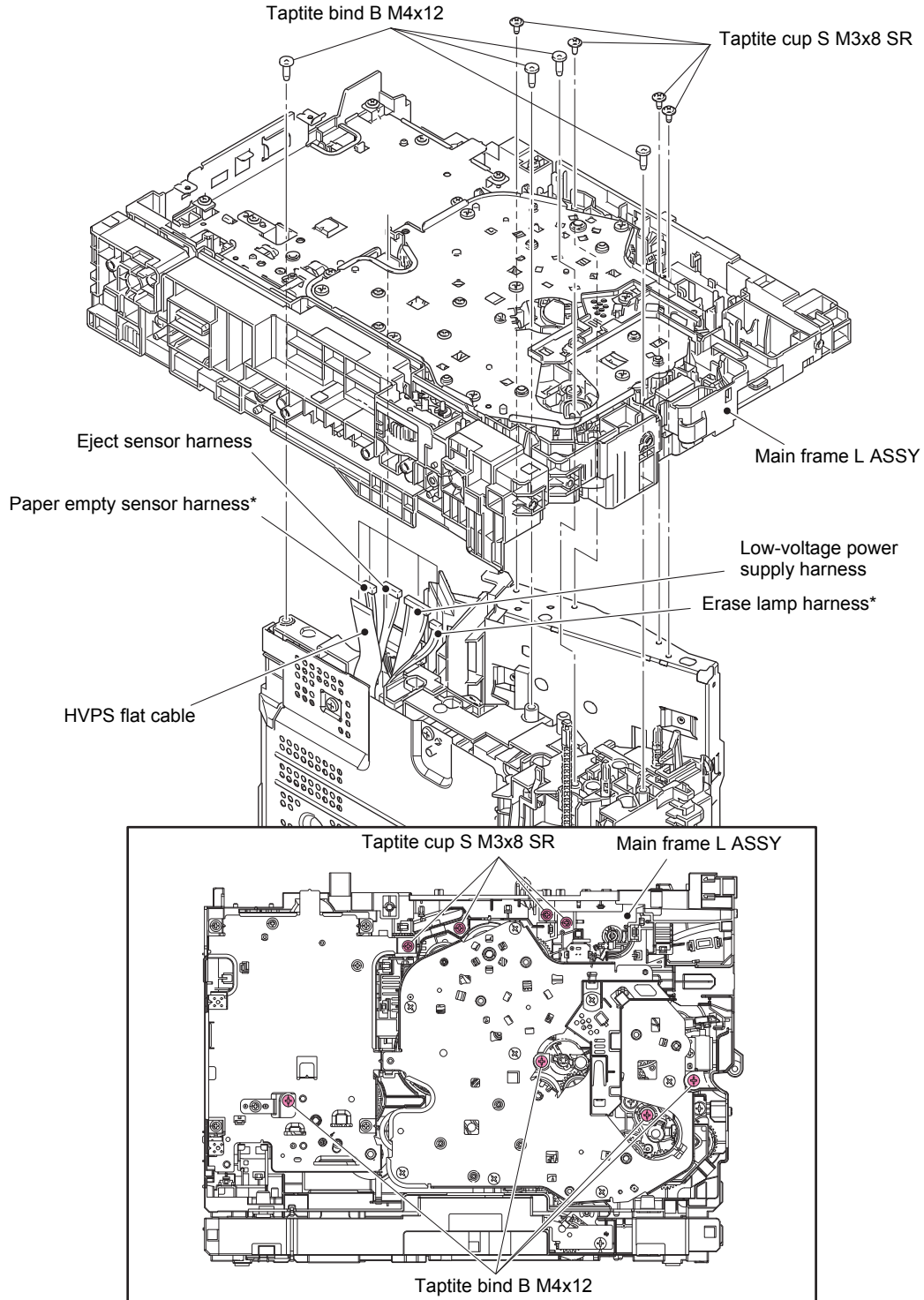

Fig. 3-94

■ **Common to all models**

- (11) Remove the four taptite cup S M3x8 SR screws and four taptite bind B M4x12 screws. Remove the main frame L ASSY, and pull out the erase lamp harness*, paper empty sensor harness*, low-voltage power supply harness, eject sensor harness, and HVPS flat cable from the hole of the main frame L ASSY.



* Models with 520-sheet T1 only

Fig. 3-95

9.29 Paper feed motor

- (1) Remove the eight taptite bind B M4x12 screws, and remove the drive sub ASSY from the main frame L ASSY.

Note:

- When removing the drive sub ASSY, be careful not to damage the shaft of the drive sub ASSY.

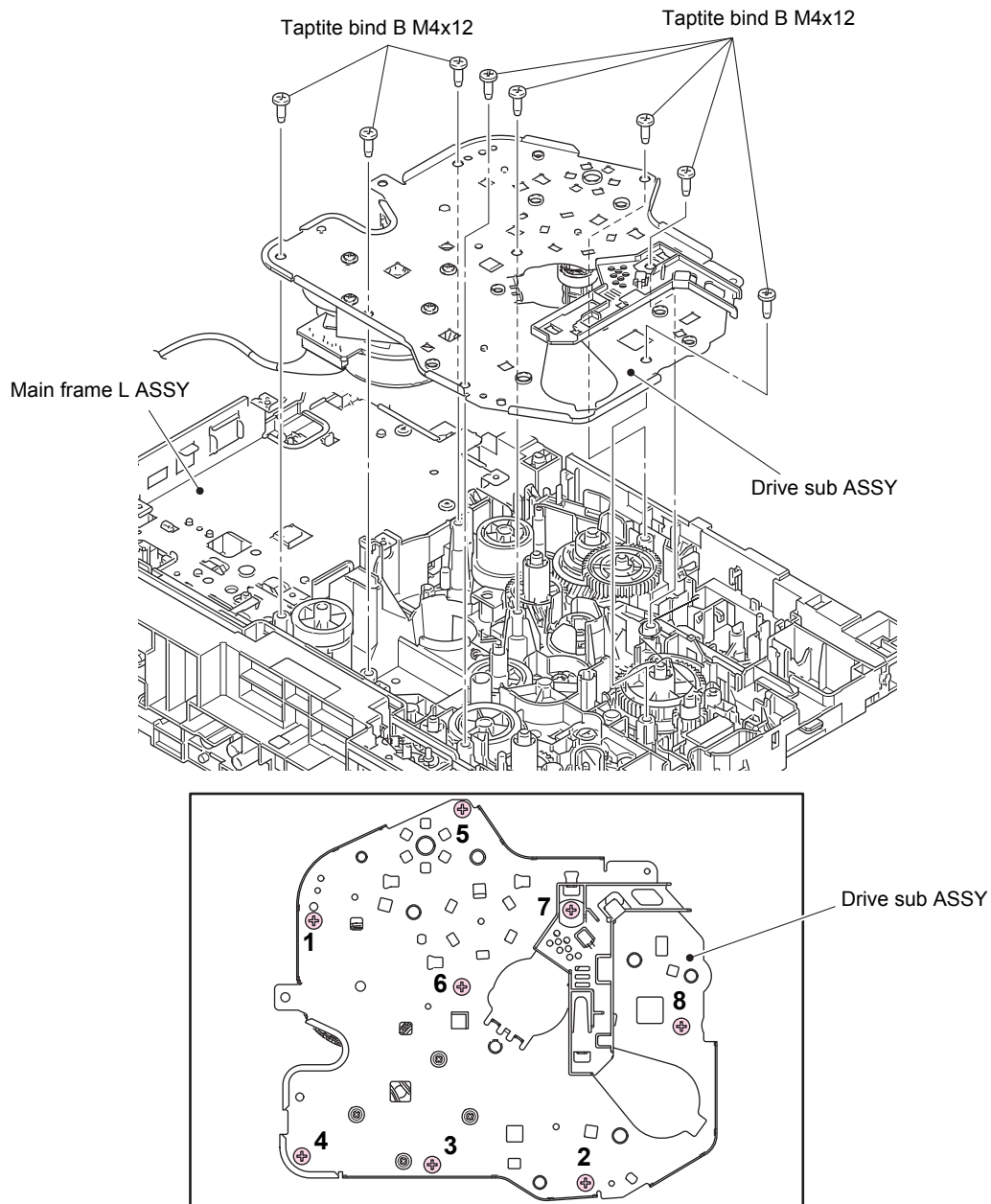

Fig. 3-96

Assembling Note:

- When securing the drive sub ASSY with screws, tighten the screws in the sequence of the numbers engraved on the drive sub ASSY.

Note:

- Do not allow the metallic gear shaft of the paper feed motor and drive sub ASSY to face down. Failure to observe this may cause the steel plate to bend.

- (2) Remove the four taptite cup S M3x8 SR screws, and remove the paper feed motor plate from the drive sub ASSY.
- (3) Remove the fuser gear 35/83R and the DRM gear 32/83R from the paper feed motor plate.

Note:

- Be careful not to damage the gear teeth.

- (4) Remove the three screw bind M3x4 screws, and remove the paper feed motor from the paper feed motor plate.
- (5) Disconnect the paper feed motor harness from the paper feed motor.

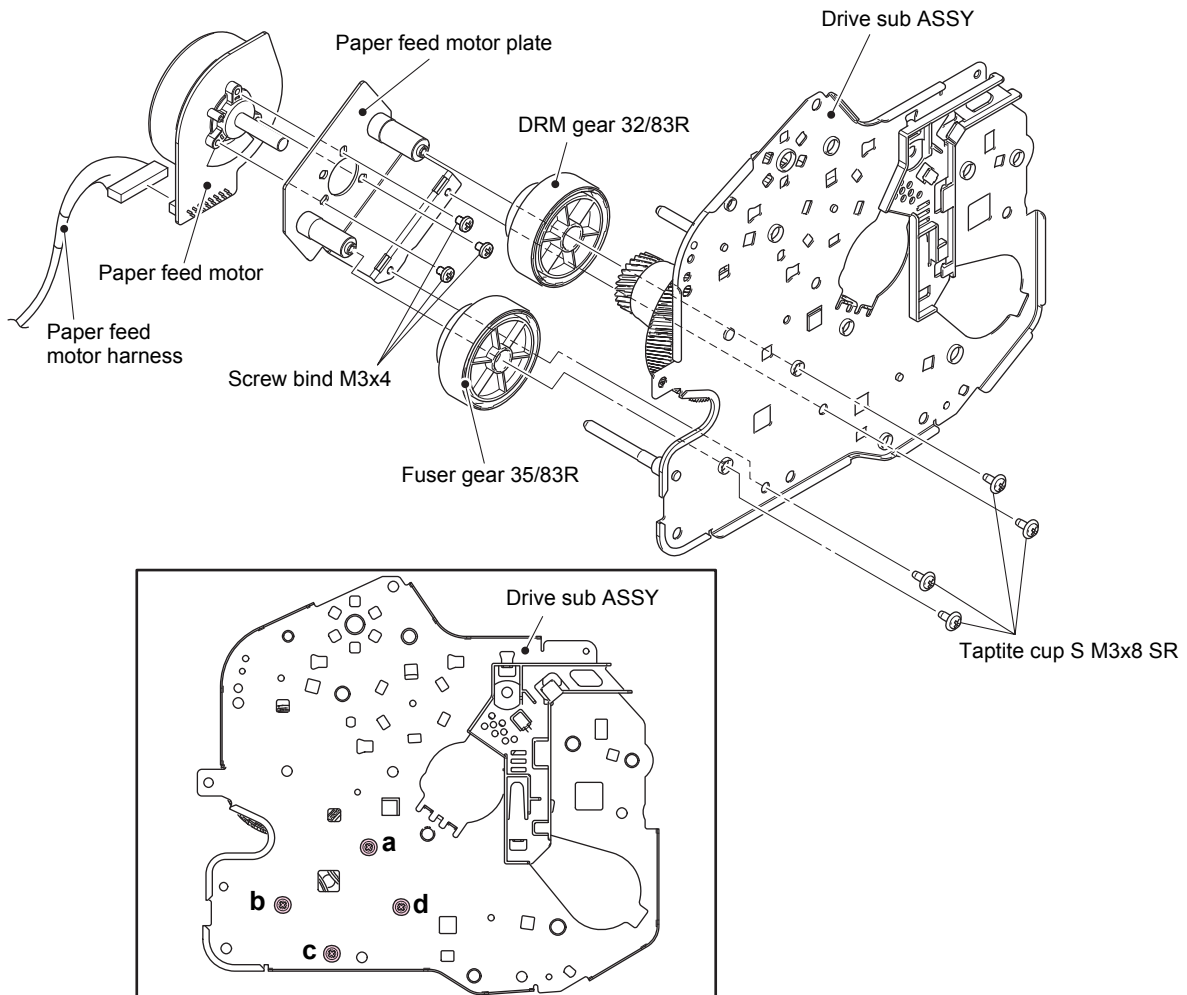

Fig. 3-97

Assembling Note:

- When securing the paper feed motor on the drive sub ASSY with screws, tighten the screws in the sequence of the alphabets engraved on the drive sub ASSY.

9.30 Develop joint gear 37 / Develop joint

- (1) Tilt the develop joint to remove it from the drive sub ASSY, and then remove the develop joint spring from the drive sub ASSY.

Note:

- When removing the develop joint, be careful not to damage the hooks.

- (2) Pull out the develop joint gear 37 from the drive sub ASSY.

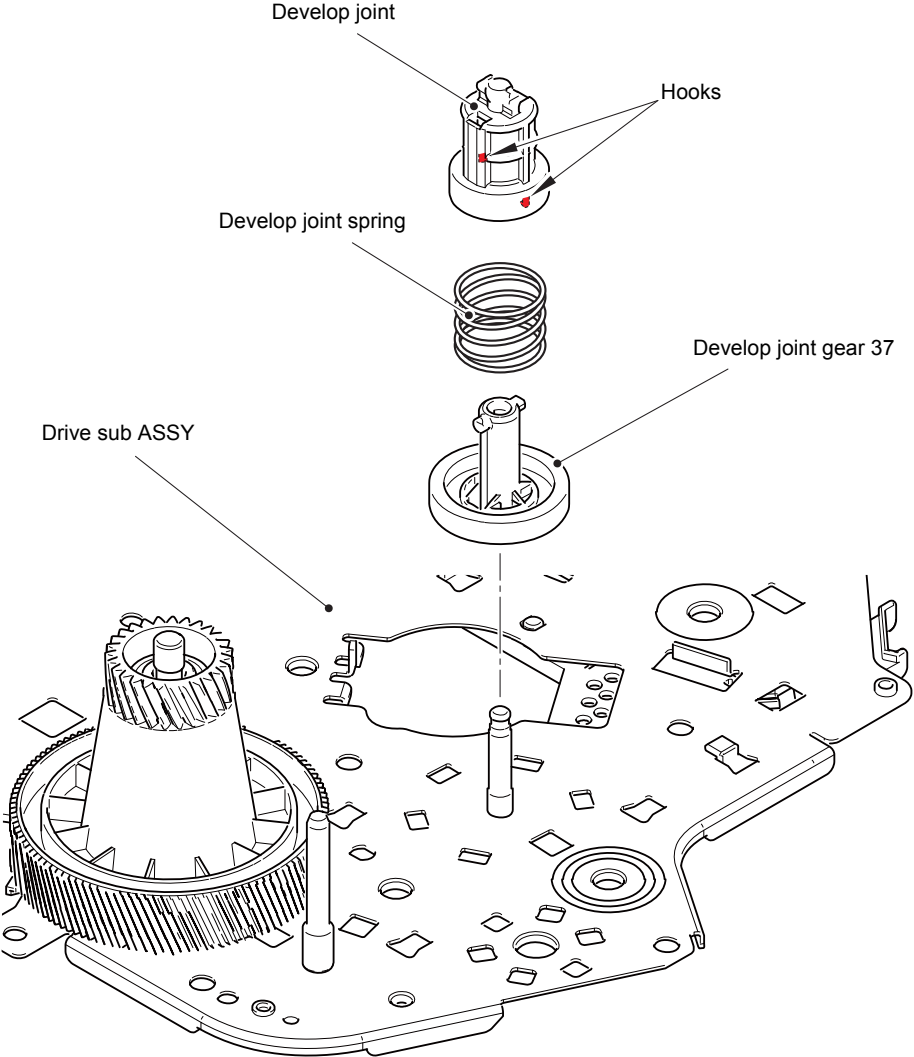

Fig. 3-98

9.31 Toner amount detection sensor PCB ASSY (light reception)

- (1) Release the toner amount detection sensor PCB harness (light reception) from the securing fixtures.
- (2) Release the two hooks, and remove the toner amount detection sensor PCB ASSY (light reception) from the main frame L ASSY.
- (3) Release the two hooks, and remove the toner LED holder from the toner amount detection sensor PCB ASSY (light reception).

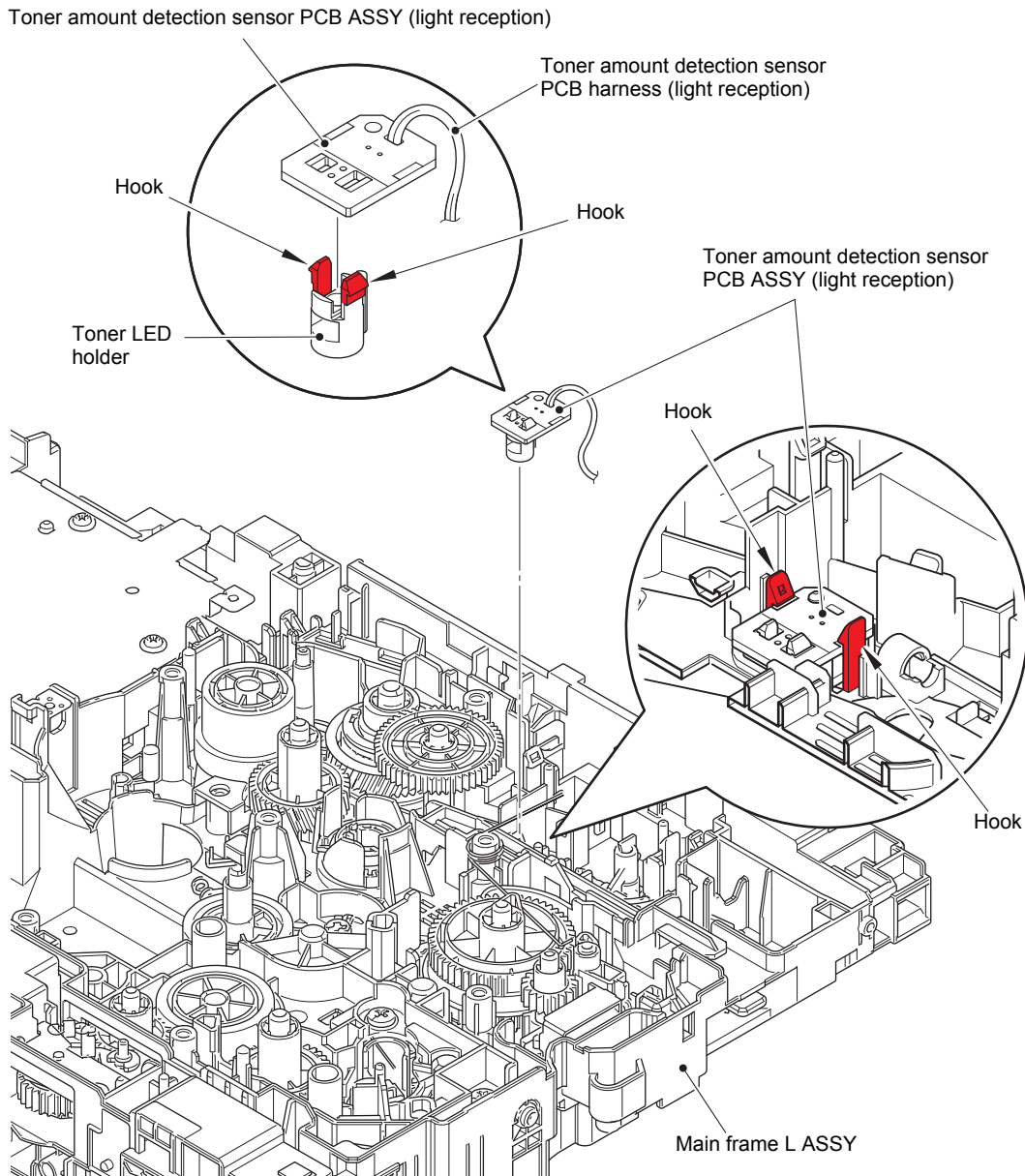

Fig. 3-99

Harness routing: Refer to "10. Left side of the machine".

9.32 MP solenoid

- (1) Remove the MP drive gear 18 from the main frame L ASSY.
- (2) Release the MP solenoid harness from the securing fixtures.
- (3) Remove the taptite bind B M3x10 screw, and remove the MP solenoid and the MP solenoid lever from the main frame L ASSY.
- (4) Remove the MP solenoid lever and the MP solenoid spring from the MP solenoid.

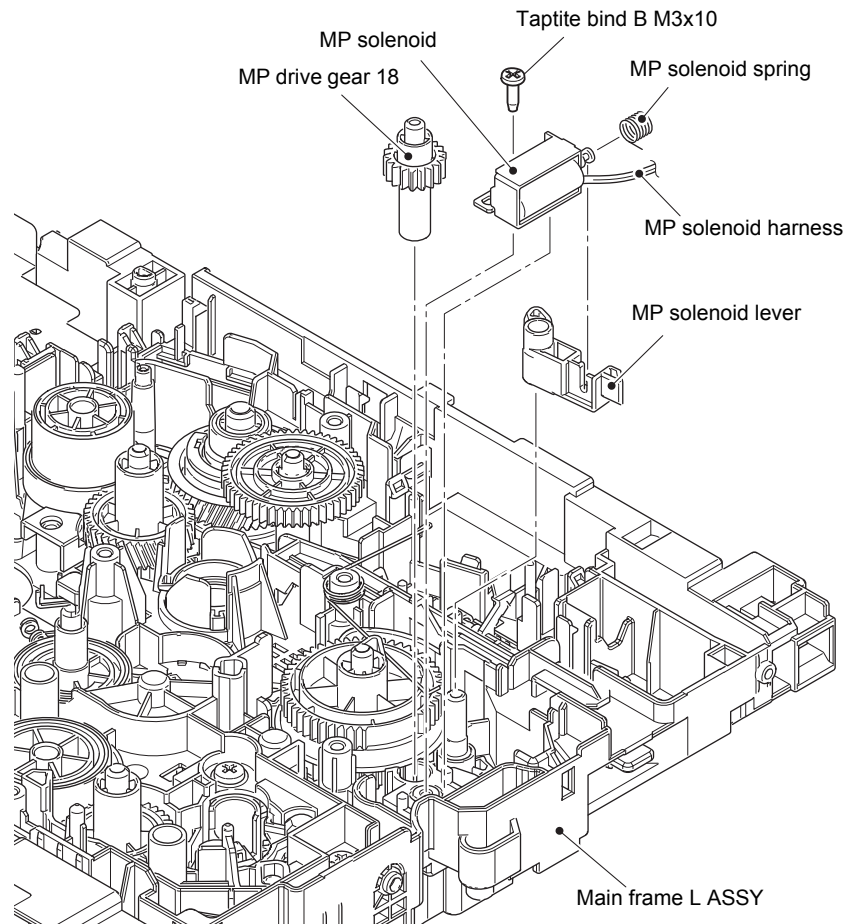

Fig. 3-100

Harness routing: Refer to "10. Left side of the machine".

9.33 Develop clutch 51R

- (1) Remove the develop idle gear 53 from the main frame L ASSY.
- (2) Remove the develop shaft gear 22 from the main frame L ASSY.
- (3) Release the develop clutch harness from the securing fixtures, and remove the develop clutch 51R from the main frame L ASSY.

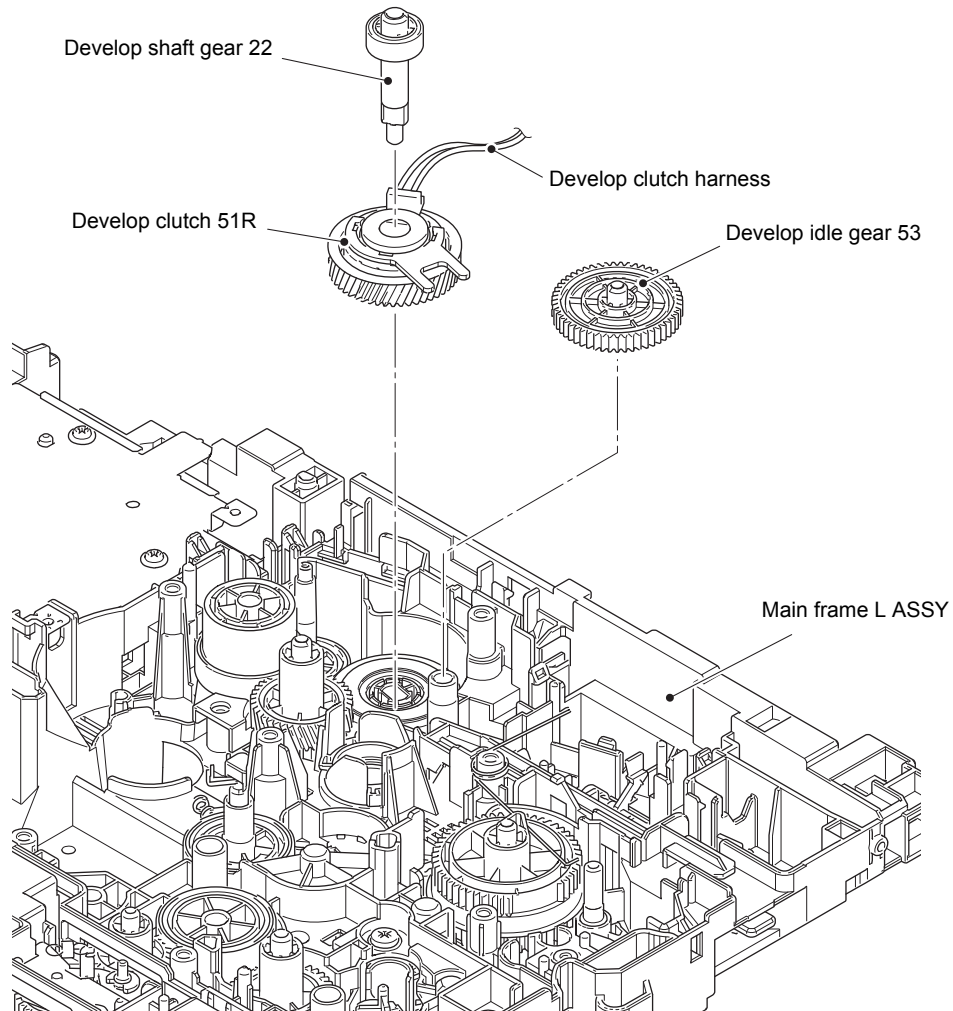

Fig. 3-101

Harness routing: Refer to ["10. Left side of the machine"](#).

9.34 Internal temperature sensor

- (1) Release the internal temperature sensor harness from the securing fixtures, and remove the internal temperature sensor.

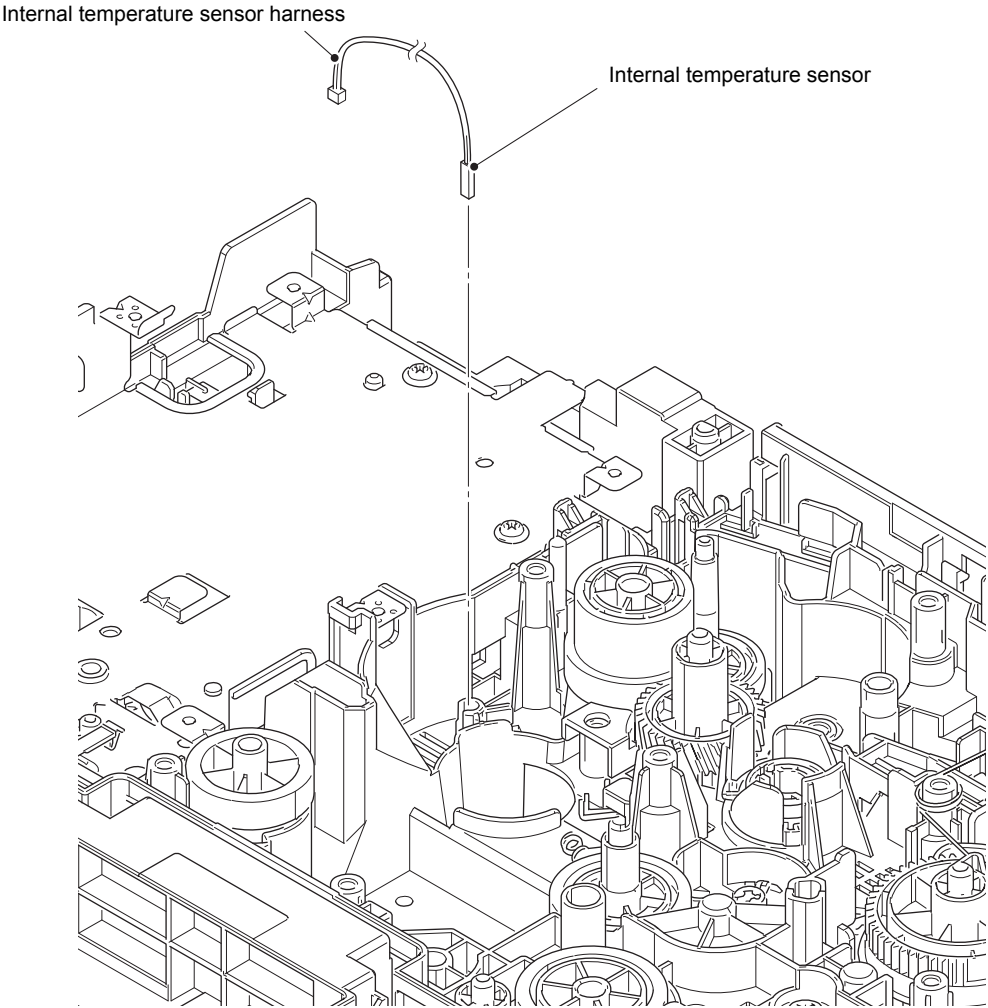

Fig. 3-102

Harness routing: Refer to "10. Left side of the machine".

9.35 Fuser drive gear 39

- (1) Remove the three taptite bind B M4x12 screws and two taptite cup S M3x8 SR screws. Release the two hooks to remove the main PCB shield calking ASSY from the main frame L ASSY.

Note:

- Do not allow the metallic gear shaft of the main PCB shield calking ASSY to face down. Failure to observe this may cause the steel plate to bend.

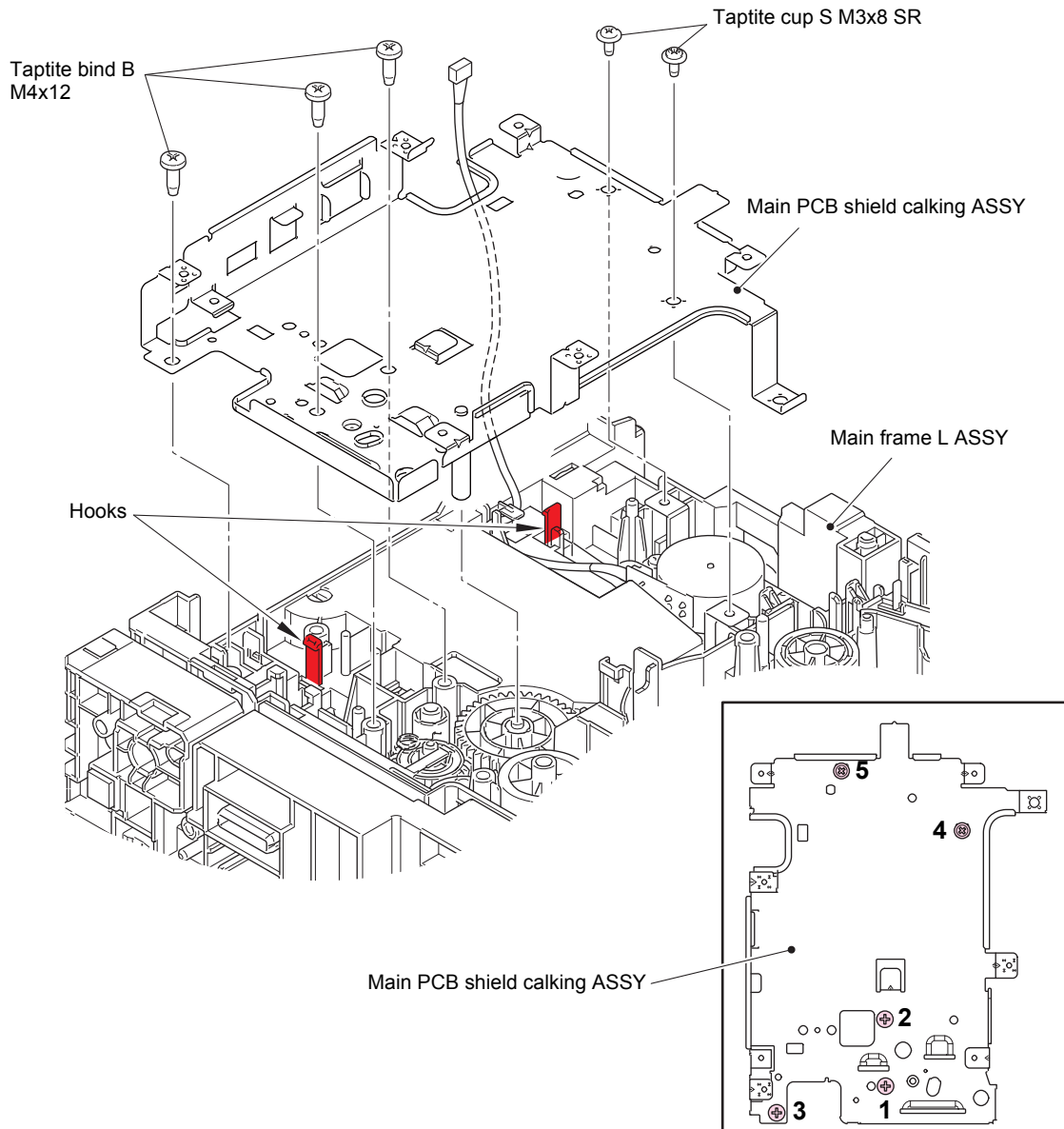

Fig. 3-103

Assembling Note:

- When securing the main PCB shield calking ASSY with screws, tighten the screws in the sequence of the numbers engraved on the main PCB shield calking ASSY.

(2) Remove the fuser drive gear 39 from the main frame L ASSY.

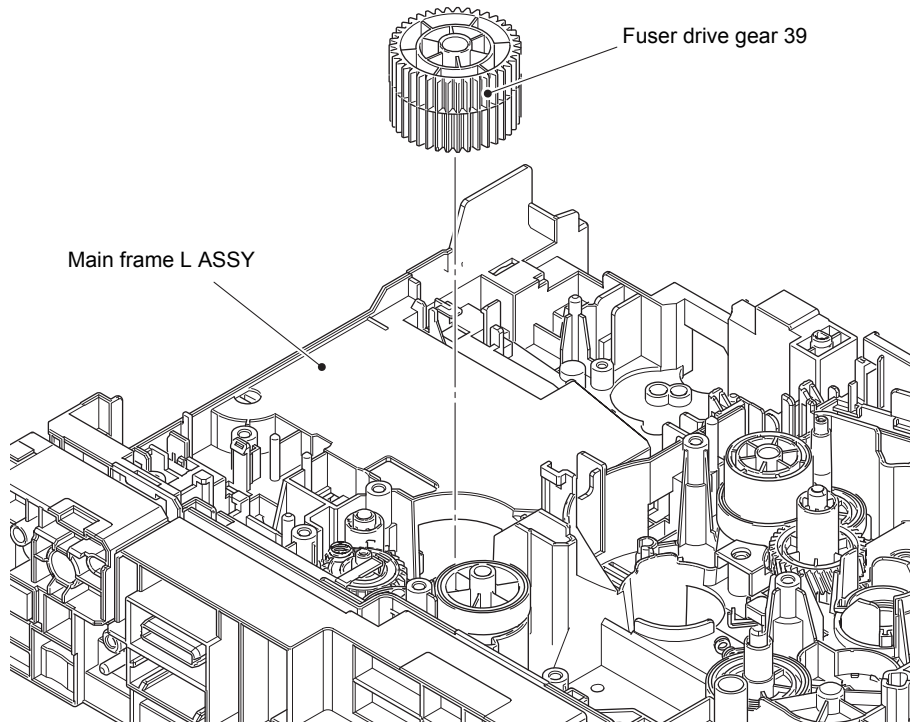

Fig. 3-104

9.36 Eject motor

- (1) Release the eject motor harness from the securing fixtures.
- (2) Remove the two taptite bind B M3x10 screws, and remove the eject motor plate from the main frame L ASSY.
- (3) Remove the screw bind M3x4 screw. Turn the eject motor in the direction of the arrow, and remove it from the eject motor plate.
- (4) Disconnect the eject motor harness from the eject motor.

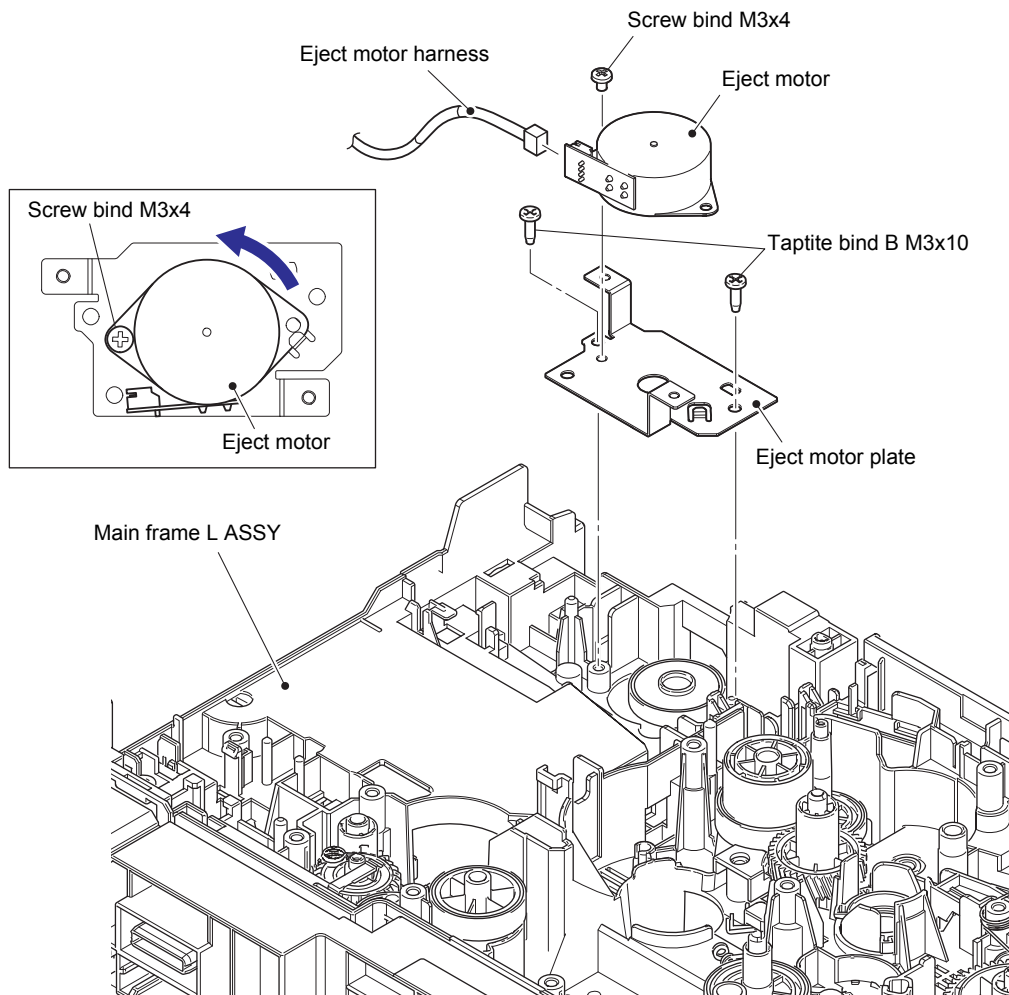

Fig. 3-105

Harness routing: Refer to "10. Left side of the machine".

9.37 Back cover/duplex tray sensor

- (1) Release the back cover/duplex tray sensor harness from the securing fixtures.
- (2) Release the two hooks, and remove the back cover/duplex tray sensor from the main frame L ASSY.

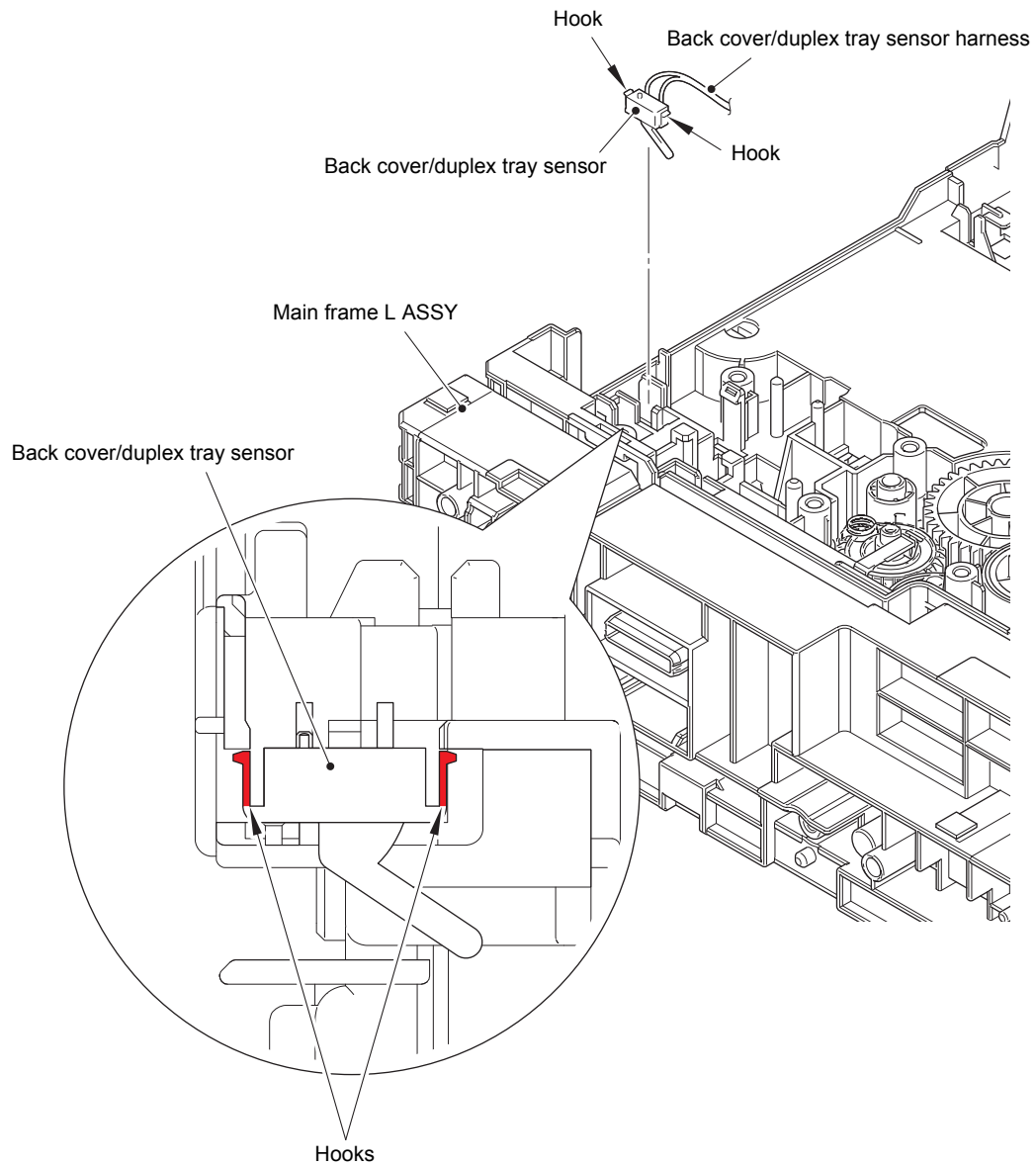

Fig. 3-106

Harness routing: Refer to [“10. Left side of the machine”](#).

Assembling Note:

- When connecting the back cover/duplex tray sensor, insert it at an angle from the right side.

9.38 LT/TT connector

■ For models with 520-sheet T1

- (1) Remove the three taprite bind B M4x30 screws, and remove the bottom frame L from the main frame L ASSY. Then pull out the LT/TT connector harness from the hole of the main frame L ASSY.
- (2) Release the two hooks A, and remove the LT/TT connector from the bottom frame L.

■ For models with 250-sheet T1

- (3) Release the two hooks A, and remove the LT/TT connector from the main frame L ASSY.

■ Common to all models

- (4) Release the two hooks B to disconnect the LT/TT connector harness from the LT/TT connector.

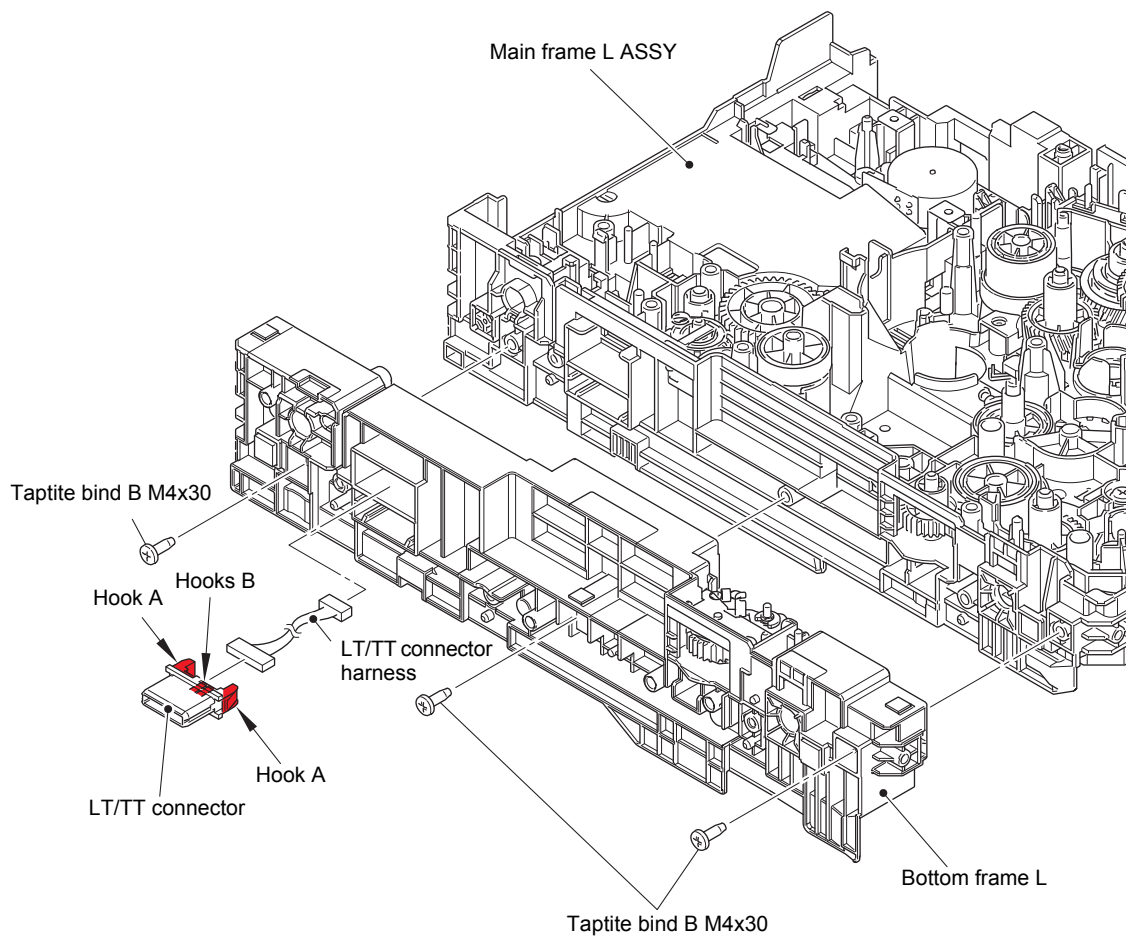

Fig. 3-107

- (2) Remove the HV insulation sheet.
- (3) Release the HVPS flat cable from the securing fixtures.
- (4) Remove the two taptite bind B M4x12 screws. Release the two hooks, and remove the high-voltage power supply PCB ASSY and feed ground spring.

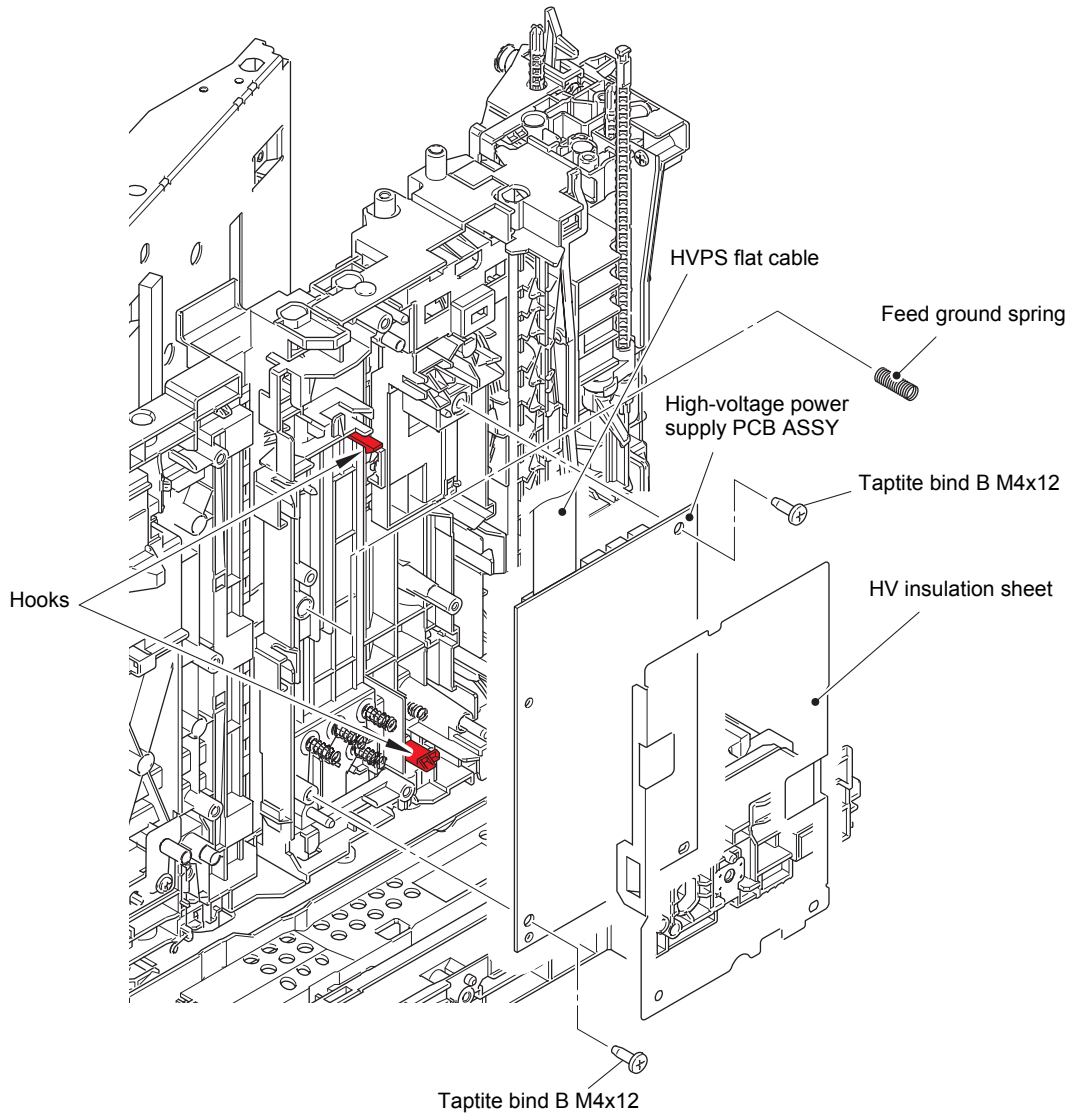

Fig. 3-109

Harness routing: Refer to **“13. Bottom side of the machine (High-voltage power supply PCB ASSY)”**.

- (5) Disconnect the registration front/rear sensor harness, T1 paper feed sensor harness and the MP paper empty sensor harness from the high-voltage power supply PCB ASSY to remove the high-voltage power supply PCB ASSY.
- (6) Disconnect the HVPS flat cable from the high-voltage power supply PCB ASSY.

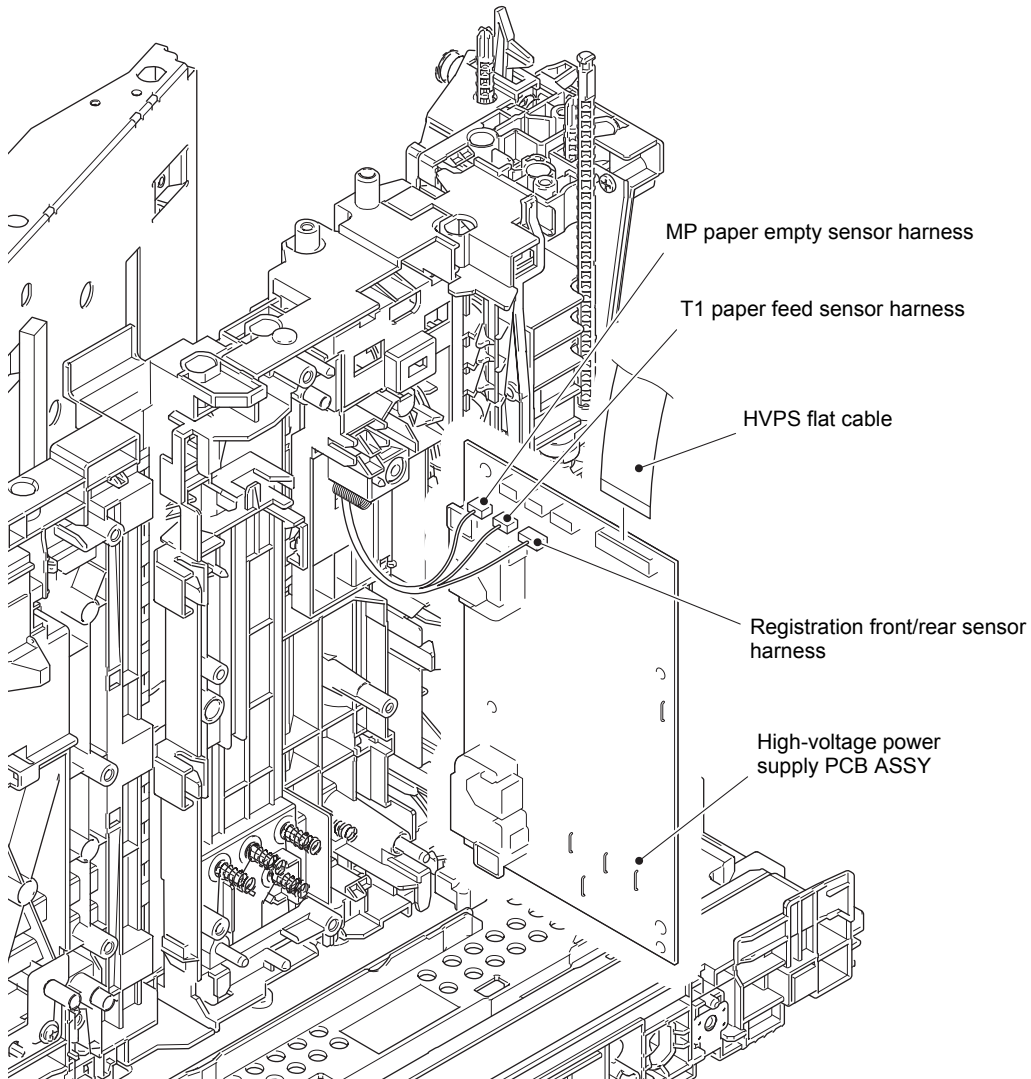

Fig. 3-110

Harness routing: Refer to “13. Bottom side of the machine (High-voltage power supply PCB ASSY)”.

Assembling Note:

- Fold the HVPS flat cable at the positions shown in the figure below.

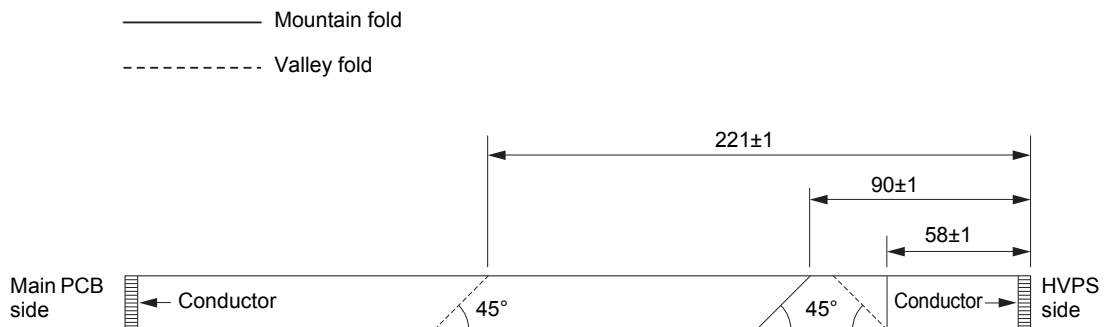

Fig. 3-111

9.40 Eject sensor PCB ASSY

- (1) Release the eject sensor harness from the securing fixtures.
- (2) Release the hook, and remove the eject sensor PCB ASSY.

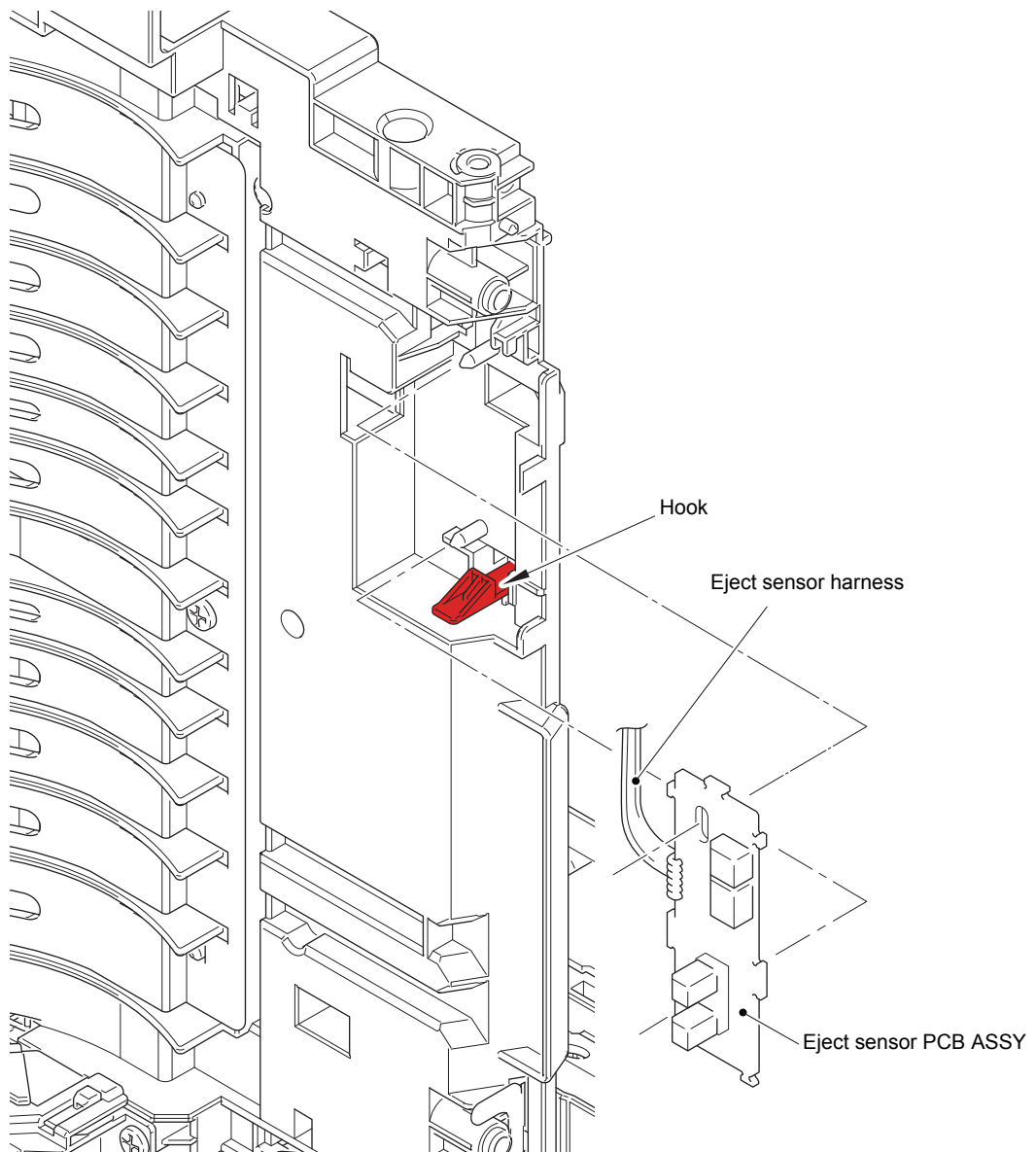

Fig. 3-112

Harness routing: Refer to ["12. Bottom side of the machine"](#).

9.41 MP roller holder ASSY / MP separation pad ASSY / MP separation pad spring

- (1) Open the MP roller cover. Release the hook on the MP holder bushing, and slide the MP holder bushing in the direction of the arrow 1.
- (2) Slide the MP roller holder ASSY in the direction of the arrow 2a to remove it from the MP separation roller shaft. Then push the MP lift arm in the direction of the arrow 2b to remove the MP roller holder ASSY.
- (3) Push the MP lift arm in the direction of the arrow 2b. Raise the MP separation pad ASSY to the 50-degree position, and remove it in the direction of the arrow 3.
- (4) Remove the MP separation pad spring.

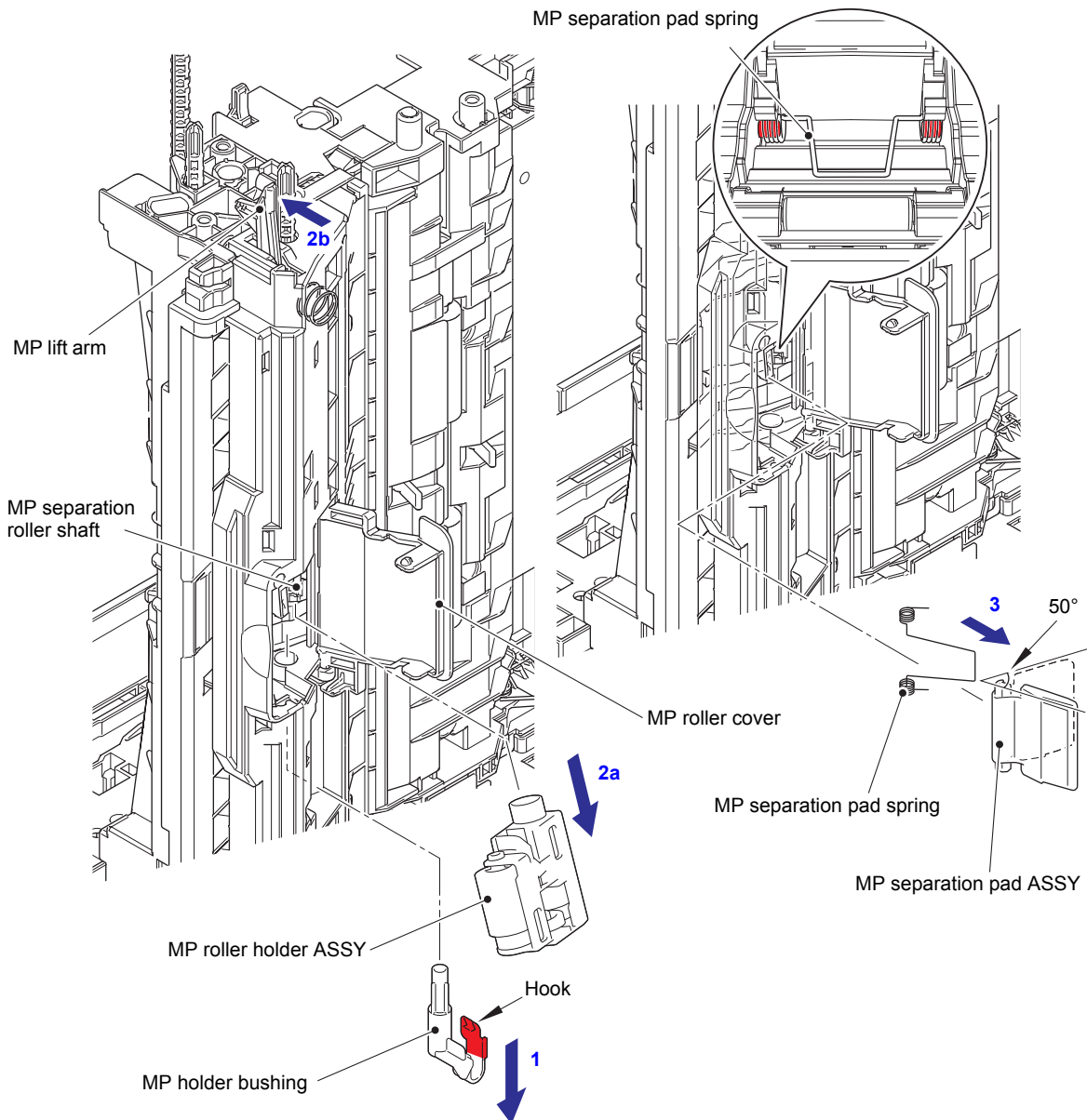

Fig. 3-113

Assembling Note:

- Attach the MP roller holder ASSY while pushing the MP separation pad ASSY.
- Attach the MP separation pad spring as described in the figure above.

9.42 T1 paper feed sensor PCB ASSY / T1 paper feed actuator / T1 paper feed actuator spring

- (1) Release the T1 paper feed sensor harness from the securing fixtures.
- (2) Remove the tapite bind B M3x10 screw, and remove the T1 paper feed actuator holder ASSY.
- (3) Remove the tray lock R.

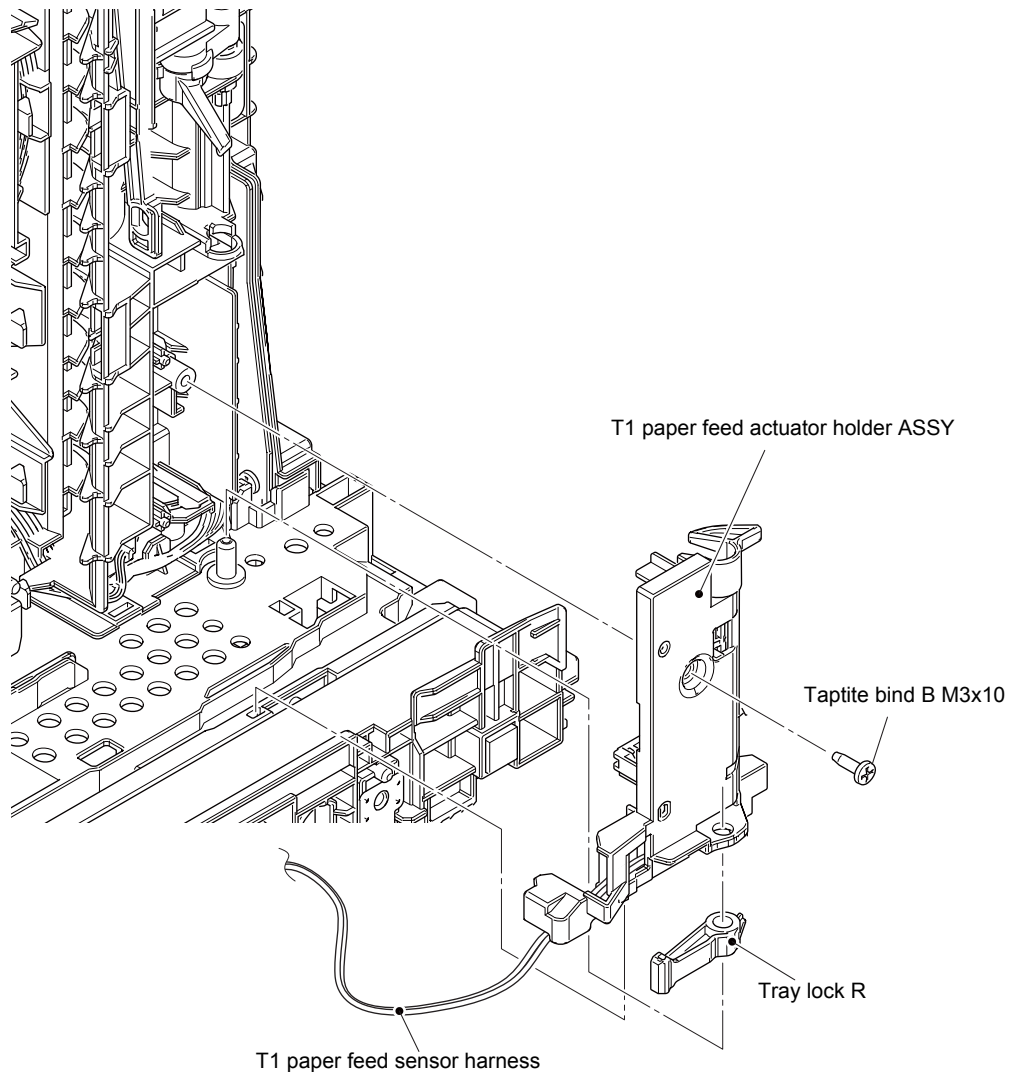

Fig. 3-114

Harness routing: Refer to ["13. Bottom side of the machine \(High-voltage power supply PCB ASSY\)"](#).

- (4) Turn the T1 paper feed actuator in the direction of the arrow 4a, and push the hook on the T1 paper feed actuator holder to slide the T1 paper feed actuator in the direction of the arrow 4b to remove it from the T1 paper feed actuator holder.
- (5) Remove the T1 paper feed actuator spring from the T1 paper feed actuator.
- (6) Remove the securing fixtures of the T1 paper feed sensor harness from the T1 paper feed actuator holder. Release the hook, and remove the T1 paper feed sensor PCB ASSY from the T1 paper feed actuator holder.

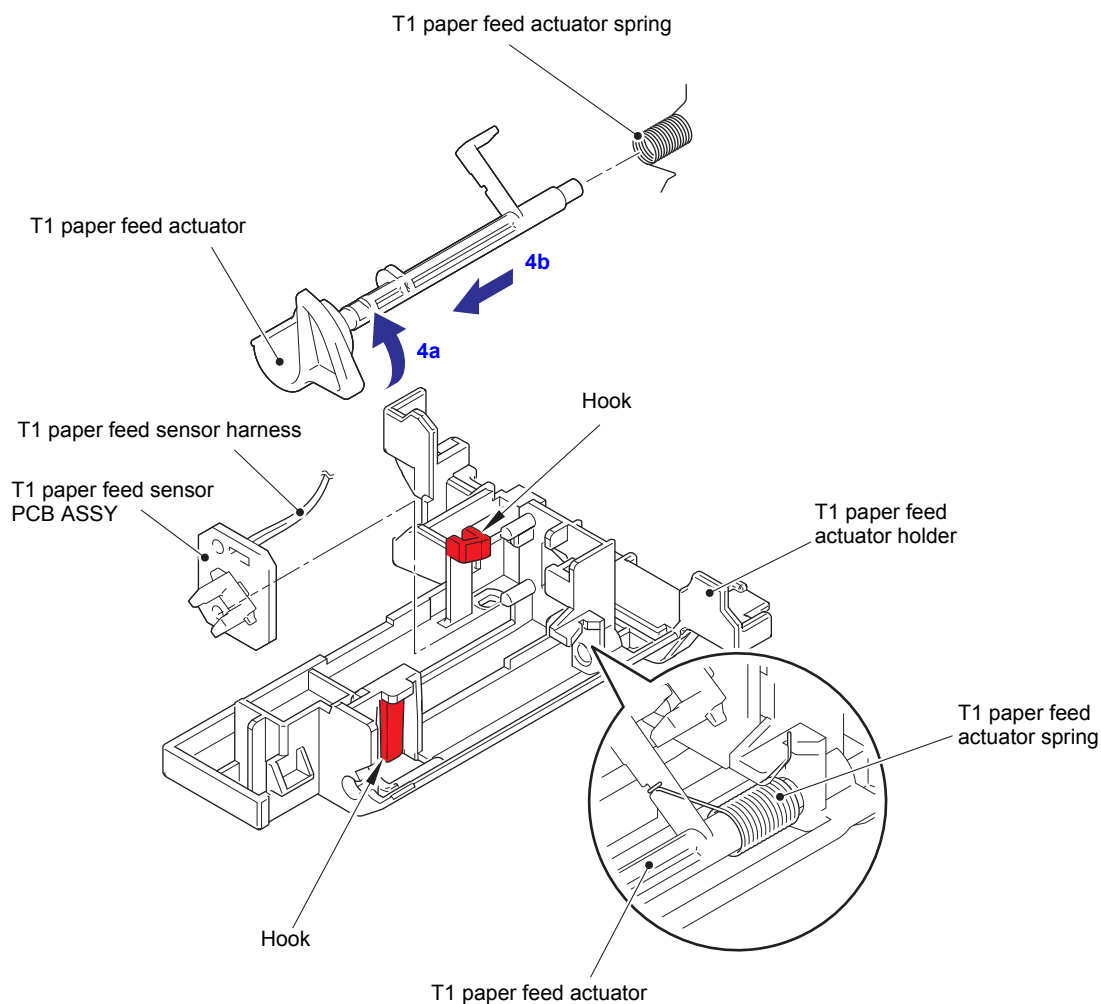

Fig. 3-115

Harness routing: Refer to [“13. Bottom side of the machine \(High-voltage power supply PCB ASSY\)”](#).

9.43 MP paper empty sensor PCB ASSY / MP paper empty actuator 1 / MP paper empty actuator 2

- (1) Remove the five taptite bind B M4x12 screws. Remove the main frame R from the paper feed frame ASSY, and pull out the low-voltage power supply harness from the hole of the main frame R.

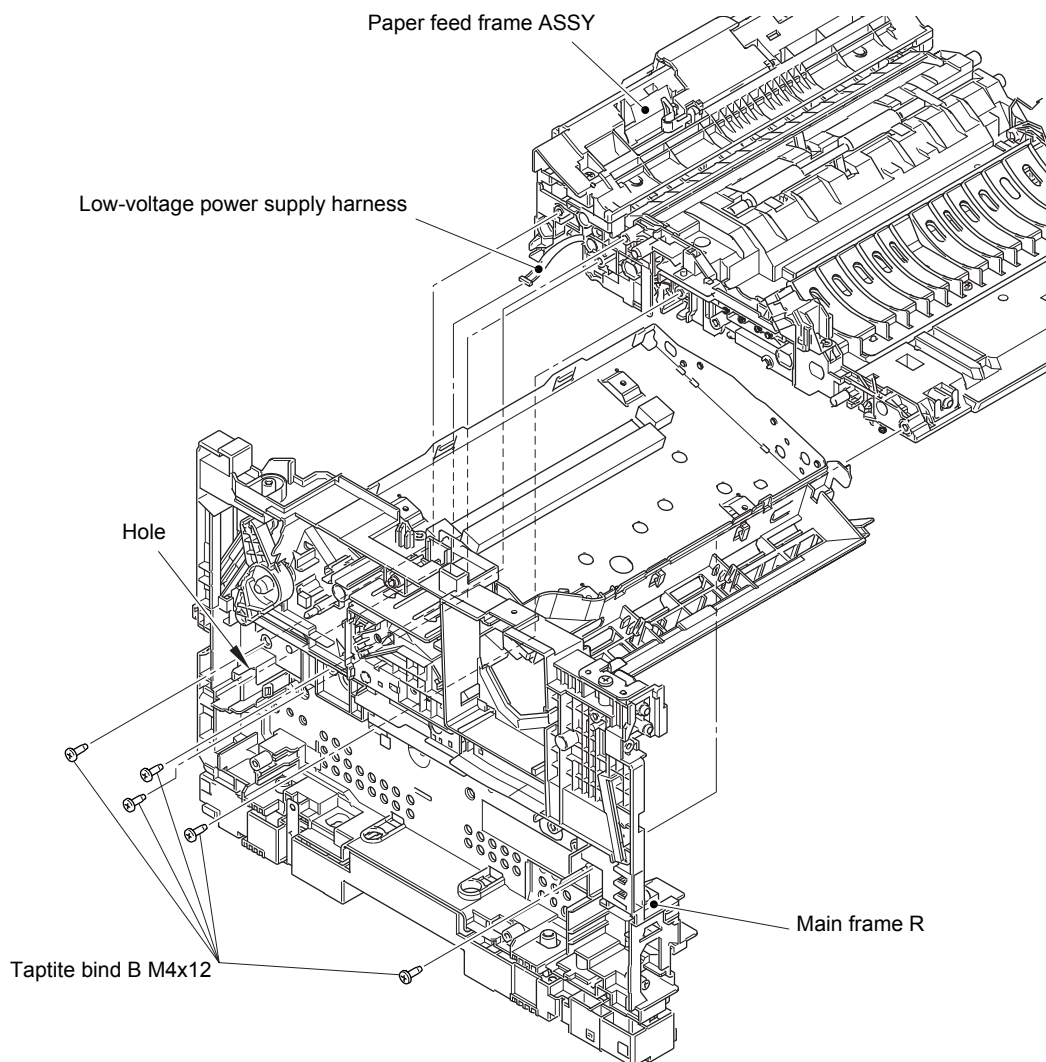

Fig. 3-116

- (2) Disconnect the securing fixtures of the MP paper empty sensor harness from the paper feed frame ASSY.
- (3) Remove the two Taptite bind B M3x10 screws. Release the two hooks, and remove the MP feed frame from the paper feed frame ASSY. Then pull out the MP paper empty sensor harness from hole of the paper feed frame ASSY.
- (4) Remove the MP lift arm spring from the paper feed frame ASSY.

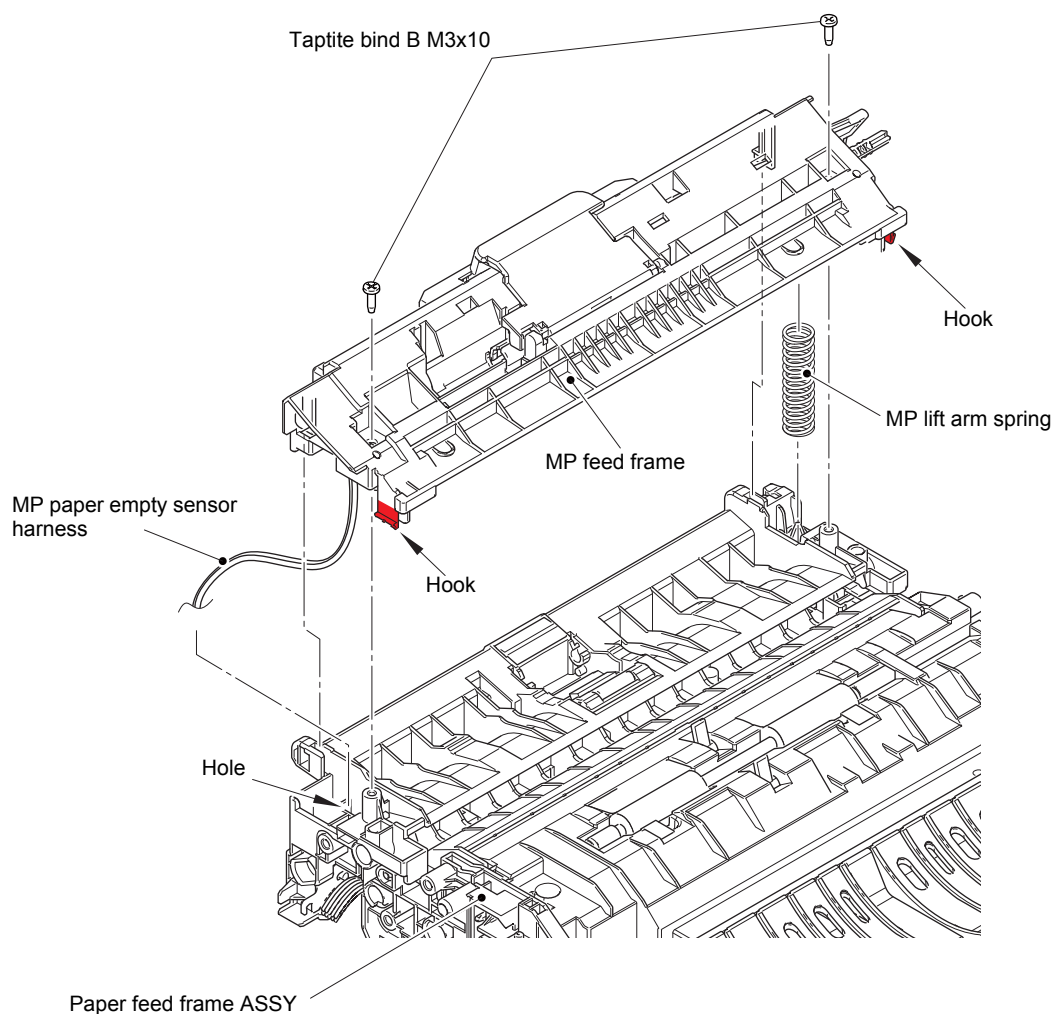

Fig. 3-117

Harness routing: Refer to **“13. Bottom side of the machine (High-voltage power supply PCB ASSY)”**.

- (5) Turn MP paper empty actuator 2 in the direction of the arrow 5a, and push the hook in the direction of the arrow 5b to slide MP paper empty actuator 1 in the direction of the arrow 5c to remove it from the MP feed frame in the direction of the arrow 5d.
- (6) Turn MP paper empty actuator 2 in the direction of the arrow 5a, and remove it from the MP feed frame in the direction of the arrow 6.
- (7) Remove the taptite bind B M3x10 screw. Remove the MP paper empty sensor PCB ASSY from the MP feed frame, and pull out the MP paper empty sensor harness from the hole.

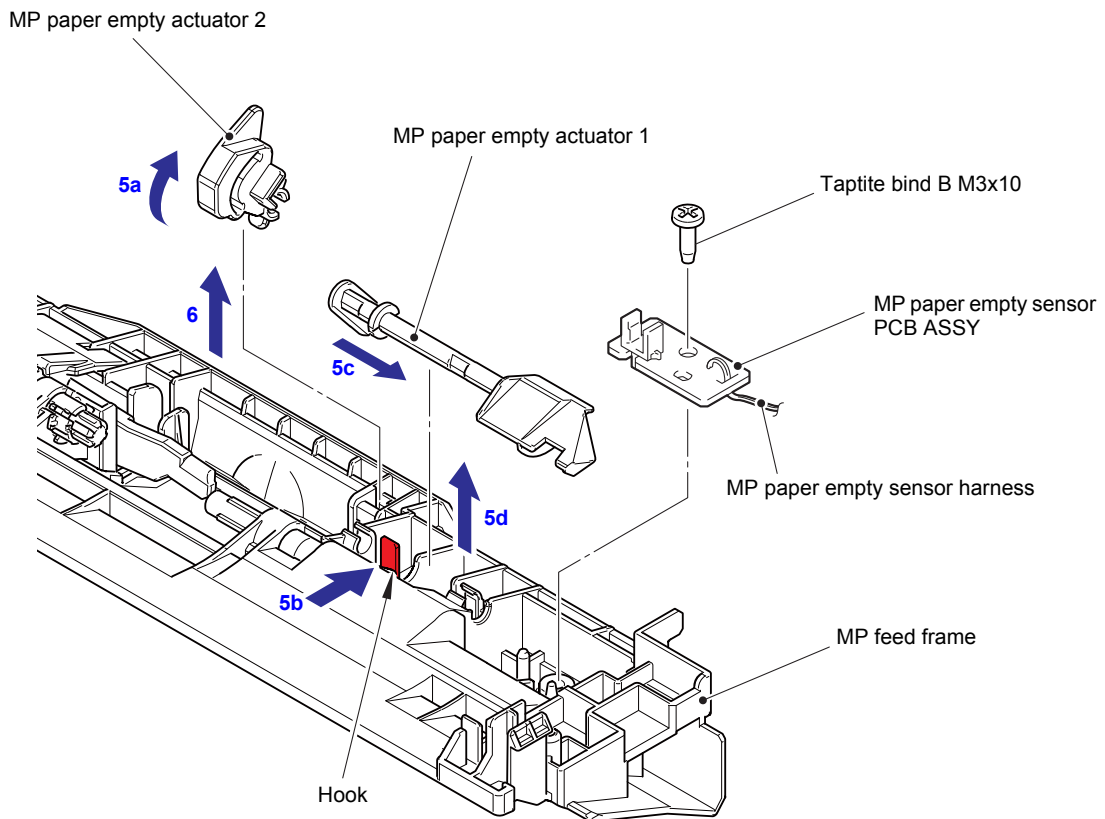

Fig. 3-118

Assembling Note:

- Insert the end of MP paper empty actuator 1 into the groove on the MP paper empty actuator 2.

9.44 Paper empty sensor PCB ASSY (Models with USB host on the rear side only)

- (1) Release the hook on the bushing, and pull out the separation roller shaft to remove the paper empty actuator.
- (2) Release the hook, and remove the paper empty actuator cover.
- (3) Remove the taptite bind B M3x10 screw, and remove the paper empty sensor PCB ASSY. Disconnect the paper empty sensor harness from the paper empty sensor PCB ASSY, and release the paper empty sensor harness from the securing fixtures.

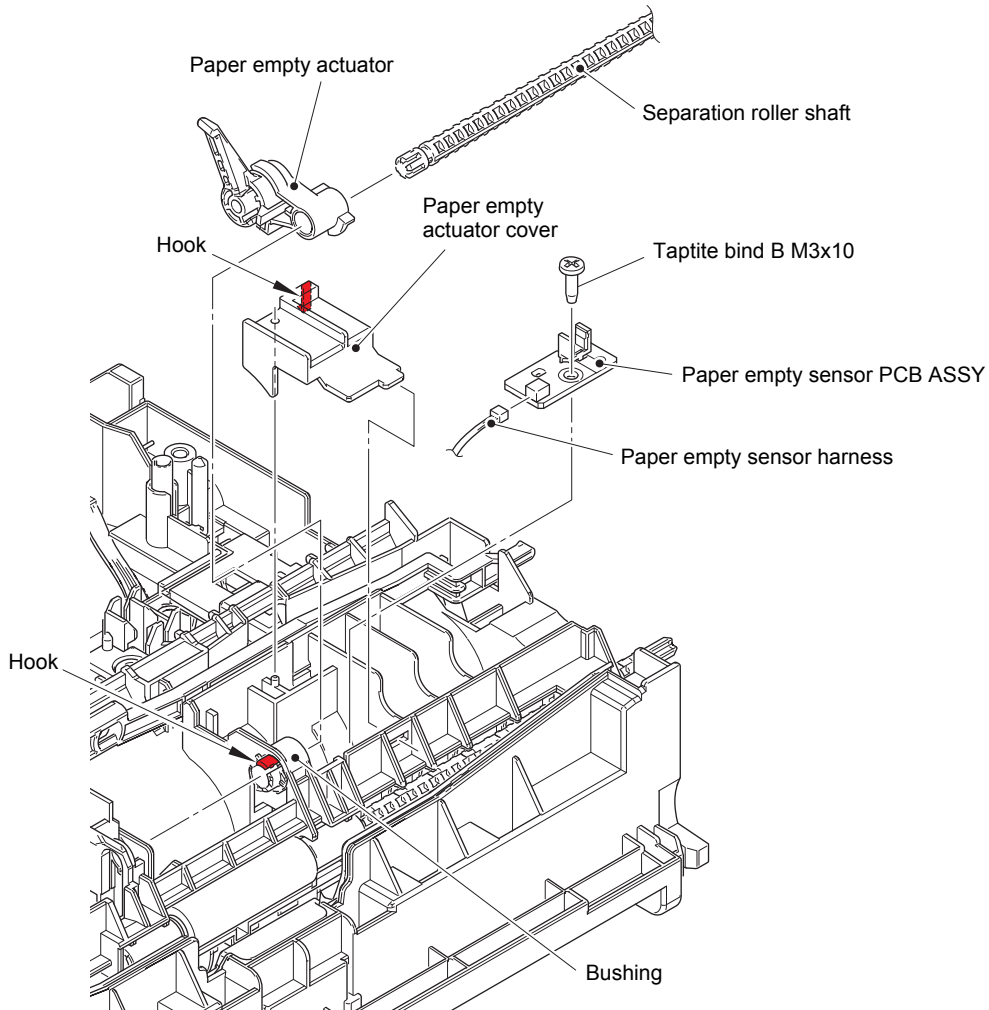

Fig. 3-119

Harness routing: Refer to ["12. Bottom side of the machine"](#).

9.45 Registration front/rear sensor PCB ASSY

- (1) Release the low-voltage power supply harness from the securing fixtures.
- (2) Release the two hooks, and remove the paper feed frame from the feed chute.

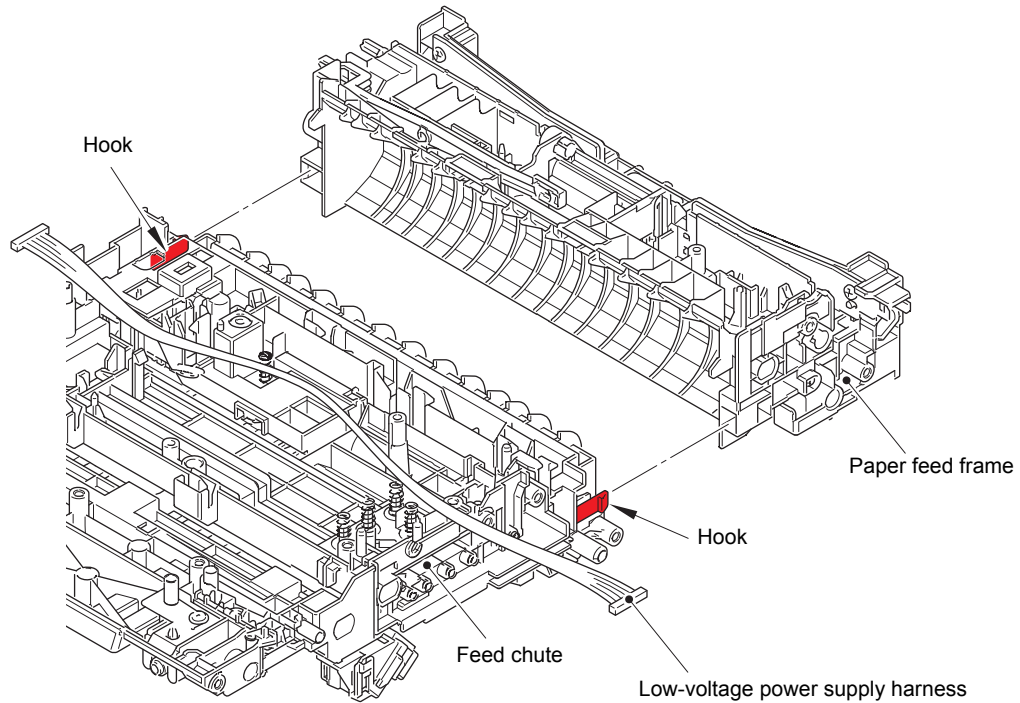

Fig. 3-120

Harness routing: Refer to ["12. Bottom side of the machine"](#).

- (3) Remove the ground registration spring from the hook A on the feed chute, and remove the ground registration spring from the feed chute.
- (4) Release the electrode TR from the hook B on the registration actuator holder ASSY, and remove the electrode TR from the registration actuator holder ASSY.
- (5) Release the hook C, and remove the registration actuator holder ASSY from the feed chute.

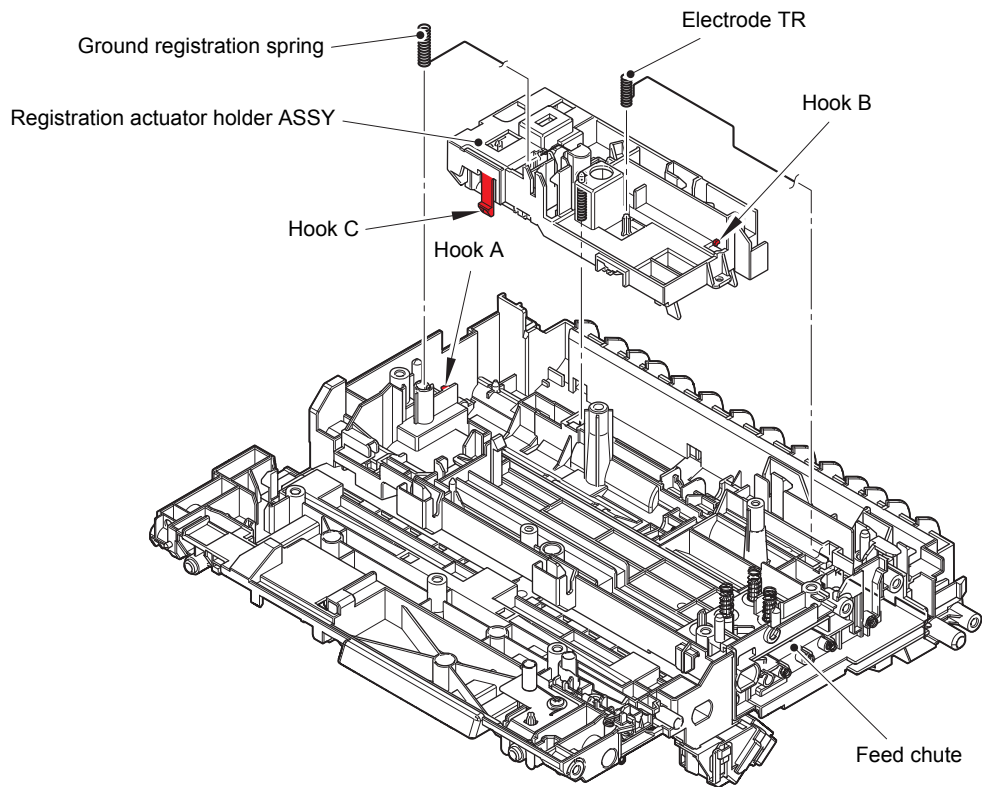

Fig. 3-121

- (6) Remove the registration actuator spring from the registration front actuator and the registration actuator holder ASSY.
- (7) Turn the registration front actuator to remove it from the guide, and then slide it in the direction of the arrow to remove it from the registration actuator holder ASSY.
- (8) Remove the registration actuator spring from the registration rear actuator and the registration actuator holder ASSY.
- (9) Turn the registration rear actuator to remove it from the guide, and then slide it in the direction of the arrow to remove it from the registration actuator holder ASSY.
- (10) Release the registration front/rear sensor harness from the securing fixtures. Release the hook, and remove the registration front/rear sensor PCB ASSY from the registration actuator holder ASSY.

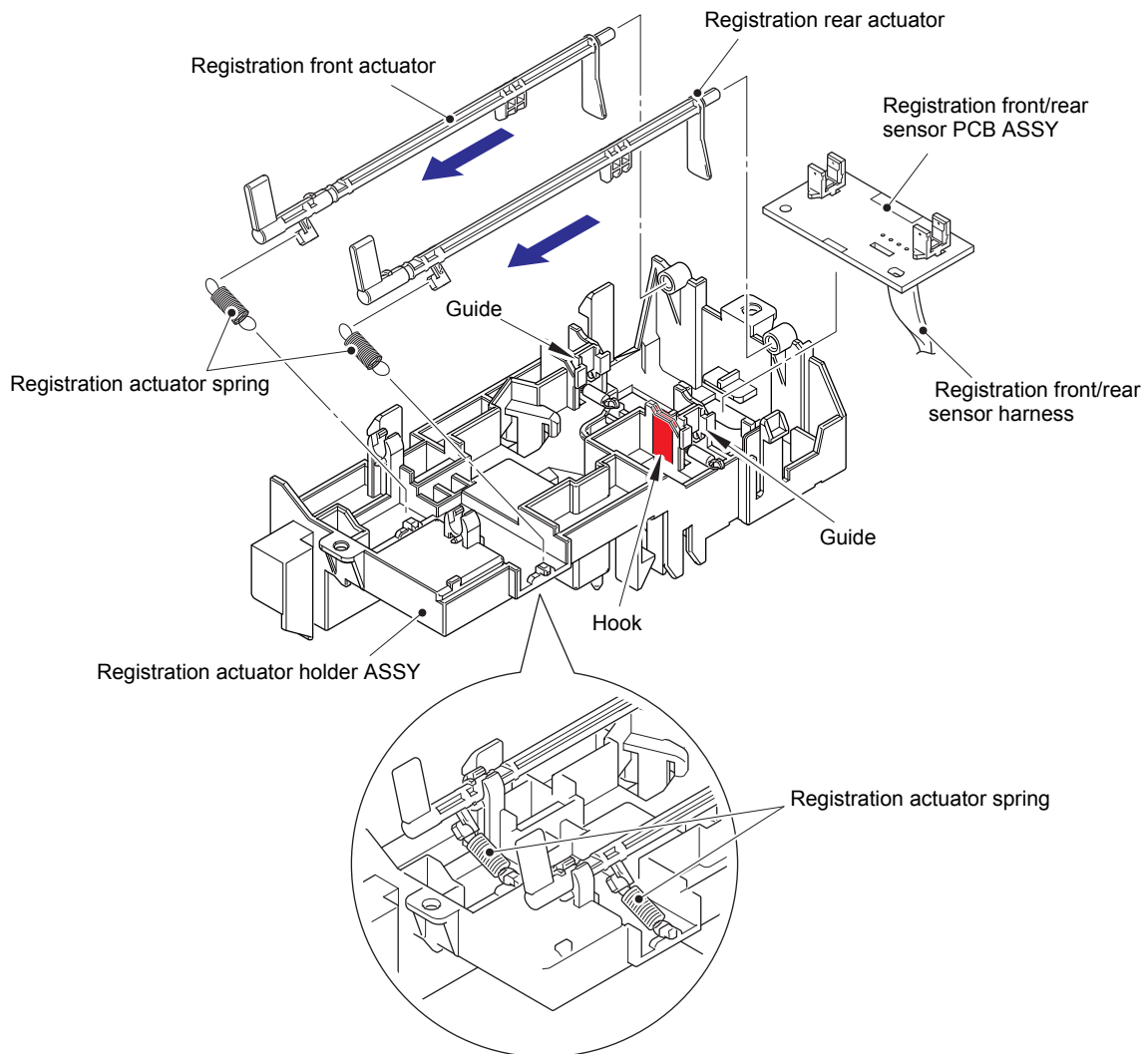

Fig. 3-122

Harness routing: Refer to “13. Bottom side of the machine (High-voltage power supply PCB ASSY)”.

Assembling Note:

- Attach the registration actuator spring on the position described in the figure above.

10. DISASSEMBLY PROCEDURE (LT UNIT)

10.1 Paper tray

- (1) Release the two hooks on the separation pad ASSY from the paper tray.
- (2) Push both side arms on the separation pad ASSY inwards to remove the pins, and remove the separation pad ASSY from the paper tray.
- (3) Remove the separation pad spring from the separation pad ASSY.

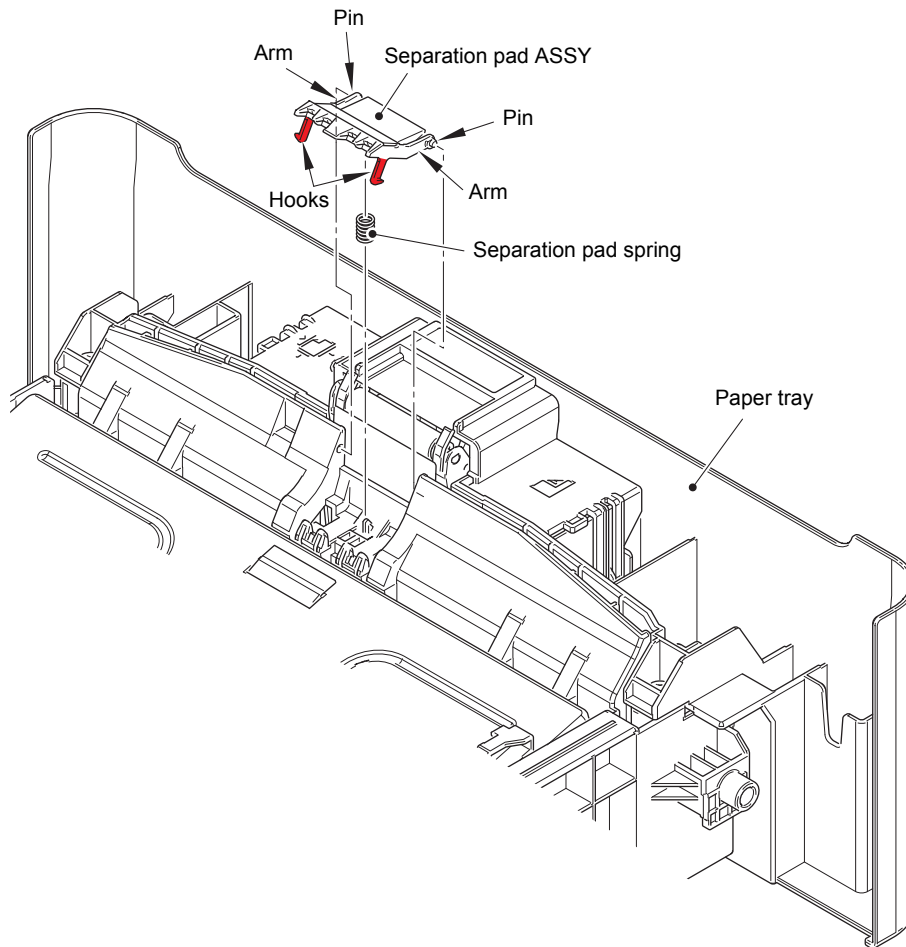

Fig. 3-123

- (4) Push the hook on the lift gear Z27M10 (or lift gear Z48M10) while lifting the plate-up plate, and remove the lift gear Z27M10 (or lift gear Z48M10) from the paper tray.
250-sheet: Lift gear Z27M10
520-sheet: Lift gear Z48M10
- (5) Remove the gear Z22M10 and the idle gear Z18M10 or 50 Z18M10 from the paper tray.
250-sheet: Idle gear Z18M10
520-sheet: Idle gear 50 Z18M10

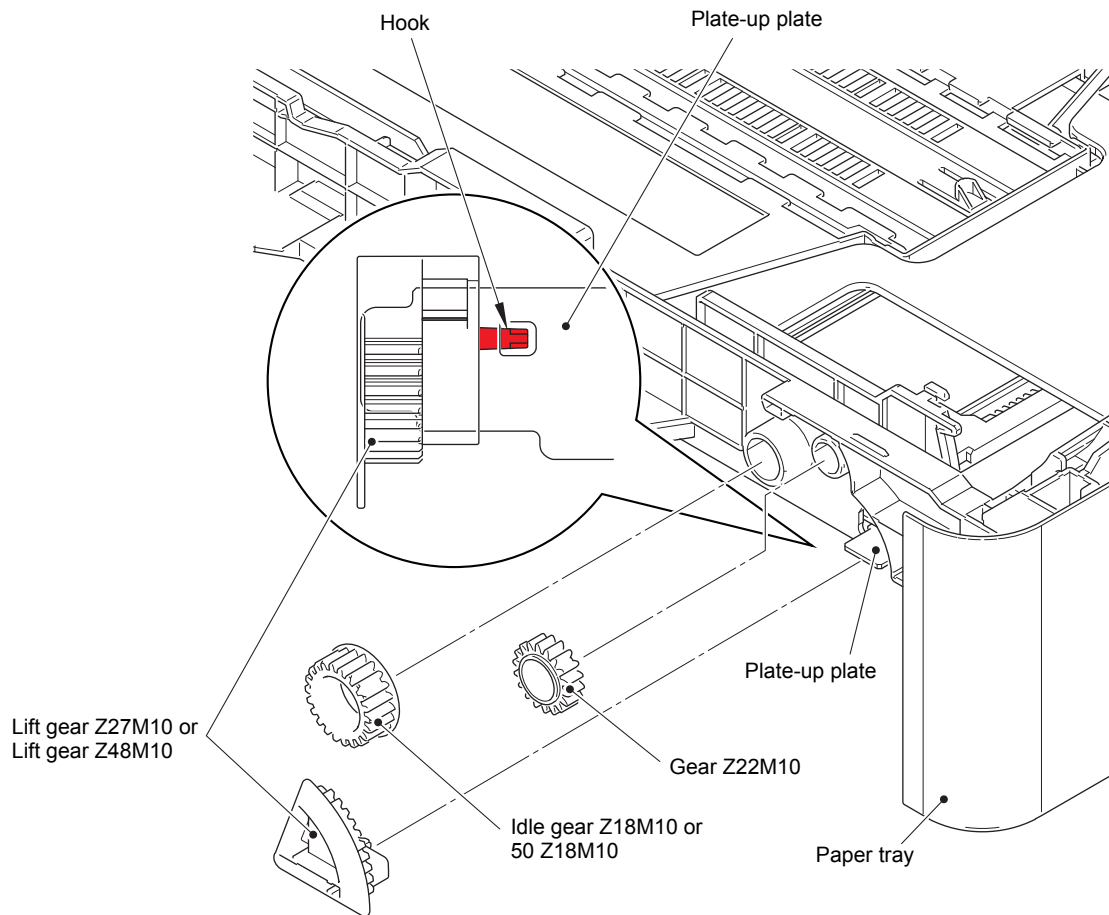

Fig. 3-124

10.2 LT roller holder ASSY

- (1) Push the link arm in the direction of the arrow A, and turn the LT roller holder ASSY to remove the boss.
- (2) Slide the LT roller holder ASSY in the direction of the arrow B to remove it from the shaft, and remove the LT roller holder ASSY.

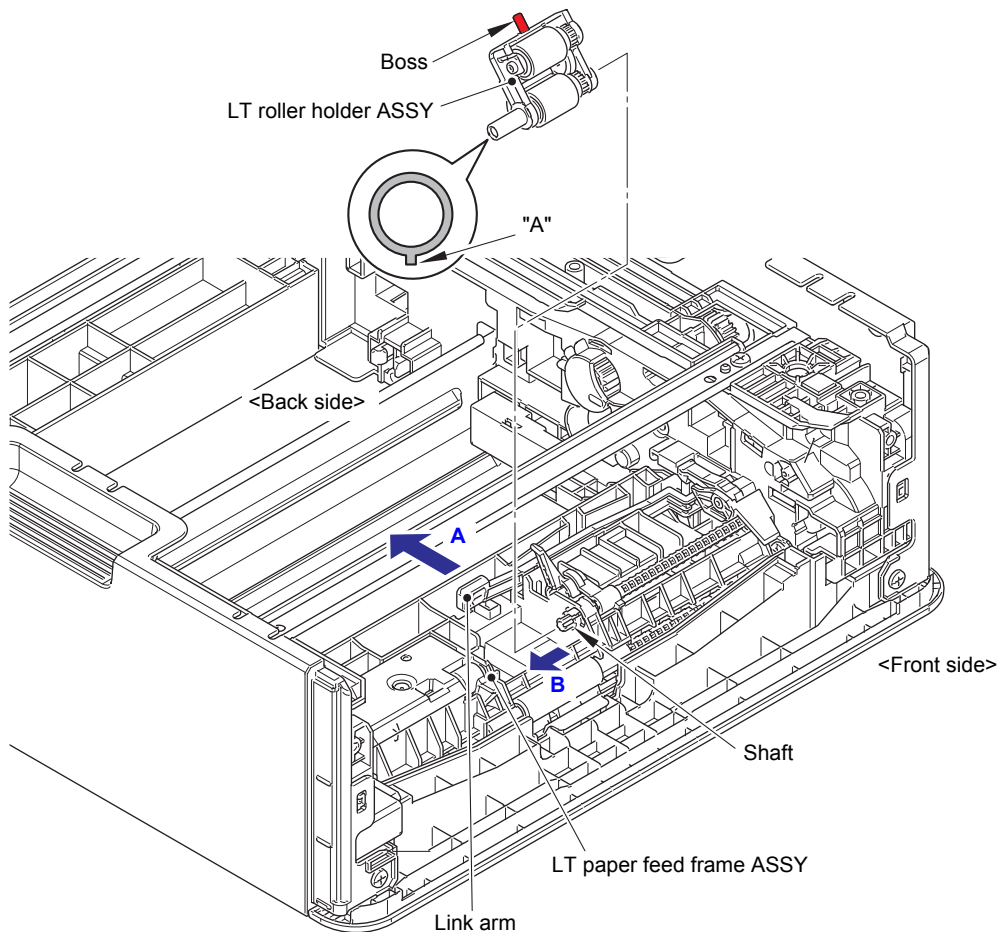

Fig. 3-125

Assembling Note:

- When attaching the LT roller holder ASSY, engage "A" on the shaft of the LT roller holder ASSY with the hole on the LT paper feed frame ASSY, and insert the shaft into the hole.

10.3 LT side cover L

- (1) Remove the two taptite bind B M4x12 screws. Release each hook, and remove the LT side cover L from the LT unit.

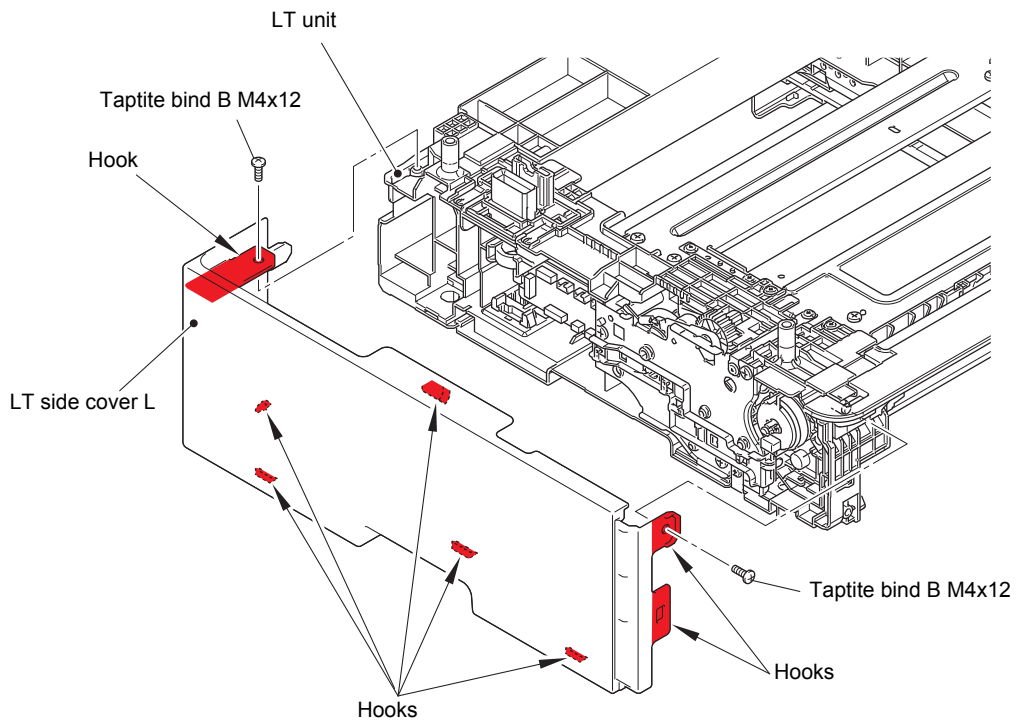

Fig. 3-126

10.4 LT side cover R

- (1) Remove the two taptite bind B M4x12 screws. Release each hook, and remove the LT side cover R from the LT unit.

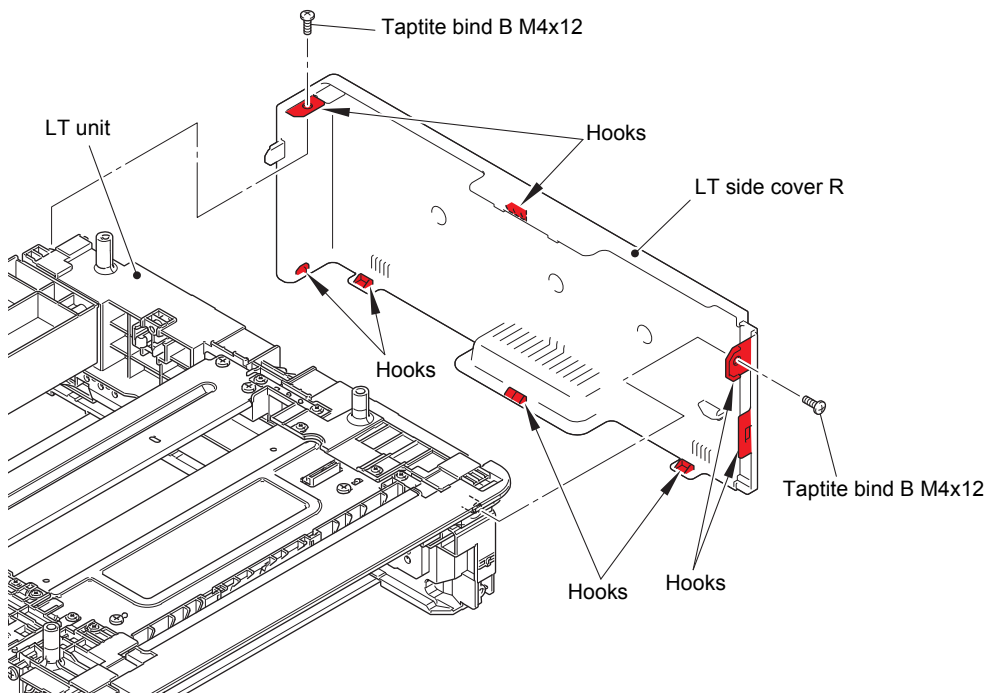

Fig. 3-127

10.5 LT front cover ASSY

- (1) Remove the taptite cup S M3x8 SR screw. Release the two hooks, and remove the LT front cover ASSY from the LT unit.

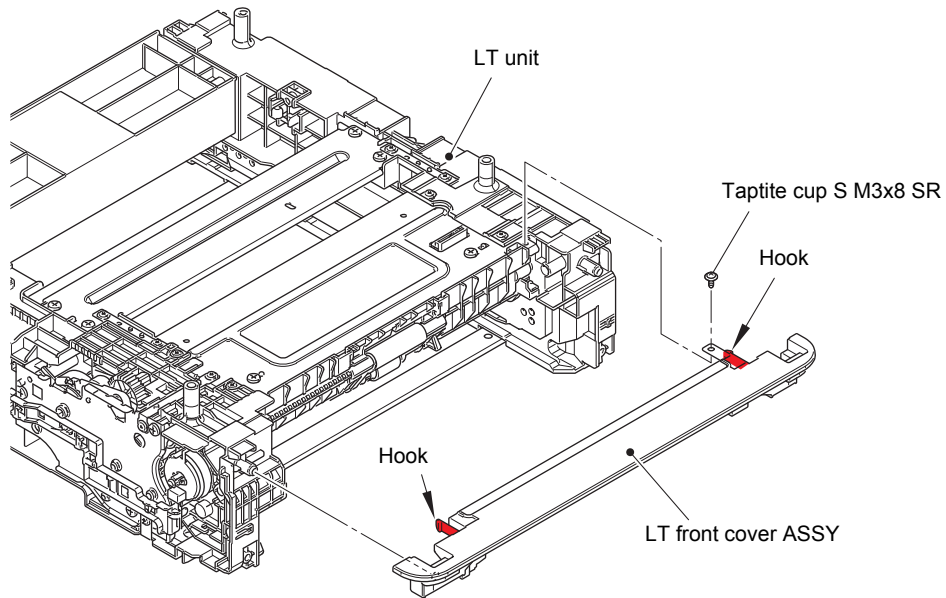

Fig. 3-128

10.6 LT control PCB ASSY

- (1) Disconnect all harnesses from the LT control PCB ASSY.

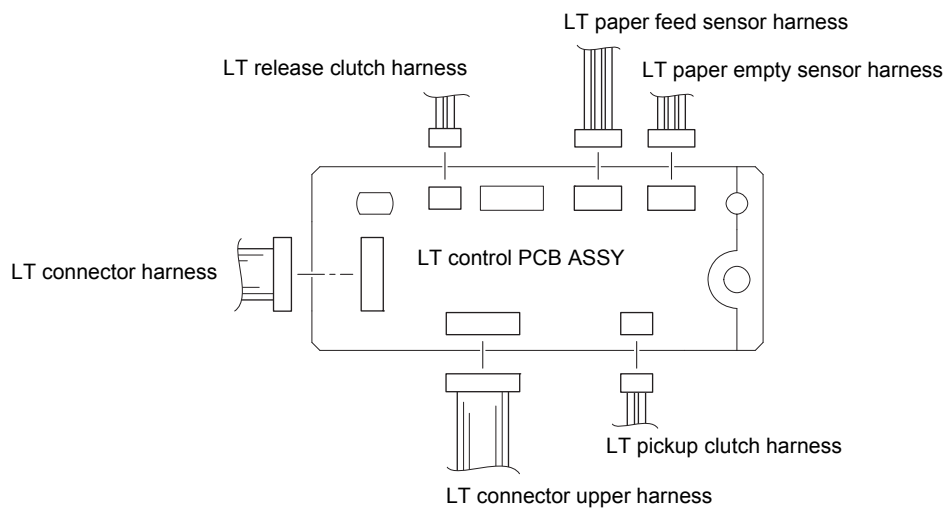

Fig. 3-129

- (2) Release the hook, and remove the LT control PCB ASSY from the LT unit.

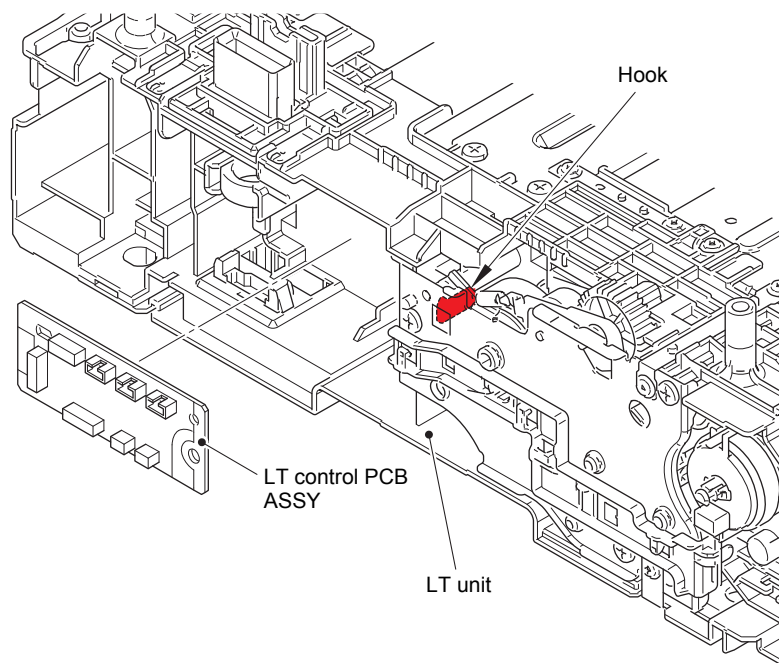

Fig. 3-130

10.7 LT pickup clutch

- (1) Release the LT pickup clutch harness from the securing fixtures. Release the hook, and remove the LT pickup clutch from the LT unit.

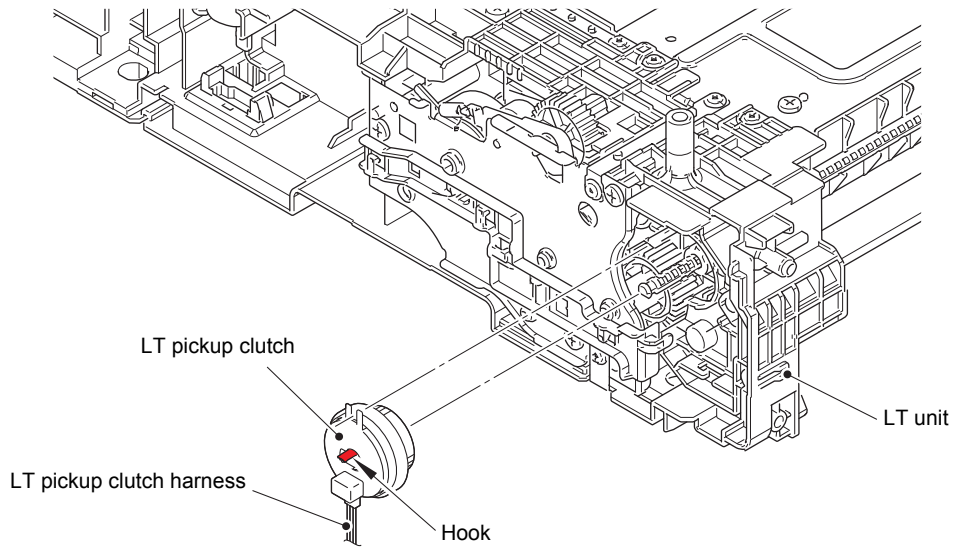

Fig. 3-131

10.8 LT release clutch

■ For models with 520-sheet

- (1) Remove the two taptite bind B M4×12 screws, and remove the under bar front.
- (2) Remove the taptite cup S M3×8 SR screw, and remove the under bar ground plate L (520).

■ For models with 250-sheet

- (3) Remove the two taptite bind B M4×12 screws and two taptite cup S M3×8 SR screws (3a) (3b) to remove the under bar front.

■ Common to all models

- (4) Remove the two taptite bind B M4×12 screws, and remove the under bar.

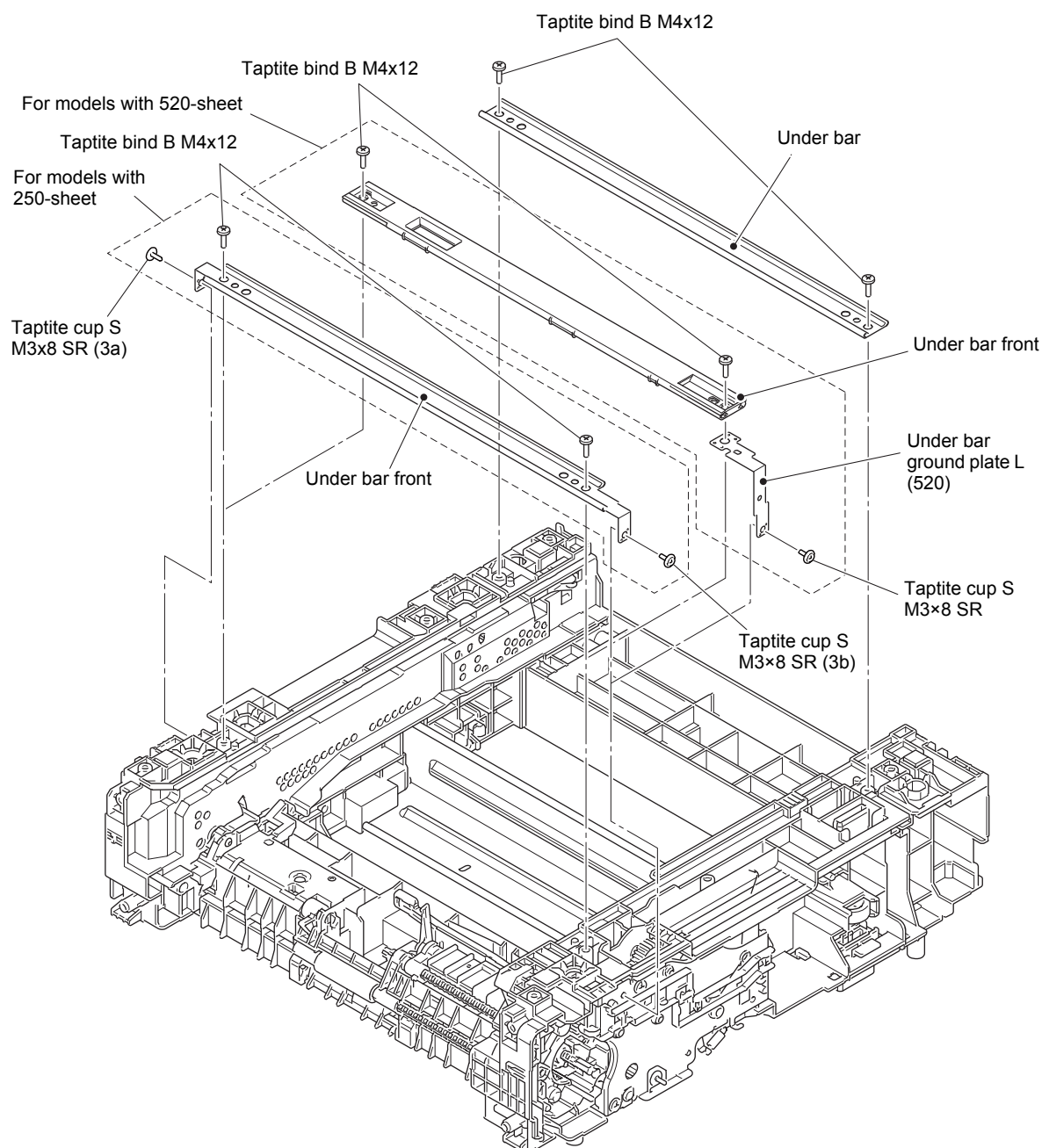

Fig. 3-132

- (5) Remove the two taptite cup S M3x8 SR screws (5a) (5b), and remove the center FG plate L from the LT frame L unit.
- (6) Remove the two taptite cup S M3x8 SR screws, and remove the under bar ground plate L (250) from the LT frame L unit.
- (7) Remove the four taptite bind B M4x12 screws and six taptite cup S M3x8 SR screws (7a) (7b). Remove the LT frame L unit, and disconnect the two harnesses from the LT frame L unit.

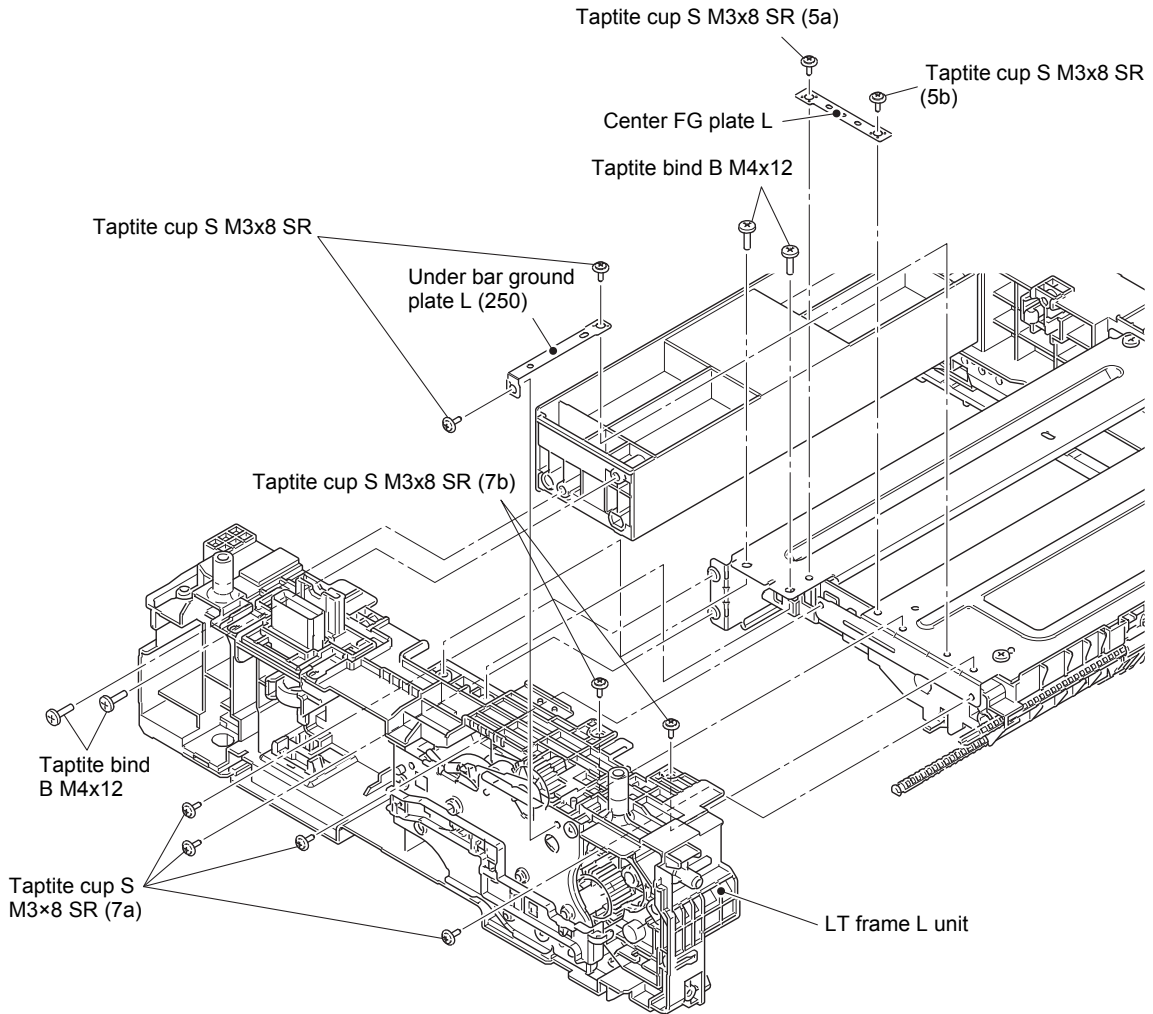

Fig. 3-133

- (8) Release the LT release clutch harness from the securing fixtures.
- (9) Remove the three taptite bind B M4x12 screws. Remove the LT drive ASSY from the LT frame L unit, and pull out the LT release clutch harness from the hole.
- (10) Remove the LT release clutch from the LT frame L unit.
- (11) Remove the LT clutch shaft and LT gear 22 from the LT release clutch.

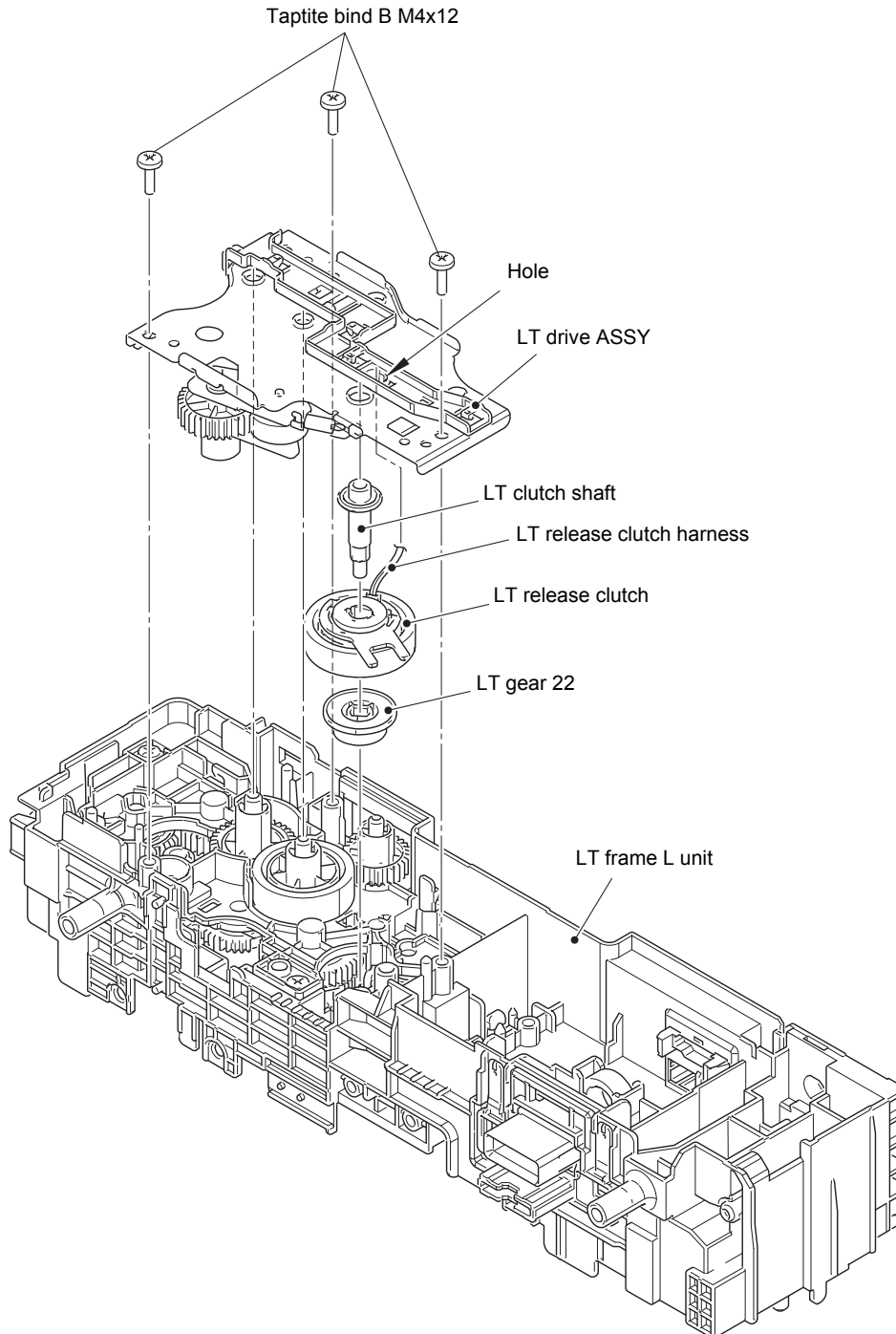

Fig. 3-134

10.9 LT connector ASSY / LT connector upper

- (1) Release the hook, and remove the core from the LT frame L unit.
- (2) Release the two hooks A, and slide the LT connector ASSY in the direction of the arrow to remove it from the LT frame L unit.
- (3) Release the two hooks B to disconnect the LT connector harness from the LT connector ASSY.
- (4) Release the two hooks C, and remove the LT connector upper from the LT frame L unit.
- (5) Release the two hooks D to disconnect the LT connector upper harness from the LT connector upper.

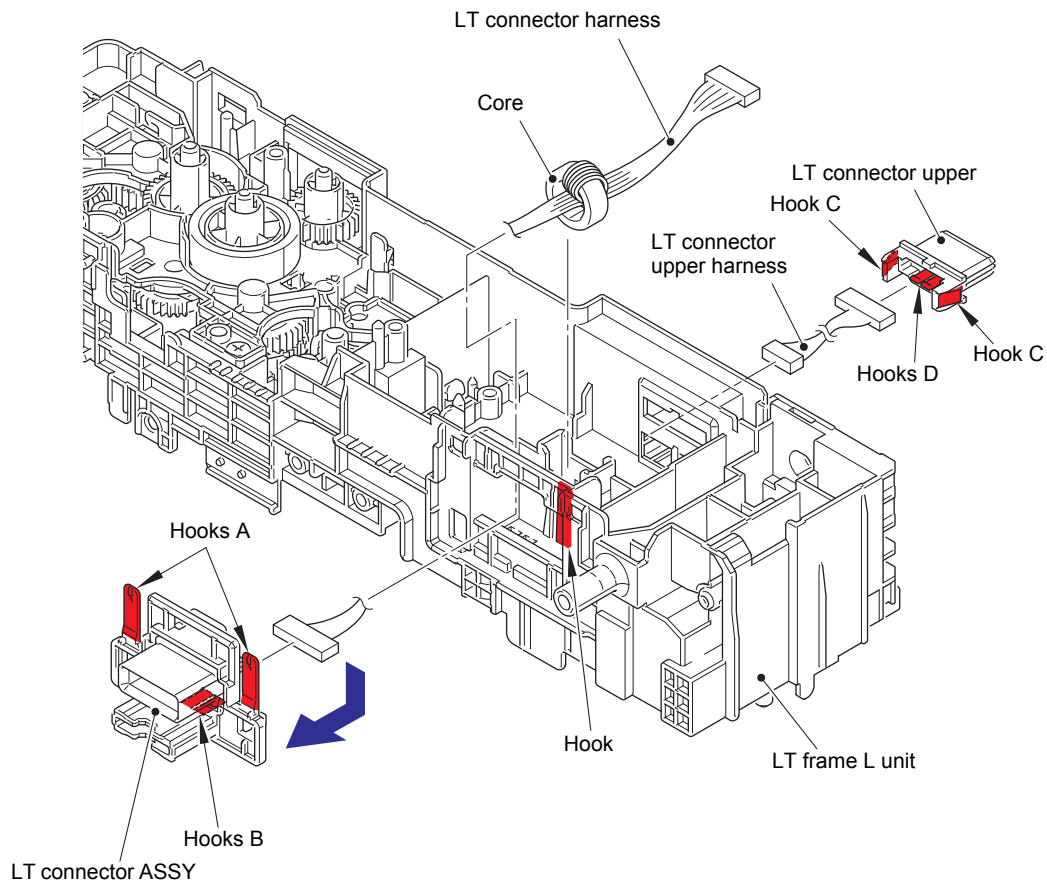

Fig. 3-135

10.10 LT paper feed sensor PCB ASSY

- (1) Remove the two taptite cup S M3x8 SR screws (1a) (1b), and remove the center FG plate R from the LT frame R unit.
- (2) Remove the five taptite cup S M3x8 SR screws, and remove the paper feed frame FG plate R and LT paper feed frame from the LT frame R unit.

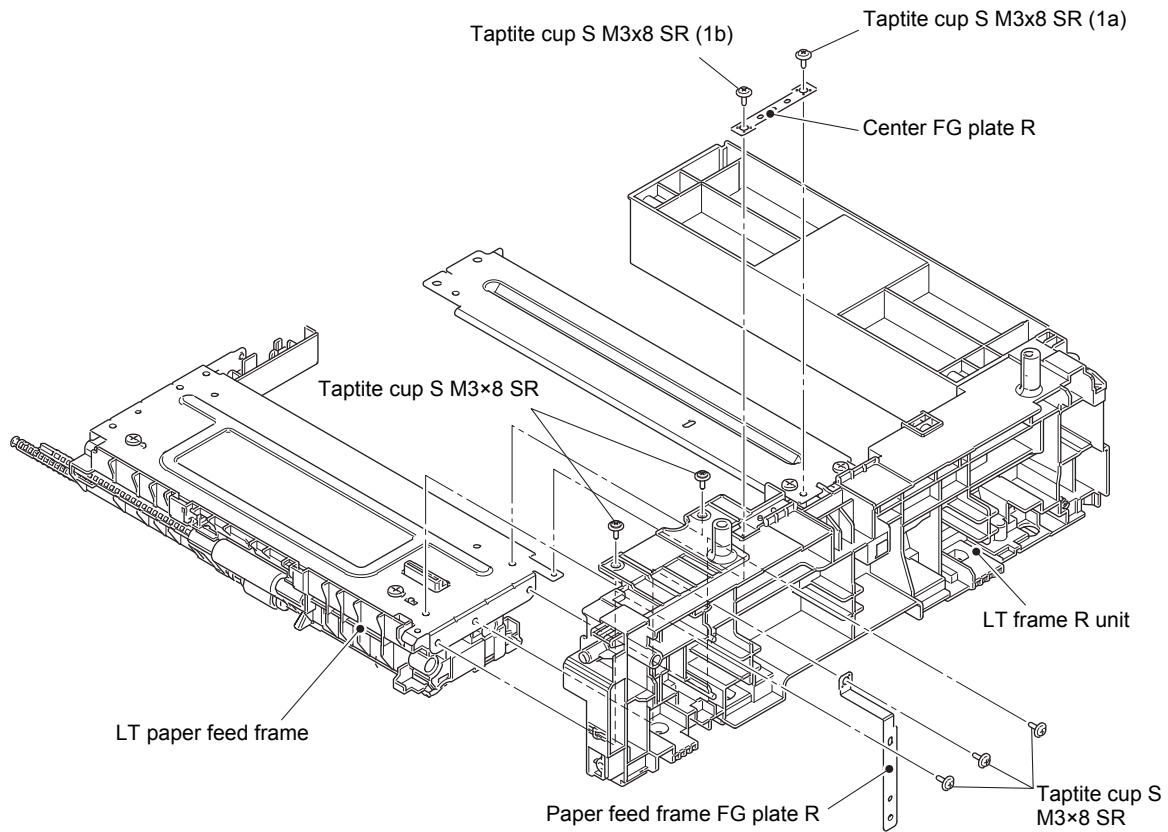

Fig. 3-136

- (3) Remove the two taptite bind B M4x12 screws, and remove the LT front beam from the LT paper feed frame ASSY.
- (4) Release the LT paper feed sensor harness from the securing fixtures.

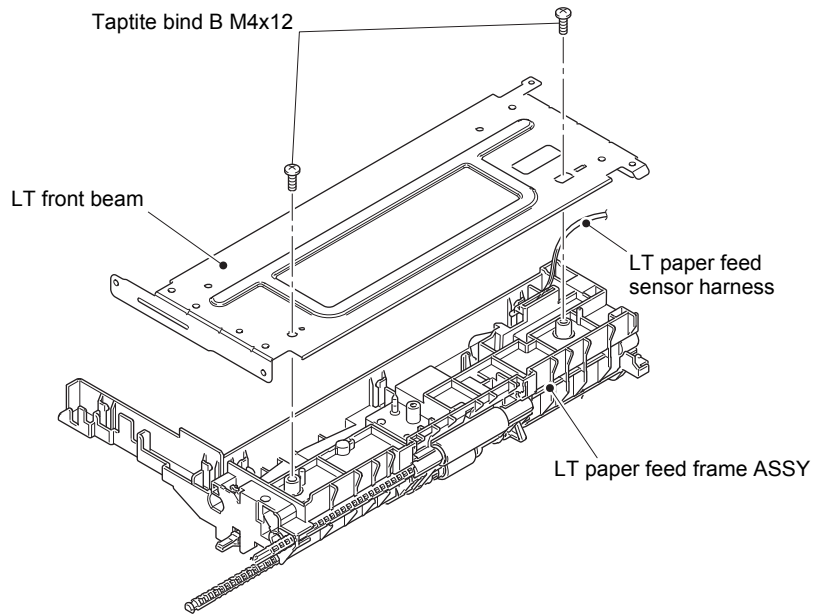

Fig. 3-137

- (5) Remove the taptite bind B M3x10 screw, and remove the LT paper feed actuator holder ASSY from the LT paper feed frame ASSY. Disconnect the LT paper feed sensor harness from the LT paper feed frame ASSY.

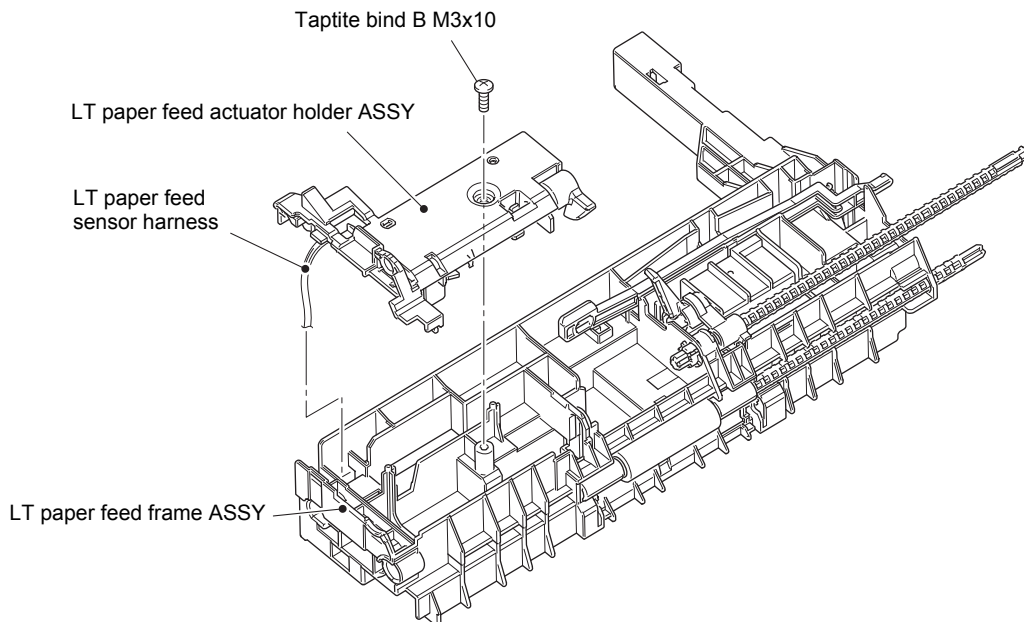

Fig. 3-138

- (6) Turn the LT paper feed actuator in the direction of the arrow A, and push the hook on the LT paper feed actuator holder ASSY to slide the LT paper feed actuator in the direction of the arrow B to remove it from the LT paper feed actuator holder ASSY.
- (7) Remove the LT paper feed actuator spring from the LT paper feed actuator.
- (8) Disconnect the securing fixtures of the LT paper feed sensor harness from the LT paper feed actuator holder ASSY, and then release the hook to remove the LT paper feed sensor PCB ASSY from the LT paper feed actuator holder ASSY.

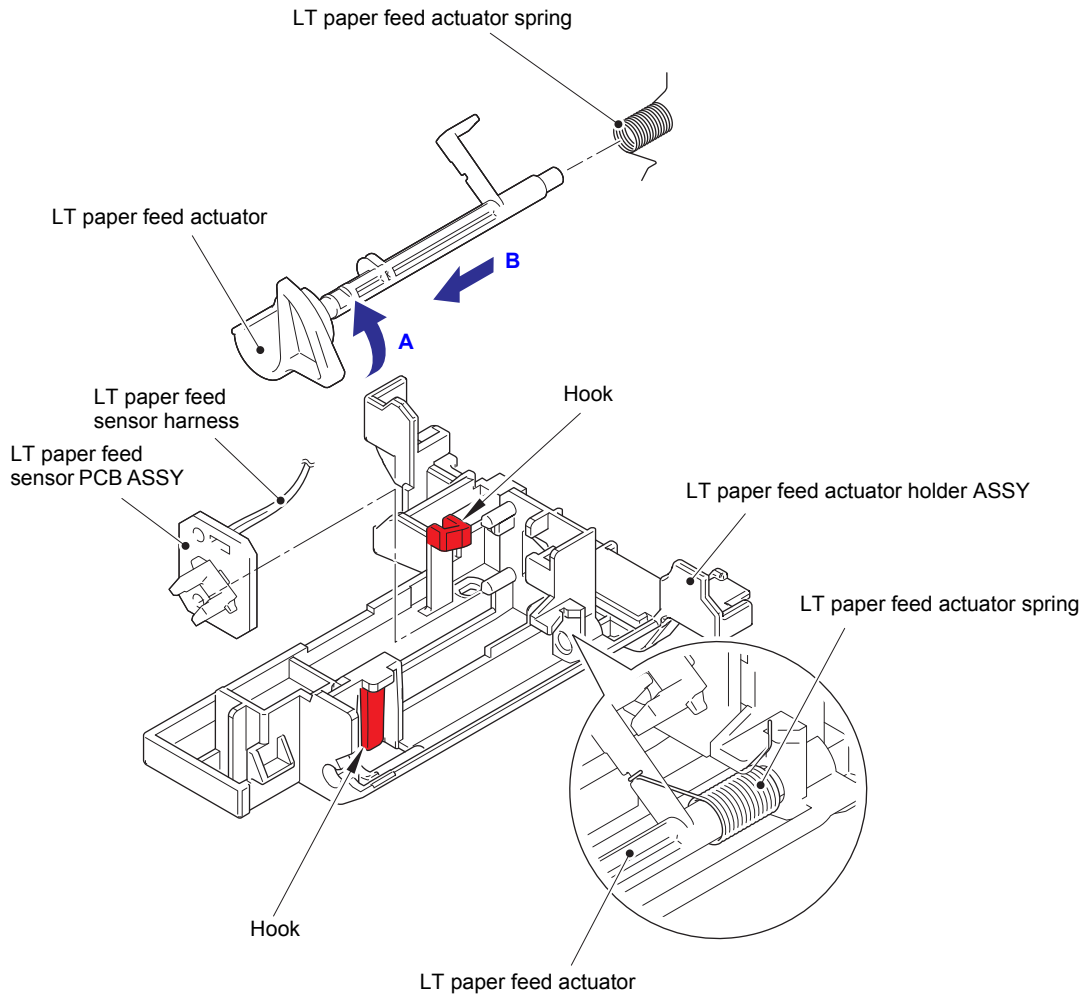

Fig. 3-139

10.11 LT paper empty sensor PCB ASSY

- (1) Release the hook on the bushing, and pull out the LT separation roller shaft to remove the LT paper empty actuator.
- (2) Release the hook, and remove the LT paper empty actuator cover.
- (3) Release the LT paper empty sensor harness from the securing fixtures.
- (4) Remove the taptite bind B M3x10 screw, and remove the LT paper empty sensor PCB ASSY.

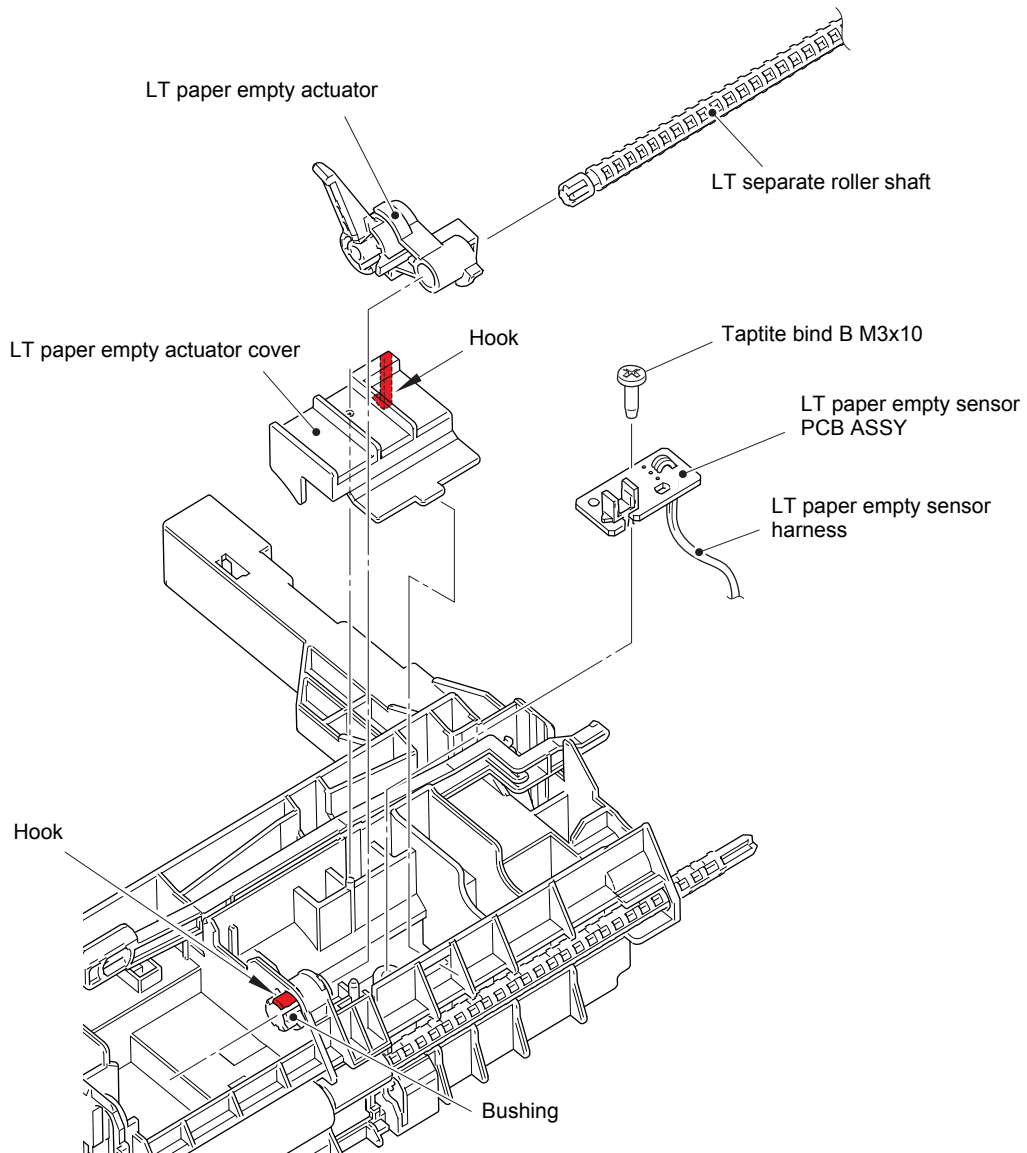

Fig. 3-140

CHAPTER 4 ADJUSTING AND UPDATING SETTINGS AS REQUIRED AFTER PARTS REPLACEMENT

1. IF YOU REPLACE THE MAIN PCB ASSY

■ What to do after replacement

- Installing Firmware (Sub Firmware and Main Firmware)
- Adjusting Touch Panel (Function Code: 61)
- Initializing the EEPROM of the Main PCB ASSY (Function Code: 01)
- Configure for Country/Region and Model (Function Code: 74)
- Activating Memory Writing
- Setting Serial Number and Entering Adjusted Value of Laser Unit
- Acquiring White Level Data (Function Code: 55)
- Adjusting Left-end and Upper-end Print Position (Function Code: 45) (TT only)
- Resetting to Factory Shipping State

■ What you need to prepare

- (1) One USB cable
- (2) Create a temporary folder on the C drive of the computer (Windows® XP or later).
- (3) Service setting tool (BrUsbsn.zip)
Copy this file into the temporary folder created on the C drive. Extract the copied file.
- (4) Download utility (FILEDG32.EXE)
Copy this file into the temporary folder created on the C drive.
- (5) Maintenance driver (MaintenanceDriver.zip)
When the maintenance driver is not installed on the computer, copy this file into the temporary folder created on the C drive, and extract the copied file. Refer to “[APPENDIX 3 INSTALLING THE MAINTENANCE PRINTER DRIVER](#)” for the installation procedure.
- (6) Firmware

Sub firmware (PCL/PS-compliant model only)	djf file (ex. D001G9_A.djf)
Main firmware	

- (7) USB flash memory
- (8) Touch pen
- (9) Memory access tool (MemoryAccessTool.exe)
- (10) Shipping tool (ShippingTool.exe)

1.1 Installing Firmware (Sub Firmware and Main Firmware)

1.1.1 Checking firmware version

Check whether the firmware installed on the machine is the latest version. If it is the latest version, there is no need to install the firmware. If it is not, be sure to install the firmware to the machine as described in "1.1.2 Installing firmware".

<How to check firmware version>

- (1) Press and hold the [Home] key for approximately five seconds while the machine is in the ready state. Press the blank field at the bottom. Press the [*], [2], [8], [6], and [4] key on the LCD in this order, and the machine enters into maintenance mode.
- (2) Press the [2], and then the [5] key in the initial state of maintenance mode. "MAIN:Ver*. ** (#)" is displayed on the LCD.
- (3) Change the displayed item by pressing the [Mono Start] key to check all firmwares.
- (4) When you press the [X] key, this operation is finished and the machine returns to the initial state of maintenance mode.

Memo:

- You can also check the sub firmware and main firmware versions by implementing "Print maintenance information (function code: 77)" (refer to "1.3.25 Print maintenance information (function code: 77)" in Chapter 5).

1.1.2 Installing firmware

Note:

- TT and LT have their own firmware respectively. They are included in the main firmware. When connecting the options to the machine and turning on the power switch, the firmwares of these options will be updated with the main firmware version of the machine.

Memo:

- Do not disconnect the power cord, USB flash memory or USB cable from the machine or computer during installing.
- If the installation is failed, turn OFF the machine and turn it back on. The machine enters the firmware install mode automatically. Continue the operation procedure below.
- Firmware installation using USB flash memory is inoperable when the machine is in deep sleep mode. Release the deep sleep mode by opening / closing the front cover before the operation.
- Be sure to reinstall the sub firmware and then the main firmware in this order.
- When the firmware installation using USB flash memory is failed and the error message or no character appears on the LCD, refer to "Firmware installation using PC" in this chapter to install firmware using PC.

<Operating Procedure>

■ Firmware installation using USB flash memory

- (1) Create and save a file for automatic firmware update (file name: "_@\$UPD\$OP0.8080") under the USB flash memory.
- (2) Create the "FIRM" folder under the USB flash memory, and save the program file needed for firmware install (ex: D001G9_A.djf) in the "FIRM" folder.
- (3) Connect the USB flash memory to the USB flash memory port at the side of the machine while the machine is in the ready state. "Program Updating.Do not turn off." appears on the LCD and installation starts automatically. Back light goes off.
- (4) When installing is completed, the machine restarts automatically and "Completed..." appears on the LCD. Remove the USB flash memory. If multiple program files are saved in the USB flash memory, other installations start automatically after the restart. If the installation fails, "Unable to Update:*****" appears on the LCD. ("*****" indicates the error code.) Refer to the remedy and eliminate the error. Then reboot the machine and start from the procedure (1).

Error display	Description	Remedy
Unable to Update:0001	Memory full (Failed to secure the work area for update.)	Delete some data saved in the machine and install again.
Unable to Update:0002	No folder is specified	Save the firmware in the root folder (just below the USB flash memory).
Unable to Update:0003	Specified folder does not have a file	
Unable to Update:0004	File access failure	Change the USB flash memory and install again.
Unable to Update:0005	File data parsing error	Acquire the firmware from the data bank again.
Unable to Update:0006	File name has exceeded the character limit	Shorten the file name to be less than 119 Byte.
Unable to Update:0007	Unsupported DJF file detected	Acquire the firmware from the data bank again.
Unable to Update:0008	Other function is in use	Perform it again after finishing the running function.

■ Firmware installation using PC

- (1) Disconnect the USB cable if the machine is connected to your computer with it to enter the maintenance mode. (Refer to “1.1 How to Enter Maintenance Mode” in Chapter 5.)
- (2) Connect the machine to your computer using the USB cable.
- (3) Open the temporary folder and double-click "FILEDG32.EXE" to start it, and select "Brother Maintenance USB Printer".
- (4) Drag and drop the required program file (ex. DXXXXX_\$.djf) in the same folder onto the "Brother Maintenance USB Printer" icon in the Filedrgs screen. The file is loaded to the machine, and installing to the flash ROM starts.
- (5) When installing is completed, the machine restarts and returns to the ready state automatically.
- (6) Turn OFF the power switch of the machine, and then repeat the procedures (1) to (5) to install required firmwares.
- (7) Turn OFF the power switch of the machine, and disconnect the USB cable.

1.2 Adjusting Touch Panel (Function Code: 61)

Adjust the touch panel as described in “1.3.19 Adjust touch panel (function code: 61)” in Chapter 5.

1.3 Initializing the EEPROM of the Main PCB ASSY (Function Code: 01)

Initialize the EEPROM of the main PCB ASSY as described in “1.3.1 Initialize EEPROM parameters (function code: 01, 91)” in Chapter 5.

1.4 Configure for Country/Region and Model (Function Code: 74)

Perform settings for a country/region as described in “1.3.24 Configure for country/region and model (function code: 74)” in Chapter 5.

1.5 Activating Memory Writing

Note:

- Setting serial number and entering adjusted value of the laser unit are not operable before activating the memory writing.
- Even the memory writing has been activated by following the procedure, you cannot confirm it on the machine. Therefore, if setting serial number and entering adjusted value of the laser unit are inoperable, perform the procedure again.

<Operating Procedure>

- (1) Check that the machine is in the initial state of maintenance mode.
- (2) Connect the computer to the machine with the USB cable.
- (3) Check that the "Brother Maintenance USB Printer" is set as a default printer. If not, set it as a default printer.
- (4) Double-click the "MemoryAccessTool.exe" file. The following window appears.

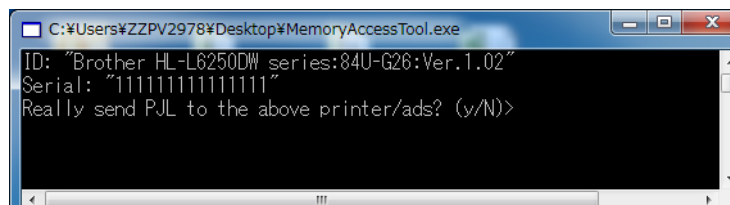

- (5) Enter the [Y]. Memory writing is activated.

1.6 Setting Serial Number and Entering Adjusted Value of Laser Unit

<Operating Procedure>

- (1) Enter the maintenance mode. (Refer to "1.1 How to Enter Maintenance Mode" in Chapter 5.)
- (2) Connect the machine to your computer using the USB cable.
- (3) Double-click the "BrUsbsn.exe" file that was copied to the temporary folder in the computer to start it. "BrUsbSn" screen shown on the right appears.
- (4) Enter the model name of your machine in the [Find a Product] field (ex: DCP-L5500D) and click the [Find a Product] button. [Find a Product] button turns into [Find Next] button, and model name appears in the box above the [Find Next] button.
- (5) Check if the model name of your machine is shown in the box above the [Find Next] button. If you can not find the model name of your machine, keep clicking the [Find Next] button until it appears.
- (6) In the [Port] field on the "BrUsbSn" screen, select the port number assigned to the "Brother Maintenance USB Printer".
- (7) Enter the serial number (15 digits) of the machine in the [Serial No] field.
- (8) Check the laser serial number label attached to the location shown in the figure below.

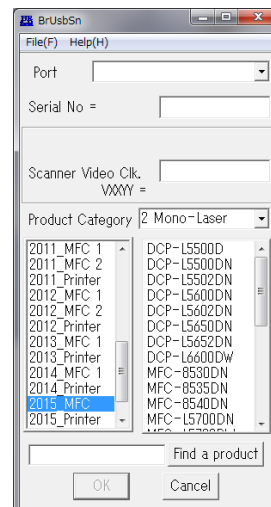

ex.) SQ0812070325520_55356D

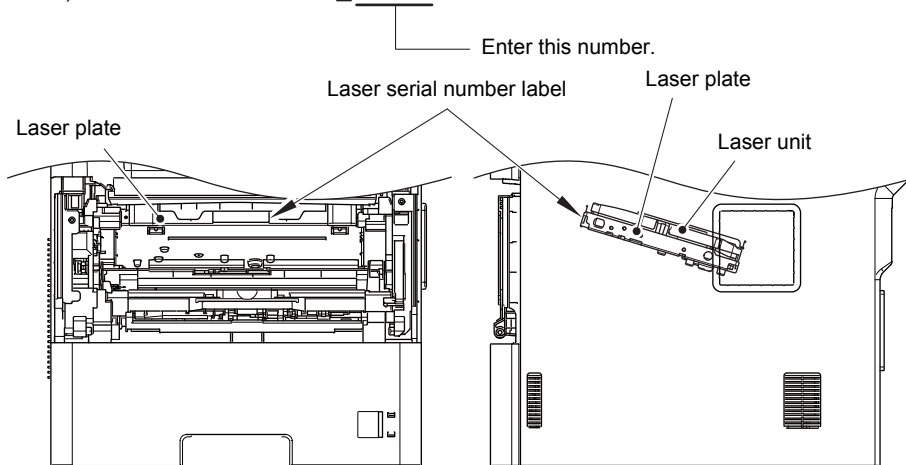

Fig. 4-1

- (9) Enter the numbers (5 digits from sixth last digit to second last digit) on the laser serial number label in the [Scanner Video Clk] field.
- (10) Click the [OK] button. The serial number and the adjusted value of the laser unit are written to the machine.
- (11) The machine quits maintenance mode (function code: 99) and turn OFF the power switch of the machine and disconnect the USB cable from the machine and computer.

Memo:

- You can also refer to "1.3.28 Display machine log information (function code: 80)" in Chapter 5 to set the serial number.
Refer to "APPENDIX 1 SERIAL NUMBERING SYSTEM" for how to check the serial number.

1.7 Acquiring White Level Data (Function Code: 55)

Acquire white level data as described in “1.3.18 Acquire white level data and set CIS scan area (function code: 55)” in Chapter 5.

1.8 Adjusting Left-end and Upper-end Print Position (Function Code: 45) (TT only)

Follow the instruction in “1.3.13 Change USB No. return value / Adjust left-end print position / Adjust upper-end print position / Set HEXDUMP Mode (function code: 45)” in Chapter 5 to adjust left-end or upper-end print position.

1.9 Resetting to Factory Shipping State

<Operating Procedure>

- (1) Check that the machine is in the initial state of maintenance mode.
- (2) Connect the computer to the machine with the USB cable.
- (3) Check that the "Brother Maintenance USB Printer" is set as a default printer. If not, set it as a default printer.
- (4) Double-click the ShippingTool.exe file. The machine is reset to a factory shipping state.
- (5) Unplug the AC cord of the machine.

Memo:

- Be sure to perform the procedure. Otherwise security level (e.g., against information leakage risk) would be low.

2. IF YOU REPLACE THE LOW-VOLTAGE POWER SUPPLY PCB ASSY

■ What to do after replacement

- [Resetting Irregular Power Supply Counter of the Low-voltage Power Supply PCB \(Function Code: 88\)](#)

■ What you need to prepare

None

2.1 Resetting Irregular Power Supply Counter of the Low-voltage Power Supply PCB (Function Code: 88)

Refer to [“1.3.31 Reset counters for consumable parts \(function code: 88\)”](#) in Chapter 5 to reset the irregular power supply counter of the low-voltage power supply PCB.

3. IF YOU REPLACE THE LASER UNIT

■ What to do after replacement

- Entering Adjusted Value of Laser Unit
- Resetting Printed Pages Counter of the Laser Unit

■ What you need to prepare

- (1) One USB cable
- (2) Create a temporary folder on the C drive of the computer (Windows® XP or later).
- (3) Service setting tool (BrUsbsn.zip)
Copy this file into the temporary folder created on the C drive. Extract the copied file.
- (4) Maintenance driver (MaintenanceDriver.zip)
When the maintenance driver is not installed on the computer, copy this file into the temporary folder created on the C drive, and extract the copied file. Refer to **“APPENDIX 3 INSTALLING THE MAINTENANCE PRINTER DRIVER”** for the installation procedure.

3.1 Entering Adjusted Value of Laser Unit

<Operating Procedure>

- (1) Enter the maintenance mode. (Refer to "1.1 How to Enter Maintenance Mode" in Chapter 5.)
- (2) Connect the machine to your computer using the USB cable.
- (3) Double-click the "BrUsbsn.exe" file that was copied to the temporary folder in the computer to start it. "BrUsbSn" screen shown on the right appears.
- (4) Enter the model name of your machine in the [Find a Product] field (ex: DCP-L5500D) and click the [Find a Product] button. [Find a Product] button turns into [Find Next] button, and model name appears in the box above the [Find Next] button.
- (5) Check if the model name of your machine is shown in the box above the [Find Next] button. If you can not find the model name of your machine, keep clicking the [Find Next] button until it appears.
- (6) In the [Port] field on the "BrUsbSn" screen, select the port number assigned to the "Brother Maintenance USB Printer".
- (7) Check the laser serial number label attached to the location shown in the figure below.

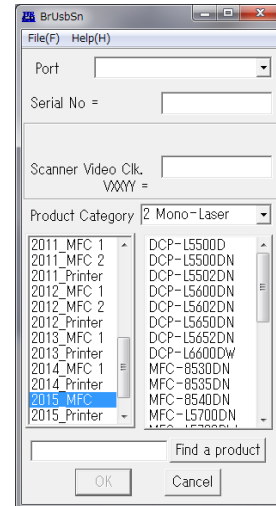

ex.) SQ0812070325520_55356D

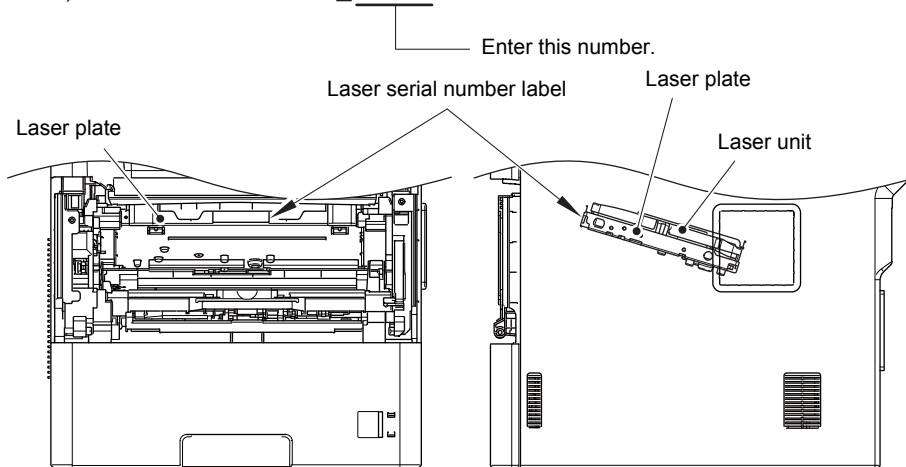

Fig. 4-2

- (8) Enter the numbers (5 digits from sixth last digit to second last digit) on the laser serial number label in the [Scanner Video Clk] field.
- (9) Click the [OK] button. The adjusted value of the laser unit is written to the machine.
- (10) The machine quits maintenance mode (function code: 99) and turn OFF the power switch of the machine and disconnect the USB cable from the machine and computer.

3.2 Resetting Printed Pages Counter of the Laser Unit

Refer to "1.3.31 Reset counters for consumable parts (function code: 88)" in Chapter 5 to reset the printed pages counter of the laser unit.

4. IF YOU REPLACE THE LCD PANEL ASSY OR PANEL PCB

■ What to do after replacement

- Adjusting Touch Panel (Function Code: 61)
- Checking LCD Operation (Function Code: 12)

■ What you need to prepare

Touch pen

4.1 Adjusting Touch Panel (Function Code: 61)

Adjust the touch panel as described in “1.3.19 Adjust touch panel (function code: 61)” in Chapter 5.

4.2 Checking LCD Operation (Function Code: 12)

Check LCD operation as described in “1.3.5 Check LCD operation (function code: 12)” in Chapter 5.

5. IF YOU REPLACE THE ADF UNIT, FIRST SIDE CIS UNIT, SECOND SIDE CIS UNIT OR DOCUMENT SCANNER UNIT

- **What to do after replacement**
 - Acquiring White Level Data (Function Code: 55)
 - Scanning and Printing Check

- **What you need to prepare**
None

5.1 Acquiring White Level Data (Function Code: 55)

Acquire white level data as described in “1.3.18 Acquire white level data and set CIS scan area (function code: 55)” in Chapter 5.

5.2 Scanning and Printing Check

Scan the proper document on the scanner glass, and check if there is any problem on the printed image.

Check if there is any problem on the document scanner unit and the performance of recording part.

6. IF YOU REPLACE THE FUSER UNIT

- **What to do after replacement**
 - **Resetting Printed Pages Counter of the Fuser Unit**

- **What you need to prepare**
 - None

6.1 Resetting Printed Pages Counter of the Fuser Unit

Refer to “1.3.31 **Reset counters for consumable parts (function code: 88)**” in Chapter 5 to reset the printed pages counter of the fuser unit.

7. IF YOU REPLACE A PF KIT

- **What to do after replacement**
 - **Resetting Printed Pages Counter of a PF Kit**

- **What you need to prepare**
 - None

7.1 Resetting Printed Pages Counter of a PF Kit

Refer to “1.3.31 **Reset counters for consumable parts (function code: 88)**” in Chapter 5 to reset the printed pages counter of the appropriate PF kit.

8. IF YOU REPLACE THE TT / LT

■ What to do after replacement

- Installing Firmware (Main Firmware)
- Adjusting Left-end and Upper-end Print Position (TT only)

■ What you need to prepare

- (1) One USB cable
- (2) Create a temporary folder on the C drive of the computer (Windows® XP or later).
- (3) Download utility (FILEDG32.EXE)
Copy this file into the temporary folder created on the C drive.
- (4) Maintenance driver (MaintenanceDriver.zip)
When the maintenance driver is not installed on the computer, copy this file into the temporary folder created on the C drive, and extract the copied file. Refer to **“APPENDIX 3 INSTALLING THE MAINTENANCE PRINTER DRIVER”** for the installation procedure.
- (5) Firmware

Main firmware	djf file (ex. D001G9_A.djf)
---------------	--------------------------------

8.1 Installing Firmware (Main Firmware)

8.1.1 Checking firmware version

Check whether the firmwares installed on the TT and LT are the latest version. If they are the latest version, there is no need to install the firmware. If they are not, be sure to install the firmware to the machine as described in "8.1.2 Installing firmware".

<How to check firmware version>

- (1) Press the [2], and then the [5] key in the initial state of maintenance mode. "MAIN:Ver*.** (#)" is displayed on the LCD.
- (2) Pressing the [▲] or [Mono Start] key changes the display to the next item.
- (3) When you press the [X] key, this operation is finished and the machine returns to the initial state of maintenance mode.

Memo:

- You can also check the sub firmware and main firmware versions by implementing "Print maintenance information (function code: 77)" (refer to "1.3.25 Print maintenance information (function code: 77)" in Chapter 5).

8.1.2 Installing firmware

Note:

- TT and LT have their own firmware respectively. They are included in the main firmware. When connecting the options to the machine and turning on the power switch, the firmwares of these options will be updated with the main firmware version of the machine.

Memo:

- Do not disconnect the power cord, USB flash memory or USB cable from the machine, TT or computer during installing.
- If the install is failed, turn OFF the machine and turn it back on. The machine enters the firmware install mode automatically. Continue the operation procedure below.
- Firmware installation using USB flash memory is inoperable when the machine is in deep sleep mode. Release the deep sleep mode by opening / closing the front cover before the operation.
- When the firmware installation using USB flash memory is failed and the error message or no character appears on the LCD, refer to ["Firmware installation using PC" in this chapter](#) to install firmware using PC.

<Operating Procedure>

■ Firmware installation using USB flash memory

- (1) Create and save a file for automatic firmware update (file name: "_@\$UPD\$OP0.8080") under the USB flash memory.
- (2) Create the "FIRM" folder under the USB flash memory, and save the program file needed for firmware install (ex: D001G9_A.djf) in the "FIRM" folder.
- (3) Connect the USB flash memory to the USB flash memory port at the side of the machine while the machine is in the ready state. "Program Updating.Do not turn off." appears on the LCD and installation starts automatically. Back light goes off.
- (4) When installing is completed, the machine restarts automatically and "Completed..." appears on the LCD. Remove the USB flash memory. If multiple program files are saved in the USB flash memory, other installations start automatically after the restart. If the installation fails, "Unable to Update:*****" appears on the LCD. ("*****" indicates the error code.) Refer to the remedy and eliminate the error. Then reboot the machine and start from the procedure (1).

Error display	Description	Remedy
Unable to Update:0001	Memory full (Failed to secure the work area for update.)	Delete some data saved in the machine and install again.
Unable to Update:0002	No folder is specified	Save the firmware in the root folder (just below the USB flash memory).
Unable to Update:0003	Specified folder does not have a file	
Unable to Update:0004	File access failure	Change the USB flash memory and install again.
Unable to Update:0005	File data parsing error	Acquire the firmware from the data bank again.
Unable to Update:0006	File name has exceeded the character limit	Shorten the file name to be less than 119 Byte.
Unable to Update:0007	Unsupported DJF file detected	Acquire the firmware from the data bank again.
Unable to Update:0008	Other function is in use	Perform it again after finishing the running function.

■ Firmware installation using PC

- (1) Press and hold the [Home] key for approximately five seconds while the machine is in the ready state.
- (2) Press and hold the blank field at the bottom on the LCD for approximately two seconds, and then release the finger.
- (3) Press the [*], [2], [8], [6], and [4] key on the LCD in this order. The machine enters the maintenance mode.
- (4) Connect the machine to your computer using the USB cable.
- (5) Open the temporary folder and double-click "FILEDG32.EXE" to start it, and select "Brother Maintenance USB Printer".
- (6) Drag and drop the required program file (ex. LZXXXX_\$.djf) in the same folder onto the "Brother Maintenance USB Printer" icon in the Filedrgs screen. The file is loaded to the machine, and installing to the flash ROM starts.
- (7) When installing is completed, the machine restarts and returns to the ready state automatically.
- (8) Turn OFF the power switch of the machine, and disconnect the USB cable.

8.2 Adjusting Left-end and Upper-end Print Position (TT only)

Follow the instruction in [“1.3.13 Change USB No. return value / Adjust left-end print position / Adjust upper-end print position / Set HEXDUMP Mode \(function code: 45\)”](#) in [Chapter 5](#) to adjust left-end or upper-end print position.

CHAPTER 5 SERVICE FUNCTIONS

1. MAINTENANCE MODE

Maintenance mode is exclusively designed for checking, setting and adjusting the machine using the keys on the control panel. Using maintenance mode functions, you can conduct operational checks of sensors or test printing, display the log information or error codes, and change the worker switches (WSW) etc.

1.1 How to Enter Maintenance Mode

1.1.1 Method of entering maintenance mode for service personnel

<Operating Procedure>

- (1) Press and hold the [Home] key for approximately five seconds while the machine is in the ready state. The display shown on the right appears on the LCD.



- (2) Press the blank field at the bottom. The display shown on the right appears on the LCD.

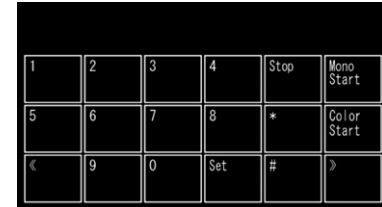

- (3) Press the [*], [2], [8], [6], and [4] keys in this order. The display shown on the right appears on the LCD, and the machine enters into maintenance mode.
- (4) To select any of the maintenance mode functions shown in the “[1.2 List of Maintenance Mode Functions](#)”, use the keypad to enter the maintenance mode function code to be executed.



1.1.2 Method of entering end-user accessible maintenance mode

The maintenance mode functions should only be accessed by service personnel. However, end users are allowed to use some of these functions under the guidance of service personnel over the phone. End users can only use the functions shaded in the table “1.2 List of Maintenance Mode Functions” (function code: 09, 10, 11, 12, 18, 25, 28, 43, 45, 52, 53, 54, 61, 77, 79, 80, 82, 87, 91).

<Operating Procedure>

- (1) Press and hold the [Home] key for approximately five seconds while the machine is in the ready state. The display shown on the right appears on the LCD.

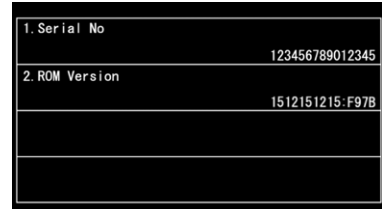

- (2) Press the blank field at the bottom on the LCD. The display shown on the right appears on the LCD.
- (3) Press the [*], [0], and [#] keys on the LCD in this order. The machine enters into ready state to accept function code entry, so press the function code you want to execute.
- (4) Each time the selected maintenance mode function is completed, the machine returns to the ready state automatically.



1.2 List of Maintenance Mode Functions

Function code	Function	Refer to:
01	Initialize EEPROM parameters	1.3.1
08	ADF performance test	1.3.2
09	Print quality test pattern	1.3.3
10	Set worker switches (WSW)	1.3.4
11	Print worker switch (WSW) setting data	1.3.4
12	Check LCD operation	1.3.5
13	Check control panel key operation	1.3.6
18	Save NetConfig data	1.3.7
25	Display software version	1.3.8
28	Change setting for OnePushDemo function	1.3.9
32	Check sensor operation	1.3.10
33	Display LAN connection status	1.3.11
43	Set PC print functions	1.3.12
45	Change USB No. return value / Adjust left-end print position / Adjust upper-end print position / Set HEXDUMP Mode	1.3.13
46	Adjust printable range for each speed level (Full speed / Half speed for thick paper / Quiet Mode)	1.3.14
52	Set country / language	1.3.15
53	Transfer received fax data / log information (fax models only)	1.3.16
54	Fine-tune scanning position	1.3.17
55	Acquire white level data and set CIS scan area	1.3.18
61	Adjust touch panel	1.3.19
67	Continuous print test	1.3.20
69	Print frame pattern (single-side printing)	1.3.21
70	Print frame pattern (duplex printing)	1.3.22
71	Print test pattern	1.3.23
74	Configure for country/region and model	1.3.24
77	Print maintenance information	1.3.25
78	Check main fan operation	1.3.26
79	Delete fax data	1.3.27
80	Display machine log information	1.3.28

Function code	Function	Refer to:
82	Display machine error code	1.3.29
87	Send communication log information to telephone line	1.3.30
88	Reset counters for consumable parts	1.3.31
91	Initialize EEPROM parameters	1.3.1
99	Quit maintenance mode	1.3.32

* The maintenance mode functions shaded in the table can be used by end users.

1.3 Details of Maintenance Mode Functions

1.3.1 Initialize EEPROM parameters (function code: 01, 91)

<Function>

This function is used to initialize the setting values for operation parameters, user switches, and worker switches (WSW) registered in the EEPROM.

Entering function code 01 initializes most EEPROM areas. Entering function code 91 initializes only the specified areas as shown in the table below.

Data item	01	91
Printer switch (Counter information)	Areas not to be initialized	Areas not to be initialized
Error history		
Mac Address (Ethernet Address)		
Password for control panel operation lock	Areas to be initialized	Areas to be initialized
Secure function lock		
Worker switches		
User switches (items initialized when "Factory Reset" is executed)		
Function settings except user switches (settings not subject to "Factory Reset") - Language - Interface		
LAN setting		
PCL core area (Emulation setting values)		

<Operating Procedure>

- (1) Press the [0], and then the [1] key (or press the [9] and then the [1] key as required) in the initial state of maintenance mode. "PARAMETER INIT" is displayed on the LCD.
- (2) When initializing parameters is completed, the machine returns to the initial state of maintenance mode.

Note:

- Function code 01 is for service personnel. Function code 91 is for user support.

1.3.2 ADF performance test (function code: 08)

<Function>

This function is used to test the performance of the automatic document feeder (ADF). The scanned pages of the documents fed by the ADF are counted and the result is displayed on the LCD.

<Operating Procedure>

- (1) Set the documents in the ADF unit.
"DOC. READY" is displayed on the LCD.
- (2) Press the [0], and then the [8] key in the initial state of maintenance mode. "ADF CHECK P.**" is displayed on the LCD, and the documents are ejected while the scanned pages are counted. (** indicates the current count of the scanned pages.)
(For duplex scanning models, as two faces per sheet are scanned, the value increases by two each time a sheet is ejected.)
- (3) When the [X] key is pressed, the machine returns to the initial state of maintenance mode.

Note:

- If no document is set in ADF when the function is executed, "NO DOCUMENT" is displayed on the LCD and the machine returns to the ready state of maintenance mode.

1.3.3 Print quality test pattern (function code: 09)

<Function>

This function is used to print test patterns to check any missing image and print quality.

<Operating Procedure>

- (1) Press the [0], and then the [9] key in the initial state of maintenance mode.
"MAINTENANCE 09" is displayed on the LCD, and the machine starts printing the print quality test pattern (refer to the figure below).
- (2) When printing is completed, the machine returns to the initial state of maintenance mode.

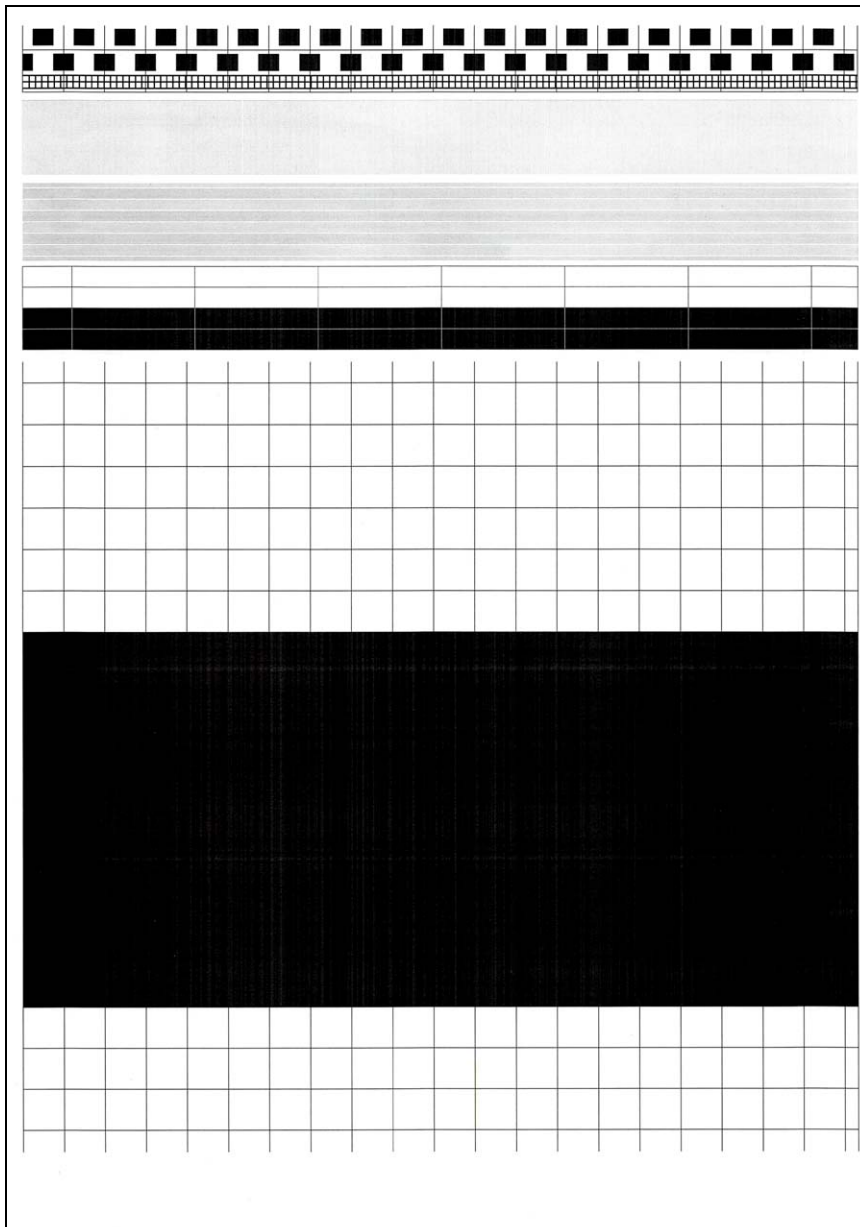

Fig. 5-1

1.3.4 Set worker switches (WSW) and print worker switch setting data (function code: 10, 11)

[1] Set worker switches (function code: 10)

<Function>

The worker switches shown in the table below can be used to set the function to satisfy various requirements. These switch settings can be changed using the keys on the control panel.

The worker switches are factory set to conform to the laws and regulations of the country the machine is shipped to. Do not change these settings unless necessary.

WSW No.	Function	WSW No.	Function
WSW01	Dial pulse setting	WSW43	Function setting 16
WSW02	Tone signal setting	WSW44	Speeding up scanning-1
WSW03	PABX mode setting	WSW45	Speeding up scanning-2
WSW04	Transfer facility setting	WSW46	PC power monitoring and parallel port settings
WSW05	1st dial tone and busy tone detection	WSW47	Switching between high- and full-speed USB
WSW06	[Redial/Pause] key and 2nd dial tone detection	WSW48	USB setup latency
WSW07	Dial tone setting 1	WSW49	End-of-copying beep
WSW08	Dial tone setting 2	WSW50	SDAA setting
WSW09	Protocol definition 1	WSW51	Function setting 17
WSW10	Protocol definition 2	WSW52	Function setting 18
WSW11	Busy tone setting	WSW53	Function setting 19
WSW12	Signal detection condition setting	WSW54	Function setting 20
WSW13	Modem setting	WSW55	Interval for regular developing bias value correction
WSW14	AUTO ANS facility setting	WSW56	Function setting 21
WSW15	Redial facility setting	WSW57	Function setting 22
WSW16	Function setting 1	WSW58	Function setting 23
WSW17	Function setting 2	WSW59	Function setting 24
WSW18	Function setting 3	WSW60	Function setting 25
WSW19	Transmission speed setting	WSW61	Scanning light intensity to judge to be stable 1
WSW20	Overseas communication mode setting	WSW62	Scanning light intensity to judge to be stable 2
WSW21	TAD setting 1	WSW63	Function setting 26
WSW22	ECM and call waiting caller ID	WSW64	Language / default paper size setting
WSW23	Communication setting	WSW65	Paper support setting
WSW24	TAD setting 2	WSW66	Change of the setting is prohibited
WSW25	TAD setting 3	WSW67	Change of the setting is prohibited
WSW26	Function setting 4	WSW68	Change of the setting is prohibited
WSW27	Function setting 5	WSW69	Change of the setting is prohibited
WSW28	Function setting 6	WSW70	Change of the setting is prohibited
WSW29	Function setting 7	WSW71	Change of the setting is prohibited
WSW30	Function setting 8	WSW72	Change of the setting is prohibited
WSW31	Function setting 9	WSW73	Change of the setting is prohibited
WSW32	Function setting 10	WSW74	ADF stop control
WSW33	Function setting 11	WSW75	Switch back ejection distance
WSW34	Function setting 12	WSW76	Set the limit for the number of documents to be ejected in reverse order for single-side scanning from ADF
WSW35	Function setting 13	WSW77	Set the limit for the number of documents to be ejected in reverse order for duplex scanning from ADF
WSW36	Function setting 14	WSW78	Recording stop function when the drum reaches the end of life
WSW37	Function setting 15	WSW79	Function setting 27
WSW38	V.34 transmission settings	WSW80	Copying speed control function
WSW39	V.34 transmission speed	WSW81	Changing emulation function enable/disable setting
WSW40	V.34 modem settings	WSW82	AirPrint Icon No. setting
WSW41	ON-duration of the scanning light source	WSW83	Change of the setting is prohibited
WSW42	Internet mail settings	WSW84	Change of the setting is prohibited

* Refer to the separate manual for details of worker switches.

<Operating Procedure>

- (1) Press the [1], and then the [0] key in the initial state of maintenance mode. "WSW00" is displayed on the LCD.
- (2) Enter the worker switch number that you want to change the setting.
The following display appears on the LCD.

Selector No. 1 Selector No. 8
 ↓ ↓
WSWXX = 0 0 0 0 0 0 0

- (3) Press the [◀] or [▶] key to move the cursor to the desired selector, and change the setting by pressing the [1] or [0] key.
- (4) When changing the setting is completed, press the [SET] key. The new selector setting value is stored in the EEPROM, and the LCD returns to the ready state for worker switch number entry ("WSW00").
- (5) When all switch setting is completed, press the [X] key to return the machine to the initial state of maintenance mode.

Note:

- To cancel operation and return to the initial state of maintenance mode, press the [X] key.
- If there is no entry for one minute or longer on 2-digit worker switch number selection after the first digit was entered, the machine returns to the initial state of maintenance mode automatically.

[2] Print worker switch (WSW) setting data (function code: 11)

<Function>

This function is used to print the worker switch settings and details.

<Operating Procedure>

- (1) Press the [1] key twice in the initial state of maintenance mode. "PRINTING" is displayed on the LCD, and printing the CONFIGURATION LIST (refer to the figure below) starts.
- (2) When printing is completed, the machine returns to the initial state of maintenance mode.

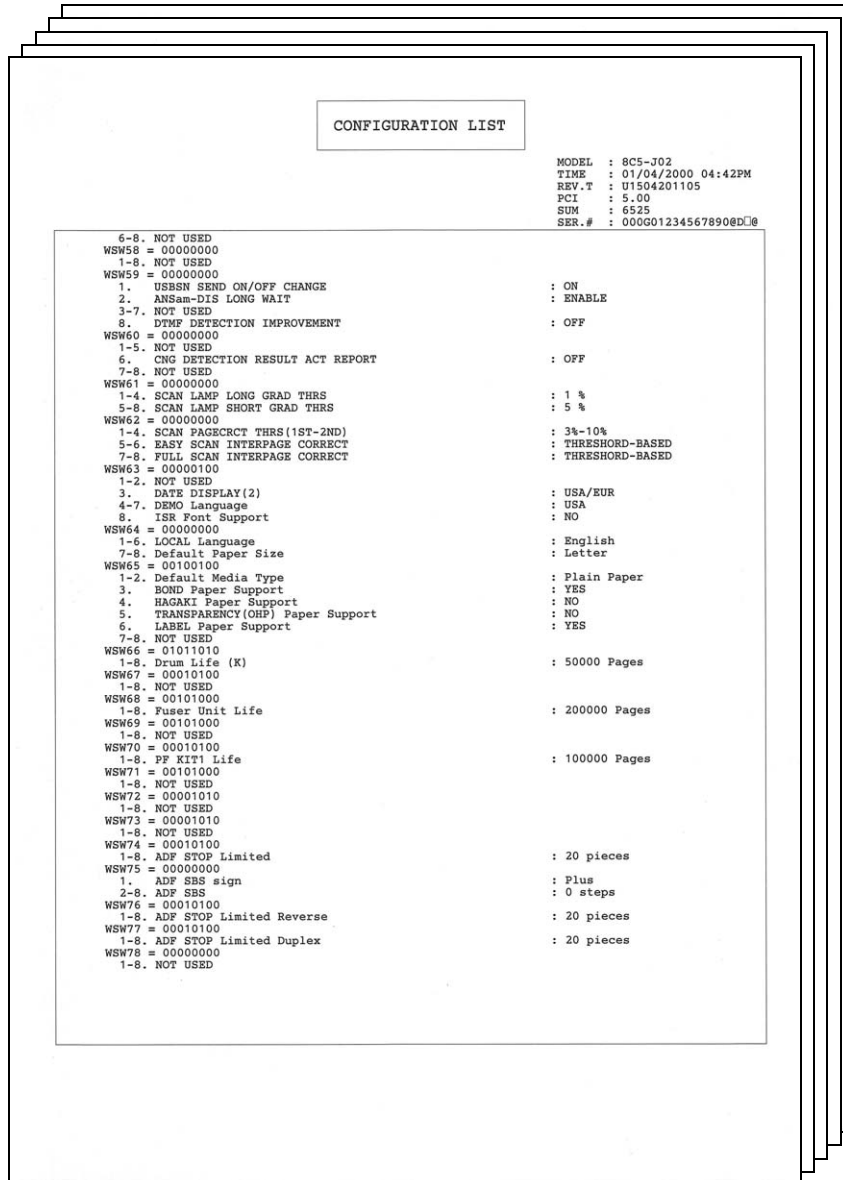

Fig. 5-2

1.3.5 Check LCD operation (function code: 12)

<Function>

This function is used to check that the LCD on the control panel is operating normally.

<Operating Procedure>

- (1) Press the [1], and then the [2] key in the initial state of maintenance mode.
- (2) Each press of the [#] key cycles through the LCD display as shown in the figure below. Also, pressing the [X] key returns the display to the previous state. Pressing the [#] key at the last display returns the display to Display 1.
- (3) When you press the [X] key, the machine returns to the initial state of maintenance mode, regardless of the display status.

■ LCD

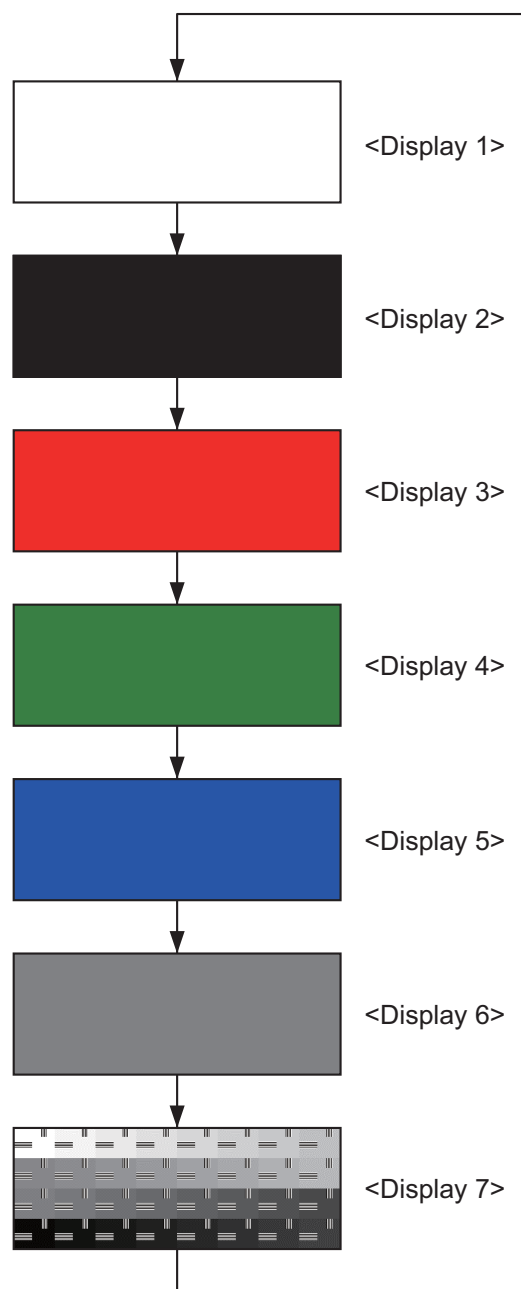

Fig. 5-3

1.3.6 Check control panel key operation (function code: 13)

<Function>

This function is used to check that keys on the control panel are operating normally.

<Operating Procedure>

- (1) Press the [1], and then the [3] key in the initial state of maintenance mode. "00" is displayed on the LCD.
- (2) Press the keys on the control panel according to the numbers provided in the figure below. Each time the key is pressed, the corresponding figure is displayed on the LCD in decimal notation. Check that the number displayed on the LCD matches the number assigned to the key that has been pressed. If the keys are pressed in the incorrect order, "INVALID OPERATE" is displayed on the LCD. Press the [X] key and try again with the correct key.
- (3) When the key operation is normal, the machine returns to the initial state of maintenance mode when the last key is pressed. To cancel operation and return to the initial state of maintenance mode, press the [X] key.

■ Order of pressing keys

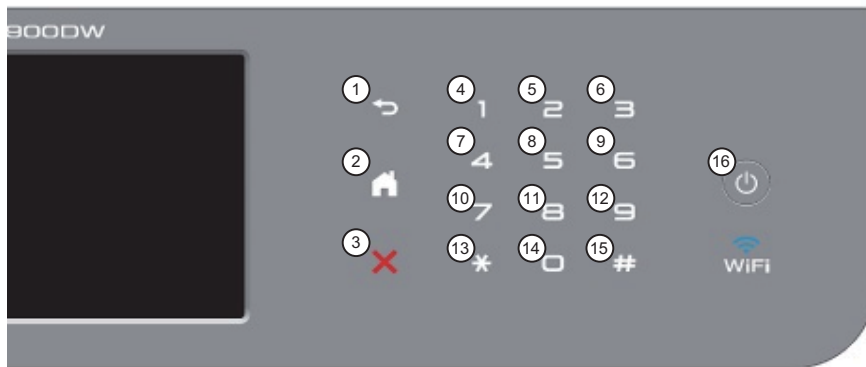

Fig. 5-4

1.3.7 Save NetConfig data (function code: 18)

<Function>

This function is used to save NetConfig data to the USB flash memory.

<Operating Procedure>

- (1) Press the [2], and then the [5] key in the initial state of maintenance mode. "NETCONFIG" is displayed on the LCD.
- (2) Insert the USB flash memory into the USB flash memory terminal.
- (3) Press the [SET] key. "SAVE TO USB" is displayed on the LCD.
- (4) Press the [SET] key. "USB SAVING" is displayed on the LCD, and NetConfig data is saved to the USB flash memory. The machine returns to the initial state of maintenance mode.

1.3.8 Display software version (function code: 25)

<Function>

This function is used to check the version information of the firmwares and programs, or check sum information.

<Operating Procedure>

- (1) Press the [2], and then the [5] key in the initial state of maintenance mode. "TOTAL:Ver*" is displayed on the LCD.
- (2) Pressing the [Mono Start] key changes the display to the next item.
- (3) When you press the [X] key, this operation is finished and the machine returns to the initial state of maintenance mode.

LCD	Description
TOTAL: VerT * ¹	Main firmware version information
SUB1 : Ver1.00 (P) * ¹	Sub firmware version information ((P): Identifier for PCL/PS) * ²
ENG: Ver.1.00	Do not refer to this item because it has nothing to do with DL.
NET : VerA	Network program version information
TT :Ver1.00	TT firmware version information
LT1 :Ver1.00	LT1 firmware version information
LT2 :Ver1.00	LT2 firmware version information
i0801170900:0000	I-FAX version information
B0608071049:5708 * ¹	Boot program creation date
U0612271600:7B0A * ¹	Main firmware creation date
D-----:---- * ⁴	Demo firmware data creation date
F-----:----	Font firmware creation date
P0612271602:BD40 * ¹	Sub firmware (PCL/PS) creation date
ROM Check Sum	Check sum self-diagnosis function * ³

*¹ How to display the check sum information

You can check the check sum information by pressing the [OK] key while each version is displayed. When the [OK] key is pressed again, the LCD returns to the version display.

*² (P) indicates that the firmware supports PCL/PS.

*³ There are two types of check sum information that can be checked with this function. This function checks if the two types of check sum information match each other. When the [SET] key is pressed while "ROM Check Sum" is displayed, check is automatically conducted for each ROM of each software part. When the check sum matches, "OK" is displayed on the LCD. When all ROMs result in OK, "ROM Check Sum OK" is displayed at the end, and the operation is finished. When the check sum of any ROM does not match, "NG" is displayed, and the display stops.

*⁴ This is displayed on the LCD even no firmware is installed.

1.3.9 Change OnePushDemo function setting (function code: 28)

<Function>

This function is used to implement Demo printing by pressing a certain key, and is mainly used for sales promotion at dealers. This function is disabled once printing is performed from the computer. Change the setting to enable the function again.

OnePushDemo = ON(Enabled) / OFF(Disabled).

The setting currently selected is marked "*".

<Operating Procedure>

- (1) Press the [2], and then the [8] key in the initial state of maintenance mode.
"OnePushDemo=ON *" is displayed on the LCD.
- (2) Press the [▲] or [▼] key to display "OnePushDemo=ON" when enabling this function or "OnePushDemo=OFF" when disabling this function.
- (3) Press the [SET] or [Mono Start] key. The setting currently displayed is saved, and the machine returns to the initial state of maintenance mode.

Note:

- To cancel operation and return to the initial state of maintenance mode, press the [X] key.
- Once the OnePushDemo function is enabled, this will not be disabled even when printing is performed from the computer as long as the power switch is not turned OFF. However, if the power switch is turned OFF and then ON again after the OnePushDemo function was enabled, this function will be disabled when printing is performed from the computer.

1.3.10 Check sensor operation (function code: 32)

<Function>

This function is used to check whether the sensors, solenoids, and clutches are operating normally.

<Operating Procedure>

- (1) Press the [3], and then the [2] key in the initial state of maintenance mode. Either of the following examples is displayed on the LCD
 e.g. TNNTSTC2P2**TT**
 e.g. TNNTST---MCTT
 The machine or speaker makes buzzing sound continuously.
 Information related to the LT and TT are not displayed on the LCD when those are not connected.

Note:

- Press the [SET] key to stop the buzzing sound from the speaker.

- (2) Pressing the [Mono Start] key changes the display to the next item.
- (3) Change the conditions subject to sensor detection shown below and check that the display on the LCD changes depending on the sensor status. For example, feed the paper through the registration front/rear sensor, open the front cover or back cover, remove the toner cartridge, or create paper jam at the exit.
- (4) When you press the [X] key, this operation is finished and the machine returns to the initial state of maintenance mode.

<Sensor check>

The table below summarizes the displays on the LCD, sensor names and detection status.

LCD	Sensor name	Detection status	
		With display	No display
TN	Toner amount detection sensor	Beam obstructed	Beam not obstructed
NT	New toner sensor	Sensor not pressed	Sensor pressed
ST	Output tray stack sensor	Ejected paper not yet full	Ejected paper full
C2	T2LT Paper feed sensor	Paper tray 2 closed	Paper tray 2 open
P2	T2LT paper empty sensor	No paper	Paper set
TT	TT connection sensor	TT connected	TT not connected
C1	T1 paper feed sensor	Paper tray 1 closed	Paper tray 1 open
P1	T1 paper empty sensor	No paper	Paper set
MP	MP paper empty sensor	No paper	Paper set
CV	Front cover sensor	Front cover closed	Front cover open
RC	Back cover/duplex tray sensor	Back cover closed	Back cover open
PO	Eject sensor	No paper	Paper set
RM	Registration front sensor	No paper	Paper set
RA	Registration rear sensor	No paper	Paper set
MACxx	Internal temperature sensor	XX°C	NG
OTxx	External temperature sensor	XX°C	NG
OHxx	External humidity sensor	XX%	NG

LCD	Sensor name	Detection status	
		With display	No display
DF	Document detection sensor	No document	Document set
DR	First side document scanning position sensor	No document	Document set
AC	ADF cover sensor	ADF cover closed	ADF cover open
C2	T2LT paper feed sensor (When LT is in use)	Paper tray 2 closed	Paper tray 2 open
P2	T2LT paper empty sensor (When LT is in use)	No paper	Paper set
C3	T3LT paper feed sensor (When LT is in use)	Paper tray 3 closed	Paper tray 3 open
P3	T3LT paper empty sensor (When LT is in use)	No paper	Paper set
E2	T2TT paper feed sensor	TT paper tray 2 closed and No paper	TT paper tray 2 open and Paper set
D2	T2TT paper empty sensor	No paper	Paper set
E3	T3TT paper feed sensor	TT paper tray 3 closed and No paper	TT paper tray 3 open and Paper set
D3	T3TT paper empty sensor	No paper	Paper set
E4	T4TT paper feed sensor	TT paper tray 4 closed and No paper	TT paper tray 4 open and Paper set
D4	T4TT paper empty sensor	No paper	Paper set
E5	T5TT paper feed sensor	TT paper tray 5 closed and No paper	TT paper tray 5 open and Paper set
D5	T5TT paper empty sensor	No paper	Paper set
J2	T2 JAM sensor	No paper	Paper set
J3	T3 JAM sensor	No paper	Paper set
J4	T4 JAM sensor	No paper	Paper set
J5	T5 JAM sensor	No paper	Paper set
AL	TT balance sensor L	With attachment	No attachment
AR	TT balance sensor R	With attachment	No attachment

<Solenoid and clutch check>

Check the corresponding solenoid and clutch by activating the sensor below.

Both solenoid and clutch can not detect error or fault. They only check if they are functioning.

Sensor operation	Solenoid/clutch operation
Change the status of the T1 paper feed sensor from Paper tray 1 open to Paper tray 1 closed.	The T1 pickup clutch remains ON for the specified time.
Change the status of the T2LT paper feed sensor from Paper tray 2 open to Paper tray 2 closed.	The T2LT pickup clutch remains ON for the specified time.
Change the status of the T2LT paper empty sensor from No paper to Paper set.	The T2LT release clutch remains ON for the specified time.
Change the status of the T3LT paper feed sensor from Paper tray 3 open to Paper tray 3 closed.	The T3LT pickup clutch remains ON for the specified time.
Change the status of the T3LT paper empty sensor from No paper to Paper set.	The T3LT release clutch remains ON for the specified time.
Change the status of the MP paper empty sensor from No paper to Paper set.	The MP solenoid remains ON for the specified time.
Change the status of the registration rear sensor from No paper to Paper set.	The registration clutch remains ON for the specified time.
Change the status of the new toner sensor from Not pressed to Pressed.	The develop clutch remains ON for the specified time. Erase Lamp is ON (keep the develop clutch ON until the new toner sensor gets pressed)
Change the status of the T2TT paper feed sensor from TT paper tray 2 open to TT paper tray 2 closed.	The T2TT pickup clutch remains ON for the specified time.
Change the status of the T3TT paper feed sensor from TT paper tray 3 open to TT paper tray 3 closed.	The T3TT pickup clutch remains ON for the specified time.
Change the status of the T4TT paper feed sensor from TT paper tray 4 open to TT paper tray 4 closed.	The T4TT pickup clutch remains ON for the specified time.
Change the status of the T5TT paper feed sensor from TT paper tray 5 open to TT paper tray 5 closed.	The T5TT pickup clutch remains ON for the specified time.
Change the status of the T3TT paper empty sensor from No paper to Paper set.	The T3TT release clutch remains ON for the specified time.
Change the status of the T4TT paper empty sensor from No paper to Paper set.	The T4TT release clutch remains ON for the specified time.
Change the status of the T5TT paper empty sensor from No paper to Paper set.	The T5TT release clutch remains ON for the specified time.

Note:

- LCD display changes by activating the sensors above. However, it does not affect to the operation of the solenoid and clutch. If the sensors to operate the solenoid and clutch are faulty, they are inoperable.

■ Location of sensors

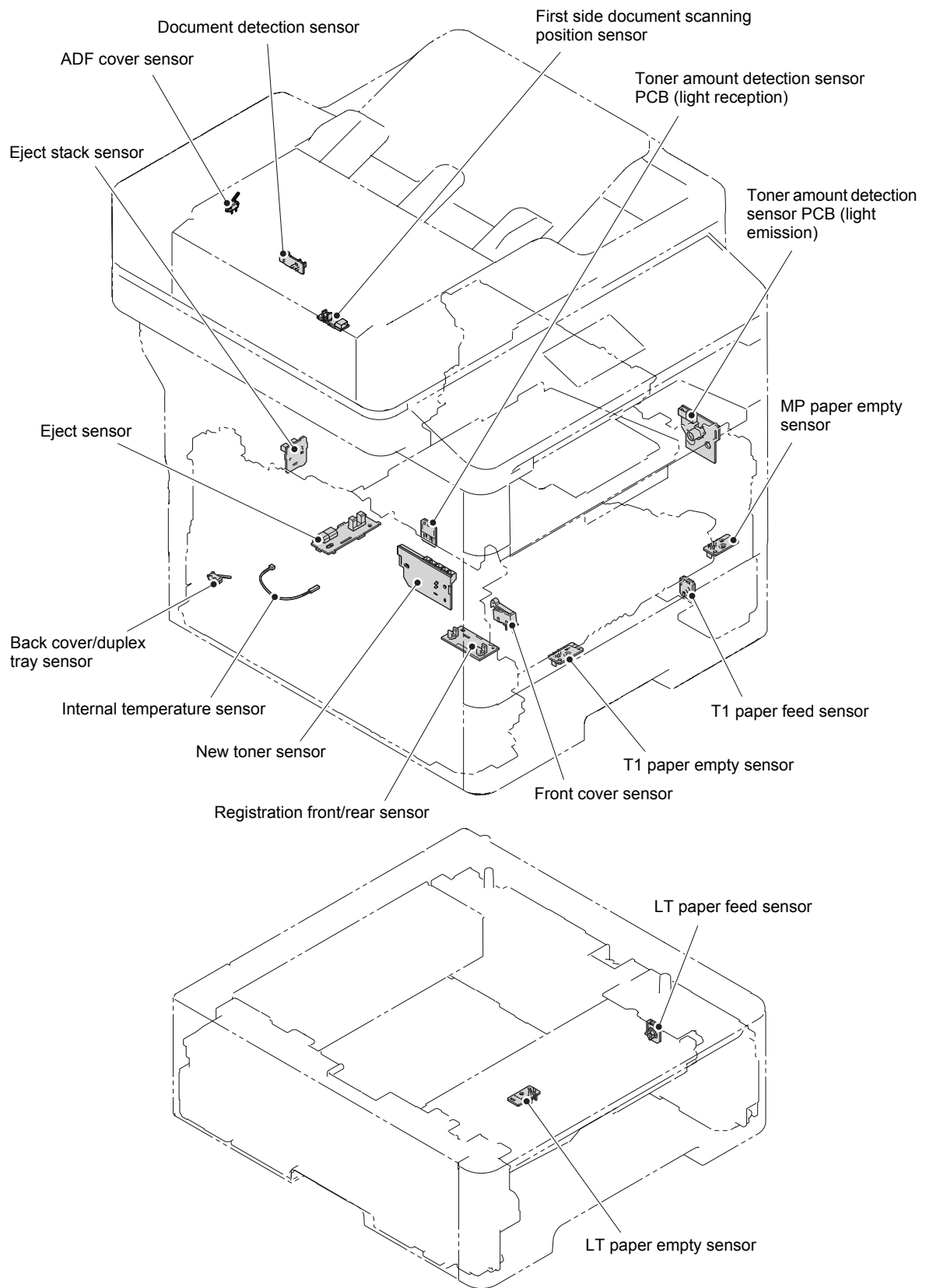

Fig. 5-5

1.3.11 Display LAN connection status (function code: 33)

<Function>

This function is used to check the connection status of the wired LAN.

<Operating Procedure>

- (1) Press the [3] key twice in the initial state of maintenance mode. One of the following items is displayed on the LCD depending on the wired LAN connection of the machine.
- (2) Press the [X] key, and the machine returns to the initial state of maintenance mode.

LCD	LAN connection status
Active 100B-FD	100B-FD
Active 100B-HD	100B-HD
Active 10B-FD	10B-FD
Active 10B-HD	10B-HD
Inactive	Not connected

1.3.12 Set PC print functions (function code: 43)

<Function>

This function is used to change the settings of the various print functions summarized in the table below.

<Operating Procedure>

- (1) Press the [4], and then the [3] key in the initial state of maintenance mode. "Manual Feed" is displayed on the LCD.
- (2) Press the [▲] or [▼] key to display the function you want to change the setting of, and press the [SET] key.
- (3) For fixed parameters (On/Off, etc.), press the [▲] or [▼] key to display the setting you want to apply, and press the [SET] key. For parameters requiring numerical value entry, use the keypad to enter a numerical value directly, and press the [SET] key.
- (4) When the [X] key is pressed, the machine returns to the initial state of maintenance mode.

■ Setting functions

LCD	Description	Set value	Default
Manual Feed	Manual feed setting	On/Off	Off
Resolution	Print resolution	300/600/1,200 dpi	600 dpi
Toner Save	Toner save mode setting	On/Off	Off
Density	Print density level	-6 to 6	0
JB-Can Time	Time until host timeout after a job is canceled	0 to 225 seconds	10 seconds
Sleep Time	Time until sleep mode is entered	0 to 99 minutes	1 minute
Page Protection	Page memory setting	Off/Letter/A4/Legal/Auto	Auto
Emulation	Emulation (print language) setting	Auto/HP/PS	Auto
Auto I/F Time	Interface open time setting	1 to 99 seconds	5 seconds
Media Type	Paper type setting	Thin/Plain/Thick/Thicker/Transparency/Recycled/Bond/Envelopes/EnvThin/EnvThick	Plain or Thin
Paper Size	Image development area setting	Letter/Legal/A4/Executive/ISOB5/JISB5/A5/ISOB6/A6/Monarch/C5/COM10/DL/DLL/A4Long/Postcard/Folio	Letter or A4
Copies	Number of copies	1 to 99 copies	1 copy
Orientation	Print direction setting	Portrait/Landscape	Portrait
P-Pos X-Offset	Print position offset in X (landscape) direction	-500 to 500 (1/300 dpi)	0 (1/300 dpi)
P-Pos Y-Offset	Print position offset in Y (portrait) direction	-500 to 500 (1/300 dpi)	0 (1/300 dpi)
Auto FF	Auto Form Feed setting	On/Off	Off
Auto FF Time	Time until Auto Form Feed timeout	1 to 99 seconds	5 seconds
FF Surpress	Blank page skip setting	On/Off	Off

LCD	Description	Set value	Default
Auto LF	Auto linefeed (LF) setting	On/Off	Off
Auto CR	Auto carriage return (CR) setting	On/Off	Off
Auto WRAP	Auto CRLF by print width	On/Off	Off
Auto Skip	Back end / tip skip setting	On/Off	On
Left Margin	Left margin setting	0 to 145 columns	0 column
Right Margin	Right margin setting	10 to 155 columns	80 columns
Top Margin	Top margin setting	0 to 2.00 inches	0.5 inches
Bottom Margin	Bottom margin setting	0 to 2.00 inches	0.5 inches
Lines	Text lines per page	5 to 128 lines	60 lines
Error Print	Error Print setting in the event of PostScript error	On/Off	On

■ Detail description

LCD	Detail description
Manual Feed	Valid for printing from the computer, and for printing NetWorkConfig, TestPrint, Fontlist, or Configuration from the panel. When the tray is selected on the computer, the setting on the computer supersedes the setting on the LCD.
Resolution	Valid for printing from the computer only. When the resolution is set on the computer, the setting on the computer supersedes the setting on the LCD.
Toner Save	Valid for all types of printing except copy, and the Function Menu setting will also be changed. When the TonerSave is set on the computer, the setting on the computer supersedes the setting on the LCD.
Density	Valid for printing from the computer, and for printing NetWorkConfig, TestPrint, Fontlist, or Configuration from the panel. Linked with the Toner Save setting, and the density is determined based on both settings. When the Density is set on the computer, the setting on the computer supersedes the setting on the LCD.
JB-Can Time	Sets the time until the host timeout after a job is canceled. The setting unit is on the second time scale.
Sleep Time	Sets the time until the sleep mode is entered. The Function Menu setting will also be changed.
Page Protection	Sets the page memory to be secured for data processing before printing in the computer. As this is a setting in the PCL-Core, this does not affect the memory management of the machine.
Emulation	Changes the print language. The Function Menu setting becomes valid. For data with ENTERLANGUAGE, this setting supersedes the setting on the LCD.
Auto I/F Time	Change the interface open time. This setting becomes valid when PC print is instructed, and becomes invalid when PC-Scan or Remote-SetUp is instructed.
Media Type	Valid for printing from the computer only. When the Paper type is set on the computer, the setting on the computer supersedes the setting on the LCD. The default varies depending on the country setting. "Thin" is the default for China and "Plain" is the default for other countries.

LCD	Detail description
Paper Size	Changes the image development area. Sets the drawing size for PC-Print, instead of the setting for Paper Size in the menu. When the Paper size is set on the computer, the setting on the computer supersedes the setting on the LCD. The default varies depending on the country setting. "Letter" is the default for U.S.A. / Canada and "A4" is the default for other countries.
Copies	Valid for printing from the computer only. When the number of copies is set on the computer, the setting on the computer supersedes the setting on the LCD.
Orientation	Changes the printing direction. Valid for printing from the computer only.
P-Pos X-Offset	Sets the print position offset in the X (landscape) direction. Valid for printing from the computer only. When the X-Offset is set on the computer, the setting on the computer supersedes the setting on the LCD.
P-Pos Y-Offset	Sets the print position offset in the Y (portrait) direction. Valid for printing from the computer only. When the Y-Offset is set on the computer, the setting on the computer supersedes the setting on the LCD.
Auto FF	Sets ON or OFF for AutoFF (automatic form feed). Valid for printing from the computer only.
Auto FF Time	Sets the time until timeout after AutoFF is set to ON.
FF Surpress	Sets whether to skip blank pages. Valid for printing from the computer only. On or Off setting of the blank data for copying or faxing cannot be changed in this setting.
Auto LF	Sets the auto linefeed.
Auto CR	Sets the auto carriage return. Adds CR to the LF code.
Auto WRAP	Sets the auto CRLF by the print width.
Auto Skip	Sets whether to skip at the back end / tip of paper. Adds a blank space.
Left Margin	Sets the column space at the left side.
Right Margin	Set the column space at the right side.
Top Margin	Sets the space at the top.
Bottom Margin	Sets the space at the bottom.
Lines	Sets the number of lines in the PCL.
Error Print	Sets the Error Print in the event of a BR-Script 3 error.

1.3.13 Change USB No. return value / Adjust left-end print position / Adjust upper-end print position / Set HEXDUMP Mode (function code: 45)

■ Change USB No. return value

<Function>

When the operating system (OS) installed on the computer is Windows Vista[®], and the machine is connected to this computer using USB2.0FULL, the OS may not be able to obtain the USB device serial number depending on the computer and USB device. If the serial number cannot be obtained, the number of devices increases each time the device is connected to the computer. To avoid this problem, set this function to "USBNo.=ON" and fix the USB No. return value to "0".

LCD	Description
USBNo. = ON	Returns the serial number of the machine.
USBNo. = OFF	Returns "0".

The setting currently selected is marked "*" at the end of the display.

<Operating Procedure>

- (1) Press the [4], and then the [5] key in the initial state of maintenance mode. "USBNo." is displayed on the LCD.
- (2) Press the [Mono Start] or [SET] key. "USBNo.=ON" or "USBNo.=OFF" is displayed on the LCD.
- (3) Press the [▲] or [▼] key to select "USBNo.=ON" or "USBNo.=OFF", and then press the [Mono Start] or [SET] key.
- (4) "Accepted" is displayed on the LCD, and the machine returns to the initial state of maintenance mode.
- (5) Turn OFF the power switch.

Note:

- This setting is applied after the power switch is turned OFF and then ON again.

■ Adjust left-end print position

<Function>

In the event that the left-end print start position deviates, use this function to adjust the position left and right. The adjustable range is -100 to 750 (unit: 300 dpi). (Shifted to the left when the value is negative)

<Operating Procedure>

- (1) Press the [4], and then the [5] key in the initial state of maintenance mode. "USBNo." is displayed on the LCD.
- (2) Press the [▲] or [▼] key to display "X Adjust" on the LCD, and press the [Mono Start] or [SET] key. "XAdjust MP" is displayed on the LCD.
- (3) Refer to <Adjustment option table> below, press the [▲] or [▼] key to select from the adjustment options, and press the [Mono Start] or [SET] key. "XAdj. **= 0**" is displayed on the LCD. (Selected option is shown for **.)
- (4) To shift the writing start position to the left, press the [▼] key to decrease the value. To shift the position to the right, press the [▲] key to increase the value.
- (5) Press the [Mono Start] or [SET] key after adjusting the value. "Accepted" is displayed on the LCD, and the machine returns to the initial state of maintenance mode.
- (6) Press the [X] key to return the machine to the initial state of maintenance mode.

<Adjustment option table>

Adjustment option	LCD	Adjustment option	LCD
MP tray first side	*Adjust MP	MP tray second side	*Adjust DXMP
Paper tray 1 first side	*Adjust T1	Paper tray 1 second side	*Adjust DXT1
Paper tray 2 first side	*Adjust T2	Paper tray 2 second side	*Adjust DXT2
Paper tray 3 first side	*Adjust T3	Paper tray 3 second side	*Adjust DXT3
Paper tray 4 first side	*Adjust T4	Paper tray 4 second side	*Adjust DXT4
Paper tray 5 first side	*Adjust T5	Paper tray 5 second side	*Adjust DXT5
Duplex tray	*Adjust DX		

"X" or "Y" is shown for *.

■ Adjust upper-end print position

<Function>

In the event that the upper-end print start position deviates, use this function to adjust the position up and down. Adjustable range is -50 to 50 (unit: 300 dpi). (Shifted down when the value is negative)

<Operating Procedure>

- (1) Press the [4], and then the [5] key in the initial state of maintenance mode. "USBNo." is displayed on the LCD.
- (2) Press the [▲] or [▼] key to display "Y Adjust" on the LCD, and press the [Mono Start] or [SET] key. "YAdjust MP" is displayed on the LCD.
- (3) Refer to [<Adjustment option table>](#) on the last page, press the [▲] or [▼] key to select from the adjustment options, and press the [Mono Start] or [SET] key. "YAdj. **= 0**" is displayed on the LCD. (Selected option is shown for **.)
- (4) To shift the writing start position down, press the [▼] key to decrease the value. To shift the position up, press the [▲] key to increase the value.
- (5) Press the [Mono Start] or [SET] key after adjusting the value. "Accepted" is displayed on the LCD.
- (6) Press the [X] key to return the machine to the initial state of maintenance mode.

■ Set HEXDUMP Mode

<Function>

This function is used to enter HEXDUMP Mode (hexadecimal mode) or not when the machine starts next time.

Note:

- Do not turn this ON, otherwise the machine enters HEXDUMP mode when it starts. If it is ON and the machine starts in HEXDUMP mode, you can return the machine to the ready state by turning the power OFF then ON again.

1.3.14 Adjust printable range for each speed level (Full speed / Half speed for thick paper / Quiet Mode) (function code: 46)

<Function>

This function is to adjust the printing position in horizontal / vertical direction when it's misaligned on Full speed, Half speed for thick paper, or Quiet Mode.

Position can be adjusted in 11 steps from -0.5% to 0.5% (Negative value → Printing width gets smaller).

<Operating Procedure>

- (1) Press the [4], and then the [6] key in the initial state of maintenance mode. "1.PrtSzAdj Nomal" is displayed on the LCD.
- (2) Press the [▲] or [▼] key to display desired speed on the LCD.
 - Full speed → "1.PrtSzAdj Nomal"
 - Half speed for thick paper → "2.PrtSzAdj THalf"
 - Quiet Mode → "3.PrtSzAdj QHalf"Press the [Mono Start] key. "*.1 *:Main" is displayed on the LCD.
Selected speed is displayed for "*".
- (3) Press the [▲] or [▼] key to display "*.3 *:Print" on the LCD, and press the [Mono Start] key. "PRINTING" is displayed on the LCD, and the print adjustment test pattern (refer to the [next page](#)) is printed on a sheet of paper.
- (4) Adjust the line so that the width is 10mm in horizontal / vertical direction.
Press the [▲] or [▼] key to display desired direction on the LCD.
 - Horizontal direction → "*.1 *:Main"
 - Vertical direction → "*.2 *:Sub"Press the [Mono Start] key. "0.0 %" is displayed on the LCD.
- (5) To make the print width smaller, press the [v] key to decrease the value. Press the [Mono Start] key after adjusting the value.
- (6) Press the [X] key to return the machine to the initial state of maintenance mode after adjusting the value.

■ **Print adjustment test pattern**

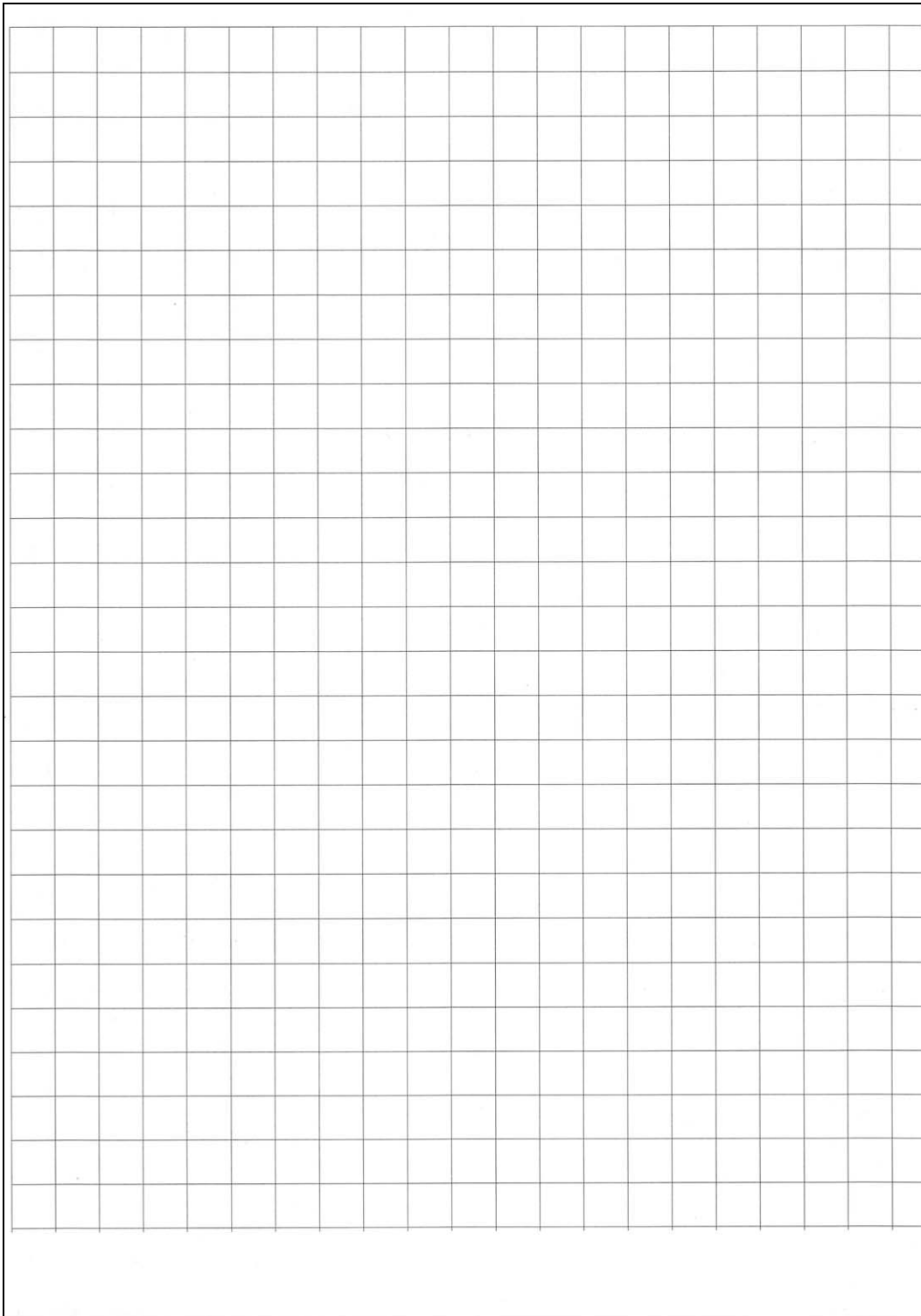

Fig. 5-6

1.3.15 Set country / language (function code: 52)

<Function>

This function is user accessible, and is used to customize the EEPROM according to the language, function settings, and firmware switch settings.

Note:

- This is only valid for models with spec code (detail) described in "[Setting by spec code list](#)".

<Operating Procedure>

- (1) Press the [5], and then the [2] key in the initial state of user maintenance mode. "Set Country" is displayed on the LCD.
- (2) Select the country to be shipped, and then press the [SET] or [OK] key.
- (3) Press the [Yes] key. The new setting is saved. Once the saving is completed, the machine returns to the ready state.

1.3.16 Transfer received fax data / log information (function code: 53) (fax models only)

<Function>

When the machine is unable to print the received fax data due to an error in the printing mechanism, this function is used to transfer the data to another machine. The communication management report, communication list, or machine log information can also be transferred.

Note:

- The number of files that can be transferred in one operation is up to 99. When there are 100 or more files, the operation procedure below must be performed several times to transfer all files.
- When there are both color data files and monochrome data files, monochrome data files are transferred first. When the color function is not supported by the receiver machine, color data files cannot be transferred and an error occurs.

<Operating Procedure>

- (1) Press the [5], and then the [3] key in the initial state of maintenance mode. "FAX TRANSFER" is displayed on the LCD.
 - To check the number of files received, press the [1] key.
"1. NO. OF JOBS" is displayed on the LCD.
Press the [SET] key, and the number of files received is displayed, for example, "NO. OF JOBS: 10".
 - To transfer only the communication management report, press the [2] key.
"2. ACTIVITY" is displayed on the LCD.
 - To transfer the received data, press the [3] key.
(The communication management report is also transferred.)
"3. DOCUMENTS" is displayed on the LCD. If there are no received files, "NO DOCUMENTS" is displayed.
 - To transfer the communication list (latest communication information), press the [4] key.
"4. COM.LIST (NEW)" is displayed on the LCD.
 - To transfer the communication list (information for the past three errors), press the [5] key.
"5. COM.LIST (ERR3)" is displayed on the LCD.
 - To transfer the maintenance information (list printed by function code 77), press the [6] key.
"6. MNT77LIST" is displayed on the LCD.
- (2) Press the [SET] or [OK] key while either "2.ACTIVITY", "3.DOCUMENTS", "4.COM.LIST (NEW)", "5.COM.LIST (ERR3)", or "6.MNT77LIST" is displayed on the LCD. "ENTER NO. & SET" is displayed on the LCD.
- (3) Enter the telephone number of the receiver machine, and press the [SET] or [OK] key again.
- (4) "ACCEPTED" is displayed for approximately two seconds, and the machine starts dialing to transfer the received data.

Note:

- Be sure to enter the telephone number directly using the numerical keys. One-touch dialing is not allowed in this procedure.
- No station ID will be attached to the data to be transferred. Instead, a cover page and end page as shown on the [next page](#) will be automatically attached.

Cover page example

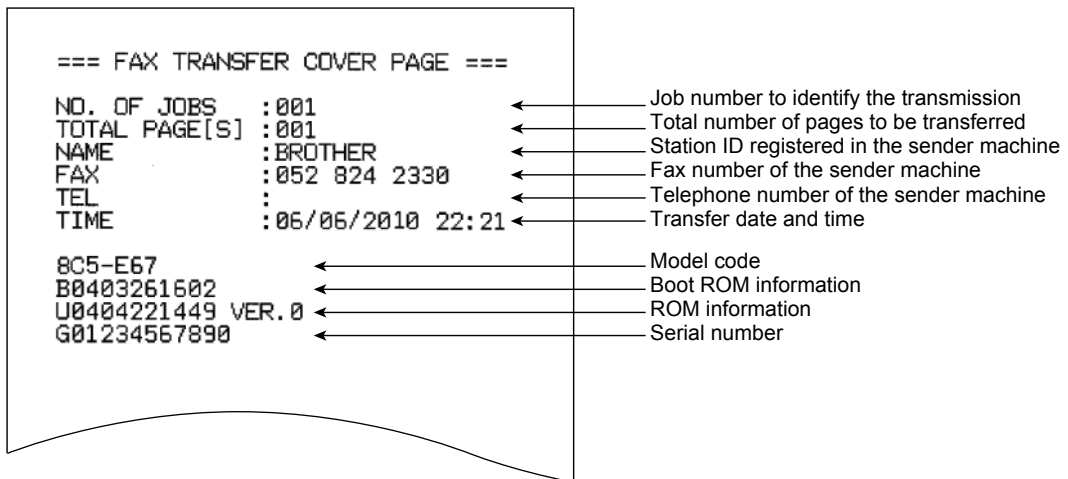

Fig. 5-7

End page example

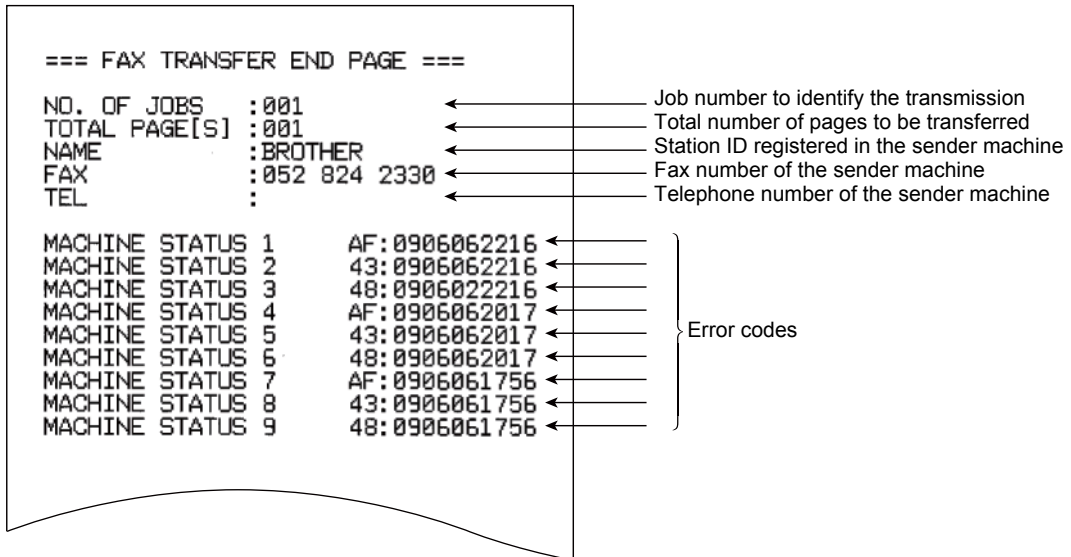

Fig. 5-8

1.3.18 Acquire white level data and set CIS scan area (function code: 55)

<Function>

This function is used to acquire the white level of the CIS unit, and store this data and the scan area in the EEPROM of the main PCB.

<Operating Procedure>

- (1) Press the [5] key twice in the initial state of maintenance mode. "Press START" is displayed on the LCD.
- (2) Press the [Mono Start] key. "SCANNER AREA SET" is displayed on the LCD, and the white level data is obtained.
- (3) After several seconds, the compensation value for the white level data/scanning width is stored in the EEPROM, and the machine returns to the initial state of maintenance mode. If any error is detected during this operation, "SCANNER ERROR" is displayed on the LCD for single-side scanning models, and "SCANNER ERR ADF" or "SCANNER ERR FB" is displayed for duplex scanning models. Pressing the [X] or [Stop] key in this occasion returns the machine to the initial state of maintenance mode.

1.3.19 Adjust touch panel (function code: 61)

<Function>

This function is used to adjust the touch panel.

Note:

- This adjustment requires a touch pen with a thin tip. A commercially available touch pen designed for electronic dictionaries or personal digital assistance (PDA) can be used. If one is not available at hand, order a "Touch pen" from Brother's parts list.

<Operating Procedure>

- (1) Press the [6], and then the [1] key in the initial state of maintenance mode. The adjustment screen shown below appears on the LCD.
- (2) Use a touch pen and touch the center on the mark at the upper left corner of the screen. The mark disappears when touched, then touch the mark at the lower left. Similarly touch the mark at the lower right, upper right and center.

Note:

- Do not use any tools other than a touch pen. In particular, never use a pointed tool (e.g. screwdriver). Using such a tool will damage the touch panel.
- Do not touch the touch panel with your fingers. The contact area of a finger is too large to adjust the touch panel precisely.
- If no operation is performed for one minute or the [X] key is pressed, the machine returns to the initial state of maintenance mode.

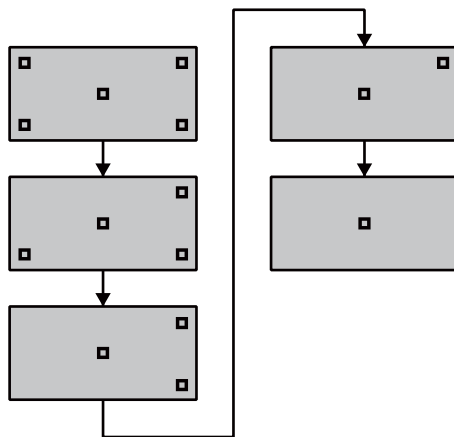

Fig. 5-10

- (3) When the center (the 5th mark) is touched, "OK" is displayed on the LCD if the specified area is adjusted correctly. The machine returns to the initial state of maintenance mode.

Note:

- If "NG" is still displayed on the LCD even after this operation is repeated two to three times, check the connection of the panel flat cable. If the LCD keeps displaying "NG" even there is no problem, replace the LCD panel ASSY.

1.3.20 Continuous print test (function code: 67)

<Function>

This function is used to conduct paper feed and eject tests while printing patterns.

<Operating Procedure>

- (1) Press the [6], and then the [7] key in the initial state of maintenance mode. "SELECT: K 100%" is displayed on the LCD.
- (2) Refer to the [<Print pattern> table](#), press the [▲] or [▼] key to select the print pattern, and press the [SET] key. For total pattern printing, proceed to the procedure (8). Otherwise, "SELECT: A4" is displayed on the LCD.
- (3) Refer to the [<Paper size> table](#), press the [▲] or [▼] key to select the paper size, and press the [SET] key. "SELECT: PLAIN" is displayed on the LCD.
- (4) Refer to the [<Print specification> table](#), press the [▲] or [▼] key to select the media specification, and press the [SET] key. "SELECT: TRAY1 SX" is displayed on the LCD.
- (5) Refer to the [<Print type> table](#), press the [▲] or [▼] key to select the print type, and press the [SET] key. "SELECT: 1PAGE" is displayed on the LCD.
- (6) Refer to the [<Print page> table](#), press the [▲] or [▼] key to select the pages printing, and press the [SET] key. For intermittent pattern printing, "SELECT: 1P/JOB" is displayed on the LCD. For other printings, or move on to the procedure (8).
- (7) Refer to the [<Number of pages per job> table](#), press the [▲] or [▼] key to select the number of pages for 1 job, and press the [SET] key.
(Only for intermittent pattern printing)
- (8) "PAPER FEED TEST" is displayed on the LCD, and printing test pattern starts using the selected conditions.
- (9) When printing is completed, the machine returns to the initial state of maintenance mode.

<Print pattern>

LCD	Description
SELECT:K 100%	Black 100% solid printing
SELECT:W 100%	White 100% solid printing
SELECT:K1%	Black 1% intermittent pattern printing *
SELECT:K5%	Black 5% intermittent pattern printing *
SELECT:Lattice	Lattice printing
SELECT:Total	Print total pattern

* For job printing, up to 500 sheets for single-side printing, and 1,000 sheets for duplex printing.

<Paper size>

LCD	Description
SELECT:A4	A4
SELECT:LETTER	Letter
SELECT:ISOB5	ISO B5
SELECT:JISB5	JIS B5
SELECT:A5	A5
SELECT:A5L	A5L
SELECT:JISB6	JIS B6
SELECT:A6	A6
SELECT:EXECUTE	Executive size
SELECT:LEGAL	Legal size
SELECT:FOLIO	Folio size
SELECT:HAGAKI	Postcard size

<Print specification>

LCD	Description
SELECT:PLAIN	Plain paper
SELECT:THIN	Plain paper (thin)
SELECT:THICK	Plain paper (thick)
SELECT:THICKER	Plain paper (thicker)
SELECT:RECYCLED	Recycled paper
SELECT:BOND	Bond paper
SELECT:LABEL	Label
SELECT:ENVELOPE	Envelope
SELECT:ENVTHIN	Envelope (thin)
SELECT:ENVTHICK	Envelope (thick)
SELECT:HAGAKI	Postcard

<Print type>

LCD	Description
SELECT:TRAY1 SX	Single-side printing from paper tray 1
SELECT:TRAY1 DX	Duplex printing from paper tray 1
SELECT:TRAY2 SX	Single-side printing from paper tray 2
SELECT:TRAY2 DX	Duplex printing from paper tray 2
SELECT:TRAY3 SX	Single-side printing from paper tray 3
SELECT:TRAY3 DX	Duplex printing from paper tray 3
SELECT:TRAY4 SX	Single-side printing from paper tray 4
SELECT:TRAY4 DX	Duplex printing from paper tray 4
SELECT:TRAY5 SX	Single-side printing from paper tray 5
SELECT:TRAY5 DX	Duplex printing from paper tray 5
SELECT:MP SX	Single-side printing from MP tray
SELECT:MP DX	Duplex printing from MP tray
SELECT:AUTO SX	Single-side printing to automatically selected tray
SELECT:AUTO DX	Double-side printing to automatically selected tray

<Print page>

LCD	Description
SELECT:1PAGE	1-page printing
SELECT:CONTINUE	Continuous printing
SELECT:JOB	Intermittent printing per job *

* Selectable only when the printing pattern is set to "K1%" or "K5%", and the print type is not set to the manual feed slot.

<Number of pages per job> (Only for intermittent pattern printing)

LCD	Description
SELECT:1P/JOB	Prints 1 page per job * ¹
SELECT:2P/JOB	Prints 2 pages per job * ¹
SELECT:5P/JOB	Prints 5 pages per job * ¹
SELECT:10P/JOB	Prints 10 pages per job * ¹
SELECT:2I/JOB	Prints 2 images per job * ²
SELECT:5I/JOB	Prints 5 images per job * ² * ³
SELECT:10I/JOB	Prints 10 images per job * ²
SELECT:20I/JOB	Prints 20 images per job * ²

*¹ Selectable only when the SX is set as print type.

*² Selectable only when the DX is set as print type.

*³ Fifth page will be printed as single-side printing.

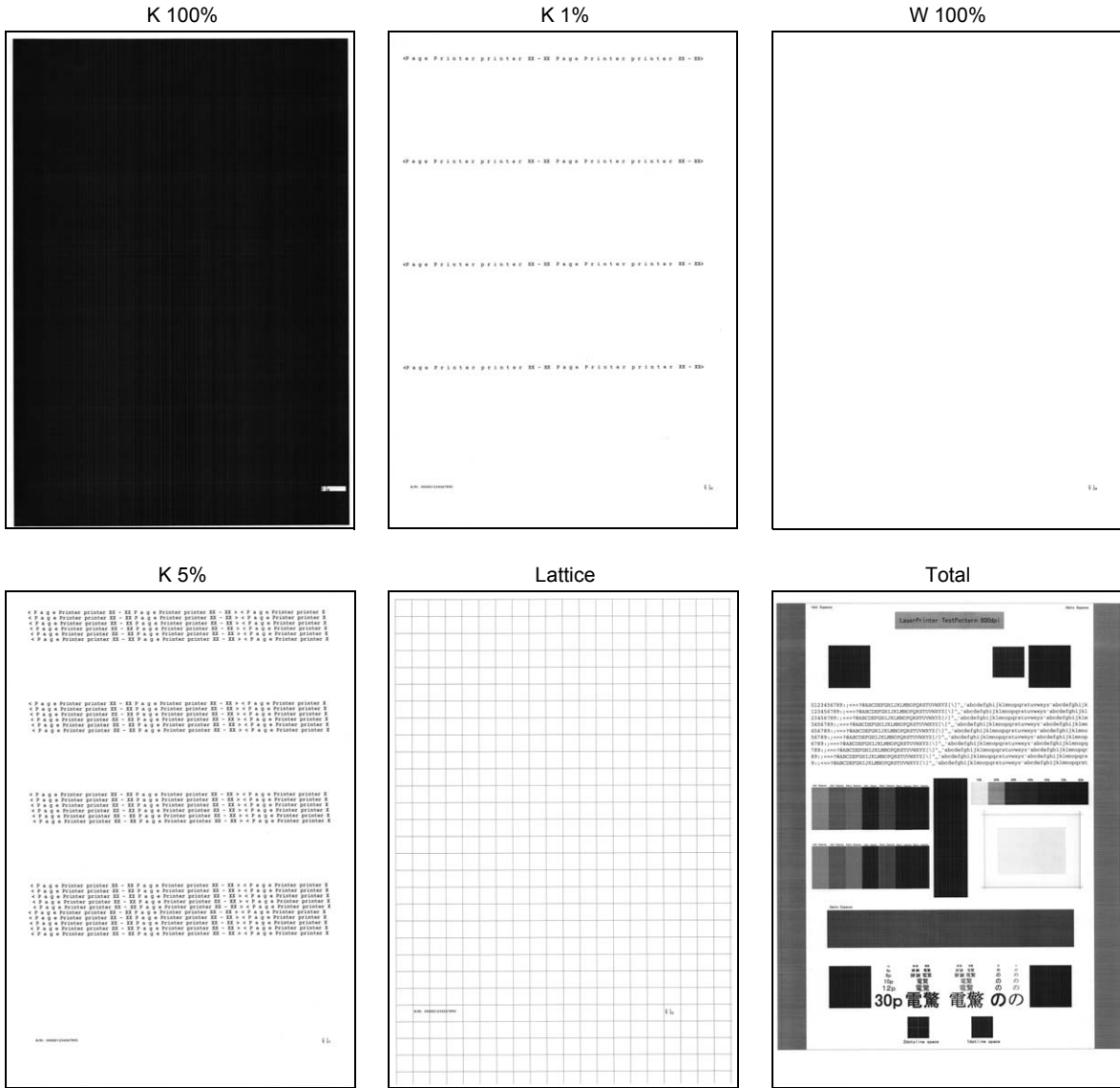

Fig. 5-11

1.3.21 Print frame pattern (single-side printing) (function code: 69)

<Function>

This function is used to print the frame pattern on single side of the paper to check for printing flaws and omission.

<Operating Procedure>

- (1) Set the paper specified in the default paper settings (A4 or Letter) to the paper tray.
- (2) Press the [6], and then the [9] key in the initial state of maintenance mode. "PRINTING" is displayed on the LCD, and the frame pattern (refer to the figure below) is printed on single side of the paper.
- (3) When printing is completed, "WAKU SX" is displayed on the LCD.
- (4) When the [X] key is pressed, the machine stops this operation and returns to the initial state of maintenance mode.

Note:

- If printing fails, printing is stopped with displaying any of the errors shown in the table below. To retry printing, refer to the "Remedy" in the table below and eliminate the error cause. "PRINTING" is displayed on the LCD, and the frame pattern is printed on a single sheet of paper.

Error display	Remedy
Replace Toner	Replace the toner cartridge to release the error.
Cover is Open	Close the front cover.
No Paper	Refill the paper and close the paper tray to release the error.
Jam Tray1	Remove the jammed paper, and then close the paper tray and all covers to release the error.
Jam Rear	

■ Frame pattern

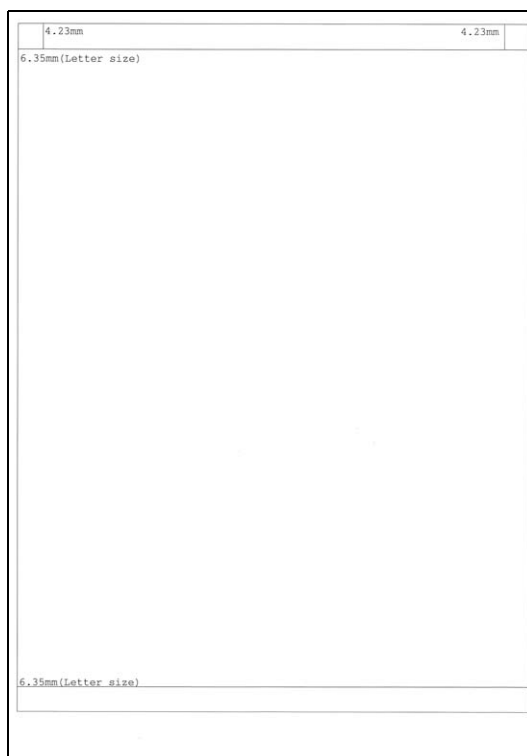

Fig. 5-12

1.3.22 Print frame pattern (duplex printing) (function code: 70)

<Function>

This function is used to print the frame pattern on both sides of the paper to check for printing flaws and omission.

<Operating Procedure>

- (1) Set the paper specified in the default paper settings (A4 or Letter) to the paper tray.
- (2) Press the [7], and then the [0] key in the initial state of maintenance mode. "PRINTING" is displayed on the LCD, and the frame pattern (refer to the figure below) is printed on both sides of the paper.
- (3) When printing is completed, "WAKU DX" is displayed on the LCD.
- (4) When you press the [X] key, this operation is finished and the machine returns to the initial state of maintenance mode.

Note:

- If printing fails, printing is stopped with displaying any of the errors shown in the table below. To retry printing, refer to the "Remedy" in the table below and eliminate the error cause. "PRINTING" is displayed on the LCD, and the frame pattern is printed on both sides of a sheet of paper.

Error display	Remedy
Replace Toner	Replace the toner cartridge to release the error.
Cover is Open	Close the front cover.
No Paper	Refill the paper and close the paper tray to release the error.
Jam Tray1	Remove the jammed paper, and then close the paper tray and all covers to release the error.
Jam Rear	Remove the jammed paper, and then close all covers to release the error.
Jam 2-sided	Remove the jammed paper, and then close the duplex tray and all covers to release the error.
2-sided Disabled	Refill the paper, and then close the paper tray and all covers to release the error.

■ Frame pattern

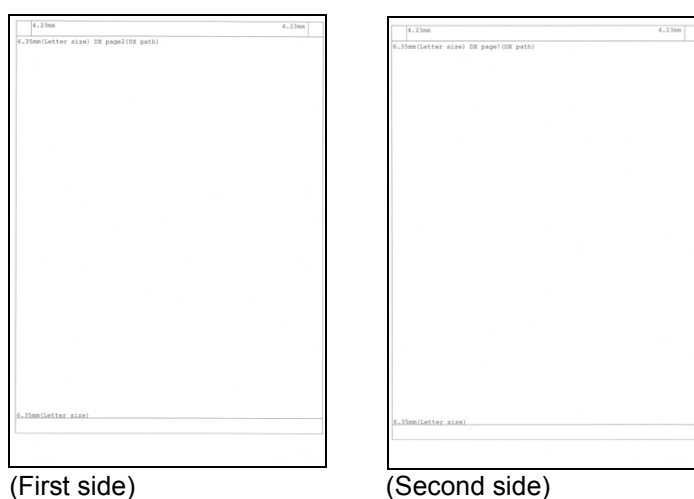

Fig. 5-13

1.3.23 Print test pattern (function code: 71)

<Function>

This function is used to print the test pattern to check whether the develop roller or exposure drum is dirty or damaged.

<Operating Procedure>

- (1) Press the [7], and then the [1] key in the initial state of maintenance mode. "SELECT: LETTER" is displayed on the LCD.
- (2) Refer to the <Paper size> table, press the [▲] or [▼] key to select the paper size, and press the [SET] or [Mono Start] key. "SELECT: PLAIN" is displayed on the LCD.
- (3) Refer to the <Print specification> table, press the [▲] or [▼] key to select the media specification, and press the [SET] or [Mono Start] key. "SELECT: SX" is displayed on the LCD.
- (4) Refer to the <Print type> table, press the [▲] or [▼] key to select the print type, and press the [SET] or [Mono Start] key. "SELECT: 1PAGE" is displayed on the LCD.
- (5) Refer to the <Print page> table, press the [▲] or [▼] key to select the pages printing, and press the [SET] or [Mono Start] key. "PRINTING" is displayed on the LCD, and printing test pattern starts using the selected conditions.
- (6) When printing is completed, "2D3S K" is displayed on the LCD, and it returns to the printing pattern display. Press the [SET] or [Mono Start] key to perform this again.
- (7) Press the [X] key, and the machine returns to the initial state of maintenance mode.

Note:

- If printing fails, printing is stopped with displaying any of the errors shown in the <Error display> table. To retry printing, refer to the "Remedy" in the table and eliminate the error cause. "PRINTING" is displayed on the LCD, and the test pattern is printed.

<Paper size>

LCD	Description
SELECT:A4	A4
SELECT:ISOB5	ISOB5
SELECT:JISB5	JISB5
SELECT:A5	A5
SELECT:A5L	A5L
SELECT:JISB6	JISB6
SELECT:A6	A6
SELECT:EXECUTE	Executive size
SELECT:LEGAL	Legal size
SELECT:FOLIO	Folio size
SELECT:HAGAKI	Postcard size
SELECT:LETTER	Letter

<Print specification>

LCD	Description
SELECT:PLAIN	Plain paper
SELECT:THICK	Plain paper (thick)
SELECT:THIN	Plain paper (thin)
SELECT:THICKER	Plain paper (thicker)
SELECT:RECYCLED	Recycled paper
SELECT:BOND	Bond paper
SELECT:LABEL	Label
SELECT:ENVELOPE	Envelope
SELECT:ENVTHIN	Envelope (thin)
SELECT:ENVTHICK	Envelope (thick)
SELECT:GLOSSY	Glossy paper
SELECT:HAGAKI	Postcard

<Print type>

LCD	Description
SELECT:SX	Single-side printing from paper tray 1
SELECT:DX	Duplex printing from paper tray 1

<Print page>

LCD	Description
SELECT:1PAGE	1-page printing
SELECT:CONTINUE	Continuous printing

<Error display>

LCD	Remedy
Replace Toner	Replace the toner cartridge to release the error.
Cover is Open	Close the front cover.
No Paper	Refill the paper and close the paper tray to release the error.
Jam Tray1	Remove the jammed paper, and then close the paper tray and all covers to release the error.
Jam Rear	Remove the jammed paper, and then close all covers to release the error.

■ Test pattern

2D3S K

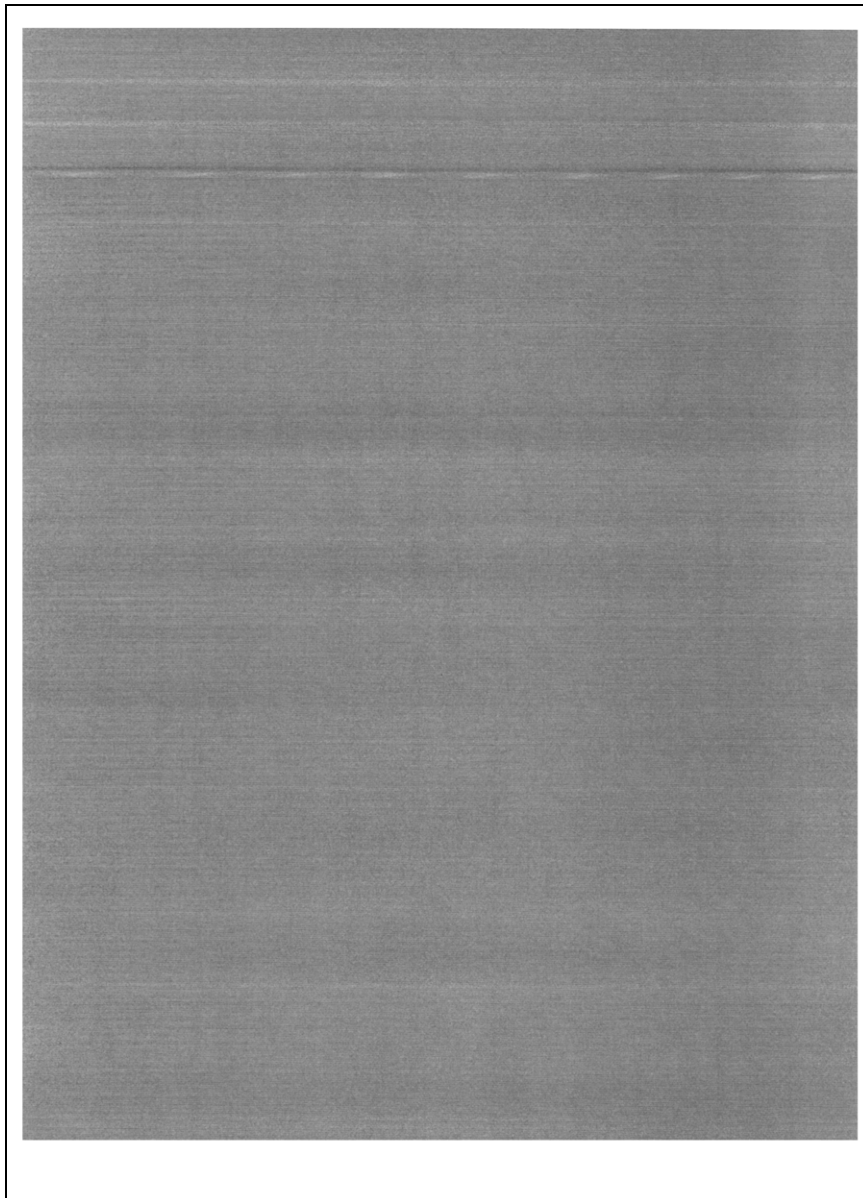

Fig. 5-14

1.3.24 Configure for country/region and model (function code: 74)

<Function>

This function is used to customize the machine according to language, function settings, and worker switch settings.

<Operating Procedure>

- (1) Press the [7], and then the [4] key in the initial state of maintenance mode. The spec code currently set is displayed on the LCD.
- (2) Enter the spec code (four digits) you want to set.
- (3) Press the [Mono Start] key to save the new setting, and "PARAMETER INIT" is displayed on the LCD. The machine then returns to the initial state of maintenance mode.

■ Setting by spec code list

MODEL	Spec Code		Spec Code (Detail)	
DCP-L5500D	Iran	0035	—	—
DCP-L5500DN	CEE-General	1004	—	—
	France/Belgium/ Netherlands	1058	Belgium	1008
			France	7004
			Netherlands	9004
			Others	1004
	Germany	1003	—	—
	Italy/Iberia	1004	—	—
	Pan-Nordic	1004	—	—
	Russia	5004	—	—
	Switzerland	3004	—	—
U.S.A	0001	—	—	
UK	1004	—	—	
DCP-L5502DN	Brazil	0042	—	—
DCP-L5600DN	Argentina	0136	—	—
	India	0145	—	—
	Singapore	0140	—	—
	U.S.A	0101	—	—
DCP-L5602DN	Brazil	0142	—	—
DCP-L5650DN	Argentina	0236	—	—
	Chile	0236	—	—
	U.S.A	0201	—	—
DCP-L5652DN	Brazil	0242	—	—
DCP-L6600DW	Generic	1367	Belgium	1308
			France	7304
			Netherlands	9304
			Italy	B304
			Spain	D304
			Portugal	F304
			Others	1304
	Germany	3304	—	—
	Israel	1317	—	—
	Pan-Nordic	1304	—	—
	Russia	5304	—	—
Switzerland	3304	—	—	
UK	1304	—	—	

Note:

- If there is no entry for one minute or longer, the machine returns to the initial state of maintenance mode automatically, regardless of the display status.
- The spec code list above is current as of March 2016.
- Please contact Brother distributors for the latest information.

MODEL	Spec Code		Spec Code (Detail)	
MFC-8530DN	China	0420	—	—
MFC-8535DN	China	0520	—	—
MFC-8540DN	China	0620	—	—
MFC-L5700DN	CEE-General	0488	Bulgaria	0432
			Croatia	0481
			Czecho	0437
			Hungary	0438
			Poland	0439
			Romania	0433
			Slovakia	0486
			Slovenia	0482
			Others	0450
	France/Belgium/ Netherlands	0458	Belgium	0408
			France	0405
			Netherlands	0409
			Others	0450
	Germany	0403	—	—
	Gulf	0474	Gulf	0441
			South Africa	0424
			Turkey	0425
	Italy/Iberia	0466	Italy	0416
			Portugal	0418
			Spain	0415
	Korea	0444	—	—
	Pan-Nordic	0457	Denmark	0413
			Finland	0412
Norway			0407	
Sweden			0426	
Others			0450	
Russia	0448	—	—	
Singapore	0440	—	—	
Switzerland	0410	—	—	
Taiwan	0423	—	—	
UK	0404	—	—	
MFC-L5700DW	Canada	0402	—	—
	U.S.A	0401	—	—
MFC-L5702DW	Brazil	0442	—	—

Note:

- If there is no entry for one minute or longer, the machine returns to the initial state of maintenance mode automatically, regardless of the display status.
- The spec code list above is current as of March 2016.
- Please contact Brother distributors for the latest information.

MODEL	Spec Code		Spec Code (Detail)	
MFC-L5750DW	CEE-General	0688	Bulgaria	0632
			Croatia	0681
			Czecho	0637
			Hungary	0638
			Poland	0639
			Romania	0633
			Slovakia	0686
			Slovenia	0682
			Others	0650
	France/Belgium/ Netherlands	0658	Belgium	0608
			France	0605
			Netherlands	0609
			Others	0650
	Germany	0603	—	—
	Israel	0617	—	—
	Italy/Iberia	0666	Italy	0616
			Portugal	0618
			Spain	0615
	Pan-Nordic	0657	Denmark	0613
			Finland	0612
Norway			0607	
Sweden			0626	
Russia	0648	—	—	
Switzerland	0610	—	—	
UK	0604	—	—	
MFC-L5755DW	Australia	0606	—	—
	Gulf	0674	Gulf	0641
			South Africa	0624
			Turkey	0625
	Japan	0047	—	—
New Zealand	0627	—	—	
MFC-L5800DW	Argentina	0736	—	—
	Canada	0702	—	—
	U.S.A	0701	—	—
MFC-L5802DW	Brazil	0742	—	—
MFC-L5850DW	U.S.A	0801	—	—
MFC-L5900DW	Canada	0902	—	—
	Chile	0936	—	—
	Gulf	0974	Gulf	0941
			South Africa	0924
			Turkey	0925
	India	0945	—	—
	Philippines	0921	—	—
	Singapore	0940	—	—
U.S.A	0901	—	—	
MFC-L5902DW	Brazil	0942	—	—

Note:

- If there is no entry for one minute or longer, the machine returns to the initial state of maintenance mode automatically, regardless of the display status.
- The spec code list above is current as of March 2016.
- Please contact Brother distributors for the latest information.

MODEL	Spec Code		Spec Code (Detail)	
MFC-L6700DW	Australia	0A06	—	—
	Canada	0A02	—	—
	Chile	0A36	—	—
	Gulf	0A74	Gulf	0A41
			South Africa	0A24
			Turkey	0A25
New Zealand	0A27	—	—	
U.S.A	0A01	—	—	
MFC-L6702DW	Brazil	0A42	—	—
MFC-L6750DW	U.S.A	0B01	—	—
MFC-L6800DW	Generic	0C99	Belgium	0C08
			Bulgaria	0C32
			Croatia	0C81
			Czecho	0C37
			France	0C05
			Hungary	0C38
			Italy	0C16
			Netherlands	0C09
			Poland	0C39
			Portugal	0C18
			Romania	0C33
			Slovakia	0C86
			Slovenia	0C82
			Spain	0C15
	Others	0C50		
	Germany	0C03	—	—
	Israel	0C17	—	—
	Pan-Nordic	0C57	Denmark	0C13
			Finland	0C12
			Norway	0C07
			Sweden	0C26
Others			0C50	
Russia	0C48	—	—	
Switzerland	0C10	—	—	
U.S.A	0C01	—	—	
UK	0C04	—	—	

Note:

- If there is no entry for one minute or longer, the machine returns to the initial state of maintenance mode automatically, regardless of the display status.
- The spec code list above is current as of March 2016.
- Please contact Brother distributors for the latest information.

MODEL	Spec Code		Spec Code (Detail)		
MFC-L6900DW	Argentina	0D36	—	—	
	Australia	0D06	—	—	
	Canada	0D02	—	—	
	Chile	0D36	—	—	
	Generic	0D99	Belgium	0D08	
			Bulgaria	0D32	
			Croatia	0D81	
			Czecho	0D37	
			France	0D05	
			Hungary	0D38	
			Italy	0D16	
			Netherlands	0D09	
			Poland	0D39	
			Portugal	0D18	
			Romania	0D33	
			Slovakia	0D86	
			Slovenia	0D82	
			Spain	0D15	
	Others	0D50			
	Germany	0D03	—	—	
	Gulf	0D74	Gulf	0D41	
			South Africa	0D24	
			Turkey	0D25	
	Israel	0D17	—	—	
	Japan	0147	—	—	
	Korea	0D44	—	—	
	New Zealand	0D27	—	—	
	Pan-Nordic	0D57	Denmark	0D13	
			Finland	0D12	
			Norway	0D07	
Sweden			0D26		
Others			0D50		
Philippines	0D21	—	—		
Russia	0D48	—	—		
Singapore	0D40	—	—		
Switzerland	0D10	—	—		
Taiwan	0D23	—	—		
U.S.A	0D01	—	—		
UK	0D04	—	—		
MFC-L6902DW	Brazil	0D42	—	—	

Note:

- If there is no entry for one minute or longer, the machine returns to the initial state of maintenance mode automatically, regardless of the display status.
- The spec code list above is current as of March 2016.
- Please contact Brother distributors for the latest information.

1.3.25 Print maintenance information (function code: 77)

<Function>

This function is used to print the maintenance information, such as remaining amount of consumables, the number of replacements, and counter information.

<Operating Procedure>

- (1) Press the [7] key twice in the initial state of maintenance mode. Printing maintenance information starts.
- (2) When printing is completed, the machine returns to the initial state of maintenance mode.

■ Maintenance information

```

MAINTENANCE
Print Date:01/01/00

① MFC-L6900DW series②Serial No.=X12345C5N980132 ③Model=8C5-J98④Country=0D01 ⑤ SW CheckSum=97 /NG
⑥ Main ROM: Ver.V U1503092012 ⑦ ROM ChkSum: 62E3 ⑧ NG0C 000000 0303 OKNG00000000000001
⑨ Sub ROM: Ver.0.01 P1501271756 ⑩ RTC Check: OK ⑪ 000000000000000000
⑫ Boot ROM: B1501271738 ⑬ RTC BackUp: NG ⑭ 000000000000000000 00000000
⑮ Engine Version: 0.30 ⑯ Before BackUp: 02:46
⑰ LT1 Main ROM: _ ⑱ After BackUp: 00:00 ⑲ 00000000 00000000 00000000 00000000
⑳ LT2 Main ROM: _ ㉑ 00000000 00000000 00000000 00000000
㉒ TT Main ROM: _ ㉓ USB Prod.ID: 03B0 00000000 00000000 00000000 00000000
㉔ Memory Version: a ㉕ RAM Size = 102Mbyte ㉖ 00000000 00000000 00000000 00000000

Remaining life of :
㉗ *Toner Cartridge: 98% ㉘ Toner Warn Threshold: OFF ㉙ PF Kit 2: 200000 (100%)
㉚ **Drum Unit: 29955 (100%)②PF Kit MP: 50000 (100%) ㉛ PF Kit 3: 200000 (100%)
㉜ Fuser Unit: 199964 (100%)②PF Kit 1: 199972 (100%) ㉜ PF Kit 4: 200000 (100%)
㉝ Laser Unit: 199964 (100%)

<Device Status(Total/2-sided)>
㉞ Total Page Count: 36/0
㉞ Copy Count: 4/0
㉞ PC-Print Count: 32/0
㉞ FAX Count: 0/0
㉞ Other Count: 0/0
㉞ ***Average Coverage(Total): 10.97%
㉞ ***Average Coverage(Current)*: 12.22%
㉞ ***Average Coverage(Previous): 168.97%
㉞ ***Average Coverage(Latest): 0.00%

<Drum Information (Page/Count)>
㉞ Drum Page Count: 45
㉞ Drum Count: 156

<Developing Roller Count(Current/Previous)>
㉞ 1580/111

⑦<Total Pages Printed>
MP Tray: 0 2-sided: 5
Tray 1: 31 Tray 2: 0
Tray 3: 0 Tray 4: 0
Std.Output: 0
Envelope: 0
A4/Letter: 59 A5: 0
Legal/Folio: 0 Others: 0
B5/Executive: 0
Plain/Thin/Recycled: 36
Thick/Thicker/Bond: 0
Envelope/Env.Thick/Env.Thin: 0
Color/Letterhead: 0
Label: 0 Hagaki: 0
㉞ Toner (Current/Previous): 31/5
㉞ Developing Roller Count (Current/Previous)
540/9999999
㉞ Coverage 0% - 1%: 0
㉞ Coverage 1% - 10%: 0
㉞ Coverage 10% - 25%: 0

㉞<Total Paper Jams: 0>
Jam MP Tray: 0 Jam Inside: 0
Jam Tray1: 0 Jam Rear: 0
Jam Tray2: 0 Jam 2-sided: 0
Jam Tray3: 0 Jam Tray4: 0
Jam Tray4: 0

㉞<Error History (last 10 errors)>
Page (C) %
1: E100: 11/24/35 20:15 36 0 0
2: 9309: 11/24/35 20:15 31 0 0
3: 6200: 11/24/35 20:15 30 0 0
4: E100: 11/24/35 20:15 21 0 0
5:
6:
7:
8:
9:
10:

㉞<Replace Count>
Toner Cartridge: 1
Drum Unit: 5 Fuser Unit: 0 Laser Unit: 0
PF Kit MP: 0 PF Kit 1: 0 PF Kit 2: 0
PF Kit 3: 0 PF Kit 4: 0

㉞<Scan Count>
SX Page Count: 0 2-sided Page Count: 0
FB Page Count: 0 Scanner Page Count: 0
ADF Jam: 0
ADF Jam SX: 0 ADF Jam 2-sided: 0

㉞<COM Error>
1: 00000001 01/01/70 00:00
2: 03FF001E 01/01/70 00:00
3: 000003F1 01/01/70 00:00

㉞<Developing Bias: 422V>

㉞<Engine Sensor Log>
KO: 000120/001035 MN: 000490/001060
RS: 000610/001070 EJ: 001210/001115

㉞<Status Log>
831100 831100 831100 830100 831100
831100 830100 830100 831100 830100

<HP ME/HP ME Log>
0/

㉞<Temperature/Humidity>
Temperature: 24 degrees(C) (MAX: 28 MIN: 17)
Humidity: 60% (MAX: 58 MIN: 31)

㉞<Power On Time: 0 hours>
㉞<Power On Count: 57>
㉞<First Date PC-Prn: --/--/-- / RTC: --/--/-->

㉞1:3,160,37,145,53,227,0,0,0
2:0,0,0,0,0,0,0,0,0
3:0,0,0,0,0,0,0,0,0

* Remaining life will vary depending on the types of documents printed,
their coverage and device usage.
** Based on A4/Letter printing.
*** Calculated coverage.

```

Fig. 5-15

1	Model name	33	Remaining life of PF kit 3
2	Serial number	34	Remaining life of PF kit 4
3	Model code	35	Total printed pages
4	Spec code	36	Total copied pages
5	Switch check sum (factory use) and comparison of default / current value	37	Total PC printed pages
6	Main firmware version	38	Total fax pages
7	Sub firmware version	39	Total pages printed by other methods
8	Boot ROM version	40	Accumulated average coverage
9	Engine archive version	41	Average coverage by the current toner cartridge
10	ROM version for T2 control PCB	42	Average coverage by the previous toner cartridge
11	ROM version for T3 control PCB	43	Latest job average coverage
12	TT firmware version	44	Drum page count
13	Memory version	45	Rotations of the drum
14	ROM check sum	46	Total rotations of the developer roller (currently use/previously used toner cartridge)
15	RTC (Real Time Clock) check	47	Total printed pages per paper tray
16	RTC (Real Time Clock) backup	48	Total printed pages per paper type
17	RTC (Real Time Clock) time before backup	49	Printed pages per (currently / previously used) toner cartridge
18	RTC (Real Time Clock) time after backup	50	Total number of rotations of the developer roller per toner cartridge (currently / previously used toner cartridge)
19	USB ID code	51	Pages printed per specified coverage range
20	RAM size	52	Paper jams by sections of the product
21	Function code: 05 result / Wireless LAN setting by country / Wireless LAN output peak / WLAN Setup YES/NO setting / Current toner cartridge type / Previous toner cartridge type / Main PCB inspection log / High voltage inspection log / The number of times that the discharge error, fuser unit error, polygon motor lock error, irregular power supply detection error occurred / Next Power On setting for Power Button	53	Machine error log / Total pages printed at the time of the error / Temperature and humidity
22	Process status	54	Number of times each consumable has been replaced
23	Process status / Process checksum	55	Scanned pages
24	Not necessary for maintenance (ADF sensor log)	56	Communication error log
25	Estimated remaining toner amount	57	Developing bias voltage value
26	Remaining life of drum unit	58	Engine sensor log (Not necessary for maintenance)
27	Remaining life of fuser unit	59	Status log (Not necessary for maintenance)
28	Remaining life of laser unit	60	Current temperature and humidity / Highest and lowest temperature and humidity in the past
29	Toner Low threshold setting	61	Total power distribution time
30	Remaining life of PF kit MP	62	The number of times that the power is turned ON
31	Remaining life of PF kit 1	63	Start date for machine operation
32	Remaining life of PF kit 2	64	New toner cartridge detection log

1.3.26 Check main fan operation (function code: 78)

<Function>

This function is used to check that the main fan is operating normally. Switch the setting among rotation speed 100%, 50%, and OFF.

LCD	Name	Description
F	Main fan	Emits the heat in the fuser unit.

<Operating Procedure>

- (1) Press the [7], and then the [8] key in the initial state of maintenance mode. "F100" is displayed on the LCD and the main fan rotates at 100% speed.
- (2) By pressing the [Mono Start] key, "F50" is displayed on the LCD and the main fan rotates at 50% speed.
- (3) By pressing the [Mono Start] key, "F 0" is displayed on the LCD and the main fan stops.
- (4) When you press the [X] key, this operation is finished and the machine returns to the initial state of maintenance mode.

1.3.27 Delete fax data (function code: 79)

<Function>

This function is used to delete fax data in the machine memory.

<Operating Procedure>

- (1) Press the [7], and then the [9] key in the initial state of maintenance mode. "BACKUP CLEAR" is displayed on the LCD and fax data in the machine memory is deleted.
- (2) Press the [X] key, and the machine returns to the initial state of maintenance mode.

1.3.28 Display machine log information (function code: 80)

<Function>

This function is used to display the log information on the LCD.

<Operating Procedure>

- (1) Press the [8], and then the [0] key in the initial state of maintenance mode.
"MACERR_01:****" is displayed on the LCD (**** indicates error code).
- (2) Pressing the [▲] or [▼] key changes the display item.
- (3) Press the [X] key, and the machine returns to the initial state of maintenance mode.

Maintenance information

LCD	Description
MACERR_##:0000	Machine error log (last ten errors) *1
USB:000G8J000166	Serial number *2
MAC:008077112233	MAC address
PCB:911309123456	Main PCB serial number
KTN_ERM:87%	Estimated remaining toner amount based on the average coverage
KTN_RRM:67%	Estimated remaining toner amount based on the rotations of develop roller
DRUM_PG:00000000	Printed pages for drum unit
PFMP_PG:00000000	Pages fed from PF kit MP
PFK1_PG:00000000	Pages fed from PF kit 1
PFK2_PG:00000000	Pages fed from PF kit 2
PFK3_PG:00000000	Pages fed from PF kit 3
PFK4_PG:00000000	Pages fed from PF kit 4
PFK5_PG:00000000	Pages fed from PF kit 5
FUSR_PG:00000000	Printed pages for fuser unit
LASR_PG:00000000	Printed pages for laser unit
TTL_PG:00000000	Total number of pages printed
DX_PG:00000000	Paper input for duplex tray
TTLCOPY:00000000	Total pages copied
DX_COPY:00000000	Total pages copied on both sides
TTLPCPT:00000000	Total pages printed via PC
DX_PCPT:00000000	Total two-sided pages printed via PC
TTLFAX:00000000	Total List / Fax pages printed *3
DX_FAX:00000000	Total List / Fax pages printed on both sides *3
TTL_OTH:00000000	Total pages printed by other methods
DX_OTH:00000000	Total two-sided pages printed by other methods

LCD	Description
KCVRGUSI:4.32%	Average coverage by the current toner cartridge
KCVRGACC:3.47%	Accumulated average coverage
DRUM:00000000	Rotations of the drum *4
KTN_RND: 00000000	Rotations of the develop roller *4
MP_PG:00000000	Paper input for MP tray
TR1_PG:00000000	Paper input for paper tray
TR2_PG:00000000	Paper input for paper tray 2
TR3_PG:00000000	Paper input for paper tray 3
TR4_PG:00000000	Paper input for paper tray 4
TR5_PG:00000000	Paper input for paper tray 5
STDEJ:00000000	Paper output for machine output tray
DX_PG:00000000	Paper passed through duplex tray
A4+LTR:00000000	Total paper input for A4 and Letter
LG+FOL:00000000	Total paper input for Legal and Folio
B5+EXE:00000000	Total paper input for B5 and Execute
ENVLOP:00000000	Paper input for Envelope
A5 :00000000	Paper input for A5 (including A5 Landscape)
OTHER :00000000	Paper input for other sizes
PLTNRE:00000000	Total printed pages of plain, thin, and recycled paper
TKTRBD:00000000	Total printed pages of thick, thicker, and bond paper
ENVTYP:00000000	Total printed pages of envelope, thick envelope, and thin envelope
LABEL:00000000	Printed labels
HAGAKI:00000000	Printed postcards
COLOR:00000000	Full-color printed pages
LTHD:00000000	Printed pages per letter head
GLOSSY:00000000	Total pages printed on glossy paper
TTL_JAM:00000000	Total paper jams that have occurred
MP_JAM:00000	Paper jams that have occurred in the MP tray
TR1_JAM:00000000	Paper jams that have occurred in paper tray 1
TR2_JAM:00000	Paper jams that have occurred in paper tray 2
TR3_JAM:00000	Paper jams that have occurred in paper tray 3
TR4_JAM:00000	Paper jams that have occurred in paper tray 4
TR5_JAM:00000	Paper jams that have occurred in paper tray 5
IN_JAM:00000000	Paper jams that have occurred in the machine

LCD	Description
RE_JAM:00000000	Paper jams that have occurred at the ejecting section or back cover
DX_JAM:00000000	Paper jams that have occurred in the duplex tray
POWER:00000375	Total power distribution time (unit: hour)
PWRCNT:00000001	The number of times that the power is turned ON
KTN_CH:0000	The number of times that the toner cartridge has been replaced *4
DRUM_CH:0000	The number of times that the drum unit has been replaced *4
FUSR_CH:0000	The number of times that the fuser unit has been replaced *4
LASR_CH:0000	The number of times that the laser unit has been replaced *4
PFMP_CH:000	The number of times that the PF kit MP has been replaced
PFK1_CH:000	The number of times that the PF kit 1 has been replaced
PFK2_CH:000	The number of times that the PF kit 2 has been replaced
PFK3_CH:000	The number of times that the PF kit 3 has been replaced
PFK4_CH:000	The number of times that the PF kit 4 has been replaced
PFK5_CH:000	The number of times that the PF kit 5 has been replaced
KTN_PG1:00000000	Pages printed with the current toner cartridge
KTN_PG2:00000000	Pages printed with the previous toner cartridge
WTNR_PG:00000000	The number of pages printed from the waste toner box
SCN_PG:00000000	The number of scanned pages (except Fax and Copy)
ADSX_PG:00000000	ADF single-side scanned pages (duplex scanning models only)
ADDX_PG:00000000	ADF double-side scanned pages (duplex scanning models only)
ADTL_PG:00000000	Total pages of ADSX_PG and ADDX_PG
FB_PG:000000	Total FB scanned pages
ADSX_JAM:000000	Document jams that have occurred on ADF single-side scanning (duplex scanning models only)
ADDX_JAM:000000	Document jams that have occurred on ADF duplex scanning (duplex scanning models only)
FXTX_PG	The number of faxed pages
COMERR#:00000000	Communication error log (past three errors) *5 (models with fax only)
KDEV_BIAS:400V	Black developing bias voltage value
ENGERR##:000000	Engine error log (last ten errors) *6
HODN_ER:0000	The number of discharge errors occurred
FUSR_ER:0000	The number of fuser unit errors occurred
MTLK_ER:0000	The number of polygon motor lock errors occurred in the laser scanner
DEVSTATUS_###:00	Log for design analysis *7

*1 01 to 10 will be displayed for "##" in chronological order. Pressing the [OK] or [SET] key while the machine error log is displayed shows "PGCNT:00000000 (total pages printed at the time of the error)" on the LCD, and pressing either key again shows "TMP:**.* HUM:***" (TMP: temperature at the time of the error (°C), HUM: humidity at the time of the error (%))" on the LCD. Pressing either key again returns the LCD display to machine error log.

*2 The serial number can be changed according to the procedures below.

- 1) While the serial number is displayed, press the [9], [4], [7], and [5] key in this order to enter the edit mode.
- 2) Use the keypad to enter the first digit of the serial number. Enter the second digit to the 15th digit similarly.

<Entry method of alphanumeric characters>

See the table below and press the corresponding key until the desired character is displayed.

Keypad	Assigned characters
2	2→A→B→C
3	3→D→E→F
4	4→G→H→I
5	5→J→K→L
6	6→M→N→O
7	7→P→Q→R→S
8	8→T→U→V
9	9→W→X→Y→Z

- 3) Press the [SET] or [Mono Start] key. The serial number is saved and the machine returns to the initial state of maintenance mode.

*3 For models without fax, the LCD displays "TLLIST:00000000 (List pages printed)".

*4 Pressing the [SET] key while the replacement count by consumables is displayed shows "DATE_XX:000000 (XX: name of consumables)" and the date of replacement on the LCD. (Models without RTC does not display the replacement date.) Pressing the key again displays the number of times that consumables have been replaced on the LCD.

*5 Pressing the [SET] key while the communication error is displayed shows "DATE:0000000000" and the date of replacement on the LCD. (Models without RTC does not display the replacement date.) Pressing the key again displays communication errors on the LCD.

*6 01 to 10 will be displayed for "##" in chronological order. Pressing the [SET] key while the machine error log is displayed shows "TM:00000 BT:000 (TM: the minutes passed from the previous error, BT: the number of times that the power is turned ON/OFF) on the LCD. Pressing either key again returns the LCD display to machine error log.

*7 01 to 10 will be displayed for "##" in chronological order. Pressing the [SET] key while log for design analysis is displayed shows "PGCNT:00000000 (total pages printed at the time of the error)" on the LCD. Pressing the either key again returns the LCD display to log for design analysis.

1.3.29 Display machine error code (function code: 82)

<Function>

This function is used to display the latest error code on the LCD.

<Operating Procedure>

- (1) Press the [8], and then the [2] key in the initial state of maintenance mode. "MACHINE ERR XXXX" is displayed on the LCD.
- (2) Press the [X] key, and the machine returns to the initial state of maintenance mode.

1.3.30 Send communication log information to telephone line (function code: 87)

<Function>

This function is used to send the error list to service personnel at a remote service station when a fax communication problem has occurred in the user's machine. Receiving the error list allows the service personnel to analyze the problem current in the user's machine.

<Operating Procedure>

- Service side
- (1) Make a call from the service side equipment to the user side equipment.
- User side
- (2) Press and hold the [Home] key while the machine is in the ready state until the LCD display changes.
- (3) Press and hold the blank field at the bottom of the LCD until the LCD display changes.
- (4) Press the [*], [0], [#], [8], and [7] key in this order. "SENDING P.01" is displayed on the LCD and sending error list starts. When the error list is sent, the machine returns to the ready state.
- Service side
- (5) Once the user side equipment started sending the error list, press the [FAX Start] key. "Send or Receive? / 1.Send 2.Receive" is displayed on the LCD.
- (6) Press the [2] key. Receiving the error list starts.

1.3.31 Reset counters for consumable parts (function code: 88)

<Function>

This function is performed to reset the counter for each consumable part in the main PCB after that has been replaced.

<Operating Procedure>

- (1) Press the [8] key twice in the initial state of maintenance mode. "Reset-Laser Unit" is displayed on the LCD.
- (2) Press the [▲] or [▼] key to display the part with the counter to be reset on the LCD, and press the [Mono Start] key.
- (3) "*****OK?" is displayed on the LCD. Press the [Mono Start] key to reset the counter for the selected part and return the display to the procedure (2). (***** represents the name of the selected part)
- (4) Press the [X] key, and the machine returns to the initial state of maintenance mode.

Selectable parts are shown in the table below.

LCD	Part name	Counter to be reset
Reset-Laser Unit	Laser unit	Printed pages counter
Reset-Fuser Unit	Fuser unit	Printed pages counter
Reset-PF Kit T1	PF kit 1	Printed pages counter
Reset-PF Kit T2	PF kit 2	Printed pages counter
Reset-PF Kit T3	PF kit 3	Printed pages counter
Reset-PF Kit T4	PF kit 4	Printed pages counter
Reset-PF Kit T5	PF kit 5	Printed pages counter
Reset-PF Kit MP	PF kit MP	Printed pages counter
Reset-LVPS	Low-voltage power supply PCB ASSY	Irregular power supply detection counter

1.3.32 Quit maintenance mode (function code: 99)

<Function>

This function is used to quit the maintenance mode, restart the machine, and return it to the ready state. Also forcefully close the fuser unit error.

<Operating Procedure>

- (1) Press the [9] key twice in the initial state of maintenance mode. The machine quits the maintenance mode and returns to the ready state.

2. OTHER SERVICE FUNCTIONS

2.1 Print Communication Error List

<Function>

This function is used to print the communication error list (Communication List).

<Operating Procedure>

- (1) Press and hold the [Home] key for approximately five seconds while the machine is in the ready state.
- (2) Press the blank field at the bottom on the LCD. The display shown on the right appears on the LCD.

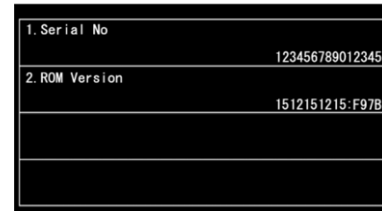

1. Serial No	123456789012345
2. ROM Version	1512151215:F97B

- (3) Press the [#], [1], [0], [4], [1], and [4] keys in this order in approximately 2 seconds.
- (4) Communication error list (Communication List) is printed. When printing is completed, the machine returns to the ready state.



1	2	3	4	Stop	Mono Start
5	6	7	8	*	Color Start
◀	9	0	Set	#	▶

2.2 Reset the Drum Unit Counter

<Function>

This function is performed to reset the drum unit counter.

<Operating Procedure>

- (1) Make sure the machine is turned on.
- (2) Press [Settings] > [ALL Settings] > [Machine Info.] > [Parts Life].
- (3) Press [Drum] until the Touchscreen message changes, and then press [Yes].
- (4) Press the [Home] key.

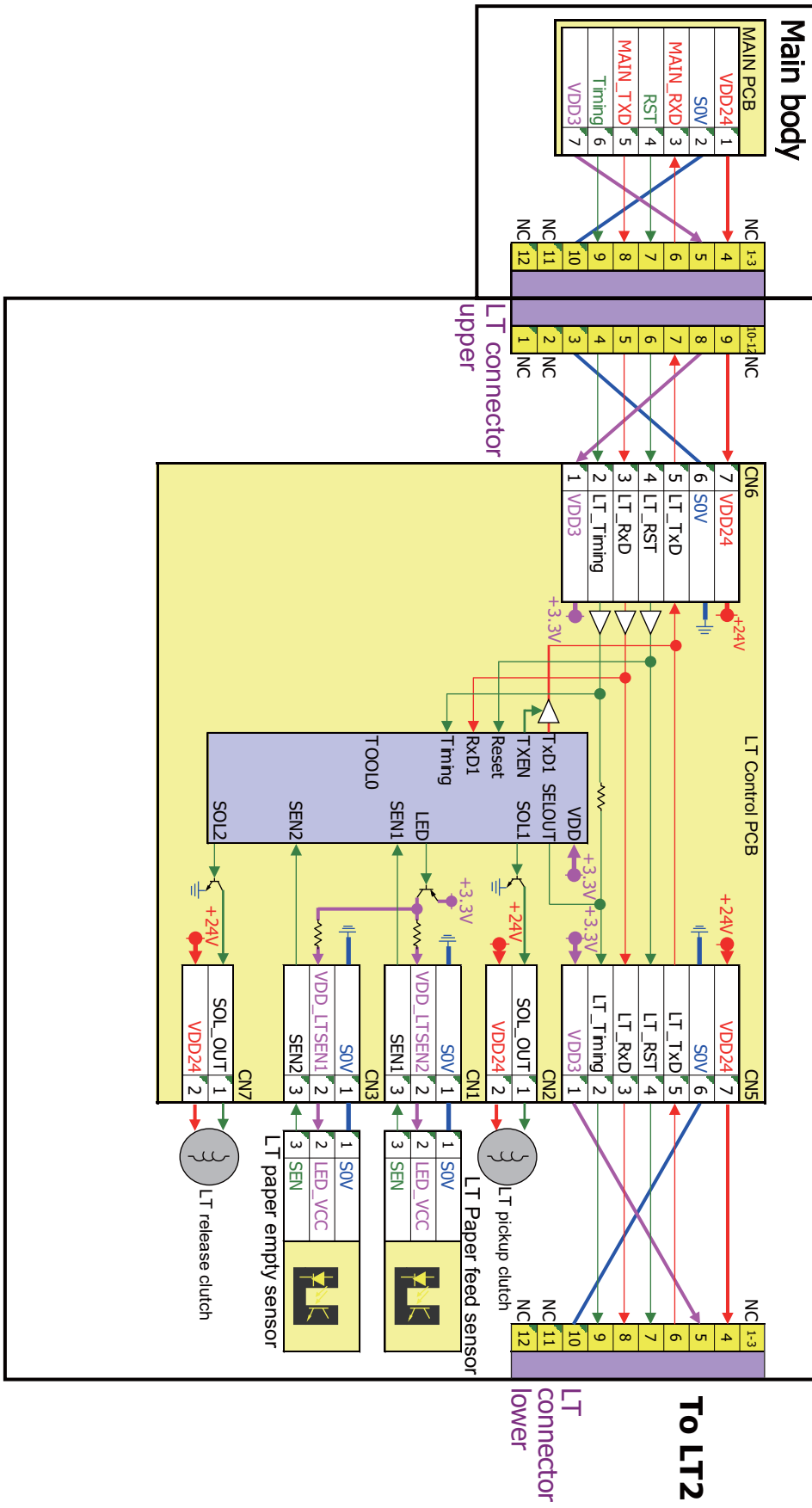

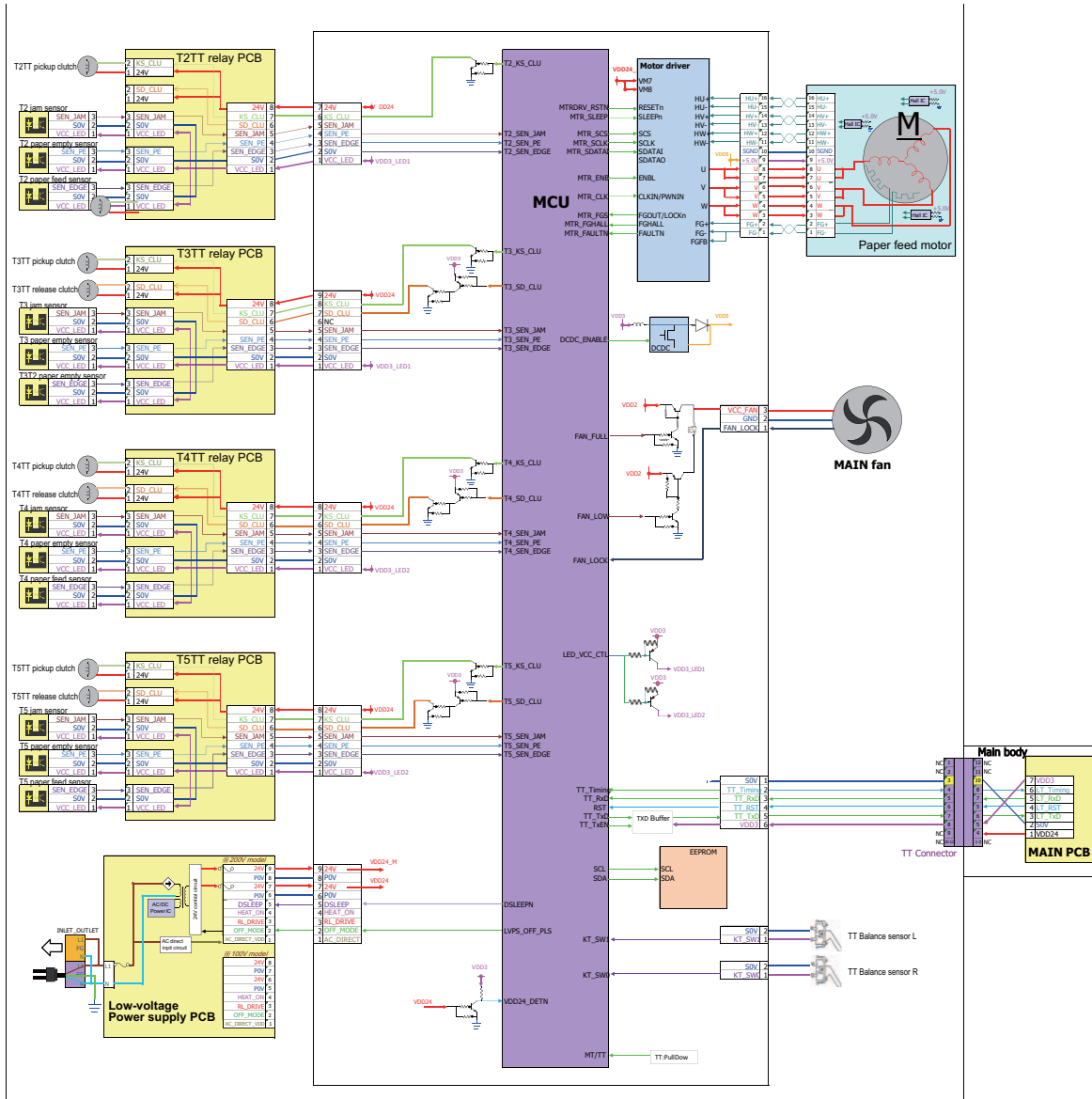

CHAPTER 7 PERIODICAL MAINTENANCE

1. SAFETY PRECAUTIONS

To avoid creating secondary problems by mishandling, follow the warnings and precautions below during maintenance work.

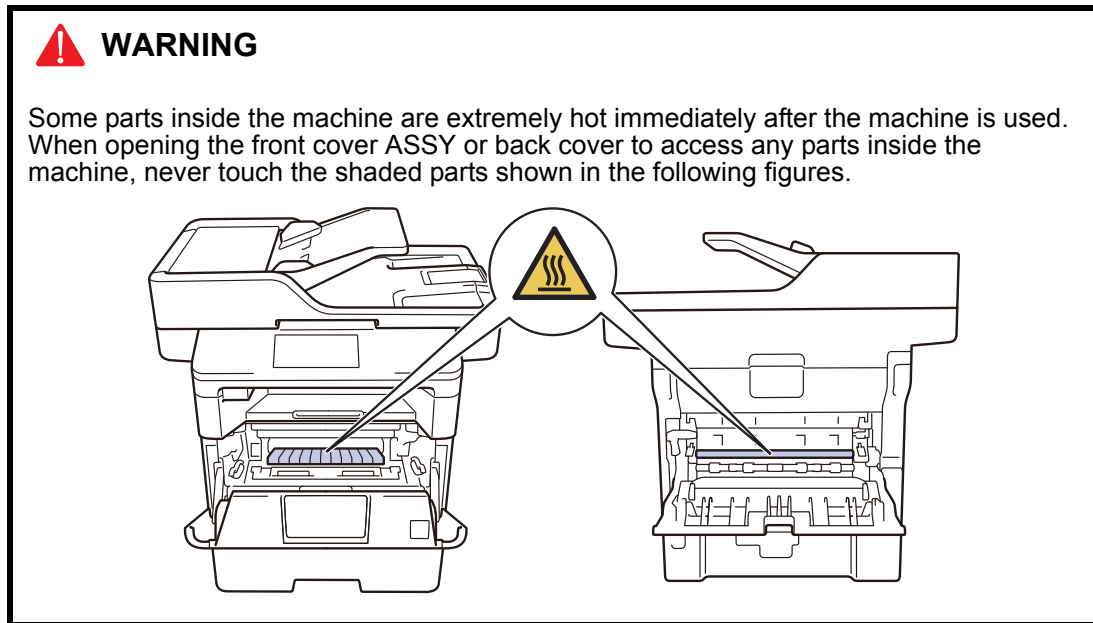

- Be careful not to lose screws, washers, or other parts removed.
- If there are grease application parts, apply grease refer to [Chapter 3](#).
- When using soldering irons or other heat-generating tools, take care not to accidentally damage parts such as wires, PCBs and covers.
- Static electricity charged in your body may damage electronic parts. When transporting PCBs, be sure to wrap them in conductive sheets.
- When replacing the PCB and all the other related parts, put on a grounding wrist band and perform the job on a static mat. Also take care not to touch the conductor sections on the flat cables or on the wire harness.
- After disconnecting flat cables, check that each cable is not damaged at its end or shortcircuited.
- When connecting flat cables, do not insert them at an angle. After insertion, check that the cables are not at an angle.
- When connecting or disconnecting harnesses, hold the connector body, not the cables. If the connector is locked, release it first.
- After a repair, check not only the repaired portion but also harness treatment. Also check that other related portions are functioning properly.
- Forcefully closing the front cover without mounting the toner cartridge and the drum unit can damage the machine.
- The insulation sheet should not be damaged.

2. PERIODICAL REPLACEMENT PARTS

2.1 Preparation

■ Disconnecting Cables and removing Accessories

Prior to proceeding with the disassembly procedure,

- (1) Disconnect the following:
 - AC cord
 - USB cable (if connected)
 - LAN cable (if connected)
 - Line cord (if connected)
- (2) Remove the following:
 - Paper tray
 - Toner cartridge and Drum unit
 - Duplex tray
 - LAN port cap

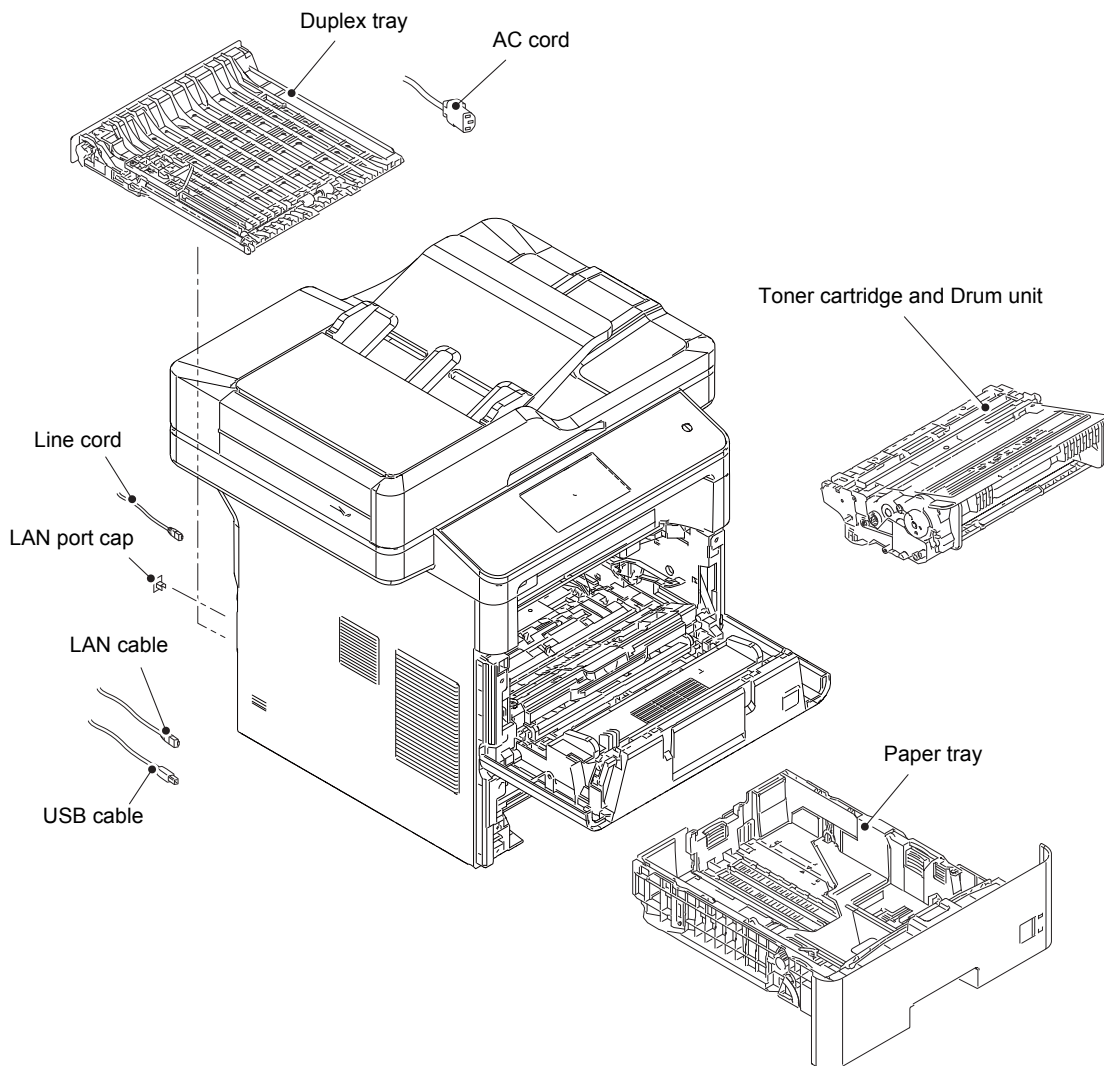

Fig. 7-1

2.2 Fuser unit

- (1) Open the back cover.
- (2) Push both ribs of the back cover in the direction of the arrows, and remove the two bosses on the outer chute.

Note:

- Be careful not to damage the ribs inside the back cover.

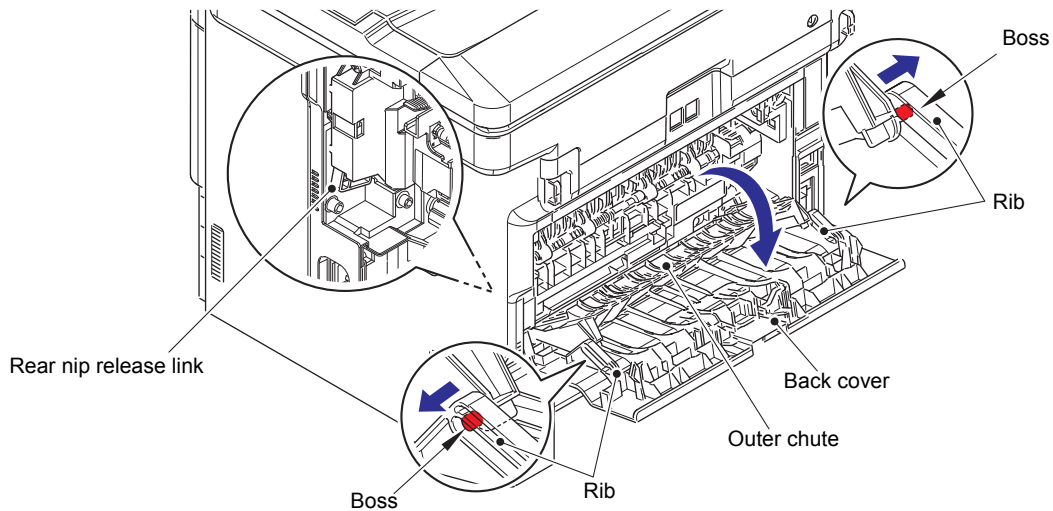

Fig. 7-2

Assembling Note:

- When attaching the back cover, open the front cover and attach the back cover while lifting the rear nip release link.

- (3) Remove the back cover from the boss A, and remove the back cover.
- (4) Open the outer chute approximately 80 degrees. Remove the outer chute from boss B, and remove the outer chute from the machine.

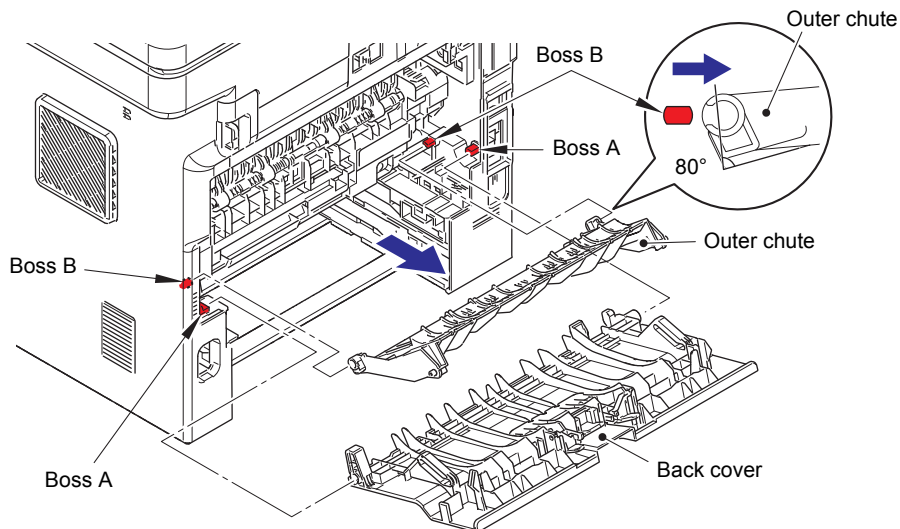

Fig. 7-3

- (5) Push the two knobs on the fuser cover, and pull the fuser cover down in the direction of the arrow.
- (6) Remove the fuser cover from the bosses on the fuser unit, and remove the fuser cover.

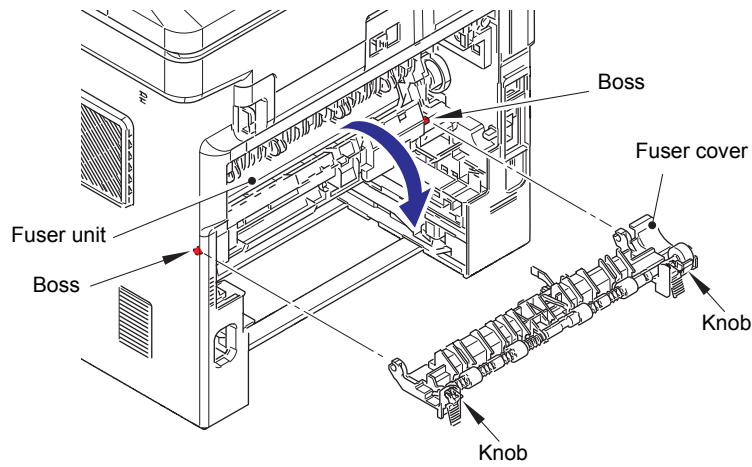

Fig. 7-4

- (7) Remove the taptite bind B M4x12 screw, and remove the fuser unit line cover R.
- (8) Open the front cover, and release the nip of the pressure roller.
- (9) Slide the lower rear nip release link in the direction of the arrow 9b while pulling it in the direction of the arrow 9a to remove the rear nip release link.
- (10) Remove the taptite pan B M4x14 screw. Release the hook, and remove the fuser unit line cover L.

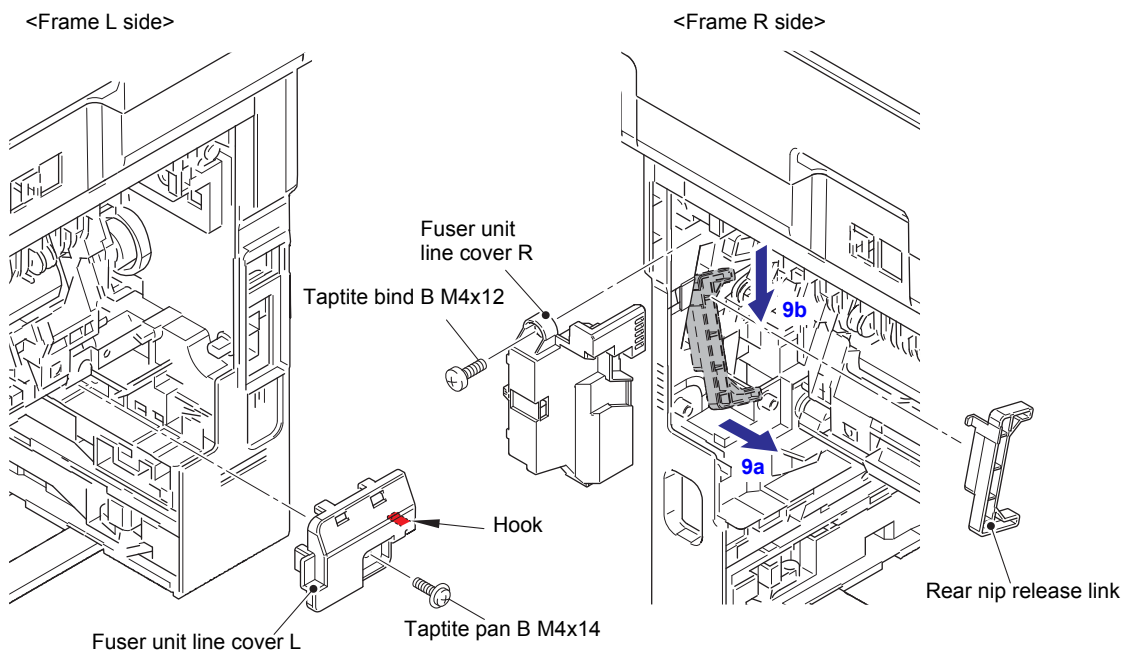

Fig. 7-5

- (11) Release the heater harness of the fuser unit from the securing fixtures, and disconnect it from the low-voltage heater harness.

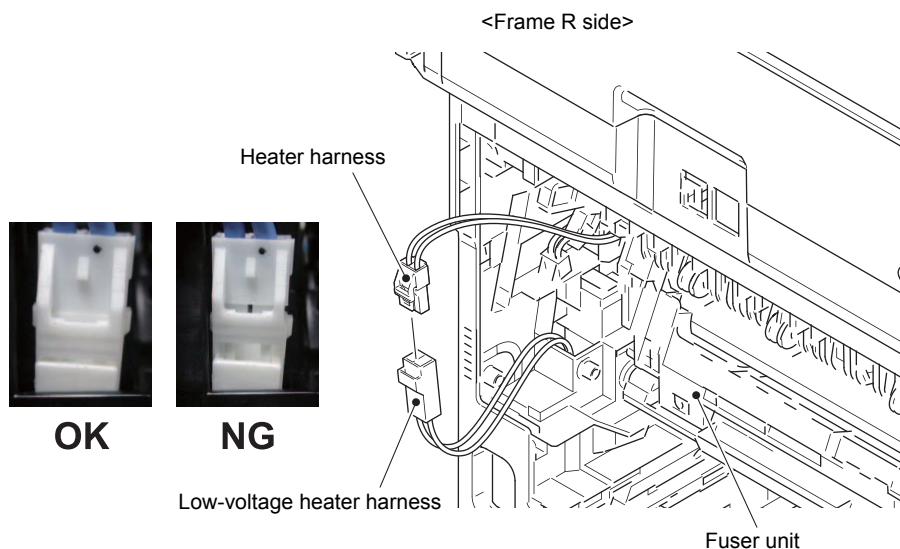

Fig. 7-6

Assembling Note:

- After connecting the heater harness, pull the connector on the heater harness side while holding the connector on the low-voltage heater harness side to make sure it is locked.

Harness routing: Refer to "11. Rear side of the machine".

- (12) Disconnect the center thermistor harness and the side thermistor harness from the eject sensor PCB ASSY.

Note:

- When disconnecting the harness, hold the top of the PCB connector to prevent the PCB connector being damaged.

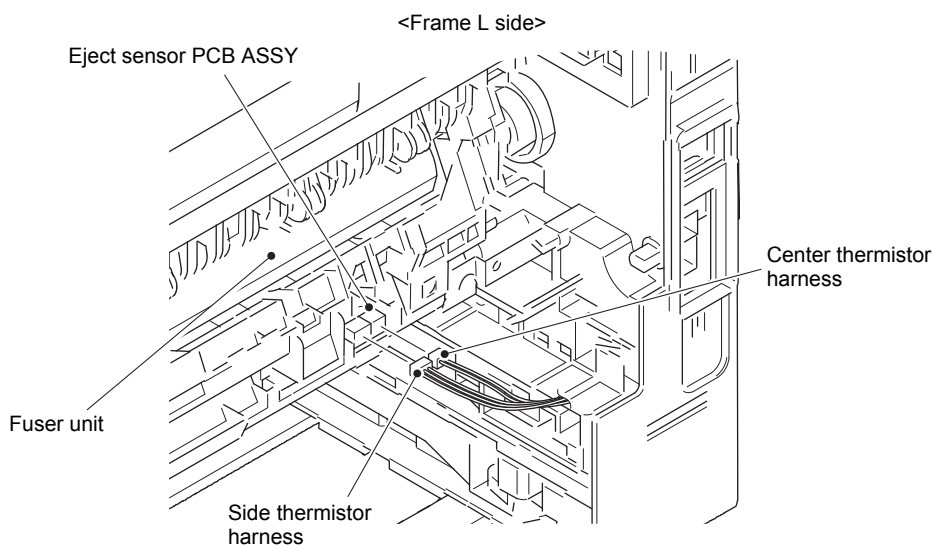

Fig. 7-7

Harness routing: Refer to "11. Rear side of the machine".

(13) Close the front cover and return the pressure roller nip.

(14) Remove the taptite pan B M4x14 screw, and remove the fuser unit.

Note:

- Make sure that the front cover is closed when removing the fuser unit.

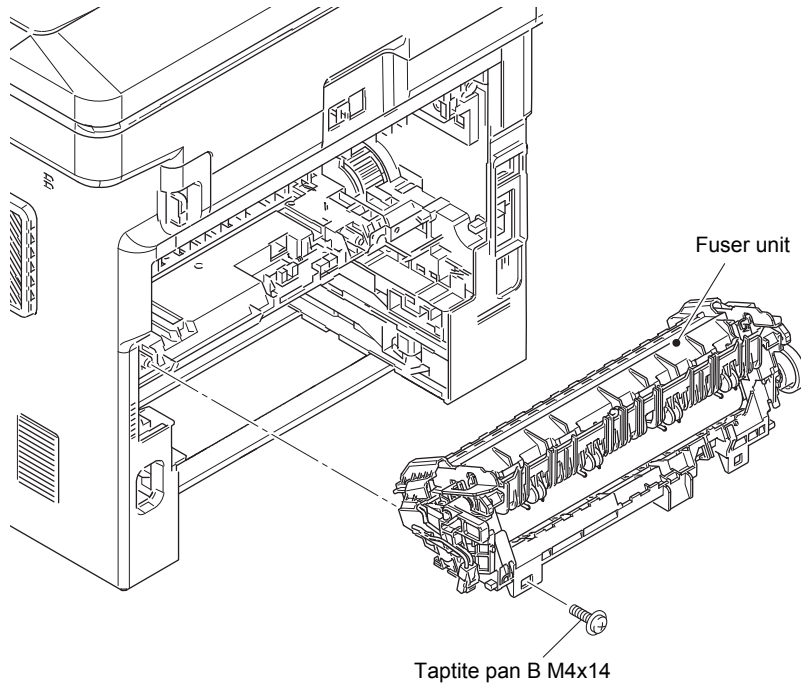

Fig. 7-8

2.3 Laser unit

- (1) Open the back cover.
- (2) Remove the two taptite bind B M4x12 screws.

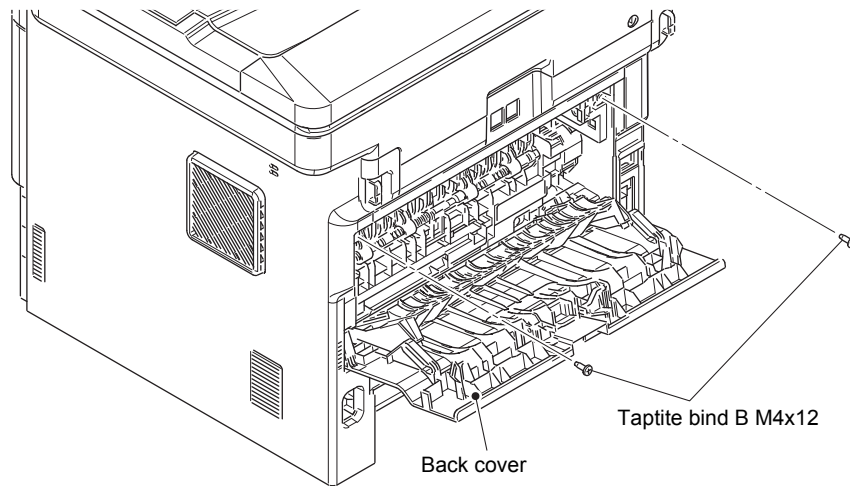

Fig. 7-9

- (3) Remove the two taptite bind B M4x12 screws.
- (4) Push the front cover release button, and open the front cover.

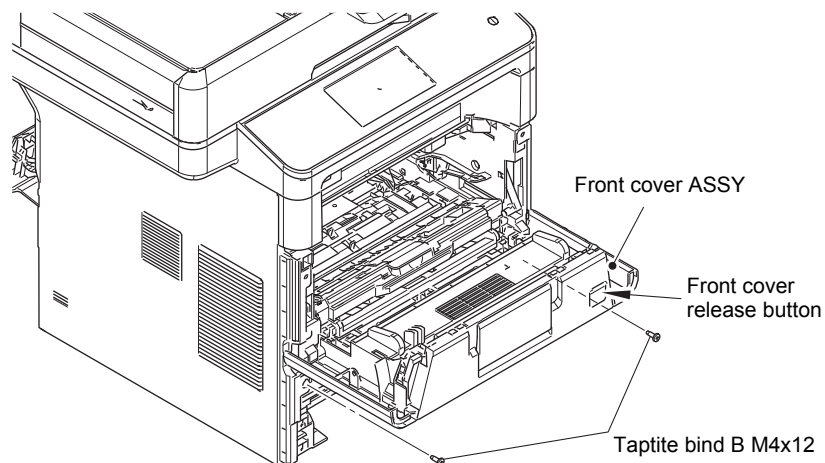

Fig. 7-10

(5) Release the hook A, B and C of the arrow A to C in this order, and remove the side cover L.

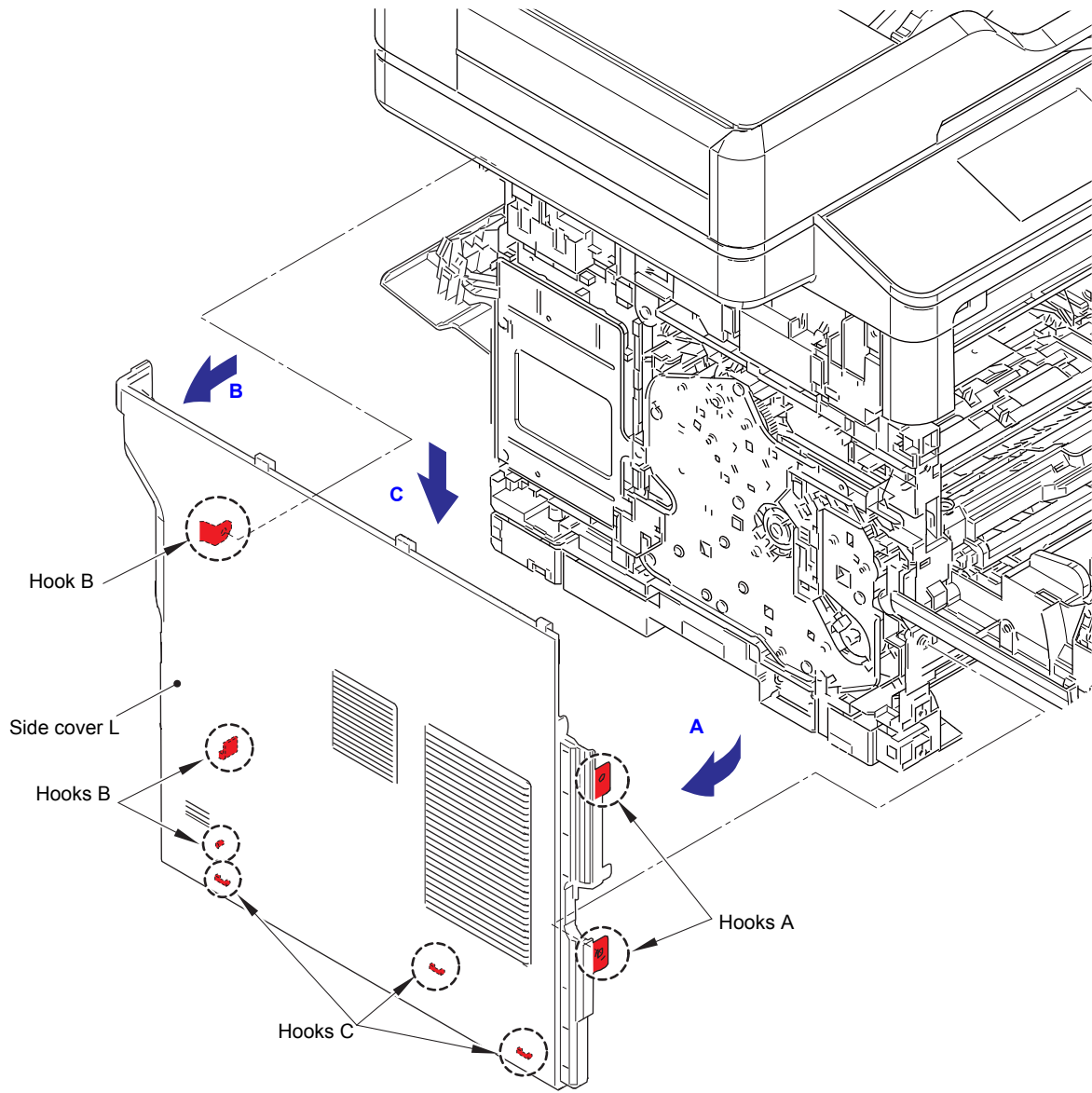

Fig. 7-11

(6) Release the hook A, B and C of the arrow A to C in this order, and remove the side cover R.

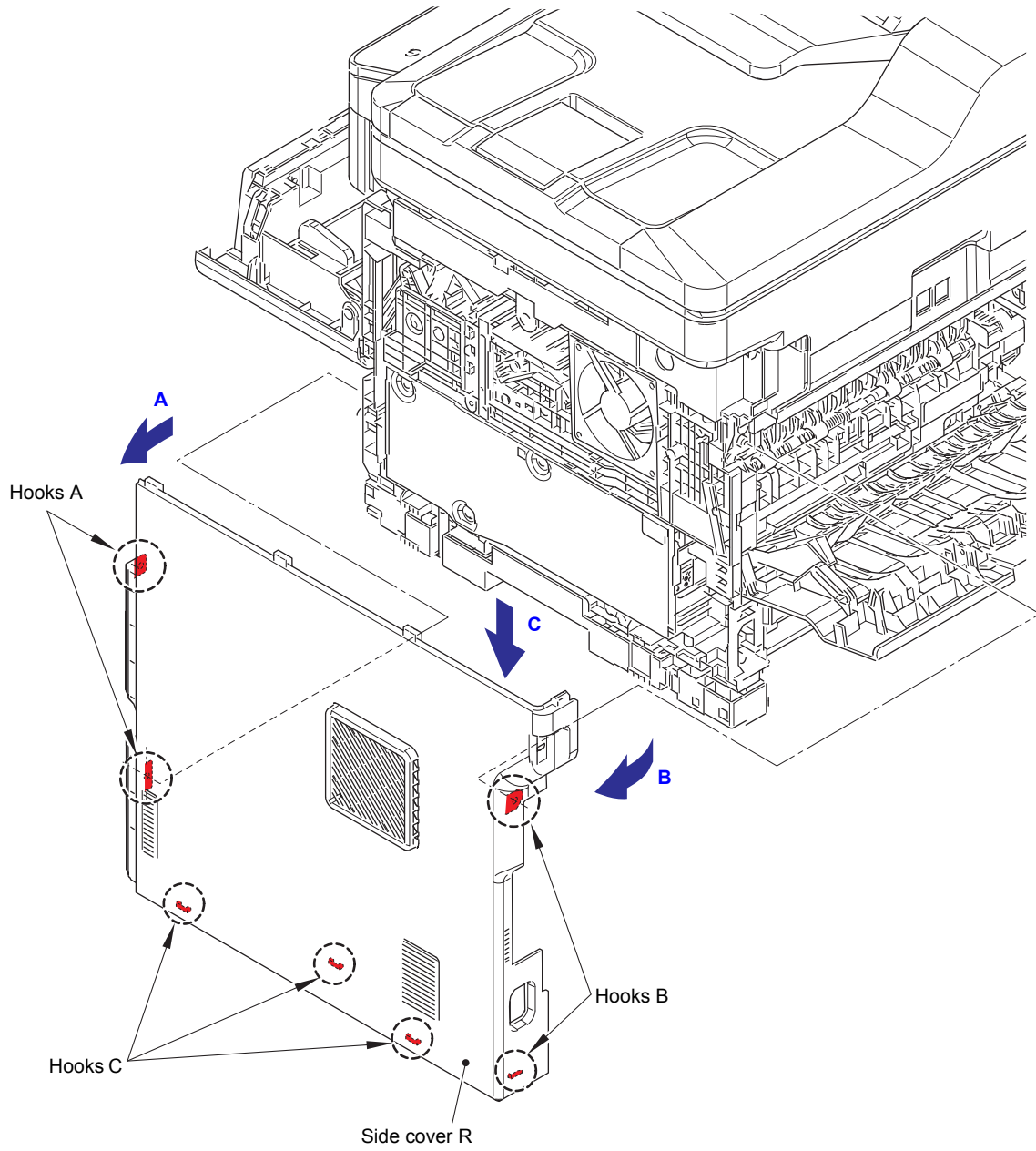

Fig. 7-12

(7) Remove the tape to remove the modem FG harness L from the main shield plate.

Assembling Note:

- Attach the modem FG harness L on the right side than "A" using a tape.

(8) Remove the three screw cup M3x8 screws (Black), and remove the ADF FG harness, FB FG harness, modem FG harness L and main shield plate.

(9) Remove the taptite cup S M3x8 SR screw, and remove the panel FG harness.

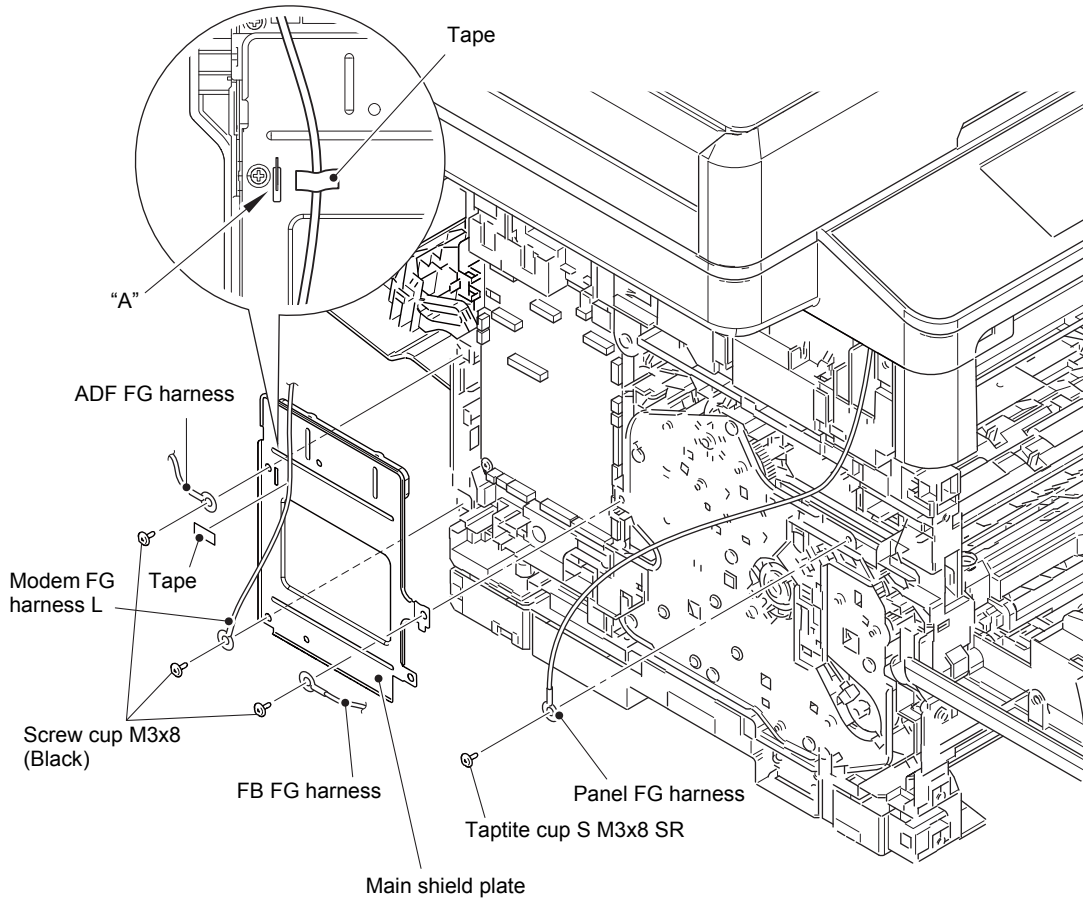

Fig. 7-13

Harness routing: Refer to "1. ADF unit - Main PCB ASSY", "2. Document scanner unit - Main PCB ASSY".

- (10) Disconnect the FB motor harness and ADF sensor harness from the main PCB ASSY. Open the main PCB insulation sheet, and release each harness from the securing fixtures. Release each FG harness from the securing fixtures.
- (11) Disconnect the panel flat cable from the main PCB ASSY, and release it from the securing fixtures.
- (12) Disconnect the first side CIS flat cable and second side CIS flat cable* from the main PCB ASSY, and release them from the securing fixtures.
- (13) Remove the guide sponge from the second side CIS flat cable.

Note:

- While disconnecting the second side CIS flat cable, take off the guide sponge as it is obstructive.
- Be sure to replace the guide sponge with a new one, after taking off the guide sponge from the second side CIS flat cable.

- (14) Disconnect the USB host harness from the main PCB ASSY, and release it from the securing fixtures.

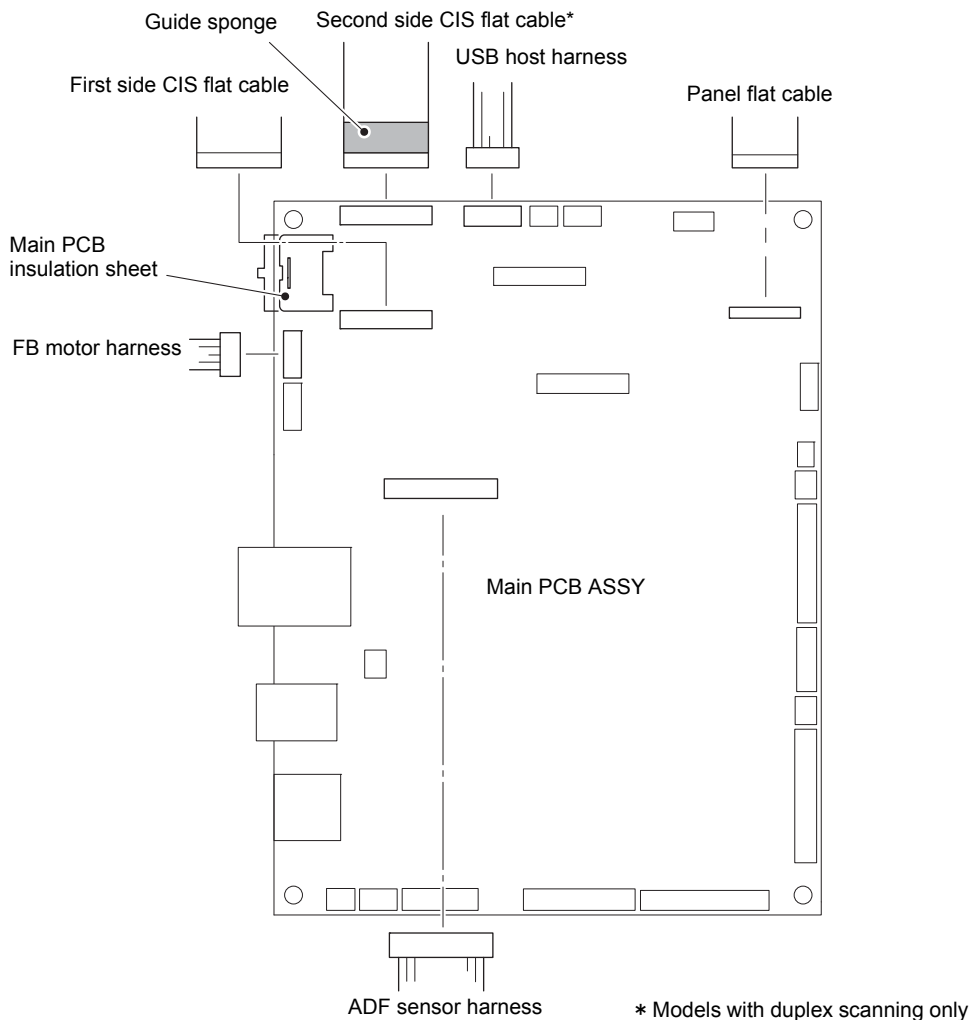

Fig. 7-14

Harness routing: Refer to "1. ADF unit - Main PCB ASSY", "2. Document scanner unit - Main PCB ASSY", "3. Left side of the machine".

(15) Remove the six taptite bind B M4x12 screws. Release each hook to remove the ADF/document scanner unit.

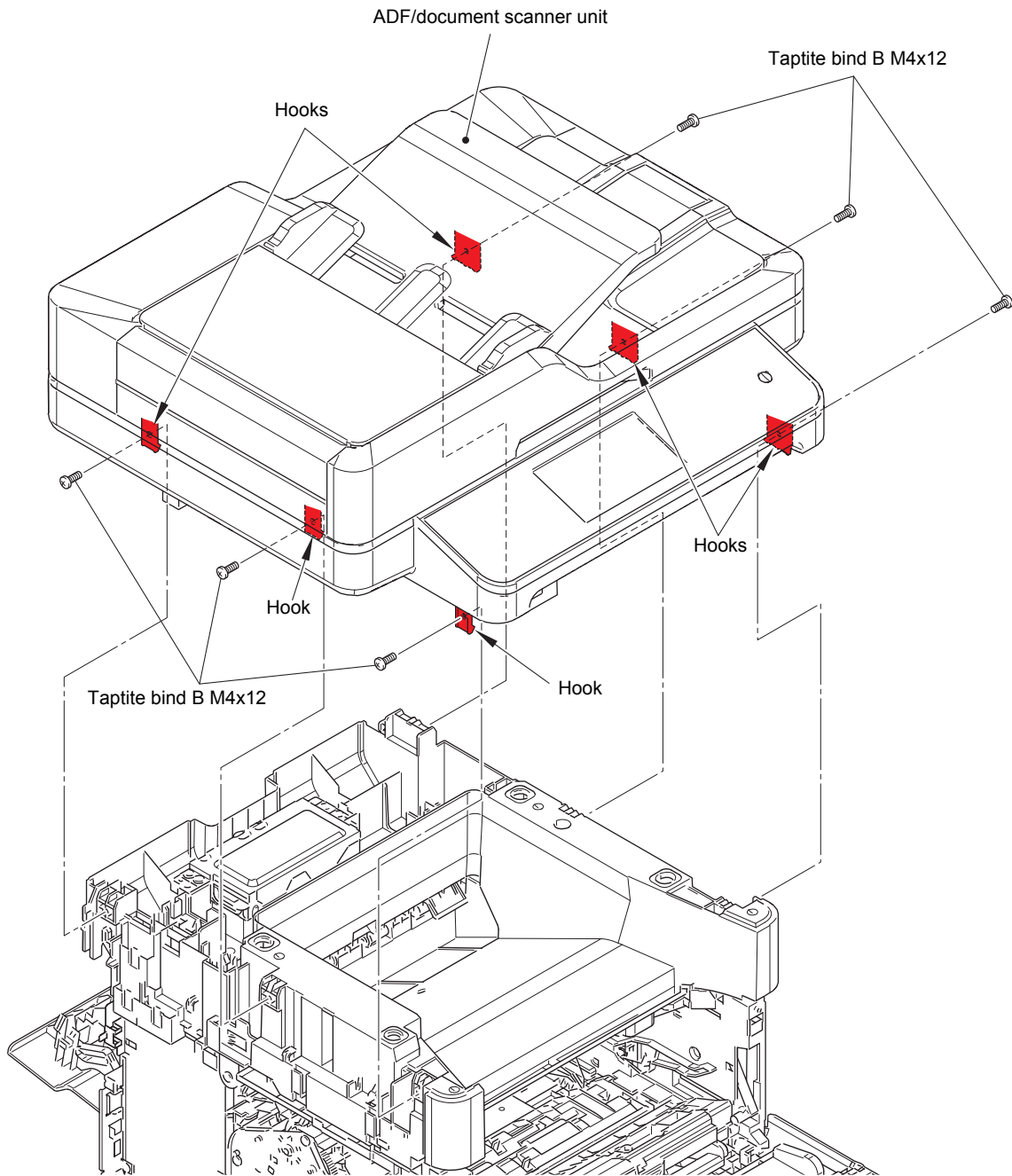
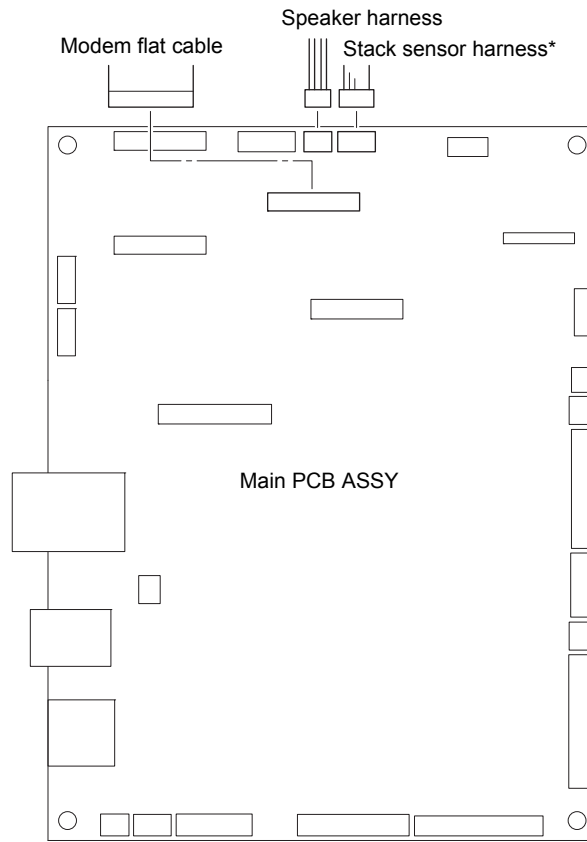

Fig. 7-15

(16) Disconnect the modem flat cable, speaker harness, and stack sensor harness* from the main PCB ASSY.



* Models with USB host on the rear side only

Fig. 7-16

Harness routing: Refer to "3. Left side of the machine", "10. Left side of the machine".

- (17) Remove the taprite cup S M3x8 SR screw, and disconnect the modem FG harness R. Disconnect the modem FG harness R from the securing fixtures of the hold cover 1.
- (18) Remove the six taprite bind B M4x12 screws. Release each hook to remove the joint cover ASSY.

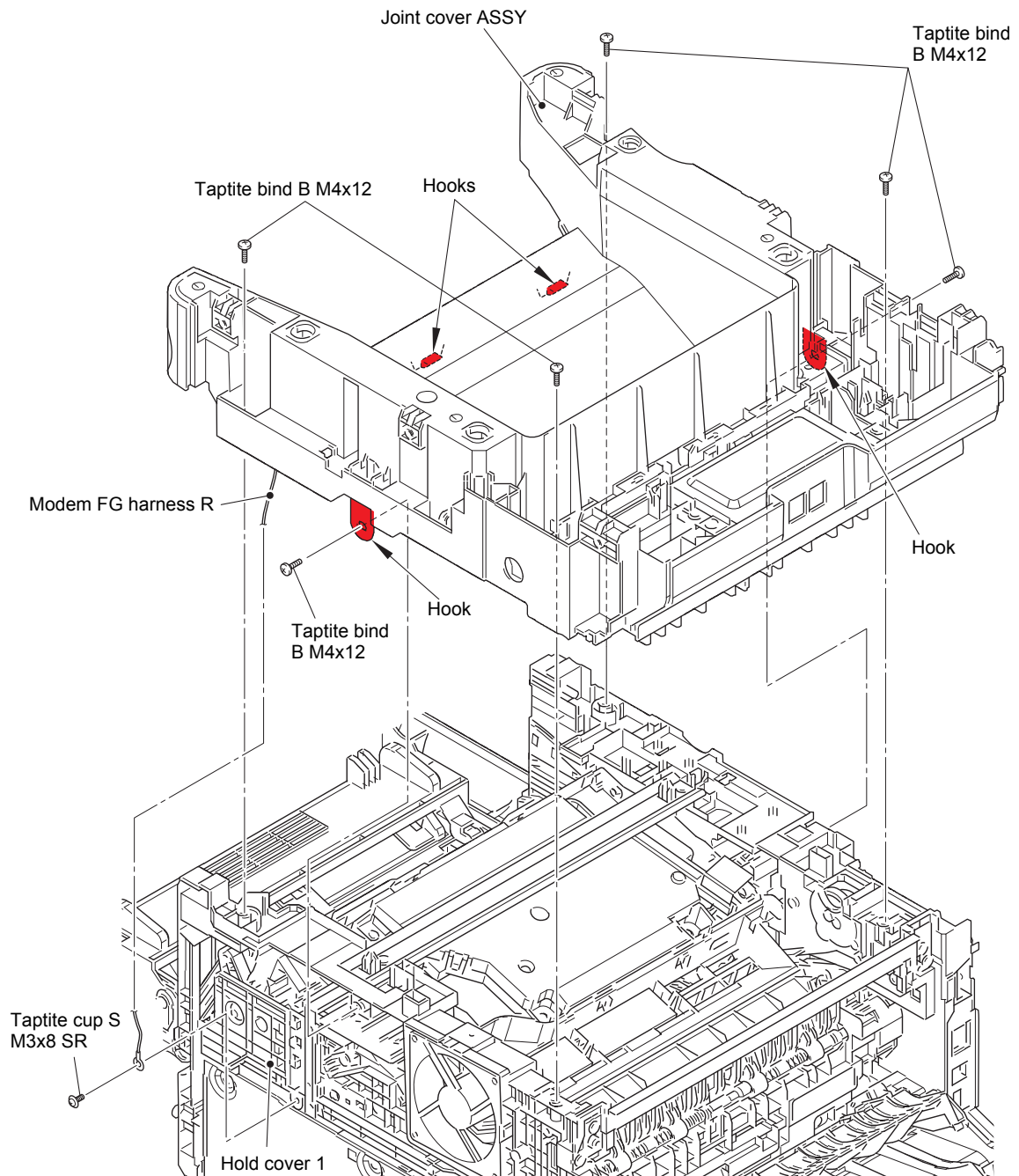

Fig. 7-17

Harness routing: Refer to "9. Speaker unit, Modem (LVPS side)".

Assembling Note:

- When assembling the joint cover ASSY, be careful not to damage the wireless LAN PCB.

- (19) Remove the two taptite bind B M4x12 screws, and remove the top bar. (Models with 520-sheet T1 only)
- (20) Disconnect the laser unit flat cable from the laser unit, and release it from the securing fixtures.
- (21) Remove the four taptite cup S M3x8 SR screws, and remove the laser unit.

Note:

- Be careful not to touch the lens of the laser unit.

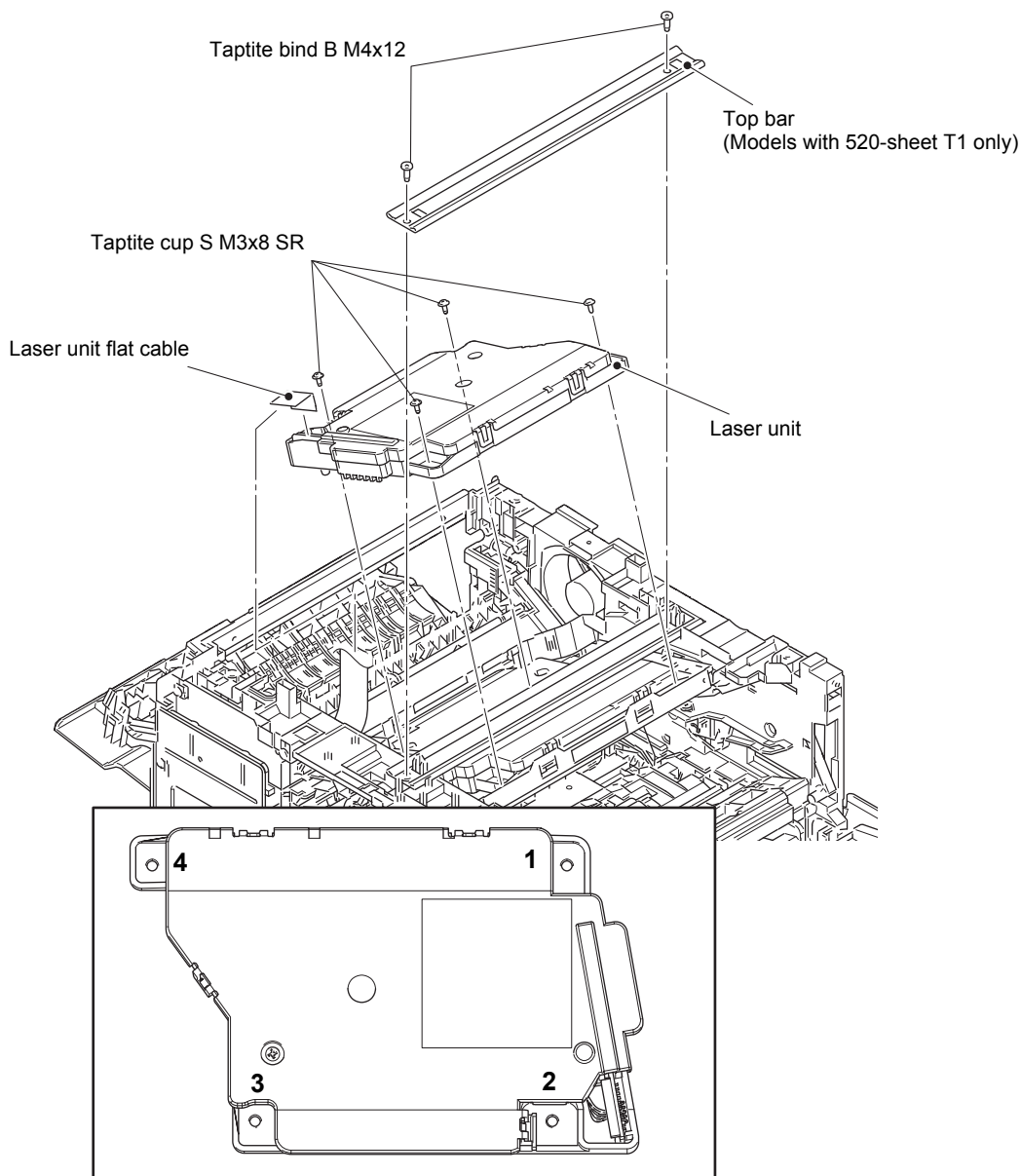

Fig. 7-18

Harness routing: Refer to “10. Left side of the machine”, “11. Rear side of the machine”.

Assembling Note:

- When attaching the laser unit, tighten the screws in the following order: upper right, lower right, lower left and upper left.
- When connecting flat cables, do not insert them at an angle. After insertion, check that the cable is not at an angle.

< Location of the laser serial number on the laser unit >

Note:

- Attach the laser serial label to the position (on the laser plate) shown in the figure below after replacing the laser unit.

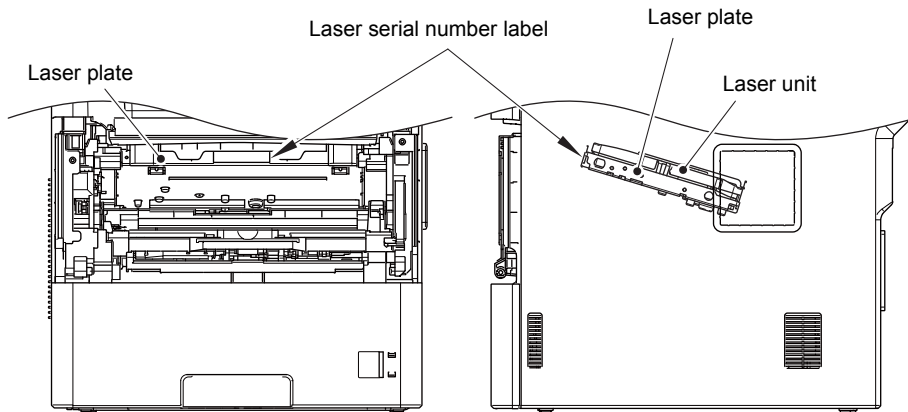

Fig. 7-19

2.4 PF kit MP

- (1) Push the front cover release button, and open the front cover ASSY.
- (2) Open the MP roller cover. Release the hook on the MP holder bushing, and slide the MP holder bushing in the direction of the arrow 2.
- (3) Slide the MP roller holder ASSY in the direction of the arrow 3 to remove it from the MP separation roller shaft. Then remove the MP roller holder ASSY.
- (4) Raise the MP separation pad ASSY to the 50-degree position, and remove it in the direction of the arrow 4.
- (5) Remove the MP separation pad spring.

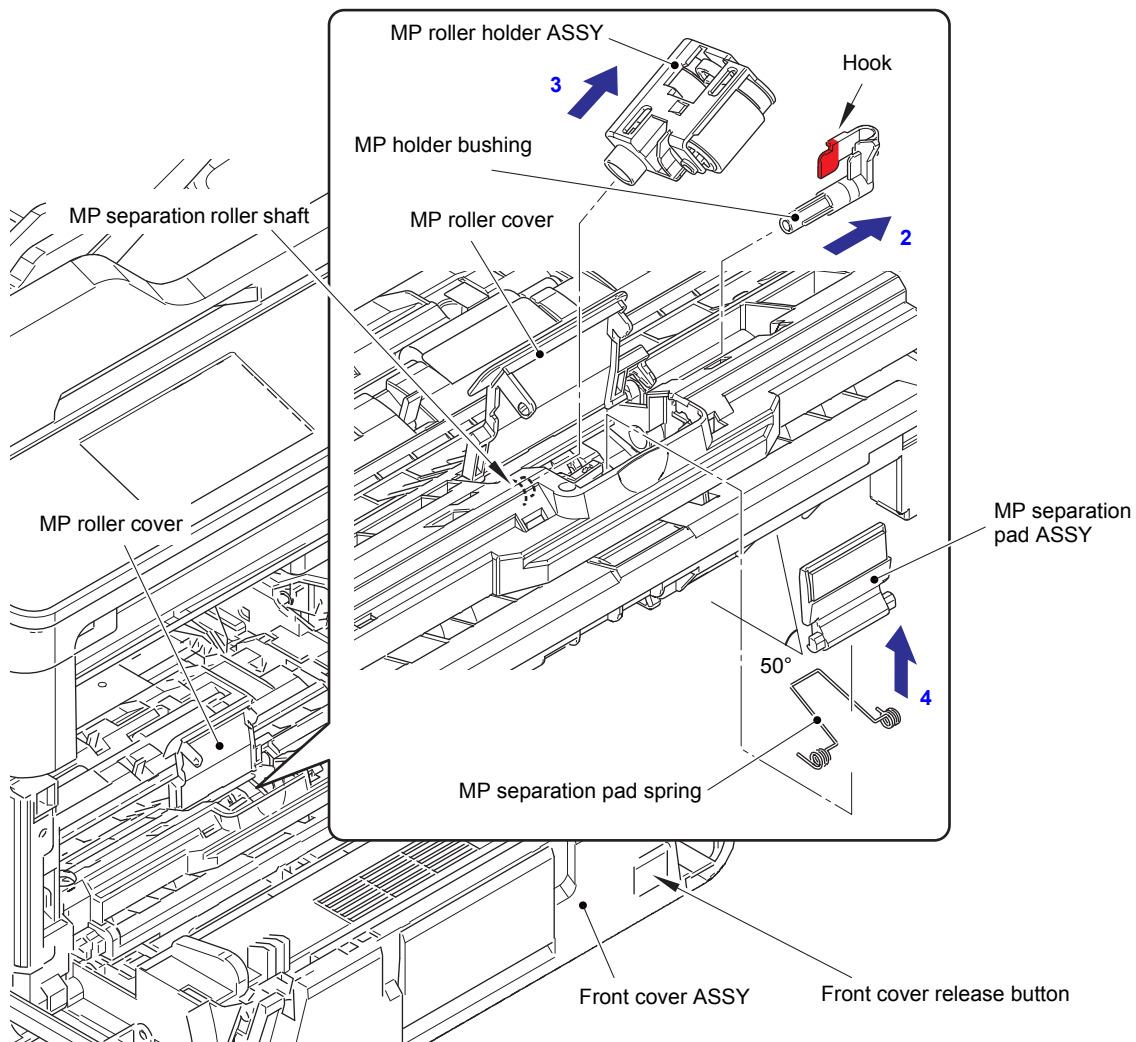

Fig. 7-20

Assembling Note:

- Attach the MP roller holder ASSY while pushing the MP separation pad ASSY.

2.5 PF kit 1

- (1) Release the two hooks on the T1 separation pad ASSY from paper tray.
- (2) Push both arms on the T1 separation pad ASSY inwards to remove both pins, and remove the T1 separation pad ASSY from the paper tray.
- (3) Remove the T1 separation pad spring from the T1 separation pad ASSY.

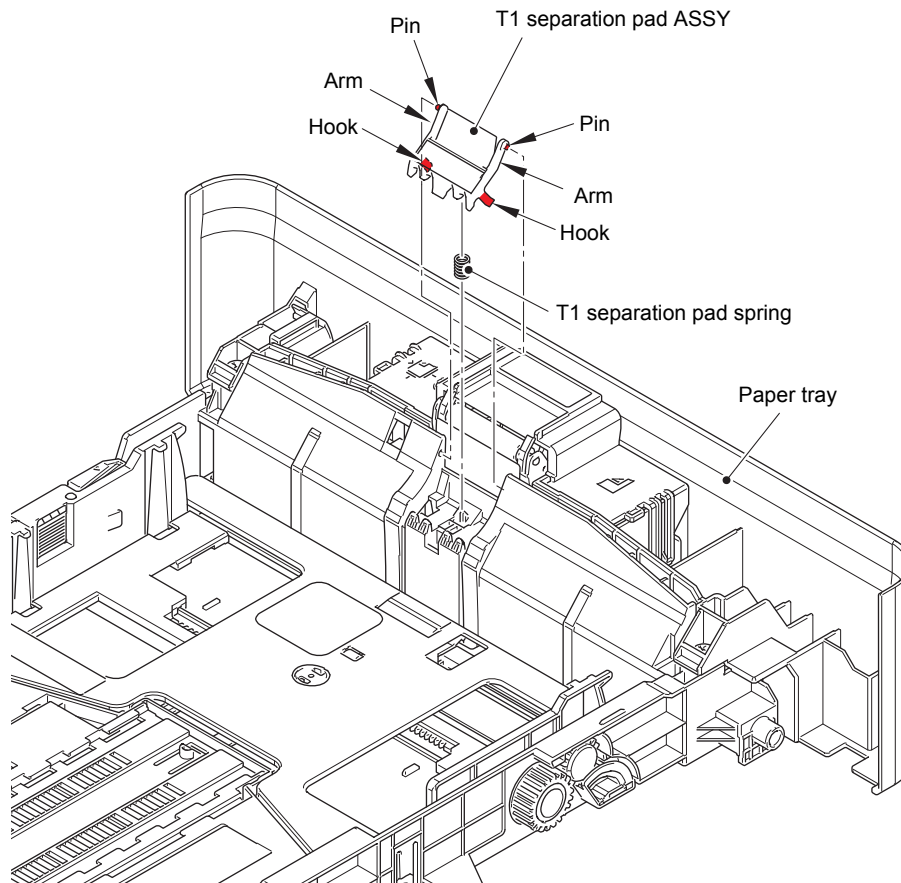

Fig. 7-21

- (4) Push the link arm in the direction of the arrow A, and turn the T1 roller holder ASSY to remove the boss.
- (5) Slide the T1 roller holder ASSY in the direction of the arrow B to remove it from the shaft, and remove the T1 roller holder ASSY.

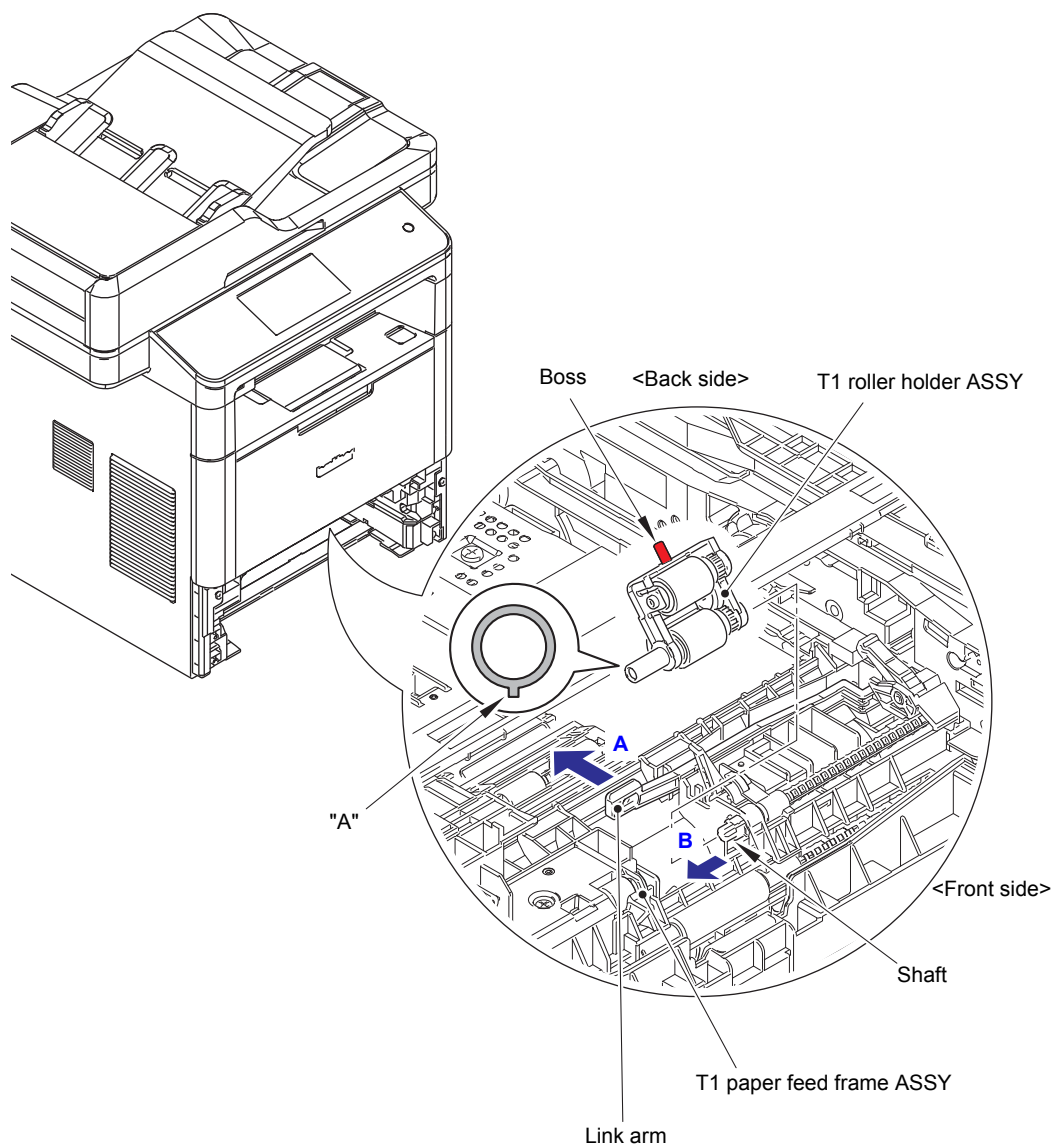

Fig. 7-22

Assembling Note:

- When attaching the T1 roller holder ASSY, engage "A" on the shaft of the T1 roller holder ASSY with the hole on the T1 paper feed frame ASSY, and insert the shaft into the hole.

2.6 PF kit 2/3/4/5

Note:

- Disassembly procedures of the PF kit are common to LT and TT.

- (1) Release the two hooks on the separation pad ASSY from the paper tray.
- (2) Push both side arms on the separation pad ASSY inwards to remove the pins, and remove the separation pad ASSY from the paper tray.
- (3) Remove the separation pad spring from the separation pad ASSY.

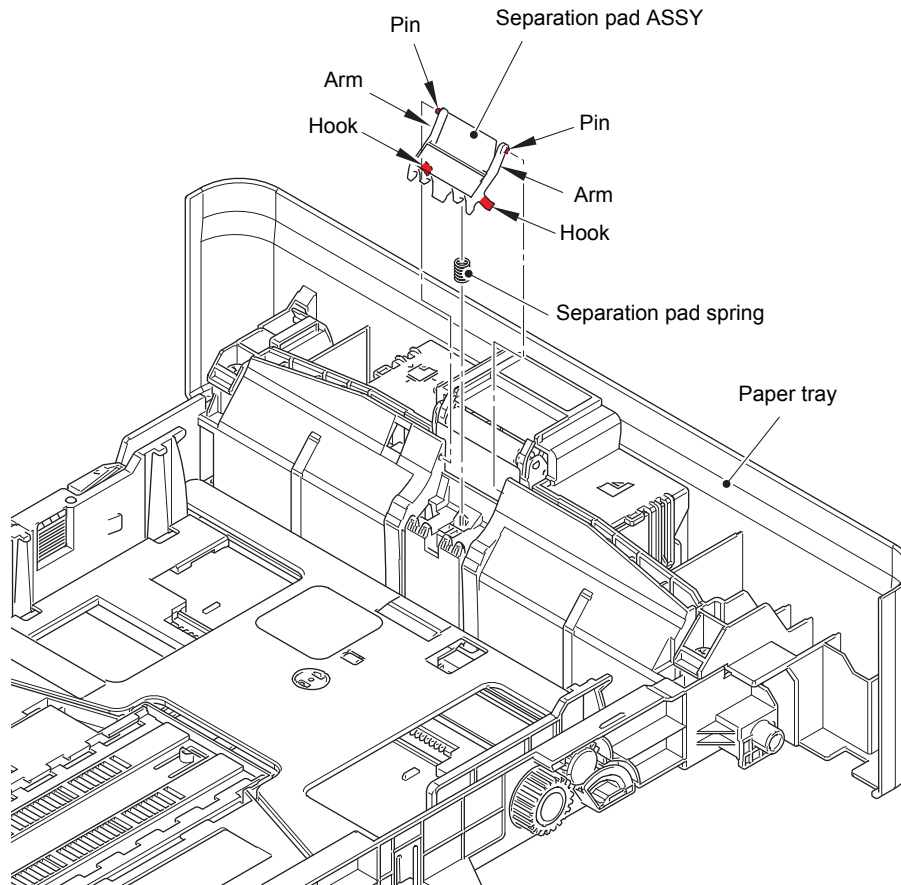

Fig. 7-23

- (4) Push the link arm in the direction of the arrow A, and turn the roller holder ASSY to remove the boss.
- (5) Slide the roller holder ASSY in the direction of the arrow B to remove it from the shaft, and remove the roller holder ASSY.

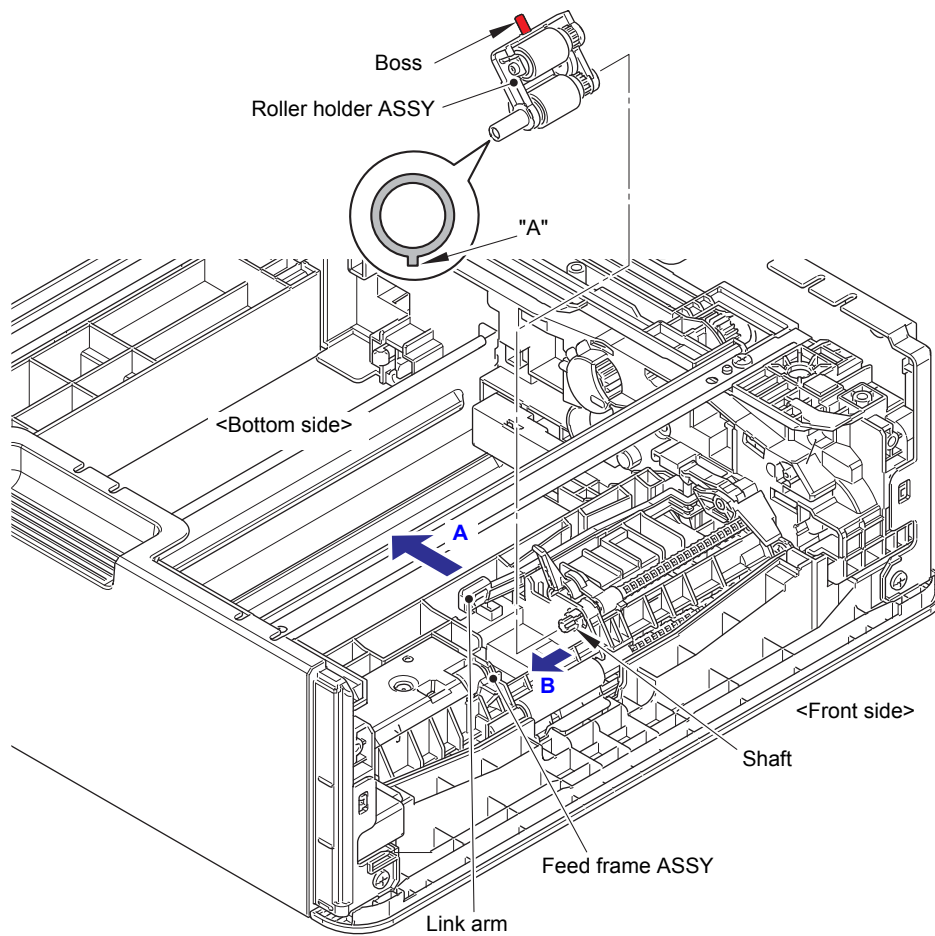

Fig. 7-24

Assembling Note:

- When attaching the roller holder ASSY, engage "A" on the shaft of the roller holder ASSY with the hole on the feed frame ASSY, and insert the shaft into the hole.

APPENDIX 1 SERIAL NUMBERING SYSTEM

Serial number labels on the printer

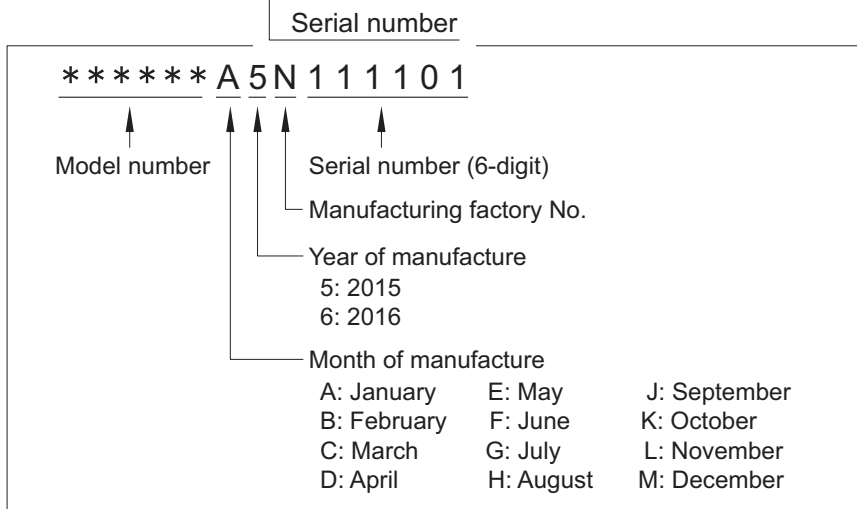
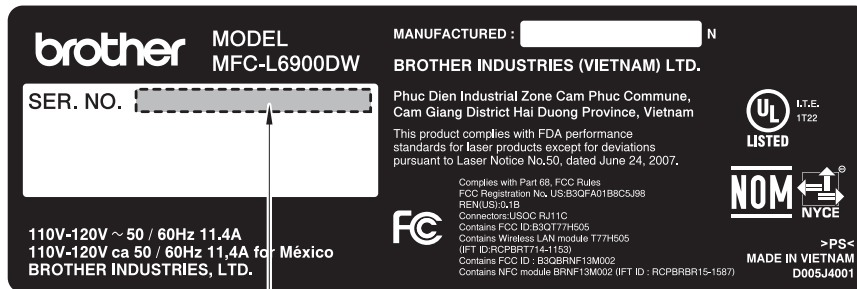

Fig. App. 1-1

<Location>

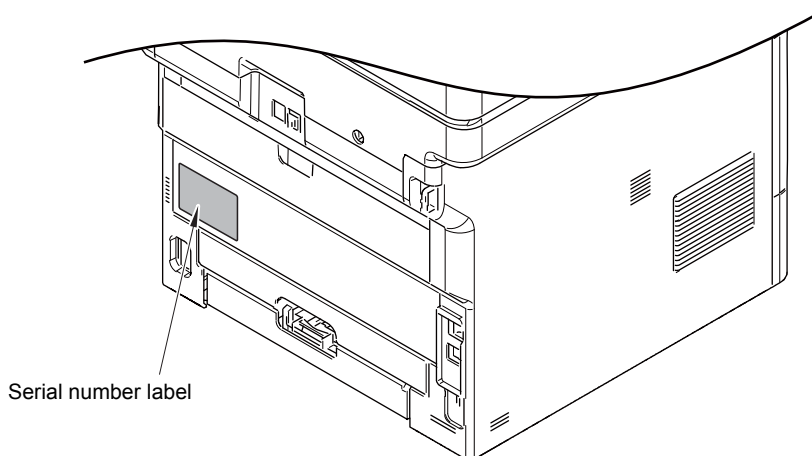



Fig. App. 1-2

APPENDIX 2 DELETING USER SETTING INFORMATION

The user setting information for the machine is stored in the main PCB. You can return this to the default settings by following the procedure below.

<Operating Procedure>

- (1) Press the [Settings]  key while the machine is in the ready state.
- (2) Press the [All Settings] key on the LCD.
- (3) Press the [Initial Setup] key on the LCD.
- (4) Press the [Reset] key on the LCD.
- (5) Press the [Factory Reset] key on the LCD.
- (6) "Factory Reset? It may take time until reset finishes. Yes No" appears on the LCD. Press the [Yes] key.
- (7) "Machine will reboot after resetting. Press [OK] for 2 seconds to confirm." appears on the LCD. Press and hold the [OK] key for 2 seconds or longer to delete the user setting information and return the machine to the ready state.

APPENDIX 3 INSTALLING THE MAINTENANCE PRINTER DRIVER

To identify machines connected via USB direct interface, the computer requires the corresponding driver for the virtual USB device. If you connect any number of machines to your computer, the same number of virtual USB devices will be automatically configured on your computer. To prevent many virtual USB devices from being configured, use the unique driver installation procedure described below that enables your computer to identify terminals via one single virtual USB device.

Note:

- Once this installation procedure is carried out for a computer, no more driver/software installation will be required for that computer to identify machines. If the Brother Maintenance USB Printer driver has been already installed to your computer according to this procedure, skip this section.
- Before proceeding to the procedure given below, make sure that the Brother Maintenance USB Printer driver is stored in your computer.

■ Windows XP

- (1) Check that the power switch of the machine is turned OFF. Disconnect the USB cable that connects the machine with your computer.
- (2) Turn ON your computer.
- (3) Turn ON the power switch of the machine.
- (4) Enter the maintenance mode.
(Refer to “1.1 How to Enter Maintenance Mode” in Chapter 5.)
- (5) Connect the machine to your computer using a USB cable.
The following window appears.

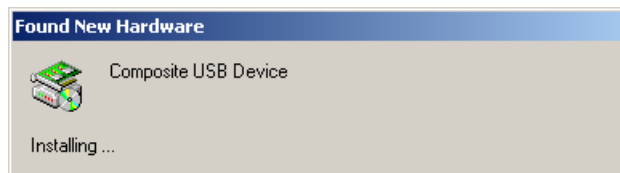

- (6) The following screen appears, indicating the detection of new hardware device by the system. Select “No, not this time.” And click [Next].



(7) Select "Install the software automatically (Recommended)" and click [Next].

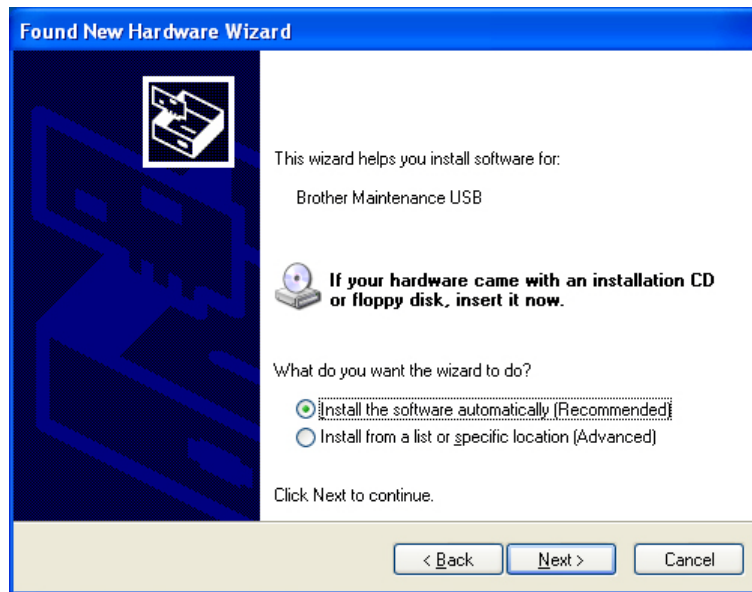

(8) Alert warning message of WHQL appears. Click [Continue Anyway] to proceed.



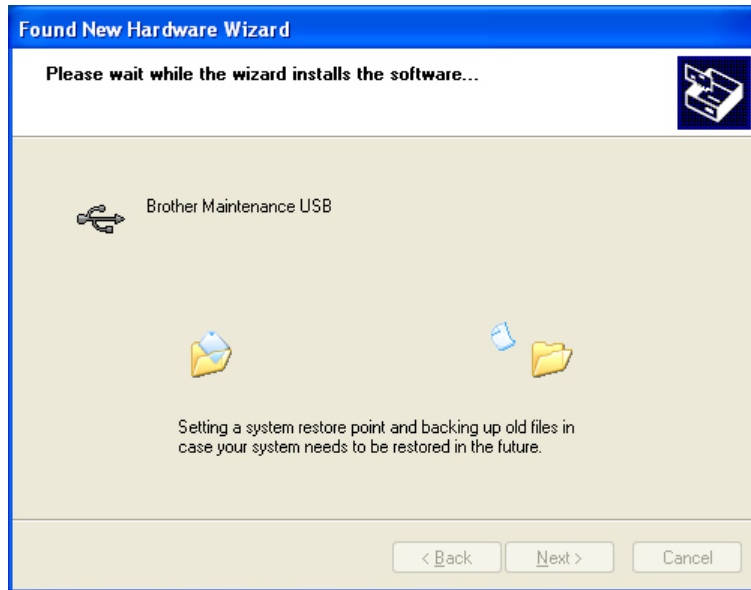

(9) Repeat steps (6) to (8) three times. Installation is completed.

(10) If the Brother Maintenance USB Printer driver is successfully installed, the following message screen appears. Click [Finish] to return.



Note:

In order to check whether the printer driver is successfully installed, click [Start], [Settings], [Printers] to select the Printers window. Then, check that the Brother Maintenance USB Printer icon is shown.

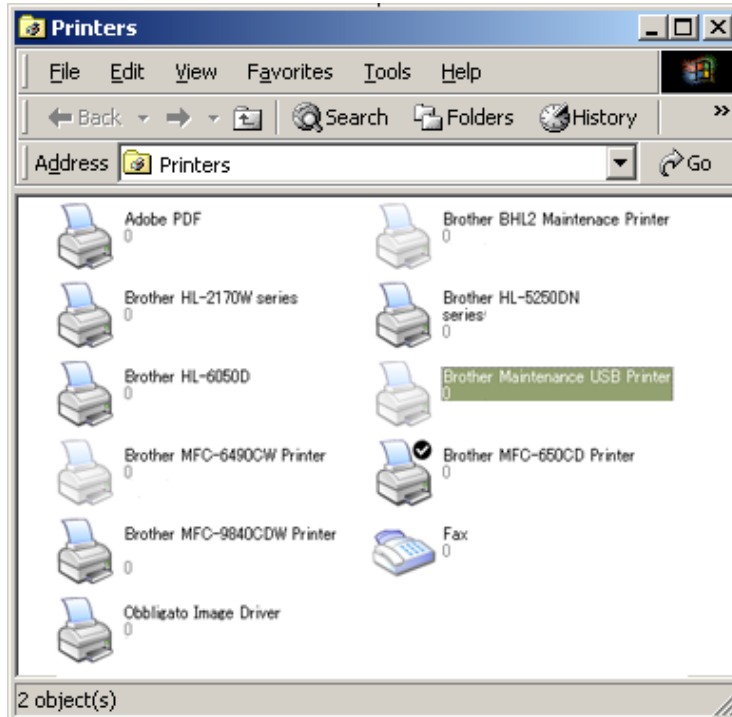

■ **Windows Vista/Windows 7/Windows 8/Windows 8.1/Windows 10**

- (1) Check that the AC cord of the machine is unplugged from the electrical outlet. Disconnect the USB cable that connects the machine with your computer.
- (2) Turn ON your computer.
- (3) Double-click Setup.exe inside the Brother Maintenance USB Printer folder that was saved in a temporary folder. The following screen appears. Click the [Next] button.



The following screen is displayed during installation.

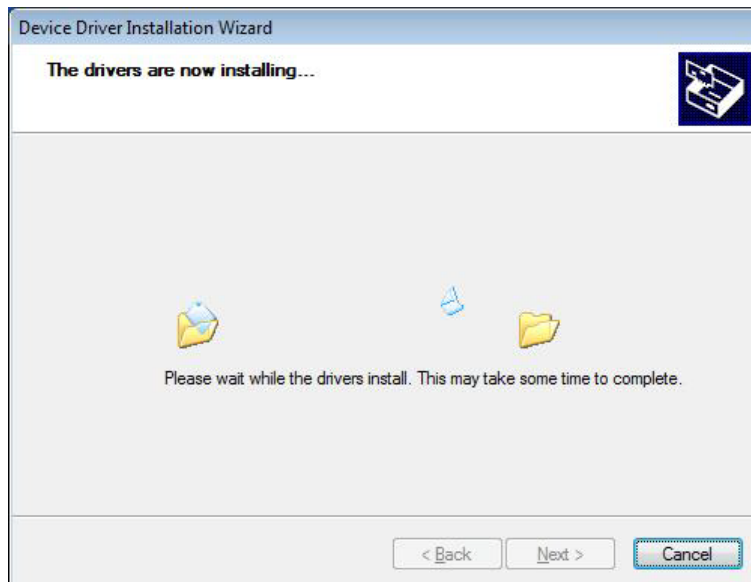

- (4) Wait for the following screen to appear and click [Finish].



- (5) Plug the AC cord of the machine into an electrical outlet.
- (6) Enter the maintenance mode.
(Refer to "1.1 How to Enter Maintenance Mode" in Chapter 5.)
- (7) Connect the machine to your computer using a USB cable and the installation will be performed automatically.