

# RICOH



M154/M155/M174/M175/  
M0A7/M287/M0BB

## ***SERVICE MANUAL***

**LANIER RICOH SAVIN®**

It is the reader's responsibility when discussing the information contained within this document to maintain a level of confidentiality that is in the best interest of Ricoh USA, Inc. and its member companies.

***NO PART OF THIS DOCUMENT MAY BE REPRODUCED IN ANY FASHION AND DISTRIBUTED WITHOUT THE PRIOR PERMISSION OF RICOH USA, Inc.***

All product names, domain names or product illustrations, including desktop images, used in this document are trademarks, registered trademarks or the property of their respective companies.

They are used throughout this book in an informational or editorial fashion only and for the benefit of such companies. No such use, or the use of any trade name, or web site is intended to convey endorsement or other affiliation with Ricoh products.

## **WARNING**

*The Service Manual contains information regarding service techniques, procedures, processes and spare parts of office equipment distributed by Ricoh USA, Inc. Users of this manual should be either service trained or certified by successfully completing a Ricoh Technical Training Program.*

*Untrained and uncertified users utilizing information contained in this service manual to repair or modify Ricoh equipment risk personal injury, damage to property or loss of warranty protection.*

*Ricoh USA, Inc.*

# LEGEND

<b>PRODUCT CODE</b>	<b>MODEL NAME</b>
M154	SP 311DN
M155	SP 311DNw
M174	SP 310DN
M175	SP 311DNw
M0A7	SP 320DN
M287	SP 325DNw
M0BB	SP 377DNwX

# DOCUMENTATION HISTORY

<b>REV. NO.</b>	<b>DATE</b>	<b>COMMENTS</b>
*	02/2017	Original Printing

# M154/M155/M174/M175/ M0A7/M287/M0BB

## TABLE OF CONTENTS

<b>1. PRODUCT INFORMATION .....</b>	<b>1-1</b>
1.1 PRODUCT OVERVIEW .....	1-1
1.1.1 COMPONENT LAYOUT.....	1-1
1.1.2 PAPER PATH.....	1-2
1.1.3 DRIVE LAYOUT.....	1-2
1.2 MACHINE CODES AND PERIPHERALS CONFIGURATION.....	1-3
1.2.1 MAIN FRAME .....	1-3
<b>2. INSTALLATION .....</b>	<b>2-1</b>
2.1 INSTALLATION REQUIREMENTS.....	2-1
2.1.1 CHECK IMAGE QUALITY / SETTINGS.....	2-1
Environment.....	2-1
2.1.2 MOVING AND TRANSPORTING THE MACHINE .....	2-2
<b>3. PREVENTIVE MAINTENANCE.....</b>	<b>3-1</b>
3.1 PREVENTIVE MAINTENANCE TABLES .....	3-1
3.2 IMAGE QUALITY STANDARDS.....	3-2
3.3 PAPER TRANSFER QUALITY STANDARDS .....	3-3
3.4 PM PARTS SETTINGS .....	3-4
3.4.1 PM PARTS.....	3-4
3.5 PREPARATION FOR PM .....	3-5
3.5.1 YIELD COUNTER.....	3-5
Counter Reset.....	3-6
<b>4. REPLACEMENT AND ADJUSTMENT.....</b>	<b>4-1</b>
4.1 GENERAL CAUTIONS.....	4-1
4.2 SPECIAL TOOLS .....	4-2
4.3 EXTERIOR COVERS.....	4-3
4.3.1 FRONT COVER.....	4-3
4.3.2 LEFT COVER .....	4-5
4.3.3 REAR COVER .....	4-7
4.3.4 RIGHT COVER .....	4-8
4.3.5 TOP COVER .....	4-10
When installing the top cover .....	4-11

4.4	LASER UNIT .....	4-12
4.4.1	CAUTION DECAL LOCATIONS.....	4-12
4.4.2	LASER UNIT .....	4-13
4.4.3	POLYGON MIRROR MOTOR.....	4-14
4.5	PAPER FEED.....	4-15
4.5.1	PAPER FEED ROLLER .....	4-15
	After installing a new paper feed roller .....	4-15
4.5.2	FRICTION PAD.....	4-16
	When reinstalling the friction pad, do it in this order:.....	4-16
4.5.3	PAPER END SENSOR .....	4-16
4.5.4	BY-PASS FEED ROLLER .....	4-17
4.5.5	BY-PASS FEED ROLLER FRICTION PAD .....	4-18
4.5.6	BY-PASS FEED SENSOR .....	4-19
4.5.7	PAPER FEED CLUTCH.....	4-19
4.5.8	RELAY CLUTCH.....	4-20
4.5.9	REGISTRATION CLUTCH.....	4-20
4.5.10	REGISTRATION ROLLER .....	4-21
4.5.11	REGISTRATION SENSOR .....	4-24
4.6	IMAGE TRANSFER.....	4-25
4.6.1	TRANSFER ROLLER .....	4-25
	After installing a new transfer roller .....	4-25
4.6.2	TONER END SENSOR.....	4-26
4.6.3	QUENCHING LAMP .....	4-27
4.7	FUSING AND EXIT .....	4-28
4.7.1	FUSING UNIT .....	4-28
	Reinstallation .....	4-29
	After installing a new fusing unit.....	4-30
4.7.2	THERMOSTAT.....	4-30
4.7.3	THERMISTOR .....	4-31
4.7.4	FUSING LAMP.....	4-32
	When reinstalling the fusing lamp .....	4-33
4.7.5	HOT ROLLER .....	4-33
4.7.6	PRESSURE ROLLER .....	4-35
4.7.7	HOT ROLLER STRIPPER PAWLS .....	4-36
4.7.8	PAPER EXIT SENSOR .....	4-36
4.8	DRIVE .....	4-37
4.8.1	MAIN MOTOR.....	4-37
4.8.2	DRIVE UNIT.....	4-37
4.8.3	DUPLEX MOTOR .....	4-38

4.9 ELECTRICAL COMPONENTS.....	4-39
4.9.1 LAYOUT OF PC BOARDS.....	4-39
4.9.2 MAIN BOARD .....	4-40
When installing the new main board .....	4-41
EEPROM .....	4-41
4.9.3 PSU .....	4-42
Replacement Procedure M154/M155/M147/M175 .....	4-43
Replacement Procedure M287/M289 .....	4-47
4.9.4 HVP .....	4-48
4.9.5 CHARGE TERMINAL CASE .....	4-50
4.9.6 COOLING FAN .....	4-51
4.9.7 WIRELESS LAN BOARD (FOR M155, M175).....	4-52
4.10 DUPLEX .....	4-53
4.10.1 RELAY SENSOR .....	4-53
4.10.2 INVERTER SENSOR.....	4-53

## **5. SERVICE TABLES ..... 5-1**

5.1 SMART ORGANIZING MONITOR .....	5-1
5.1.1 OVERVIEW.....	5-1
5.1.2 PRINTER DRIVER INSTALLATION (USB CONNECTION) .....	5-1
5.1.3 ENTERING THE PRINTER CONFIGURATION .....	5-2
5.1.4 PRINTER CONFIGURATION MENU LIST .....	5-4
Paper Input .....	5-5
Maintenance .....	5-7
System.....	5-9
IPv6.....	5-12
Network 1.....	5-13
Network 2.....	5-16
Network 3.....	5-18
Wireless .....	5-19
Printer .....	5-21
SP Mode 1 .....	5-23
SP Mode 2 .....	5-26
SP Mode 3 .....	5-28
5.2 REPORTS .....	5-31
5.2.1 CONFIGURATION PAGE .....	5-31
To Print the Configuration Page .....	5-31
Total Counter.....	5-32
5.2.2 OTHER TYPES OF REPORTS.....	5-33
5.2.3 TEST PAGE .....	5-33

To Print the Test Page .....	5-33
5.2.4 TEST PATTERN PRINTING .....	5-34
To Print the Test Pattern .....	5-34
5.3 UPDATING THE FIRMWARE .....	5-36
5.3.1 CHECKING THE MACHINE FIRMWARE VERSION .....	5-36
5.3.2 UPDATING THE MAIN FIRMWARE .....	5-36
Procedure .....	5-36
5.3.3 UPDATING THE BOOT LOADER FIRMWARE .....	5-37
5.3.4 UPDATING FAILURE .....	5-37
5.3.5 FW UPDATE TOOL MESSAGES .....	5-38
FW Update Tool Messages: Information .....	5-38
FW Update Tool Messages: Error .....	5-40

## **6. TROUBLESHOOTING ..... 6-1**

6.1 SELF-DIAGNOSTIC MODE .....	6-1
6.1.1 SELF-DIAGNOSTIC MODE AT POWER ON .....	6-1
6.2 SERVICE CALL .....	6-2
6.2.1 SUMMARY .....	6-2
Fusing related SCs .....	6-2
6.2.2 ENGINE SC .....	6-3
SC 2xx (Laser Optics Error) .....	6-3
SC 4xx (Image Transfer and Transfer Error) .....	6-5
SC 5xx (Motor and Fusing Error) .....	6-6
SC 6xx (Communication and other Errors) .....	6-10
6.3 JAM DETECTION .....	6-11
6.3.1 JAM SENSOR LAYOUT .....	6-11
Paper Jam .....	6-11
6.3.2 JAM MESSAGE LIST .....	6-11
Paper Jam .....	6-12
6.4 IMAGE ADJUSTMENT .....	6-13
6.4.1 REGISTRATION ADJUSTMENT .....	6-13
User Adjustment .....	6-13
Service Adjustment .....	6-13
6.5 IMAGE QUALITY .....	6-16
6.5.1 OVERVIEW .....	6-16
6.6 OTHER PROBLEMS .....	6-17
6.6.1 DARK LINES IN HALFTONE AREAS AT 75MM INTERVALS .....	6-17
6.7 TROUBLESHOOTING .....	6-18
6.7.1 JAM/PAPER FEED PROBLEM .....	6-18
6.7.2 IMAGE QUALITY PROBLEM .....	6-20

<b>7. ENERGY SAVE .....</b>	<b>7-1</b>
7.1 ENERGY SAVE .....	7-1
7.1.1 ENERGY SAVER MODES.....	7-1
Timer Settings.....	7-1
Return to Stand-by Mode .....	7-2
Recommendation.....	7-2
7.2 PAPER SAVE .....	7-3
7.2.1 EFFECTIVENESS OF DUPLEX/COMBINE FUNCTION .....	7-3
1. Duplex:.....	7-3
2. Combine mode:.....	7-3
3.....	7-3
Total counter .....	7-4



# **READ THIS FIRST**

## **Safety Notices**

### **Important Safety Notices**

#### **Prevention of Physical Injury**

1. Before disassembling or assembling parts of the machine and peripherals, make sure that the machine power cord is unplugged.
2. The wall outlet should be near the machine and easily accessible.
3. If any adjustment or operation check has to be made with exterior covers off or open while the main switch is turned on, keep hands away from electrified or mechanically driven components.
4. The machine drives some of its components when it completes the warm-up period. Be careful to keep hands away from the mechanical and electrical components as the machine starts operation.
5. The inside and the metal parts of the fusing unit become extremely hot while the machine is operating. Be careful to avoid touching those components with your bare hands.

#### **Health Safety Conditions**

Toner is non-toxic, but if you get either of them in your eyes by accident, it may cause temporary eye discomfort. Try to remove with eye drops or flush with water as first aid. If unsuccessful, get medical attention.

#### **Observance of Electrical Safety Standards**

The machine and its peripherals must be serviced by a customer service representative who has completed the training course on those models.

#### **Safety and Ecological Notes for Disposal**

1. Do not incinerate toner bottles or used toner. Toner dust may ignite suddenly when exposed to an open flame.
2. Dispose of used toner, the maintenance unit which includes developer or the organic photoconductor in accordance with local regulations. (These are non-toxic supplies.)
3. Dispose of replaced parts in accordance with local regulations.

## **WARNING**

- To prevent a fire or explosion, keep the machine away from flammable liquids, gases, and aerosols. A fire or an explosion might occur.

### **Handling Toner**

- Work carefully when removing paper jams or replacing toner bottles or cartridges to avoid spilling toner on clothing or the hands.
- If toner is inhaled, immediately gargle with large amounts of cold water and move to a well ventilated location. If there are signs of irritation or other problems, seek medical attention.
- If toner gets on the skin, wash immediately with soap and cold running water.
- If toner gets into the eyes, flush the eyes with cold running water or eye wash. If there are signs of irritation or other problems, seek medical attention.
- If toner is swallowed, drink a large amount of cold water to dilute the ingested toner. If there are signs of any problem, seek medical attention.
- If toner spills on clothing, wash the affected area immediately with soap and cold water. Never use hot water! Hot water can cause toner to set and permanently stain fabric.
- Always store toner and developer supplies such as toner and developer packages, cartridges, and bottles (including used toner and empty bottles and cartridges) out of the reach of children.
- Always store fresh toner supplies or empty bottles or cartridges in a cool, dry location that is not exposed to direct sunlight.

## **WARNING**

- Do not use the cleaner to suck spilled toner (including used toner). Sucked toner may cause firing or explosion due to electrical contact flickering inside the cleaner. However, it is possible to use the cleaner designed for dust explosion-proof purpose. If toner is spilled over the floor, sweep up spilled toner slowly and clean remainder with wet cloth.

### **Laser Safety**

The Center for Devices and Radiological Health (CDRH) prohibits the repair of laser-based optical units in the field. The optical housing unit can only be repaired in a factory or at a location with the requisite equipment. The laser subsystem is replaceable in the field by a qualified Customer Engineer. The laser chassis is not repairable in the field. Customer engineers are therefore directed to return all chassis and laser subsystems to the factory or service depot when replacement of the optical subsystem is required.

## **WARNING**

- Use of controls, or adjustment, or performance of procedures other than those specified in this manual may result in hazardous radiation exposure.





## **WARNING**

- Turn off the main switch before attempting any of the procedures in the Laser Optics Housing Unit section. Laser beams can seriously damage your eyes.
- **CAUTION MARKING:**



## **Symbols, Abbreviations and Trademarks**

This manual uses several symbols and abbreviations. The meaning of those symbols and abbreviations are as follows:

	Clip ring
	Screw
	Connector
	Clamp
	E-ring
SEF	Short Edge Feed
LEF	Long Edge Feed

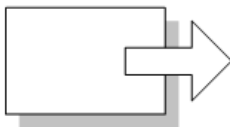

**Short Edge Feed (SEF)**

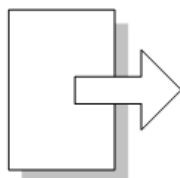

**Long Edge Feed (LEF)**

## **Trademarks**

Microsoft®, Windows®, and MS-DOS® are registered trademarks of Microsoft Corporation in the United States and /or other countries.

PostScript® is a registered trademark of Adobe Systems, Incorporated.

PCL® is a registered trademark of Hewlett-Packard Company.

Ethernet® is a registered trademark of Xerox Corporation.

PowerPC® is a registered trademark of International Business Machines Corporation.

Other product names used herein are for identification purposes only and may be trademarks of their respective companies. We disclaim any and all rights involved with those marks.

# PRODUCT INFORMATION

REVISION HISTORY		
Page	Date	Added/Updated/New
		None



# 1. PRODUCT INFORMATION

## 1.1 PRODUCT OVERVIEW

### 1.1.1 COMPONENT LAYOUT

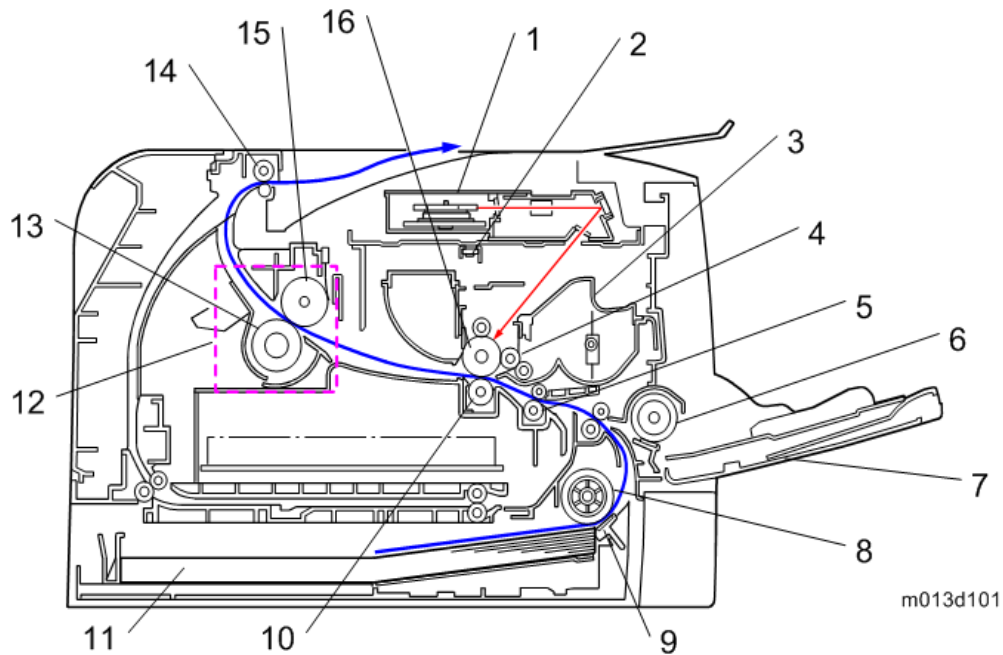

1.	Laser unit	9.	Friction pad
2.	Quenching lamp	10.	Transfer roller
3.	Cartridge (AIO-type)	11.	Paper Tray
4.	Development roller	12.	Fusing Unit
5.	Registration roller	13.	Pressure Roller
6.	By-pass feed roller	14.	Paper exit roller
7.	By-pass feed tray	15.	Hot Roller
8.	Paper feed roller	16.	Drum

### 1.1.2 PAPER PATH

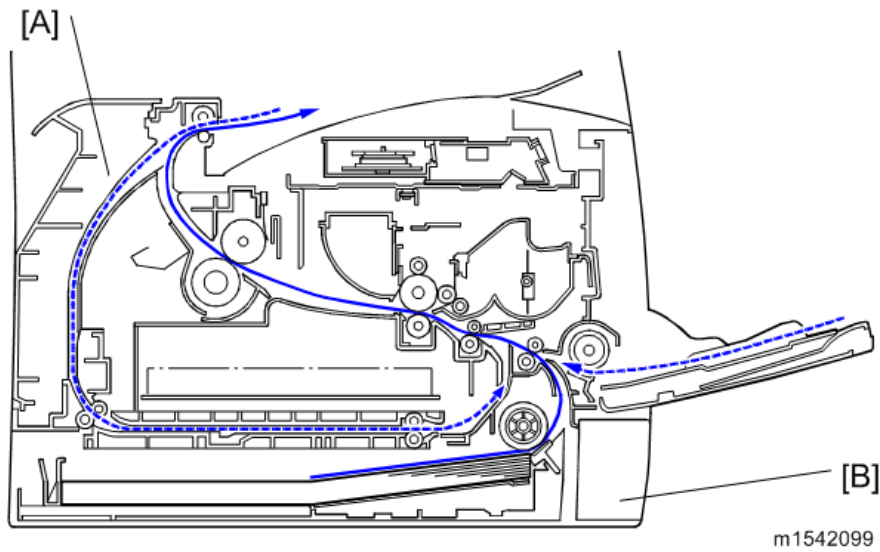

[A] Duplex section

[B] Standard paper tray unit

### 1.1.3 DRIVE LAYOUT

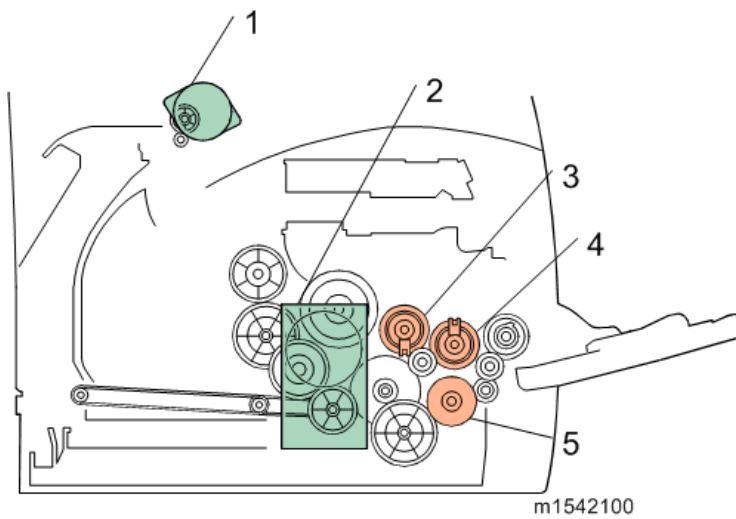

1.	Duplex Motor	4.	Relay Clutch
2.	Main Motor	5.	Paper Feed Clutch
3.	Registration Clutch		

## 1.2 MACHINE CODES AND PERIPHERALS CONFIGURATION

### 1.2.1 MAIN FRAME

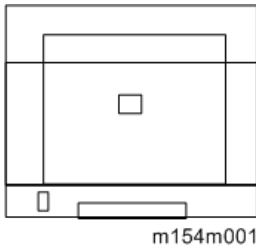

Item	Machine Code	Duplex	Optional Tray	PCL	PS	Wireless LAN	Remarks
SP 310DN	M174	Auto	N/A	Yes	N/A	N/A	NEW
SP 310DNw	M175	Auto	N/A	Yes	N/A	Yes	NEW
SP 311DN	M154	Auto	N/A	Yes	N/A	N/A	NEW
SP 311DNw	M155	Auto	N/A	Yes	N/A	Yes	NEW
SP 320DN	M0A7	Auto	N/A	Yes	N/A	N/A	NEW
SP 325DN	M287	Auto	N/A	Yes	N/A	N/A	NEW
SP 377DNwX	M0BB	Auto	N/A	Yes	N/A	Yes	NEW

NA: Not Available



# INSTALLATION

REVISION HISTORY		
Page	Date	Added/Updated/New
		None



## 2. INSTALLATION

### 2.1 INSTALLATION REQUIREMENTS

#### 2.1.1 CHECK IMAGE QUALITY / SETTINGS

This machine is installed by the user.

##### *Environment*

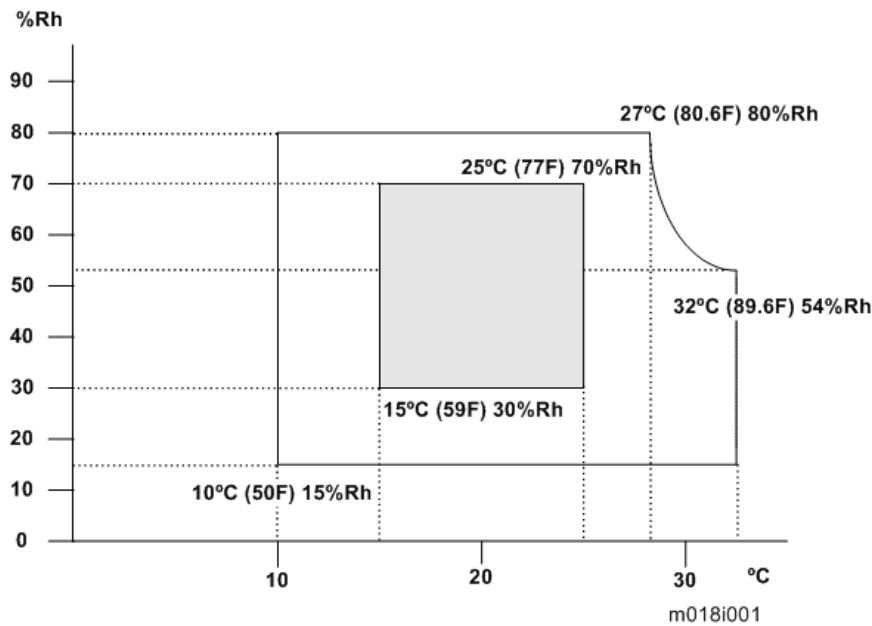

1. Temperature Range: 10°C to 32°C (50°F to 89.6°F)
2. Humidity Range: 15% to 80% RH
3. Ambient Illumination: Less than 2,000 lux (do not expose to direct sunlight)
4. Ventilation: 3 times/hr/person
5. Do not install the machine at locations over the following heights above sea level.
  - All areas: 2,000 m (6,562 ft.)
6. Atmospheric pressure: more than 740 hPa.

## 2.1.2 MOVING AND TRANSPORTING THE MACHINE

### **WARNING**

- It is dangerous to handle the power cord plug with wet hands. Doing so could result in electric shock.

### **CAUTION**

- Unplug the power cord from the wall outlet before you move the machine. While moving the machine, take care that the power cord is not damaged under the machine. Failing to take these precautions could result in fire or electric shock.

### **CAUTION**

- When disconnecting the power cord from the wall outlet, always pull the plug, not the cord. Pulling the cord can damage the power cord. Use of damaged power cords could result in fire or electric shock.

### **CAUTION**

- The printer weighs approximately 12.7 kg (28 lb.). When moving the printer, use the inset grips on both sides, and lift slowly in pairs. The printer will break or cause injury if dropped.

### **CAUTION**

- When moving the printer after use, do not take out any of the toners, nor the waste toner bottle to prevent toner spill inside the printer.

### **CAUTION**

- Do not hold the control panel while moving the printer. Doing so may damage the control panel, cause a malfunction, or result in injury.

### **Important**

- Be careful when moving the printer. Take the following precautions:
- Turn off the main power.
- Close all covers and trays, including the front cover and bypass tray.
- If optional paper feed units are attached, remove them from the printer and move them separately.
- Be sure to place the printer on a smooth and stable place.
- Keep the printer level and carry it carefully, taking care not to jolt or tip it. Rough handling may cause a malfunction or damage the hard disk or memory, resulting in loss of stored files.
- Protect the printer from strong shocks. Impact can damage the hard disk and cause stored files to be lost. As a precautionary measure, files should be copied to another computer.

1. Be sure to check the following:
  - The power switch is turned off.
  - The power cord is unplugged from the wall outlet.
  - The interface cable is unplugged from the printer.
2. **Lift the printer by using the inset grips on both sides of the printer, and then move it horizontally to the place where you want to install it.**

 Note

- Be sure to move the printer horizontally. To prevent toner from scattering, move the printer slowly.



# PREVENTIVE MAINTENANCE

REVISION HISTORY		
Page	Date	Added/Updated/New
		None



---

## 3. PREVENTIVE MAINTENANCE

### 3.1 PREVENTIVE MAINTENANCE TABLES

There are no PM parts in this machine.

### 3.2 IMAGE QUALITY STANDARDS

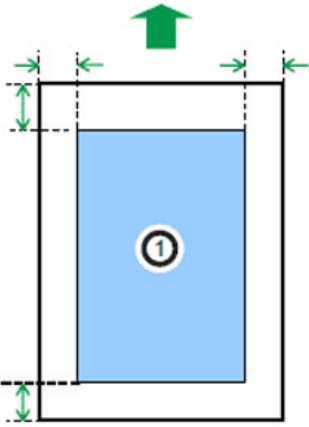
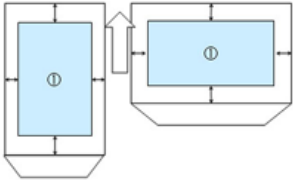
Item	Specification	Remarks
Assured Image Area	<p><b>Except Envelopes</b> The standard print area of a sheet is the area enclosed by margins of 4.2 mm from all sides of the sheet.</p> <p><b>Envelopes</b> The 15mm excluding the flap portion from the rear end / tip of the sheet, except for the region of the left and right ends 10mm.</p>	<p><b>Except Envelopes</b></p>  <p><b>Envelopes</b></p> 
Magnification Error	±0.75% or less	Except when duplexing.

### 3.3 PAPER TRANSFER QUALITY STANDARDS

Item	Specification	Remarks
Registration	<p><b>Single Side:</b>                      Width: 0±2.0mm (Main Scan Direction)                      Vertical: Office / All Environments 0±1.5mm (Sub Scan Direction)</p> <p><b>Duplex:</b>                      Width: 0±2.0mm (Main Scan Direction)                      Vertical: Office / All Environments 0±1.5mm (Sub Scan Direction)</p>	Scale
Skew	<p><b>Single Side:</b>                      ±1.0mm/100mm or less (Less than B5 SEF)                      ±1.0mm/200mm or less (B5 SEF or more, tray 1 /Bypass tray)                      ±1.0mm/50mm or less (Bypass tray)</p> <p><b>Duplex:</b>                      ±1.0mm/100mm or less (Less than B5 SEF)                      ±1.0mm/100mm or less (B5 SEF or more)</p>	Except if the paper is longer than 432mm.

Preventive Maintenance

These standards are determined using the standard paper with the standard conditions. The values may change depending on environmental conditions such as temperature, humidity, and paper type.

## 3.4 PM PARTS SETTINGS

### 3.4.1 PM PARTS

There are no PM parts in this machine.



- Other than the three Yield Parts listed below, there are essentially no PM parts required for this product.
- These three items will need to be replaced in cases where their yield is near, however, given the APV (Average Printer Volume) for this product, these "yield parts\*1 " are expected to outlast the working life of the machine.

\*1 "**Yield Parts**": Parts whose expected yield is longer than the machine lifetime when taking into consideration the machine's APV.

Description	Expected Yield	Q'ty/unit
Paper Feed Roller	120 K prints	1
Transfer Roller	120 K prints	1
Fusing Unit	120 K prints	1

See "page 4-1 "Replacement and Adjustment""

## 3.5 PREPARATION FOR PM

### 3.5.1 YIELD COUNTER

Yield counters for each yield part can be checked by the following methods.

- **Configuration Page in the “List/Test Print” menu**

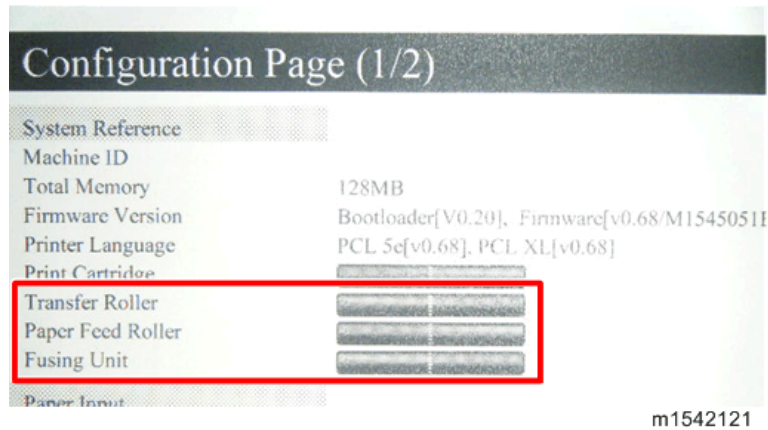

- **Smart Organizing Monitor**

Click "Maintenance" in the "Status" tab.

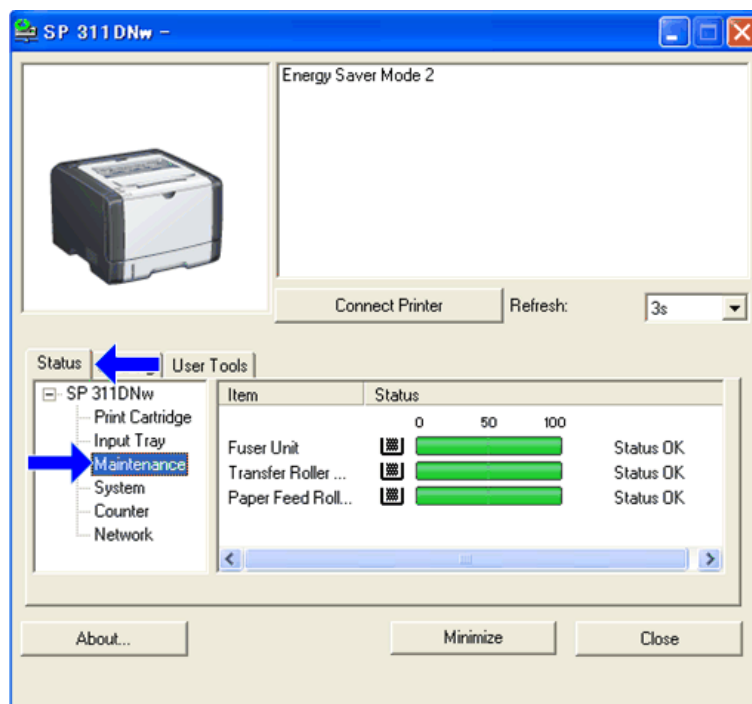

## Preparation for PM

### Web Image Monitor

The screenshot shows the Ricoh SP 310DN Web Image Monitor interface. The 'Status' tab is selected, displaying a table of component levels and status. A red box highlights the 'Status' section.

Component	Level	Status
Print Cartridge	Remaining Level 5	
Fusing Unit	Status OK	
Transfer Roller	Status OK	
Paper Feed Roller	Status OK	

Other visible information includes: Model Name: SP 310DN, Location: , Contact: , Host Name: 310DN-S2CA40, Status: Energy Saver 2. Paper Tray status: Tray 1: Out of Paper, A4, Plain Paper; Bypass Tray: Out of Paper, A4, Plain Paper.

m1542107

#### Note

- The machine displays "Fuser life end notice", "Transfer roller life end notice" or "Life End of Paper Feed Roller Unit" when one of these counters reaches its yield.

### Counter Reset

The process below shows how to reset the yield counters.

1. Start the SOM utility.
2. Click the "User Tools" tab.
3. Click "Printer Configuration".

The screenshot shows the SP 311DNw SOM utility interface. The 'User Tools' tab is selected, and the 'Printer Configuration' button is highlighted with a blue arrow.

Visible elements include: Energy Saver Mode 2, Connect Printer, Refresh: 3s, Status | Job Log | User Tools, List/Test Print, Configuration Page, Print, Printer Configuration, IP Address, About..., Minimize, Close.

m1542108

4. The "Access Code" entry dialog appears.
5. Input the access code (for customer engineers).and then Click "OK".

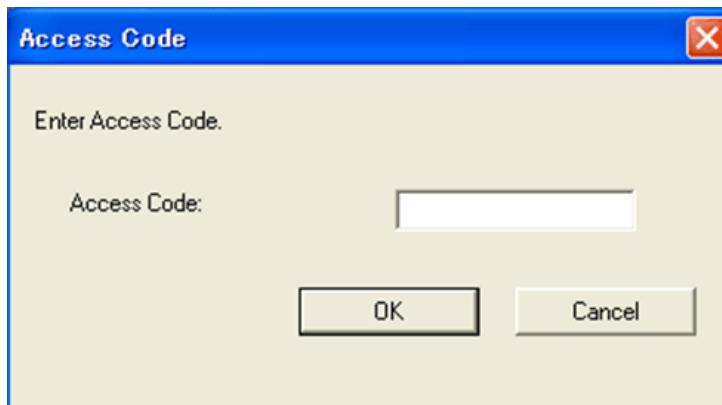

m1542111

6. Click the "SP Mode 3" tab.
7. Click "Clear Transfer Roller EM Counter", "Clear Paper Feed Roller EM Counter" or "Clear Fusing Unit EM Counter" and click "OK".

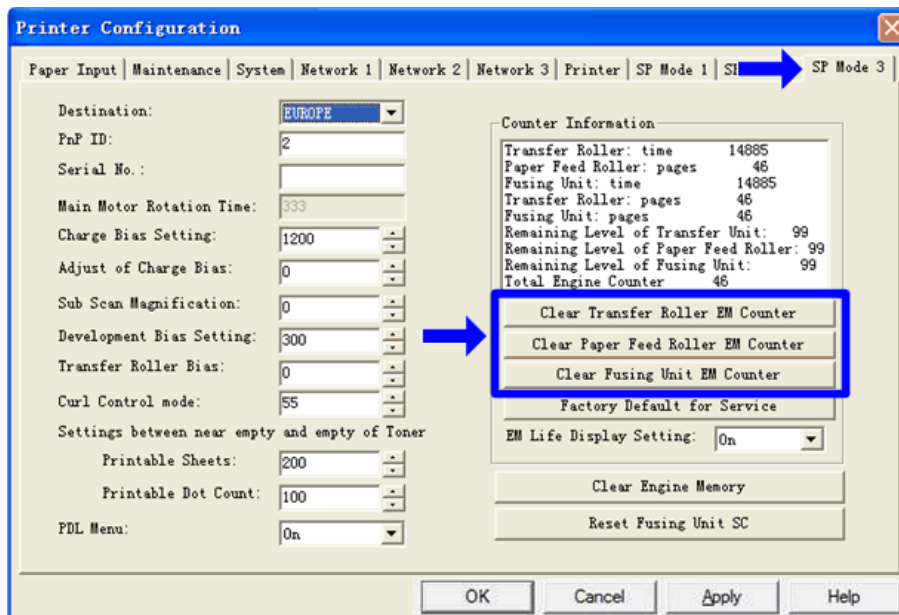

m1542114

8. Exit the SOM utility.



# REPLACEMENT AND ADJUSTMENT

REVISION HISTORY		
Page	Date	Added/Updated/New
41 ~ 42	06/07/2018	Added Before installing new main board



---

## 4. REPLACEMENT AND ADJUSTMENT

### 4.1 GENERAL CAUTIONS

#### CAUTION

- If there are printer jobs in the machine, print out all jobs in the printer buffer.
- Turn off the main power switch and unplug the machine before you do the procedures in this section.

## 4.2 SPECIAL TOOLS

- PC: Windows XP/Vista/7/8, Windows Server 2003/2003 R2, 2008/2008 R2,2012
- USB or network cable



- A computer is necessary to update the firmware.

## 4.3 EXTERIOR COVERS

### 4.3.1 FRONT COVER

1. Pull out the standard paper tray [A].



m1542001

2. Two tabs [A]



m1542002

3. On the right side, push down the tab, and then slide the bypass tray [A] to the right.
4. Pull out the bypass tray [A].

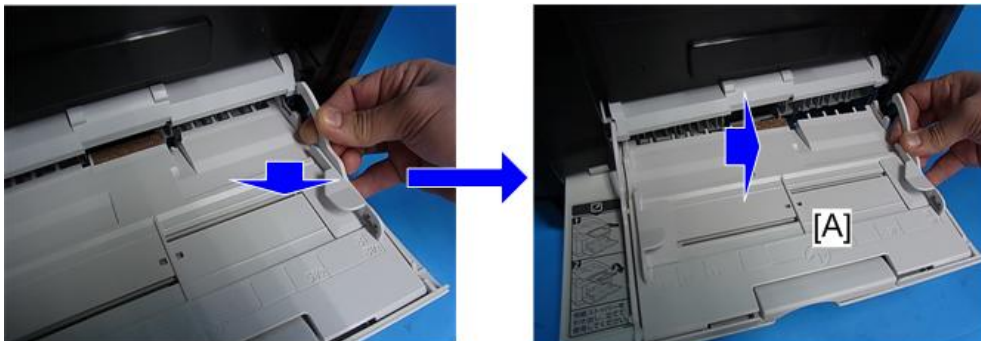

m1542003

## Exterior Covers

5. Open the front cover [A].



m1542004

### ↓ Note

- To open the front cover, push the cover release button [B] and (carefully) pull the cover forward and open (it hinges downward).

6. Push the right hinge [A] to release.

7. Front cover [B]

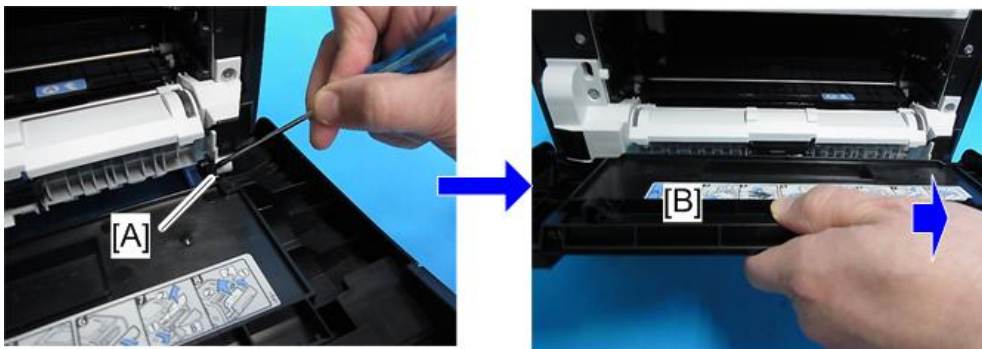

m1542005

### 4.3.2 LEFT COVER

1. Front cover (page 4-3 "Front Cover")
2. Rear cover (page 4-7 "Rear Cover")
3. Remove two screws [A] on the front side of the left cover.

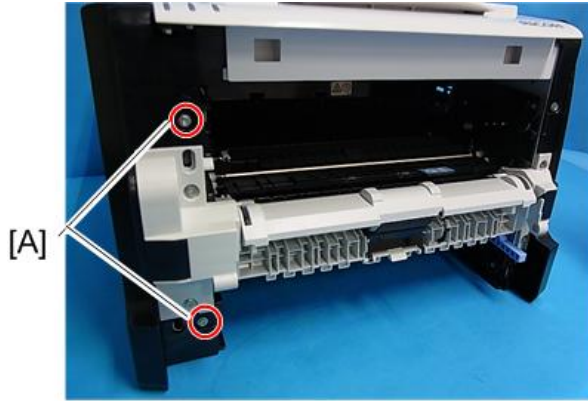

m1542006

4. Remove a screw [A] on the rear upper side of the left cover.

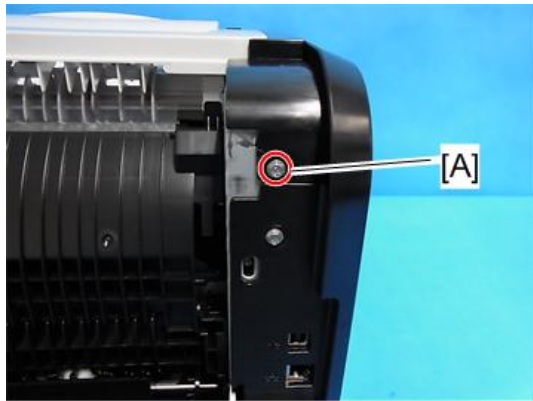

m1542007

5. Pull the rear upper part [A] of the left cover to release the hooks.



m1542008

↓ Note

- The outside of the cover has marks indicating the position of the hooks.

6. Pull the front upper part [A] of the left cover to release the hooks.

## Exterior Covers

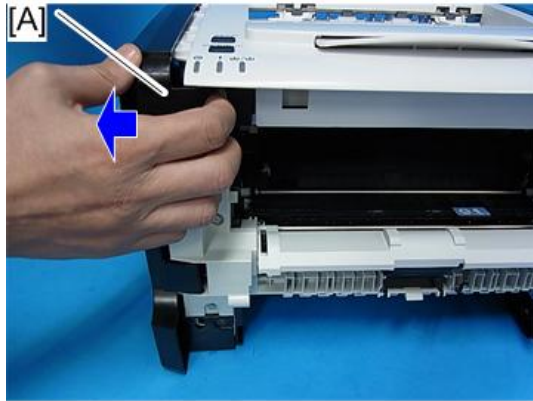

m1542009

### ↓ Note

- The outside of the cover has marks indicating the position of the hooks.

7. Pull the front bottom part of the left cover [A] to release the hooks.

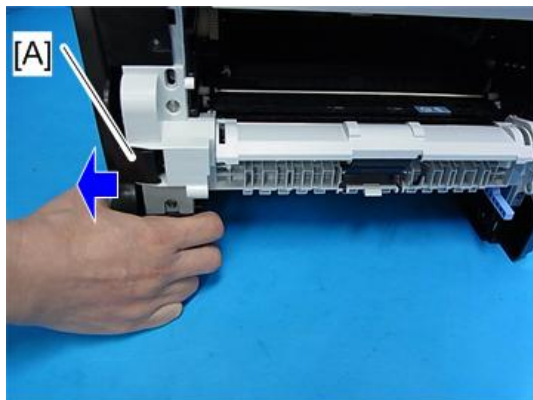

m1542010

### ↓ Note

- The outside of the cover has marks indicating the position of the hooks.

8. Left cover [A]

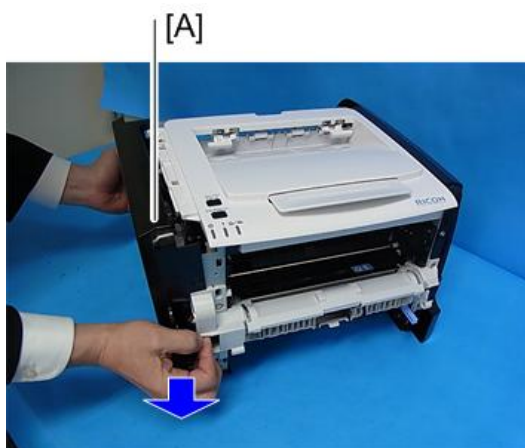

m1542011

### ↓ Note

- There are many hooks and tabs inside the left cover. Before removing the left cover, see the photos below.

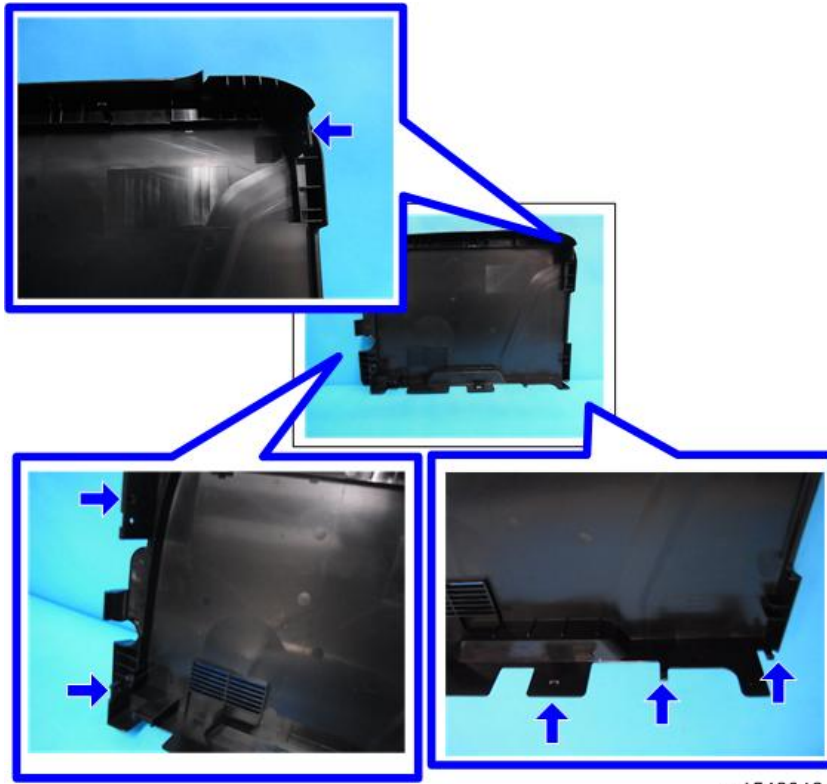

m1542012

### 4.3.3 REAR COVER

1. Open the rear cover [A]
2. Slide the shaft [B] in the direction of the blue arrow, and remove the rear cover [A].

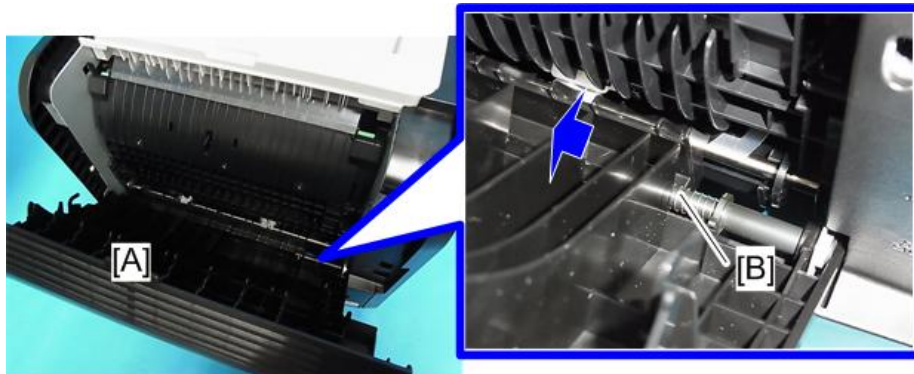

m1542013

### 4.3.4 RIGHT COVER

1. Front cover (page 4-3 "Front Cover")
2. Rear cover (page 4-7 "Rear Cover")
3. Right cover [A] (🔧 x 3, hook at arrow mark)

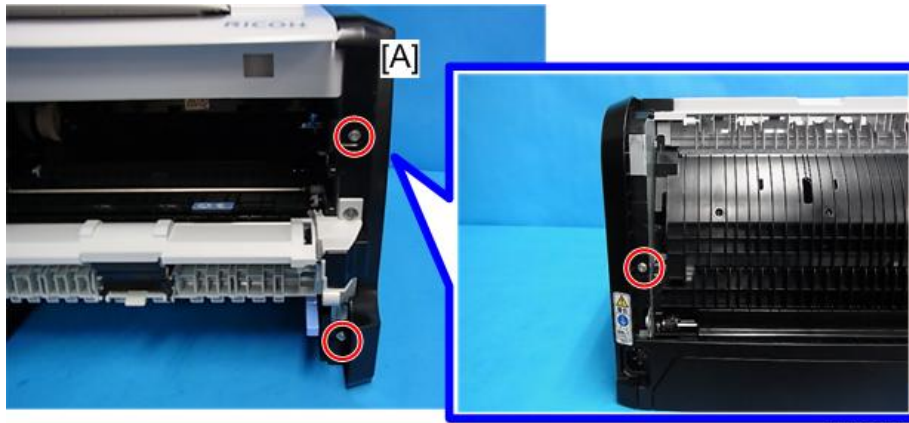

m1542014

↓ Note

- The outside of the cover has marks indicating the position of the hooks.

↓ Note

- There are many hooks and tabs inside the right cover. Before removing the right cover, see the photos below.

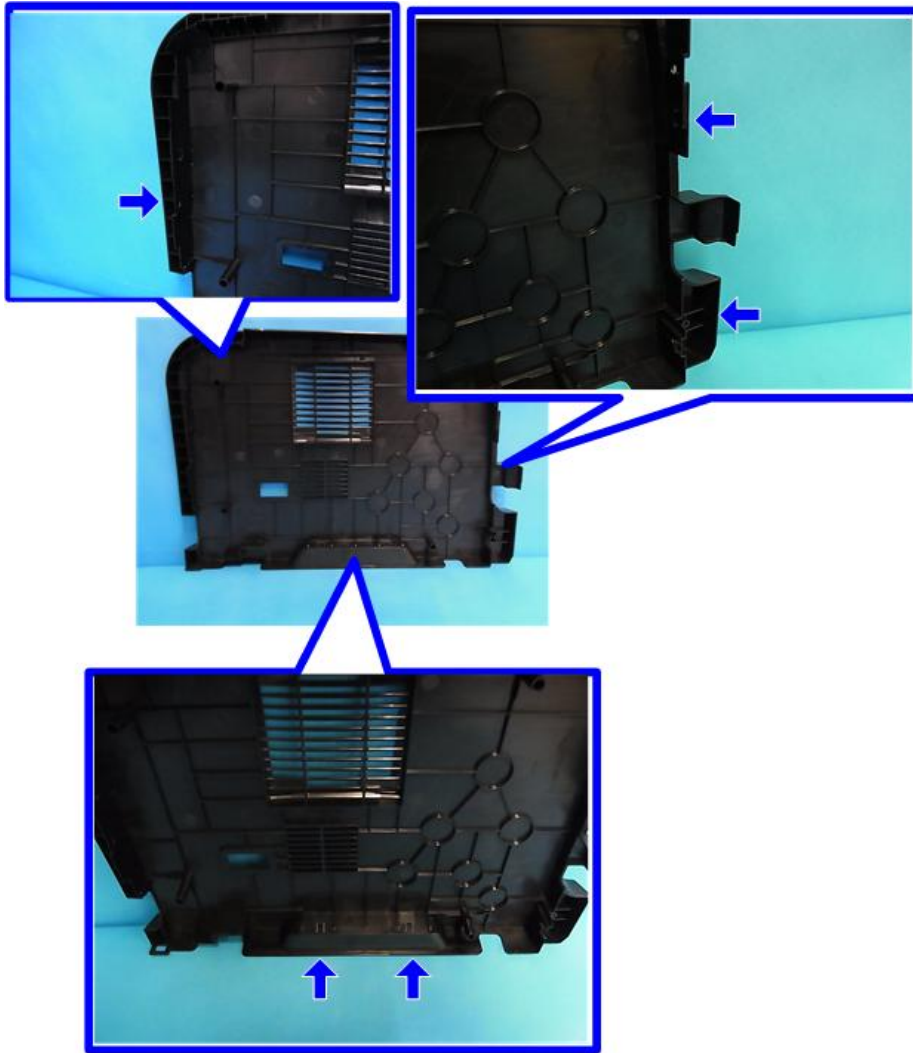

Replacement  
and Adjustment

m1542015

### 4.3.5 TOP COVER

1. Front cover (page 4-3 "Front Cover")
2. Rear cover (page 4-7 "Rear Cover")
3. Left cover (page 4-5 "Left Cover")
4. Right cover (page 4-8 "Right Cover")
5. Top cover [A] (🔧 x 4, 🛠️ x 1, 📏 x 1) (For M155,M175: 🔧 x 4, 🛠️ x 2, 📏 x 1)

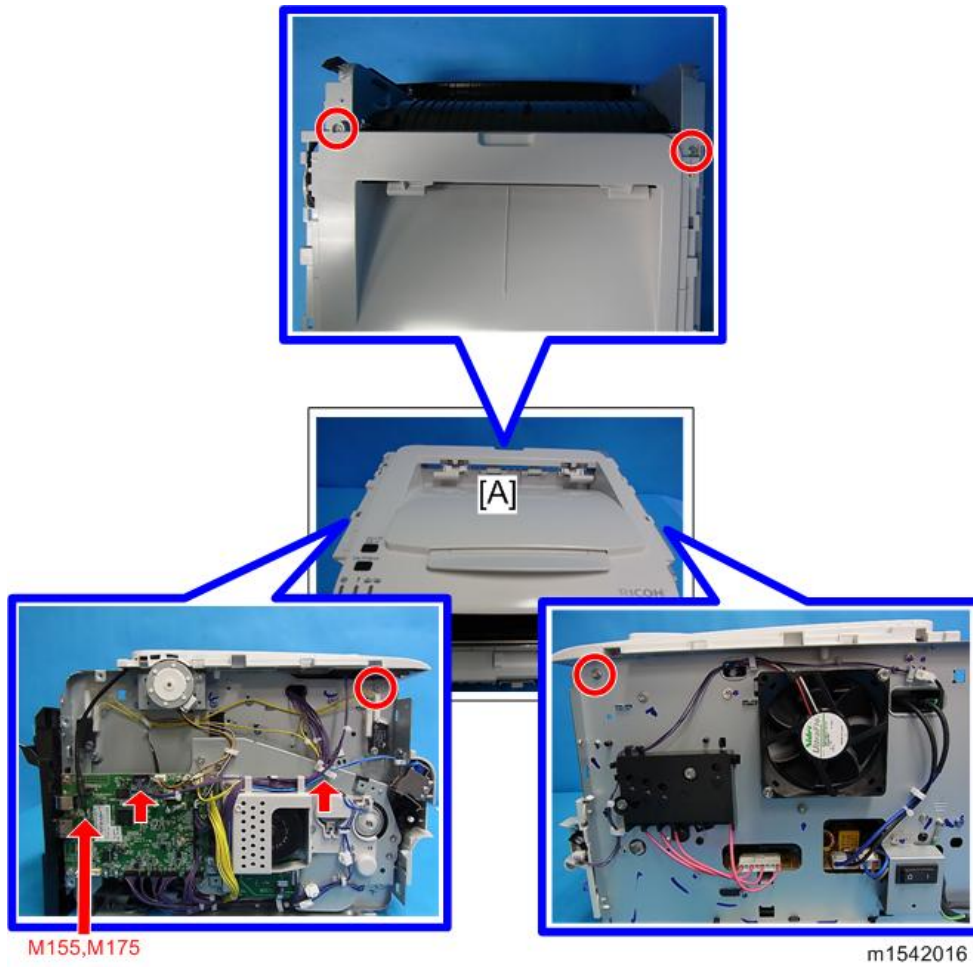

***When installing the top cover***

- When re-installing the top cover, always verify that the two paperweights [A] are lifted. If they are not lifted to fit into the paper slot, the paperweights [A] could be damaged.
- Make sure that these paperweights [A] can be moved smoothly (up and down) after installing the top cover. If these paperweights do not move smoothly, try installing the top cover again.

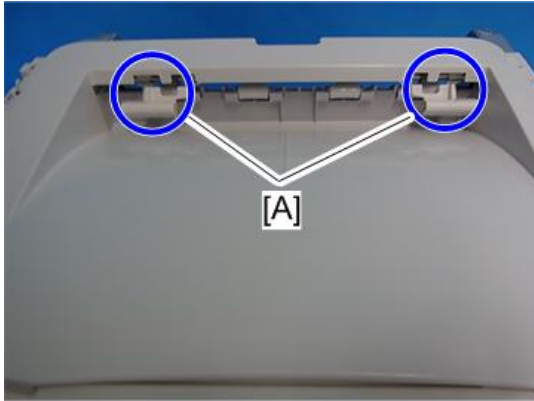

m1542017

## 4.4 LASER UNIT

### CAUTION

- Turn off the main power switch and unplug the machine before attempting any of the procedures in this section. Laser beams can seriously damage your eyes.

#### 4.4.1 CAUTION DECAL LOCATIONS

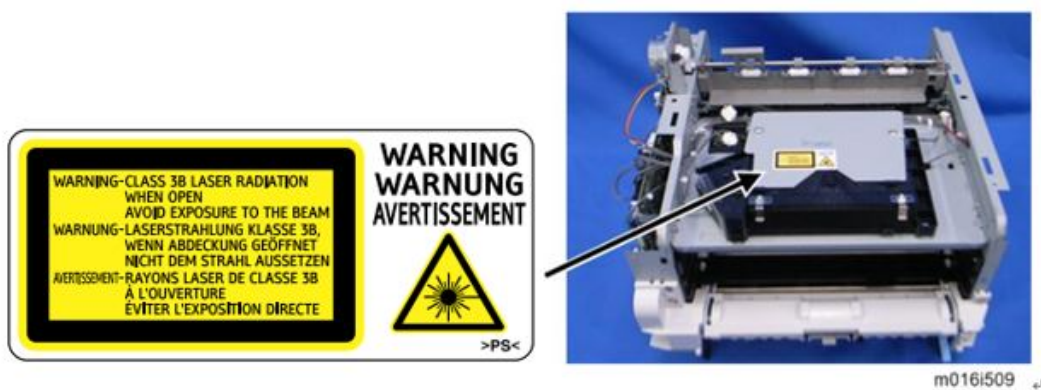

A caution decal is attached as shown below.



### WARNING

- Be sure to turn off the main switch and disconnect the power plug from the power outlet before beginning any disassembly or adjustment of the laser unit. This machine uses a class IIIB laser beam with a wavelength of 648 to 663 nm and an output of 9 mW. The laser can cause serious eye injury.

## 4.4.2 LASER UNIT

1. Front cover (page 4-3 "Front Cover")
2. Rear cover (page 4-7 "Rear Cover")
3. Left cover (page 4-5 "Left Cover")
4. Right cover (page 4-8 "Right Cover")
5. Top cover (page 4-10 "Top Cover")
6. Laser unit [A] (  x 3, ground screw x 3,  x 2,  x 1)

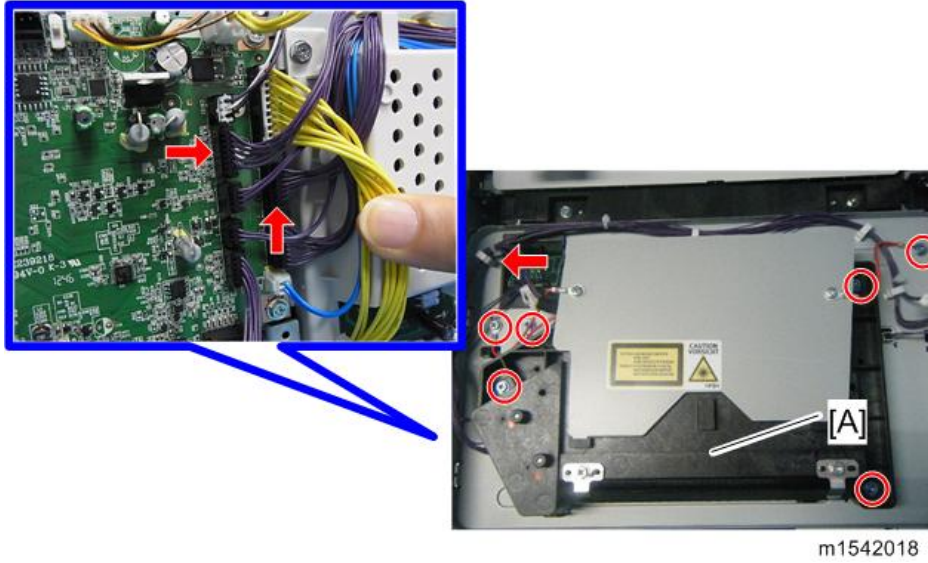

Replacement and Adjustment

### 4.4.3 POLYGON MIRROR MOTOR

#### **⚠ CAUTION**

- Turn off the main switch and unplug the machine before attempting any of the procedures in this section. Laser beams can seriously damage your eyes.

1. Top cover (page 4-10 "Top Cover")
2. Polygon mirror cover [A] (🔩 x 2)

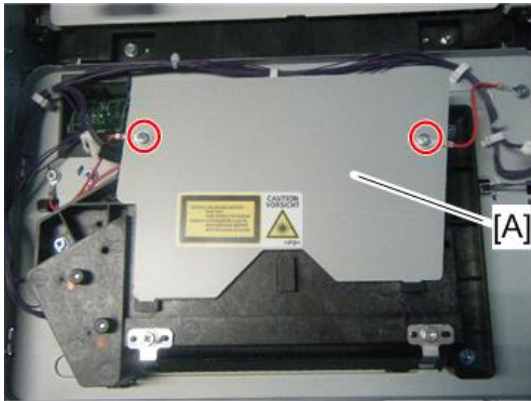

m1542020

3. Polygon mirror motor [A] (🔩 x 4, 📏 x 1)

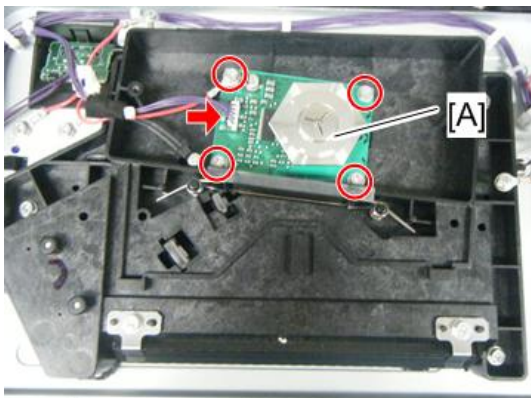

m1542021

#### **↓ Note**

- Never touch the surface of the mirror with bare hands.

## 4.5 PAPER FEED

### 4.5.1 PAPER FEED ROLLER

1. Pull out the standard paper tray.
2. Front cover (page 4-3 "Front Cover")
3. AIO
4. Set the machine with the rear side facing down, resting on the table.

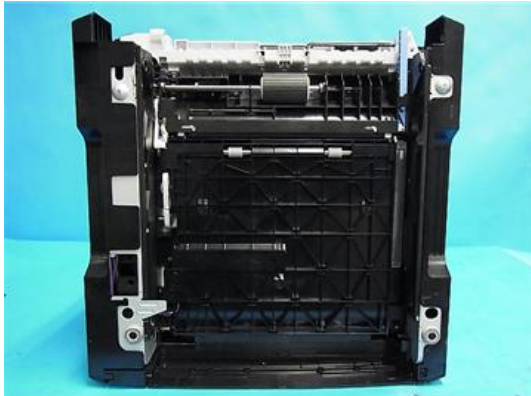

m1542022

5. Slide the paper feed shaft [A] to the left side (⏪ x 2).
6. Slide the paper feed roller [B] to the right side, and remove it (hook).

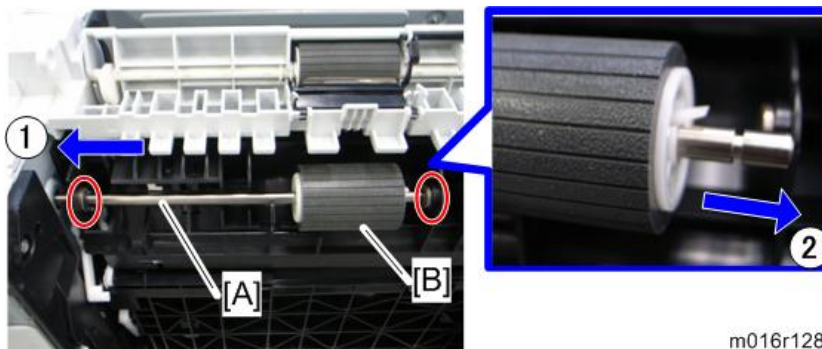

m016r128

#### ***After installing a new paper feed roller***

1. Enter the "Printer Configuration" in the SOM.
2. Select the "SP Mode 3" tab.
3. Click "Clear Paper Feed Roller EM Counter" and then click "OK".
4. Exit the SOM.

## 4.5.2 FRICTION PAD

1. Remove the paper tray unit from the machine before removing the friction pad.
2. Friction pad [A] (2 hooks, spring)

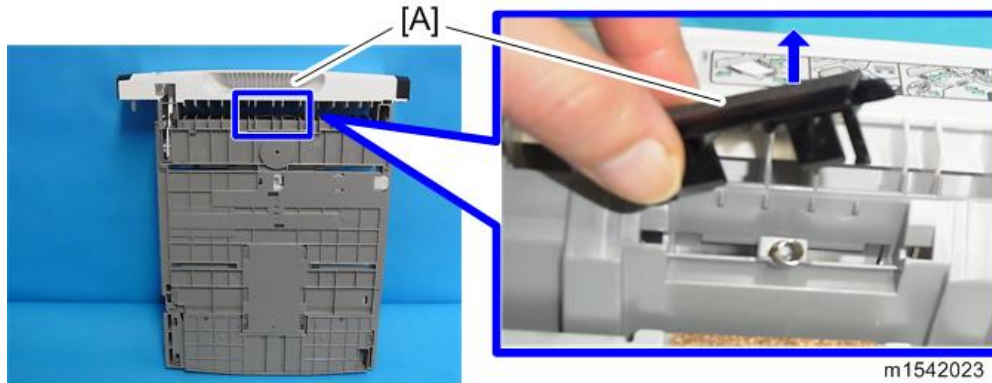

***When reinstalling the friction pad, do it in this order:***

1. Replace the spring.
2. Insert the right side of the friction pad first, followed by the left side.
3. Gently push the friction pad down into the slot and then pull forward very slightly.

## 4.5.3 PAPER END SENSOR

1. Pull out the standard paper tray.
2. Front cover (page 4-3 "Front Cover")
3. AIO
4. Set the machine with the rear side facing down, resting on the table.
5. Paper end sensor [A] (3 hooks,  x 1)



#### 4.5.4 BY-PASS FEED ROLLER

1. Front cover (page 4-3 "Front Cover")
2. Left cover (page 4-5 "Left Cover")
3. Right cover (page 4-8 "Right Cover")
4. Pull out the paper tray.
5. By-pass lower guide plate [A] (🔧 x 4, 📌 x 2, 📌 x 2)

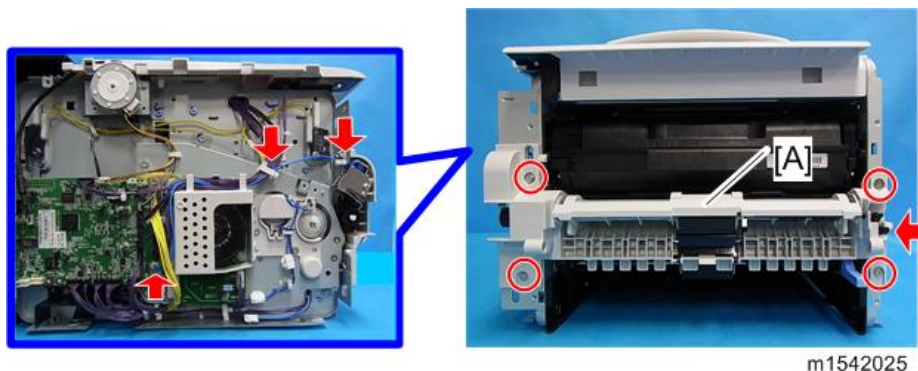

#### ↓ Note

- Reinstall the by-pass lower guide plate [A] while pressing the spring [B].
- Be careful that the spring [B] and the ground plate [C] do not fall inside the machine during reinstallation.

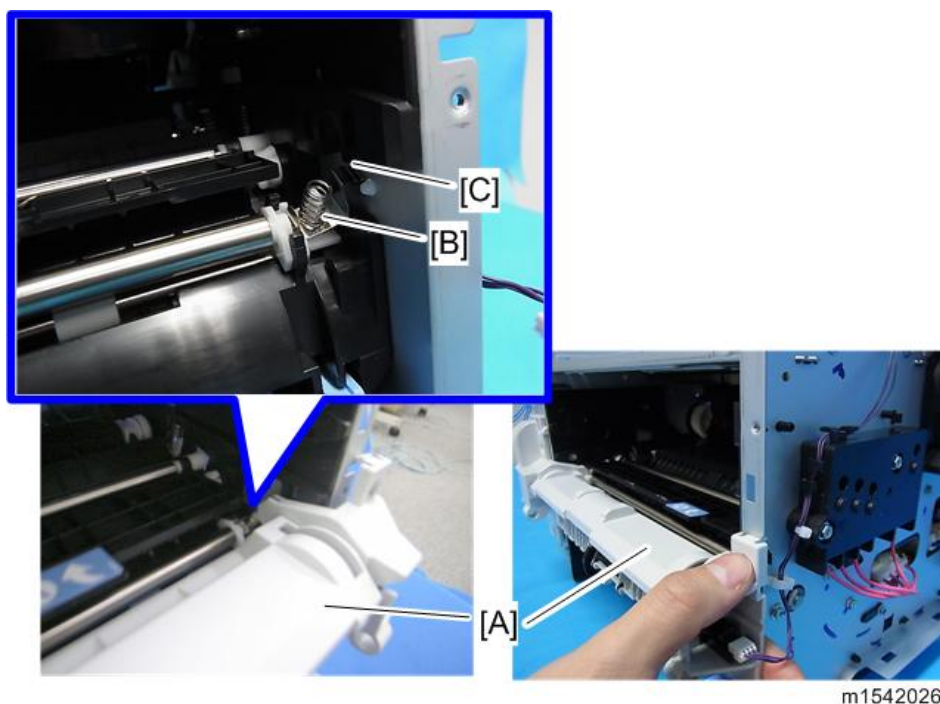

6. By-pass upper guide plate [A]
7. By-pass solenoid cover, by-pass solenoid [B] (🔧 x 1)
8. Gear [C] (hook)

## Paper Feed

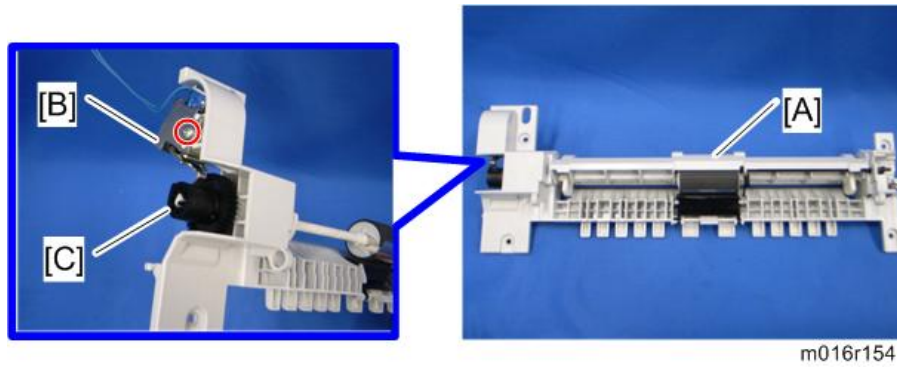

9. Slide the by-pass feed roller shaft [A] to the left side, and remove it.
10. Remove the metal cover [B] from the by-pass feed roller [C].

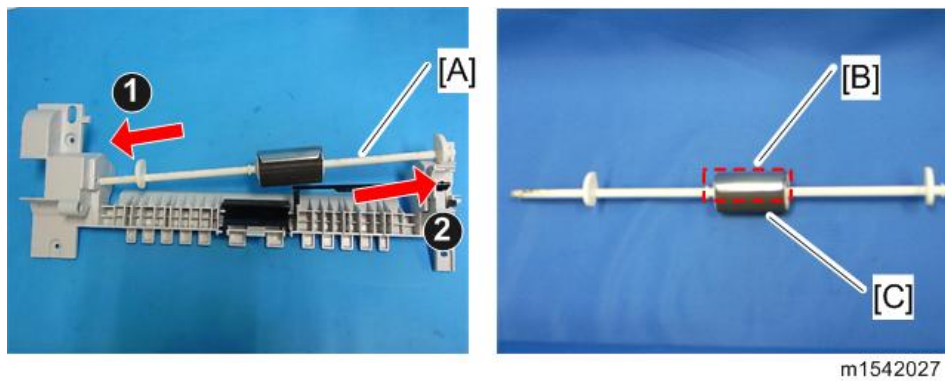

### 4.5.5 BY-PASS FEED ROLLER FRICTION PAD

1. By-pass feed roller (page 4-17 "By-pass Feed Roller")
2. By-pass feed roller friction pad [A] (2 hooks, spring x 1)

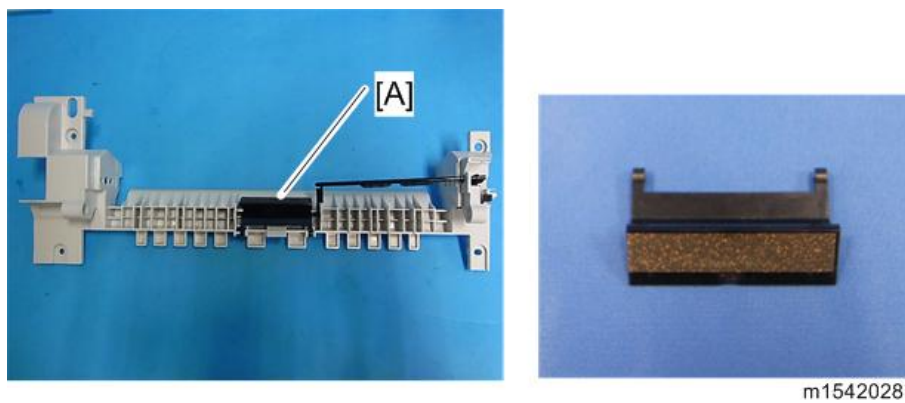

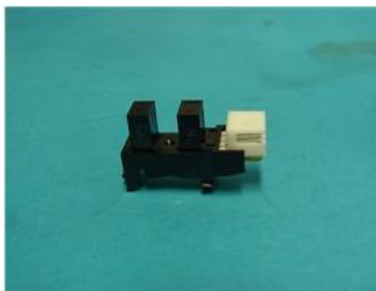
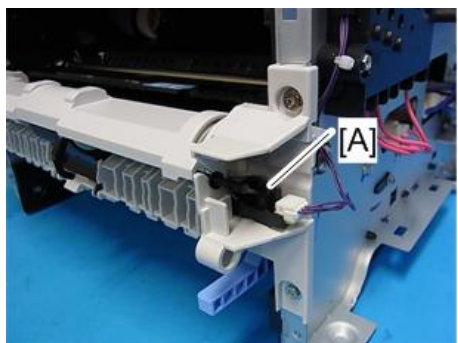

## 4.5.6 BY-PASS FEED SENSOR

1. Front cover (page 4-3 "Front Cover")
2. Right cover (page 4-8 "Right Cover")
3. By-pass feed sensor [A] (3 hooks,  x 1)



m1542029

## 4.5.7 PAPER FEED CLUTCH

1. Drive unit (page 4-37 "Drive Unit")
2. Paper feed clutch [A] ( x 1,  x 1,  x 1)

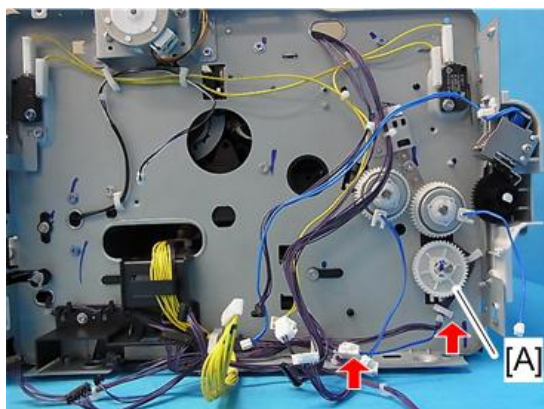

m1542030

## 4.5.8 RELAY CLUTCH

1. Drive unit (page 4-37 "Drive Unit")
2. Relay clutch [A] (Ⓒx 1)

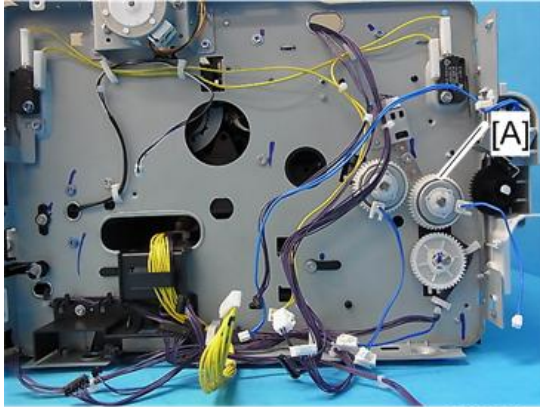

m1542031

## 4.5.9 REGISTRATION CLUTCH

1. Drive unit (page 4-37 "Drive Unit")
2. Registration clutch [A] (Ⓒx 1)

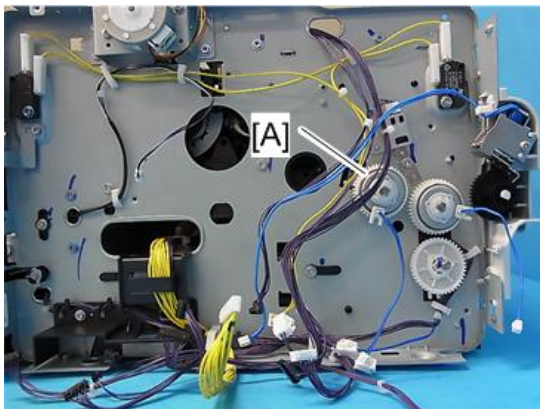

m1542032

## 4.5.10 REGISTRATION ROLLER

1. Pull out the paper tray.
2. AIO
3. Top Cover (page 4-10 "Top Cover")
4. Fusing Unit (page 4-28 "Fusing Unit")
5. PSU / HVP unit (page 4-42 "PSU")
6. By-pass lower guide plate (page 4-17 "By-pass Feed Roller")
7. Paper feed clutch (page 4-19 "Paper Feed Clutch")
8. Relay clutch (page 4-20 "Relay Clutch")
9. Registration clutch (page 4-20 "Registration Clutch")
10. Heat insulating plate [A] (🔩 x 2)

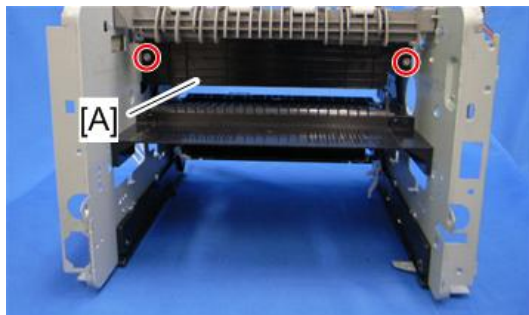

m1542033

11. Duplex motor base [A] (🔩 x 4)

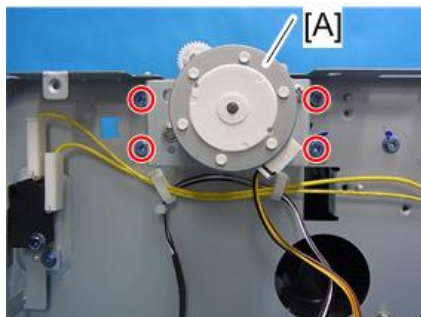

m1542034

12. Exit roller base [A] (🔩 x 2,4 tabs)

Paper Feed

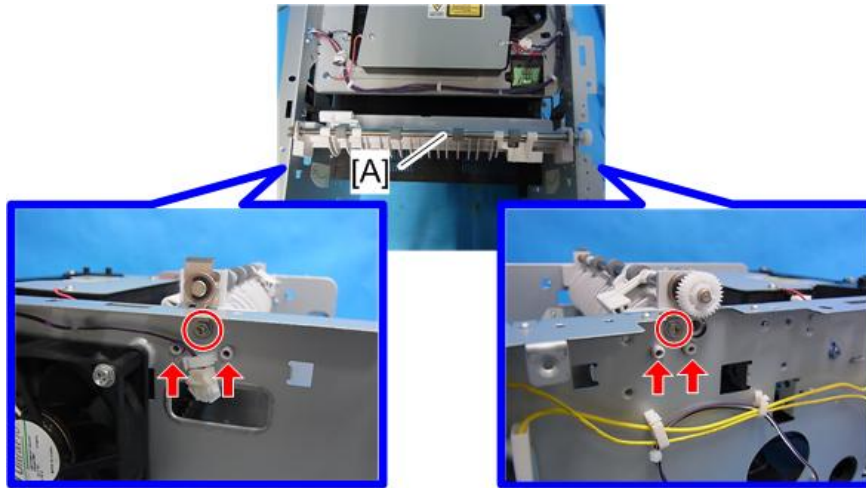

m1542035

13. Imaging unit base [A] (🔩 x 4, 🛠️ x 1, 🛠️ x 4)

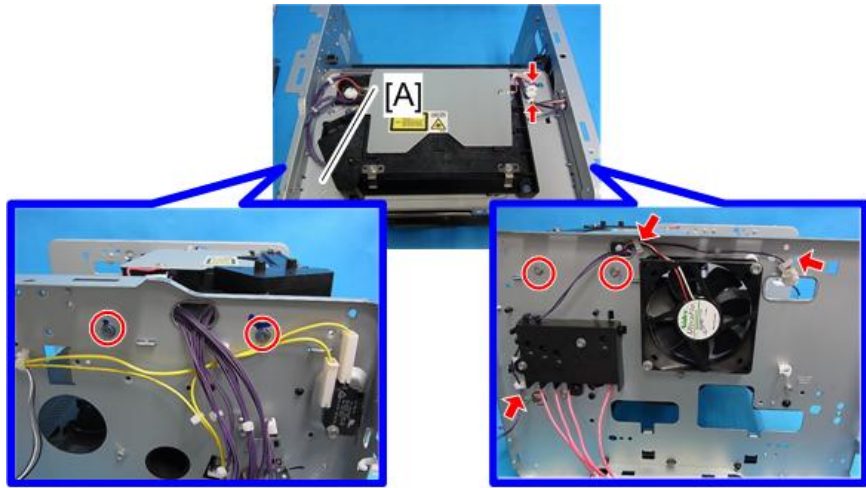

m1542036

14. Registration unit [A] (🔩 x 8, 🛠️ x 3)

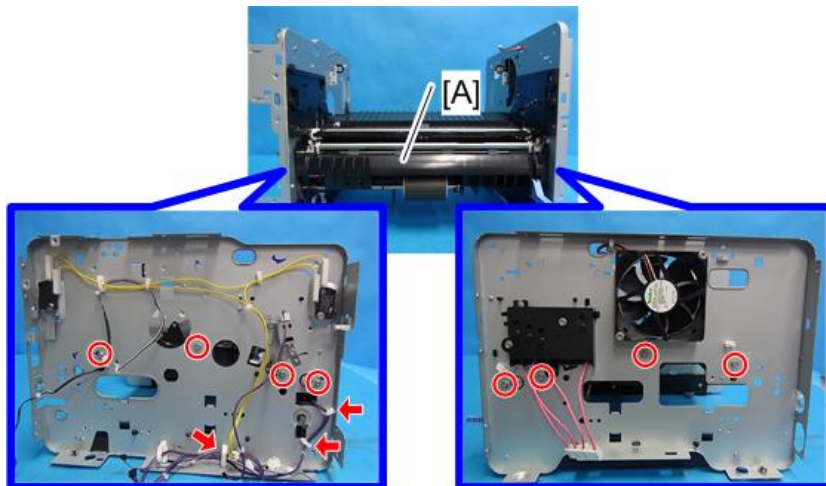

m1542037

15. Upper guide plate [A] (2 hooks)

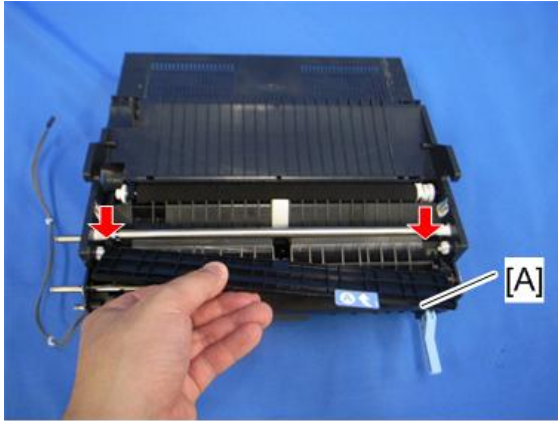

m1542038

16. Remove the registration roller (follower) [A] as shown below (spring x 2, plastic parts x 2).

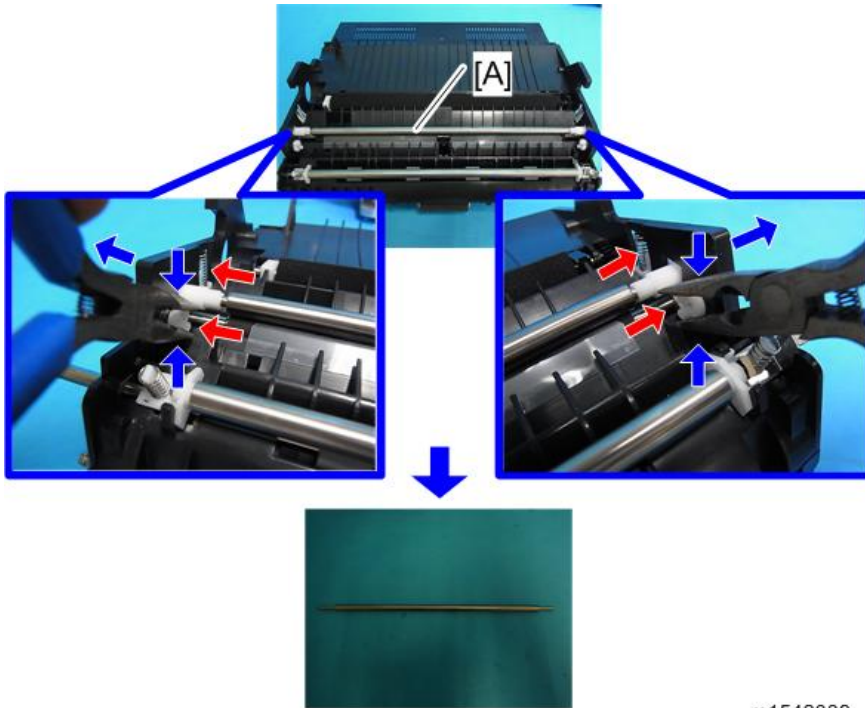

m1542039

Replacement  
and Adjustment

17. Registration roller (drive) [A] (Ⓢ x 2, bushing x 2).

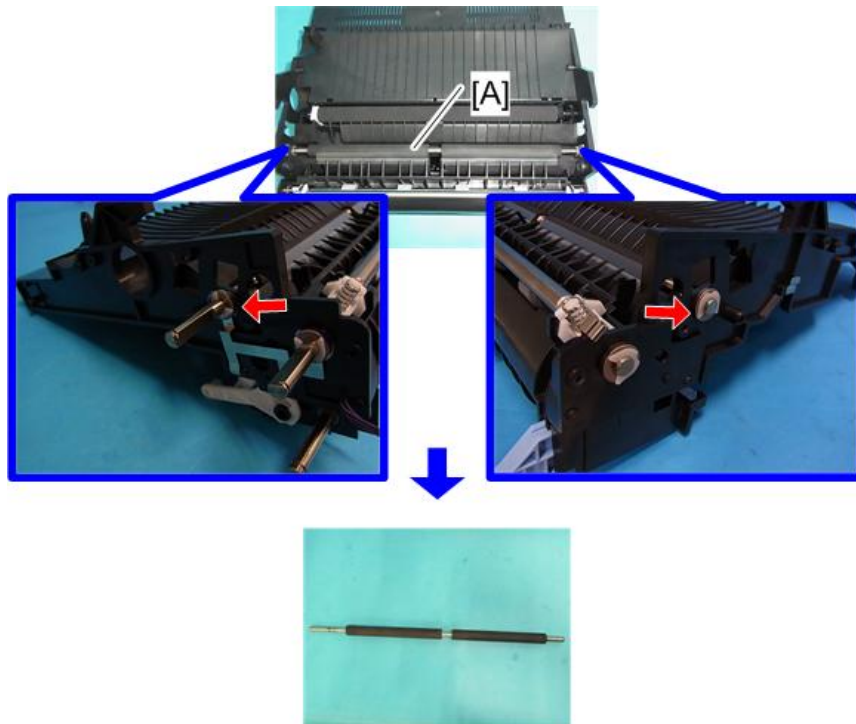

m1542040

#### 4.5.11 REGISTRATION SENSOR

1. Registration unit (page 4-21 "Registration Roller")
2. Turn the registration unit over.
3. Registration sensor [A] (Ⓢ x 1, 3 hooks)

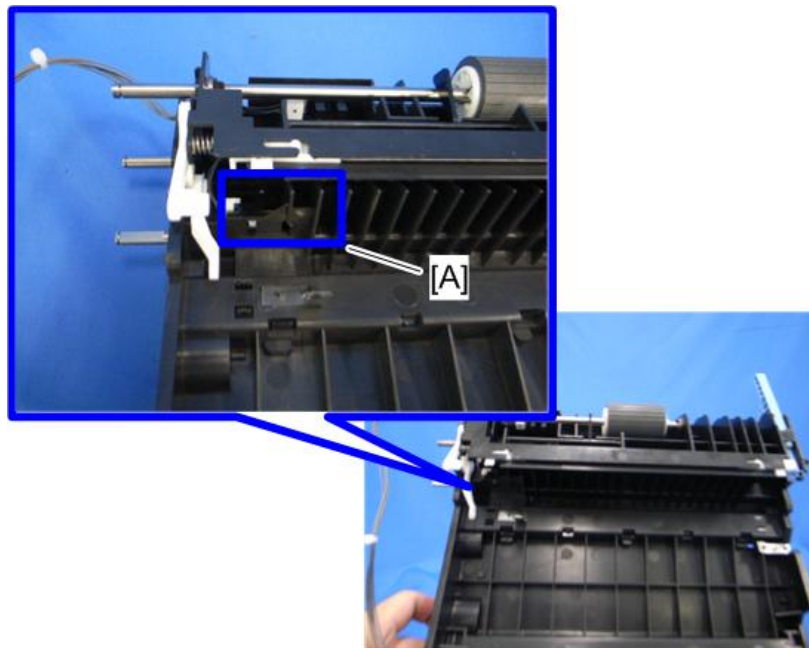

m1542041

## 4.6 IMAGE TRANSFER

### 4.6.1 TRANSFER ROLLER

1. Front cover (page 4-3 "Front Cover")
2. AIO
3. Remove the transfer roller [A] as shown below.

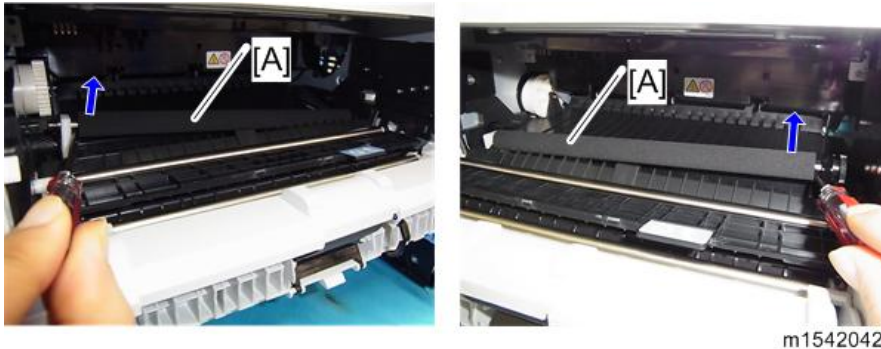

4. Remove the bushing x 2, spring x 2, gear x 1, collar x 1 from the transfer roller.

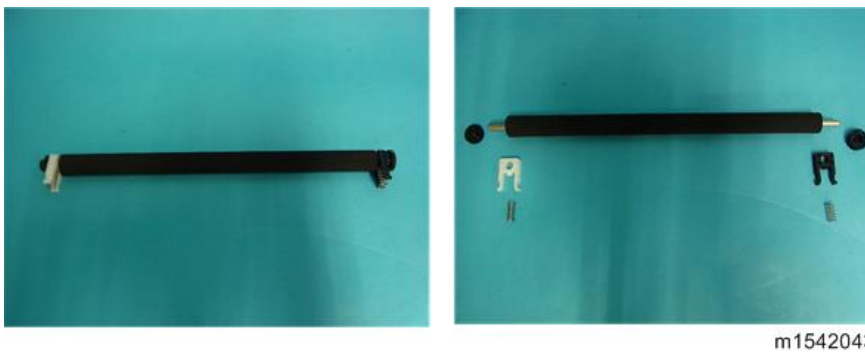

#### ↓ Note

- Do not touch the transfer roller surface when reinstalling the new transfer roller.

#### ***After installing a new transfer roller***

1. Enter the "Printer Configuration" in SOM.
2. Select the "SP Mode 3" tab.
3. Click "Clear Transfer Roller EM Counter" and then click "OK".
4. Exit the SOM.

## 4.6.2 TONER END SENSOR

1. Left cover (page 4-5 "Left Cover")
2. Drive unit (page 4-37 "Drive Unit")
3. Toner end sensor [A] (4 hooks)

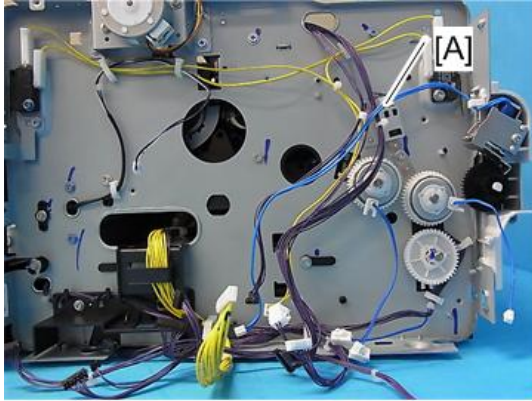

m1542044

### 4.6.3 QUENCHING LAMP

1. Front cover (page 4-3 "Front Cover")
2. Top cover (page 4-10 "Top Cover")
3. AIO
4. Quenching lamp with the case [A] (2 hooks,  x 1).

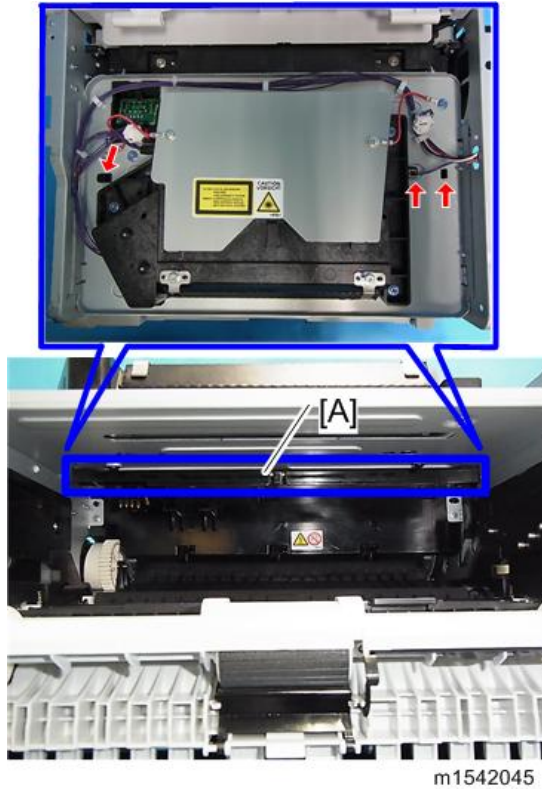

5. Remove the quenching lamp [A] from the case (3hooks).

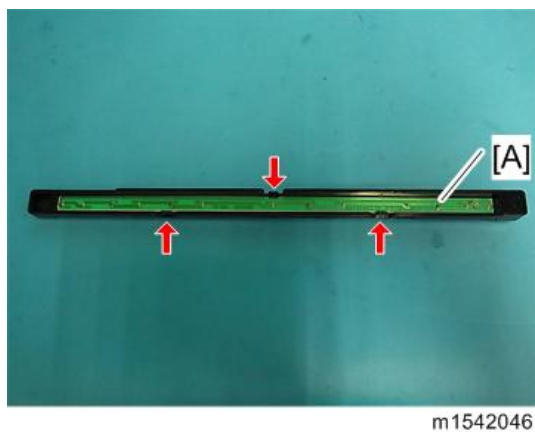

## 4.7 FUSING AND EXIT

### CAUTION

- Switch off the main power, unplug the machine from its power source, and allow the fusing unit to cool before removing it.

#### 4.7.1 FUSING UNIT

1. Right cover (page 4-8 "Right Cover")
2. Rear cover (page 4-7 "Rear Cover")
3. Release the lock [A], and then remove the entrance guide [B] ( x 1)

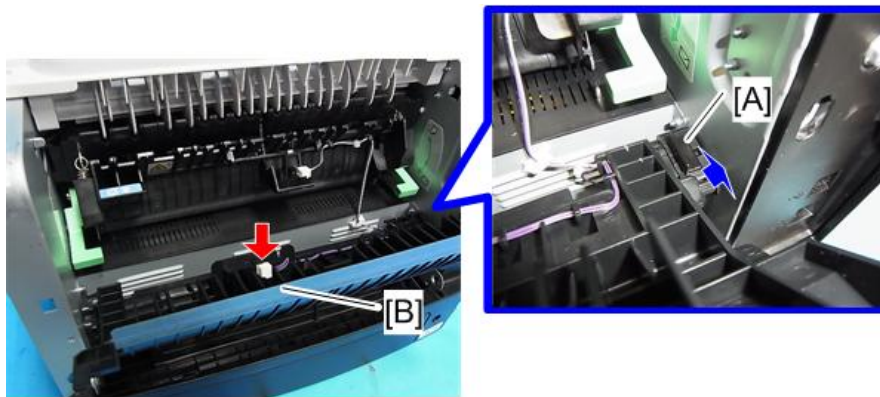

m1542047

4. Disconnect the three connectors ( x 1)

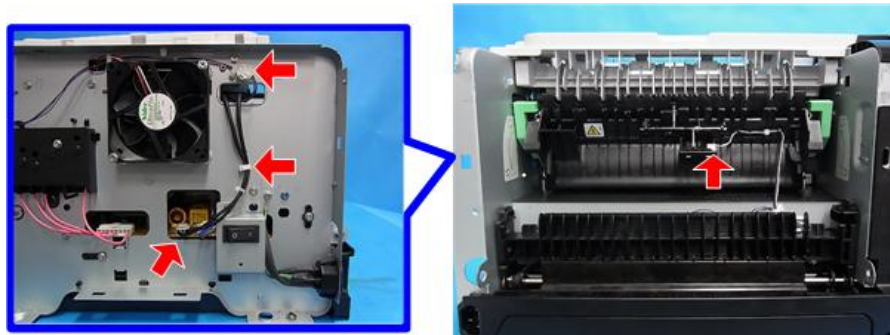

m1542048

5. Pass the cable [A] through the hole [B] inside the machine.

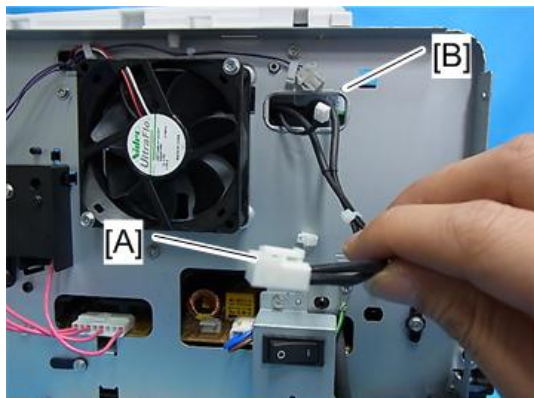

m1542049

6. Fusing unit [A] (⚙ x 4)

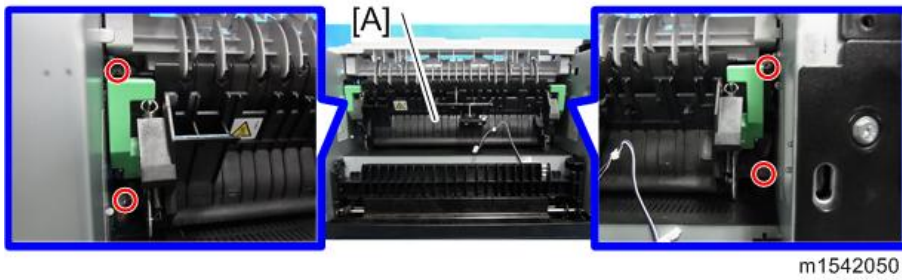

↓ Note

- Make sure that the two bushings [A] remain in position.

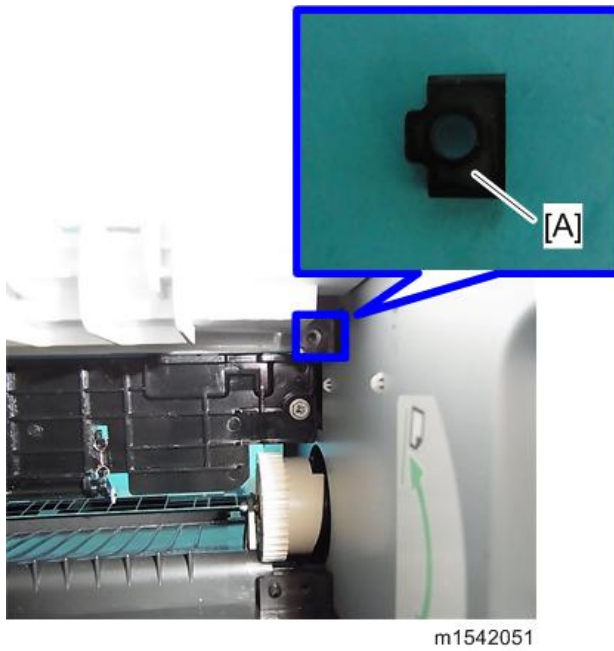

Replacement and Adjustment

**Reinstallation**

Pass the cable [A] of the fusing unit through the hole [B] outside, after setting the fusing unit.

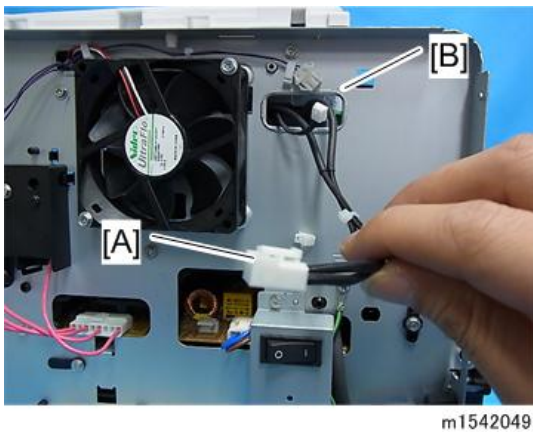

### ***After installing a new fusing unit***

1. Enter the "Printer Configuration" in SOM.
2. Select the "SP Mode 3" tab.
3. Click "Clear Fusing Unit EM Counter" and then click "OK".
4. Exit the SOM.

## **4.7.2 THERMOSTAT**

### **⚠ CAUTION**

- Do not recycle a thermostitch that is already opened. Safety is not guaranteed if you do this.

1. Fusing unit (page 4-28 "Fusing Unit")
2. Fusing upper cover [A] (🔩 x 4)

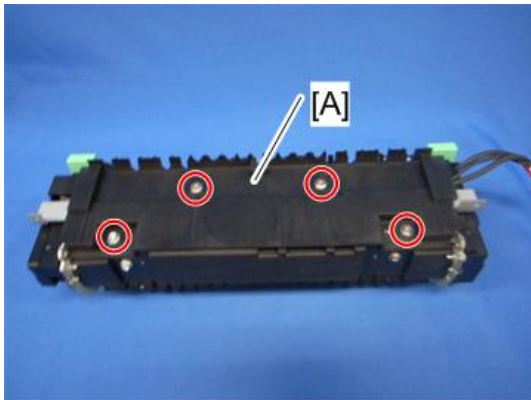

m012r141

3. Thermostat [A] (🔩 x 2)

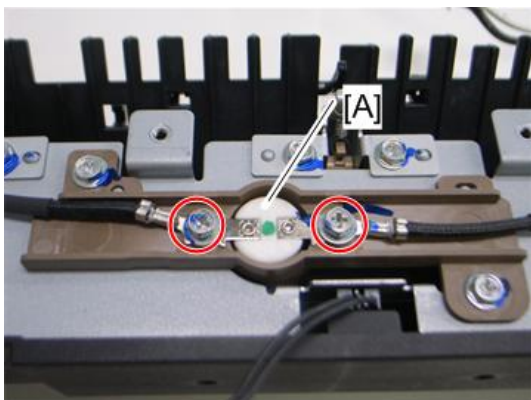

m016r142

### 4.7.3 THERMISTOR

1. Fusing unit (page 4-28 "Fusing Unit")
2. Fusing upper cover [A] (🔩 x 4)

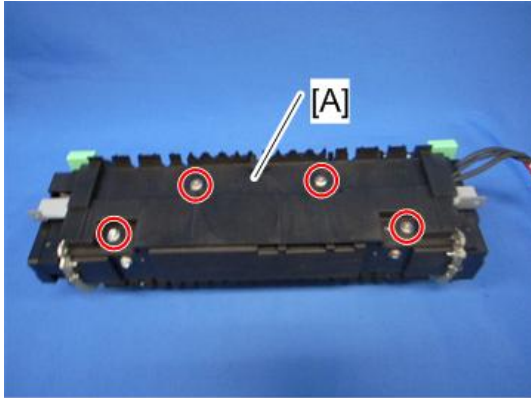

m012r141

3. Fusing front cover [A] (🔩 x 2)

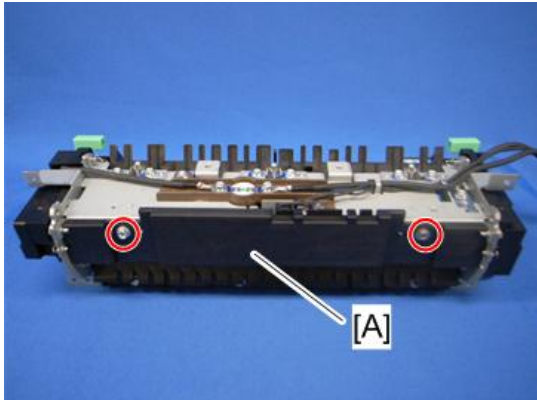

m012r132

4. Thermistor [A] (🔩 x 1)

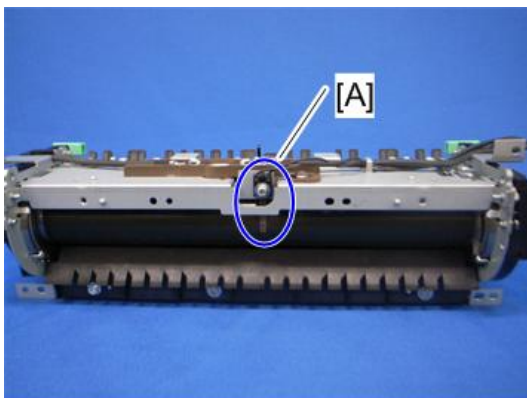

m012r131

### 4.7.4 FUSING LAMP

1. Fusing unit (page 4-28 "Fusing Unit")
2. Fusing side covers [A] (🔩 x 2 each)

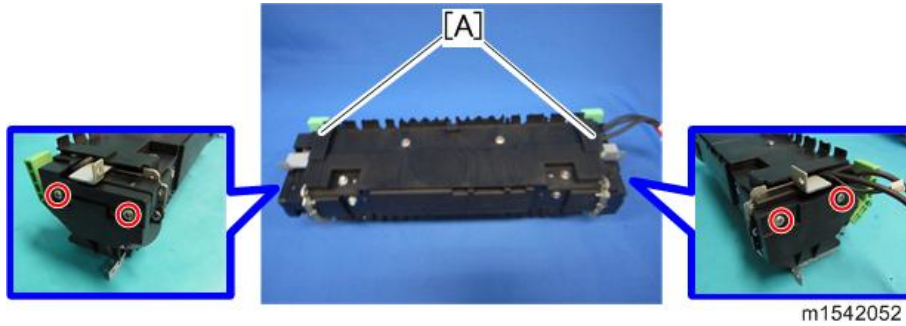

3. Turn over the fusing unit.
4. Ground wires (🔩 x 1 each)



5. Fusing lamp [A]

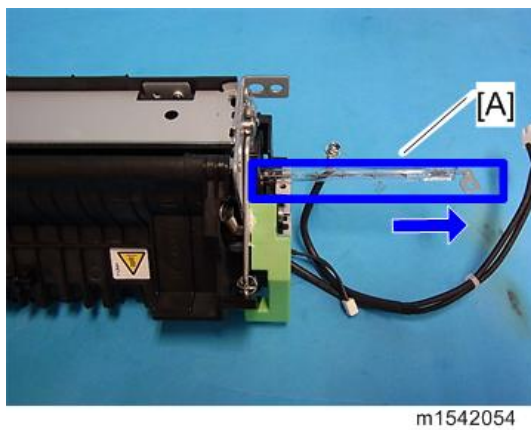

**When reinstalling the fusing lamp**

The flat terminal [A] must be placed on the right side of the fusing unit (fusing cable side).



m1542055

**4.7.5 HOT ROLLER**

1. Fusing lamp (page 4-32 "Fusing Lamp")
2. Brackets [A] (🔧 x 2 each)

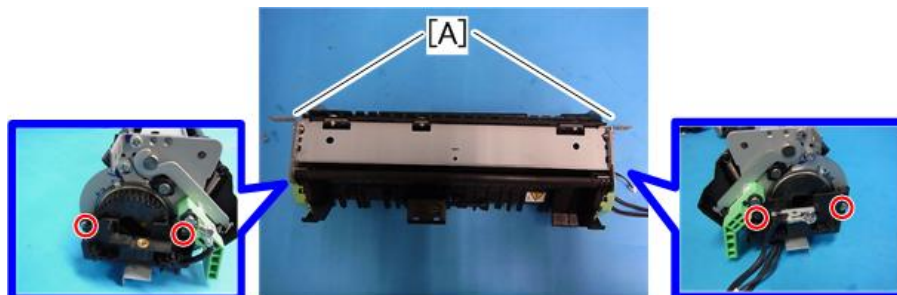

m1542056

3. Turn over the fusing unit.
4. Fusing upper cover [A] (🔧 x 4)

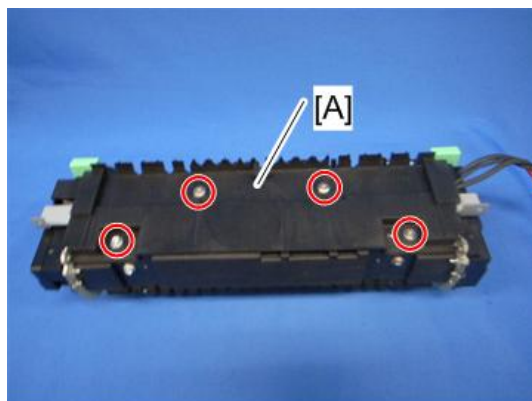

m012r141

5. Fusing front cover [A] (🔧 x 2)

Replacement and Adjustment

## Fusing and Exit

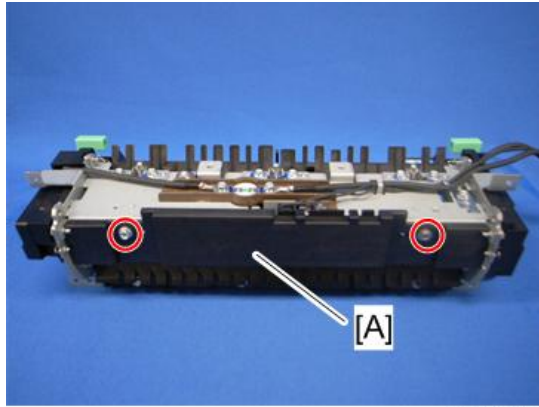

m012r132

6. Fusing entrance guide [A] (⌀ x 3)

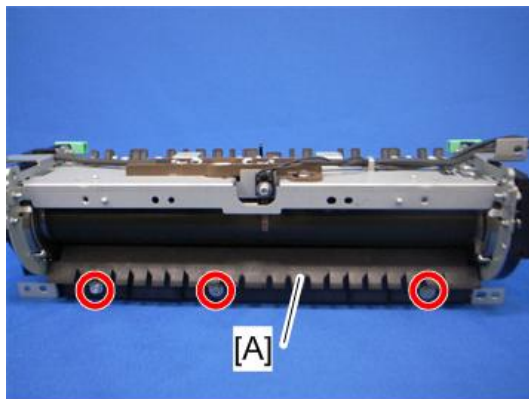

m1542057

7. Thermistor (page 4-31 "Thermistor")
8. Hot roller stripper pawls (page 4-36 "Hot Roller Stripper Pawls")
9. Ground plate [A] (⌀ x 2 each)

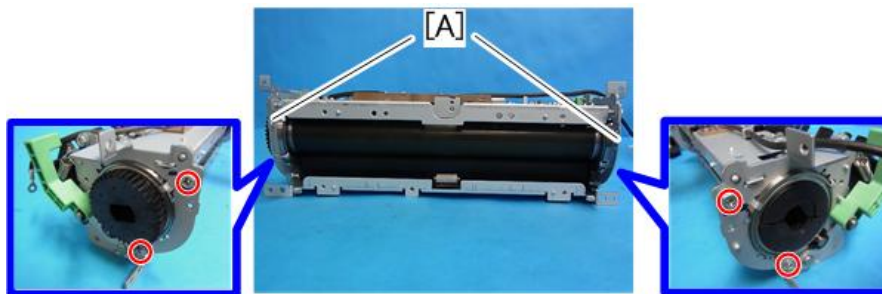

m1542058

10. Quenching brush [A] (⌀ x 1)

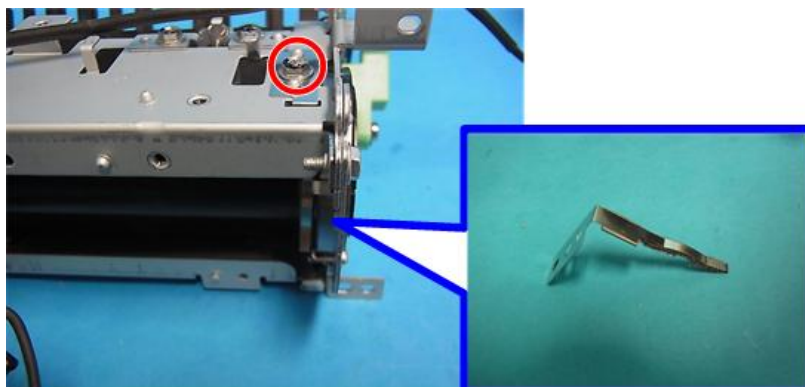

m1542059

11. Hot roller [A]

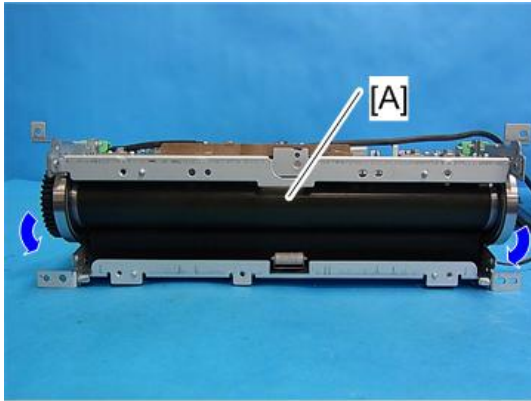

m1542060

12. Remove the C-ring x 2, gear x 1, cap x 1, bushing x 2 from the Hot Roller.



m1542061

Replacement  
and Adjustment

### 4.7.6 PRESSURE ROLLER

1. Hot roller (page 4-33 "Hot Roller")
2. Pressure roller [A] (Bearing x 2)

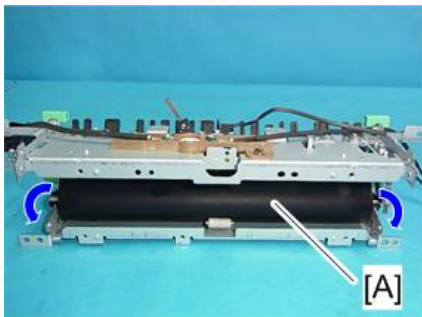

m1542062

### 4.7.7 HOT ROLLER STRIPPER PAWLS

1. Fusing unit (page 4-28 "Fusing Unit")
2. Fusing upper cover (page 4-30 "Thermostat")
3. Metal holders [A] (1 holder for each pawl:  x 2 each)

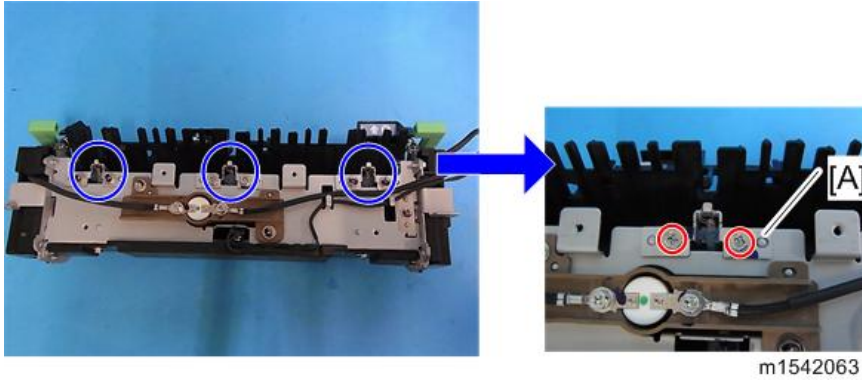

4. Hot roller stripper pawls [A] (1 spring for each pawl)

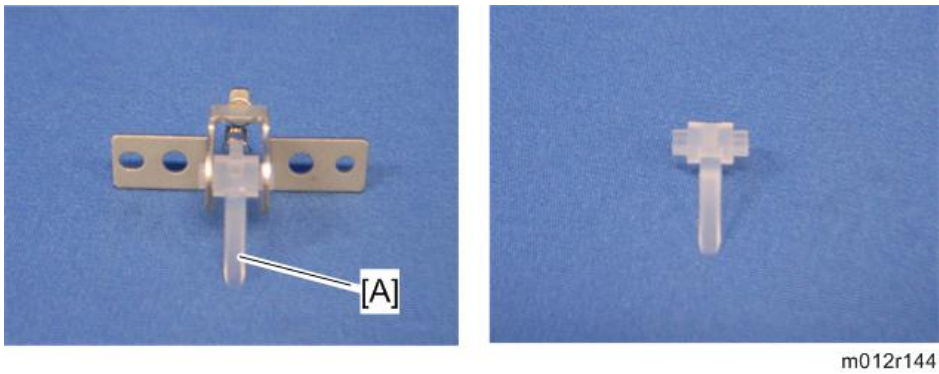

### 4.7.8 PAPER EXIT SENSOR

1. Rear cover (page 4-7 "Rear Cover")
2. Paper exit sensor [A] ( x 1, 3 hooks)

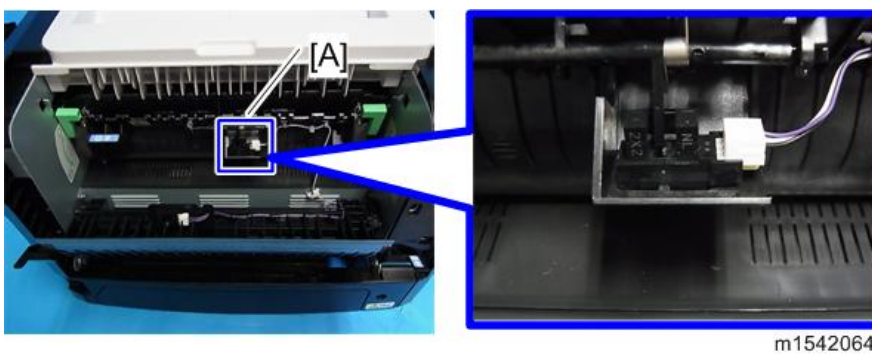

## 4.8 DRIVE

### 4.8.1 MAIN MOTOR

1. Left cover (page 4-5 "Left Cover")
2. Harness guide plate [A] (🔩 x 3, 🛠️ x 2, 📏 x 1)
3. Main motor [B] (🔩 x 4, 🛠️ x 1)

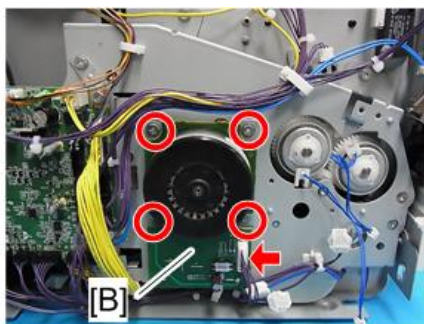
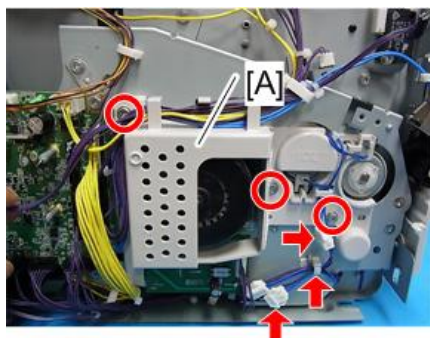

m1542065

### 4.8.2 DRIVE UNIT

1. Left cover (page 4-5 "Left Cover")
2. Main board (page 4-40 "Main board")
3. Harness guide plate [A] (🔩 x 3, 🛠️ x 2, 📏 x 1)
4. Drive unit [B] (🔩 x 5, 🛠️ x 1, 📏 x 2, timing belt)

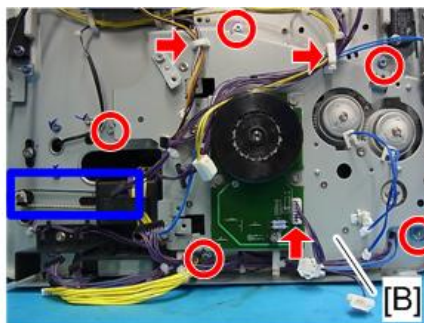
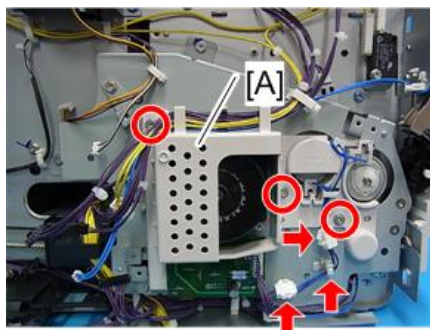

m1542066

### 4.8.3 DUPLEX MOTOR

1. Left cover (page 4-5 "Left Cover")
2. Duplex motor [A] (🔧 x 2, 🛠️ x 1, 📏 x 1)

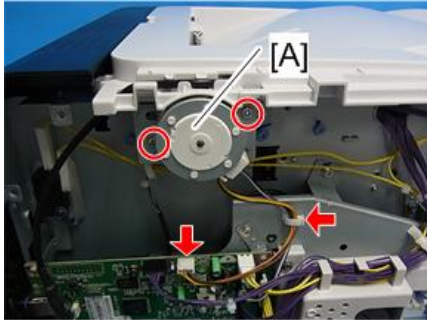

m1542067

## 4.9 ELECTRICAL COMPONENTS

### **⚠ CAUTION**



- When replacing a fuse, always use a fuse of the correct rating. Never use a fuse with the wrong rating. If you do, the machine may be damaged.

### 4.9.1 LAYOUT OF PC BOARDS



[A]	Main board
-----	------------

## 4.9.2 MAIN BOARD

1. Left cover (page 4-5 "Left Cover")
2. Main board [A] (  x 4, all s)

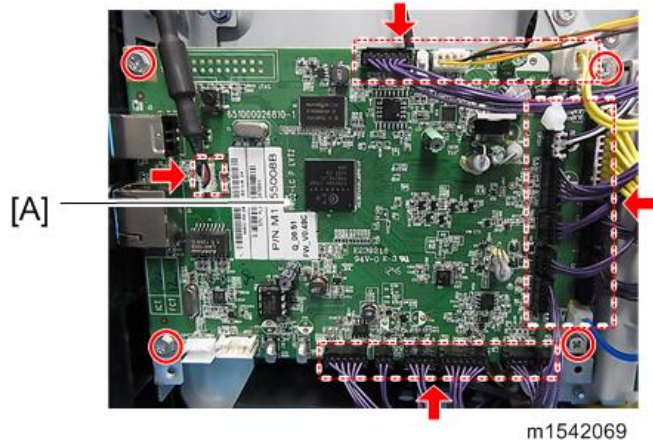

m1542069

### ↓ Note

- Do not connect any connectors to JRS1 and JRS2 when reinstalling the Main board [A]. JRS1 and JRS2 are only used at the factory.
- Do not change the dip switch. The dip switch is only for factory use.

3. EEPROM [A]

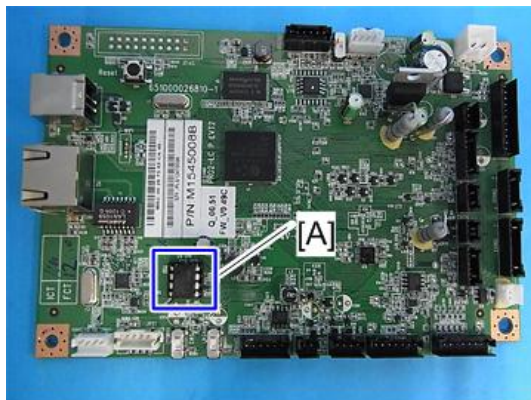

m1542070

**Before installing the new main board**

The following preparation is needed.

- Install the printer driver and the SOM.
- Create a USB port for the printer. (Figure 1)
- Verify the PnP ID of the printer. (Figure 2)

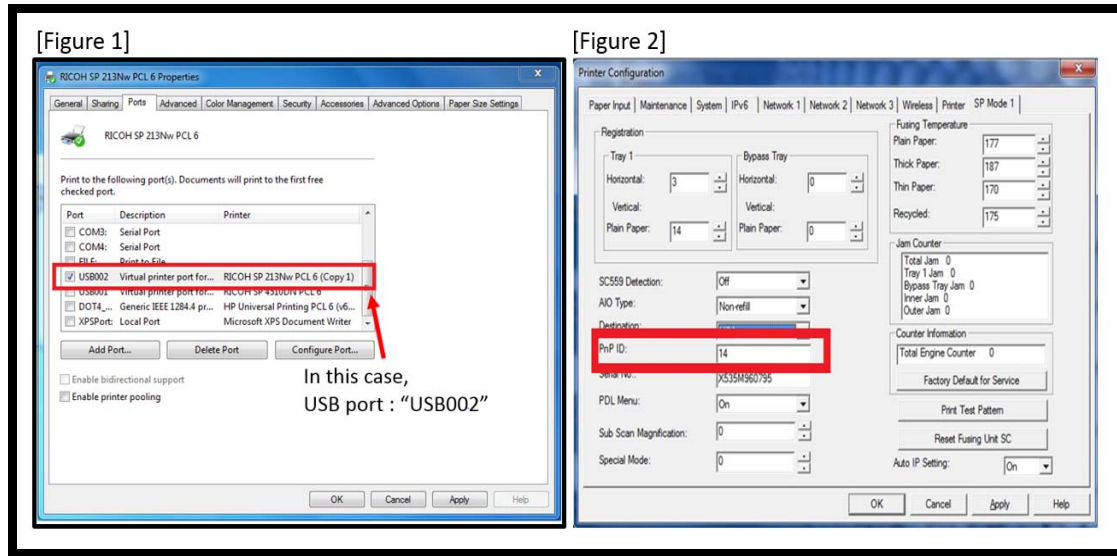

**Replacement and Adjustment**

**Procedure:**

1. Replace the main board.
2. Turn ON the device.
3. Connect SOM to the device with a USB cable.
4. Verify that the port is identical to that created in the preparation step (Figure 1). If not, correct the port.
5. Type in the PnP ID verified in the preparation step (Figure 2).
6. Set Destination code according to the following table.

0x01	NA
0x02	EU/ASIA
0x04	CHN
0x05	TAIWAN

7. Reboot the device.

### ***When installing the new main board***

1. Remove the EEPROM from the old main board.
2. Install it on the new Main board after replacing the main board.
3. Replace the EEPROM if the EEPROM on the old main board is defective.

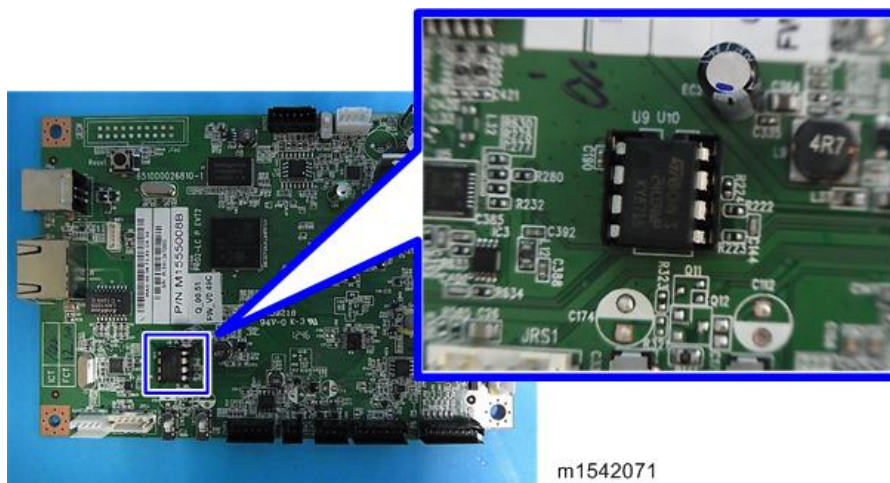

#### **↓ Note**

- Keep the EEPROM away from any objects that can cause static electricity. Static electricity can damage EEPROM data.
- Make sure that the EEPROM is correctly installed on the main board.

### ***EEPROM***

- Replacement procedures for the new EEPROM are included in the “page 4-40 "Main board"” replacement procedure. Refer to “page 4-40 "Main board"” for details.
- Do the following settings after installing a "new" EEPROM.
  - Input the PnP Name, Destination with SOM.
  - Adjust the Registration with SOM.
  - Input the serial number on the serial number input display after installing the new EEPROM

#### **↓ Note**

- Ask your supervisor about how to access the serial number input display.

### 4.9.3 PSU

The replacement procedure of the PSU is difference, due to the location of the PSU between the two models. The **M154/M155/M147/M175** PSU is installed at the bottom of the machine and the **M287/M289** is behind the right side cover.

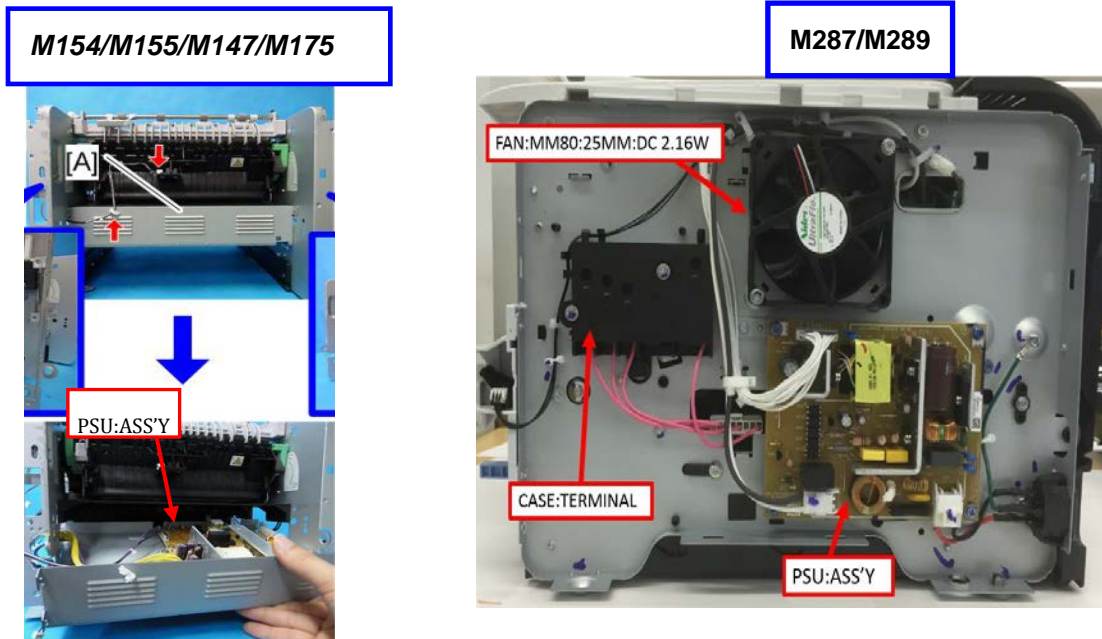

### ⚠ CAUTION

**NEVER touch the areas outlined in red, in the photos below, to prevent electric shock caused by a residual charge.**

**A residual charge of about 100V-400V remains on the PSU board for several months even when the board has been removed from the machine after turning off the machine power and unplugging the power cord.**

D2875313 : NA/TWN: PSU ASS'Y

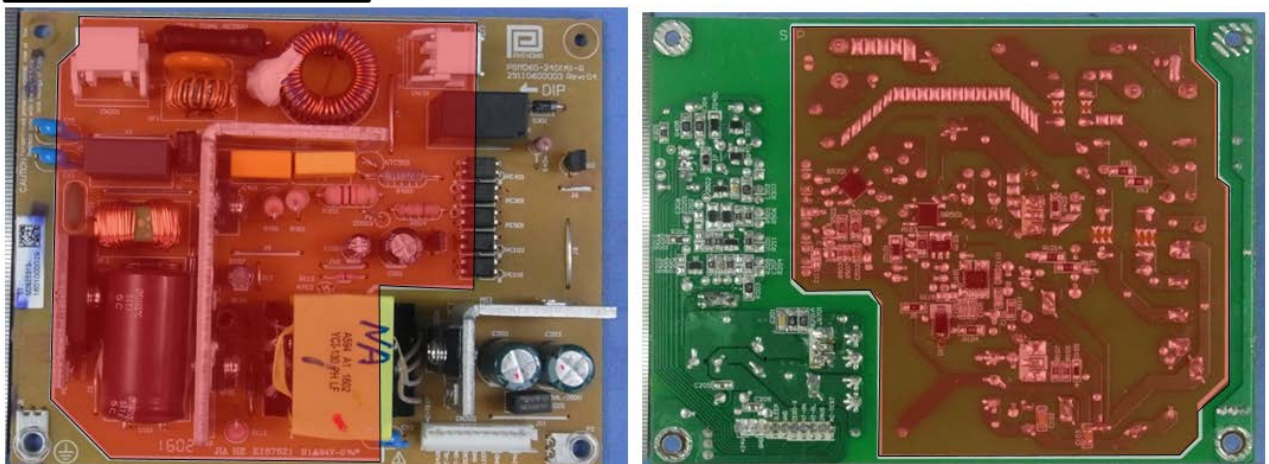

D2875312 : EU/AA/IND: PSU ASS'Y

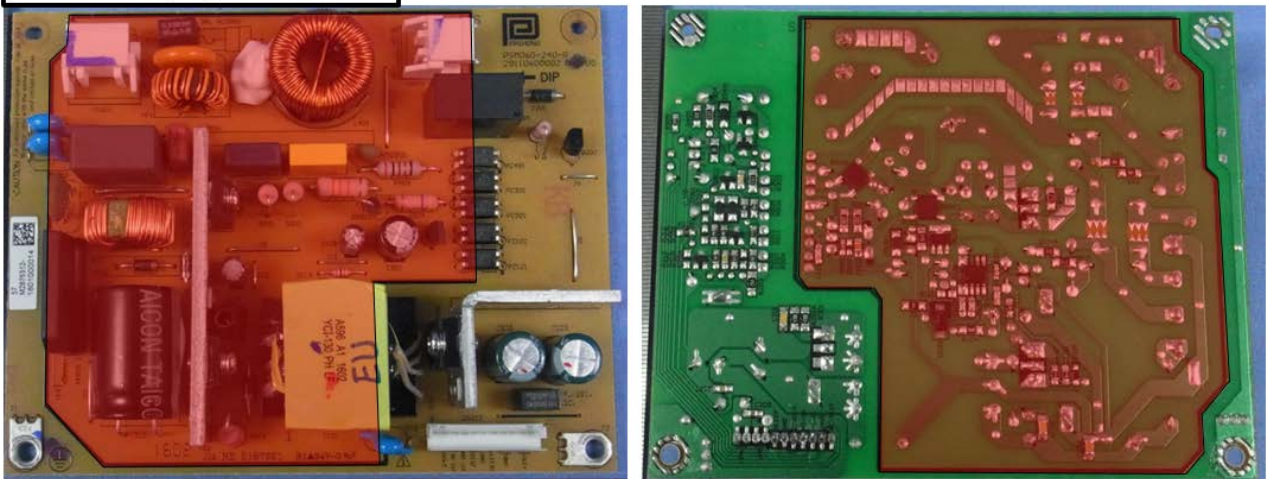

### Replacement Procedure M154/M155/M147/M175

1. Pull out the standard paper tray.
2. Front cover (page 4-3 "Front Cover")
3. Rear cover (page 4-7 "Rear Cover")
4. Left cover (page 4-5 "Left Cover")
5. Right cover (page 4-8 "Right Cover")
6. Top cover (page 4-10 "Top Cover")
7. Main board (page 4-40 "Main board")
8. Drive unit (page 4-37 "Drive Unit")
9. Bracket [A] (🔩 x 2, 📏 x 1)

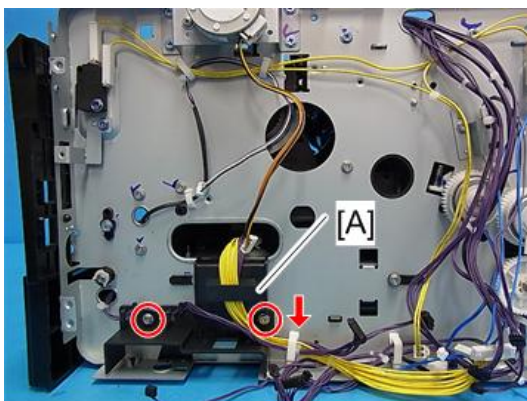

m1542072

10. Disconnect three connectors on the left frame.
11. Main power switch bracket [A] on the right frame (🔩 x 2)
12. Remove the main power cord [B] as shown below (📏 x 2, ground screw x 1).

Replacement and Adjustment

## Electrical Components

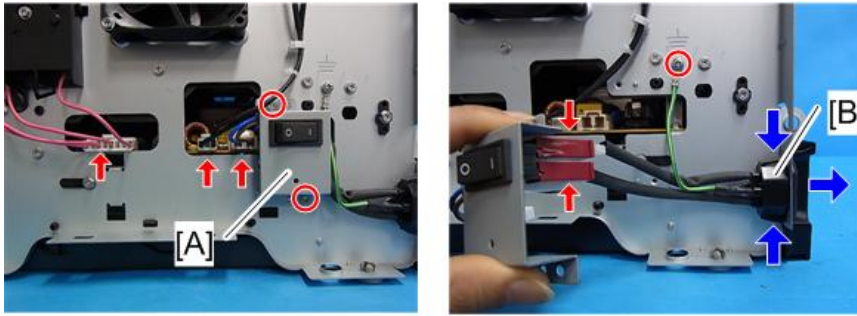

m1542073

13. Rear lower cover [A] (🔩 x 3).

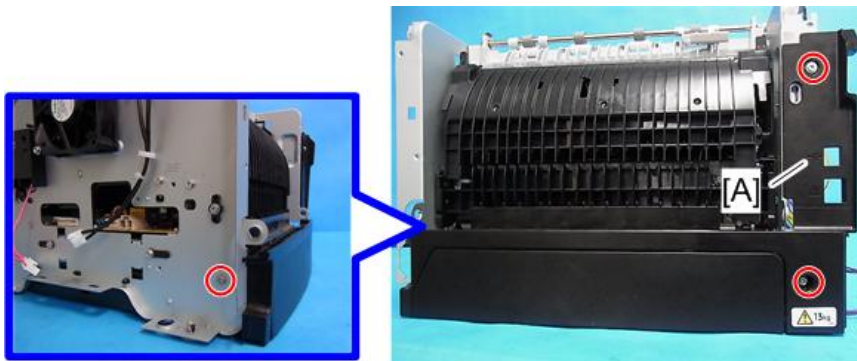

m1542074

14. Release the lock [A], and then remove the entrance guide [B] (🔧 x 1).

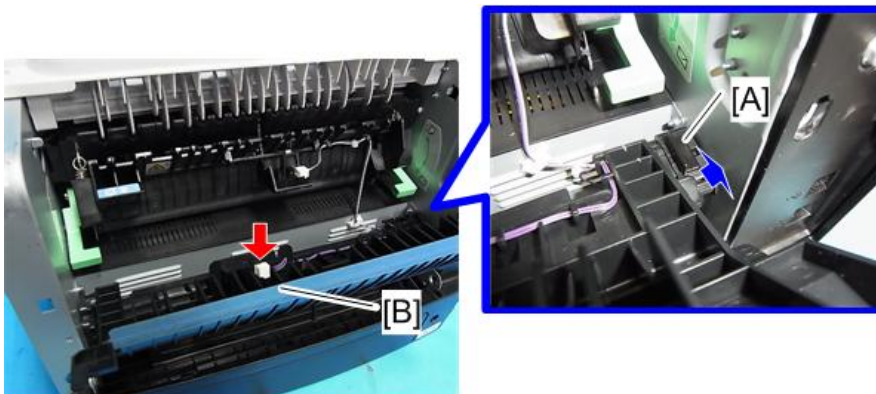

m1542047

15. Duplex cover [A] (🔩 x 2, bushing x 2)

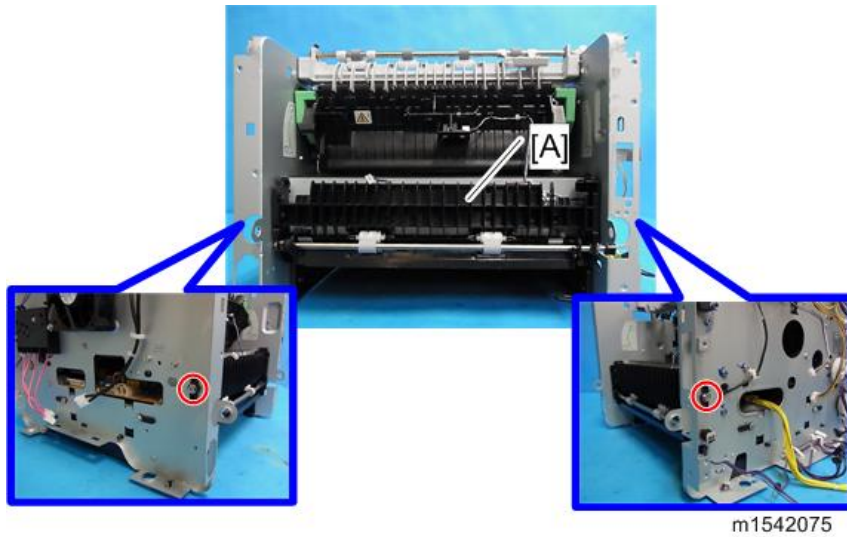

16. Set the machine with the front side facing down, resting on the table.
17. Release the link [A] (Ⓢ x 1)

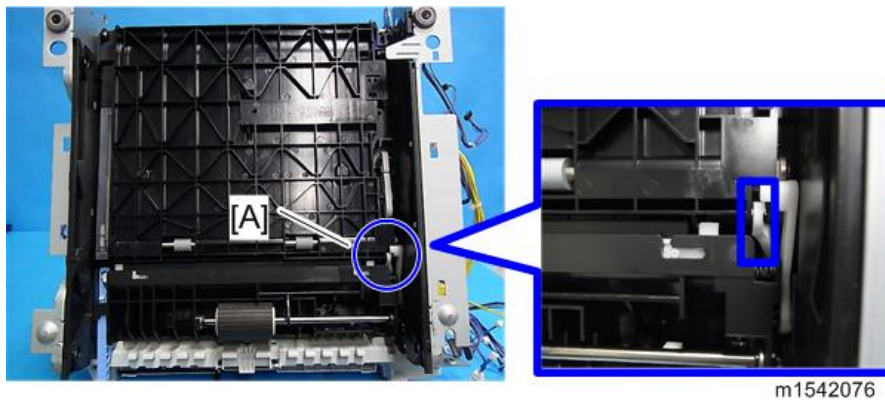

18. Duplex transport guide [A] (Ⓢ x 4 ,bushing x 4, Ⓢ x 1, gear x 1)

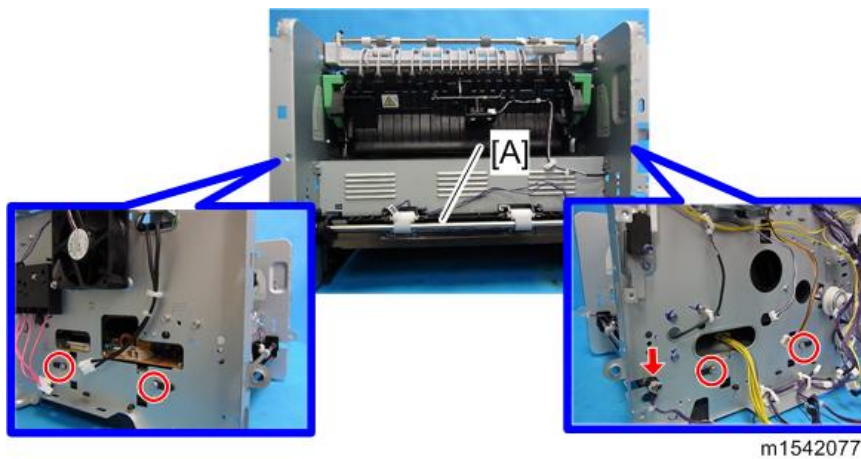

19. PSU / HVP unit [A] (Ⓢ x 4, Ⓢ x 1, Ⓢ x 1)

Replacement and Adjustment

Electrical Components

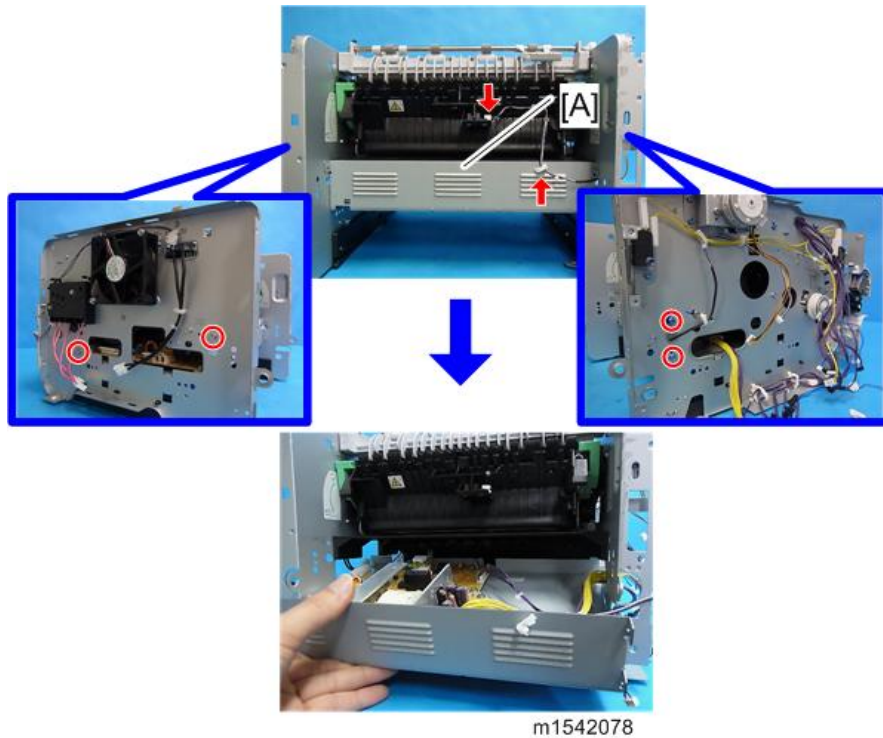

20. PSU [A] ( x 4, x 1)

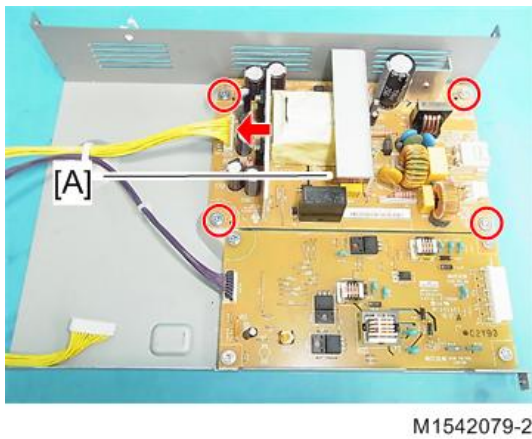

**Replacement Procedure M287/M289**

1. Pull out the standard paper tray.
2. Front cover (page 4-3 "Front Cover")
3. Rear cover (page 4-7 "Rear Cover")
4. Right cover (page 4-8 "Right Cover")

[Right side after taking the Right cover]

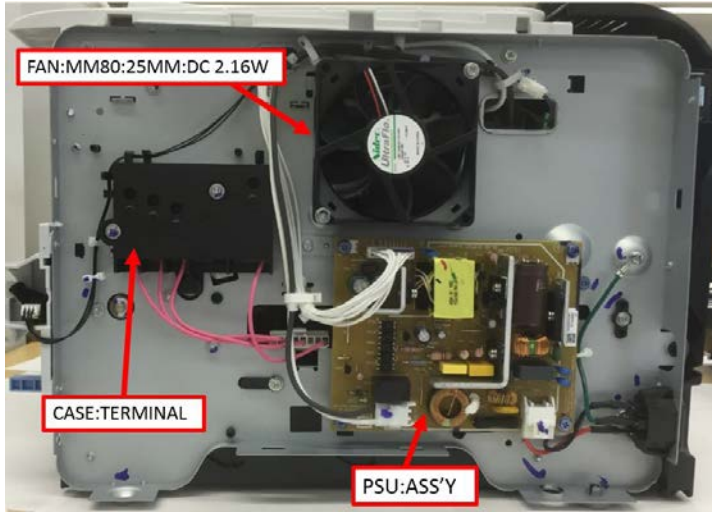

Replacement and Adjustment

5. Remove the PSU:ASS'Y. (⚙️ x4, harness x3, clamp x1)

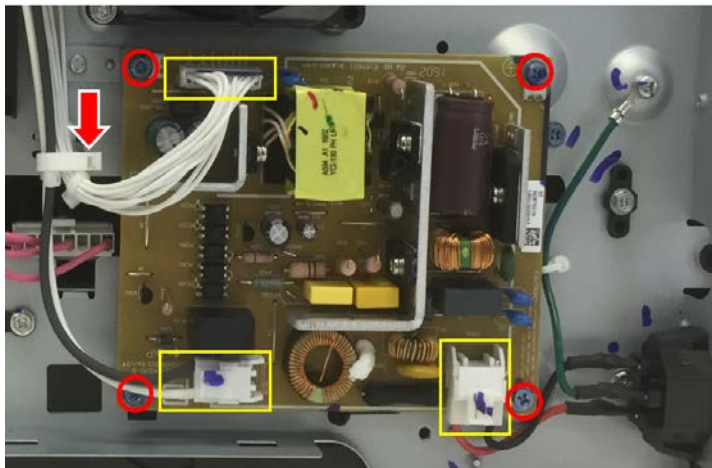

6. PSU:ASS'Y

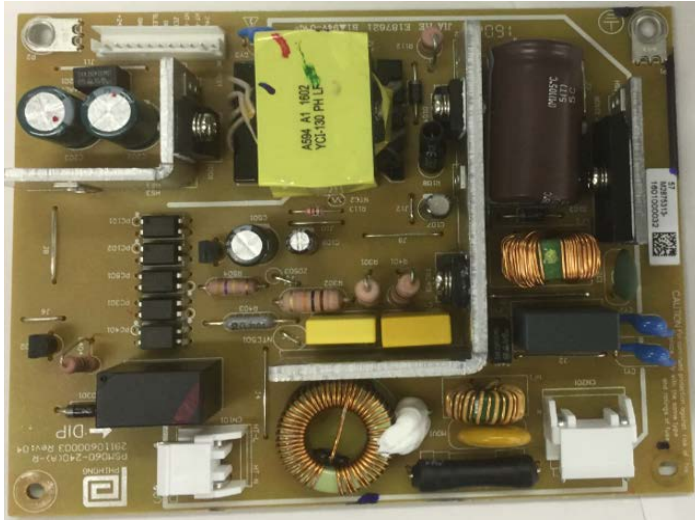

4.9.4 HVP

1. PSU / HVP unit (page 4-42 "

PSU")

2. HVP [A] (🔩 x 4, 🛠️ x 1).

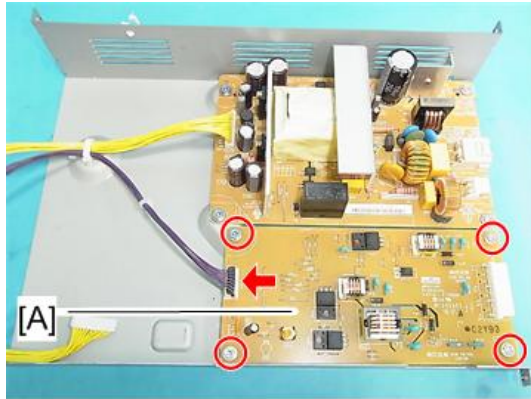

m1542079

### 4.9.5 CHARGE TERMINAL CASE

1. Right cover (page 4-8 "Right Cover")
2. Charge terminal case [A] with the harness (🔌 x 2, 📌 x 1, 2 hooks)

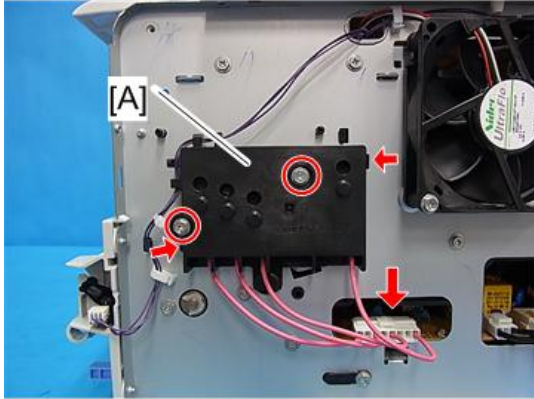

m1542080

3. Harness [A] (🔌 x 4)
4. Four springs and terminal pins [B].

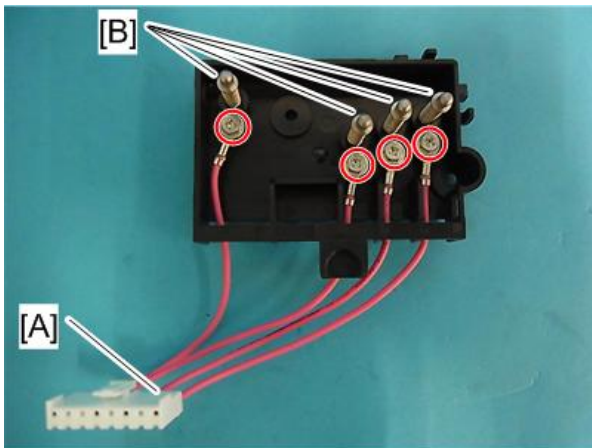

m1542081

## 4.9.6 COOLING FAN

1. Right cover (page 4-8 "Right Cover")
2. Top cover (page 4-10 "Top Cover")
3. Cooling fan [A] (🔧 x 2, 🛠️ x 1, 📏 x 2)

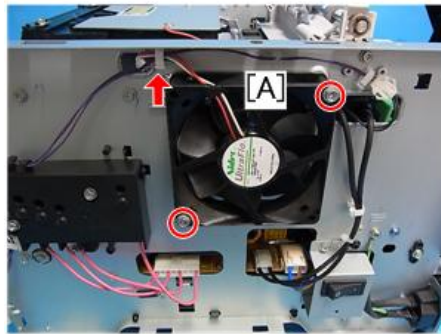
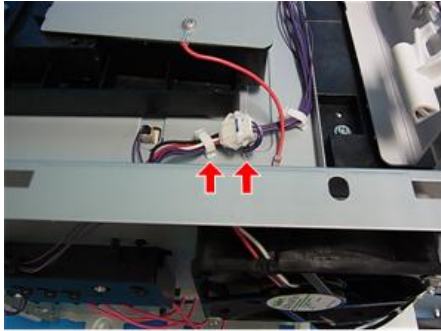

m1542082

### CAUTION

- Install the cooling fan [A] with its decal facing the outside of the machine.

### 4.9.7 WIRELESS LAN BOARD (FOR M155, M175)

1. Left cover (page 4-5 "Left Cover")
2. Top cover (page 4-10 "Top Cover")
3. Remove the Wireless LAN board [A] from the top cover (hook).

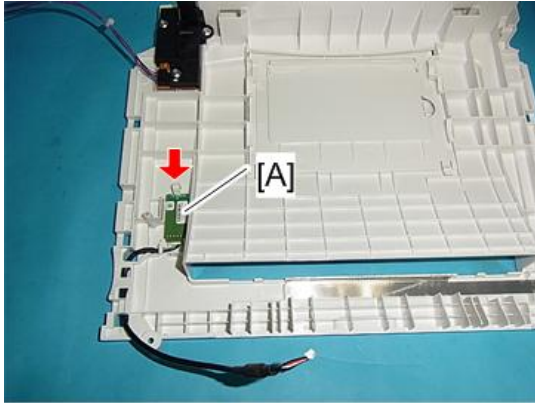

m1542083

## 4.10 DUPLEX

### 4.10.1 RELAY SENSOR

1. Rear cover (page 4-7 "Rear Cover")
2. Relay sensor [A] (  x 1, 3 hooks)

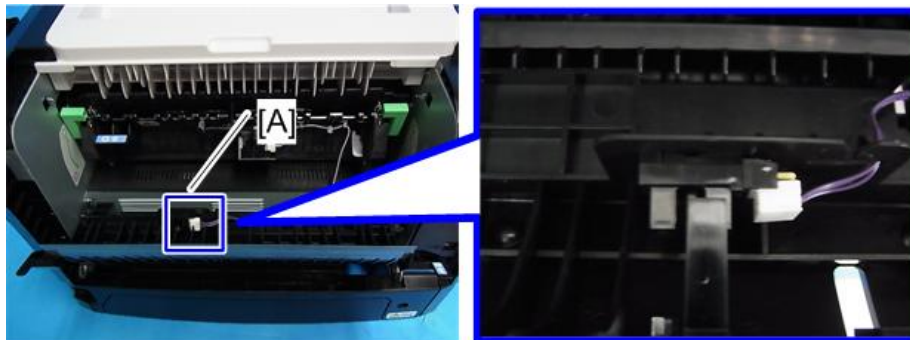

m1542084

### 4.10.2 INVERTER SENSOR

1. Duplex transport guide (page 4-42 "PSU")
2. Inverter sensor [A] (  x 1, 3 hooks)

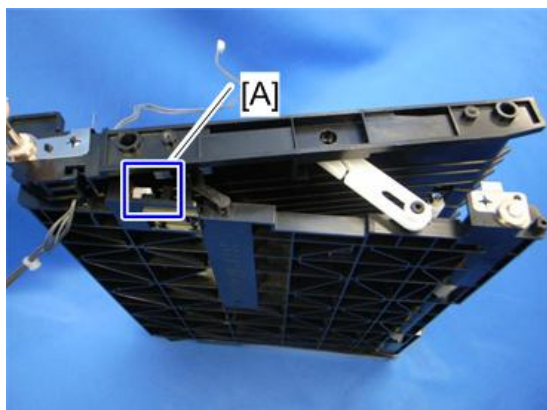

m016r160



# SERVICE TABLES

REVISION HISTORY		
Page	Date	Added/Updated/New
		None



---

## 5. SERVICE TABLES

### 5.1 SMART ORGANIZING MONITOR

#### 5.1.1 OVERVIEW

SOM (Smart Organizing Monitor) is a utility which can check the status of a printer and set up a printer from a PC. This utility is executed from a printer driver.

#### 5.1.2 PRINTER DRIVER INSTALLATION (USB CONNECTION)

1. Close all applications currently running.
2. Check the following:
  - The printer's USB cable is disconnected
  - The printer's main power switch is turned off
3. Insert the CD-ROM into the CD-ROM drive.  
The installer starts.
4. Select the interface language, and then click [OK].
5. Click [DDST Printer Driver] or [PCL 6 Printer Driver].  
The software license agreement appears.
6. After reading the agreement, click [I accept the agreement.], and then click [Next >].
7. In the [Method to install printer driver] dialog box, clear the [Search for network printers.] check box, select the [Connect a printer using a USB cable.] check box, and then click [Next >].
8. Select this printer, and then click [Next >].  
A message appears, asking you to check that the USB cable is not connected and that the printer's main power switch is turned to off.
9. Check the USB cable and the printer status, and then click [Next >].
10. When the [<Auto-detect USB Port>] dialog box appears, connect this printer to the computer using a USB cable, and then turn the printer's main power switch on.  
USB auto detection begins.
11. When the dialog box asking you to use this printer as the default printer appears, click either key.
12. When a message appears informing you that the installation was successfully completed, click [Finish].

### 5.1.3 ENTERING THE PRINTER CONFIGURATION

To enter the service system setting;

1. Start the SOM utility.

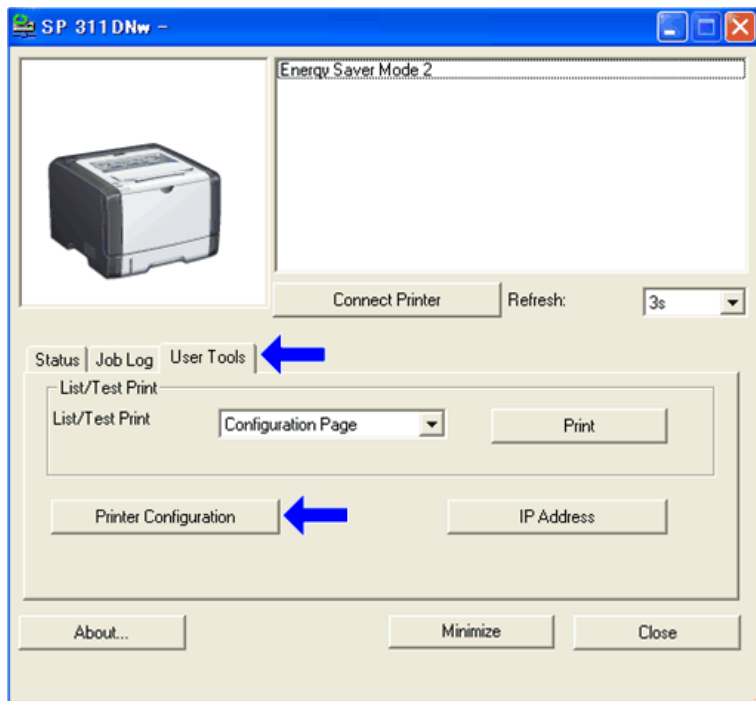

m1542108

2. Click the "User Tools" tab.
3. Click "Printer Configuration".
4. The "Access Code" entry dialog appears.

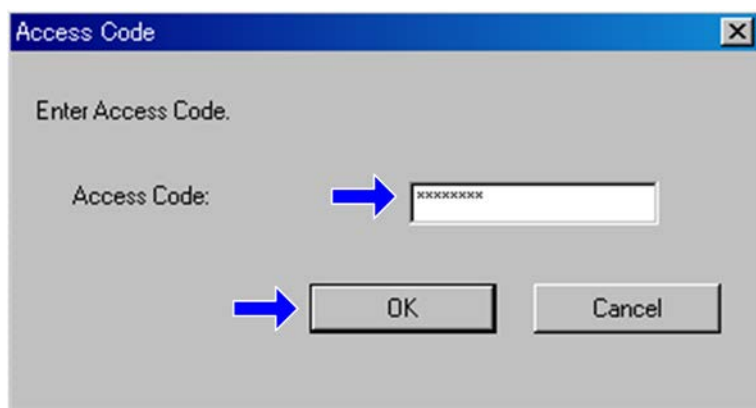

m012s502

5. Input the access code (for customer engineers).
6. Click the "OK" button.

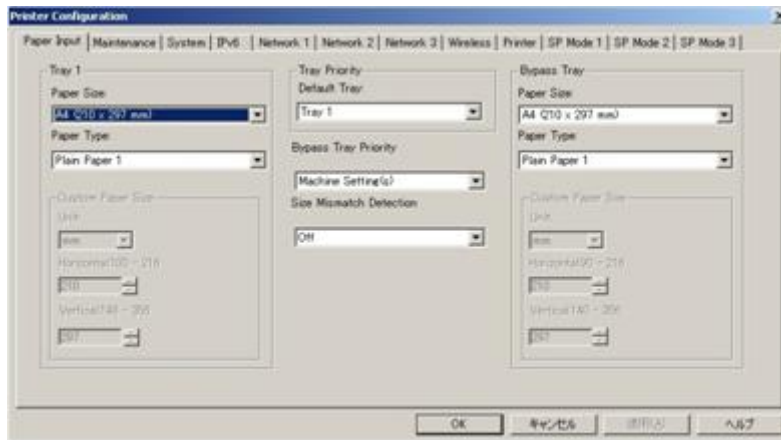

m1549000

7. The "Printer Configuration" GUI appears.

### 5.1.4 PRINTER CONFIGURATION MENU LIST

The SOM has the following printer configuration menus. Each menu contains various setting items. The details of each setting item are explained in this section below.

Menu	Description
Paper Input	Adjusts the paper type and size settings.
Maintenance	Adjusts the image registration and executes the color registration adjustment.
System	Adjusts the system settings of the machine.
IPv6	Adjusts network settings (IPv6).
Network 1	Adjusts network settings (Information, Interface, TCP/IP).
Network 2	Adjusts network settings (IPX, SMTP).
Network 3	Adjusts network settings (SNMP, Apple Talk).
Wireless	Adjusts network settings (Wireless).
Printer	Adjusts the printer driver settings (PCL, PS).
SP mode 1	Adjusts and executes service program modes.
SP mode 2	Adjusts and executes service program modes.
SP mode 3	Adjusts and executes service program modes.

**Paper Input**

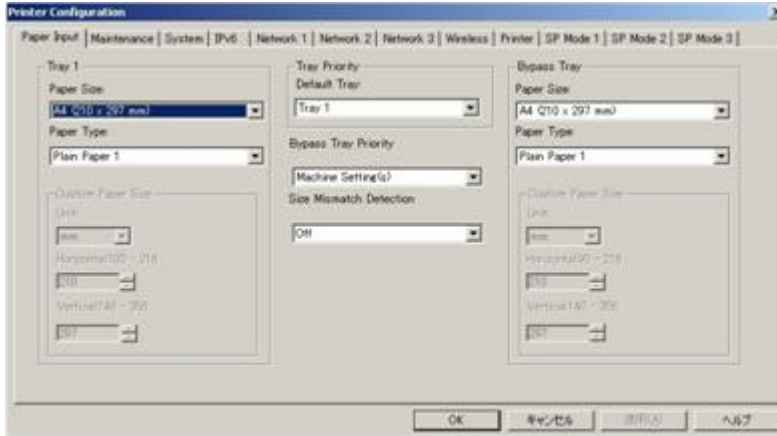

m1549000

Item	Selections	Remarks
Tray 1 Paper Size (standard)	A4 */ B5/ A5/ B6/ A6/ Legal/ Letter*/ Half Letter/ Executive/ 8" x 13"/ 8.5" x 13"/ Folio/ 16K/ Custom Paper Size	*: Default (NA: Letter, EU: A4) The selectable paper sizes depend on the model. For details, refer to the "Supported Paper Size List".
Tray 1 Paper type (standard)	Thin Paper/ Thick Paper 1/ Thick Paper 2 / Plain Paper 1*/ Recycled Paper/ Color Paper/ Preprinted Paper/ Prepunched Paper/ Letterhead/ Bond Paper/ Cardstock/ Labels	*: Default The selectable paper types depend on the model. For details, refer to the "Supported Paper Types" in the "Specifications" chapter.
Bypass Tray Paper Size	A4 */ B5/ A5/ B6/ A6/ Legal/ Letter*/ Half Letter/ Executive/ 16K/ 4 1/8" x 9 1/2"/ 3 7/8" x 7 1/2"/ C5 Env/ C6Env/ DL Env/ Custom Paper Size	-
Bypass Tray Paper type	Thin Paper/ Thick Paper 1/ Thick Paper 2 / Plain Paper 1*/ Recycled Paper/ Color Paper/ Preprinted Paper/ Prepunched Paper/ Letterhead/ Bond Paper/ Cardstock/ Labels/ Envelope/ OHP	-

Service Tables

Item	Selections	Remarks
Custom Paper Size : Tray1	Horizontal : 100-216mm Vertical : 148-356mm	3.54 – 8.50 inch. Precision is two digits after the decimal point in inch or one digit after the decimal point in mm. If an input value is more than the maximum value, then it will be treated as the maximum value. If an input value is less than the minimum value, then it will be treated as the minimum value.
Custom Paper Size : Bypass	Horizontal : 90-216mm Vertical : 140-356mm	3.54 – 8.50 inch. Precision is two digits after the decimal point in inch or one digit after the decimal point in mm. If an input value is more than the maximum value, then it will be treated as the maximum value. If an input value is less than the minimum value, then it will be treated as the minimum value.
Tray Priority: Default Tray	Tray1 *	-
	Bypass Tray	
Bypass Tray Priority	Machine Setting(s)	-
	Any Size/Type	
	Any Custom Size/Type	
Size Mismatch Detection	On / Off*	-

“\*” indicates the factory default value.

## Maintenance

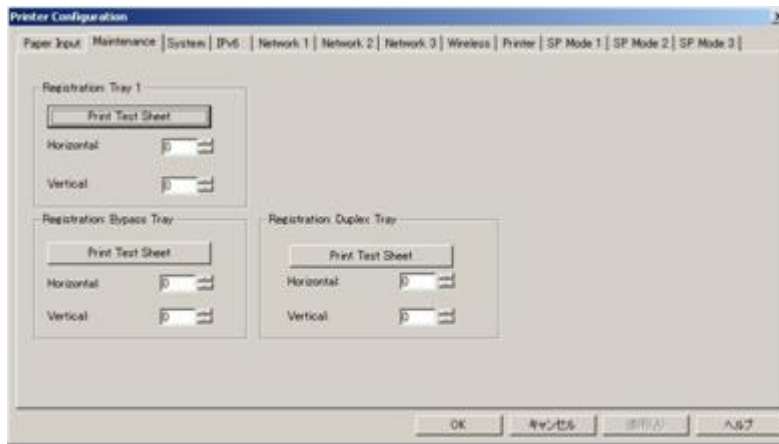

m1549001

Group (Tab)	Item	Selections	Remarks
Registration Tray 1	Print Test Sheet button	-	Sends a PCL command to the printer to print a test sheet. It is disabled when tray 1 is not installed.
	Adjustment Horizontal	(-15 to +15) step	0.1 mm per step. Range is -15 mm to +15 mm. If the machine settings are reset to the factory defaults, this value does not change.
	Adjustment Vertical	(-15 to +15) step	0.1 mm per step. Range is -15 mm to +15 mm. If the machine settings are reset to the factory defaults, this value does not change.
Registration Bypass Tray	Print Test Sheet button	-	Sends a PCL command to the printer to print a test sheet.
	Adjustment Horizontal	(-15 to +15) step	0.1 mm per step. Range is -15 mm to +15 mm.
	Adjustment Vertical	(-15 to +15) step	0.1mm per step. Range is -15 mm to +15 mm.
Registration Duplex Tray	Print Test Sheet button		Sends a PCL command to the printer to print a test sheet.

## Smart Organizing Monitor

Group (Tab)	Item	Selections	Remarks
	Adjustment Horizontal	(-15 to +15) step	0.1 mm per step. Range is -15 mm to +15 mm.
	Adjustment Vertical	(-15 to +15) step	0.1mm per step. Range is -15 mm to +15 mm.

"\*" indicates the factory default value.

## System

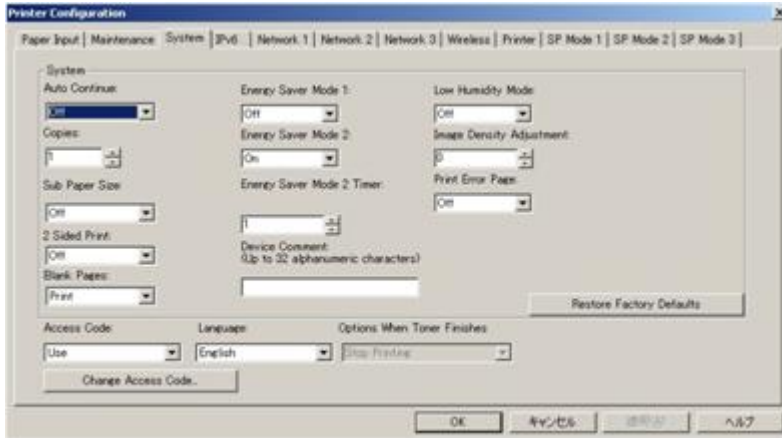

m1549002

Item	Selections	Remarks
Auto Continue	On/Off *	-
Copies	1*-999	-
Sub Paper Size	Off */ Auto	-
2 Sided Print	Off */ Short Edge Bind/ Long Edge Bind	-
Blank Page Print	Print */ Not Print	"Manual Duplex/Cover" has higher priority than the "Blank Pages" setting.
Energy Saver Mode 1	On	-
	Off *	-
Energy Saver Mode 2	On *	-
	1~240 minutes	-
	30 Seconds*	-
Energy Saver Mode 2 Timer	1*-240 min	-
Low Humidity Mode	On	-

Item	Selections	Remarks
	Off *	-
Image Density Adjustment	-3 to 3 (0*)	-
Print Error Page	On	-
	Off *	-
Device Comment	Null string*	Up to 32 alphanumeric characters. The factory default is 'null string'.
Restore to Factory Default button	-	Restores all settings to the factory default settings for the market area setting.
Language	English *	The factory setting is English if the market is NA, EU or ASIA.
	French	
	German	
	Italian	
	Spanish	
	Dutch	
	Danish	
	Swedish	
	Norwegian	
	Portuguese	
	Polish	
	Czech	
	Hungarian	
	Finnish	
Japanese		
Simplified Chinese		

Item	Selections	Remarks
	Russian	
	Brazilian	
	Turkish	
Access Code	Use *	-
	Do not use	
Access code change button	-	Changes the access code. The button is grey if the Access code is set to "Do not use".

"\*" indicates the factory default value.

## IPv6

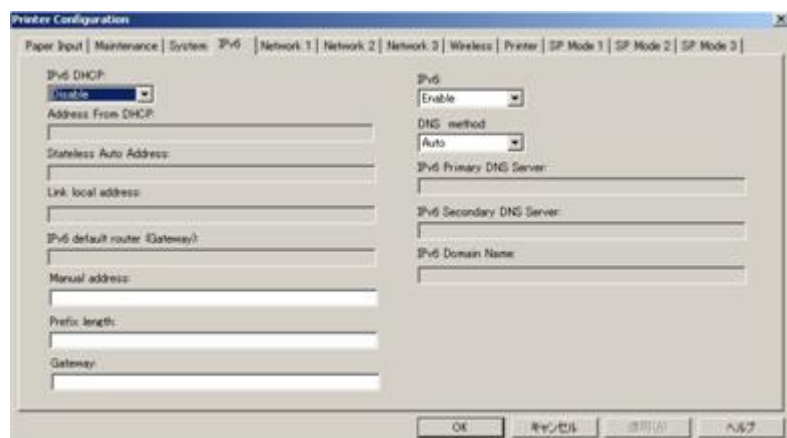

m1549003

Item	Selections	Remarks
IPv6 DHCP	Disable*/Enable	-
Address From DHCP	-	Displays Address from DHCP
Stateless Auto Address	-	Displays Stateless Auto Address.
Link Local Address	-	Displays Link Local Address.
IPv6 default router (Gateway)	-	Displays IPv6 Default Gateway.
Manual Address	-	Input IPv6 Address Manually.
Prefix length	-	Input Prefix length.
Gateway	-	Input Gateway.
IPv6	Disable*/Enable	-
DNS method	Auto*/Manual	-
IPv6 Primary DNS Server	-	-
IPv6 Secondary DNS Server	-	-
IPv6 Domain Name	-	-

\*\* indicates the factory default value.

## Network 1

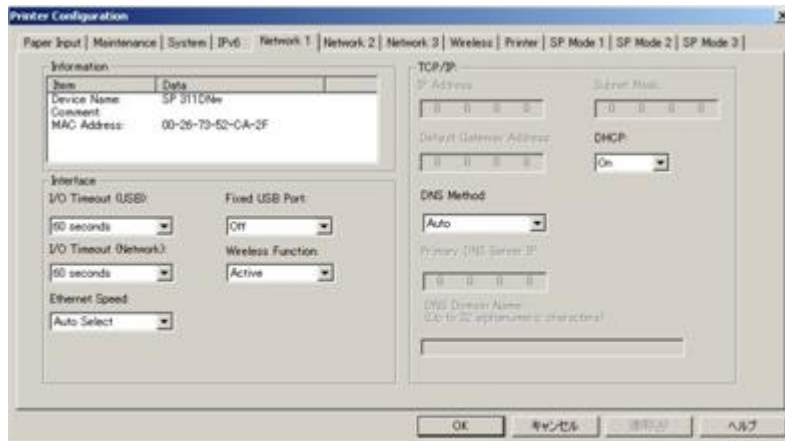

m1549004

Group (Tab)	Item	Selections	Remarks
Information	Device Name		String length is 32
	Comment		String length is 32
	Mac Address		
TCP/IP	IP Address	xxx.xxx.xxx.xxx	This setting is not available if DHCP is enabled. If this setting is changed, the printer power must be turned off/on for the new setting to take effect. The default setting is "192.0.0.192" when DHCP is off.
	Subnet Mask	xxx.xxx.xxx.xxx	This setting is not available if DHCP is enabled. If this setting is changed, the printer power must be turned off/on for the new setting to take effect. Will show all zero if network initialization is not finished. Any change will be ignored before the end of network initialization. The default setting is "255.255.255.0" when DHCP is off.

Group (Tab)	Item	Selections	Remarks
	Default Gateway Address	xxx.xxx.xxx.xxx	<p>This setting is not available if DHCP is enabled.</p> <p>If this setting is changed, the printer power must be turned off/on for the new setting to take effect.</p> <p>Will show all zero if network initialization is not finished. Any change will be ignored before the end of network initialization.</p> <p>The default setting is "192.0.0.192" when DHCP is off.</p>
TCP/IP	DHCP	On */ Off	<p>If this setting is changed, the printer power must be turned off/on for the new setting to take effect.</p>
	DNS Method	Auto */ Manual	
	Primary DNS Server IP	xxx.xxx.xxx.xxx	<p>Up to 32 alphanumeric characters. This setting is not available if DHCP is enabled.</p> <p>The default setting is "0.0.0.0" when DHCP is off.</p> <p>The setting when DHCP is changed from on to off is the previous setting when DHCP was on.</p> <p>If this setting is changed, the printer power must be turned off/on for the new setting to take effect.</p>

Group (Tab)	Item	Selections	Remarks
	DNS Domain Name		<p>Up to 32 alphanumeric characters. This setting is not available if DHCP is enabled. The default setting when DHCP is off is null string.</p> <p>The setting when DHCP is changed from on to off is the previous setting when DHCP was on.</p> <p>If this setting is changed, the printer power must be turned off/on for the new setting to take effect.</p>
Interface	I/O Timeout (USB)	15 * 60 300	-
	I/O Timeout (Network)	15 60 * 300	-
	Ethernet speed	Auto Select* 10M half 10M full 100M half 100M full	-
	Fixed USB Port	On/ Off*	
	Wireless Function	Activ*/Inactive	

"\*" indicates the factory default value.

## Network 2

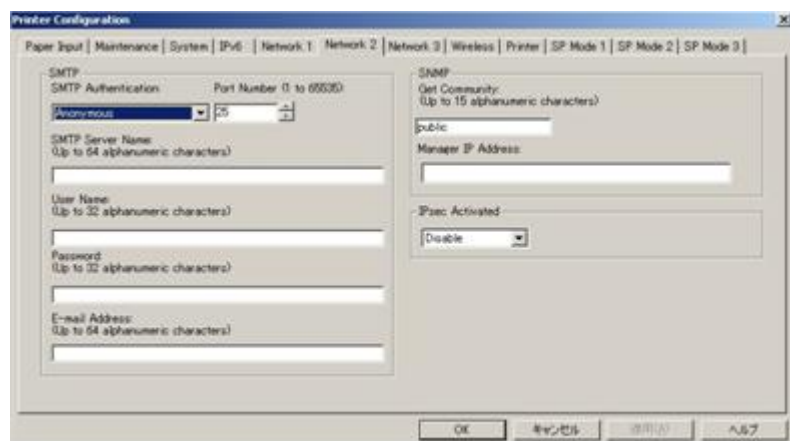

m1549005

Group (Tab)	Item	Selections	Remarks
SMTP	SMTP Authentication	Anonymous*	
		SMTP Authentication	
		POP before SMTP	
	SMTP Server Name	Null string*	Up to 32 alphanumeric characters. The factory default is 'null string'.
	Port Number	25*	1 to 65535 The factory default is 25.
	User Name	Null string*	Up to 32 alphanumeric characters. The factory default is 'null string'.
	Password	Null string*	Up to 32 alphanumeric characters. The factory default is 'null string'. User-input characters and characters read back from the printer will show "" in order to protect the user password.
E-mail Address	Null string*	Up to 64 alphanumeric characters. (address for receiving e-mail) The factory default is 'null string'.	

SNMP	Get Community	public	Up to 15 alphanumeric characters.
	Manager IP Address	0.0.0.0 *	The factory default is 0.0.0.0 If this setting is changed, the printer power must be turned off/on for the new setting to take effect.
IPsec Activated	IPsec Activated	Disable*/Enable	-

"\*" indicates the factory default value.

### Network 3

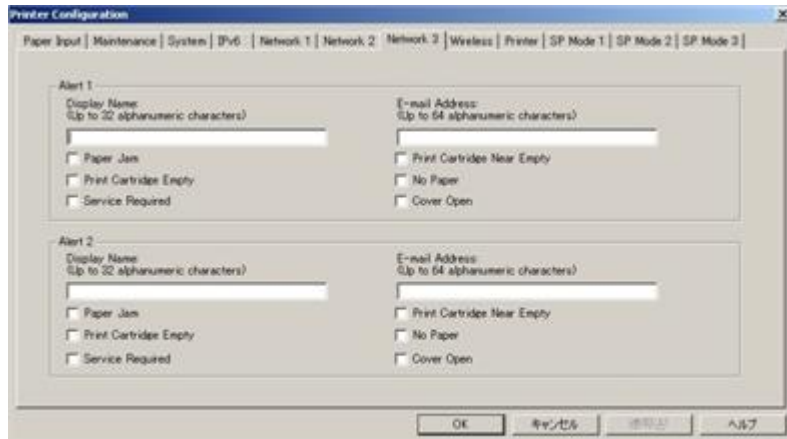

m1549006

Group (Tab)	Item	Selections	Remarks
Alert 1	Display Name	Paper Jam	Up to 32 alphanumeric characters.
		Print Cartridge Empty	
		Service Required	
	E-mail Address	Print Cartridge Near Empty	Up to 64 alphanumeric characters.
		No Paper	
		Cover Open	
Alert 2	Display Name	Paper Jam	Up to 32 alphanumeric characters.
		Print Cartridge Empty	
		Service Required	
	E-mail Address	Print Cartridge Near Empty	Up to 64 alphanumeric characters.
		No Paper	
		Cover Open	

"\*" indicates the factory default value.

**Wireless**

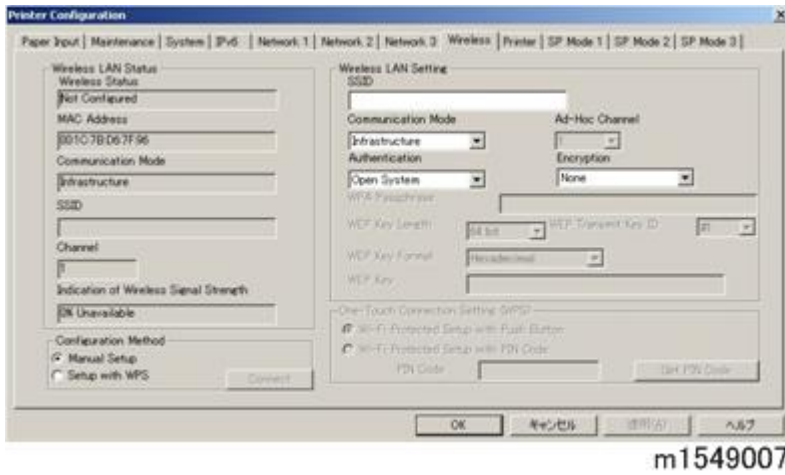

Group (Tab)	Item	Selections	Remarks
Wireless LAN Status	Wireless Status	-	Displays Wireless LAN Status.
	MAC Address	-	
	Communication Mode	-	
	SSID	-	
	Channel	-	
	Indication of Wireless Signal Strength	-	
Configuration Method	-	Manual Setup	-
	-	Setup with WPS	-
Wireless LAN Setting	SSID	-	Input SSID
	Communication Mode	Infrastructure	Selects communication method.
		Ad-Hoc	
	Ad-Hoc Channel	1 to 11	Sets Ad-Hoc Channel.
	Authentication	Open System	Selects authentication method.
Shared Key			

Service Tables

Group (Tab)	Item	Selections	Remarks
		WP A2-PSK	
		Mix Mode WPA/WPA2	
	Encryption	None*	Selects encryption method.
		WEP	
	WPA Passphrase	-	Input WPA passphrase.
	WEP Key Length	64bit*/128bit	Selects WEP key length.
	WEP Transmit Key ID	#1 to #4	
	WEP Key Format	Hexadecimal	
ASCII			
One Touch Connection Setting (WPS)	Wi-Fi Protected Setup with Push Button		
	Wi-Fi Protected Setup with PIN Code		

## Printer

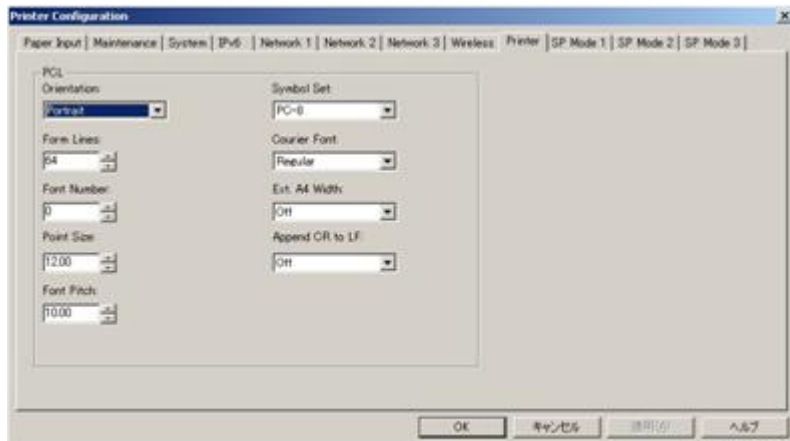

m1549008

Group (Tab)	Item	Selections	Remarks
PCL	Orientation	Portrait *	
		Landscape	
	Form Lines	5 to 128 by 1	If the machine settings are reset to the factory defaults, this value does not change.
	Font Number	0*-89	The factory default value is 0.
	Font Size	4 to 999.75 by 0.25 (12 *)	The factory default value is 12.
Font Pitch	0.44 to 99.99 by 0.01 (10 *)	The factory default value is 10.	

Group (Tab)	Item	Selections	Remarks
PCL	Symbol Set	Roman-8, Roman-9, ISO L1, ISO L2, ISO L5, PC-8* , PC-8 D/N, PC-850, PC-852, PC-858, PC-8 TK, Win L1, Win L2, Win L5, Desktop, PS Text, VN Intl, VN US, MS Publ, Math-8, PS Math, VN Math, Pi Font, Legal, ISO 4, ISO 6, ISO 11, ISO 15, ISO 17, ISO 21, ISO 60, ISO 69, Win 3.0, MC Text, ISO L6, ISO L9, PC-775, PC-1004, Win Balt	
	Courier Font	Regular*	
		Dark	
	Ext. A4 Width	Off*	
		On	
	Append CR to LF	Off *	
		On	

"\*" indicates the factory default value.

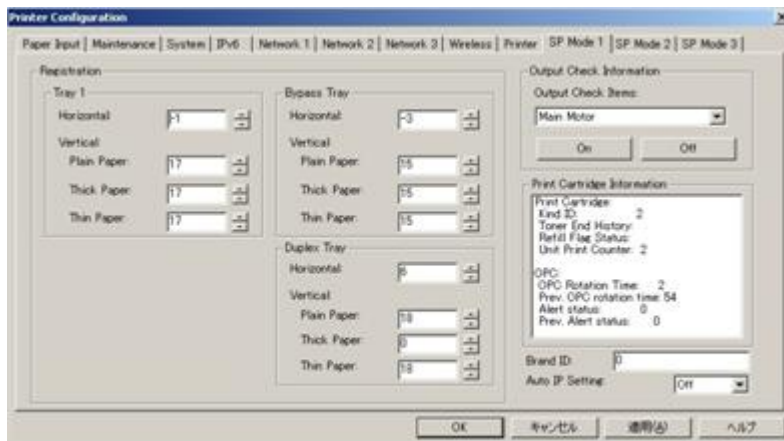
**SP Mode 1**

m1549009

Registration: Tray 1	Horizontal	Adjusts the horizontal registration for tray 1. If the machine settings are reset to the factory defaults, this value does not change. [-40 to 40 / -0 (Default) / 0.1 mm/step]
	Vertical: Plain Paper	Adjusts the vertical registration of plain paper for tray1. If the machine settings are reset to the factory defaults, this value does not change. [-40 to 40 / 0 (Default) / 0.1 mm/step]
	Vertical: Thick Paper	Adjusts the vertical registration of thick paper for tray 1. If the machine settings are reset to the factory defaults, this value does not change. [-40 to 40 / 0 (Default) / 0.1 mm/step]
	Vertical: Thin Paper	Adjusts the vertical registration of thin paper for tray 1. If the machine settings are reset to the factory defaults, this value does not change. [-40 to 40 / 0 (Default) / 0.1 mm/step]
Registration: Bypass Tray	Horizontal	Adjusts the horizontal registration for the bypass tray. If the machine settings are reset to the factory defaults, this value does not change. [-40 to 40 / 0 (Default) / 0.1 mm/step]

	Vertical: Plain Paper	Adjusts the vertical registration of plain paper for the bypass tray. If the machine settings are reset to the factory defaults, this value does not change. [-40 to 40 / 0 (Default) / 0.1 mm/step]
	Vertical: Thick Paper	Adjusts the vertical registration of thick paper for the bypass tray. If the machine settings are reset to the factory defaults, this value does not change. [-40 to 40 / 0 (Default) / 0.1 mm/step]
	Vertical: Thin Paper	Adjusts the vertical registration of thin paper for the bypass tray. If the machine settings are reset to the factory defaults, this value does not change. [-40 to 40 / 0 (Default) / 0.1 mm/step]
Registration: Duplex Tray	Horizontal	Adjusts the horizontal registration the back side in duplex mode. If the machine settings are reset to the factory defaults, this value does not change. [-40 to 40 / 0 (Default) / 0.1 mm/step]
	Vertical: Plain Paper	Adjusts the vertical registration of plain paper for the back side in duplex mode. If the machine settings are reset to the factory defaults, this value does not change. [-40 to 40 / 0 (Default) / 0.1 mm/step]
	Vertical: Thick Paper	Adjusts the vertical registration of thick paper for the back side in duplex mode. If the machine settings are reset to the factory defaults, this value does not change. [-40 to 40 / 0 (Default) / 0.1 mm/step]
	Vertical: Thin Paper	Adjusts the vertical registration of thin paper for the back side in duplex mode. If the machine settings are reset to the factory defaults, this value does not change. [-40 to 40 / 0 (Default) / 0.1 mm/step]

Brand ID	00* – 7F Displays the current brand ID number. Do not change this setting (Designed for Factory Use).	
Auto IP Setting	[On or Off (Default)]	
Output check	Main Motor	Output check (Main Motor)
	Middle Clutch	Output check (Relay Clutch)
	Tray1 Clutch	Output check (Paper Feed Clutch)
	Bypass solenoid	Output check (Bypass solenoid)
	Registration clutch	Output check (Registration Clutch)
	Reverse Clutch	Output check (Reverse Clutch)
	Fan High Speed	Output check (Fan High Speed)
	Fan Low Speed	Output check (Fan Low Speed)
	Erase Lamp	Output check (Quenching Lamp)
	Polygon Motor	Output check (Polygon Motor)
	Duplex Motor Normal	Output check (Duplex Motor Normal)
	Duplex Motor Reverse	Output check (Duplex Motor Reverse)
Print Cartridge Information	Displays Print Cartridge Information. Displays Print cartridge: Kind ID, Toner End History, Refill Flag Status, Unit Print Counter OPC: OPC Rotation Time, Prev. OPC rotation time, Alert Status, Prev. Alert Status	

Service Tables

"\*" indicates the factory default value.

## SP Mode 2

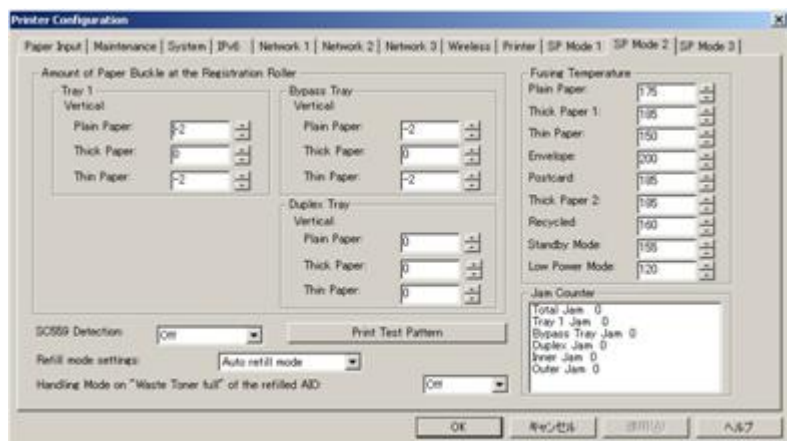

m1549010

Amount of Paper Buckle at the Registration Roller: Tray1	Vertical: Plain Paper	Adjusts the amount of paper buckle at the registration roller for each tray and paper type. [-8 to 8 / -2 (Default) / 1 mm/step]
	Vertical: Thick Paper	Adjusts the amount of paper buckle at the registration roller for each tray and paper type. [-8 to 8 / 0 (Default) / 1 mm/step]
	Vertical: Thin Paper	Adjusts the amount of paper buckle at the registration roller for each tray and paper type. [-8 to 8 / -2 (Default) / 1 mm/step]
Amount of Paper Buckle at the Registration Roller: Bypass Tray	Vertical: Plain Paper	Adjusts the amount of paper buckle at the registration roller for each tray and paper type. [-8 to 8 / -2 (Default) / 1 mm/step]
	Vertical: Thick Paper	Adjusts the amount of paper buckle at the registration roller for each tray and paper type. [-8 to 8 / 0 (Default) / 1 mm/step]
	Vertical: Thin Paper	Adjusts the amount of paper buckle at the registration roller for each tray and paper type. [-8 to 8 / -2 (Default) / 1 mm/step]
Amount of Paper Buckle at the Registration Roller: Duplex Tray	Vertical: Plain Paper	Adjusts the amount of paper buckle at the registration roller for each tray and paper type. [-8 to 8 / 0 (Default) / 1 mm/step]
	Vertical: Thick Paper	
	Vertical: Thin Paper	

Fusing Temperature	Plain Paper	Adjusts the fusing temperature for plain paper. [150 to 190 / 175 (Default) / 5°C/step]
	Thick Paper 1	Adjusts the fusing temperature for thick 1 paper. [160 to 200 / 185 (Default) / 5°C /step]
	Thin Paper	Adjusts the fusing temperature for thin paper. [140 to 165 / 150 (Default) / 5°C/step]
	Envelope	Adjusts the fusing temperature for envelope. [170 to 200 / 200 (Default) / 5°C/step]
	Postcard	Adjusts the fusing temperature for postcard. [160 to 200 / 185 (Default) / 5°C/step]
	Thick Paper 2	Adjusts the fusing temperature for thick 2 paper. [160 to 200 / 185 (Default) / 5°C/step]
	Recycled	Adjusts the fusing temperature for recycled paper. [150 to 180 / 160 (Default) / 5°C/step]
	Standby Mode	Adjusts the fusing temperature in the standby mode. [120 to 175 / 155 (Default) / 1°C/step]
	Low Power Mode	Adjusts the fusing temperature in the low power mode. [80 to 135 / 120 (Default) / 5°C/step]
Jam Counter	Displays Jam Counter for each location. Total Jam, Tray1 Jam, Bypass Tray Jam, Duplex Jam, Inner Jam, Outer Jam	
Print Test Pattern	Prints the test pattern.	
SC559 Detection	[On or Off (Default)]	
Refill Mode Setting	Auto refill mode	Do not change this setting (Designed for Factory Use).

	Pure refill mode	Do not change this setting (Designed for Factory Use).
Handling Mode on "Waste Toner full" of the refilled AIO	Sets the machine operation at "waste toner full" of the refilled AIO. [On or Off (Default)]	

"\*\*" indicates the factory default value.

### SP Mode 3

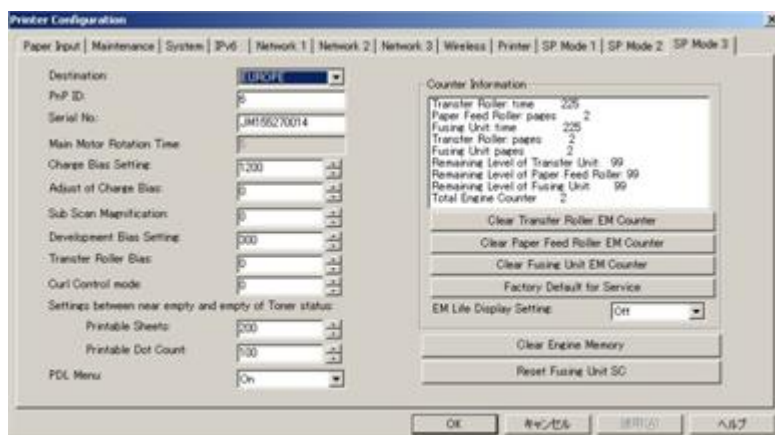

m1549011

Destination	Sets the destination and updates the engine setting. Do not change this setting (Designed for Factory Use). JPN/ NA/ EU / ASIA/ China/ TAIWAN
PnP ID	Do not change this setting (Designed for Factory Use).
Serial No	Do not change this setting (Designed for Factory Use).
Main Motor Rotation Time	Displays the main motor rotation time.
Charge Bias	Adjusts the charge bias. [1100 to 1300 / 1200 / 25 /step]
Adjust of Charge Bias	Charge bias correction for dirty background 0: OFF (Default) 1: ON 2 to 255: not available [0 to 255 / 0 / 1 /step]

Sub Scan Magnification	Adjusts the sub scan magnification. [-8 to 8 / 0 / 1 /step]	
Development Bias Setting	Adjusts the developer bias. [270 to 330 / 300 / 15 /step]	
Transfer Roller Bias	Adjusts the transfer roller bias. [-6 to 6 / 0 / 1 /step]	
Curl Control mode	Corrects the face curl of paper. 0: OFF (28ppm) 1: Sets the engine speed at 14ppm after printing 1 minute. 2: Sets the engine speed at 14ppm. 3 to 255: not available [0 to 255 / 0 / 1 /step]	
Settings between near empty and empty of Toner status	Printable Sheets	Adjusts the printable sheets between "toner near end" to "toner end". [0 to 255 / 200 / 1 sheet/step]
	Printable Dot Count	Adjusts the printable dot count between "toner near end" to "toner end". [0 to 255 / 100 / 1 dot/step]
PDL Menu	ON = "PDL Settings" is shown (Default) OFF = "PDL Settings" is hidden	
Counter Information	Display the counter information.	
Clear Transfer Roller EM Counter	Clears the EM counter of the transfer roller.	
Clear Paper Feed Roller EM Counter	Clears the EM counter of the paper feed roller.	
Clear Fusing Unit EM Counter	Clears the EM counter of the fusing unit.	
Factory Default for Service	Resets all the settings to factory default.  Note <ul style="list-style-type: none"> <li>Clears/ resets the contents of the controller memory (all data programmed by the user, log data application counters) to factory default.</li> </ul> After executing, initial setup menu starts after power-on.	

EM Life Display	Sets the display of alert when each EM parts yield of this machine is reached. [On (Default) or Off]
Clear Engine Memory	Resets the engine settings stored in the EEPROM to factory default.
Reset Fusing Unit SC	This button is for resetting an SC related with the fusing errors.

## 5.2 REPORTS

### 5.2.1 CONFIGURATION PAGE

The configuration page has information about the machine's status. Print this sheet as shown below. Check the configuration page when doing machine maintenance.

#### *To Print the Configuration Page*

1. Start the SOM utility.
2. Click the "User Tools" tab.
3. Select "Configuration Page" in the "List/ Test Print".
4. Click "Print".

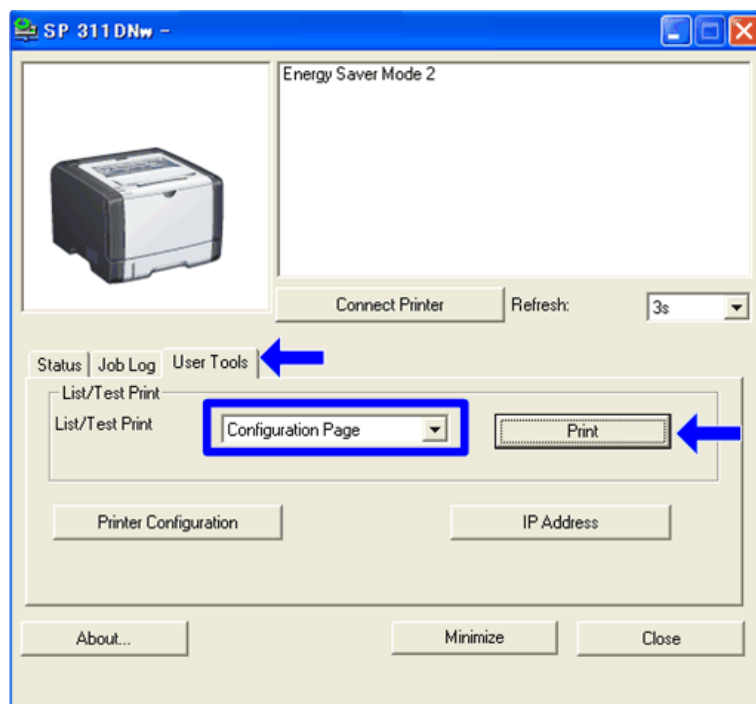

m1542109

5. The configuration page is printed.
  - Configuration page example

Configuration Page (1/2)		RICOH SP 311DNw	
<b>System Reference</b>			
Machine ID			
Total Memory	128MB		
Firmware Version	Bootloader[V0.20], Firmware[v0.68/M1545051B], Engine[0.21]		
Printer Language	PCL 5e[v0.68], PCL XL[v0.68]		
Print Cartridge	[Progress Bar]		
Transfer Roller	[Progress Bar]		
Paper Feed Roller	[Progress Bar]		
Fusing Unit	[Progress Bar]		
<b>Paper Input</b>			
Tray Priority	Tray 1		
Bypass Tray Priority	Machine Setting(s)		
Bypass Tray	A4	Plain Paper (65-99g/m2)	
Tray 1	A4	Plain Paper (65-99g/m2)	
Size Mismatch Detection	Off		
<b>Maintenance</b>			
Registration			
Horizontal: Tray 1	0	Vertical: Tray 1	0
Horizontal: Bypass Tray	0	Vertical: Bypass Tray	0
Horizontal: Duplex: Back Side	0	Vertical: Duplex: Back Side	0
<b>System</b>			
Auto Continue	Off	Copies	1
Sub Paper Size	Off	Duplex	Off
Blank Page Print	On	Energy Saver Mode 1	Off
Energy Saver Mode 2	On	Energy Saver Mode 2 Timer	1 minute
Default Paper Size	A4	Print Error Report	Off
Auto E-mail Notification	Off	Low Humidity Mode	Off
<b>PCL Menu</b>			
Orientation	Portrait	Form Lines	64
Font Number	0	Point Size	12.00
Font Pitch	10.00	Symbol Set	PC-8
Courier Font	Regular	Extend A4 Width	Off
Append CR to LF	Off	Resolution	600 x 600 dpi
<b>Host Interface</b>			
Timeout: USB	60 seconds	Timeout: Network	60 seconds
DHCP	Active	IP Address	133.139.166.67
Subnet Mask	255.255.255.0	Gateway Address	133.139.166.1
Ethernet	Auto Select	USB Setting	Auto Select
Fixed USB Port	Off	IPsec	Inactive
<b>Interface Information</b>			
MAC Address	00-26-73-52-ca-2f	Host Name	311DNw-52CA2F
<b>Counter List</b>			
Total Counter	25	Duplex Counter	0
<b>Paper Misfeed Counter</b>			
Total Counter	0	Paper Misfeed: Duplex Unit	0
Paper Misfeed: Standard Tray	0	Internal Misfeed	0
Paper Misfeed: Tray 1	0	Paper Misfeed: Bypass Tray	0
<b>Error Log</b>			

m1542097

## Total Counter

### Total Counter:

The total counter incremented by the "main board" each time the board issues a print command to the engine.

The value is calculated as follows:

Total counter = Printer counter + Reports print

### Application Counters:

Application counters exist for each individual primary machine function, and are incremented by the "main board" each time the board issues a print request for the function in question.



- The application counters is 0 If you select "Factory Default for Service" in the SP mode 3.

## 5.2.2 OTHER TYPES OF REPORTS

You can also check other reports than reports of configuration page with "List/Test Print" in the SOM or Web image monitor.

- Test Page
- PCL Config./Font Page  
Prints the current configuration and installed PCL font list.
- Maintenance Page (Web image monitor only)  
Prints the maintenance status.

## 5.2.3 TEST PAGE

When you check an image problem or other problems, it might be necessary to print a test page. Follow the test page print procedure below to print a test page.

### *To Print the Test Page*

1. Start the SOM utility.
2. Click the "User Tools" tab.
3. Select "Test Page" in the "List/ Test Print".
4. Click "Print".

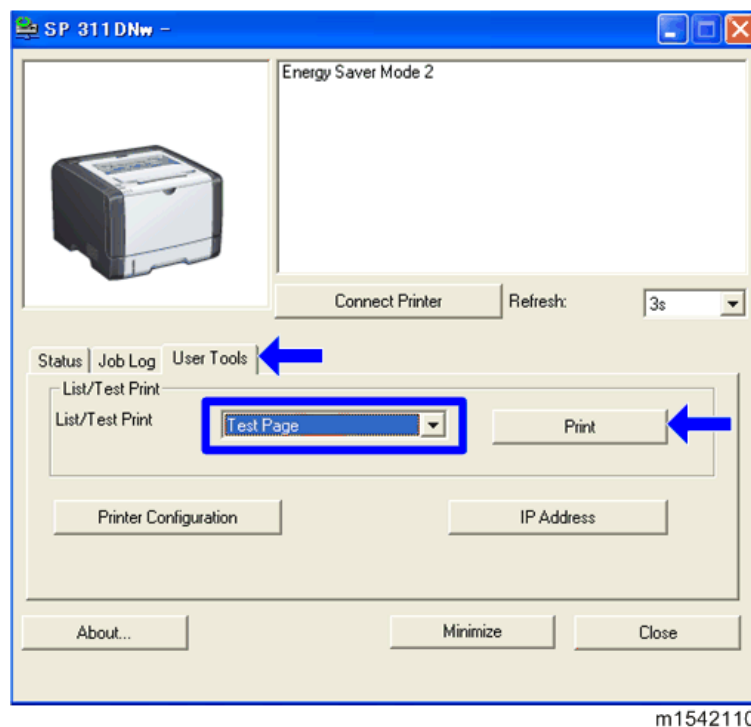

5. The test page is printed.
  - Test page sample

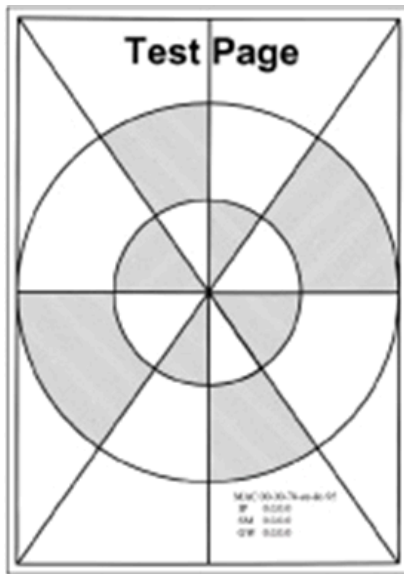

m118t100

## 5.2.4 TEST PATTERN PRINTING

Follow the test pattern print procedure below to print a test pattern.

### *To Print the Test Pattern*

1. Start the SOM utility.
2. Click the "User Tools" tab.
3. Click "Printer Configuration".

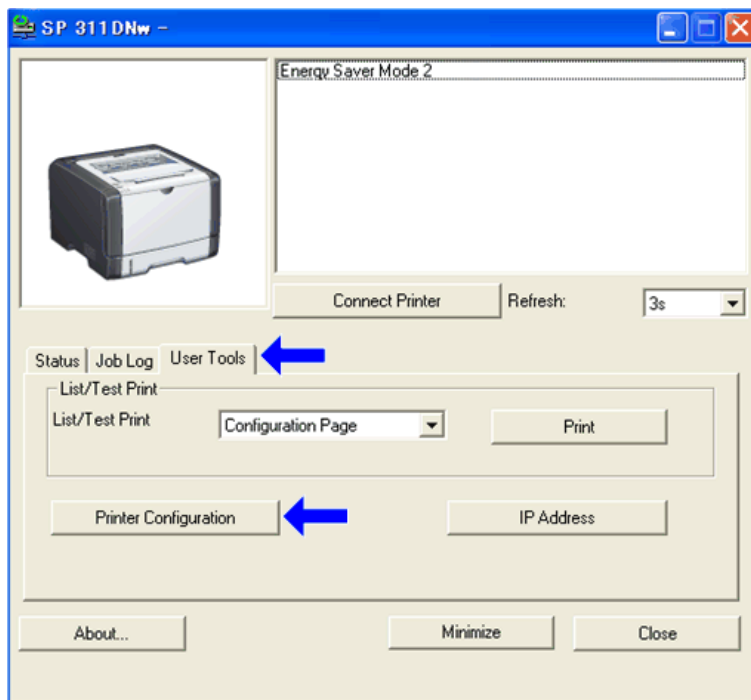

m1542108

4. The "Access Code" entry dialog appears.
5. Input the access code (for customer engineers).and then Click "OK".

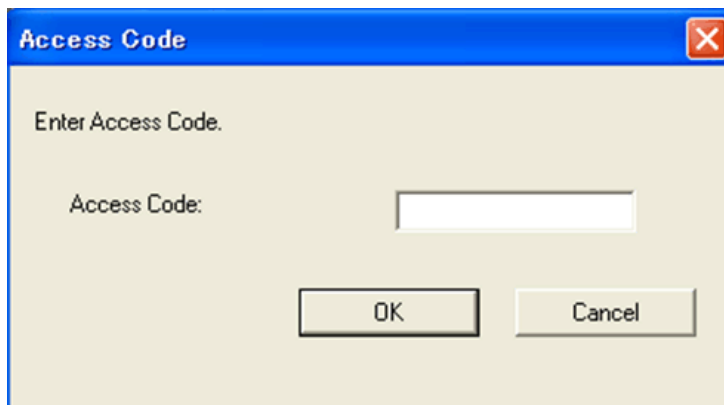

m1542111

6. Select the "SP Mode 2" tab.
7. Click "Print Test Pattern".

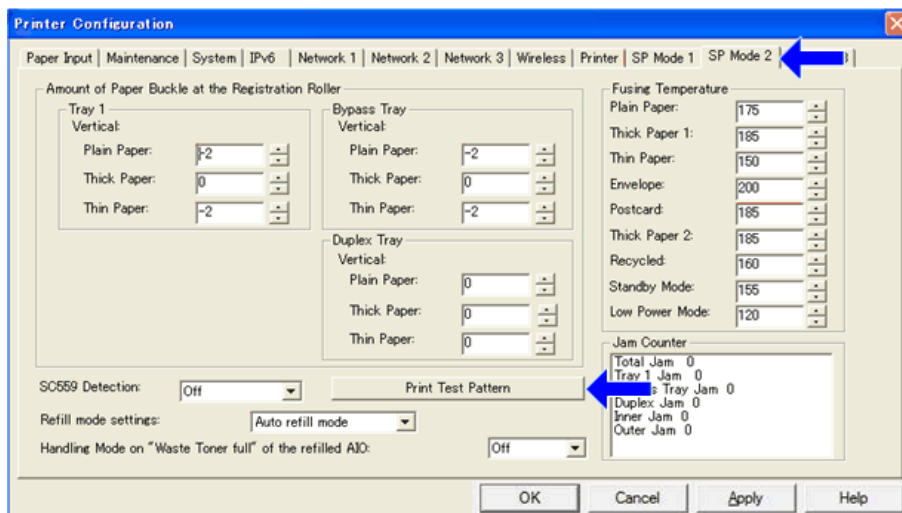

m1542112

8. The following three test pattern pages (Checker flag/ Grid pattern/ Trimming pattern) are printed.

- Test pattern samples

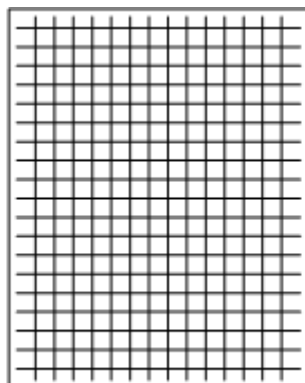
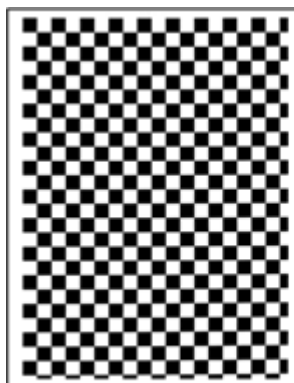

m016t502

Service Tables

## 5.3 UPDATING THE FIRMWARE



- Never turn the machine's main power off while the firmware is being updated, as this could damage the main board.

### 5.3.1 CHECKING THE MACHINE FIRMWARE VERSION

To update the firmware for this machine, you need the most recent version of the firmware (firmware file downloadable from the Internet).

1. Start the SOM utility.
2. Click the "User Tools" tab.
3. Select "Configuration Page" in the "List/ Test Print".
4. Click "Print" to print the "Configuration Page", which shows the "Firmware Version".

### 5.3.2 UPDATING THE MAIN FIRMWARE

Using the following procedure to update the main firmware, be sure to print the configuration page both before and after the update. Comparing pre- and post-update configuration pages allows you to check whether or not the update was successful.

Follow the procedure carefully, and note that it will vary in parts depending on which version of the firmware is currently installed.

#### ***Procedure***

When updating firmware, always disconnect any other cable(s) than the one being used for the update operation.

(When updating firmware via USB cable, first disconnect any network and phone line cables, and when updating firmware via LAN cable, first disconnect any USB and phone line cables.)

1. Prepare:
  - Computer: Windows XP/Vista/7/8, Windows Server 2003/2003 R2, 2008/2008 R2, 2012
  - USB cable or LAN (Local Area Network) cable
2. Download the firmware files to your computer.
  - FwUpdateTool.exe (User Mode execute file)
  - Setting.ini (Parameter setting)
  - xxx.brn (Main Firmware)
3. Make a folder on a local drive of your computer and save the files there.
4. Connect a computer and the machine through a network or directly by USB.
5. Click the "FWUpdateTool.exe" file to execute the updating program.
6. Check the information, and then click [OK].
7. For a USB connection, click "F/W Update (USB)" [A]. For a network connection, enter the

machine's IP address in "Machine IP" [B], and then click "F/W Update (NET)" [C].

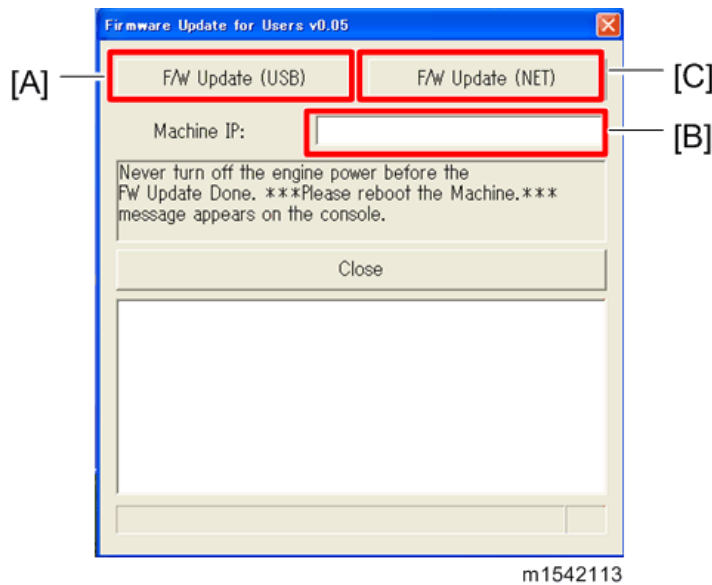

8. The following message appears on the screen:  
"Firmware is Updating ..." and the Alert LED (red) on the printer starts blinking. (The Ready LED remains lit.)

### CAUTION

- Do not turn the main power off from this point until the update procedure is completed.
9. Wait until "FW Update Done. \*\*\*Please reboot the Machine. \*\*\*" appears in the firmware update tool window. The Ready LED (green) on the printer starts blinking. (The Alert LED is still blinking.)
10. Turn off the power of the machine, and then turn it back on.
11. Print a configuration page to check the machine's firmware version.

## 5.3.3 UPDATING THE BOOT LOADER FIRMWARE

This is also listed on the configuration page, but this firmware is not updated in the field.

## 5.3.4 UPDATING FAILURE

If the firmware update is not successful, the update process is suspended and an error message should display on the FW Update Tool screen. The Alert LED (red) on the printer starts lighting. (The Ready LED remains lit.) If this happens, DO NOT turn off the machine; you must execute the update procedure again (unless the error message "Downloaded file is broken! Do NOT use print, scan, fax and copy function at the same time." is displayed).

If power is turned off accidentally during a firmware update, the firmware will not be correctly updated, and the machine may not start up normally. If the machine does not start up normally, the Main firmware will need to be updated again.

### 5.3.5 FW UPDATE TOOL MESSAGES

#### *FW Update Tool Messages: Information*

##### Message for USB update

Messages	Comment	Action
USB Upload : End of data	Send F/W file to Printer successfully. (Transmission Time: <30 sec)	Please reboot Printer after panel shows reboot message.
USB Upload : FAIL	Cannot open USB printer driver while F/W file is transmitted.	Check USB cable connection. Check whether the USB Print Driver is available. Check whether the printer is available.
	F/W file transmission cannot be completed. (Transmission will be canceled if timeout.)	Check USB cable connection. Check whether the USB Print Driver is available. Check whether the printer is available.
Can't open ROM file. Please check ROM file.	F/W file does not exist.	Check the download file name in setting.ini. "ImageFile="
New Version: Update FW	Main FW is transmitting	Nothing to do; please wait
Firmware is Updating...	Main FW is updating	Nothing to do; please wait
FW Update Done. *** Please reboot the Machine.***	F/W update is completed.	Please reboot the machine.

##### Message for Network update

Messages	Comment	Action
Connecting...	Connect to Printer.	Please wait a moment.
Net Upload : End of data	Update F/W successfully. (Transmission Time: <30 sec)	Please reboot printer after panel shows reboot message.
Net Upload : FAIL	Can not open FTP port of Printer before F/W file is transmitted. (Transmission will be canceled if timeout.)	Check network cable connection. Check whether the printer is available. Check the printer and PC IP address setting. Check the PC firewall setting about FTP.
	F/W file transmission can not be completed. (Transmission will be canceled if timeout.)	(1) Check network cable connection. (2) Check whether the printer is available.
Can't open ROM file. Please check ROM file.	F/W file does not exist.	Check the download file name in setting.ini. "ImageFile="
		Check that the download file and f/w update tool are in the same folder.
New Version: Update FW	Main FW is transmitting	Nothing to do; please wait
Firmware is Updating...	Main FW is updating	Nothing to do; please wait
FW Update Done. *** Please reboot the Machine.***	F/W update is completed.	Please reboot the machine.

***FW Update Tool Messages: Error***

**Message for USB update**

Messages	Comment	Action
Machine is not ready.	Can not get Printer status form USB status channel before F/W file is transmitted.	Check USB cable connection. Check whether the USB Print Driver is available. Do not update F/W when the printer is still powering up.
Wrong Model.	F/W file is not matched for current machine.	Please check the version of the F/W file and whether it is suitable for the printer.
Machine is busy.	F/W update is running. Other Printer functions are running.	Please wait until F/W update is completed. Please wait until other printer functions are completed.
FW Update Done. *** Please reboot the Machine.***	F/W update is completed.	Please reboot the machine.
Machine loses communication. ***Please check FW Update Done. Then reboot the Machine.***	F/W file has transmitted. Polling F/W update progress fail.	Do not reboot engine until Engine Panel display "Firmware Update Done. Please reboot". Then reboot engine.
Downloaded file is broken! Do NOT use print, scan, fax and copy function at the same time.	F/W checks the downloaded file. And get wrong checksum. So stop modifying F/W.	Check the downloaded file is not broken. Do not use printer functions when updating firmware.

**Message for Network update**

Messages	Comment	Action
Machine is not ready.	Cannot get Printer status form Network status channel before F/W file is transmitted.	Check PC network settings and IP address. Check printer network settings and IP address. Do not update F/W when printer is still powering up.
Wrong Model.	F/W file is not matched for current machine.	Please check the version of the F/W file and whether it is suitable for printer.
Machine is busy.	F/W update is running. Other Printer functions are running.	Please wait until F/W update is completed. Please wait until other printer functions are completed.
FW Update Done. *** Please reboot the Machine.***	F/W update is completed.	Please reboot the machine.
Machine loses communication. ***Please check FW Update Done. Then reboot the Machine.***	F/W file has transmitted. Polling F/W update progress fail.	Do not reboot engine till Engine Panel display "Firmware Update Done. Please reboot". Then reboot the engine.
Downloaded file is broken! Do NOT use print, scan, fax and copy function at the same time.	F/W checks the downloaded file. And get wrong checksum. So stop modifying F/W.	Check the downloaded file is not broken. Do not use printer functions when updating firmware.



# TROUBLESHOOTING

REVISION HISTORY		
Page	Date	Added/Updated/New
		None



---

## 6. TROUBLESHOOTING

### 6.1 SELF-DIAGNOSTIC MODE

#### 6.1.1 SELF-DIAGNOSTIC MODE AT POWER ON

As soon as the main machine is powered on, the controller waits for the initial settings of the copy engine to take effect and then starts an independent self-diagnostic test program.

The self-diagnostic test checks the CPU, memory, and so on. An SC code is displayed if the self-diagnostic program detects any malfunction or abnormal condition. If it is an error with which the machine can start, the machine records it in the System Error Log.

## 6.2 SERVICE CALL

See "Appendices" for the "Error Message".

### 6.2.1 SUMMARY

This machine issues an SC (Service Call) code if an error occurs with the machine. The error code can be seen with the SOM.

Make sure that you understand the following points;

1. All SCs are logged.
2. At first, always turn the main switch off and on if an SC code is displayed.
3. First, disconnect then reconnect the connectors before replacing the PCBs (if the problem concerns electrical circuit boards).
4. First, check the mechanical load before replacing motors or sensors (if the problem concerns a locked motor).

#### ***Fusing related SCs***

To prevent damage to the machine, the main machine cannot be operated until the fusing related SC has been reset by a service representative.

- Enter "SP Mode 3" in the SOM.

Click "OK" in "Reset Fusing Unit SC" with "SP Mode 3", and then turn the main power switch off and on.

## 6.2.2 ENGINE SC

### SC 2xx (Laser Optics Error)

202	Polygon motor on timeout error
	<p>The polygon mirror motor does not reach the targeted operating speed within 10 sec. after turning.</p> <ul style="list-style-type: none"> <li>● Polygon motor/driver board harness loose or disconnected</li> <li>● Polygon motor/driver board defective</li> <li>● Laser optics unit defective</li> </ul> <ol style="list-style-type: none"> <li>1. Turn the machine main power off/on.</li> <li>2. Replace the interface harness of the laser optics unit.</li> </ol> <p>Replace the laser optics unit.</p>
203	Polygon motor off timeout error
	<p>The polygon mirror motor does not leave the READY status within 20 sec. after the polygon mirror motor switched off.</p> <ul style="list-style-type: none"> <li>● Polygon motor/driver board harness loose or disconnected</li> <li>● Polygon motor/driver board defective</li> <li>● Laser optics unit defective</li> </ul> <ol style="list-style-type: none"> <li>1. Turn the machine main power off/on.</li> <li>2. Replace the interface harness of the laser optics unit.</li> </ol> <p>Replace the laser optics unit.</p>
204	Polygon motor lock signal error
	<p>The signal remains HIGH for 200 ms (or 4times in 50msec polling) while the polygon mirror motor is rotating.</p> <ul style="list-style-type: none"> <li>▪ Polygon motor/driver board harness loose or disconnected</li> <li>▪ Polygon motor/driver board defective</li> <li>▪ Laser optics unit defective</li> </ul> <ol style="list-style-type: none"> <li>1. Turn the machine main power off/on.</li> <li>2. Replace the interface harness of the laser optics unit.</li> <li>3. Replace the laser optics unit.</li> </ol>

220	Beam Synchronize error
	The laser synchronizing detection signal for LD is not output within 400msec after the LD unit has turned on.
	<ul style="list-style-type: none"> <li>▪ Disconnected cable from the laser synchronizing detection unit or defective connection</li> <li>▪ Defective laser synchronizing detector</li> <li>▪ Defective LD</li> <li>▪ Defective Main board</li> </ul> <ol style="list-style-type: none"> <li>1. Turn the machine main power off/on</li> <li>2. Check the connectors.</li> <li>3. Replace the laser optics unit.</li> <li>4. Replace the Main board.</li> </ol>
268	Laser Scanning Unit thermistor error
	At power on, the temperature sensor in the optics unit detected a temperature lower than -30°C for more than 4 sec. -or- It detected a temperature higher than 105°C for more than 1sec.
	<ul style="list-style-type: none"> <li>▪ Thermistor disconnected (causes extremely low temperature reading)</li> <li>▪ Thermistor damaged and short circuited (causes extremely high temperature reading)</li> </ul> <ol style="list-style-type: none"> <li>1. Turn the machine's main power off, and then on.</li> <li>2. Replace the thermistor.</li> </ol>

**SC 4xx (Image Transfer and Transfer Error)**

491	Bias leak
	<p>Bias leaked at the drum charge, development charge, or transfer charge. PWM signals are sampled at 20 msec. intervals. This SC is issued if 10 PWM samplings within 200 msec. are abnormal.</p> <ul style="list-style-type: none"> <li>● HVPS harness loose, broken, defective</li> <li>● HVPS board defective</li> <li>● AIO terminal defective</li> </ul>
	<ul style="list-style-type: none"> <li>● Cycle the machine off/on</li> <li>● Check all the harness connections of the HVPS</li> <li>● Check spring-loaded AIO terminal installation behind the HVPS</li> <li>● Replace HVPS</li> </ul>

**SC 5xx (Motor and Fusing Error)**

500	Main motor error
	The machine does not detect a main motor lock signal within 2sec after the main motor started to rotate. -or- The machine does not release a main motor lock signal within 2sec after the main motor switched off. -or- The machine detects a main motor lock signal every 100ms for seven times consecutively, after the main motor started to rotate stably.
	<ul style="list-style-type: none"> <li>▪ Overload of</li> <li>▪ Torque load overload</li> <li>▪ Defective main motor</li> <li>▪ Disconnect or defective motor harness</li> </ul> <ol style="list-style-type: none"> <li>1. Turn the machine's main power off, and then on.</li> <li>2. Check or replace the main motor if the torque load is normal.</li> <li>3. Replace the motor harness.</li> </ol>
530	Exhaust fan Error
	The FAN lock signal – High for 10 seconds, after the fan motor started to rotate.
	<ul style="list-style-type: none"> <li>▪ Disconnected or defective fan motor harness.</li> </ul> <ol style="list-style-type: none"> <li>1. Turn the machine's main power off, and then on.</li> </ol>
541	Fuser thermistor error
	The thermistor output is less than 0°C for 5 seconds after the fusing lamp turns ON.
	<ul style="list-style-type: none"> <li>▪ Disconnected or defective thermistor</li> <li>▪ Disconnected or defective fusing lamp</li> </ul> <ol style="list-style-type: none"> <li>1. Check the harness connection of the thermistor.</li> <li>2. Replace the fusing unit.</li> </ol> <p><b>★ Important</b></p> <ul style="list-style-type: none"> <li>▪ Execute "Reset Fusing Unit SC" to recover the machine after completing the recovery procedure. Otherwise, the machine continues to issue this SC code and cannot be operated.</li> </ul>

	<p>Fuser reload error</p> <p>This SC occurs, if any of the following conditions are met:</p> <p><b><u>In a 100V power supply environment:</u></b></p> <ol style="list-style-type: none"> <li>1. The fusing temperature increased 6 degrees C or less for 5 times consecutively within 1.5 seconds.</li> <li>2. The fusing temperature did not reach 45 degrees C within 11 seconds after the fusing lamp turned ON.</li> <li>3. The fusing temperature did not reach the reload temperature within 35 seconds in a normal/high temperature operational environment, or 55 seconds in a low temperature operational environment.</li> </ol> <p><b><u>In a 200V power supply environment:</u></b></p> <ol style="list-style-type: none"> <li>1. The fusing temperature increased 9 degrees C or less for 5 times consecutively within 1.5 seconds.</li> <li>2. The fusing temperature did not reach 45 degrees C within 11 seconds after the fusing lamp turned ON.</li> <li>3. The fusing temperature did not reach the reload temperature within 35 seconds in a normal/high temperature operational environment, or 50 seconds in a low temperature operational environment.</li> </ol> <ul style="list-style-type: none"> <li>● Disconnected or defective thermistor</li> <li>● Incorrect input power supply detected at the main power socket</li> <li>● Heater defective or thermostat circuit disconnected</li> </ul> <p><b><u>Important</u></b></p> <p>To resolve the SC, perform "Reset Fusing Unit SC" after solving the problem, or the system will continue to display the SC.</p>
543	<p>High temperature error (Soft)</p> <ul style="list-style-type: none"> <li>▪ The detected temperature stays at 235°C for 1 second, and this consecutively occurs 10 times.</li> </ul> <ul style="list-style-type: none"> <li>▪ Defective Main board</li> <li>▪ Defective PSU</li> </ul> <ol style="list-style-type: none"> <li>1. Replace the Main board</li> <li>2. Replace the PSU</li> </ol> <p><b>★ Important</b></p> <ul style="list-style-type: none"> <li>▪ <b>Execute "Reset Fusing Unit SC" to recover the machine after completing the recovery procedure. Otherwise, the machine continues to issue this SC code and cannot be operated.</b></li> </ul>

544	High temperature error (hard)
	<ul style="list-style-type: none"> <li>▪ During stand-by mode or a print job, the detected heating roller temperature reaches 250°C.</li> </ul>
	<ul style="list-style-type: none"> <li>▪ Defective Main board</li> <li>▪ Defective PSU</li> </ul> <ol style="list-style-type: none"> <li>1. Replace the Main board</li> <li>2. Replace the PSU</li> </ol> <p><b>★ Important</b></p> <ul style="list-style-type: none"> <li>▪ Execute "Reset Fusing Unit SC" to recover the machine after completing the recovery procedure. Otherwise, the machine continues to issue this SC code and cannot be operated.</li> </ul>
545	Fuser full heater error
	The fuser full heater remained ON at full capacity for more than 9 s after the fusing temperature attains reload temperature.
	<ul style="list-style-type: none"> <li>▪ Deformed thermistor</li> <li>▪ Thermistor not in the correct position</li> <li>▪ Defective fusing lamp</li> </ul> <ol style="list-style-type: none"> <li>1. Replace the fusing unit.</li> <li>2. Replace the fusing lamp.</li> </ol> <p><b>★ Important</b></p> <ul style="list-style-type: none"> <li>▪ Execute "Reset Fusing Unit SC" to recover the machine after completing the recovery procedure. Otherwise, the machine continues to issue this SC code and cannot be operated.</li> </ul>
547	Zero cross error
	<ul style="list-style-type: none"> <li>● The zero cross signal is detected three times even though the fusing lamp relay is off when turning on the main power.</li> <li>● The zero cross signal is not detected for 3 seconds even though the fusing lamp relay is on after turning on the main power or closing the front door.</li> <li>● The detection error occurs twice or more in 10 zero cross signal detections. This error is defined when the detected zero cross signal is less than 45.</li> <li>▪ The zero cross signal is not detected for 3 seconds while the main power remains ON.</li> </ul>

	<ul style="list-style-type: none"> <li>● Defective fusing relay</li> <li>● Defective fusing relay circuit</li> <li>● Open +24V fuse on the PSU</li> <li>● Unstable power supply</li> </ul> <ol style="list-style-type: none"> <li>1. Check the power supply source</li> <li>2. Replace the +24V fuse on the PSU</li> <li>3. Replace the PSU</li> </ol> <ol style="list-style-type: none"> <li>1. <i>Turn the machine main power off/on</i></li> </ol>
560	<p>Fuser reload error due to low voltage</p> <p><b><u>In a 100V power supply environment:</u></b></p> <ol style="list-style-type: none"> <li>1. The fusing temperature increased 6 degrees C or less for 5 times consecutively within 1.5 seconds.</li> <li>2. The fusing temperature did not reach 45 degrees C within 11 seconds after the fusing lamp turned ON.</li> <li>3. The fusing temperature did not reach the reload temperature within 35 seconds in a normal/high temperature operational environment, or 55 seconds in a low temperature operational environment.</li> <li>4. The fusing temperature was 100 degrees C or more below the target temperature for 5.2 seconds during the waiting and printing statuses.</li> </ol> <p><b><u>In a 200V power supply environment:</u></b></p> <ol style="list-style-type: none"> <li>1. The fusing temperature increased 9 degrees C or less for 5 times consecutively within 1.5 seconds.</li> <li>2. The fusing temperature did not reach 45 degrees C within 14 seconds after the fusing lamp turned ON.</li> <li>3. The fusing temperature did not reach the reload temperature within 45 seconds in a normal/high temperature operational environment, or 65 seconds in a low temperature operational environment.</li> <li>4. The fusing temperature was 100 degrees C or more below the target temperature for 5.2 seconds during the waiting and printing statuses.</li> </ol> <ul style="list-style-type: none"> <li>● Disconnected or defective thermistor</li> <li>● Incorrect input power detected at the main power socket</li> <li>● Heater defective or thermostat circuit disconnected</li> </ul> <ol style="list-style-type: none"> <li>1. Turn the machine main power off/on.</li> <li>2. Replace the interface harness of the fuser unit.</li> <li>3. Replace the fuser unit.</li> </ol>

559	Fuser 3times jam error
	<p>The paper jam counter for the fusing unit reaches 3. The paper jam counter is cleared if the paper is fed correctly.</p> <p>This SC is activated only when this function is enabled with "Eng. Maintenance" (default "OFF").</p>
	<ul style="list-style-type: none"> <li>▪ Defective fusing unit</li> <li>▪ Defective fusing control</li> </ul> <ol style="list-style-type: none"> <li>1. Clear this SC to send a command after a jam removal.</li> <li>2. Turn off this function after a jam removal.</li> </ol> <p><b>★ Important</b></p> <ul style="list-style-type: none"> <li>▪ <b>Execute "Reset Fusing Unit SC" to recover the machine after completing the recovery procedure. Otherwise, the machine continues to issue this SC code and cannot be operated.</b></li> </ul>

### SC 6xx (Communication and other Errors)

688	The engine does not receive the image transfer command from the controller.
	<p>This SC occurs, if the following condition is met:</p> <ul style="list-style-type: none"> <li>● The engine does not receive the image transfer command from the controller within the prescribed time (20sec) after the registration roller reaches the standby position.</li> </ul>
	<ul style="list-style-type: none"> <li>● Defective controller board</li> <li>● Communication error between the engine and controller</li> </ul> <p>Turn the machine main power off/on</p>

## 6.3 JAM DETECTION

### 6.3.1 JAM SENSOR LAYOUT

There are the sensors of the jam detection as shown below.

#### *Paper Jam*

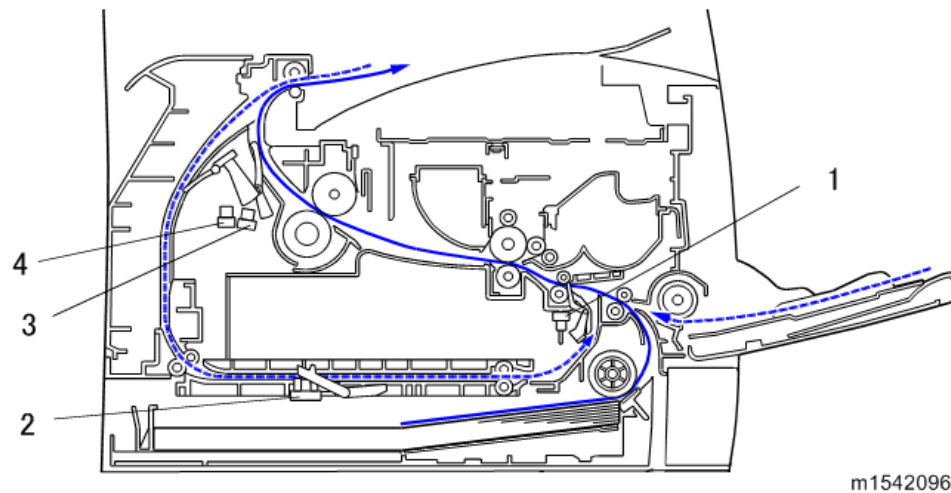

1. Registration Sensor
2. Inverter Sensor
3. Paper Exit Sensor
4. Relay Sensor

### 6.3.2 JAM MESSAGE LIST

Here is a list of common jam messages, a description of the causes.

See the drawing shown above to check the sensor location.

### **Paper Jam**

Related to jam code

Jam message	Cause	Sensor
Misfeed: PprTray	Paper does not reach registration sensor (bypass tray)	Registration sensor [1]
Misfeed: Tray 1	Paper does not reach registration sensor (tray 1)	Registration sensor [1]
Misfd: Dupl Unit	Paper does not reach registration sensor (duplex feed tray)	Registration sensor [1]
	Paper does not reach duplex entry sensor	Relay sensor [5]
	Paper does not reach duplex exit sensor	Inverter sensor [3]
Internal Misfeed	Paper stayed on registration sensor	Registration sensor [1]
	Paper does not reach exit sensor	Paper exit sensor [4]
Misfd: Stnd Tray	Paper stayed on exit sensor	Paper exit sensor [4]

Related to jam at initialization

Jam message	Cause
Internal Misfeed	Registration sensor [1]
Misfd: Stnd Tray	Paper exit sensor [4]
Misfd: Dupl Unit	Relay sensor [5]
	Inverter sensor [3]

## 6.4 IMAGE ADJUSTMENT

### 6.4.1 REGISTRATION ADJUSTMENT

#### *User Adjustment*

The paper registration can also be adjusted with the SOM ("Printer Configuration"). For details, see the "Software Guide".

#### *Service Adjustment*

1. Print the test page. (page 5-31 "Reports")
  - Print out the test page before changing the paper registration setting.
2. Start the SOM utility.
3. Click the "User Tools" tab.
4. Click "Printer Configuration".

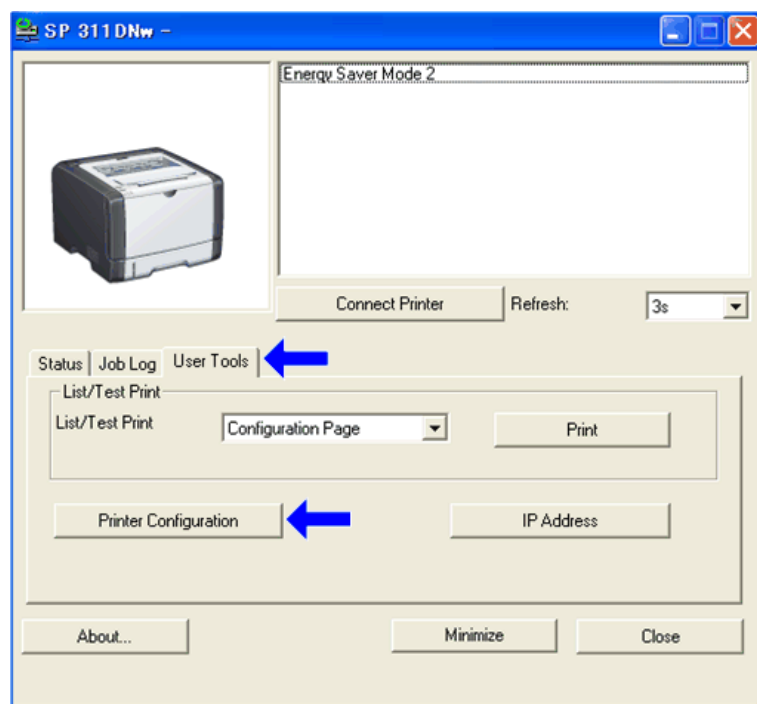

m1542108

5. The "Access Code" entry dialog appears.
6. Input the access code (for customer engineers).and then Click "OK".

## Image Adjustment

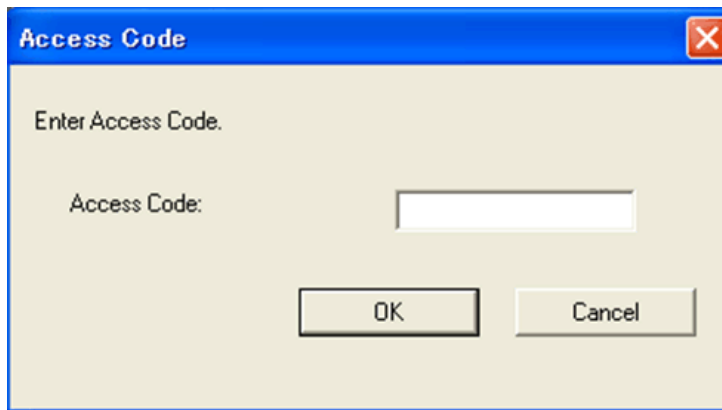

m1542111

7. Select the "SP Mode 1" tab.
8. Click "Up" or "Down" to set the registration value (mm) and then click "OK".

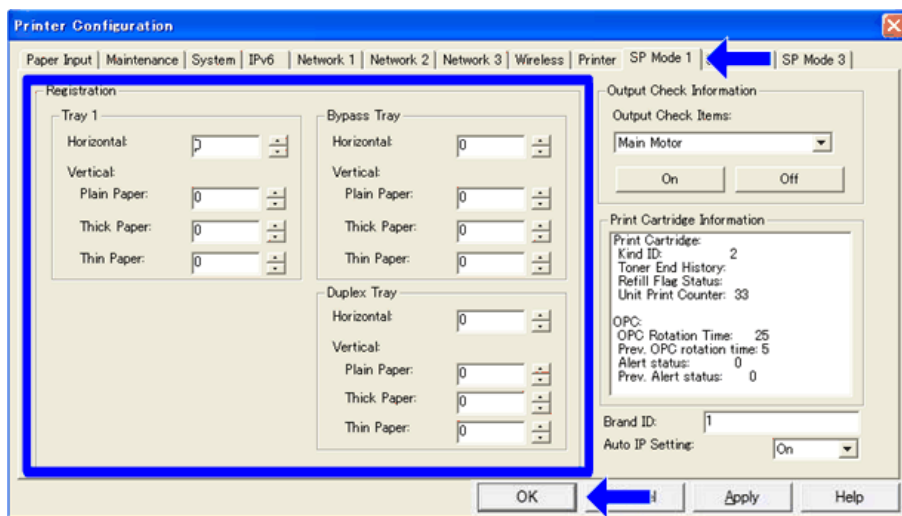

m1542123

### ↓ Note

- Increase the value to shift the print area in the plus direction.
- Decrease to shift in the minus direction.
- Adjust the margins of the test page so that they are equal in size.

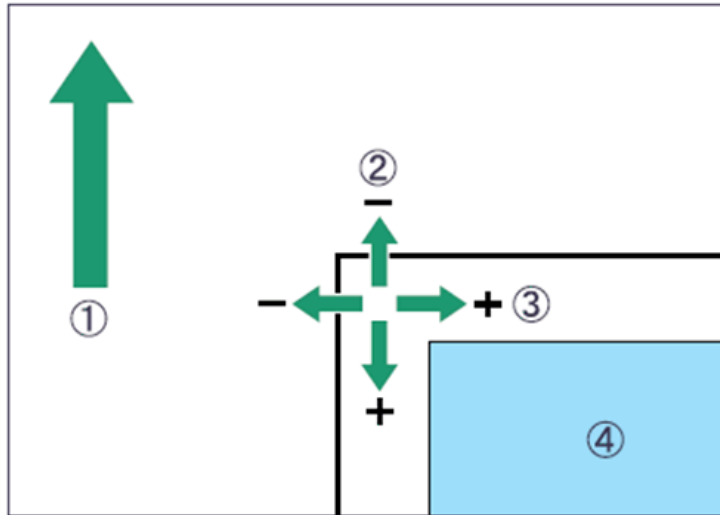

m016t500

- 
- (1): Feed Direction
- (2): Vertical Adjustment
- (3): Horizontal Adjustment
- (4): Print Area

9. Exit the SOM.

## 6.5 IMAGE QUALITY

### 6.5.1 OVERVIEW

Image problems may appear at regular intervals that depend on the circumference of certain components. The following diagram shows the possible symptoms (black or white dots at regular intervals).

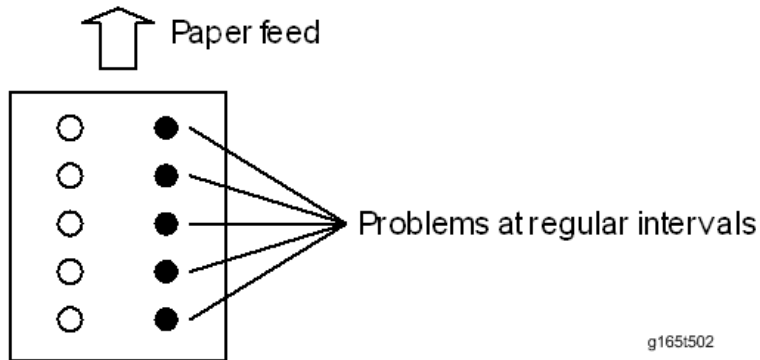

g165t502

- Abnormal image at 29.8 mm intervals: Charge roller
- Abnormal image at 37.7 mm intervals: Registration roller
- Colored spots at 37.9 mm intervals: Print cartridge (Development roller)
- Abnormal image at 45.8 mm intervals: Transfer roller
- Colored spots at 75.3 mm intervals: Print cartridge (OPC drum)
- Abnormal image at 94.2 mm intervals: Fusing unit (Pressure roller)
- Abnormal image at 93.1 mm intervals: Fusing unit (Hot roller)
- Abnormal image at 100.5 mm intervals: Paper feed roller

## 6.6 OTHER PROBLEMS

### 6.6.1 DARK LINES IN HALFTONE AREAS AT 75MM INTERVALS

Using the machine in a room where the humidity is too low may cause dark lines in halftone areas at 75mm intervals. This is because low-humidity conditions tend to cause variations in light sensitivity across the surface of the drum.

Selecting [On] for [Low Humidity Mode] under the [System] tab in [Printer Configuration] with SOM (Smart Organizing Monitor) may help to prevent these lines from appearing.

When the humidity mode setting is enabled, the drum is rotated slightly every 15 minutes. This keeps the light sensitivity constant across the entire surface of the drum.

## 6.7 TROUBLESHOOTING

### 6.7.1 JAM/PAPER FEED PROBLEM

problem	Cause/Solution
Paper does not feed smoothly.	<ul style="list-style-type: none"> <li>▪ Use supported types of paper.</li> <li>▪ Load paper correctly, making sure that the paper guides are properly adjusted.</li> <li>▪ If the paper is curled, straighten the paper.</li> <li>▪ Take out the paper from tray and fan it well. Then, reverse the top and bottom of the paper, and put it back in the tray.</li> </ul>
Paper jams occur frequently.	<ul style="list-style-type: none"> <li>▪ There remain pieces of paper in the paper path.</li> <li>▪ Poor contact or disconnection of the sensor.</li> <li>▪ There is some foreign body in the paper guides of the paper path.</li> <li>▪ If there are gaps between the paper and the paper guides, adjust the paper guides to remove the gaps.</li> <li>▪ Avoid printing on both sides of paper when printing images that contain large solid areas, which consume a lot of toner.</li> <li>▪ Use supported types of paper.</li> <li>▪ Load paper only as high as the upper limit markings on the paper guide.</li> <li>▪ Make sure that the friction pads and paper feed rollers are clean. Clean the Friction Pad and Paper Feed Roller.</li> </ul>

problem	Cause/Solution
Multiple sheets of paper are fed at one time.	<ul style="list-style-type: none"> <li>▪ Fan the paper well before loading. Also make sure that the edges are even by tapping the stack on a flat surface such as a desk.</li> <li>▪ Make sure that the paper guides are in the right position.</li> <li>▪ Use supported types of paper.</li> <li>▪ Load paper only as high as the upper limit markings on the paper guide.</li> <li>▪ Make sure that the friction pads and paper feed rollers are clean.</li> <li>▪ Check that paper was not added while there was still some left in the tray. Only add paper when there is none left in the tray.</li> </ul>
Paper gets wrinkles.	<ul style="list-style-type: none"> <li>▪ Deterioration of the hot roller or the pressure roller.</li> <li>▪ Paper is damp. Use paper that has been stored properly.</li> <li>▪ Paper is too thin.</li> <li>▪ If there are gaps between the paper and the paper guides, adjust the paper guides to remove the gaps.</li> </ul>
The printed paper is curled.	<ul style="list-style-type: none"> <li>▪ Load the paper upside down in the paper tray.</li> <li>▪ If the paper curl is severe, take prints from the output tray more frequently.</li> <li>▪ Paper is damp. Use paper that has been stored properly.</li> <li>▪ Adjust with “Curl Control mode” in the SP Mode 3.</li> </ul>
Images are printed diagonally to the pages.	If there are gaps between the paper and the paper guides, adjust the paper guides to remove the gaps.
Printed envelopes come out creased.	Check if the levers for printing on envelopes inside the rear cover are properly set. Lower the levers.

## 6.7.2 IMAGE QUALITY PROBLEM

problem	Cause/Solution
Blurred or too light	<ul style="list-style-type: none"> <li>▪ The polygon mirror of the laser unit is dirty.</li> <li>▪ Adjust the image density.</li> <li>▪ Paper is damp. Use paper that has been stored properly.</li> <li>▪ If you enable [Toner Saving], printing is generally less dense. Printer Driver &gt; Print Quality &gt; Toner Saving: Off</li> <li>▪ Toner is almost depleted. Replace the print cartridge.</li> <li>▪ Condensation may have collected. If rapid change in temperature or humidity occurs, use this machine only after it has acclimatized.</li> </ul>
Dirty or too dark	<ul style="list-style-type: none"> <li>▪ Image density is too high. Adjust the image density.</li> <li>▪ Toner on the printed surface is not dry. Do not touch printed surfaces immediately after copying. Remove freshly printed sheets one by one, taking care not to touch printed areas.</li> </ul>
Dirty background	<ul style="list-style-type: none"> <li>▪ Replace the print cartridge.</li> <li>▪ Adjust with "Adjust of Charge Bias" in the SP Mode 3.</li> </ul>
Vertical black lines	<ul style="list-style-type: none"> <li>▪ The stripper pawls of the fusing Unit are dirty.</li> <li>▪ Replace the print cartridge.</li> </ul>
Vertical White lines	Toner is almost depleted. Replace the print cartridge.
Horizontal black lines	Humidity level surrounding the machine may be too low. Refer to "Dark lines in halftone areas at 75mm Intervals".
A moire pattern is produced.	The original probably has heavily lined or dotted areas. Switching the setting for image quality between [Photo] and [Mixed] may eliminate the moire pattern.
Insufficient fusing	Check if the levers for printing on envelopes inside the rear cover are properly set. Pull up the levers.

# ENERGY SAVE

REVISION HISTORY		
Page	Date	Added/Updated/New
		None



## 7. ENERGY SAVE

### 7.1 ENERGY SAVE

#### 7.1.1 ENERGY SAVER MODES

Customers should use energy saver modes properly, to save energy and protect the environment.

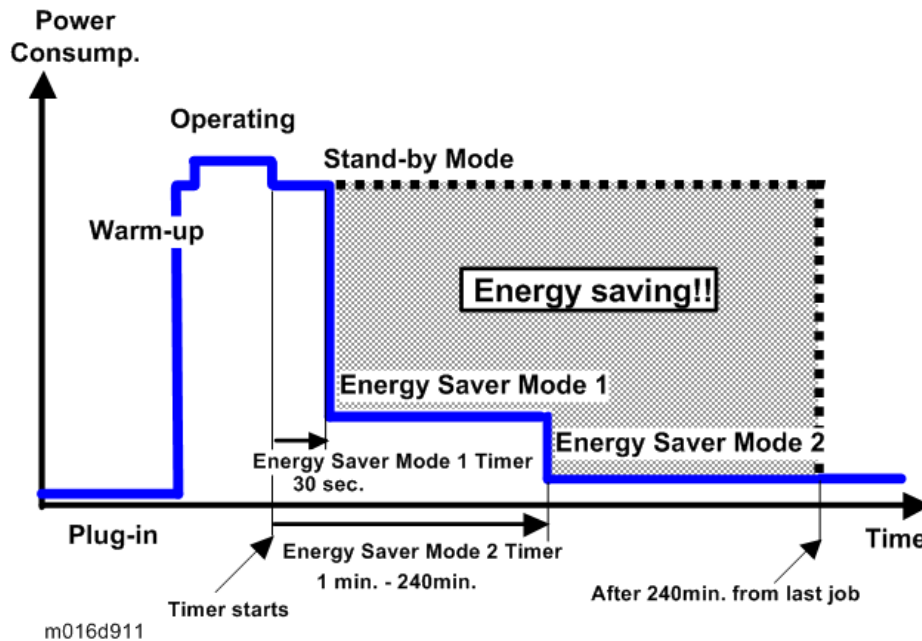

The backlight of the screen is turned off and "Energy Saver Mode1" appears on the screen, and then the fusing lamp is turned off and "Energy Saver Mode2" appears on the screen.

The area shaded grey in this diagram represents the amount of energy that is saved when the timers are at the default settings. If the timers are changed, then the energy saved will be different. For example, if the timers are all set to 240 min., the grey area will disappear, and no energy is saved before 240 min. expires.

#### **Timer Settings**

The user can set these timers with User Tools (SOM > Printer Configuration > System > Energy Saver Mode1 or Mode2)

- Energy Saver Mode 1 (30 sec.): This can be only turned on or off.
- Energy Saver Mode 2 (1 to 240 min.): This can be turned on or off and timer setting is adjustable (default: 1min.).

### ***Return to Stand-by Mode***

#### **Energy Saver Mode 1**

- Recovery time: 10 sec.

#### **Energy Saver Mode 2**

- Recovery time: 20 sec.

### ***Recommendation***

We recommend that the default settings should be kept.

- If the customer requests that these settings should be changed, please explain that their energy costs could increase, and that they should consider the effects on the environment of extra energy use.
- If it is necessary to change the settings, please try to make sure that the Energy Saver Mode 2 Timer is not too long. Try with a shorter setting first, such as 30 min., then go to a longer one (such as 60 min.) if the customer is not satisfied.
- If the timers are all set to the maximum value, the machine will not begin saving energy until 240 minutes has expired after the last job. This means that after the customer has finished using the machine for the day, energy will be consumed that could otherwise be saved.

## 7.2 PAPER SAVE

### 7.2.1 EFFECTIVENESS OF DUPLEX/COMBINE FUNCTION

Duplexing and the combine functions reduce the amount of paper used. This means that less energy overall is used for paper production, which improves the environment.

#### 1. Duplex:

Reduce paper volume in half!

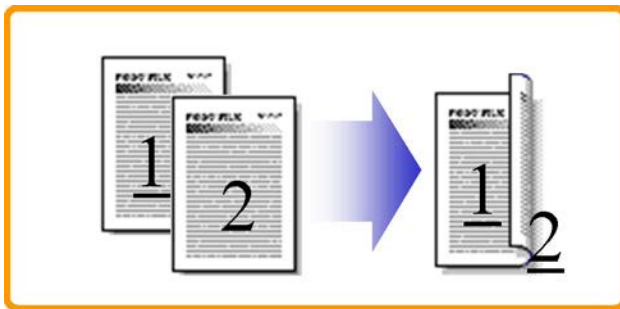

d062d102

#### 2. Combine mode:

Reduce paper volume in half!

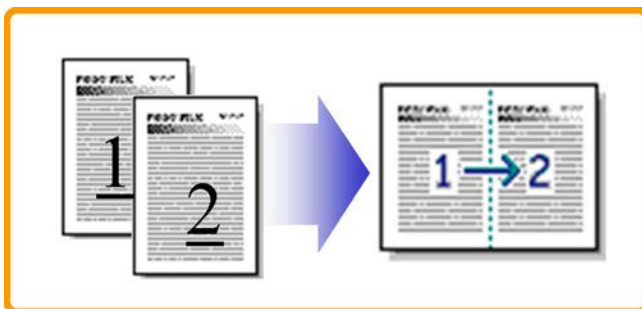

d062d100

3.

## Paper Save

Duplex + Combine:

Using both features together can further reduce paper volume by 3/4!

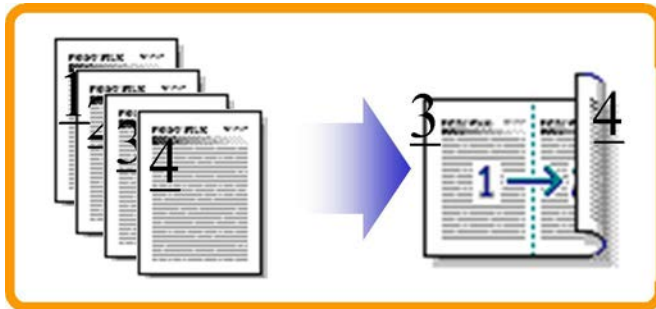

d062d101

To check the paper consumption, look at the total counter and the duplex counter.

The total counter counts all pages printed.

- For one duplex page, the total counter goes up by 2.
- For a duplex job of a three-page original, the total counter goes up by 3.

The duplex counter counts pages that have images on both sides.

- For one duplex page, the duplex counter goes up by 1.
- For a duplex job of a three-page original, the duplex counter will only increase by 1, even though two sheets are used.

### **Total counter**

This machine has a total sides printed counter only (so a duplex print is counted as two, not one).

You can check the total counter with the SOM or on the "Configuration Page".

- Total counter: SOM > "Printer Configuration" > "SP Mode 3" > "Counter Information" or "Configuration Page"

The following table shows paper savings and how the counters increase for some simple examples of single-sided and duplex jobs

**Duplex mode:**

Originals	Simplex Sheet used	Duplex Sheets used	Paper Saved	Total counter
1	1	1	<b>0</b>	1
2	2	1	<b>1</b>	2
3	3	2	<b>1</b>	3
4	4	2	<b>2</b>	4
5	5	3	<b>2</b>	5
10	10	5	<b>5</b>	10
20	20	10	<b>10</b>	20

If combine mode is used, the total and duplex counters work in the same way as explained previously. The following table shows paper savings and how the counters increase for some simple examples of duplex/combine jobs.

**2 in 1 mode:**

Originals	Simplex Sheet used	Duplex Sheets used	Paper Saved	Total counter
1	1	1	<b>0</b>	1
2	2	1	<b>1</b>	1
3	3	2	<b>1</b>	2
4	4	2	<b>2</b>	2
5	5	3	<b>2</b>	3
10	10	5	<b>5</b>	5
20	20	10	<b>10</b>	10

Paper Save

**Duplex + 2 in 1 mode:**

Originals	Simplex Sheet used	Duplex Sheets used	Paper Saved	Total counter
1	1	1	<b>0</b>	1
2	2	1	<b>1</b>	1
3	3	1	<b>2</b>	2
4	4	1	<b>3</b>	2
5	5	2	<b>3</b>	3
6	6	2	<b>4</b>	3
7	7	2	<b>5</b>	4
8	8	2	<b>6</b>	4
9	9	3	<b>6</b>	5
10	10	3	<b>7</b>	5
11	11	3	<b>8</b>	6
12	12	3	<b>9</b>	6

**M154/M155/M174/M175/  
M0A7/M287/M0BB  
SERVICE MANUAL APPENDICES**



**M154/M155/M174/M175/  
M0A7/M287/M0BB  
APPENDICES  
TABLE OF CONTENTS**

**1. APPENDICES: SPECIFICATIONS..... 1-1**

- 1.1 GENERAL SPECIFICATIONS..... 1-1
  - 1.1.1 GENERAL SPECIFICATIONS ..... 1-1
  - 1.1.2 PRINTER..... 1-3
- 1.2 SUPPORTED PAPER SIZES..... 1-4

**2. ERROR MESSAGES..... 2-1**

- 2.1.1 OVERVIEW..... 2-1
- 2.1.2 ERROR MESSAGES LIST ..... 2-1
  - Error and Status Messages Appear on Smart Organizing Monitor..... 2-1
  - Error and Status Indicate on the Control Panel..... 2-3



# APPENDIX: SPECIFICATIONS

REVISION HISTORY		
Page	Date	Added/Updated/New
		None



# 1. APPENDICES: SPECIFICATIONS

## 1.1 GENERAL SPECIFICATIONS

### 1.1.1 GENERAL SPECIFICATIONS

Configuration	Desktop	
Paper capacity	Main tray	250 sheets (80g/m <sup>2</sup> , 20lb)
	By-pass tray	50 sheets (80g/m <sup>2</sup> , 20lb)
	Output tray	Up to 125 sheets (A4/LT or 80g/m <sup>2</sup> , 20lb)
Paper size	Main tray	A4, B5 JIS, A5, B6 JIS, A6, Legal, Letter, HLT, Executive, F, Foolscap, Folio, 16K <b>Custom size:</b> Min. 90 x 148mm (3.6" x 5.8") Max. 216 x 356mm (8.5" x 14")
	By-pass tray	A4, B5, A5, B6, A6, Legal, Letter, HLT, Executive, F, Foolscap, Folio, 16K <b>Custom size:</b> Min. 90 x 148 mm (3.9" x 5.8") Max. 216 x 356 mm (8.5" x 14")
	Duplex	A4, Legal, Letter(8 1/2"x11")
Paper weight	Main tray	52-162 g/m <sup>2</sup> (14-43 lb)
	By-pass tray	52-162 g/m <sup>2</sup> (14-43 lb)
Machine size (W x D x H)	370 x 392 x 262 mm (14.6 x 15.4 x 10.3 inches)	
Weight (Machine body with consumables)	Approximately 12.7 Kg (28.0 lb) or less	
Energy Saver Mode	Selectable 1 to 240 minutes (1 minute steps)	
Power consumption	Maximum	US version: Less than 800 W EU/AP: Less than 890 W CH: Less than 850 W
	Ready mode	120W
	Power save mode	US/EU/AP: ▪ 50 W or less (Energy Saver Mode 1)

		<ul style="list-style-type: none"> <li>▪ 5.0 W or less (Energy Saver Mode 2)</li> </ul> CH: <ul style="list-style-type: none"> <li>▪ 70 W or less (Energy Saver Mode 1)</li> <li>▪ 10 W or less (Energy Saver Mode 2)</li> </ul>
Power	US	120V, 7A, 60Hz
	EU/AP	220 - 240 V, 4A, 50/60Hz
	CH	220 - 240 V, 5A, 50/60Hz
Noise	Printing	Less than 65.8 dB (A)
	Standby Mode	40 dB (A)
	Energy Saver	40 dB (A)
Warm-up time	26 seconds or less (23°C, 71.6°F)	
Machine life	5 years, 200,000 prints (whichever comes first)	
Environmental Standard	EnergyStar Tier 2 specifications	
Laser type	Class I	

## 1.1.2 PRINTER

Print speed	US	30 ppm (Letter)
	EU/CH/AP	28 ppm (A4)
Printer language	PCL6C	
Font	80 fonts	
Resolution	600 x 600 dpi (Maximum: 1200 x 600 dpi)	
Toner save mode	Supported	
First print speed	12 seconds or less	
Duplex print	Supported	
PC interface	<ul style="list-style-type: none"> <li>▪ Ethernet (10BASE-T, 100BASE-TX)</li> <li>▪ USB 2.0</li> <li>▪ Wi-Fi</li> </ul>	
Network	Protocol	TCP/IP, IPP
Memory	Standard/Max	128MB
Operation System	Win XP/Vista/7/8, server 2003/server 2008/server 2012 (32bit/64bit)	

## 1.2 SUPPORTED PAPER SIZES

A	Supported and the size is molded in the tray. Need to select paper size by operation panel/driver.
B	Supported but size is not molded in the tray. Need to select paper size by operation panel/driver. *For bypass tray, paper width is indicated.
C	Need to input paper size by operation panel and driver.
N	Not supported.

Type		SEF/LEF	Size	Input Tray		Type	
				Standard Tray	Duplex		
Plain Paper	A4	SEF	210x297mm	A	B	Y	
		LEF	297x210mm	N	N	N	
	B5	SEF	182x257mm	A	B	N	
		LEF	257x182mm	N	N	N	
	A5	SEF	148x210mm	A	B	N	
		LEF	210x148mm	N	C	N	
	B6	SEF	128x182mm	B	B	N	
		LEF	182x128mm	N	N	N	
	A6	SEF	105x148mm	B	B	N	
		LEF	148x105mm	N	N	N	
	Plain Paper	DLT	SEF	11" x 17"	N	N	N
		Legal	SEF	8 1/2"x14"	A	B	Y
Letter		SEF	8 1/2"x11"	A	B	Y	
		LEF	11"x 8 1/2"	N	N	N	
Half Letter		SEF	5 1/2" x 8 1/2"	B	B	N	
Executive		SEF	7 1/4"x10 1/2"	A	B	N	
		LEF	10 1/2"x7 1/4"	N	N	N	
Plain Paper	F	SEF	8" x 13"	B	N	N	
	Foolscap	SEF	8 1/2" x 13"	B	N	N	
	Folio	SEF	8 1/4" x 13"	B	N	N	
	8 Kai	SEF	267 x 390mm	N	N	N	
	16 Kai	SEF	195 x 267mm	B	B	N	
		LEF	267 x 195mm	N	N	N	

Envelope	Env. #10	Env. 10	SEF	4 1/8" x 9 1/2"	N	B
	Env. Monarch	Env. Monarch	SEF	3 7/8" x 7 1/2"	N	B
	Env. C6	Env. C6	SEF	114 x 162mm	N	B
	Env. C5	Env. C5	SEF	162 x 229mm	N	B
	Env. DL	Env. DL	SEF	110 x 220mm	N	B
Custom	Width	Width	-	100-216mm (3.6"x 8.5")	90-216mm (3.5"x 8.5")	N
	Length	Length	-	148 – 356mm (5.8"x 14.24")	140-356mm (5.5"x 14.24")	N



# ERROR MESSAGES

REVISION HISTORY		
Page	Date	Added/Updated/New
		None



## 2. ERROR MESSAGES

### 2.1.1 OVERVIEW

Error messages will be displayed on the LCD panel / Smart Organizing Monitor if the machine has a problem. These can be viewed by a customer.

### 2.1.2 ERROR MESSAGES LIST

*Error and Status Messages Appear on Smart Organizing Monitor*

Message	Causes	Solutions
No Response from I/O Device Check the cable, power cord, and main switch.	<ul style="list-style-type: none"> <li>▪ The power cable of the machine is not plugged in.</li> <li>▪ The power of the machine is not turned ON.</li> <li>▪ The USB cable is not connected.</li> </ul>	<ul style="list-style-type: none"> <li>▪ Check the printer power cord.</li> <li>▪ Check the printer power switch is on.</li> <li>▪ Check the USB cable is properly connected.</li> </ul>
Tray Not Detected or No Paper The indicated paper source tray is not set properly, or no paper loaded. Check the indicated tray.	Tray 1 has run out of paper. The bypass tray has run out of paper.	<ul style="list-style-type: none"> <li>▪ Load paper into Tray 1. See the user's guide "Loading Paper".</li> <li>▪ Load paper into the bypass tray. See the user's guide "Loading Paper".</li> </ul>
Tray 1 Jam Bypass Tray Jam Duplex Jam Inner Jam Outer Jam Total Jam	A paper jam has occurred in the machine.	Remove the jammed paper. See the user's guide "Paper Feed Problems".
Paper Size Mismatch Paper of the selected paper size is not loaded in the indicated paper source tray. Check the indicated tray.	The paper size specified on the machine and the size specified in the printer driver do not match.	For details about specifying the paper size setting on the machine, see the user's guide "Loading Paper". For details about changing the paper size setting in the printer driver, see the printer driver Help.

Paper Type Mismatch Paper of the selected paper type is not loaded in the indicated paper source tray. Check the indicated tray.	The paper type specified on the machine and the type specified in the printer driver do not match.	For details about changing the paper type setting of the machine, See the user's guide "Loading Paper". For details about changing the paper type setting in the printer driver, see the printer driver Help.
Print Cartridge is near empty.	The print cartridge is almost empty.	Prepare a new print cartridge.
Shortly printing becomes not available. Please keep Print Cartridge handy.	The machine has run out of the toner.	Replace the print cartridge. See the user's guide "Replacing the Print Cartridge".
Printing has been interrupted because of the memory overflow.	The data is too large or complex to print.	Select [600 x 600 dpi] in [Resolution:] to reduce the size of data. For details, see the printer driver Help.
Waste Toner full No printing is available. Open the indicated cover, and then replace Print Cartridge.	The waste toner bottle is full.	Replace the print cartridge.
No Toner or Waste Toner full No printing is available. Open the indicated cover, and then replace Print Cartridge.	The print cartridge has not been installed.	Reinstall the print cartridge. See the user's guide "Replacing the Print Cartridge".

## ***Error and Status Indicate on the Control Panel***

The LED on the operation panel indicates the machine status, including any errors.

LED			Status	Solution
Toner/ Paper End	Alarm	Power		
-	-	On	The power is on.	The status is normal.
-	-	Flashing	Importing data.	The status is normal.
Flashing	-	On	The print cartridge is almost empty.	Replace the print cartridge before it becomes empty.
On	-	On	<ul style="list-style-type: none"> <li>▪ The print cartridge is empty.</li> <li>▪ The print cartridge is not set correctly.</li> <li>▪ The tray has run out of paper.</li> </ul>	<ul style="list-style-type: none"> <li>▪ Replace the print cartridge.</li> <li>▪ Set the print cartridge again correctly.</li> <li>▪ Load paper into the tray.</li> </ul>
-	Flashing	On	A paper jam has occurred in the machine.	Use Web Image Monitor or Smart Organizing Monitor to determine where the paper jam is, and then remove the jammed paper. See the user's guide "Paper Feed Problems".
-	On	On	<ul style="list-style-type: none"> <li>▪ The size of paper to print on and the size of the paper loaded in the tray do not match.</li> <li>▪ A cover is open.</li> </ul>	<ul style="list-style-type: none"> <li>▪ Use Web Image Monitor or Smart Organizing Monitor to check the paper size settings, and then change either the size of paper to print on or the size of paper loaded in the tray.</li> <li>▪ Confirm that all the covers are closed completely.</li> </ul>
-	On	On	Another type of error has occurred.	Use Web Image Monitor or Smart Organizing Monitor

				to check the error, and then take appropriate measures. See the user's guide "Using Web Image Monitor" or "Using Smart Organizing Monitor".
On	On	On	A malfunction has occurred.	Contact your sales or service representative.