



RICOH UNIVERSITY

Learning ♦ Knowledge ♦ Performance



D115/D116
SERVICE MANUAL

006372MIU

LANIER RICOH SAVIN



D115/D116
SERVICE MANUAL

LANIER
RICOH
SAVIN



RICOH UNIVERSITY
Learning ♦ Knowledge ♦ Performance

D115/D116

SERVICE MANUAL

006372MIU

LANIER RICOH SAVIN

It is the reader's responsibility when discussing the information contained within this document to maintain a level of confidentiality that is in the best interest of Ricoh Americas Corporation and its member companies.

NO PART OF THIS DOCUMENT MAY BE REPRODUCED IN ANY FASHION AND DISTRIBUTED WITHOUT THE PRIOR PERMISSION OF RICOH AMERICAS CORPORATION.

All product names, domain names or product illustrations, including desktop images, used in this document are trademarks, registered trademarks or the property of their respective companies.

They are used throughout this book in an informational or editorial fashion only and for the benefit of such companies. No such use, or the use of any trade name, or web site is intended to convey endorsement or other affiliation with Ricoh products.

WARNING

The Service Manual contains information regarding service techniques, procedures, processes and spare parts of office equipment distributed by Ricoh Americas Corporation. Users of this manual should be either service trained or certified by successfully completing a Ricoh Technical Training Program.

Untrained and uncertified users utilizing information contained in this service manual to repair or modify Ricoh equipment risk personal injury, damage to property or loss of warranty protection.

Ricoh Americas Corporation

LEGEND

PRODUCT CODE	COMPANY		
	LANIER	RICOH	SAVIN
D115	LD220SPF	Aficio MP201SPF	902SPF
D116	LD220F	Aficio MP201F	902F

DOCUMENTATION HISTORY

REV. NO.	DATE	COMMENTS
*	02/2011	Original Printing

D115/D116

TABLE OF CONTENTS

PRODUCT INFORMATION

1. PRODUCT INFORMATION	1-1
1.1 SPECIFICATIONS	1-1
1.2 MACHINE CONFIGURATION	1-2
1.2.1 MAINFRAME	1-2
1.2.2 SYSTEM COMPONENTS	1-3
1.3 OVERVIEW.....	1-4
1.3.1 COMPONENT LAYOUT	1-4
Mainframe	1-4
ARDF	1-6
1.3.2 ELECTRICAL COMPONENTS	1-7
Electrical Components 1	1-7
Electrical Components 2	1-8
ARDF	1-9
1.3.3 PAPER PATH	1-10
1.3.4 DRIVE LAYOUT	1-11
Mainframe	1-11
ARDF	1-12
1.4 GUIDANCE FOR THOSE WHO ARE FAMILIAR WITH PREDECESSOR PRODUCTS.....	1-13

INSTALLATION

2. INSTALLATION	2-1
2.1 INSTALLATION CAUTIONS	2-1
2.2 INSTALLATION REQUIREMENTS.....	2-2
2.2.1 ENVIRONMENT	2-2
2.2.2 MACHINE LEVEL	2-2
2.2.3 MINIMUM OPERATIONAL SPACE REQUIREMENTS	2-3
2.2.4 POWER REQUIREMENTS	2-4
2.3 COPIER	2-5

2.3.1 ACCESSORY CHECK.....	2-5
Printer/Scanner and Fax Model (D115)/ Fax Model (D116)	2-5
Installation Procedure	2-6
Interface settings.....	2-10
Copier settings	2-11
Fax Settings	2-11
2.3.2 OPTIONAL HANDSET.....	2-12
Accessory Check	2-12
Installation Procedure	2-13
2.4 PAPER TRAY UNIT (D567).....	2-14
2.4.1 ACCESSORY CHECK.....	2-14
2.4.2 INSTALLATION PROCEDURE	2-14
2.5 PAPER TRAY UNIT HEATER	2-16
2.5.1 ACCESSORY CHECK.....	2-16
2.5.2 INSTALLATION PROCEDURE	2-17
2.6 USB 2.0/SD SLOT TYPE B.....	2-23
2.6.1 ACCESSORY CHECK.....	2-23
2.6.2 INSTALLATION PROCEDURE	2-23
When Installing the Handset	2-27
2.6.3 TESTING THE SD CARD/USB SLOT	2-28
2.7 OPTIONAL PAPER TRAY GRIP HANDLE	2-29
2.7.1 ACCESSORIES.....	2-29
Installation Procedure	2-29
2.8 CONTROLLER OPTIONS	2-31
2.8.1 OVERVIEW	2-31
2.8.2 WIRELESS LAN (IEEE 802.11A/G) INSTALLATION	2-32
Accessories.....	2-32
Installation Procedure	2-32
SP Mode Settings for IEEE 802.11a/g Wireless LAN.....	2-33
2.8.3 IEEE 1284 INSTALLATION	2-34
Accessories.....	2-34
Installation Procedure	2-34
2.8.4 VM CARD TYPE L (D467).....	2-35
Accessories.....	2-35
Installation.....	2-35
2.8.5 GIGABIT ETHERNET	2-36
2.8.6 HDD OPTION (D577)	2-37
Component Check	2-37

Installation Procedure	2-37
After Installing the HDD	2-39
Installing the Security Card	2-39
Activating the Security Applications	2-40
HDD Encryption Recovery from a Device Problem	2-41
Restoring the Encryption key	2-42
Clearing the NVRAM	2-43

PREVENTIVE MAINTENANCE

3. PREVENTIVE MAINTENANCE.....	3-1
3.1 MAINTENANCE TABLES	3-1
3.2 HOW TO CLEAR THE PM COUNTER	3-2

REPLACEMENT AND ADJUSTMENT

4. REPLACEMENT AND ADJUSTMENT	4-1
4.1 PRECAUTIONS	4-1
4.1.1 GENERAL.....	4-1
4.1.2 LITHIUM BATTERIES.....	4-1
4.1.3 HALOGEN-FREE CABLE	4-1
4.1.4 STATIC ELECTRICITY	4-1
4.2 SPECIAL TOOLS AND LUBRICANTS	4-2
4.3 EXTERIOR COVERS AND OPERATION PANEL	4-3
4.3.1 REAR COVER	4-3
4.3.2 COPY TRAY	4-4
4.3.3 OPERATION PANEL AND UPPER COVERS	4-5
4.3.4 RIGHT DOOR.....	4-6
4.3.5 BYPASS TRAY	4-6
4.3.6 PLATEN COVER SENSOR	4-7
4.4 SCANNER UNIT	4-8
4.4.1 EXPOSURE GLASS	4-8
4.4.2 LENS BLOCK	4-9
4.4.3 EXPOSURE LAMP, LAMP STABILIZER BOARD	4-10
4.4.4 SCANNER MOTOR.....	4-11
4.4.5 SCANNER HP SENSOR	4-12
4.4.6 SCANNER ALIGNMENT ADJUSTMENT	4-12
4.5 FUSING	4-14

4.5.1 FUSING UNIT	4-14
4.5.2 EXIT SENSOR.....	4-15
4.5.3 HOT ROLLER STRIPPER PAWLS.....	4-16
4.5.4 HOT ROLLER AND FUSING LAMP	4-17
4.5.5 THERMOSWITCHES AND THERMISTOR	4-18
4.5.6 PRESSURE ROLLER.....	4-19
4.5.7 CHECKING THE NIP BAND.....	4-20
4.6 PCU AND QUENCHING LAMP	4-21
4.6.1 PCU	4-22
4.6.2 QUENCHING LAMP	4-23
4.7 EXHAUST FAN AND MAIN MOTOR	4-24
4.7.1 EXHAUST FAN.....	4-24
4.7.2 MAIN MOTOR	4-25
4.8 PAPER FEED	4-26
4.8.1 PAPER FEED ROLLER AND FRICTION PAD	4-26
4.8.2 PAPER END SENSOR.....	4-26
4.8.3 REGISTRATION SENSOR.....	4-27
4.8.4 BYPASS PAPER END SENSOR.....	4-28
4.8.5 BYPASS FEED ROLLER.....	4-29
4.8.6 BYPASS FEED CLUTCH AND FRICTION PAD.....	4-30
4.8.7 PAPER FEED AND REGISTRATION CLUTCHES	4-31
4.9 IMAGE TRANSFER	4-32
4.9.1 TRANSFER ROLLER	4-32
4.9.2 ID SENSOR AND DUPLEX ROLLER.....	4-33
4.9.3 DISCHARGE PLATE	4-34
4.10 BICU AND CONTROLLER BOARD	4-35
4.10.1 BICU	4-35
Preparation.....	4-35
Procedure.....	4-35
4.10.2 CONTROLLER BOARD	4-36
Preparation:.....	4-36
Procedure.....	4-36
When installing a new controller board.....	4-39
When replacing the NVRAM on the controller board.....	4-40
4.11 OTHER REPLACEMENTS	4-42
4.11.1 DUPLEX MOTOR	4-42
4.11.2 HIGH-VOLTAGE POWER SUPPLY BOARD	4-43
4.11.3 PSU	4-44

4.11.4	CONTACT-RELEASE SOLENOID	4-45
4.11.5	TONER SUPPLY CLUTCH.....	4-46
4.11.6	FCU	4-47
	Lithium Batteries	4-47
	Procedure.....	4-47
4.12	LASER UNIT	4-49
4.12.1	LOCATION OF THE CAUTION DECAL	4-49
4.12.2	LASER UNIT.....	4-50
4.12.3	LD UNIT AND POLYGON MIRROR MOTOR.....	4-51
4.13	ARDF	4-52
4.13.1	ARDF	4-52
4.13.2	DF REAR COVER	4-53
4.13.3	ORIGINAL FEED UNIT.....	4-54
4.13.4	SEPARATION ROLLER	4-54
4.13.5	DF DRIVE BOARD	4-55
4.13.6	ORIGINAL SET AND DF INVERTER SENSOR	4-55
4.13.7	DF REGISTRATION AND DF EXIT SENSOR.....	4-56
	DF Registration Sensor Reflector.....	4-57
4.13.8	DF FEED MOTOR	4-58
4.13.9	DF TRANSPORT MOTOR.....	4-58
4.13.10	DF FEED CLUTCH.....	4-59
4.14	ADJUSTING COPY IMAGE AREA	4-60
4.14.1	PRINTING.....	4-60
	Adjusting Registration	4-60
	Adjusting Blank Margin.....	4-62
	Adjusting Main-Scan Magnification	4-63
4.14.2	SCANNING.....	4-63
	Adjusting Registration	4-63
	Adjusting Magnification	4-64
	Scan Auto Adjustment.....	4-65
4.14.3	DF IMAGE ADJUSTMENT	4-66

SYSTEM MAINTENANCE REFERENCE

5.	SYSTEM MAINTENANCE REFERENCE.....	5-1
5.1	SERVICE PROGRAM.....	5-1
5.1.1	SP TABLES	5-1
5.1.2	USING SP AND SSP MODES.....	5-1

Starting SP Mode	5-2
Selecting Programs	5-2
Specifying Values	5-2
Activating Copy Mode	5-2
Quitting Programs/Ending (S) SP Mode	5-3
Conventions used in the tables:	5-3
5.2 USING SP MODE	5-4
5.2.1 NVRAM DATA UPLOAD/DOWNLOAD	5-4
Uploading Content of NVRAM to an SD card	5-4
Downloading an SD Card to NVRAM	5-5
5.2.2 FIRMWARE UPDATE PROCEDURE	5-6
Before You Begin... ..	5-6
Firmware Update Procedure	5-7
5.2.3 TEST PATTERN PRINT (SP5-902-001)	5-12
Executing Test Pattern Printing	5-12
Test Patterns	5-12
5.2.4 MEMORY CLEAR	5-15
GW Machine	5-15
Exceptions	5-16
Memory Clear Procedure	5-16
5.2.5 MACHINE NO. SETTING (SP5-811-001)	5-17
Specifying Characters	5-17
GW Machine	5-17
Serial Number and NVRAM	5-17
5.2.6 SMC PRINT (SP5-990)	5-17
5.2.7 ID SENSOR ERROR ANALYSIS (SP2-221)	5-18
5.3 FAX SERVICE TABLES	5-19

TROUBLESHOOTING

6. TROUBLESHOOTING	6-1
6.1 SC TABLES	6-1
6.1.1 SUMMARY	6-1
6.1.2 ENGINE SC CODE DESCRIPTIONS	6-2
6.1.3 GW SC CODE DESCRIPTIONS	6-13
SC6xx	6-13
SC8xx	6-16
SC9xx	6-31

6.2 ELECTRICAL COMPONENT DEFECTS.....	6-34
6.2.1 SENSOR/SWITCH.....	6-34
6.2.2 BLOWN FUSE CONDITIONS.....	6-36
6.2.3 BICU LED DISPLAY	6-36
6.3 CARD SAVE FUNCTION.....	6-37
6.3.1 OVERVIEW	6-37
Card Save:	6-37
6.3.2 PROCEDURE.....	6-38
Error Messages.....	6-39
6.4 FAX TROUBLESHOOTING GUIDE.....	6-40

ENERGY SAVING

7. ENERGY SAVING	7-1
7.1 ENERGY SAVE	7-1
7.1.1 ENERGY SAVER MODES	7-1
Timer Settings	7-1
Recommendation	7-2
7.1.2 ENERGY SAVE EFFECTIVENESS.....	7-2
7.2 PAPER SAVE	7-4
7.2.1 EFFECTIVENESS OF DUPLEX/COMBINE FUNCTION	7-4
1. Duplex:	7-4
2. Combine mode:.....	7-4
3. Duplex + Combine:.....	7-5
Recommendation	7-5
Model S-C4.5	7-6

PAPER FEED UNIT PB1030 (D567)

SEE SECTION D567 FOR DETAILED TABLE OF CONTENTS

PRODUCT INFORMATION

APPENDIX: SPECIFICATIONS

TAB
POSITION 1

INSTALLATION

APPENDIX: PREVENTIVE MAINTENANCE

TAB
POSITION 2

PREVENTIVE MAINTENANCE

APPENDIX: SP MODE TABLES

TAB
POSITION 3

REPLACEMENT AND ADJUSTMENT

APPENDIX: FAX TROUBLESHOOTING GUIDE

TAB
POSITION 4

SYSTEM MAINTENANCE REFERENCE

APPENDIX: FAX SERVICE PROGRAM

TAB
POSITION 5

TROUBLESHOOTING

TAB
POSITION 6

ENERGY SAVING

TAB
POSITION 7

TAB
POSITION 8

READ THIS FIRST

Important Safety Notices

Prevention of Physical Injury

1. Be sure that the power cord is unplugged before disassembling or assembling parts of the copier or peripherals.
2. The wall outlet should be near the copier and easily accessible.
3. Note that electrical voltage is supplied to some components of the copier and the paper tray unit even while the main power switch is off.
4. If any adjustment or operation check has to be made with exterior covers off or open while the main switch is turned on, keep hands away from electrified or mechanically driven components.
5. If you start a job before the copier completes the warm-up or initializing period, keep hands away from the mechanical and electrical components until job execution has started. The copier will start making copies as soon as warm-up or initialization is finished.
6. The inside and the metal parts of the fusing unit become extremely hot while the copier is operating. Be careful to avoid touching those components with your bare hands.

Health Safety Conditions

Toner and developer are nontoxic, but getting either of these into your eyes may cause temporary eye discomfort. Try to remove with eye drops or flush with water. If material remains in eye or if discomfort continues, get medical attention.

Observance of Electrical Safety Standards

The copier and its peripherals must be installed and maintained by a customer service representative who has completed the training course on those relevant models.

WARNING

- Keep the machine away from flammable liquids, gases, and aerosols. A fire or an explosion might occur if this precaution is not observed.

Lithium Batteries

Incorrect replacement of lithium battery(s) on the FCU, controller board and memory board unit may pose risk of explosion. Replace only with the same type or with an equivalent type recommended by the manufacturer. Discard used batteries in accordance with the manufacturer's instructions.

Safe and Ecological Disposal

1. Do not incinerate toner bottles or used toner. Toner dust may ignite suddenly if exposed to an open flame.
2. Dispose of used toner, developer, and organic photoconductors in accordance with local regulations. (These are nontoxic supplies.)
3. Dispose of replaced parts in accordance with local regulations.
4. When keeping used lithium batteries in order to dispose of them later, do not put more than 100 batteries per sealed box. Storing larger numbers or not sealing them apart may lead to chemical reactions and heat build-up.

Laser Safety

The Center for Devices and Radiological Health (CDRH) prohibits the repair of laser-based optical units in the field. The optical housing unit can only be repaired in a factory or at a location with the requisite equipment. The laser subsystem is replaceable in the field by a qualified Customer Engineer. The laser chassis is not repairable in the field. Customer engineers are therefore directed to return all chassis and laser subsystems to the factory or service depot when replacement of the optical subsystem is required.

WARNING

- Use of controls not specified in this manual, or performance of adjustments or procedures not specified in this manual, may result in hazardous radiation exposure.

⚠ WARNING FOR LASER UNIT

⚠ WARNING

- Turn off the main switch before attempting any of the procedures in the Laser Unit section. Laser beams can seriously damage your eyes.

CAUTION MARKING:

**CAUTION
VORSICHT**

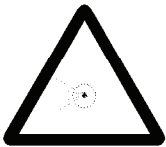



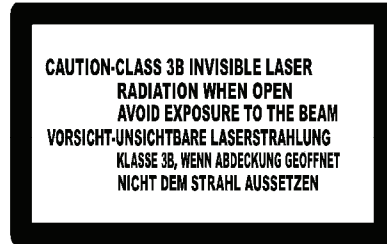



>PS<



b262r934

Symbols and Abbreviations

This manual uses several symbols and abbreviations. The meaning of those symbols and abbreviations is as follows:

	See or Refer to
	Clip ring
	E-ring
	Screw
	Connector
	Clamp
SEF	Short Edge Feed
LEF	Long Edge Feed
-	Core Technology manual



Short Edge Feed (SEF)

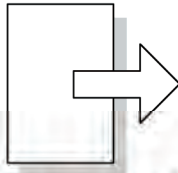

Long Edge Feed (LEF)

Cautions, Notes, etc.

The following headings provide special information:

⚠ WARNING

- Failure to obey warning information could result in serious injury or death.

⚠ CAUTION

- Obey these guidelines to ensure safe operation and prevent minor injuries.

↓ Note

- This information provides tips and advice about how to best service the machine.

PRODUCT INFORMATION

REVISION HISTORY		
Page	Date	Added/Updated/New
		None

1. PRODUCT INFORMATION

1.1 SPECIFICATIONS

See "Appendices" for the following information:

- General Specifications
- Supported Paper Sizes

1.2 MACHINE CONFIGURATION

1.2.1 MAINFRAME

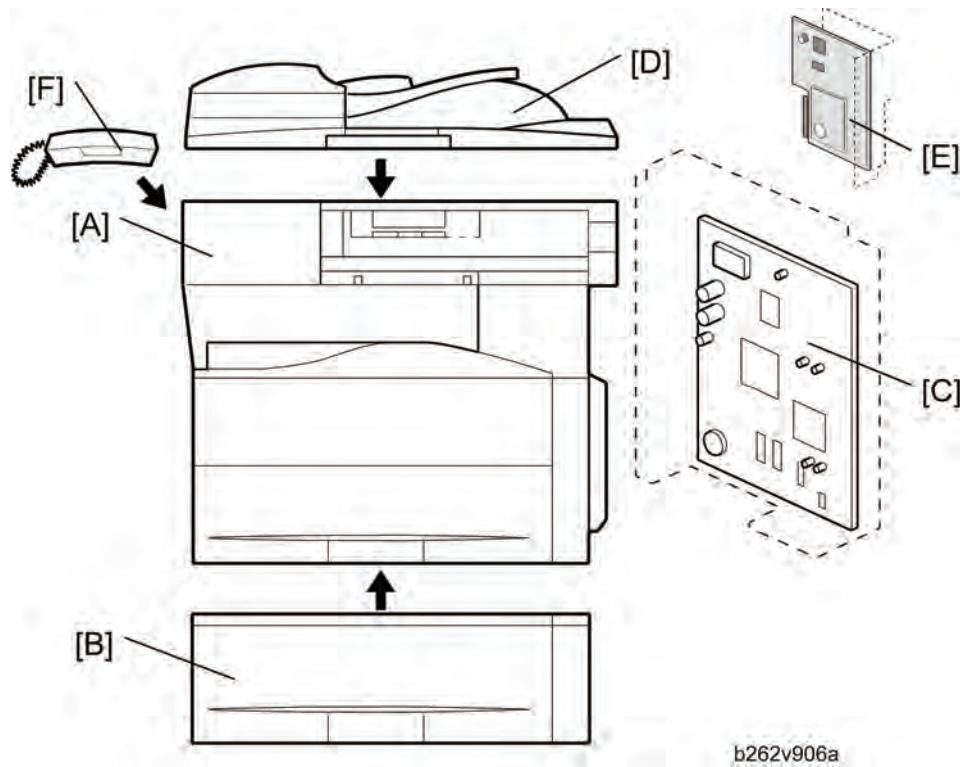

	Standard Component	Machine Code	Remarks
1	Copier [A]	D115/D116	-
2	GW Controller Board [C]	-	Standard
3	ARDF [D]	-	Standard
4	Fax Unit [E]	-	Standard

	Optional Components	Machine Code	Remarks
5	500-sheet Paper Feed Unit [B]	D567	Two can be used.
6	Handset [F]	B433	NA only

1.2.2 SYSTEM COMPONENTS

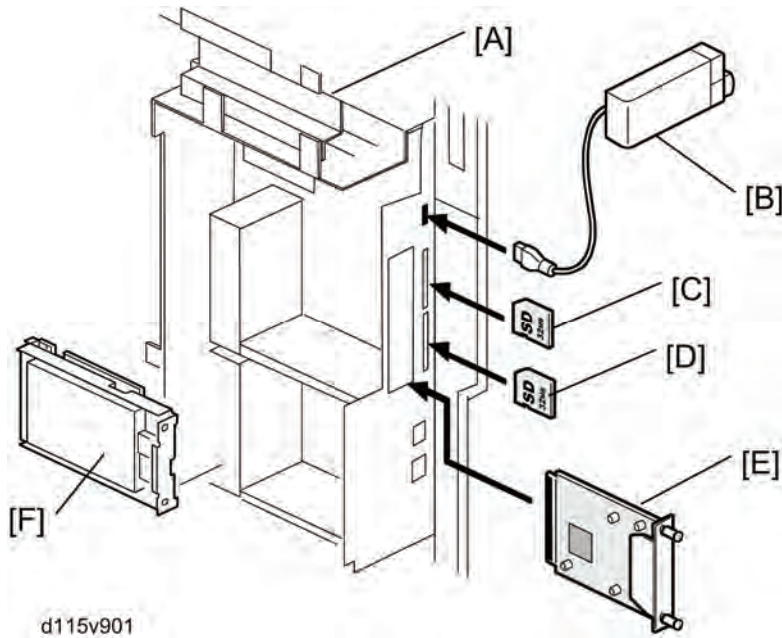

Item	Machine Code		Remarks
Controller Box	-	[A]	Standard
USB2.0/SD Slot	D467	[B]	Option only for D115
Printer/Scanner unit	D468	[C]	SD card for the Printer/Scanner Unit Standard only for D115
VM Card	D467	[D]	In SD slot 2 (lower)
IEEE 1284	B679	[E]	One from the four
Wireless LAN	M344	[E]	
Gigabit Ethernet Board	G874	[E]	
HDD with Security Card	D577	[F]	Merge the Security Card into the Printer/Scanner SD card.

1.3 OVERVIEW

1.3.1 COMPONENT LAYOUT

Mainframe

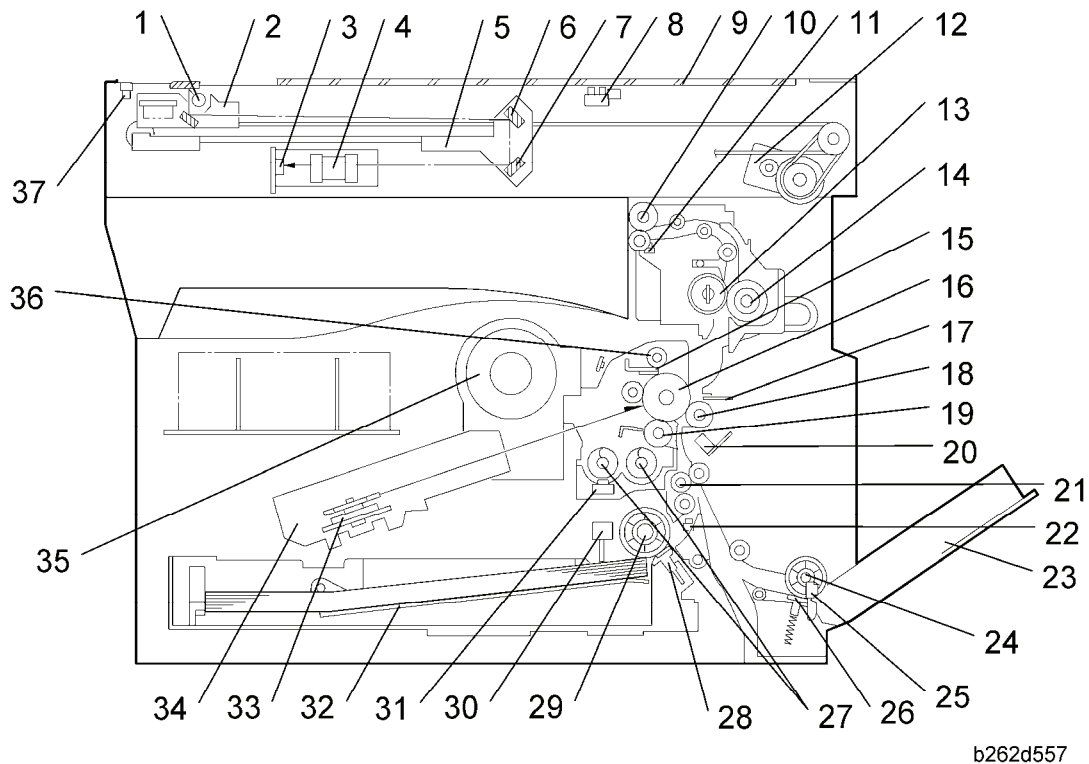

1. Exposure Lamp	20. ID (Image Density) Sensor
2. 1st Scanner	21. Registration Roller
3. CCD (on SBU)	22. Registration Sensor
4. Lens Block	23. Bypass Tray
5. 2nd Scanner	24. Bypass Paper Feed Roller
6. 2nd Mirror	25. Bypass Paper End Sensor
7. 3rd Mirror	26. Bypass Friction Pad
8. Platen Cover Sensor	27. Mixing Augers
9. Exposure Glass	28. (Main) Friction Pad

10. Exit Roller	29. Paper Feed Roller
11. Exit Sensor	30. Paper End Sensor
12. Scanner Motor	31. TD (Toner Density) Sensor
13. Hot Roller	32. Bottom Plate
14. Pressure Roller	33. Polygon Mirror Motor
15. Cleaning Blade	34. Laser Unit
16. OPC Drum	35. Toner Supply Bottle (or THM)
17. Discharge Plate	36. Toner Collection Coil
18. Transfer Roller	37. Scanner HP Sensor
19. Development Roller	

ARDF

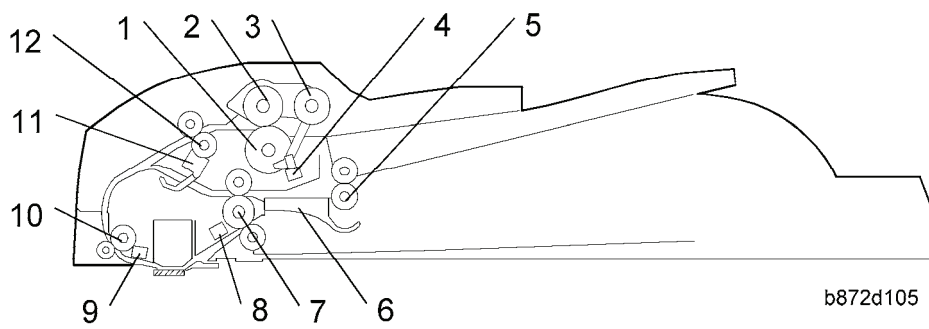

1. Separation Roller	7. Exit Roller
2. Paper Feed Roller	8. Exit Sensor
3. Pick-up Roller	9. Registration Sensor
4. Original Set Sensor	10. Registration Roller
5. Inverter Roller	11. Inverter Sensor
6. Junction Gate	12. Transport Roller

1.3.2 ELECTRICAL COMPONENTS

Electrical Components 1

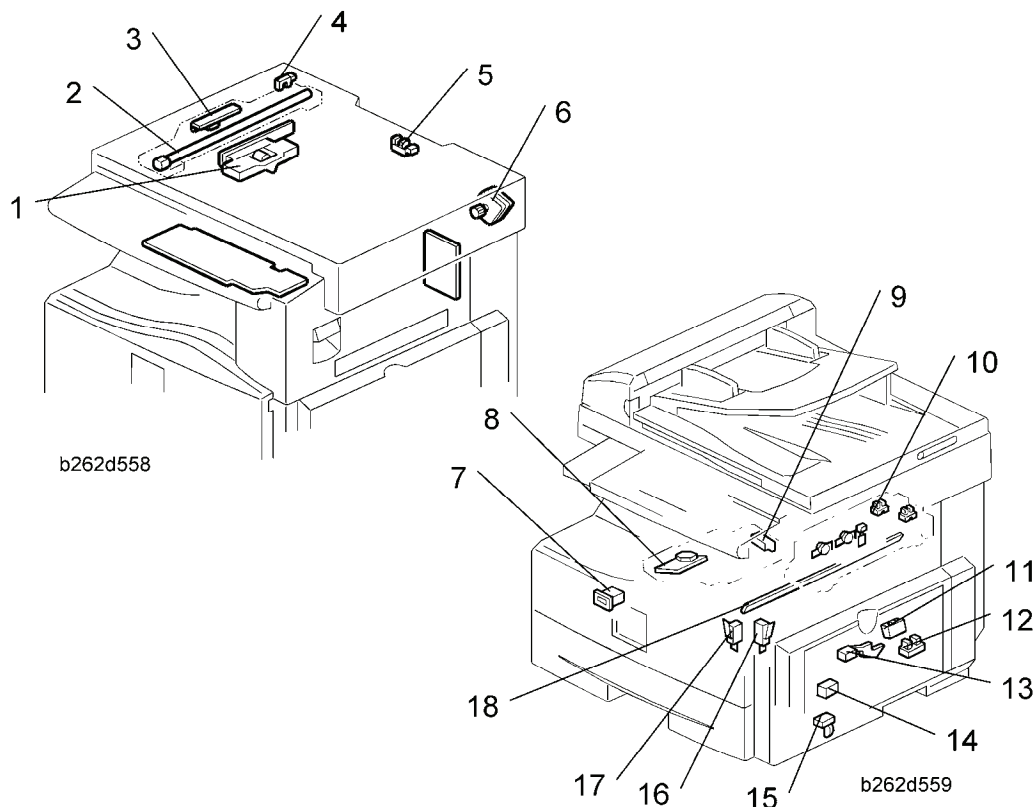

1. Lens Block	11. ID (Image Density) Sensor
2. Exposure Lamp	12. Registration Sensor
3. Lamp Stabilizer Board	13. Paper End Sensor
4. Scanner HP Sensor	14. Toner Density Sensor
5. Platen Cover Sensor	15. Bypass Paper End Sensor
6. Scanner Motor	16. Right Door Safety Switch
7. Mechanical Counter	17. Front Door Safety Switch
8. Polygon Mirror Motor	18. Quenching Lamp
9. LD Unit	19. High-Voltage Power Supply Board
10. Exit Sensor	20. Operation Panel Board

Electrical Components 2

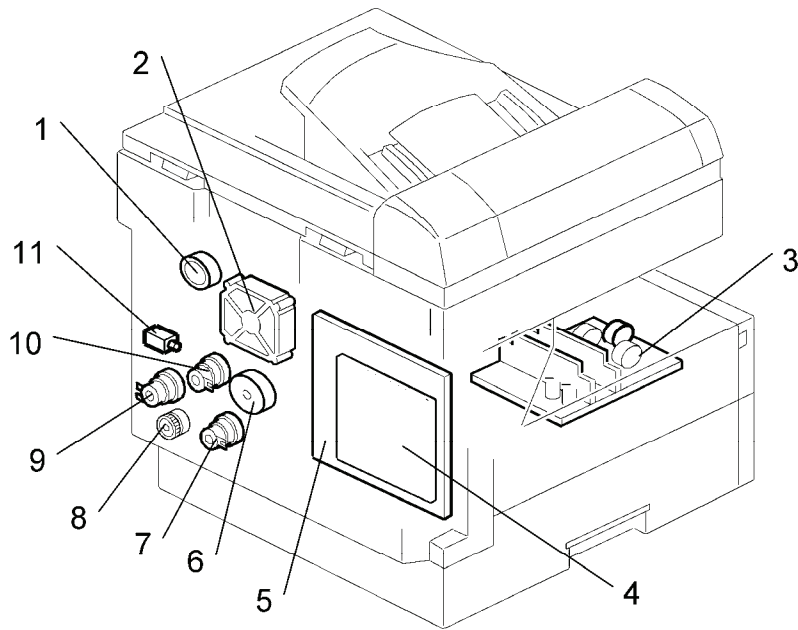

b262d560

1. Duplex Motor	7. Paper Feed Clutch
2. Exhaust Fan	8. Toner Supply Clutch
3. PSU	9. Bypass Feed Clutch
4. Controller Board (GW)	10. Registration Clutch
5. BICU	11. Fusing Solenoid
6. Main Motor	

ARDF

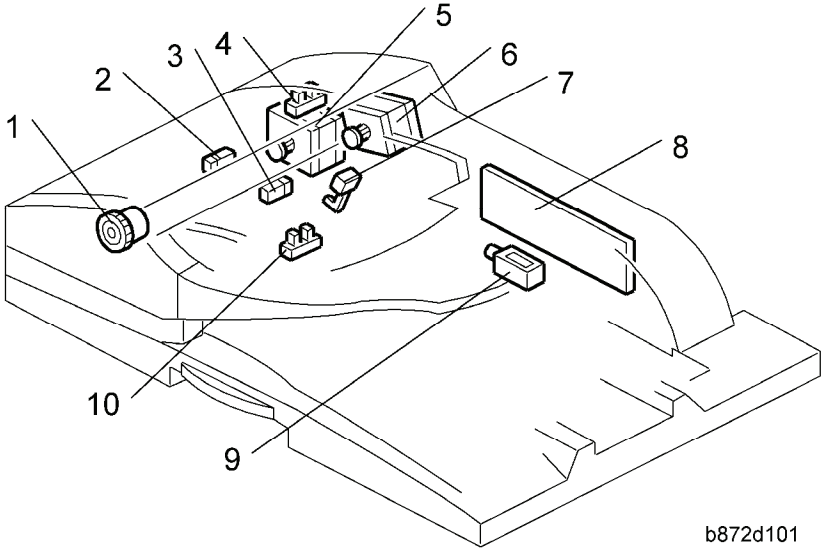

b872d101

1. DF Feed Clutch	6. DF Feed Motor
2. Registration Sensor	7. Inverter Sensor
3. Exit Sensor	8. DF Drive Board
4. Left Cover Sensor	9. Junction Gate Solenoid
5. DF Transport Motor	10. Original Set Sensor

1.3.3 PAPER PATH

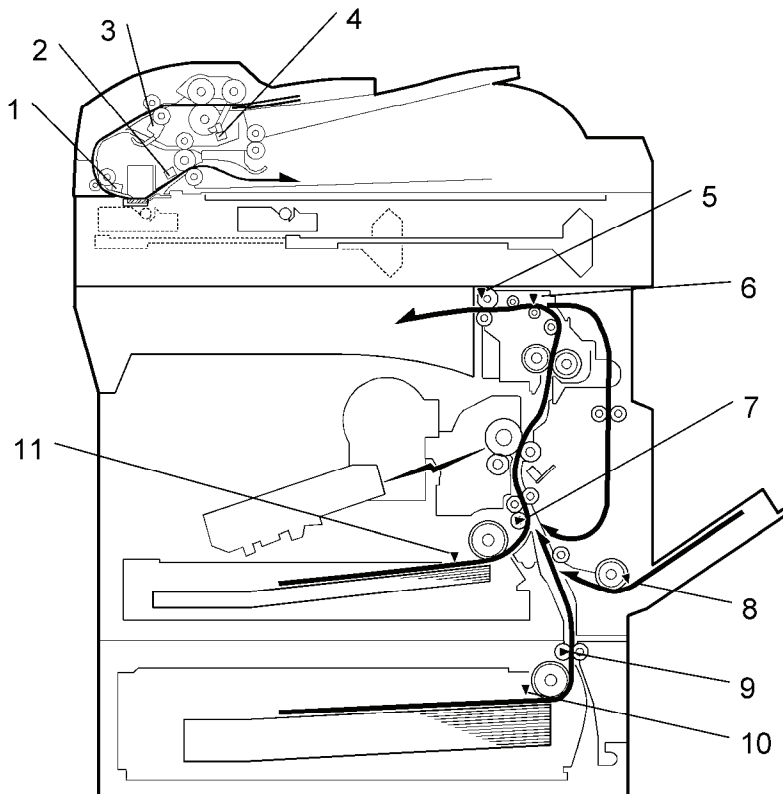

b130d905

1. Original Registration Sensor (Document Feeder)
2. Exit Sensor (Document Feeder)
3. Inverter Sensor (Document Feeder)
4. Original Set Sensor (Document Feeder)
5. Exit Sensor
6. Paper Path Sensor
7. Registration Sensor
8. By-pass Paper End Sensor
9. Paper Feed Sensor (Optional Tray)
10. Paper End Sensor (Optional Tray)
11. Paper End Sensor

1.3.4 DRIVE LAYOUT

Mainframe

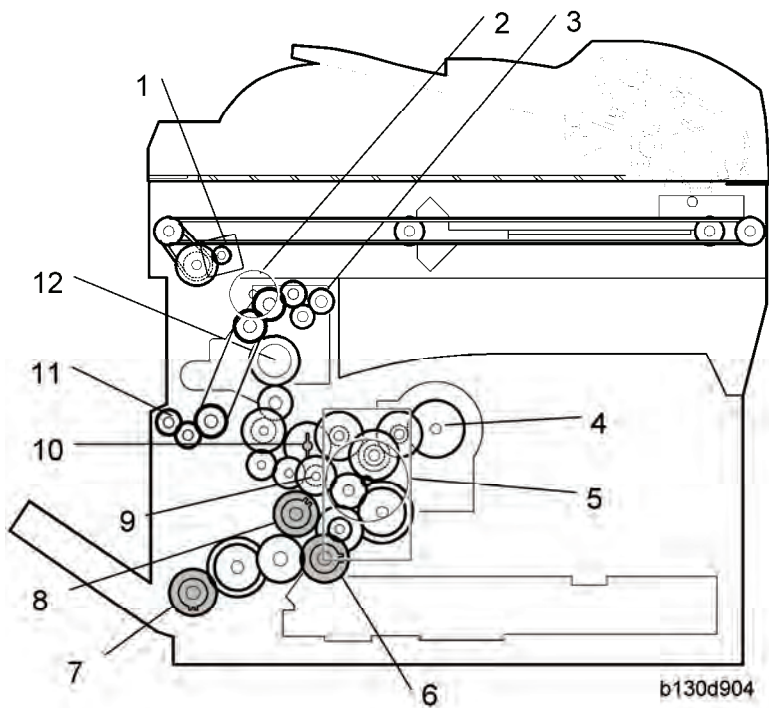

1. Scanner Motor	7. Bypass Feed Clutch (By-pass Tray)
2. Duplex motor	8. Registration Clutch
3. Exit Roller	9. Developer Driver Gear
4. Toner Bottle Clutch	10. Drum Drive Gear
5. Main Motor	11. One-way Gear (Duplex Unit)
6. Paper Feed Clutch	12. Fusing Drive Gear

ARDF

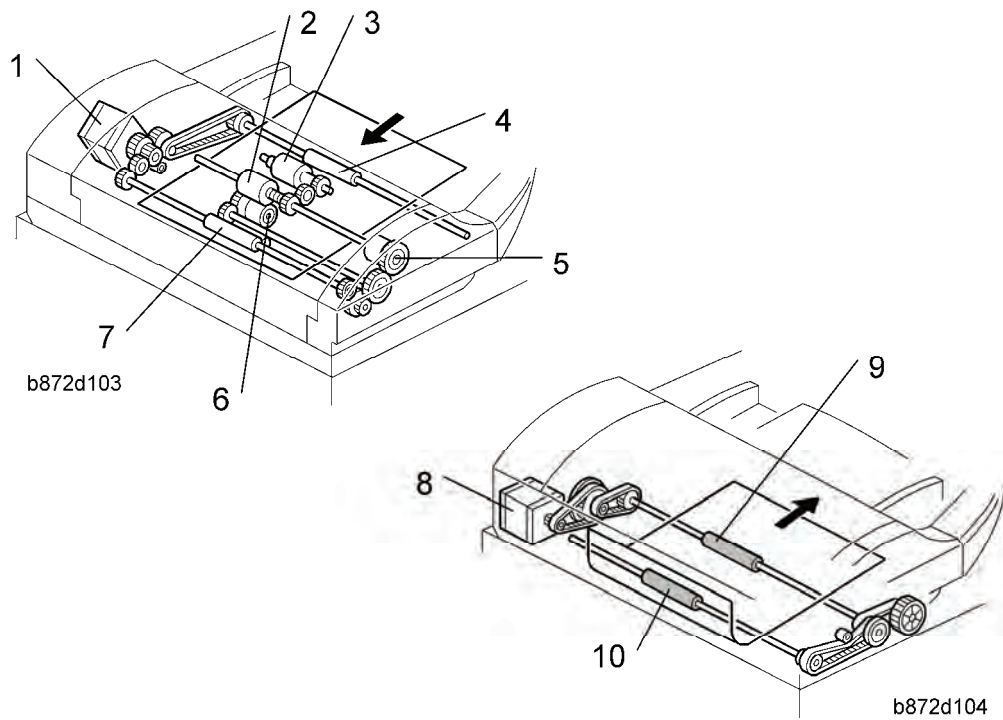

1. DF Feed Motor	6. Separation Roller
2. Feed Roller	7. Transport Roller
3. Pick-up Roller	8. DF Transport Motor
4. Inverter Roller	9. Exit Roller
5. DF Feed Clutch	10. Registration Roller

- DF Feed Motor: Drives the feed, separation, pick-up, and transport and inverter rollers.
- DF Transport Motor: Drives the registration and exit rollers.

1.4 GUIDANCE FOR THOSE WHO ARE FAMILIAR WITH PREDECESSOR PRODUCTS

The D115/D116 range of machines is the successor model to the D068/D069 range of machines. If you have experience with the predecessor line, the following information may be of help when you read this manual.

Differences from Predecessor Products

	D115/D116	D068/D069
Security Card (HDD Encryption and Data Overwrite Security Unit)	Standard only for D115	Option only for D069
Copying Speed	20 cpm: Memory copy 16 cpm: ADF 1 to 1	17cpm: Memory copy 16cpm: ADF 1 to 1

★ Important

- The following parts are unique for D115/D116. When replacing the following parts, use the parts specified for each model. **DO NOT mix up** the following parts for D067/D068/D069/D072 and D115/D116. Otherwise, both of the machine operation and output quality are not guaranteed.
1. BICU with Controller Unit
 - If wrong part is installed, an image is not correctly copied on outputs with the DF one to one copy.
 2. Laser Unit (Writing Unit)
 - If wrong part is installed, a copied image might be too dark or light on outputs.
 3. Polygon Scanner Motor (A part of Laser Unit)
 - If wrong part is installed, a copied image might be too dark or light on outputs or an SC might be issued.
 4. Model Name Plate
 5. Mechanical Counter (S-C4: Assembled, S-C4.5: Service optional part)

INSTALLATION

REVISION HISTORY		
Page	Date	Added/Updated/New
11	4/28/2011	Copier Settings

2. INSTALLATION

2.1 INSTALLATION CAUTIONS

CAUTION

- Before installing an optional unit, do the following:
- Print out all messages stored in the memory, all user-programmed items, and a system parameter list.
- If there is a printer option on the machine, print out all data in the printer buffer.
- Turn off the main switch and disconnect the power cord, the telephone line, and the network cable.

2.2 INSTALLATION REQUIREMENTS

2.2.1 ENVIRONMENT

–Temperature and Humidity Chart–

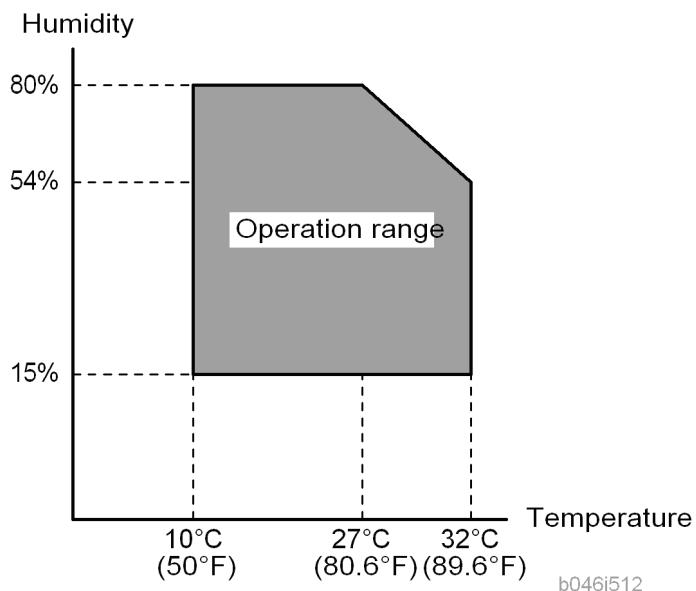

- Temperature Range: 10°C to 32°C (50°F to 89.6°F)
- Humidity Range: 15% to 80% RH
- Ambient Illumination: Less than 1,500 lux (Do not expose to direct sunlight.)
- Ventilation: Room air should turn over at least 3 times/hr/person
- Ambient Dust: Less than 0.1 mg/m³
- Do not install the machine where it will be exposed to direct sunlight or to direct airflow (from a fan, air conditioner, air cleaner, etc.).
- Do not install the machine where it will be exposed to corrosive gas.
- Place the machine on a firm and level base.
- Do not install the machine where it may be subjected to strong vibration.

2.2.2 MACHINE LEVEL

Front to back:	Within 5 mm (0.2") of level
Right to left:	Within 5 mm (0.2") of level

2.2.3 MINIMUM OPERATIONAL SPACE REQUIREMENTS

Place the machine near the power source, providing clearance as shown.

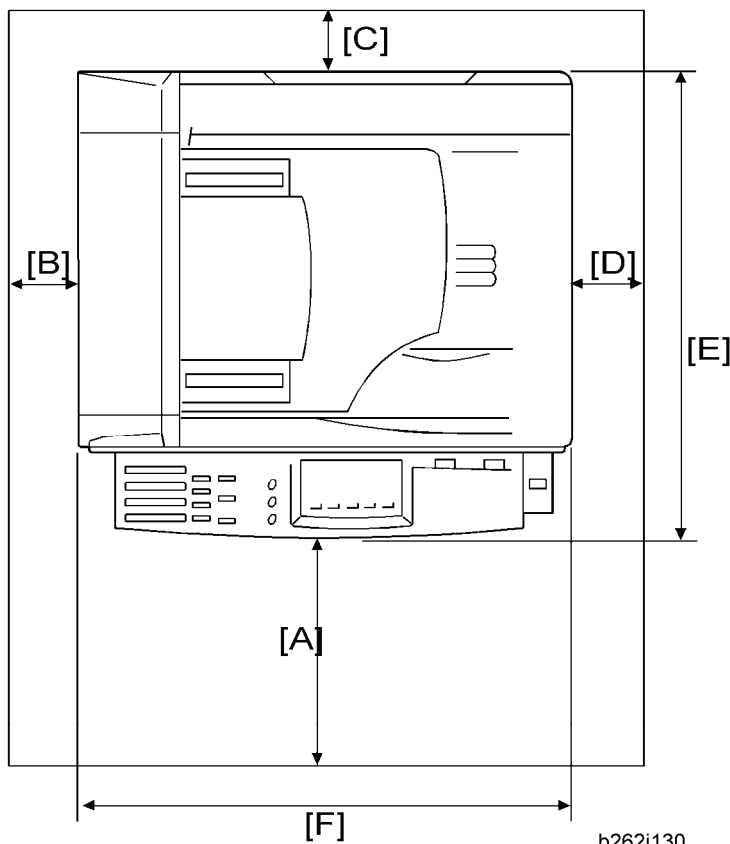

A: Front – 750 mm (29.6")

B: Left – 100 mm (3.9")

C: Rear – 100 mm (3.9")

D: Right – 100 mm (3.9")

E: Depth – 450 mm (17.7")

F: Width – 485 mm (19.1")

↓ Note

- The 750-mm front space indicated above is sufficient to allow the paper tray to be pulled out. Additional space is required to allow an operator to stand at the front of the machine.
- Actual minimum space requirement for left, rear, and right sides is 10mm (0.4") each, but note that this will not allow room for opening of the bypass tray, right door or ARDF unit.

2.2.4 POWER REQUIREMENTS

CAUTION

- Make sure that the wall outlet is near the machine and easily accessible. After completing installation, make sure the plug fits firmly into the outlet.
- Avoid multiple connections to the same power outlet.
- Be sure to ground the machine.

Input voltage:

North America:	110 – 120 V, 60 Hz, 8 A
Europe:	220 – 240 V, 50/60 Hz, 4 A

Image quality guaranteed at rated voltage $\pm 10\%$.

Operation guaranteed at rated voltage $\pm 15\%$.

2.3 COPIER

2.3.1 ACCESSORY CHECK

Printer/Scanner and Fax Model (D115)/ Fax Model (D116)

Description	Q'ty
NECR (-17)	1
EU Safety Sheet (-27)	1
Paper Size Decal (-17, -27, -29)	1
Operating Instructions – Book (-17, -29)	1 set
Operating Instructions – CD ROM (-17, -29)	1 set
Handset Bracket (-17)	1
Screw for Handset Bracket (-17)	2
Modular Cable (-17)	1
Connector Cover for TEL (-17)	1
Ferrite Core for TEL Line	1
Ferrite Core (-17, -27, -29)	1
EMC Caution Sheet (-27)	1
EULA Sheet (-17, -27, -29)	1
Caution Decal (-17, -27, -29)	1

Installation Procedure

CAUTION

- Make sure that the copier remains unplugged during installation.

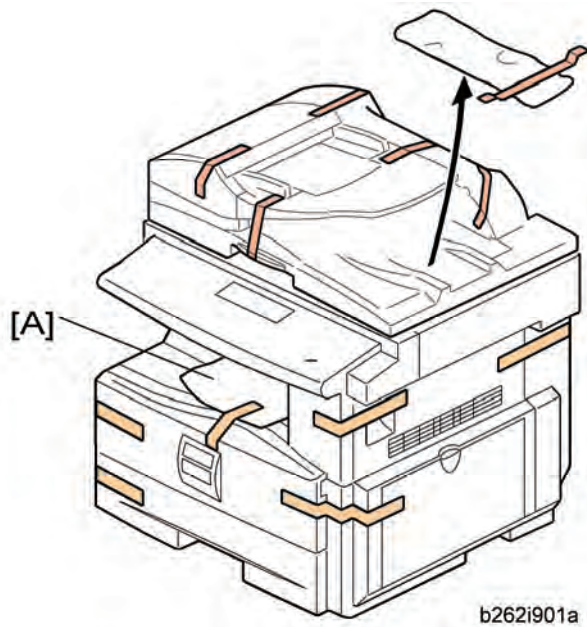

1. Remove the all strips of tape.
2. Remove the bag [A], SMC and A3 sheet of paper on the exposure glass.

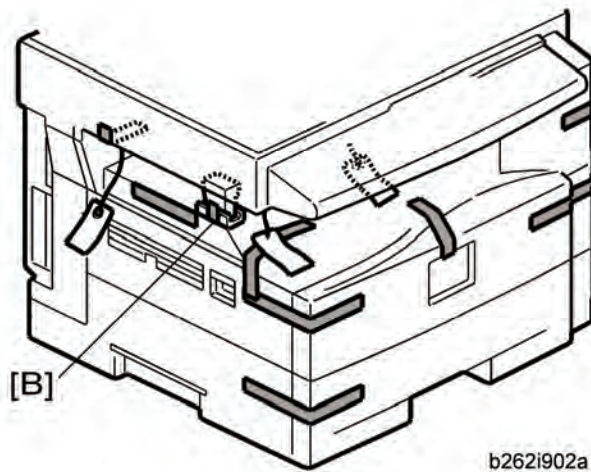

3. Remove the spacing wedge [B].

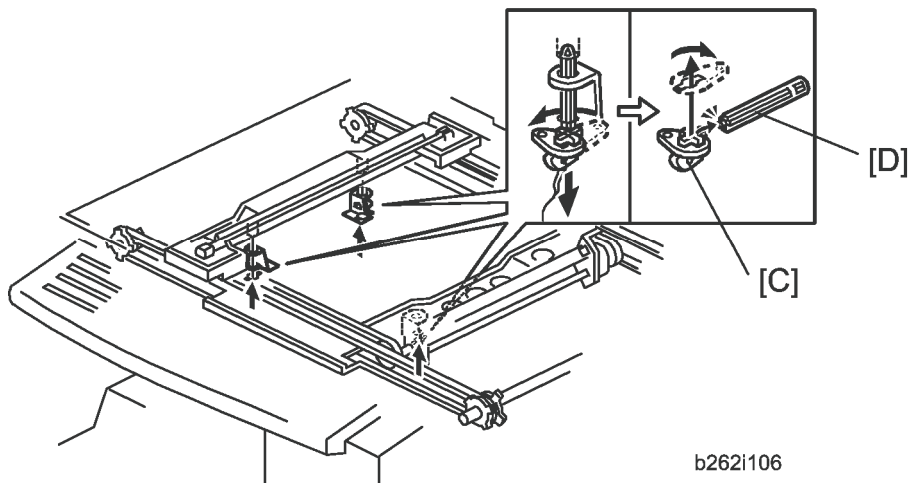

4. Remove the three scanner lock pins. (A tag is hanging from each pin.) To remove: Grasp the base of the pin [C], turn the pin 90 degrees, and pull it down and out.
5. Remove the tags from the pins.
6. Break each pin off the base [C].
7. Discard the pin part [D].
8. Set each base [C] back into its original hole, turning it 90° to lock it into place. (Be sure to do this for all three pins.)

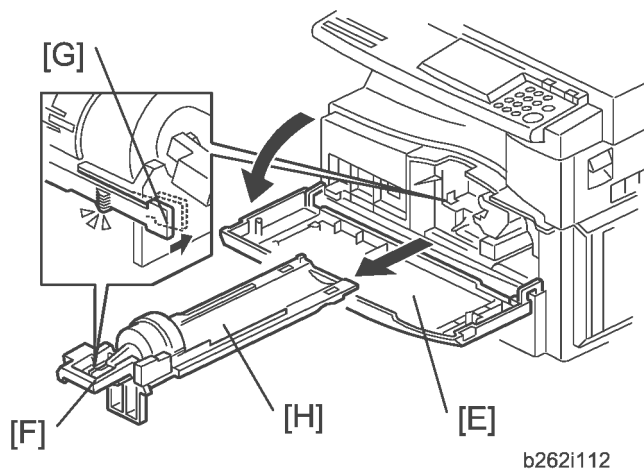

9. Open the front door [E].
10. Lift lever [F], press in on latch [G] and pull the bottle holder [H] out. (You do not need to pull it completely out of the machine.)
11. Take a new bottle of toner, and shake it several times.

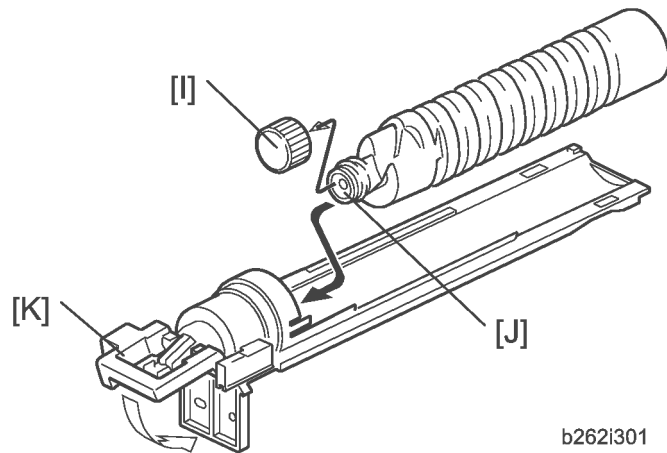

12. Remove the outer cap [I].



- Do not remove the inner cap [J].

13. Load the bottle on the holder.



- Do not forcefully turn the toner bottle on the holder. After you turn on the main power switch, the copier sets the bottle in place.

14. Push the bottle holder back into the machine.

15. Press the latch [K] down to lock the holder.

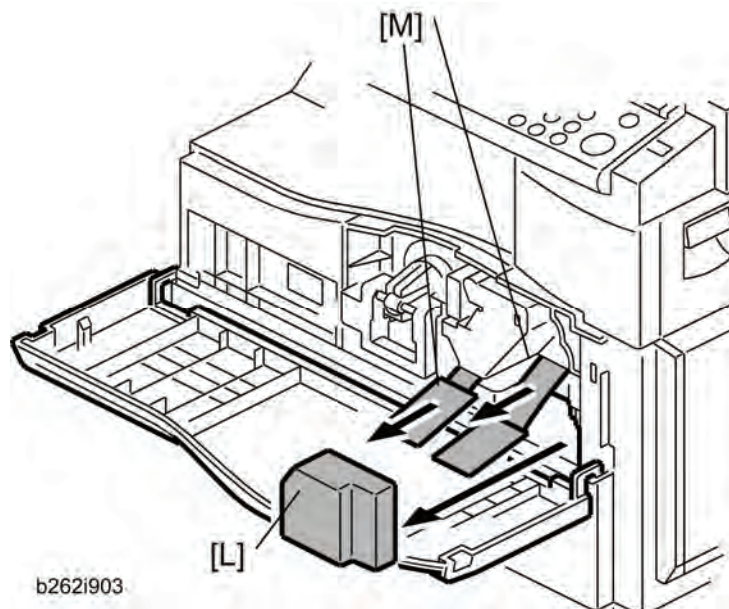

16. Remove the padding [L].

17. Pull each tabbed strip [M] out of the PCU with one hand, supporting the PCU with the other.



- Do not pull both strips at the same time, as this could damage the PCU.

18. Close the front door.

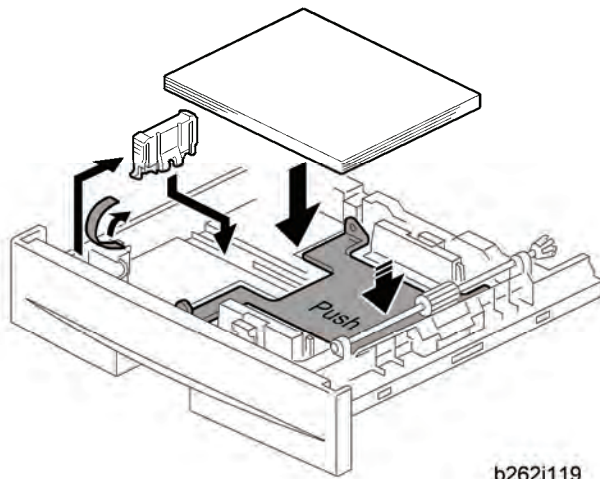

19. Pull out the paper tray, and remove the tape securing the end fence in the compartment.
20. Push the bottom plate down, and then load the paper.
21. Adjust the side fences. If you load paper shorter than A4, set the end fence in the correct position.
22. Push the tray back into the copier.

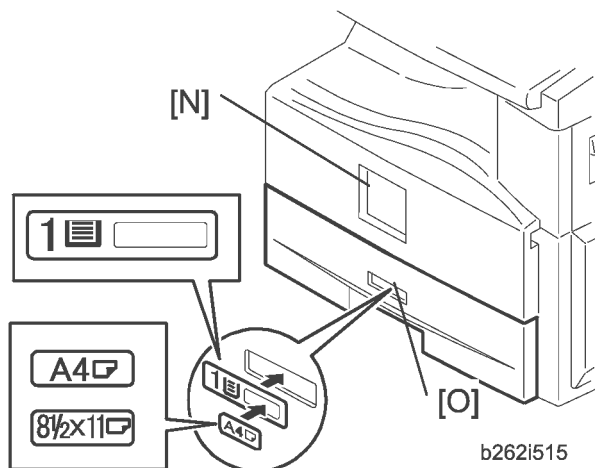

23. Attach the appropriate Brand Decal to the center [N] of the front door if necessary.
24. Attach the appropriate tray number decal and paper-size decal to the paper tray [O].
25. Install optional units (if any).

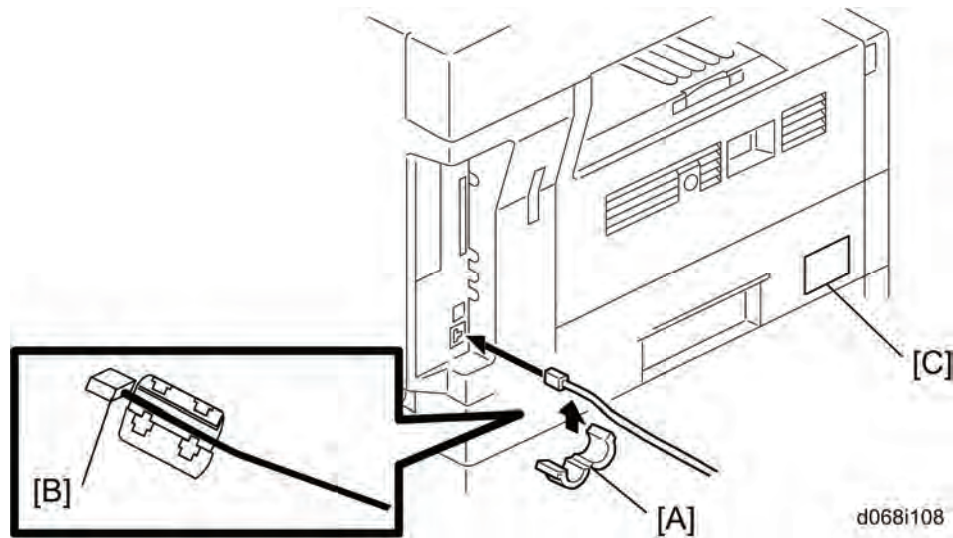

26. Attach the ferrite core [P] to the network cable when connecting the cable.
27. Attach the ferrite core to the telephone line in the same manner as step 26.
28. Connect the telephone line to the "LINE" jack.

↓ Note

- The end of the ferrite core must be about 10 cm (4") from the end of the cable.

29. Plug in the machine and turn on the main power switch.
30. Select the language used in the operation panel as necessary ( > Language).

Interface settings

For D115:

1. Start the SP mode.
2. Select SP5-985-001 (NIC setting) and change the setting value to "1" (ON).
3. Select SP5-985-002 (USB setting) and change the setting value to "1" (ON).
4. Turn the main switch off and on.

For D116:

1. Start the SP mode.
2. Select SP5-985-001 (NIC setting) and change the setting value to "0" (OFF).
3. Select SP5-985-002 (USB setting) and change the setting value to "0" (OFF).
4. Turn the main switch off and on.

Copier settings

1. Start the SP mode.
2. Select SP5-801-001 and execute the initialization.
3. Exit the SP mode, and then start the UP mode.
- ⇒ 4. Select the "@Remote Service" ("User Tool" > "System Settings > Administrator Tools" > "Extended Security" > @Remote Service") and select **"Do Not Prohibit"**.
5. Exit the UP mode, and then start the SP mode.
6. Select SP5-870-003 and execute initialization for @Remote.
7. Select SP5-907-001 and specify the "Plug & Play".
8. Select SP5-870-001 and execute writing certification for @Remote S.
9. Select SP5-302-002 and specify the time zone.
10. Select SP5-307-001, 003, and 004 and specify the daylight-saving-time settings.
11. Exit the SP mode and turn the main switch off and on.
12. Start the UP mode.
13. Specify the date and time with "Set Date" or "Set Time" (User Tool" > "System Settings" > "Set Date" or "Set Time").
14. Turn the main switch off and on.
15. Check the operations.
16. Make a full size copy, and check if the side-to-side and leading edge registrations are correct. If they are not, adjust the registrations.

Fax Settings

Initializing the Fax unit

When you press the Fax key for the first time after installation, the error "SRAM problem occurred / SRAM was formatted" will show on the LCD for initializing the program of the fax unit. Turn the main power switch off/on to clear the error display.



- If another error occurs after initialization, this can be a functional problem.
1. Select fax SP1-101-016 and specify the country code.
 2. Select fax SP3-101-001 and specify the service station.

2.3.2 OPTIONAL HANDSET

Accessory Check

Check that you have the components and accessories.

No.	Description	Q'ty
1	Handset	1
2	Handset cradle	1
3	Screws	2
4	Handset manual	1

Note

- The handset bracket is not included in the optional handset kit. The bracket is provided as an accessory of the copier.

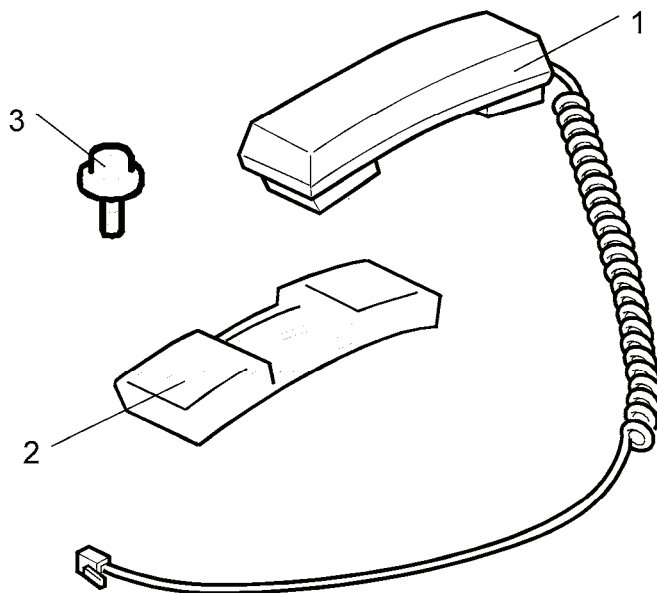

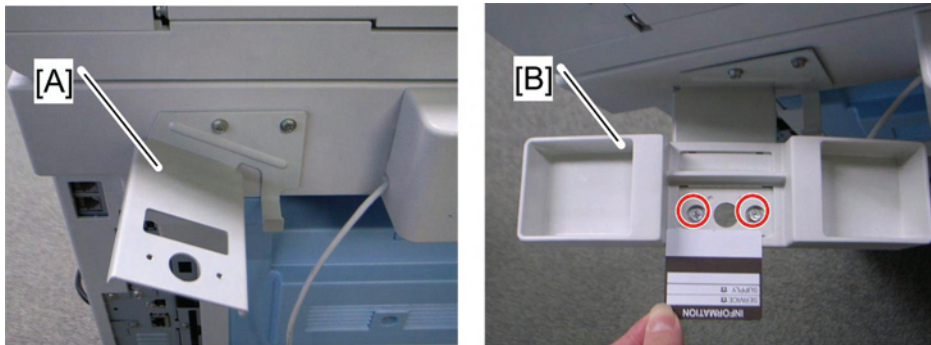

b130i908

Installation Procedure



d068i011

1. Attach the handset bracket [A] ( x 2)
2. Remove the label from the handset cradle [B].
3. Attach the cradle [B] to the handset bracket ( x 2).
4. Attach the cradle to the bracket ( x 2).
5. Reattach the label.

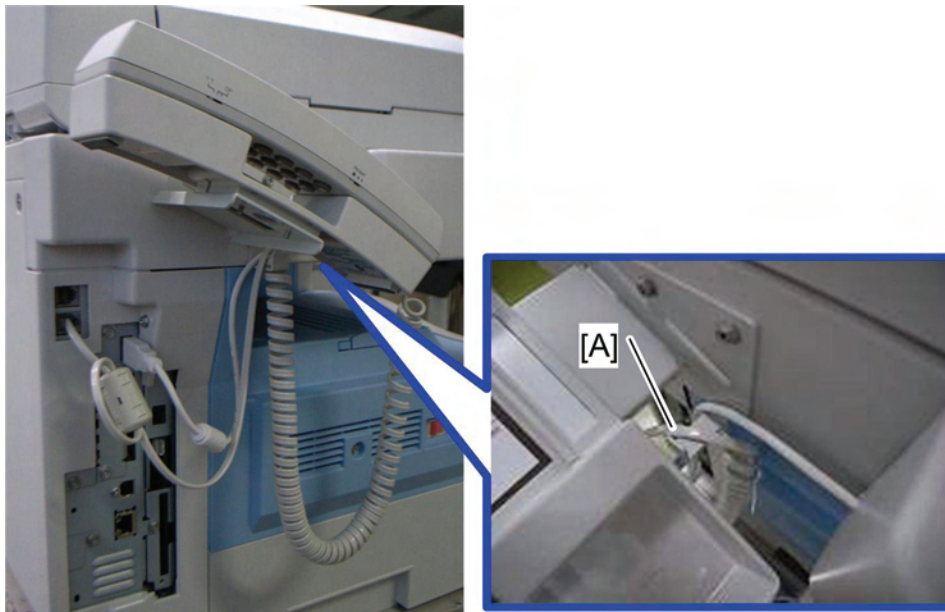

d068i013

Note

- The bracket is an accessory of the copier.

6. Set the handset on the cradle.
7. Connect the handset cable to the "TEL" jack and set the telephone cable [A] as shown above.

2.4 PAPER TRAY UNIT (D567)

2.4.1 ACCESSORY CHECK

Confirm that you have these accessories.

Description	Q'ty
1. Paper-size decals	1 sheet
2. Installation Procedure (for service technicians)	1
3. Installation Procedure (for users)	1
4. Tapping Screw: M3x10	1
5. EMC Caution Sheet	1

2.4.2 INSTALLATION PROCEDURE

CAUTION

- Unplug the main machine's power cord before starting the following procedure.

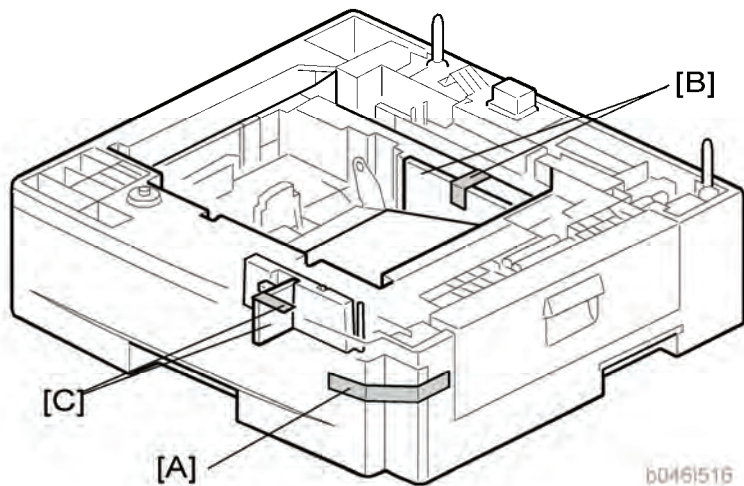

- Remove the tape at [A], and the tape and cardboard at [B].
- Pull the paper tray part way out of the unit, remove the tape and cardboard at [C], and push the tray back in.

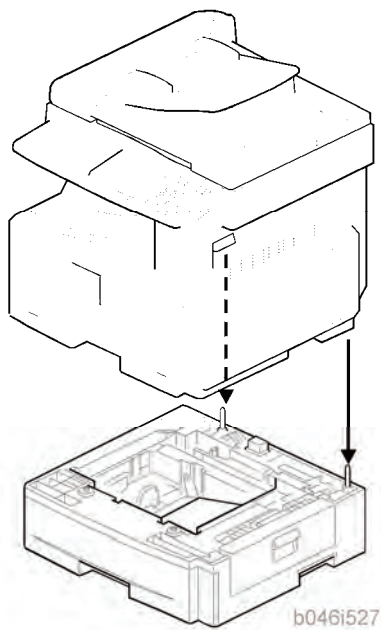

3. Set the machine on the paper tray unit.

↓ Note

- When installing a second paper tray unit, place on the first paper tray unit before placing the copier onto the pair of paper tray units
4. Remove the paper(s) tray from the paper tray unit(s).
 5. Load paper into the paper tray(s). Adjust the side and end fences as necessary. If loading 8¹/₂"x 14" paper, remove the end fence and set it into the special compartment.
 6. Set the paper tray(s) back into the paper tray unit(s).

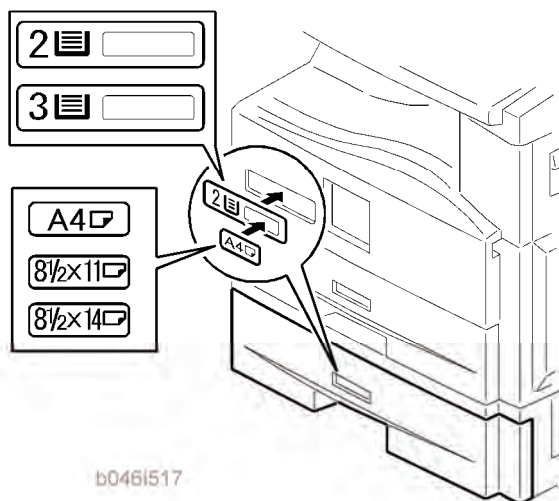

7. Stick on the appropriate tray-number decal(s) and paper-size decal(s), at the locations indicated in the illustration.

2.5 PAPER TRAY UNIT HEATER

The paper tray unit heater is installed only for the first paper tray unit.

2.5.1 ACCESSORY CHECK

Confirm that you have the accessories listed below.

Description	Q'ty
1. Grounding wire	1
2. Relay harness	1
3. Clamps	2
4. Ferrite core	1
5. Heater fastening screws	2
6. PTU fastening screws	3
7. Grounding screw	1
8. Decal for copier	1
9. Decal for paper tray unit	1
10. Tie wrap	1

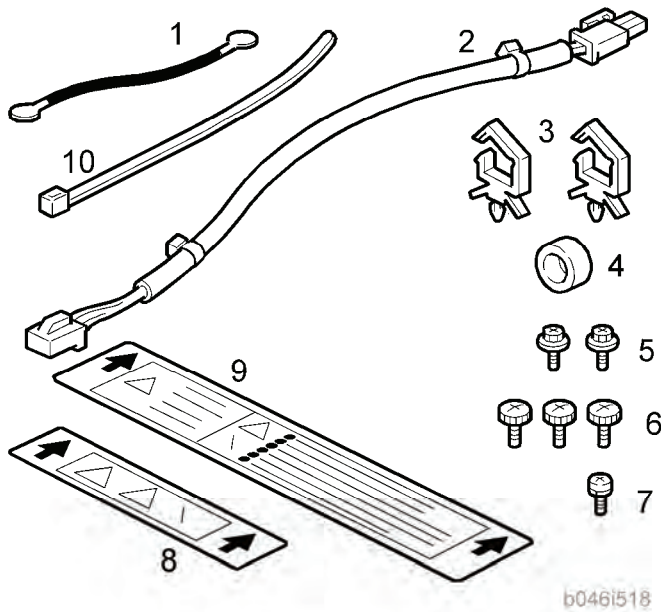

2.5.2 INSTALLATION PROCEDURE

⚠ CAUTION

- Unplug the main machine's power cord before starting the following procedure.
1. Remove the paper tray unit from the copier if it is already installed.
 2. Remove the paper trays from the copier and from the paper tray unit.

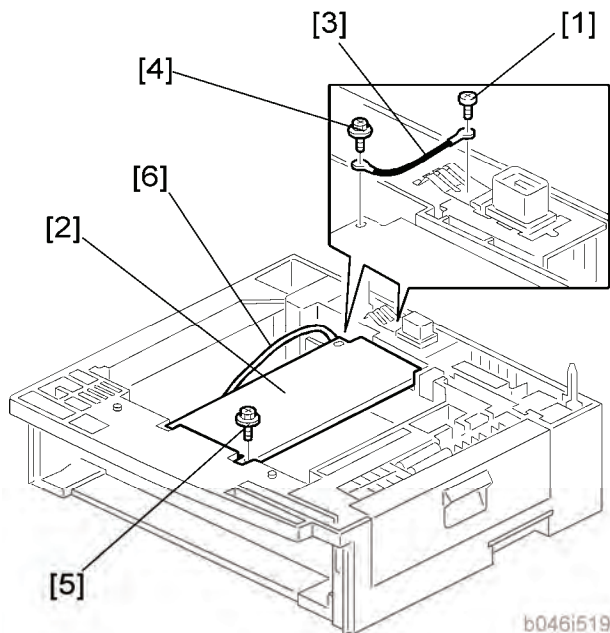

3. Remove the ground screw [1] at the rear of the paper tray unit.
4. Fasten the heater [2] and the supplied ground wire [3] to the paper tray unit ( x 3). Note that [1] is the ground screw you removed in the previous step and [4] and [5] are the two

Paper Tray Unit Heater

supplied heater fastening screws.

Note

- Be sure to position the ground wire [3] and heater harness [6] so that they are out of the way of the copier when you set it on the paper tray unit.

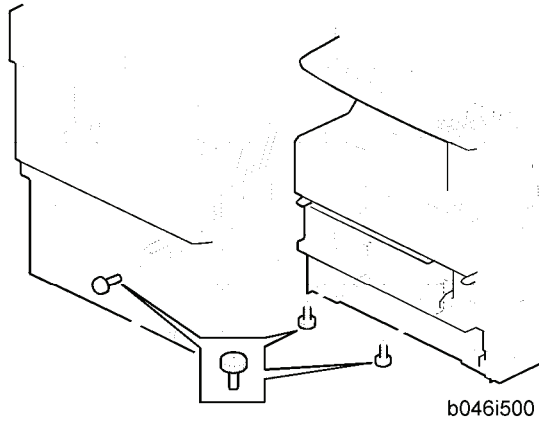

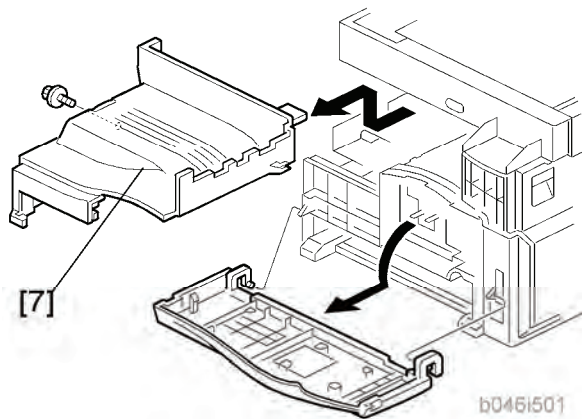

5. Set the copier on the paper tray unit.
6. Screw the paper tray unit into place using three supplied PTU fastening screws.



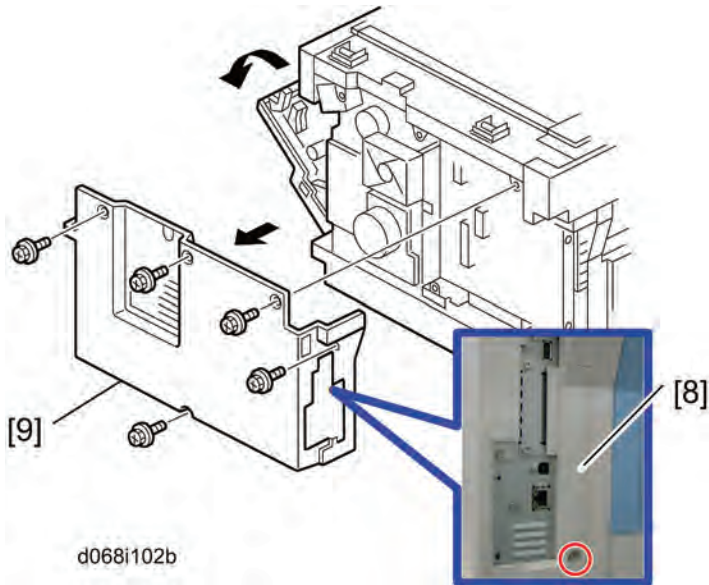

7. Open the front door and remove the copy tray [7] ( ×1).
8. Close the front door.

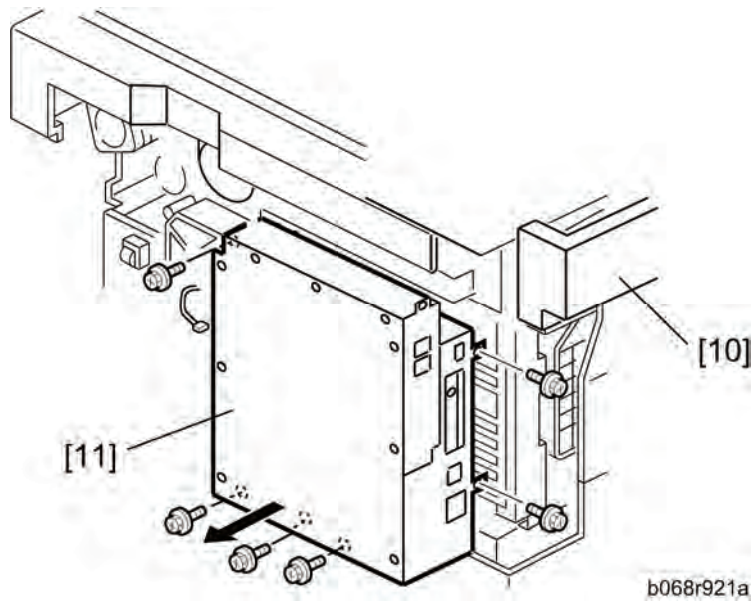

1. Open the right cover
2. Remove the interface cover [8] ( x 1).
3. Remove the rear cover [9] ( x 5).



4. Remove the upper left cover [10].
5. Remove the controller box [11] ( x 1,  x 6).

Paper Tray Unit Heater

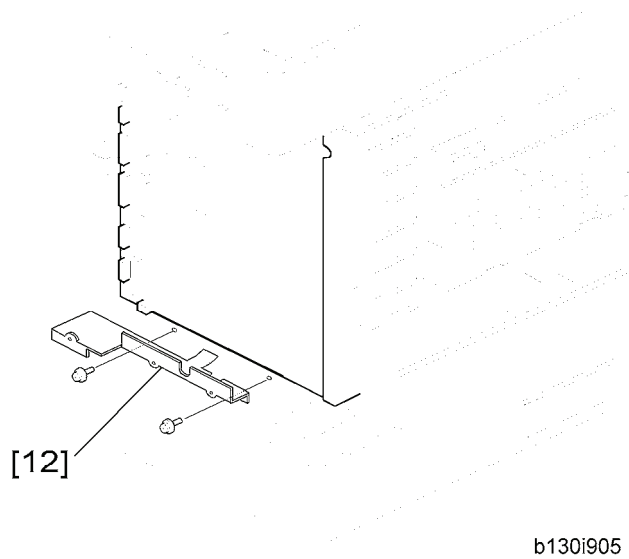

6. Remove the support bracket [12] ( x 3).

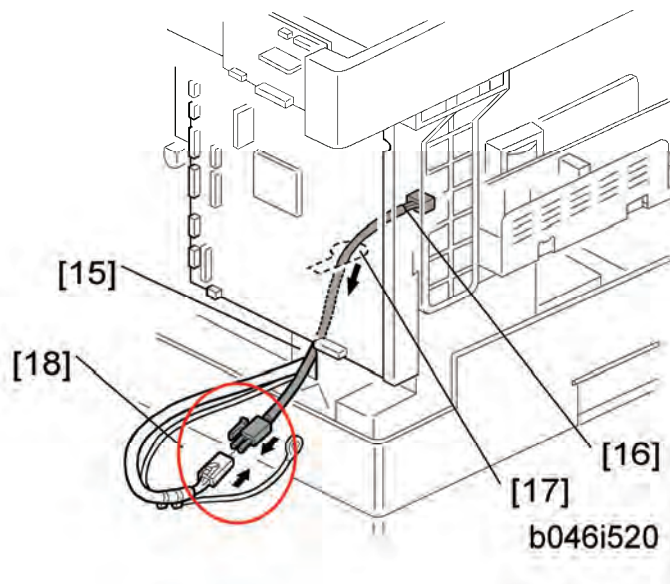

7. Pass the heater harness through the hole [15] at the rear of the copier.
8. Pass relay harness [16] through the opening [17] (at the rear of the PSU) and through the other opening [15].
9. Connect the relay harness to the heater's harness [18].

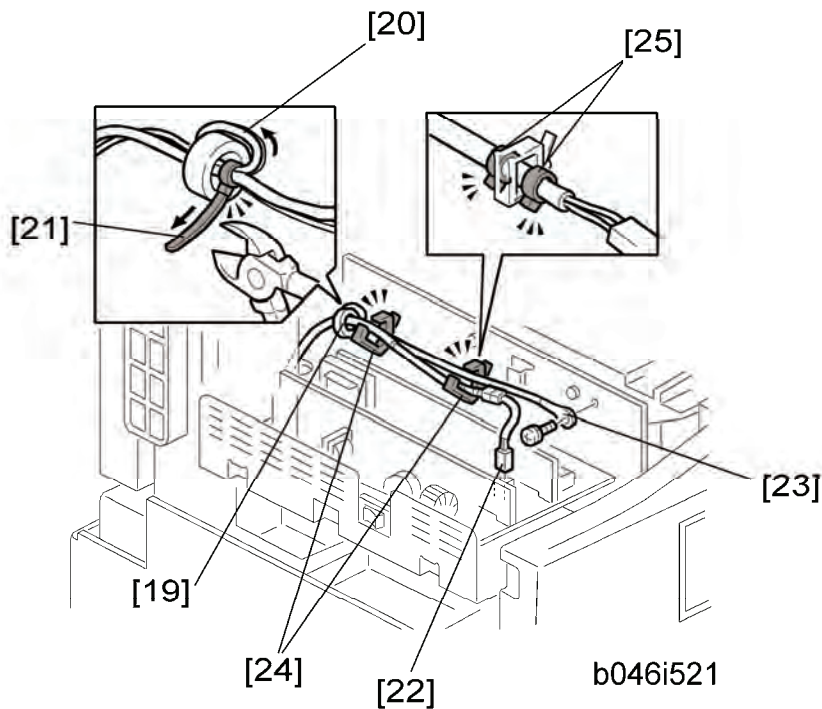

10. Pull the relay harness back into the copier.
11. Attach the ferrite core [19] over the relay harness.
12. Push the ferrite core back so that it is over the heater's harness.
13. Wrap the heater's harness once around the ferrite core [20].
14. Locate the ferrite core at the rear [24] of the copier behind the rear clamps.
15. Secure the ferrite core with the supplied tie wrap [21].
16. Clip off the excess length of the tie wrap.
17. Connect the relay harness connector [22] to the large connector at the front center of the PSU.
18. Screw the ground wire [23] to the PSU bracket with the included grounding screw.
19. Attach the clamps [24] to the PSU bracket.
20. Attach the heater harness through the clamps.
21. Position the harness so that the front clamp is between the two bindings [25] on the harness.
22. Fasten the clamps.

Paper Tray Unit Heater

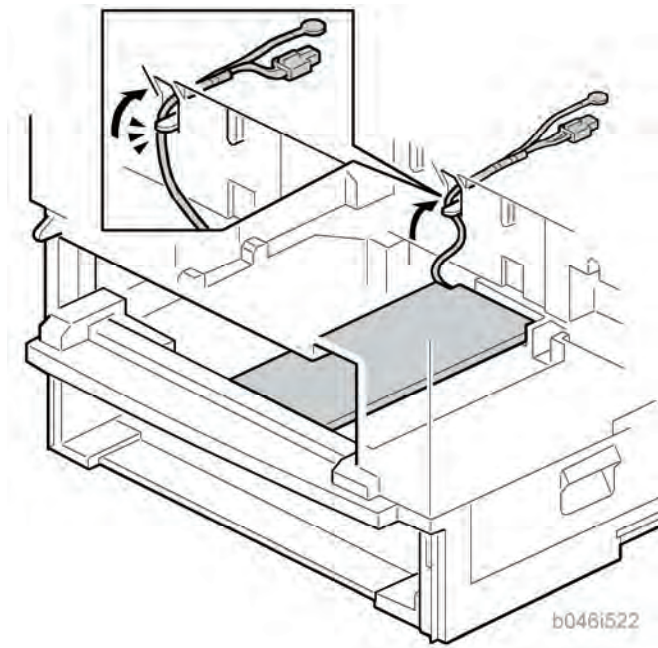

23. Pull the excess length of the heater's harness out the opening at the rear.

↓ Note

- Be sure that the harness passes on the side of the grounding plate at the bottom of the opening. (The front of the grounding plate must remain clear.)

24. Arrange the excess harness length so that it sits beneath the FCU cover plate.

25. Attach the caution decals to the locations shown in the illustration.

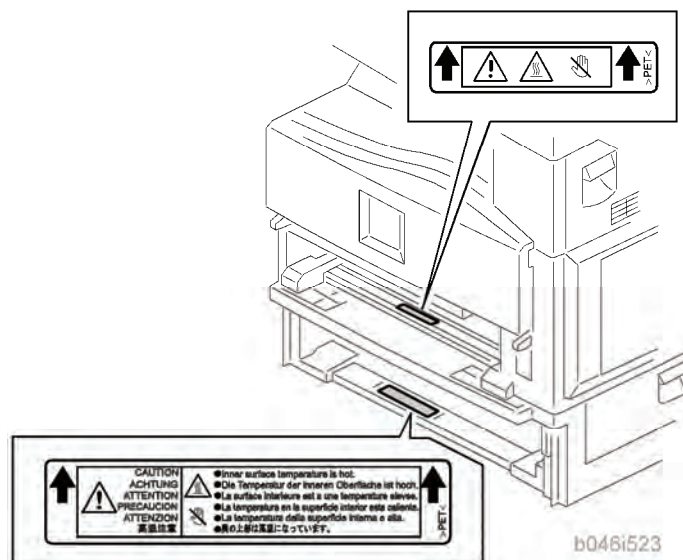

26. Reassemble the copier.

27. Plug in the power cord, and check the operation.

2.6 USB 2.0/SD SLOT TYPE B

This procedure explains how to install the USB 2.0/SD Slot for the SPF model (D115).

2.6.1 ACCESSORY CHECK

Check the quantity and condition of the accessories against the following list.

No.	Description	Q'ty
1	USB2.0/SD Slot	1
2	Ground Plate	1
3	USB Cable	1
4	Screw: M3 x 6 blue	1
5	Screw: M3 x 8	2
6	Screw:	1
7	Clamp	1
8	Decal	1

2.6.2 INSTALLATION PROCEDURE

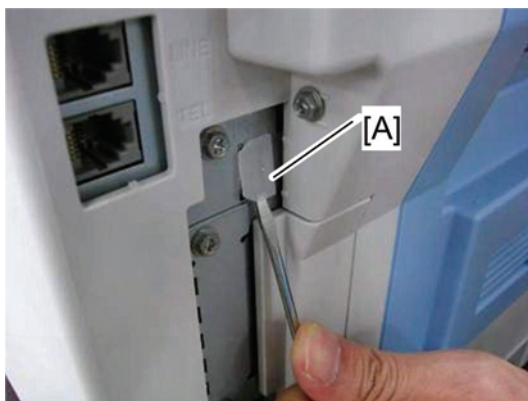

d068i001

1. Remove the USB connect cover [A].

USB 2.0/SD Slot Type B

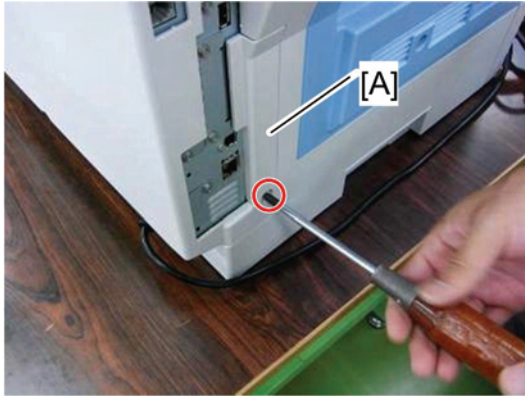

d068i002

2. Remove the interface cover [A].

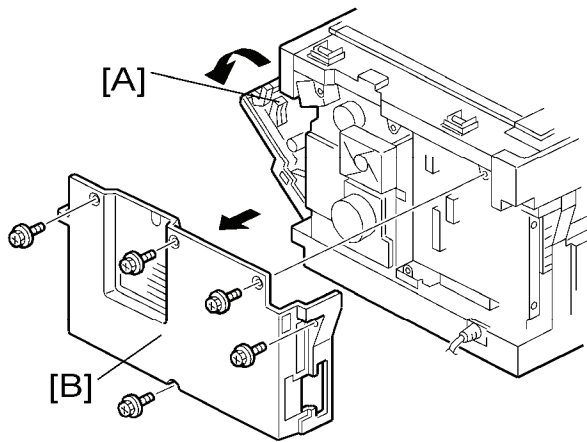

b284i102a

3. Open the right door [A].
4. Rear cover [B] ( x 5)



d068i003

5. Remove the upper left cover [A] as shown above.

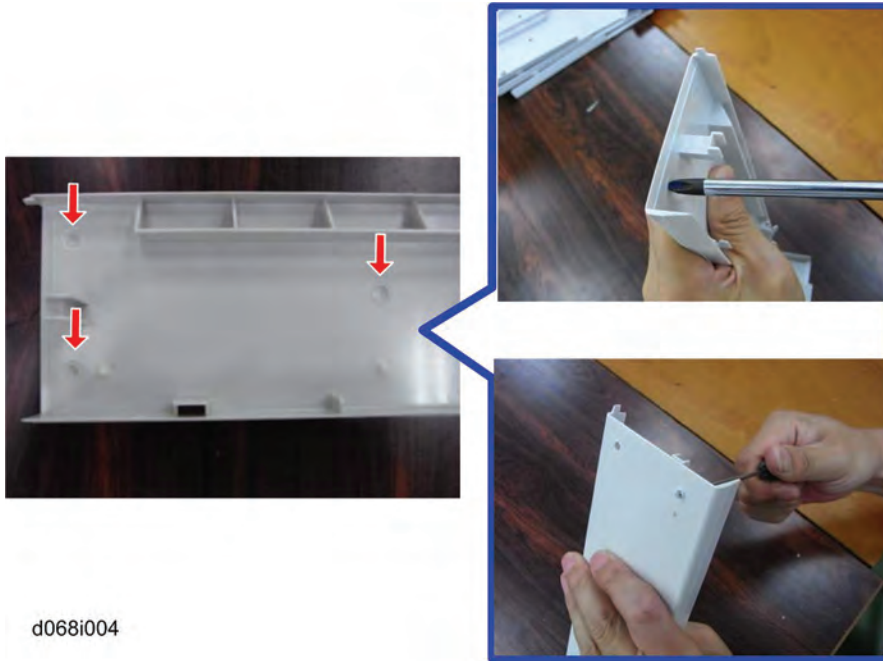



6. Make three holes in the upper left cover with a screwdriver as shown above.

Note

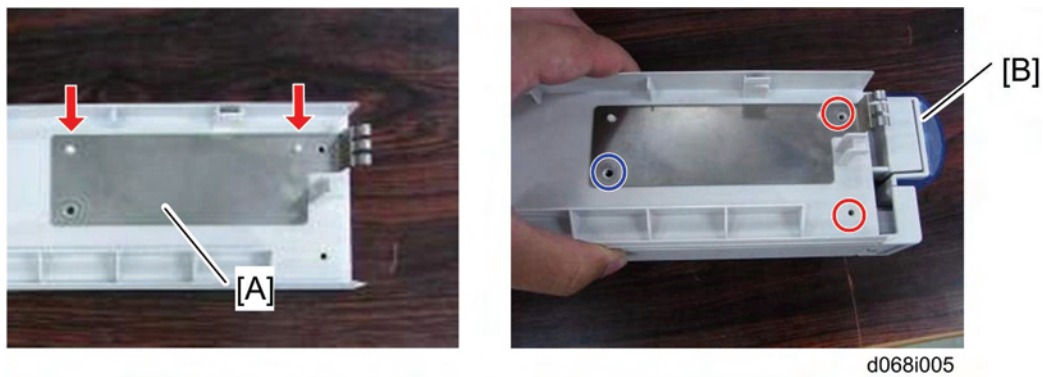
- Smooth the three holes in the upper left cover.



7. Attach the ground plate [A].

8. Secure the USB2.0/SD Slot [B] with the upper left cover as shown above ( x 1: M3 x 6 blue,  x 2: M3 x 8).

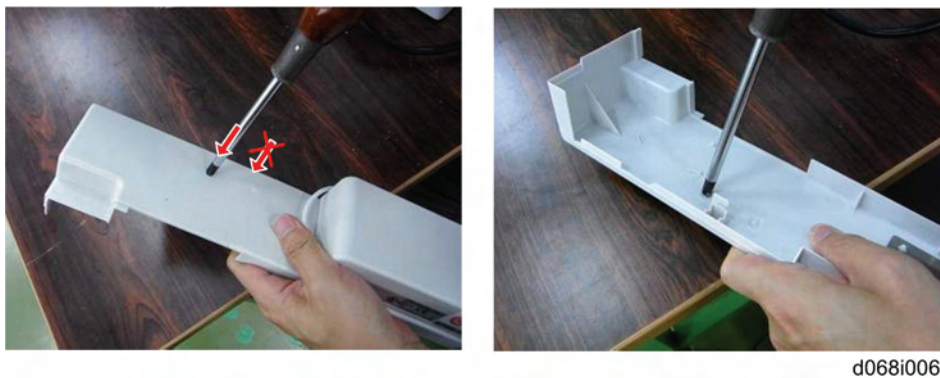

9. Make a clamp hole the upper left cover with a screwdriver as shown above.

USB 2.0/SD Slot Type B

↓ Note

- Smooth the hole in the upper left cover.



d068i007

10. Attach the upper left cover [A] to the mainframe.

11. Attach the rear cover.

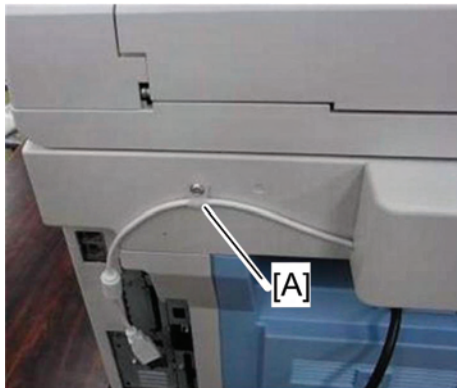

d068i008

12. Attach the cable clamp [A] to the upper left cover ( x 1) as shown above.

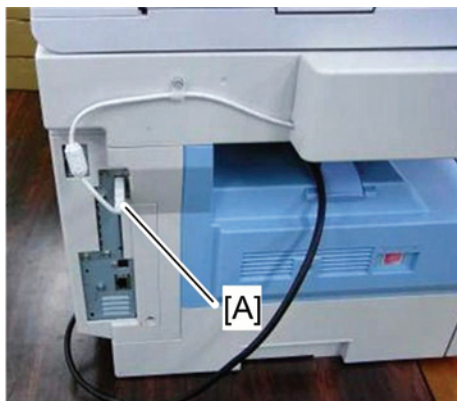

d068i009

13. Connect the USB cable [A] to USB-A.

14. Attach the interface cover.

15. Plug in and turn on the main machine.

16. Enter the SP mode, and then change the setting of SP1013-001 from "0" to "1".

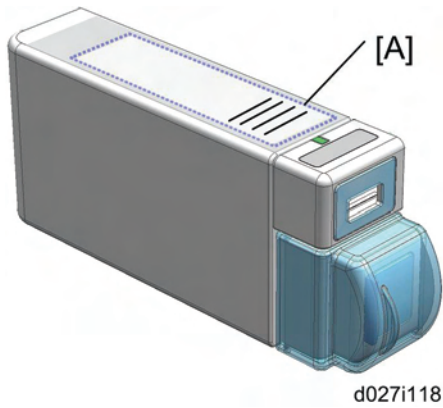

17. Attach the decal [A] to the USB2.0/SD Slot as shown above.

When Installing the Handset

1. Do steps 1 to 8 in “installation procedure”.



2. Make two holes the upper left cover with a screwdriver as shown above.

↓ Note

- Smooth the holes in the upper left cover.

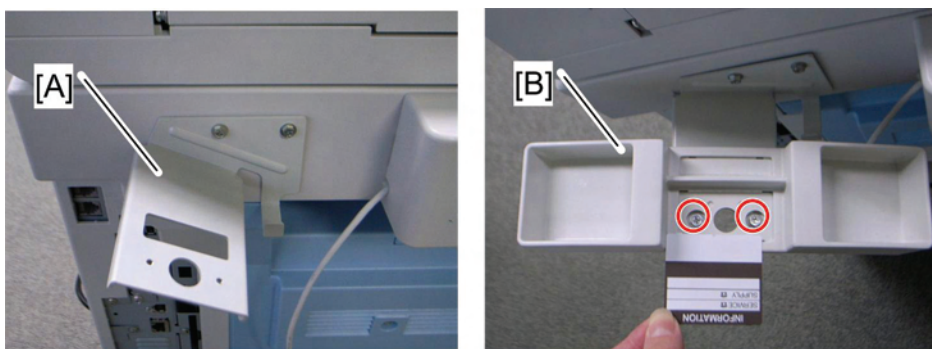

3. Attach the handset bracket [A] ( x 2)

4. Attach the cradle [B] to the handset bracket ( x 2)

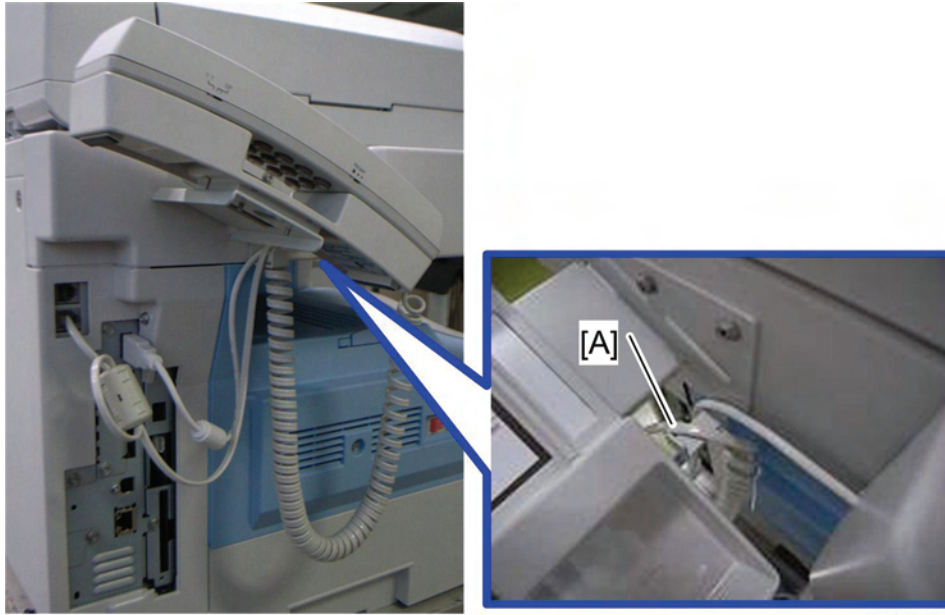

d068i013

5. Set the handset on the handset bracket.
6. Connect the handset cable to the “TEL” jack and set the telephone cable [A] as shown above.
7. Do steps 13 to 17 in “installation procedure”.

2.6.3 TESTING THE SD CARD/USB SLOT

1. Insert an SD card or USB memory device in the slot.
You can connect only one removable memory device at a time.
2. Close the media slot cover.
If you leave the cover open, static electricity conducted through an inserted SD card could cause the machine to malfunction.
3. Make sure that no previous settings remain.
If a previous setting remains, press the [Clear Modes] key.
4. Place an original on the exposure glass.
5. Press [Store File].
6. Press [Store to Memory Device].
7. Press [OK].
8. Press the [Start] key.
When writing is complete, a confirmation message appears.
9. Press [Exit].
10. Remove the memory device from the media slot.
Do not remove the memory device while writing is in process.

2.7 OPTIONAL PAPER TRAY GRIP HANDLE

The following procedure is for the paper tray for the main copier or optional paper tray unit.

2.7.1 ACCESSORIES

Check the accessories and their quantities against the table below.

No.	Description	Q'ty
1	Grip Handle	1
2	Screw (M3 x 10)	2

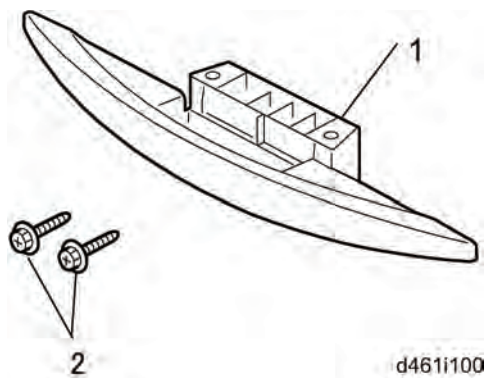

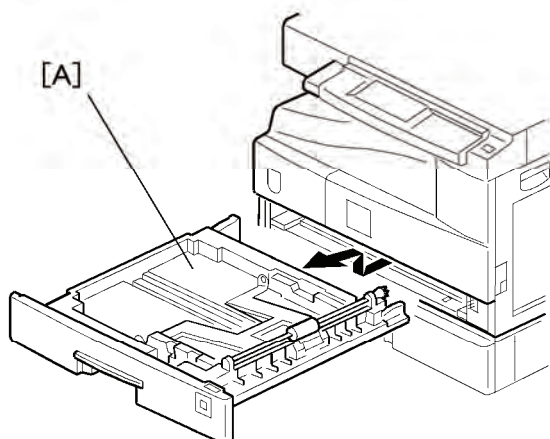

Installation Procedure

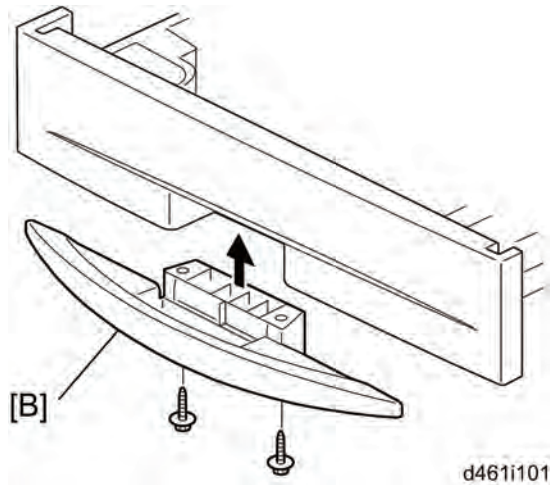

1. Remove the paper tray [A] from the main copier.

Optional Paper Tray Grip Handle



2. Turn the paper tray over to the opposite side.
3. Lower the paper tray grip handle [B] into the paper tray slot as shown, with the arrow in the above illustration.
4. Attach the grip handle to the paper tray ( x 2).

Note

- When attaching auxiliary handle (two screws attached from bottom), hold handle against front of paper drawer (as screws are tightened) to ensure there is ensure the smallest gap between back of handle and front of paper drawer.
5. Put the paper tray back into the machine.

2.8 CONTROLLER OPTIONS

2.8.1 OVERVIEW

This machine has I/F card slots and SD card slots for optional I/F connections and applications.

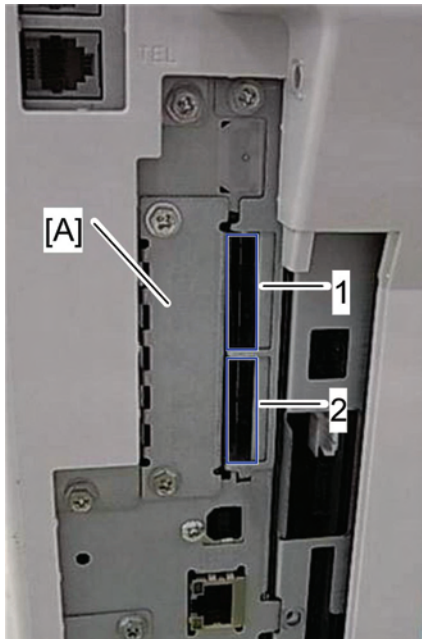

d068i014

I/F Card Slot

- Slot [A] is used for one of the optional I/F connections: (IEEE1284, IEEE802.11a/g (Wireless LAN) or Gigabit Ethernet).

SD Card Slot

- Slot [1] is used for options provided on SD cards. The application SD card (Printer/Scanner or Security Card) should be installed in Slot 1. If more than one application is to be used, move the applications to the same SD card with SP5873.
- Slot [2] is used for options provided on SD cards and servicing. The VM card must be installed in Slot 2.

2.8.2 WIRELESS LAN (IEEE 802.11A/G) INSTALLATION

CAUTION

- Unplug the machine power cord before starting the following procedure.

Accessories



Check the accessories and their quantities against the table below.

No.	Description	Q'ty
1	Wireless Adapter	1
2	Wireless LAN Card	1
3	LAN Card Cover	4
4	Caution Sheet	1
5	Label	1

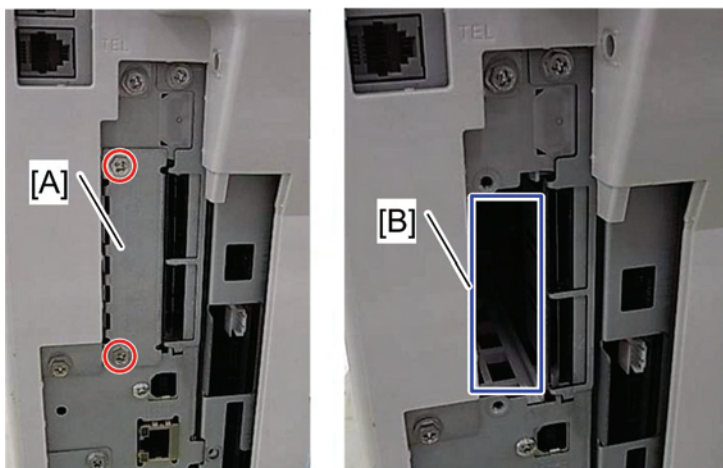
Installation Procedure



d068i017

1. Remove the interface cover [A] ( x 2).
2. Install the Wireless adaptor into I/F slot [B] ( x 2).
3. Install the Wireless LAN card in the wireless adaptor.
4. Attach the antenna cap to the wireless LAN card.
5. Turn on the main power switch.
6. Print out the configuration page (User Tools/Counter > Printer Features > List/Test Print),

and then check that this device is detected.

If reception is poor, you may need to move the machine:

- Make sure that the machine is not located near an appliance or any type of equipment that could generate a strong magnetic field.
- Position the machine as close as possible to the access point.

SP Mode Settings for IEEE 802.11a/g Wireless LAN

The following SP commands can be set for IEEE 802.11a/g

SP No.	Name	Function
5840 004	SSID	Used to confirm the current SSID setting.
5840 006	Channel MAX	Sets the maximum range of the channel settings for the country.
5840 007	Channel MIN	Sets the minimum range of the channel settings allowed for your country.
5840 011	WEP Key Select	Used to select the WEP key (Default: 00).
5840 018	SSID Check	Used to check the SSID.
5840 020	WEP Mode	Used to display the maximum length of the string that can be used for the WEP Key entry.

2.8.3 IEEE 1284 INSTALLATION

⚠ CAUTION

- Unplug the machine power cord before starting the following procedure.

Accessories

Check the accessories and their quantities against the table below.

No.	Description	Q'ty
1	IEEE1284 Interface Ass'y	1
2	UL Sheet	1
3	Caution Sheet	1

Installation Procedure

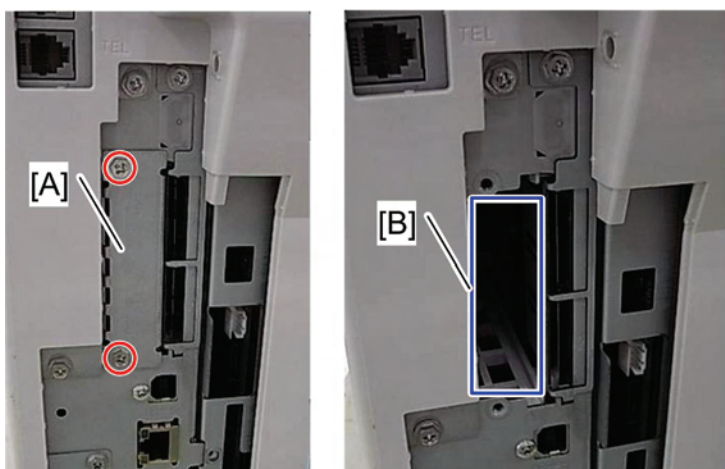

d068i017

1. Remove the interface cover [A] (⚙ x 2).
2. Install the IEEE 1284 board into I/F slot [B] (⚙ x 2).
3. Turn on the main power switch.
4. Print out the configuration page (User Tools/Counter > Printer Features > List/Test Print), and then check that this device is detected.

2.8.4 VM CARD TYPE L (D467)

Accessories

Check the accessories and their quantities against the table below. Accessories

No.	Description	Q'ty
1	VM SD Card	1
2	Decal	1

Installation

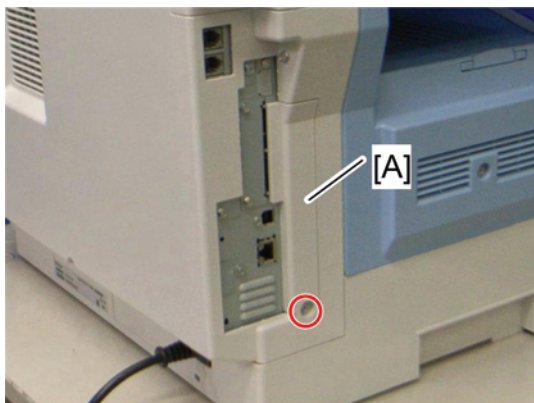

d115i020

1. Remove the interface cover [A] ( x 1).

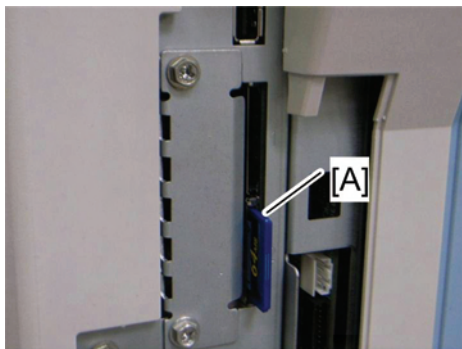

d068i019

2. Switch the machine off.
3. Insert the SD card [A] into SD Slot 2 (lower).

★ Important

- This SD card must be inserted into Slot 2, the lower slot.

2.8.5 GIGABIT ETHERNET

⚠ CAUTION

- Unplug the main machine power cord before you do the following procedure.

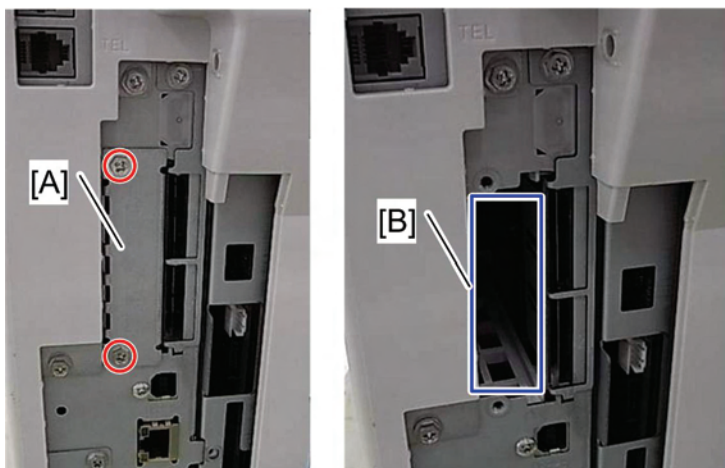

d068i017

1. Remove the I/F-slot cover [A] ( x 2).
2. Install the Gigabit Ethernet board (Knob-screw x 2) into the I/F-slot [B].

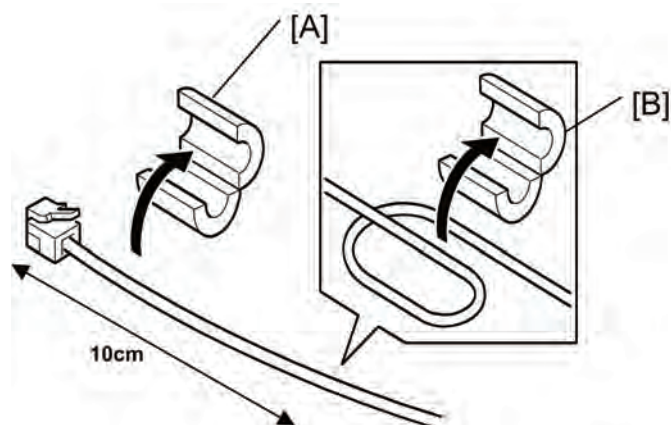

d067r113

3. Attach one ferrite core [A] to the Ethernet interface cable, and then attach the other ferrite core [B] about 10cm from the end of the Ethernet interface cable.
 4. Connect the Ethernet interface cable to the Gigabit Ethernet port.
- Make sure that the machine can recognize this option (see 'Check All Connections' at the end of this section).

2.8.6 HDD OPTION (D577)

Component Check

No.	Description	Q'ty
1	HDD Unit	1
2	Screw	3
3	Security Card	1
-	EMC Caution Sheet	1

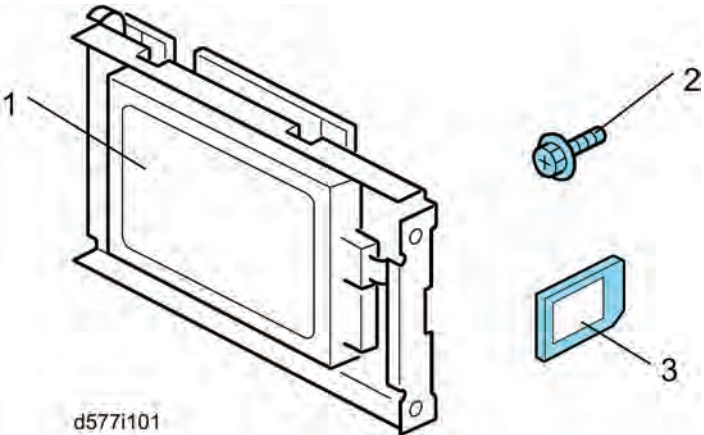

Installation

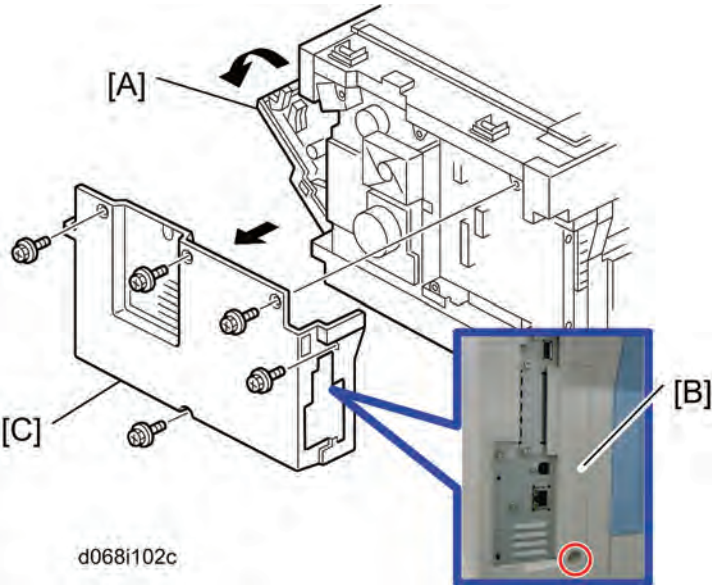

Installation Procedure



Controller Options

1. Open the right door [A].
2. Interface cover [B] ( x 1)
3. Rear cover [C] ( x 5)

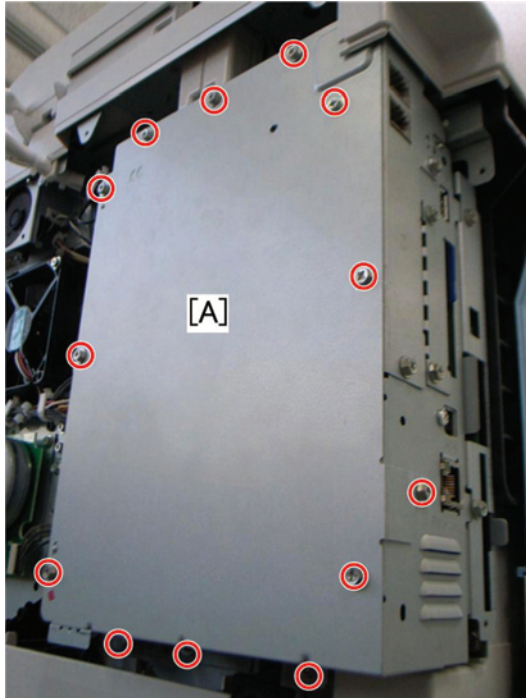

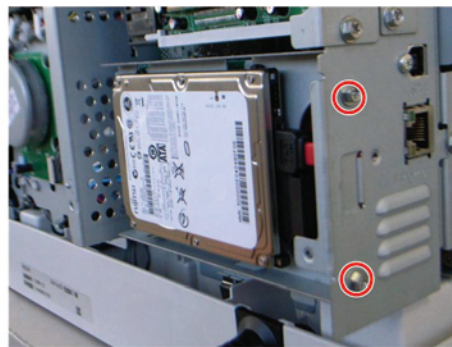
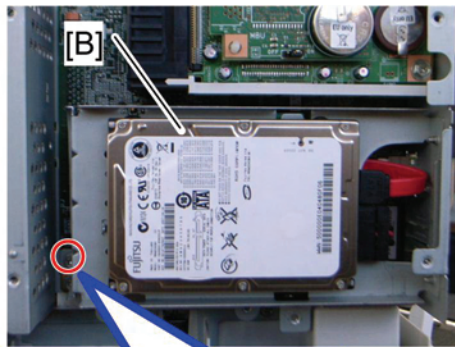

d068r025

4. Controller box cover [A] ( x 13)

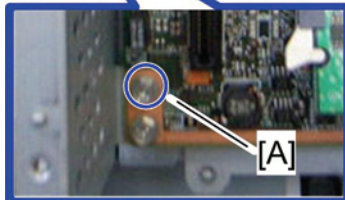

d068r028



5. Remove the screw [A] on the controller board.
6. Install the HDD unit [B] in the controller board ( x 3).

 Note

- The screw [A] is used in this step.

7. Reinstall the controller box cover and rear cover in the machine.

After Installing the HDD

1. Do **SP5832-001** to format the hard disk.
2. Do **SP5853-001** to copy the preset stamp data from the firmware to the hard disk.
3. Do **SP5846-040** to copy the address book to the hard disk from the controller board.
4. Do **SP5846-041** to let the user get access to the address book.
5. Turn the main power switch off/on.

Installing the Security Card

1. Insert the Security Card in the SD slot.
 - **For D115**, use slot 2 (lower) and merge the Security Card into the Printer/Scanner card with SP5-873-001. Remove the Security Card from the SD slot 2 after moving the security applications and keep the Security Card at a safe location.
 - **For D116**, use slot 1 (upper).
2. Enter the SP mode.
3. Input a machine serial number with SP 5811-001.
4. Go into the SP mode and push "EXECUTE" with SP5-878-001.
5. Select SP5878-002, and then press "Execute" on the LCD.
6. Exit the SP mode after "Completed" is displayed on the LCD.

Activating the Security Applications

1. Make sure that the following settings are not at their factory default values:

- Supervisor login password
- Administrator login name
- Administrator login password

If any of these settings is at a factory default value, tell the customer these settings must be changed before you do the installation procedure.

2. Make sure that “Admin. Authentication” is ON.

[System Settings] – [Administrator Tools] – [Administrator Authentication Management] -
[Admin. Authentication]

If this setting is OFF, tell the customer this setting must be ON before you do the installation procedure.

3. Make sure that “Administrator Tools” is enabled (selected).

[System Settings] – [Administrator Tools] – [Administrator Authentication Management] -
[Available Settings]

If this setting is disabled (not selected), tell the customer this setting must be enabled (selected) before you do the installation procedure.

4. Refer to the Security Reference for details about activating the security applications (HDD Encryption Unit and DataOverwriteSecurity).

HDD Encryption Recovery from a Device Problem

The flowchart below shows the recovery possibility of the HDD encryption if one of devices related with the HDD encryption is defective.

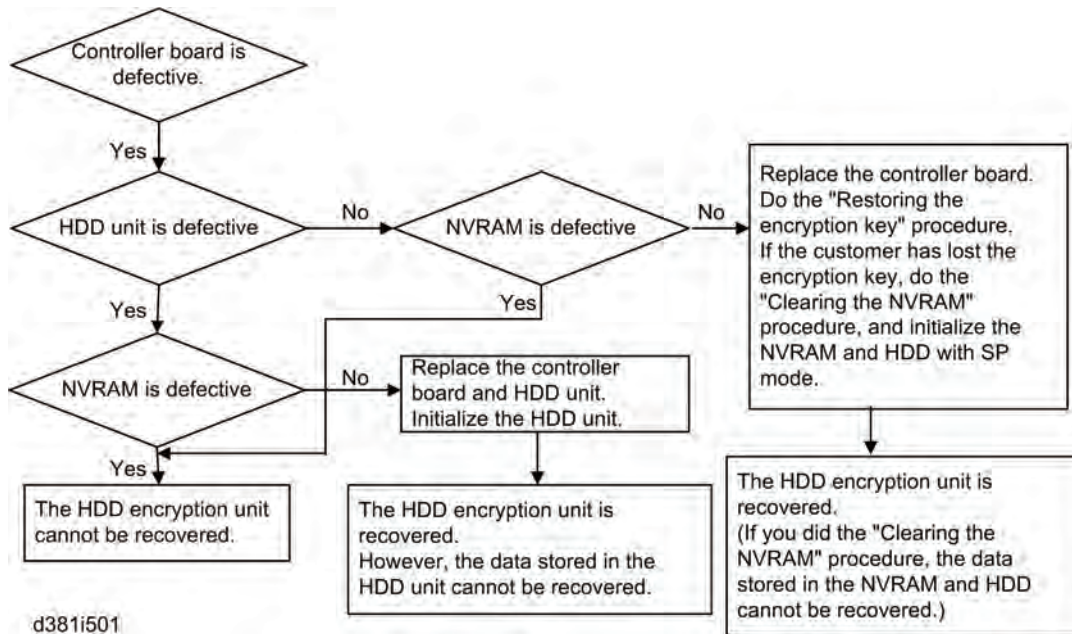

d381i501

Installation

Restoring the Encryption key

When replacing the controller board for a model in which the HDD encryption unit has been installed, updating the encryption key is required.

1. Prepare an SD card which is initialized.
2. Make the "restore_key" folder in the SD card.
3. Make an "nvram_key.txt" file in the "restore_key" folder in the SD card.
4. Ask an administrator to input the encryption key (this has been printed out earlier by the user) into the "nvram_key.txt" file.
5. Remove only the HDD unit (HDD).
6. Turn on the main power switch.
7. Confirm that the prompt on the LCD tells you to install the SD card (storing the encryption key) in the machine.
8. Turn off the main power switch.
9. Insert the SD card that contains the encryption key into slot 1.
10. Turn on the main power switch, and the machine automatically restores the encryption key in the flash memory on the controller board.
11. Turn off the main power switch after the machine has returned to normal status.
12. Remove the SD card from slot 1.
13. Reinstall the HDD unit.

Clearing the NVRAM

When replacing the controller board for a model in which the HDD encryption unit has been installed and a customer has lost the encryption key, clearing the NVRAM is required to recover the HDD encryption unit.

1. Prepare an SD card which is initialized.
2. Make the "restore_key" folder in the SD card.
3. Make an "nvram_key.txt" file in the "restore_key" folder in the SD card.
4. Input "nvclear" into the "nvram_key.txt" file.
5. Turn on the main power switch.
6. Confirm that the prompt on the LCD tells you to install the SD card (storing the encryption key) in the machine.
7. Turn off the main power switch.
8. Insert the SD card that contains "nvclear" into slot 1.
9. Turn on the main power switch, and the machine automatically restores the encryption key in the flash memory on the controller board.
10. Turn off the main power switch after the machine has returned to normal status.
11. Remove the SD card from slot 1.
12. Turn on the main power switch.
13. Initialize the NVRAM (SP5801-001) and HDD unit (SP5832-001) with SP mode.
14. The user must enable the HDD encryption unit with a user tool.

PREVENTIVE MAINTENANCE

REVISION HISTORY		
Page	Date	Added/Updated/New
		None

3. PREVENTIVE MAINTENANCE

3.1 MAINTENANCE TABLES

See "Appendices" for the following information:

- PM tables

3.2 HOW TO CLEAR THE PM COUNTER

Reset the PM counter after your maintenance work.

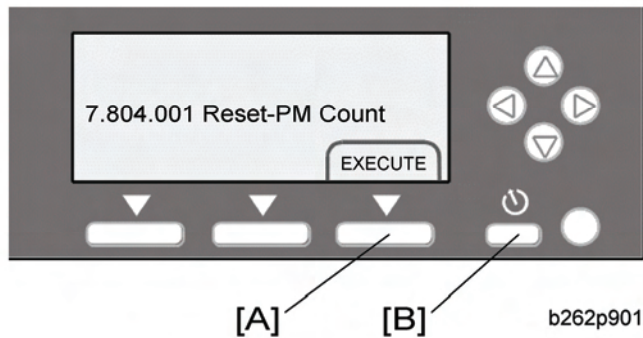

1. Activate the SP mode.
2. Select SP7-804-001.
3. Press the EXECUTE key [A]. The message "Completed" is displayed when the program ends normally. An error message is displayed if the program ends abnormally.
4. Press the Escape key [B] to end the program.

REPLACEMENT AND ADJUSTMENT

REVISION HISTORY		
Page	Date	Added/Updated/New
		None

4. REPLACEMENT AND ADJUSTMENT

4.1 PRECAUTIONS

4.1.1 GENERAL

CAUTION

- Turn off the main power switch and unplug the machine before starting replacement. Before turning off the main power switch, check that no mechanical component is operating. Mechanical components may stop out of their home positions if you turn off the main power switch while they are operating. The component may be damaged if you try to remove it when it is not in the home position.

4.1.2 LITHIUM BATTERIES

CAUTION

- Incorrect replacement of lithium battery(s) on the controller or on the fax unit poses risk of explosion. Replace only with the same type or with an equivalent type recommended by the manufacturer. Discard used batteries in accordance with the manufacturer's instructions.

4.1.3 HALOGEN-FREE CABLE

CAUTION

- Use extreme caution while handling cables.

To comply with local regulations, halogen-free cables are used in this machine. Halogen-free cables are environment-friendly, but no stronger than conventional cables. These cables may be damaged in any of the following cases:

- The cable is caught between hard objects such as brackets, screws, PCBs, and exterior covers.
- The cable is rubbed on a hard object such as brackets, screws, PCBs, and exterior covers.
- The cable is scratched with a hard object such as brackets, screws, PCBs, exterior covers, screwdrivers, and fingernails.

4.1.4 STATIC ELECTRICITY

Always touch a grounded surface to discharge static electricity from your hands before you handle SD cards, printed circuit boards, or memory boards.



4.2 SPECIAL TOOLS AND LUBRICANTS

Part Number	Description	Q'ty
A1849501	Optics Adjustment Tools (2 pcs/set)	1 set
A2929500	Test Chart – S5S (10 pcs/set)	1 set
VSSM9000	Digital Multimeter – Fluke 87	1
N8036701	Flash Memory Card (4MB)	1
N8031000	Case for Flash Memory Card	1
A2579300	Grease Barrierta – S552R	1
52039502	Silicon Grease 501	1

4.3 EXTERIOR COVERS AND OPERATION PANEL

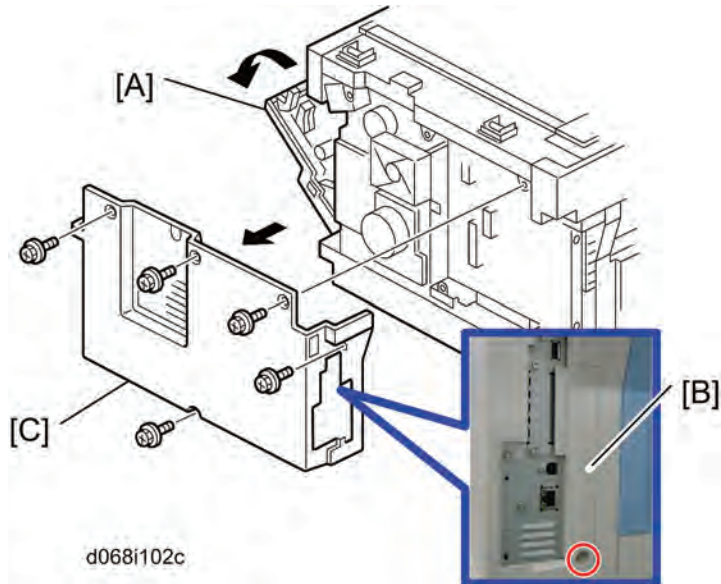
4.3.1 REAR COVER





1. Open the right door [A].
2. Interface cover [B] ( x 1)
3. Open the right door [A].
4. Rear cover [C] ( x 5)

4.3.2 COPY TRAY

CAUTION

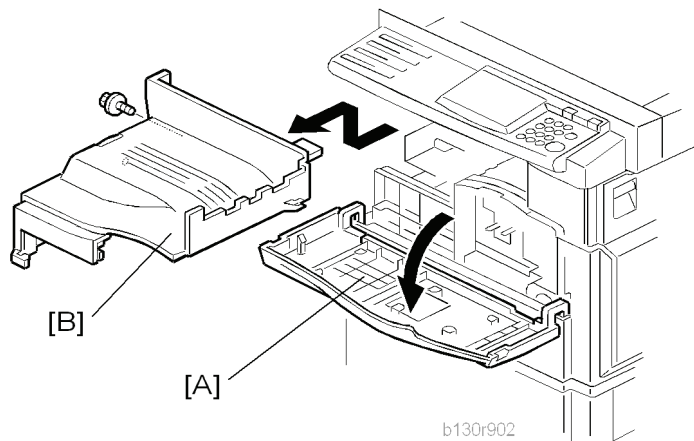
- Make sure that the cables under the copy tray are in place before reassembling the copier. If these cables are caught between the copy tray and the inner cover, they may be severely damaged.



1. Open the front door [A].
2. Copy tray [B] ( x1)

Reassembling:

There are several cables under the front end of the copy tray. To set these cables in place, gently pull these cables to the left-hand side (toward the PSU) and hold them there as you attach the copy tray.

4.3.3 OPERATION PANEL AND UPPER COVERS

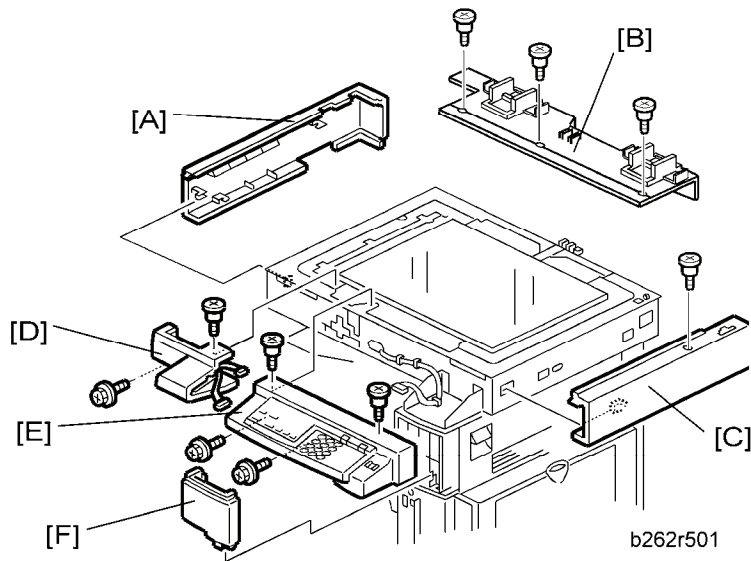

1. Remove the ARDF.
2. Rear cover (p.4-3)
3. Slide the upper left cover [A] to the rear.
4. Rear scale [B] (x 3)
5. Slide the upper right cover [C] to the rear.
6. Front left cover [D] (x 2)
7. Operation panel [E] (x 4, x 1)
8. Front right cover [F]

4.3.4 RIGHT DOOR

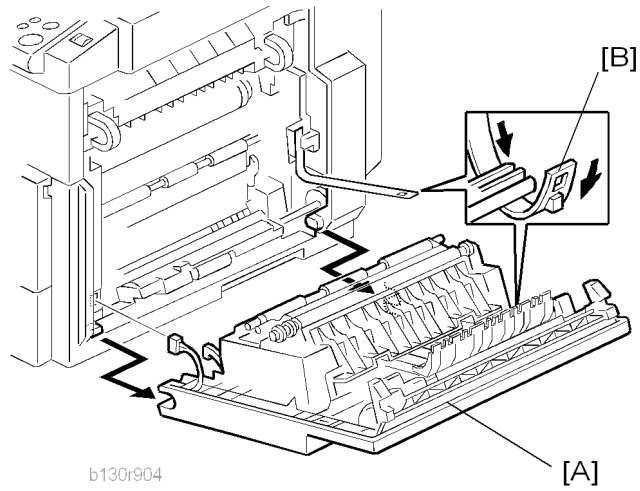

1. Open the right door [A].
2. Release the strap [B].
3. Right door (📄 x 1)

4.3.5 BYPASS TRAY

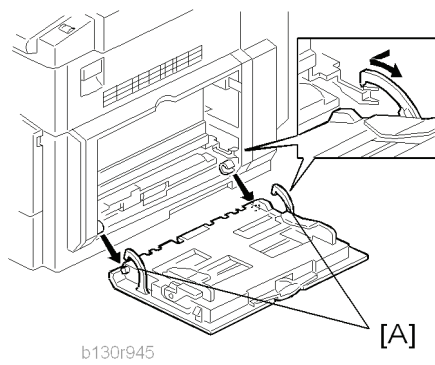

1. Press the stopper rails [A] inward.

4.3.6 PLATEN COVER SENSOR

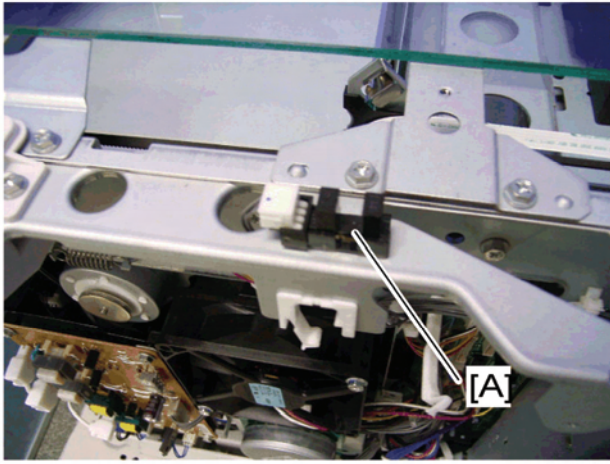

1. Rear cover (🔧 p.4-3)
2. Rear scale (🔧 p.4-5 "Operation Panel and Upper Covers")
3. Platen cover sensor [A] (🔧 x 1, hook)

4.4 SCANNER UNIT

To clean the mirrors and lenses, use a blower brush or wet cotton.

4.4.1 EXPOSURE GLASS

To clean the exposure glass, use alcohol or glass cleaner.

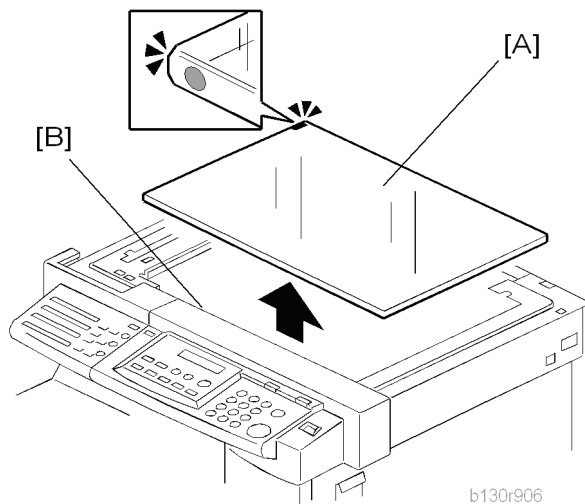

1. Rear cover (☛ p.4-3)
2. Rear scale, upper right cover (☛ p.4-5 "Operation Panel and Upper Covers")
3. Exposure glass [A]

Reassembling

Make sure that the marking on the glass is at the rear left corner, and that the left edge of the glass is aligned flush against the support ridge [B] on the frame.

Adjustment

When replacing the white plate, perform the "Scan Auto Adjustment" (☛ SP4-428-001).

4.4.2 LENS BLOCK

⚠ CAUTION

- Do not disassemble the lens block. The lens block is precision adjusted before shipment.
- Do not touch the screws on the CCD. The CCD is precision adjusted before shipment.

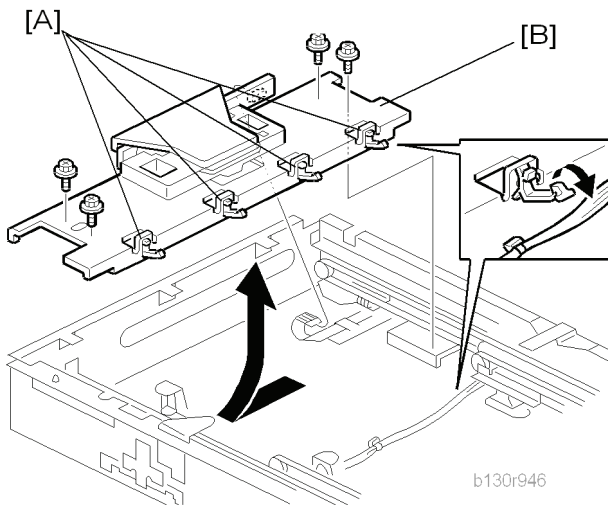

1. Exposure glass (☛ p.4-8)
2. Front left cover, operation panel (☛ p.4-5 "Operation Panel and Upper Covers")
3. Release the cable from the four clamps [A].
4. Lens block [B] (☛ x 4, 1 flat cable)

↓ Note

- Do not loosen the paint-locked screws holding the lens unit in place.
- After installing a new lens block, carry out copy adjustments (☛ p.4-60 "Adjusting Copy Image Area").

4.4.3 EXPOSURE LAMP, LAMP STABILIZER BOARD

Do not fold the exposure cable on the exposure lamp.

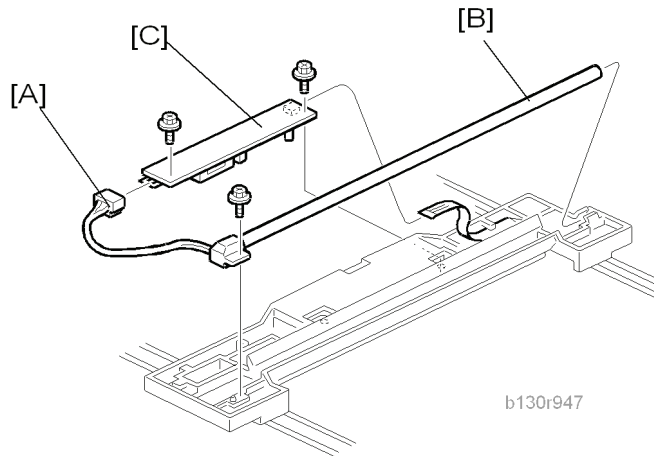

1. Exposure glass (🔧 p.4-8)
2. Front left cover, operation panel (🔧 p.4-5 "Operation Panel and Upper Covers")
3. Slide the first scanner to a position where the lamp and scanner are clear of the metal lids.
4. Disconnect the lamp connector [A].
5. Remove either or both of the following:
 - Exposure lamp [B] (🔧 x 1)
 - Lamp stabilizer board [C] (🔧 x 2, 1 flat cable)

4.4.4 SCANNER MOTOR

1. Rear cover (p.4-3)
2. Rear scale, upper right cover (p.4-5 "Operation Panel and Upper Covers")

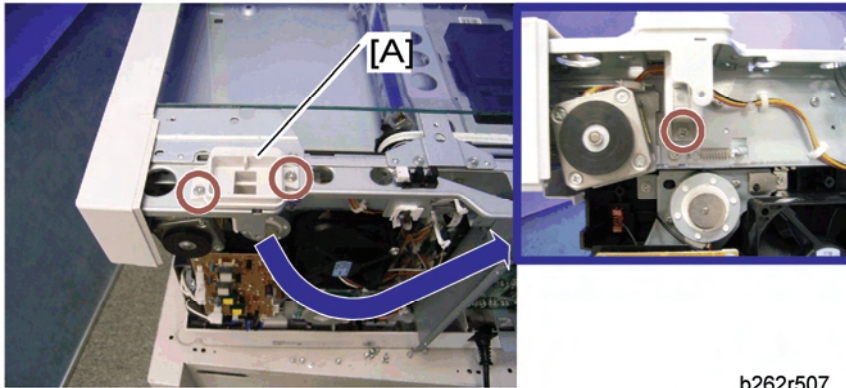

3. Remove the right platen stay holder [A] (x 3).

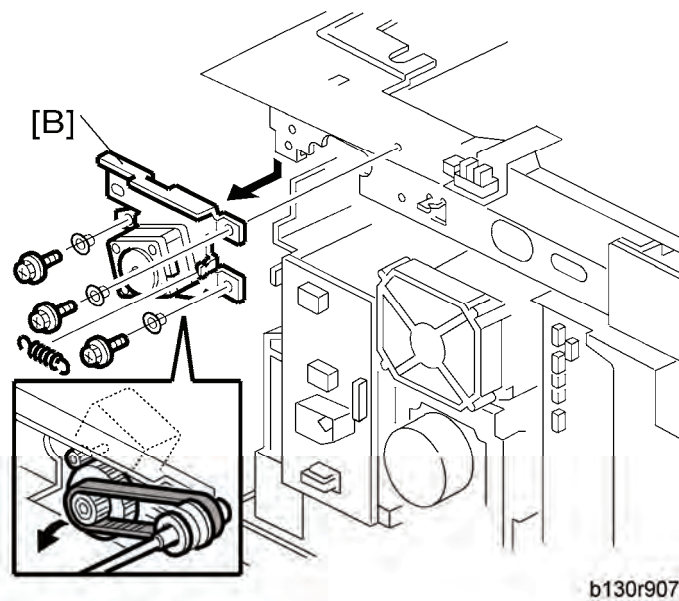

4. Scanner motor [B] (x 3, 1 spring, 3 screw holders, x 1)

Reinstalling

When reinstalling, fasten the screws loosely, set the spring in place, and tighten up the screws.

4.4.5 SCANNER HP SENSOR

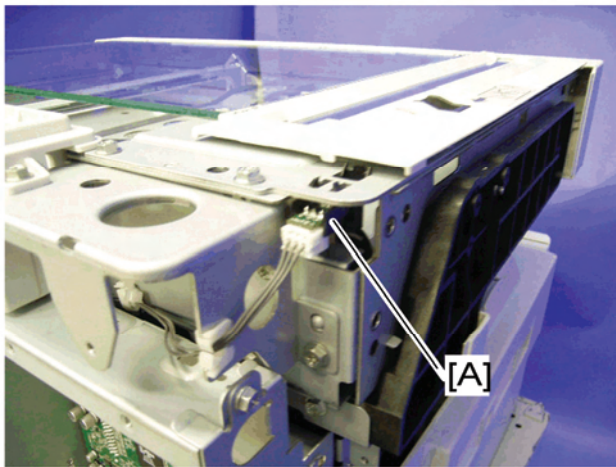

b262r506

1. Rear cover (🔧 p.4-3)
2. Front left cover (🔧 p.4-5 "Operation Panel and Upper Covers")
3. Scanner HP sensor [A] (🔧 x 1, hook)

↓ Note

- Move the first scanner from the home position if you have difficulty removing the sensor.

4.4.6 SCANNER ALIGNMENT ADJUSTMENT

1. Rear cover (🔧 p.4-3)
2. Rear scale, upper right cover, front left cover, operation panel (🔧 p.4-5 "Operation Panel and Upper Covers")
3. Exposure glass (🔧 p.4-8)
4. Loosen the 2 screws holding the 1st and 2nd scanner belts in place.

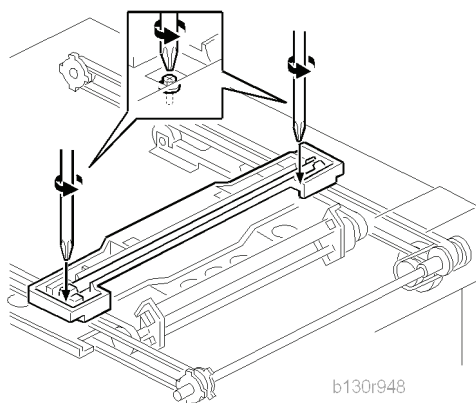

b130r948

5. Slide the 1st and 2nd scanners so that all four of the following are roughly aligned on both

the front and back sides:

- The hole in the copier's lid
- The hole in the 1st scanner
- The right corner hole in the 2nd scanner
- The hole at the base of the scanner

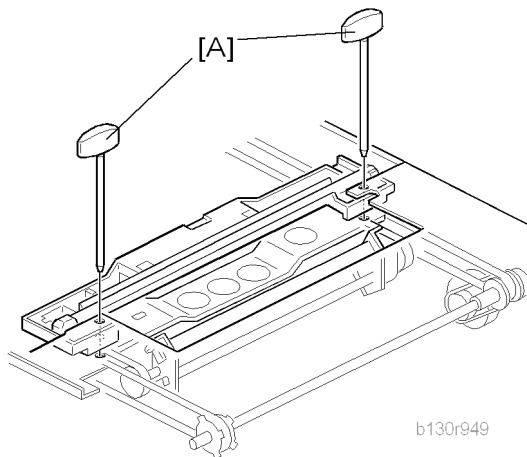

6. Insert the two optics adjustment tools [A], and adjust the scanners as necessary so that the tools go through all four holes.
7. Tighten the two screws that you loosened at step 2 above, so that the belts are firmly clamped into place.
8. Remove the adjustment tools.

4.5 FUSING



4.5.1 FUSING UNIT

CAUTION

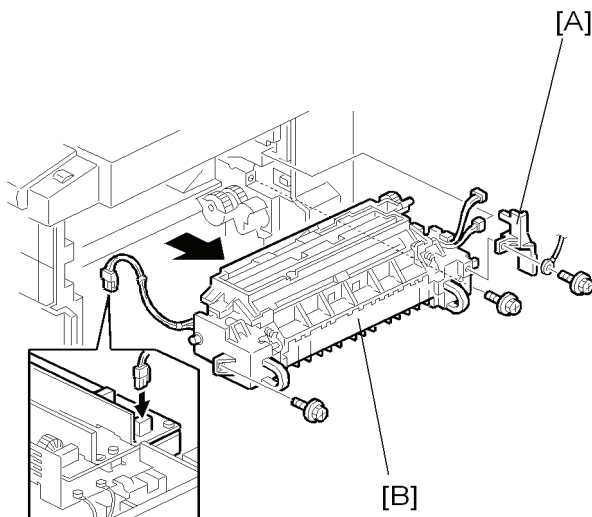
- Before handling the fusing unit, make sure that the unit is cool enough. The fusing unit can be very hot.





b130r950

1. Copy tray ( p.4-4)
2. Open the right door.
3. Connector cover [A] ( x 1)

Note

- When reinstalling, attach the ground wire.

4. Fusing unit [B] ( x 2,  x 4)

4.5.2 EXIT SENSOR

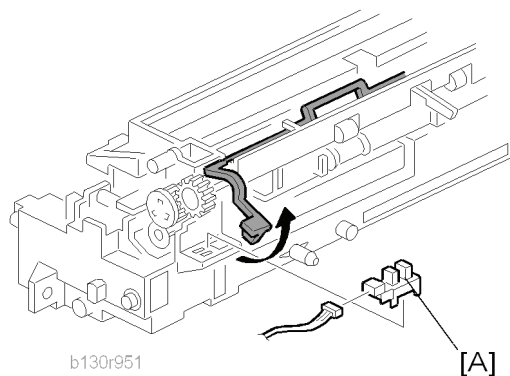

1. Fusing unit (☞ p.4-14)
2. Exit sensor [A] (☞ x 1)

4.5.3 HOT ROLLER STRIPPER PAWLS



- Take care not to damage the hot roller stripper pawls and the tension springs.

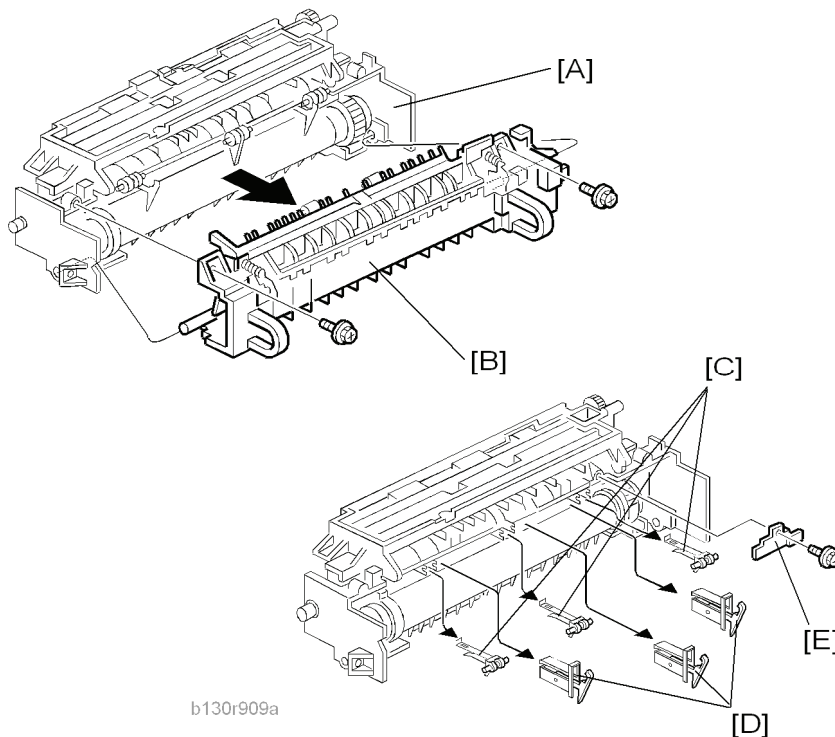

- Fusing unit (p.4-14)
- Separate the fusing unit into two sections: the hot roller section [A] and the pressure roller section [B] (x 2).

After removing the screws, lower the pressure roller section about halfway and then slide it toward the front side to detach it.

- Support rollers [C]
- Hot roller stripper pawls [D]



- Remove the spacer [E] (x 1) if you are removing the hot roller assembly (p.4-17 "Hot Roller and Fusing Lamp").

4.5.4 HOT ROLLER AND FUSING LAMP

⚠ CAUTION

- Do not touch the fusing lamp and rollers with your bare hands.

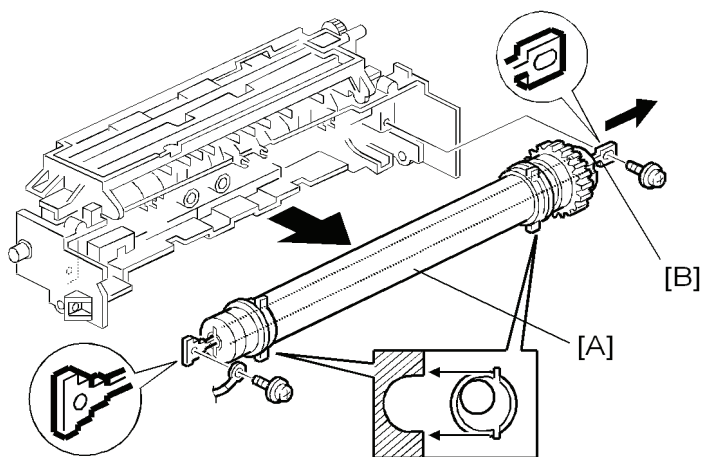

b130r911

- Hot roller stripper pawls and spacers (p.4-16)
- Hot roller assembly [A] (x 2)
- Fusing lamp [B]

↓ Note

- When reassembling, check that the direction of the fusing lamp is correct.

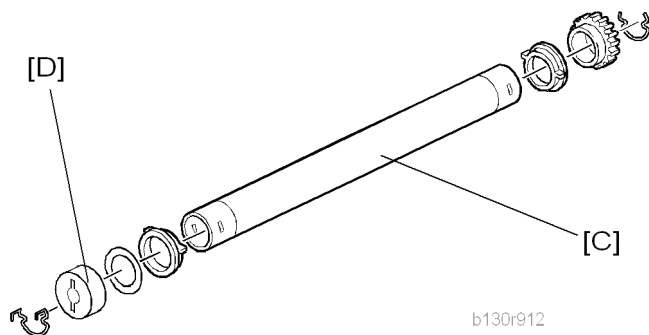

b130r912

- Hot roller [C] (2 C-rings, 1 spacer, 1 gear, 2 bushings, 1 cover [D])

Reassembling

Be sure that:

- The fusing lamp is positioned correctly.
- The fusing lamp does not touch the internal part of the hot roller.

4.5.5 THERMOSWITCHES AND THERMISTOR

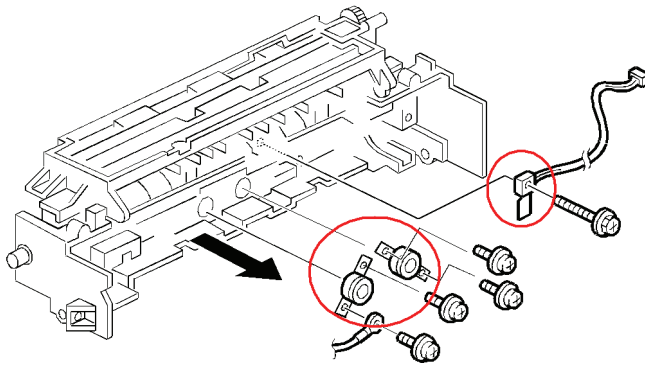

b130r913

1. Hot roller assembly (p.4-17 "Hot Roller and Fusing Lamp")
2. Thermoswitches (x 2 for each)
3. Thermistor (x 1)

Reassembling

Make sure of the following:

- That the thermistor is in contact with the hot roller.
- That the hot roller turns smoothly.

Note

- Do not recycle a thermoswitch that is already opened. Safety is not guaranteed if you do this.

4.5.6 PRESSURE ROLLER

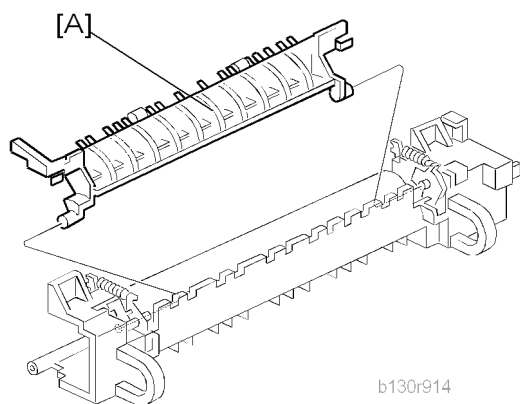

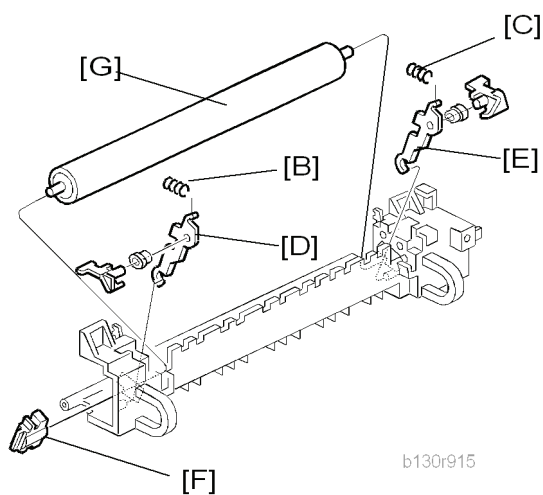

1. Separate the fusing unit into two sections (p.4-16).
2. Fusing entrance guide [A]



3. Two springs [B][C]
4. Two pressure arms [D][E]
5. Bushing [F]
6. Pressure roller [G]

4.5.7 CHECKING THE NIP BAND

You can check the nip band to see if the fusing unit is in a good condition—especially, if the hot roller and pressure roller are correctly installed.

1. Activate the SP mode.
2. Select SP1-109-001.
3. Specify "1."
4. Press the OK key.
5. Press the  key. The copy mode is activated.
6. Place an OHP sheet on the by-pass tray.
7. Press the  key. The copier feeds the OHP sheet, and stops it between the hot roller and the pressure roller for about 20 seconds.
8. Wait until the OHP sheet is output.
9. Press the  key.
10. Make sure SP1-109-001 is selected.
11. Specify "0".
12. Press the OK key.
13. Quit the SP mode.

You see an opaque stripe on the OHP sheet. This is the trace of the nip band. The normal nip band is symmetrical on the OHP sheet. Both ends are slightly thicker than the center.

 Note

- There are no specifications or standards for the nip band of this copier.

4.6 PCU AND QUENCHING LAMP

When handling the photo conductor unit (PCU), use caution:

- Do not touch the OPC drum with your bare hands. When the OPC drum is unclean, clean it with dry cloth, or clean it with wet cotton and wipe it with dry cloth.
- Do not use alcohol or any other chemicals to clean the OPC drum. These substances damage the OPC-drum surface.
- Keep PCUs in a cool, dry place.
- Do not expose the OPC to any corrosive gas such as ammonia.
- Do not shake a used PCU. Remaining toner and developer may spill out.
- Dispose of used PCUs in accordance with local regulations.

4.6.1 PCU

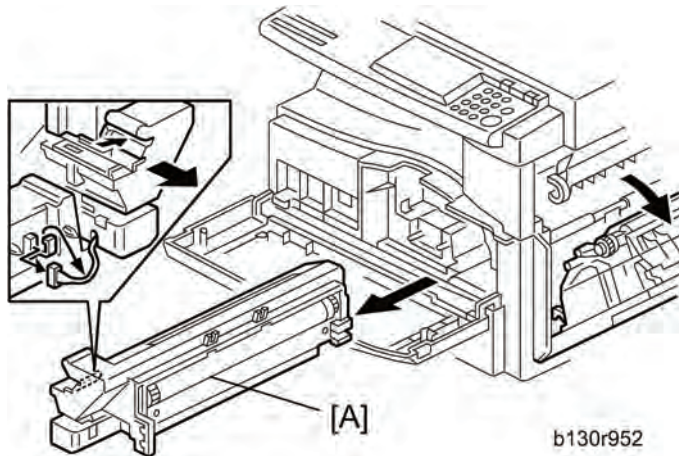

1. Open the right door.

↓ Note

- The PCU may become stuck if you try to remove it while the front door is closed.

2. Open the front door.
3. Remove the toner bottle holder.

↓ Note

- Clean all spilled toner off the toner bottle area and the inside of the front door.

4. Pull out the PCU [A] (☞ x 1).
5. When having installed a new PCU, remove the Styrofoam and tags (☞ p.2-5 "Copier" in the chapter "Installation").

Initialization

After you turn on the main power switch, the copier automatically initializes the new PCU. When the copier is executing initialization, it is important that you:

- Do not turn off the main power switch.
- Do not open or remove exterior covers.

4.6.2 QUENCHING LAMP

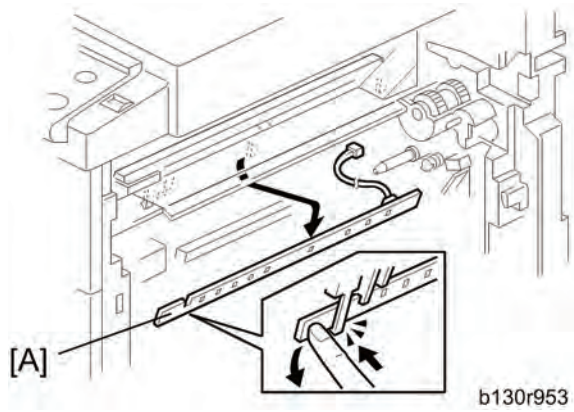



1. PCU (☞ p.4-22)
2. Quenching lamp [A] (☞ x 1)

4.7 EXHAUST FAN AND MAIN MOTOR

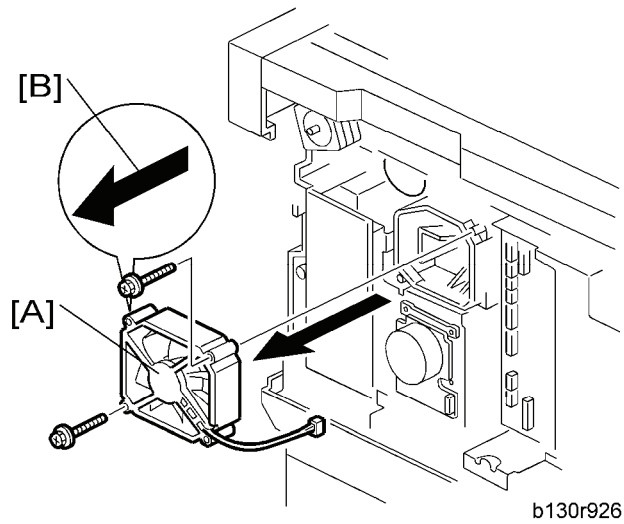
4.7.1 EXHAUST FAN



1. Rear cover ( p.4-3)
2. Exhaust fan [A] ( x 2,  x 1)

Reassembling

Make sure that the arrow [B] on the frame points to the rear side. The arrow indicates the direction of airflow.

4.7.2 MAIN MOTOR

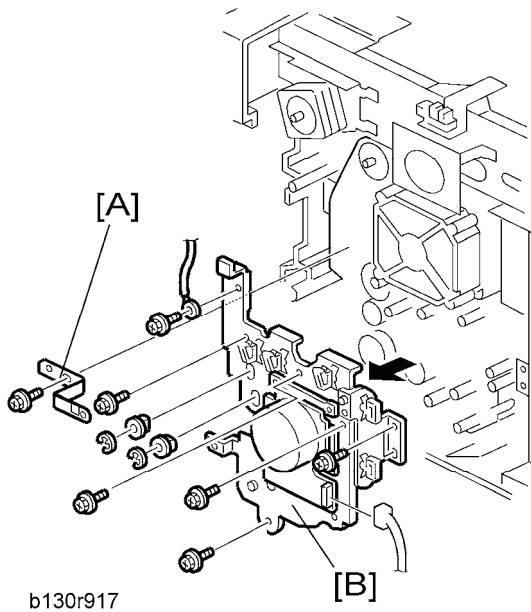

1. Rear cover (p.4-3)
2. High-voltage power supply board (p.4-43)
3. Ground plate [A] (x 1)
4. Main motor with the gear cover [B] (x 1, x 7, x 2, 2 bushings)

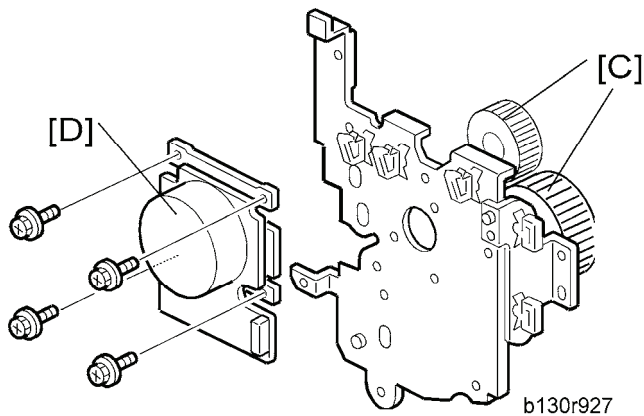

5. All gears [C]
6. Main motor [D] (x 4)

Reassembling

Attach the main motor before attaching the gears.

4.8 PAPER FEED

4.8.1 PAPER FEED ROLLER AND FRICTION PAD

When handling the paper tray or the paper feed roller, use caution:

- Do not touch the surface of paper feed rollers.
- To avoid paper jams, correctly set the side and end fences in the paper tray.

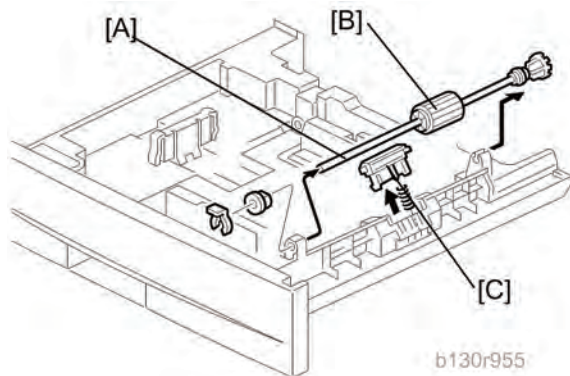

1. Paper tray
2. Shaft [A] (🔩 x 1)
3. Remove either or both of the following:
 - Paper feed roller [B]
 - Friction pad [C]

4.8.2 PAPER END SENSOR

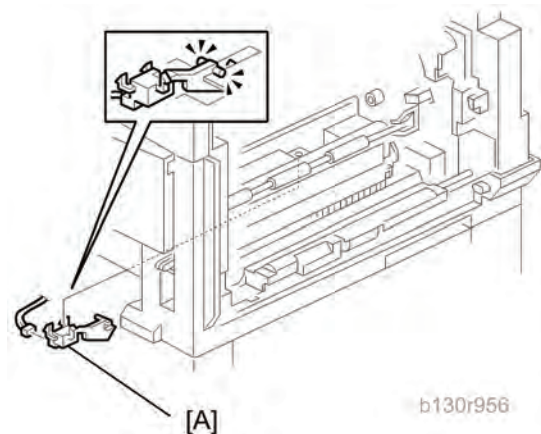

1. Paper tray
2. Open the right door.
3. PCU (🔧 p.4-22)
4. Paper end sensor [A] (🔩 x 1)

4.8.3 REGISTRATION SENSOR

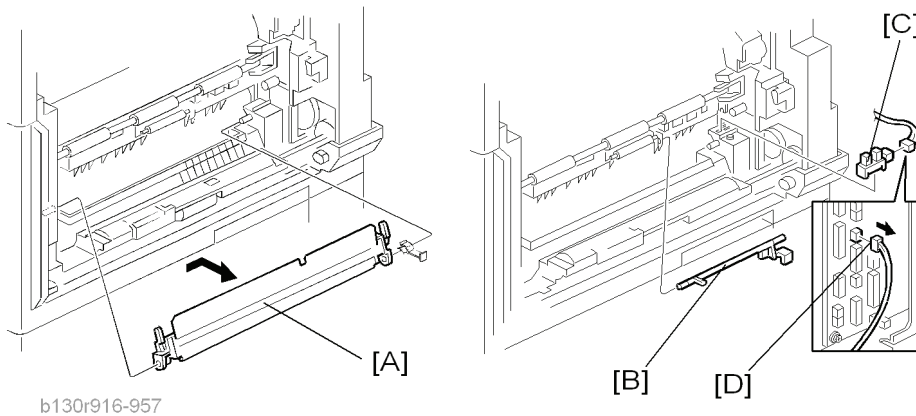

1. Paper tray
2. Open the right door.
3. Open the paper guide [A].

↓ Note

- Remove the paper guide (Clip x 1) if you have difficulty removing the registration sensor.

4. Registration sensor feeler [B]
5. Registration sensor [C] (E) x 1)

↓ Note

- Disconnect the connector (CN127 [D]) if you have difficulty removing the registration sensor.

4.8.4 BYPASS PAPER END SENSOR

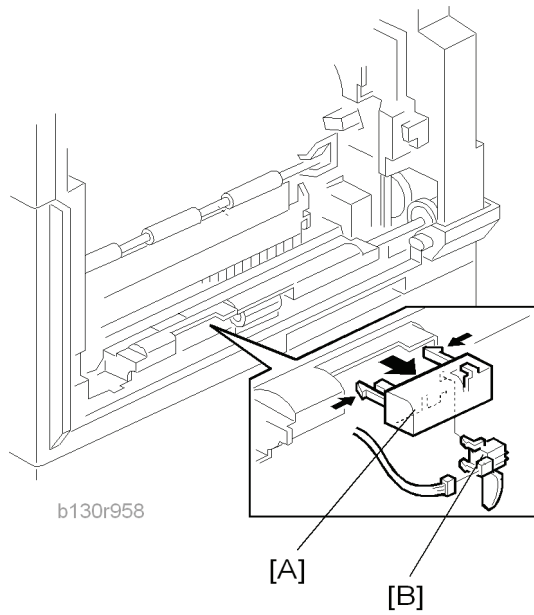

1. Right door (🔧 p.4-6)
2. Sensor compartment [A]
3. Bypass paper end sensor [B] (🔧 x 1)

4.8.5 BYPASS FEED ROLLER

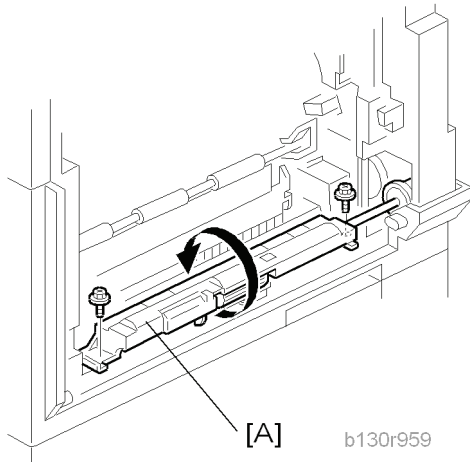

1. Right door (p.4-6)
2. Turn the feed roller housing upside down [A] (x 2).

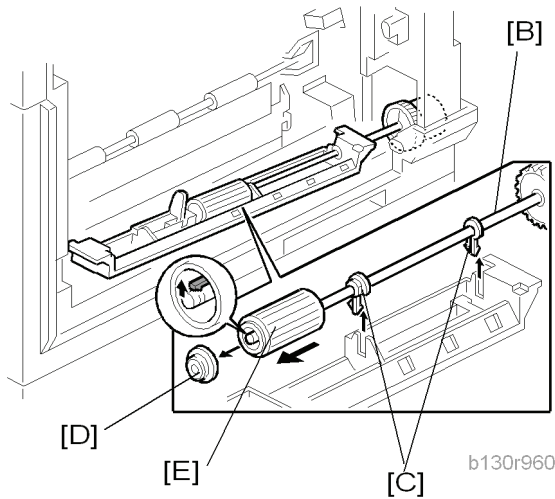

3. Feed roller shaft [B] (2 snap pawls [C], 1 spacer [D])
4. Bypass feed roller [E]

Replacement
and
Adjustment

4.8.6 BYPASS FEED CLUTCH AND FRICTION PAD

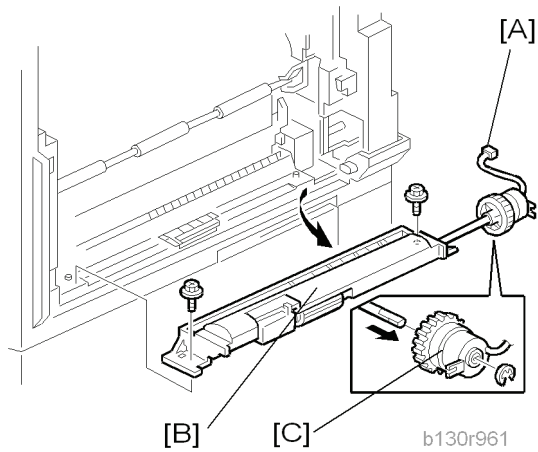

1. Rear cover (🔧 p.4-3)
2. Right door (🔧 p.4-6)
3. Disconnect the bypass feed clutch connector [A] (CN93).
4. Bypass feed roller housing [B] (🔧 x 2)
5. Bypass feed clutch [C] (Ⓒ x 1)

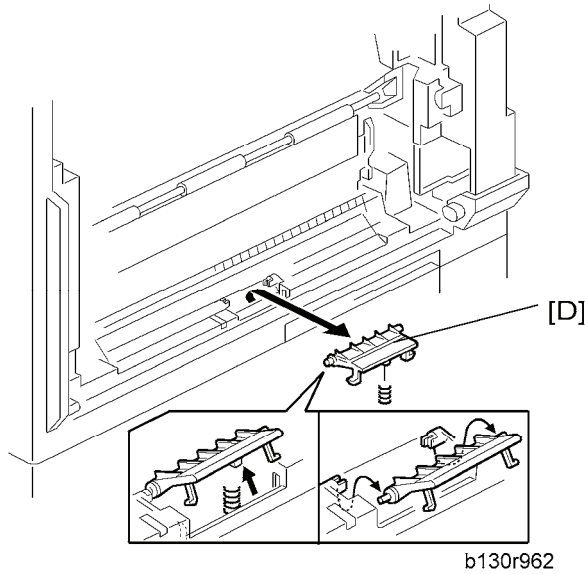

6. Bypass friction pad [D]

4.8.7 PAPER FEED AND REGISTRATION CLUTCHES

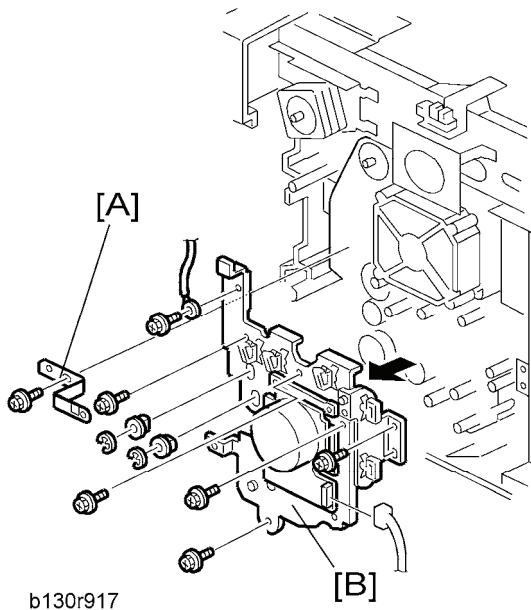

1. Paper tray
2. High-voltage power supply board (p.4-43)
3. Ground plate [A] (x 1)
4. Gear cover [B] (x 1, x 7, x 2, 2 bushings)

Note

- Do not remove the main motor from the gear cover.

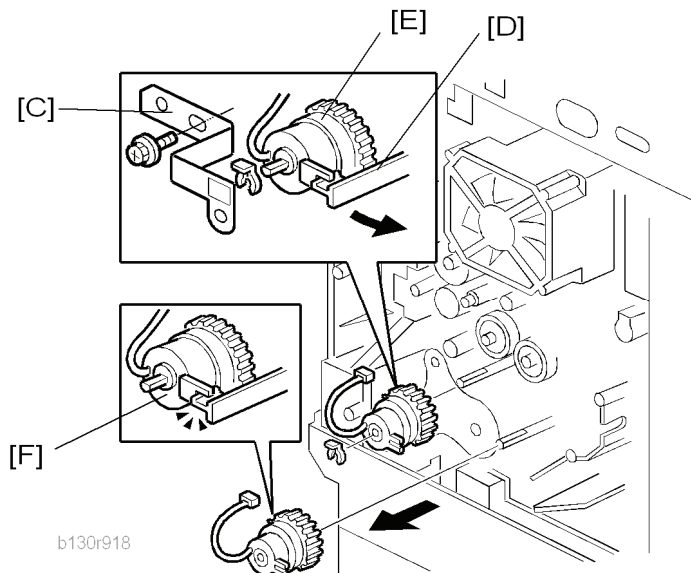

5. Ground plate [C] (x 1)
6. Slowly push the clutch holder [D] and remove the registration clutch [E] (x 1, x 1).
7. Paper feed clutch [F]

4.9 IMAGE TRANSFER

4.9.1 TRANSFER ROLLER

CAUTION

- Do not touch the transfer roller with your bare hands.
- Do not scratch the transfer roller. The transfer roller is easily damaged.

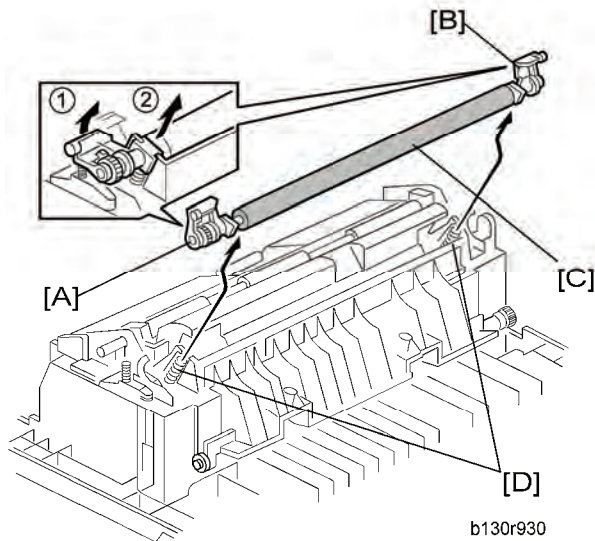

1. Right door (see p.4-6)
2. Raise the levers [A],[B] at the ends of the image transfer roller.
3. Release the image transfer roller [C].

Reassembling

Make sure that the springs [D] are in the original positions.

4.9.2 ID SENSOR AND DUPLEX ROLLER

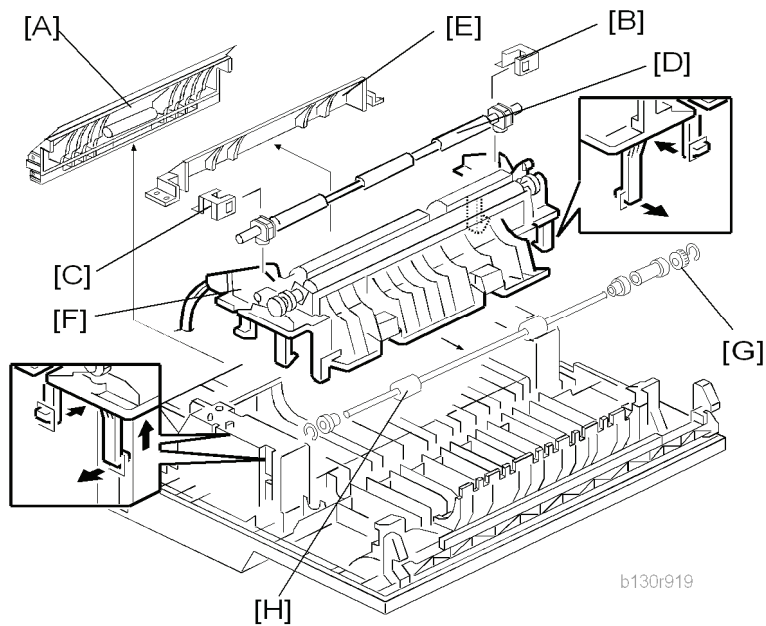

1. Right door (p.4-6)
2. Lower guide [A]
3. Idle roller holders [B][C]
4. Idle roller [D]
5. Roller guide [E]
6. Transfer unit [F]
7. One-way gear [G] (⊗ x 1)
8. Duplex roller [H] (⊗ x 1, 3 bushings)

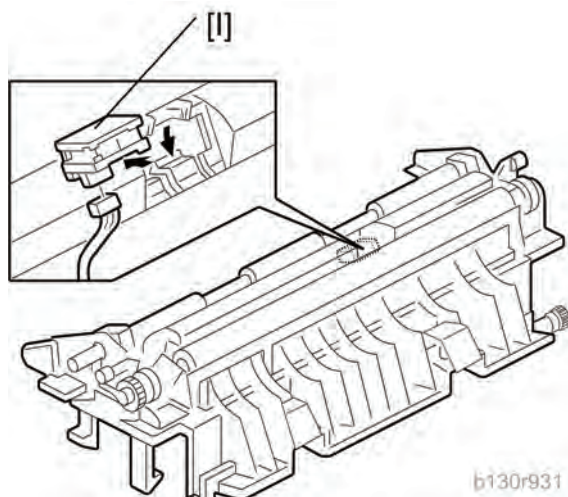

9. ID sensor [I] (⊗ x 1)

4.9.3 DISCHARGE PLATE

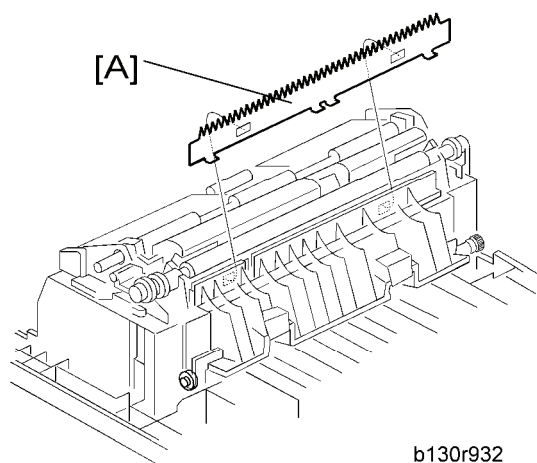

b130r932

1. Right door (p.4-6)
2. Discharge plate [A]

4.10 BICU AND CONTROLLER BOARD

⚠ CAUTION

- Turn off the main power switch and unplug the machine before starting replacement.
- Before turning off the main power switch, check that no mechanical component is operating. Mechanical components may stop out of their home positions if you turn off the main power switch while they are operating. The component may be damaged if you try to remove it when it is not in the home position.

4.10.1 BICU

Preparation

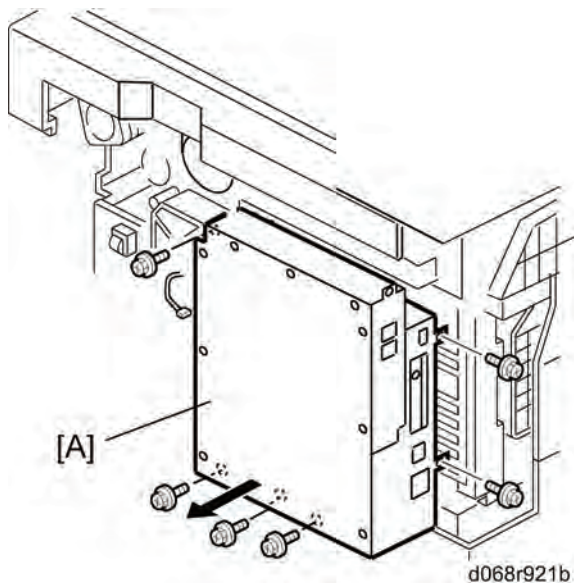

- Before replacing the NVRAM, be sure to save the NVRAM data.
- Saving from the BICU NVRAM to an SD card (➡ p.5-4 "NVRAM Data Upload/Download" in the "System Service Mode" of the appendices of the this manual.)

Procedure

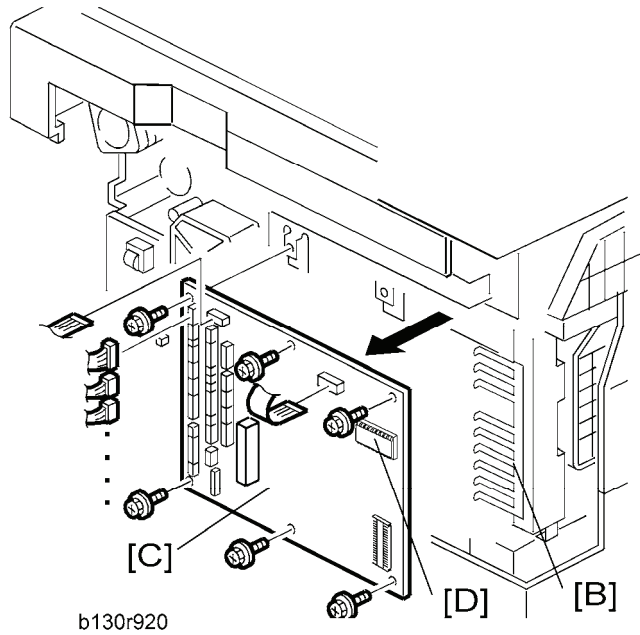

1. Rear cover (➡ p.4-3)
2. Scanner upper left cover (➡ p.4-5)
3. Controller box [A] (⚙ x 6, 📁 x 1)



4. Ground plate [B] ( x 2)
5. BICU [C] (all , 2 flat cables,  x 6)

 Note



- When replacing the BICU, remove the NVRAM [D] from the board. Install the NVRAM to the new board.
6. After replacing the NVRAM, copy the saved data to the NVRAM.
 - From an SD card to the NVRAM ( p.5-4 "NVRAM Data Upload/Download" in the "System Service Mode" of the appendices of this manual.)

4.10.2 CONTROLLER BOARD

Preparation:



- Before replacing the controller board, be sure to print out SMC or save the NVRAM data.
- Saving from the Controller NVRAM to an SD card ( p.5-4 "NVRAM Data Upload/Download" in the "System Service Mode" of the appendices of this manual.)

Procedure

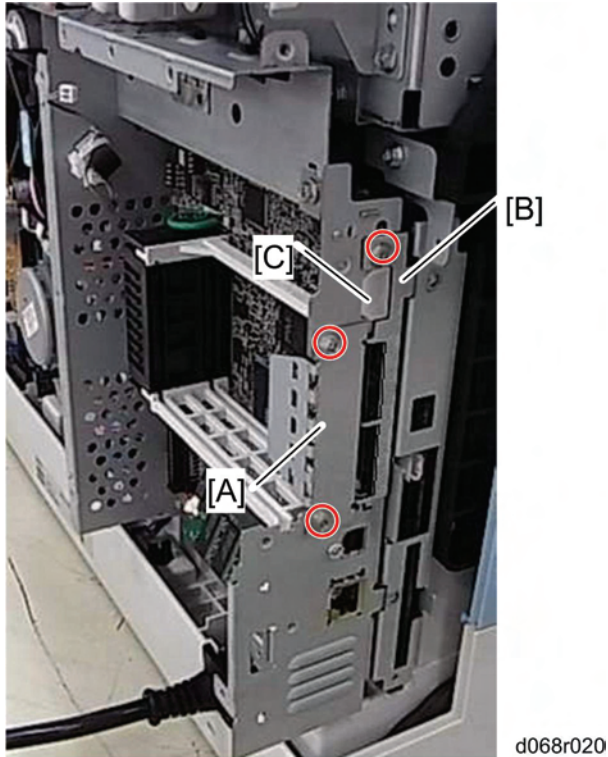
1. Rear cover ( p.4-3)
2. Scanner upper left cover ( p.4-5)
3. FCU ( p.4-47)



d068r020

4. Remove the printer/scanner SD card.
5. Remove I/F cover [A] (or I/F options if they have been installed) ( x 2).
6. Remove the bracket [B] ( x 1).
7. Remove the USB cap [C].

Replacement and Adjustment

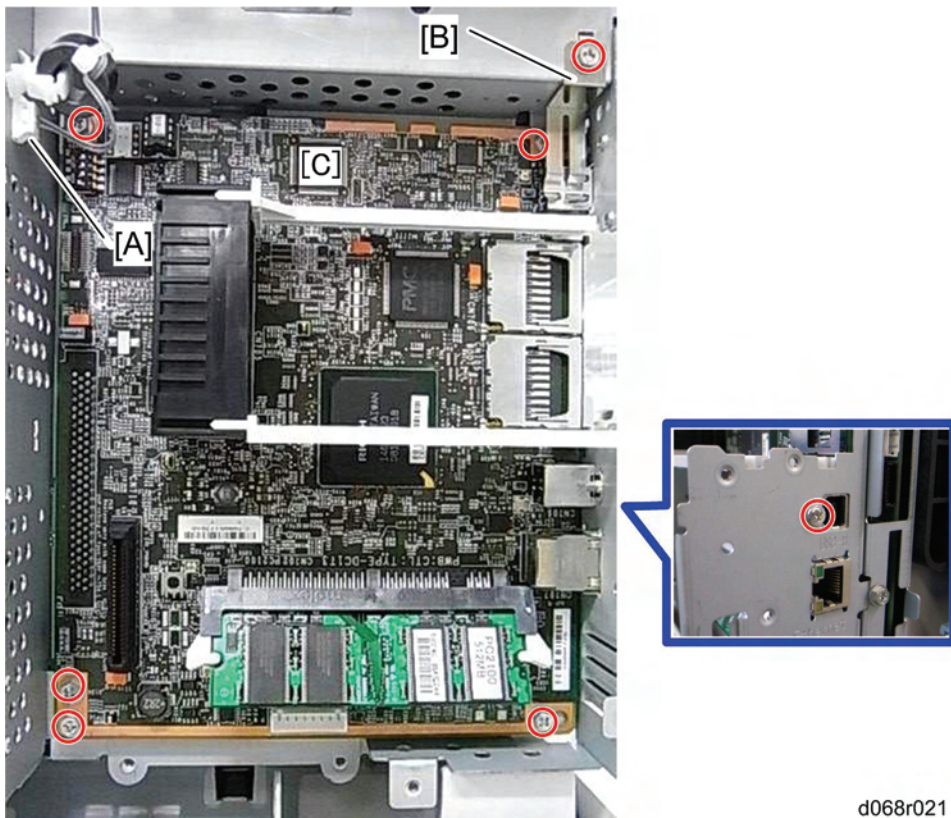

d068r021

8. Remove the relay connector [A].

BICU and Controller Board

9. Remove the ground plate [B] (⚙️ x 1).
10. Remove the controller board with the rails [C] (⚙️ x 6).

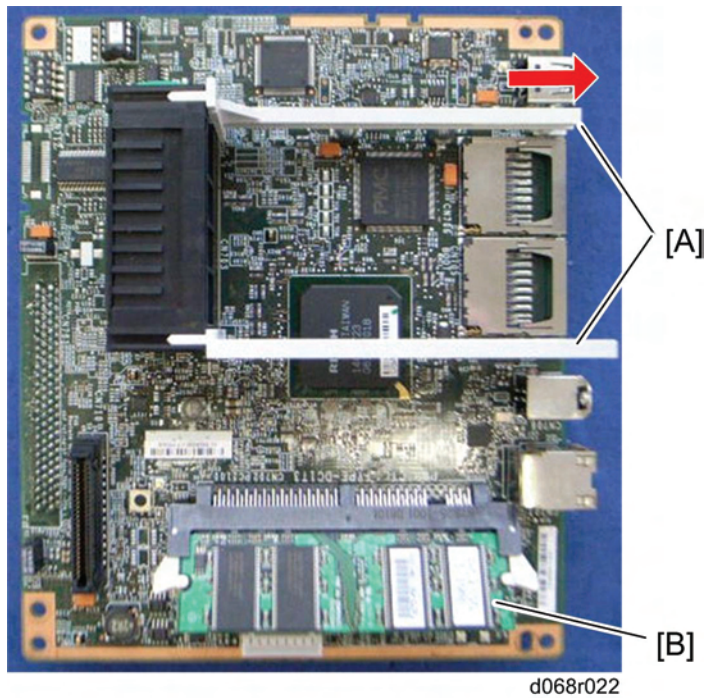

11. Release the hooks, and then pull out the rails [A].
12. Remove the DIMM [B] if it has been installed.

⚠️ Note

- When replacing the controller board, remove the NVRAMs from the board. Install the NVRAMs to the new board.

When installing a new controller board

1. Install the NVRAM from the old controller board on a new controller board.
1. Install the new controller board in the machine.
2. Disconnect the cables of the HDD from the controller board if the HDD option has already been installed.

 **Important**

- Disconnecting the cables of the HDD is very important. Otherwise, the HDD is automatically formatted and all data in the HDD is lost due to the security limitation.
3. Reassemble the machine.
 4. Turn on the main power of the machine.
 - If the HDD option has not been installed, the installation procedure is completed.
 - If the HDD option has already been installed, go to next step.
 5. Turn off the main power of the machine, and then connect the cables of the HDD again.

 **Note**

- Make sure you print out the SMC reports ("SP Mode Data" and "Logging Data") before you replace the NVRAM.

 **CAUTION**

- Keep NVRAMs away from any objects that can cause static electricity. Static electricity can damage NVRAM data.
- Make sure the NVRAM is correctly installed on the controller board.

When replacing the NVRAM on the controller board

1. Disconnect the cables of the HDD from the controller board.

★ Important

- Disconnecting the cables of the HDD is very important. Otherwise, the HDD is automatically formatted and all data in the HDD is lost due to the security limitation.

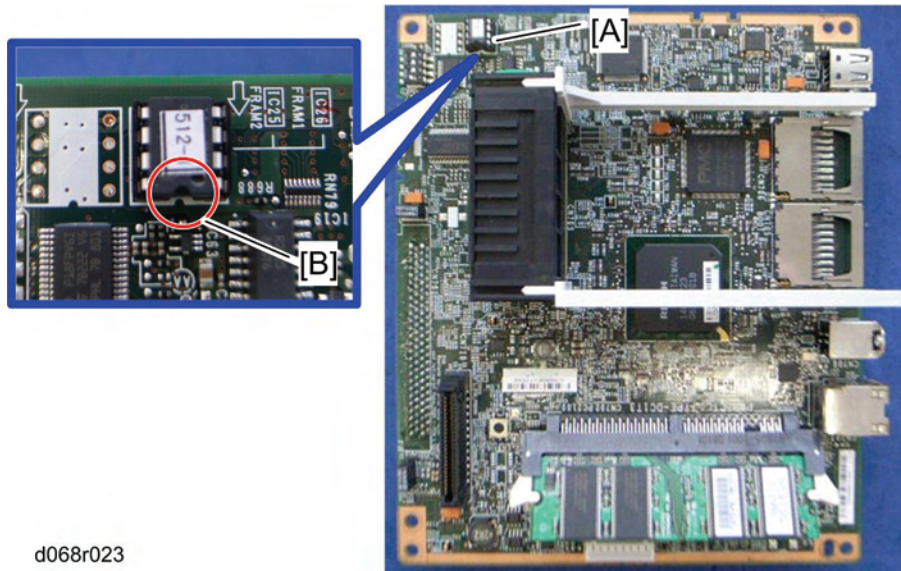

d068r023

2. Install a New NVRAM on the controller. Then reassemble the machine.
 - When you replace the NVRAM [A], make sure that the NVRAM is correctly installed.
 - The mark [B] on the NVRAM should be directed to the down side (seem from the back side of the machine).
3. Remove the Security Card or Printer/Scanner card from SD slot 1.
4. Install a new Security Card in SD slot 1.
5. Turn the main switch on.
6. SC995-02 occurs.
7. Turn the machine off.
8. Connect the cables of the HDD to the controller board.
9. Reassemble the machine, and then turn on the machine.
10. Do the process control self-check.
11. Do ACC for the copier application program.
12. Do ACC for the printer application program.

13. Do SP5-878-001 to install the DataOverwriteSecurity application.
14. Do SP5878-002 to install the HDD Encryption application.
15. Merge all applications in a one SD card in SD slot 1 with SP5831-001 if necessary.
16. Copy the old NVRAM data to the new NVRAM with SP5-825 or input the SMC data in the machine. (For details, refer to the p.5-4 "NVRAM Data Upload/Download" in the "System Service Mode" of the appendices of the this manual)

4.11 OTHER REPLACEMENTS

4.11.1 DUPLEX MOTOR

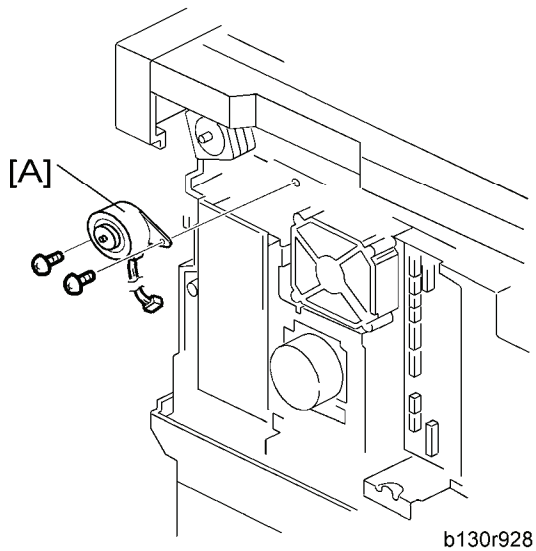

1. Rear cover (🔧 p.4-3)
2. Duplex motor [A] (🔧 x 1, 🛠️ x 2)

4.11.2 HIGH-VOLTAGE POWER SUPPLY BOARD

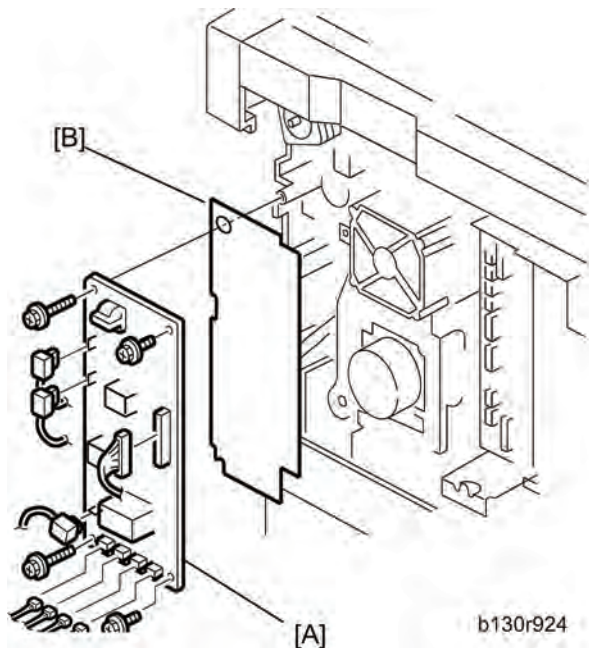

1. Rear cover (🔧 p.4-3)
2. High-voltage power supply board [A] (all 📄, 🔧 x 4)

↓ Note

- Remove the insulating sheet [B] if you are going to remove the contact-release solenoid (🔧 p.4-45) or the gear cover (🔧 p.4-31 "Paper Feed and Registration Clutches").

4.11.3 PSU

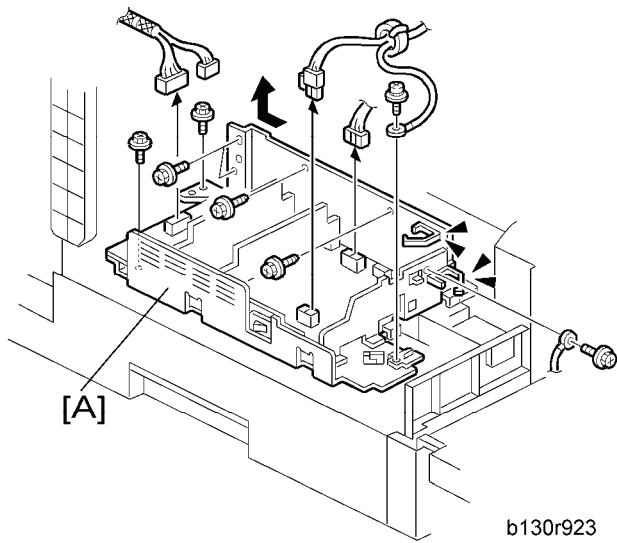

1. Open the front door.
2. Copy tray (p.4-4)
3. PSU assembly [A] (x 4, x 8)

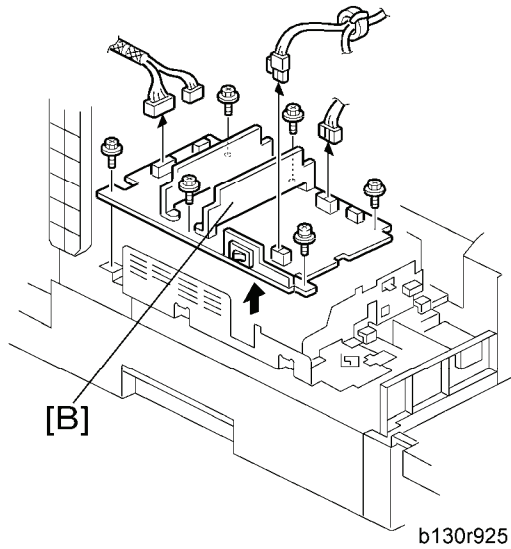

4. PSU [B] (x 4, x 6)

4.11.4 CONTACT-RELEASE SOLENOID

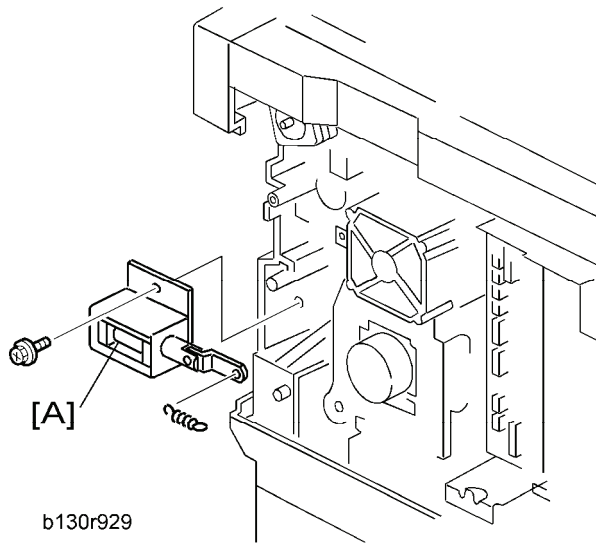

1. Rear cover (🔧 p.4-3)
2. High-voltage power supply board (🔧 p.4-43)
3. Contact-release solenoid [A] (1 spring, 🔧 x 1)

Replacement
and
Adjustment

4.11.5 TONER SUPPLY CLUTCH

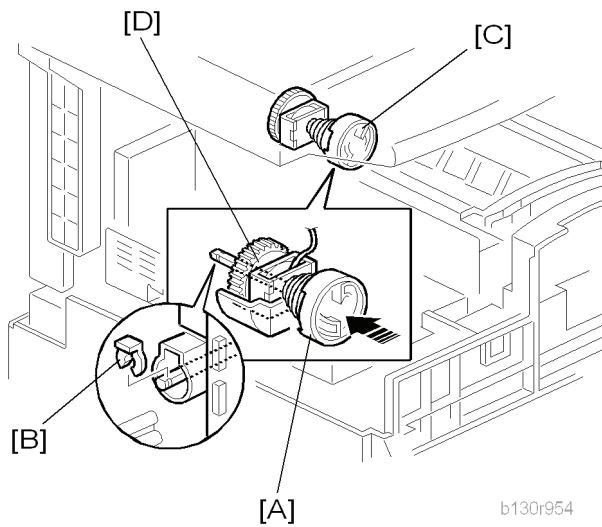

1. Toner bottle holder
2. Copy tray (p.4-4)
3. Rear cover (p.4-3)
4. Disconnect the connector on C19 on the BICU.
5. Push the clutch coupler [A] to the rear side, and remove the clip ring [B] from the back of the copier.
6. Coupler and spring [C]
7. Lift the toner supply clutch [D] and remove it.

Note

- When removing, note how the wire goes through a clamp, and also note where it passes through the rear of the machine.

4.11.6 FCU

Lithium Batteries

⚠ CAUTION

- Incorrect replacement of lithium battery(s) on the controller or on the fax unit poses risk of explosion. Replace only with the same type or with an equivalent type recommended by the manufacturer. Discard used batteries in accordance with the manufacturer's instructions.

Procedure

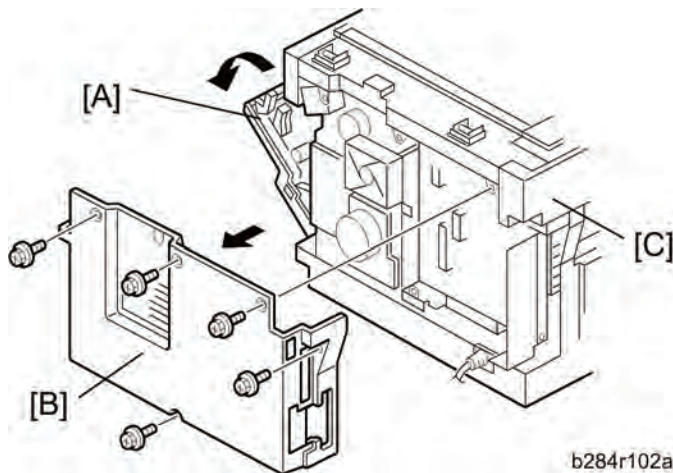

1. Open the right door [A].
2. Rear cover [B] ( x 5).
3. Scanner upper left cover [C]

Other Replacements

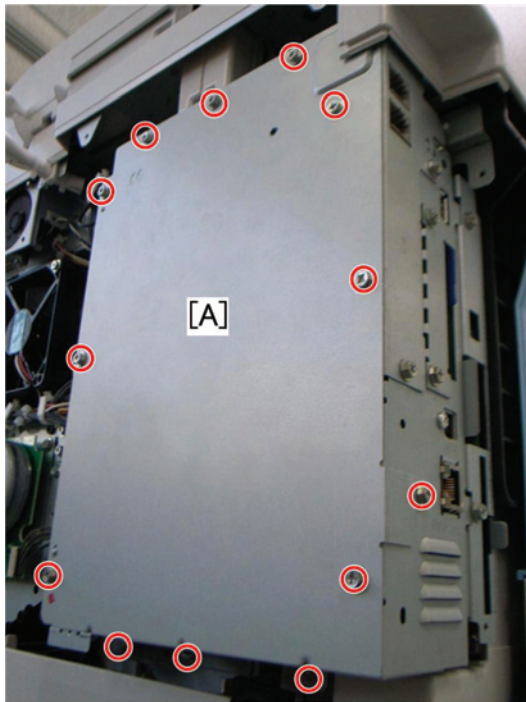

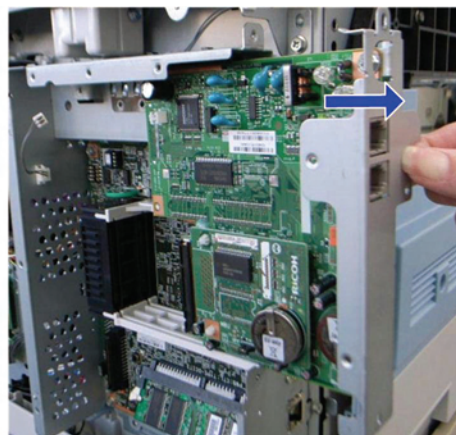
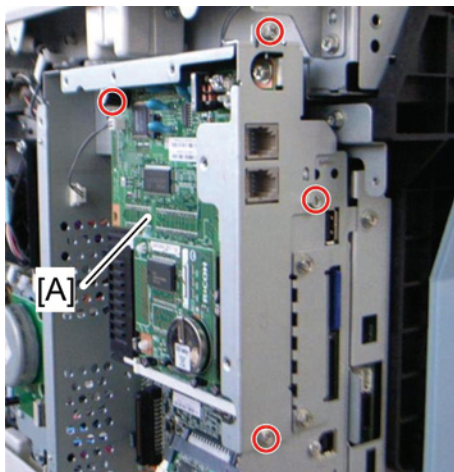

d068r025

4. Controller box cover [A] ( x 13)



d068r026

5. FCU [A] ( x 4,  x 1)
6. When you replace the FCU board, remove the MBU board from the old FCU board and install it on the new FCU board.
7. Set the correct date and time with the User Tools: User Tools> System Settings> Timer Setting> Set Date/Time

 Note

- Do not turn off the battery switch (SW1).
- Do SP6-101 in the "Fax SP" to print the system parameters, and check the settings.

4.12 LASER UNIT

WARNING

- Turn off the main power switch and unplug the copier before starting replacement. The laser beam can damage your eyes severely.

CAUTION

- Do not touch the screws on the LD board on the LD unit. Do not try to adjust any part of the LD unit. The LD unit is precision adjusted before shipment.
- Do not touch the polygon mirror, shield glass, or lenses with your bare hands.

4.12.1 LOCATION OF THE CAUTION DECAL

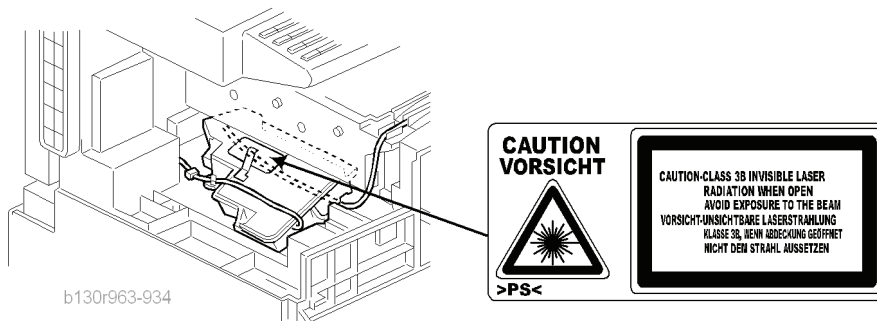

4.12.2 LASER UNIT

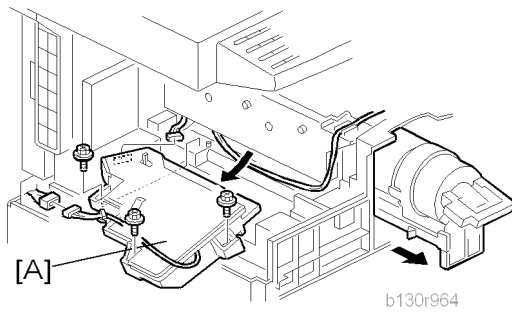

1. PSU assembly (🔧 p.4-44)
2. Toner bottle holder
3. Laser unit [A] (🔧 x 3, 📄 x 2)

Reassembling

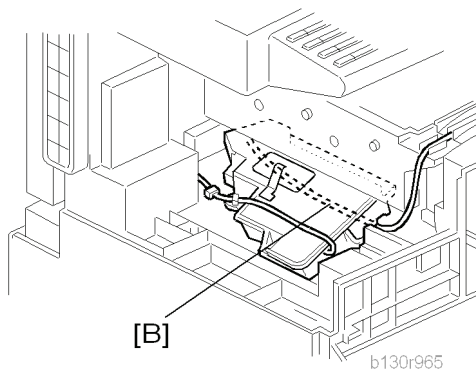

Make sure that the cable [B] passes under the unit.

4.12.3 LD UNIT AND POLYGON MIRROR MOTOR

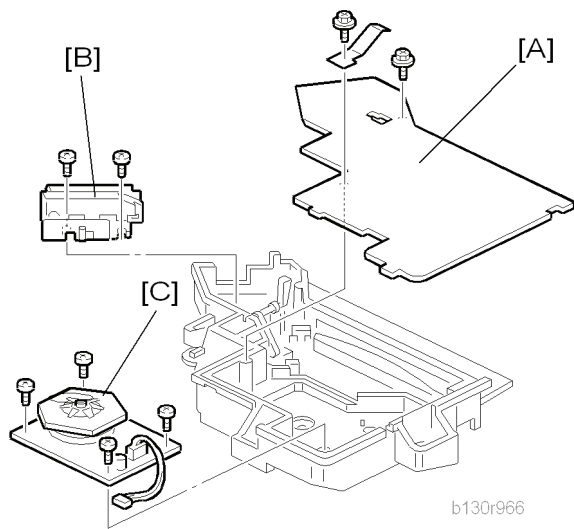

1. Laser unit (☞ p.4-50)
2. Laser unit cover [A] (☞ x 2, 1 grounding plate)
3. LD unit [B] (☞ x 2)
4. Polygon mirror motor [C] (☞ x 4)

Reassembling

Check that the polygon mirror and toroidal lens are clean. Dust or other foreign substances may interfere with the operation of the LD unit.

4.13 ARDF

4.13.1 ARDF

1. Rear cover (🔧 p.4-3)

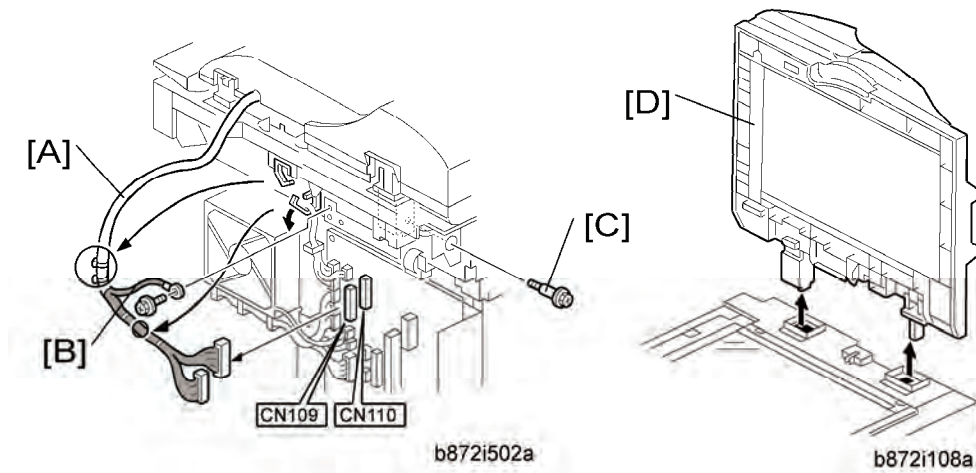

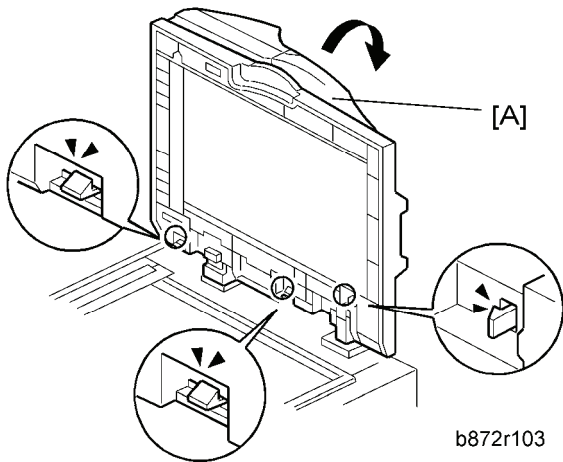

2. Remove the DF interface cables [A] (🔌 x 2, hook x 2).
3. Remove the ground cable [B] (🔧 x 1).
4. Remove the stud screw [C].
5. Remove the ARDF [D].

4.13.2 DF REAR COVER

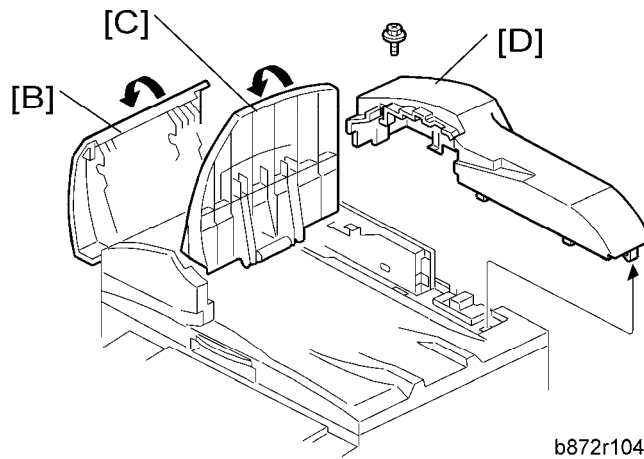

1. Open the ARDF [A].
2. Release the three hooks



3. Open the DF left cover [B].
4. Open the original tray [C].
5. DF rear cover [D] ( x 1, hook x 4)

4.13.3 ORIGINAL FEED UNIT

1. Open the DF left cover.

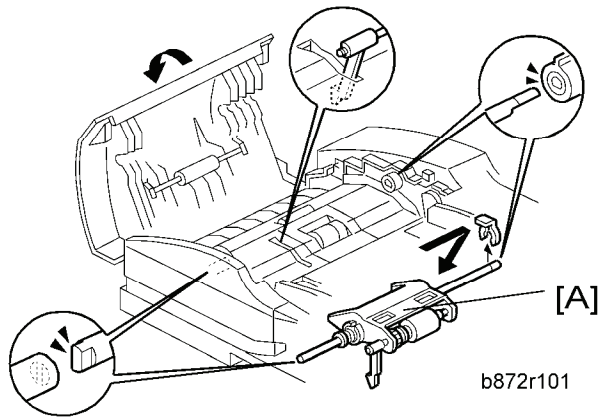

2. Original feed unit [A] (☞ x 1)

4.13.4 SEPARATION ROLLER

1. Open the DF left cover.
2. Original feed unit (☞ p.4-54)

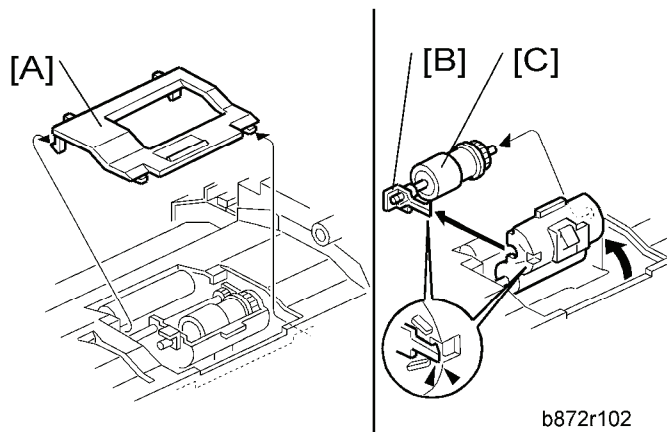

3. Separation roller cover [A] (hook x 2)
4. Separation roller stopper [B] (hook)
5. Separation roller [C]

4.13.5 DF DRIVE BOARD

1. DF rear cover (🔧 p.4-53)

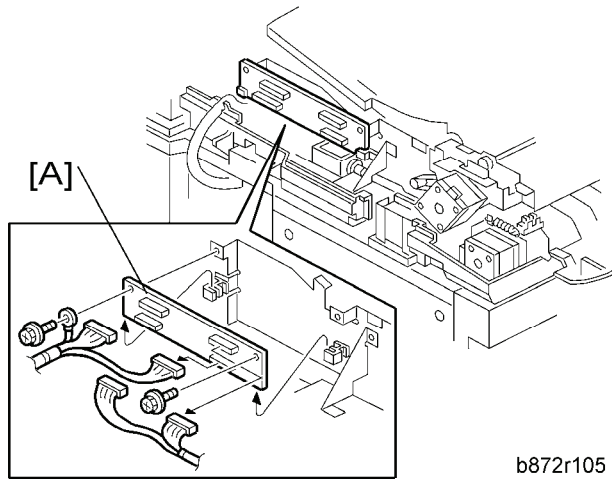

2. DF drive board [A] (🔧 x 2, 📦 x 4, ground cable x 1)

4.13.6 ORIGINAL SET AND DF INVERTER SENSOR

1. Open the DF left cover.
2. Original feed unit (🔧 p.4-54)
3. DF feed clutch (🔧 p.4-59)

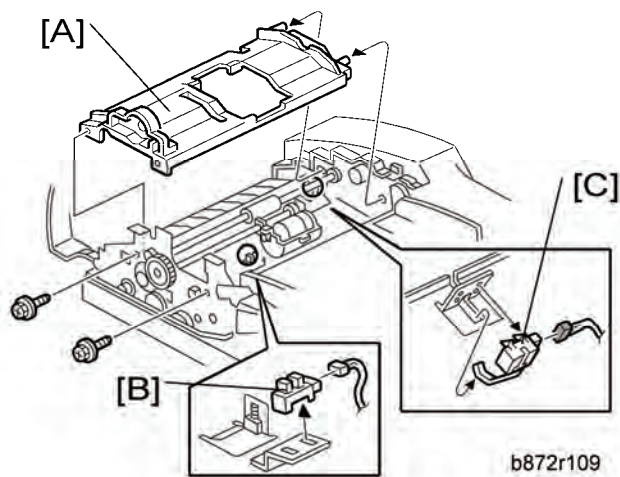

4. Original feed-in guide plate [A] (🔧 x 2).
5. Original set sensor [B] (📦 x 1, hook)
6. DF inverter sensor [C] (📦 x 1, hook)

4.13.7 DF REGISTRATION AND DF EXIT SENSOR

1. Open the DF left cover.
2. Original feed unit (🔧 p.4-54)
3. DF feed clutch (🔧 p.4-59)
4. Original feed-in guide plate (🔧 p.4-55 "Original Set and DF Inverter Sensor")
5. DF feed motor (🔧 p.4-58)
6. DF transport motor (🔧 p.4-58)

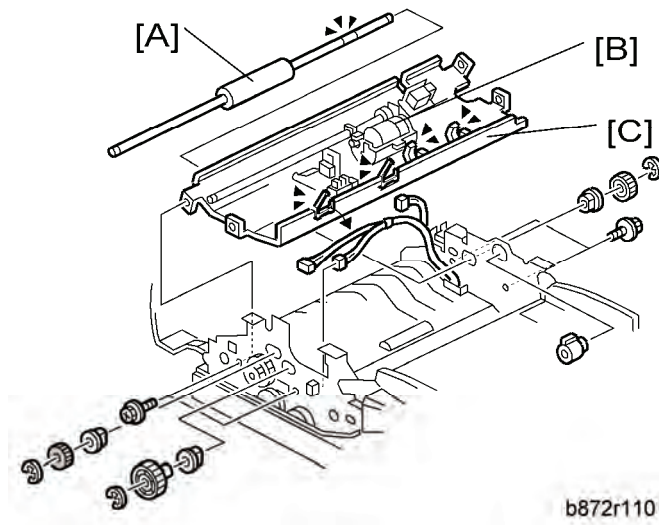

7. DF transport roller [A] (🔧 x 2, gear x 2, bushing x 2)
8. DF separation roller unit [B] (🔧 x 2, gear x 1, bushing x 2)
9. Inverter upper guide plate [C] (🔧 x 4, 📏 x 3, 📏 x 4)

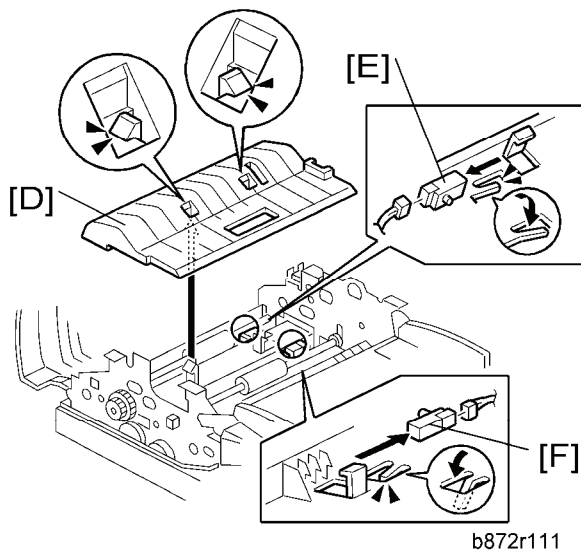

10. Inverter lower guide plate [D] (hook x 2)
11. DF registration sensor [E] (☞ x 1, hook)
12. DF exit sensor [F] (☞ x 1, hook)

DF Registration Sensor Reflector

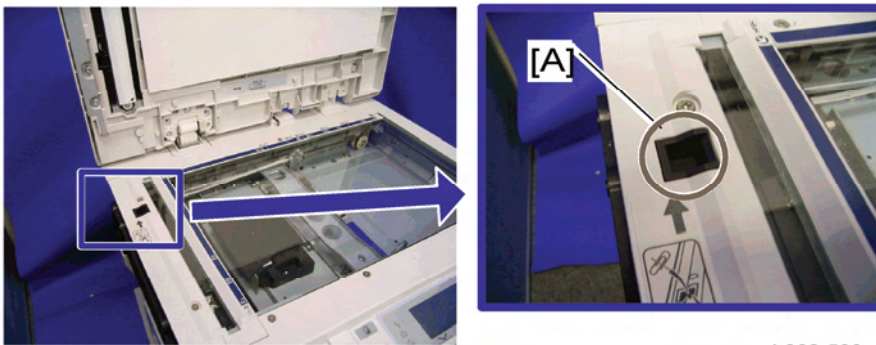

Clean the SD registration sensor reflector [A] as necessary.

4.13.8 DF FEED MOTOR

1. DF rear cover (🔩 p.4-53)

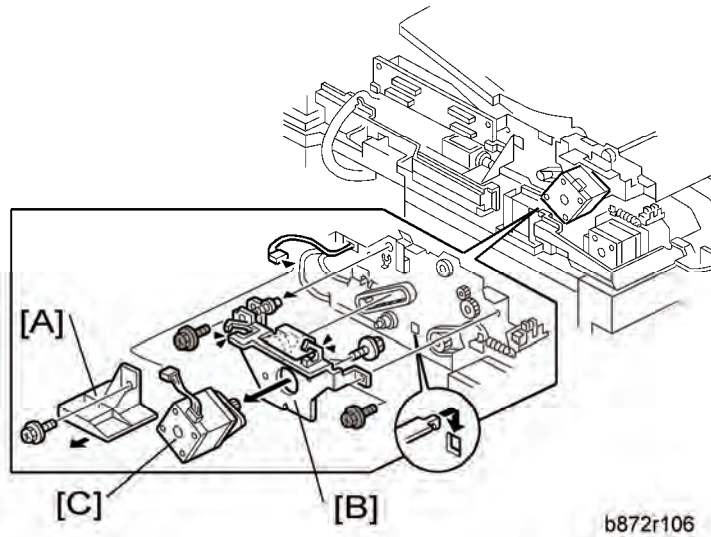

2. Inner cover [A] (🔩 x 1)
3. DF feed motor with bracket [B] (🔩 x 2, 🌀 x 4, 📦 x 3, timing belt)
4. DF feed motor [C] (🔩 x 2)

4.13.9 DF TRANSPORT MOTOR

1. DF rear cover (🔩 p.4-53)
2. DF feed motor (🔩 p.4-58)

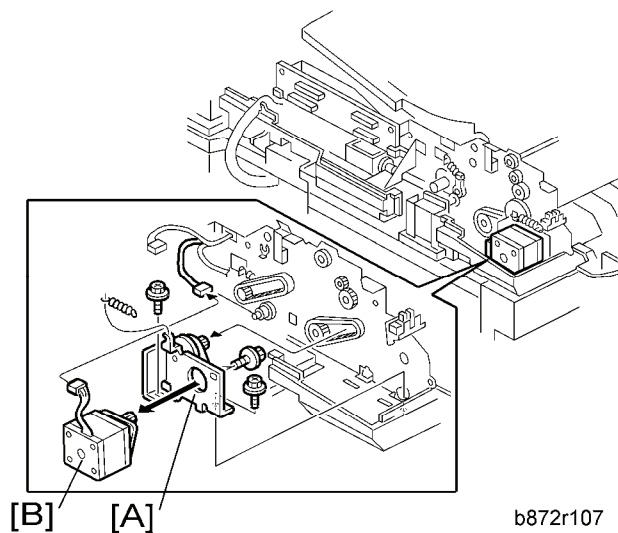

3. DF transport motor with bracket [A] (🔩 x 2, spring x 1, timing belt)
4. DF transport motor [B] (🔩 x 2)

4.13.10DF FEED CLUTCH

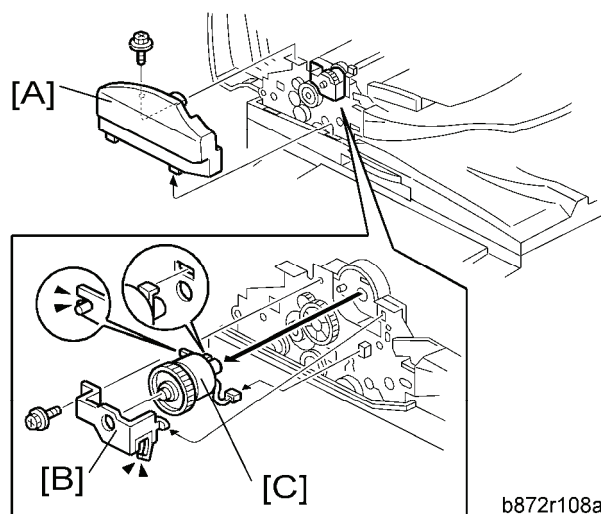

1. Open the DF left cover.
2. DF front cover [A] (🔩 x 1)
3. Bracket [B] (🔩 x 1, 📐 x 1)
4. DF feed clutch [C] (📐 x 1)

4.14 ADJUSTING COPY IMAGE AREA

Adjust the copy image area under any of the following conditions:

1. After clearing engine data (SP5-801-002 or SP5-998-001).
2. After replacing any of the following components:
 - First scanner or second scanner
 - Lens block
 - Scanner motor
 - Polygon mirror motor
 - Paper tray

4.14.1 PRINTING

Make sure that the paper is correctly loaded in each paper tray before starting the adjustment procedures in this section.

Adjusting Registration

Use the Trimming Area Pattern (SP5-902-001 > 10) for this adjustment.

1. Print out the test pattern with the paper fed from the regular paper tray.
2. Print out the test pattern with the paper fed from the by-pass tray.
3. Print out the test pattern by selecting duplex printing.

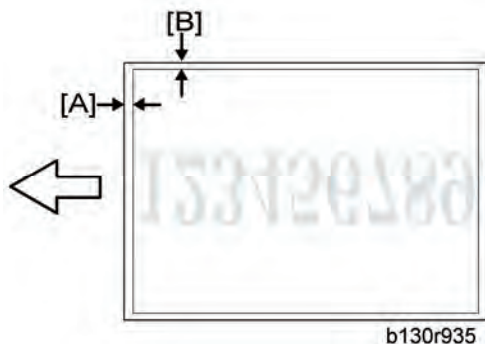

4. Measure the distance between the leading edge of the image area and the leading edge of the paper [A].

↓ Note

- The diagram shows the paper on the copy tray. Note that the paper is output with the face down.

SP	Specification
SP1-001-001 (All Trays)	0 ± 2 mm
SP1-001-002 (By-pass)	0 ± 2 mm
SP1-001-003 (Duplex)	0 ± 4 mm

5. Adjust the leading edge registration (SP1-001).
6. Measure the distance between the side edge of the image area and the side edge of the paper [B].

SP	Specification
SP1-002-001 (1st tray)	0 ± 2 mm
SP1-002-002 (2nd tray)	0 ± 2 mm
SP1-002-005 (By-pass)	0 ± 4 mm
SP1-002-006 (Duplex)	0 ± 4 mm

7. Adjust the side-to-side registration (SP1-002).
8. Specify "0" (zero) in SP5-902-001 after finishing the adjustment procedure.

Adjusting Blank Margin

Use the Trimming Area Pattern (SP5-902-001 > 10) for this adjustment.

1. Print out the test pattern.

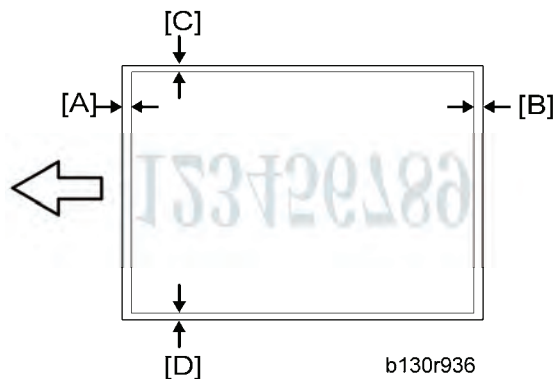

2. Measure the distance between the four edges of the image area and the four edges of the paper [A][B][C][D].

Note

- The diagram shows the paper on the copy tray. Note that the paper is output with the face down.

3. Adjust the blank margin (SP2-101).

SP	Specification
SP2-101-001 (Leading Edge) [A]	2 ± 1.5 mm
SP2-101-002 (Trailing Edge) [B]	$2 +2.5/-1.5$ mm
SP2-101-003 (Left Side) [C]	2 ± 1.5 mm
SP2-101-004 (Right Side) [D]	$2 +2.5/-1.5$ mm

Note

- The "Left Side" and "Right Side" comes to your left-hand side and right-hand side respectively when you view the copied image with the leading edge upwards.

4. Specify "0" (zero) in SP5-902-001 after finishing the adjustment procedure.

Adjusting Main-Scan Magnification

Use the Grid Pattern (Single Dot) (SP5-902-001 > 5) for this adjustment.

SP	Specification
SP2-998-001 (Main Mag-print)	100 ± 1%

1. Print out the test pattern.
2. Measure the sides of squares. Each side should be 2.7-mm long.)
3. Adjust the main-scan magnification (SP2-998-001: Main Mag-print).
4. Specify "0" (zero) in SP5-902-001 after finishing the adjustment procedure.

4.14.2 SCANNING

Preparation:

- Before adjusting scanning, adjust printing (p.4-60).
- To adjust scanning, use the A4 test chart.

Adjusting Registration

1. Place the test chart on the exposure glass. Make sure that the test chart is aligned with the rear and left scales on the exposure glass.
2. Make a copy.

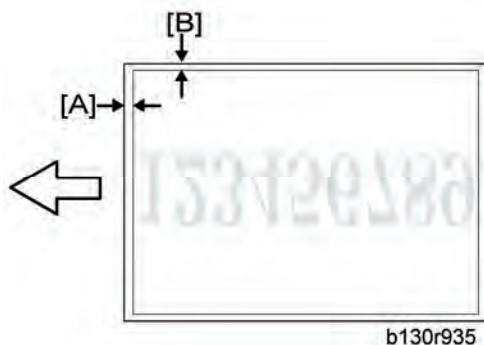

3. Measure the distance between the leading edge of the image area and the leading edge of the paper [A].

↓ Note

- The diagram shows the paper on the copy tray. Note that the paper is output with the face down.
4. Adjust the leading-edge scan registration. (SP4-010-001).

Adjusting Copy Image Area

SP	Specification
SP4-010-001 (LE Scan Regist)	0 ± 2 mm

5. Measure the distance between the side edge of the image area and the side edge of the paper [B].
6. Adjust the side-to-side registration (SP4-011-001).

SP	Specification
SP4-011-001 (S-to-S Scan Regist)	0 ± 2 mm

Adjusting Magnification



1. Place the test chart on the exposure glass. Make sure the test chart is aligned with the rear and left scales on the exposure glass.
2. Make a copy.
3. Compare the copy with the original.
4. Adjust the main-scan and sub-scan magnifications. The original image [A] is magnified in the main-scan direction [B] or in the sub-scan direction [C] when you specify a larger value.

Note

- The diagrams show the paper on the copy tray. Note that the paper is output with the face down.

SP	Specification
SP4-009-001 (Main Scan Mag)	± 1.0%
SP4-008-001 (Sub Scan Mag)	± 1.0%

Scan Auto Adjustment

This procedure adjusts the standard white density level. Adjust the standard white density after any of the following maintenance work:

- Replacing the standard white plate
 - Replacing the BICU
 - Replacing the lens block
 - Executing the memory clear (SP5-801-002 [basic model], SP5-998-001 [other models]).
1. Place 10 sheets of new A4 paper on the exposure glass.
 2. Close the platen cover.
 3. Activate the SP mode.
 4. Select Copy SP4-428.
 5. Specify "1" and press the OK key. The copier automatically adjusts the standard white density.

4.14.3 DF IMAGE ADJUSTMENT

Note

- Perform the adjustment procedure in this section only when the ARDF is installed on the copier.

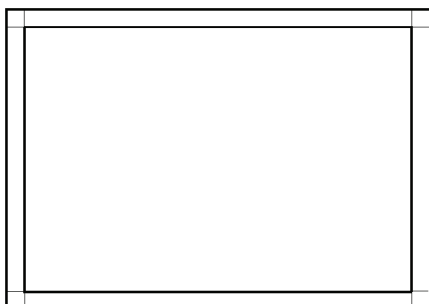

b130r967

1. Make a temporary test chart as shown in the above diagram. Use the "A4/8.5 x 11" paper to make it.
2. Place the temporary test chart on the ARDF.
3. Make a copy.

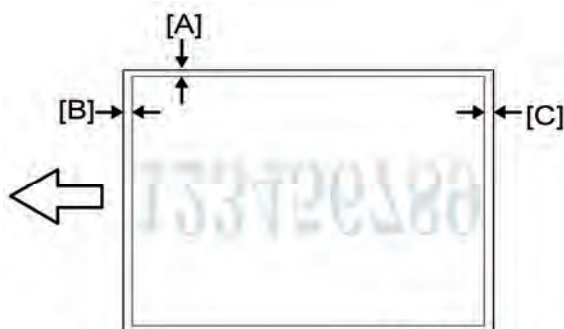

b130r941

4. Measure the distance between the side edge of the image area and the side edge of the paper [A].
(The diagram shows the paper on the copy tray. Note that the paper is output with the face down.)
5. Adjust the side-to-side registration (S to S/Front Regist: SP6-006-001, S to S/Rear Regist: SP6-006-004). The image area moves to the rear side of the copier when you specify a larger value.
6. Measure the distance between the leading of the image area and the leading edge of the paper [B].
7. Adjust the leading edge registration (Leading Regist: SP6-006-002). The image area moves to the right side of the copier when you specify a larger value.
8. Measure the distance between the trailing edge of the image area and the trailing edge of

the paper [C].

9. Adjust the erased area on the trailing edge (Trailing Erase: SP6-006-003).
10. Compare the copy with the original.
11. Adjust the sub-scan magnification (SP6-006-005). The specification is $\pm 1.0\%$.

SYSTEM MAINTENANCE REFERENCE

REVISION HISTORY		
Page	Date	Added/Updated/New
		None

5. SYSTEM MAINTENANCE REFERENCE

5.1 SERVICE PROGRAM

★ Important.

- Do not let the user access the SP mode or the SSP mode. Only service representatives are allowed to access these modes. The machine operation is NOT guaranteed after any person other than service representatives accesses the SP mode.

5.1.1 SP TABLES

See "Appendices" for the following information:

- Service Program Mode Tables

5.1.2 USING SP AND SSP MODES

The following two modes are available:

- SP Mode (Service Program Mode): The SP Mode includes the programs that are necessary for standard maintenance work.
- SSP Mode (Special SP Mode): The SSP Mode includes SP-Mode programs and some special programs. You need some extra knowledge to use these special programs. For details, consult your supervisor.

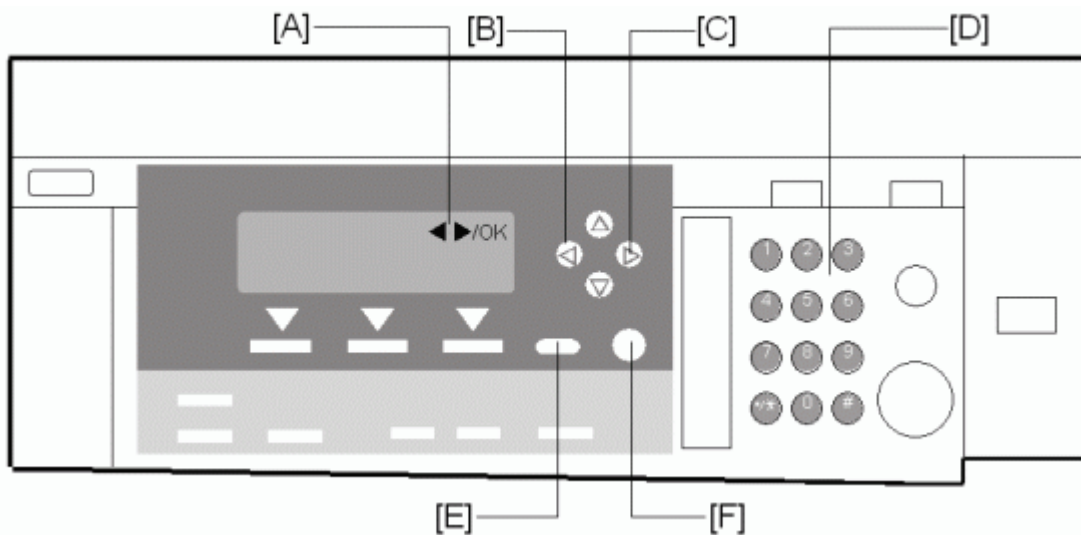

Starting SP Mode

For details, ask your supervisor.

Selecting Programs



- When a blinking underscore (or several blinking underscores) is displayed, you can type a number from the numeric keypad [D].
- When the sign "◀ /OK" [A] is displayed upper right corner, you can scroll through the menu by pressing the left-arrow key [B] or the right-arrow key [C]. To select program, press the OK key [F].

Specifying Values

1. After locating a program, press the OK key. A blinking underscore (or several blinking underscores) indicates which value you can change. The value in parentheses is the default value of the menu.
2. Type a necessary value from the numeric keypad. To switch between positive (plus) and negative (minus) values, press the  key.
3. To validate the value, press the OK key. To cancel the value, press the escape key [E].

Activating Copy Mode

You can activate the copy mode while the SP mode is running. When you do so, the copier outputs images or patterns that help you adjust the SP setting.

1. Press the  key. The copy mode is activated.
2. Specify copy settings and press the  key.
3. To return to the SP mode, press the  key.

Note

- You cannot end the SP mode while the copy mode is activated.

Quitting Programs/Ending (S) SP Mode

Press the  key or the escape key to quit the program. You can end the SP mode by pressing one of these keys several times.

Conventions used in the tables:

- Asterisk (*): The settings are saved in the NVRAM. Most of them return to the default values when you execute SP5-801-002. CTL indicates that the data is contained in NVRAM on the controller board.
- DFU: The program is for design/factory use only. Do not change the settings.
- Brackets ([]): The brackets enclose the setting range, default value, and minimum step with unit ([Minimum to Maximum / **Default** / Step]).

5.2 USING SP MODE

5.2.1 NVRAM DATA UPLOAD/DOWNLOAD

Uploading Content of NVRAM to an SD card

Follow this procedure to upload SP code settings from NVRAM to an SD card.



- This data should always be uploaded to an SD card before the NVRAM is replaced.
1. Before switching the machine off, execute SP 5990-1 (SMC Print). You will need a record of the NVRAM settings if the upload fails.
 2. Turn off the main power of the copier.
 3. Remove the interface cover ( x 1).
 4. Insert the SD card into the service slot 2, then turn on the main power of the copier.
 5. Execute SP 5824-1 (NVRAM Data Upload) then press the "Execute" key.

- When uploading is finished, a file is copied to an NVRAM folder on the SD card. The file is saved to the path and filename:

NVRAM¥<serial number>.NV

Here is an example with Serial Number "B0700017":

NVRAM¥B0700017.NV

6. In order to prevent an error during the download, be sure to mark the SD card that holds the uploaded (saved) data with the number of the machine from which the data was uploaded (saved).



- NVRAM data from more than one machine can be uploaded (saved) to the same SD card.
7. Turn off the main power, and then remove the SD card from the slot 2.
 8. Reassemble the machine.

Downloading an SD Card to NVRAM

Follow this procedure to download (save) SP data from an SD card to the NVRAM in the machine.

- If the SD card with the NVRAM data is damaged, or if the connection between the controller and BICU is defective, the NVRAM data download may fail.
 - If the download fails, repeat the download procedure.
 - If the second attempt fails, enter the NVRAM data manually using the SMC print you created before uploading the NVRAM data. (🖨️ above procedure)
1. Turn off the main power of the copier.
 2. Remove the interface cover 2 (🔧 x 1).
 3. Insert the SD card with the NVRAM data into the service slot 2.
 4. Turn on the main power of the copier.
 5. Execute SP 5825-1 (NVRAM Data Download) and press the “Execute” key.
 6. Turn off the main power of the copier, and then remove the SD card from the slot 2.
 7. Reassemble the machine.

↓ Note

- In order for the NVRAM data to download successfully, the serial number of the file on the SD card must match the serial number of the machine. If the serial numbers do not match, the download will fail.

This procedure downloads (saves) the following data to the NVRAM:

- Total Count
- C/O, P/O Count

5.2.2 FIRMWARE UPDATE PROCEDURE

This section illustrates how to update the firmware of the GW machine (the machine with the optional controller box).

To update the firmware for the GW machine, you must have the new version of the firmware downloaded onto an SD (Secure Digital) Card. The SD Card is inserted into the uppermost slot on the right side of the controller box, viewed from the back of the machine.

Before You Begin...

An SD card is a precision device, so always observe the following precautions when handling SD cards:

- Always switch the machine off before inserting an SD card. Never insert the SD card into the slot with the power on.
- When the power is switched on, never remove the SD card from the service slot.
- Never switch the machine off while the firmware is downloading from the SD card.
- Store SD cards in a safe location where they are not exposed high temperature, high humidity, or exposure to direct sunlight.
- Always handle SD cards with care to avoid bending or scratching them. Never drop an SD card or expose it to other shock or vibration.

Keep the following points in mind while you are using the firmware update software:

- “Upload” means to send data from the machine to the SD card, and “download” means to send data from the SD card to the machine.
- To select an item on the LCD screen, press the appropriate key on the operation panel, or press the appropriate number key on the 10-key pad of the operation panel.
- Before starting the firmware update procedure, always make sure that the machine is disconnected from the network to prevent a print job for arriving while the firmware update is in progress.

Firmware Update Procedure

Note

- Before beginning the following, first confirm which firmware version(s) are currently installed in the machine with SP7-801-255.

-SD Card Preparation-

- Format an SD card with, for example, SD Formatter v1.1.
- Create a "romdata" folder on the card.
- Create the following folders within the "romdata" folder: B121, B620, B622, B658, B681, B685
- Download the firmware from the server and store the files in the folder with the corresponding model code on the SD card.

Example:

File B1215540B should be stored in the "B121" folder, whereas files B6585902B, B6585903B, and B6585905B should be stored in the "B658" folder.

-Firmware Update-

Note

- Do not put multiple machine firmware programs on the same SD card. Copy the only model firmware you want.
- Turn off the main power switch.
 - If the machine is connected to a network, disconnect the network cable from the copier.
 - Remove the interface cover ( x 1)
 - With the label on the SD card facing the rear side of the machine, insert the SD card into the slot 2 on the controller box. Slowly push the SD card into the slot so it locks in place.
 - Make sure the SD card is locked in place.
(To remove the SD card, push it in to unlock the spring lock and then release it so it pops out of the slot.)
 - Switch the main power switch on. After about 5 seconds, the LCD will display "Please wait..." Then, about 60 seconds later, the LCD will display "Program UpDate Menu P.01" on the first line and the name of the firmware on the second line (e.g. System/Copy).



- Press the "OK" key to select a module.

Using SP Mode

- To scroll through the menus, press the Δ or ∇ keys [A].

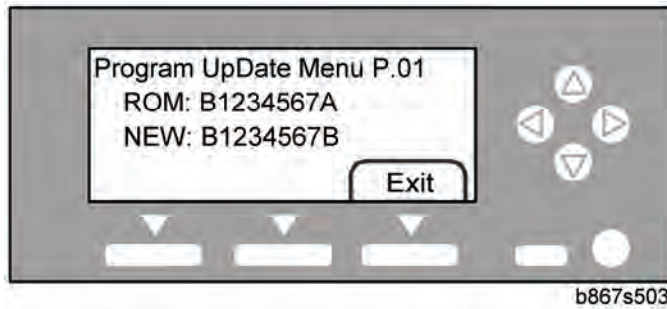

- To view the firmware version, press the right key. "ROM" is the information on the current firmware. "NEW" is the information on the firmware in the SD card.
- To return to the menu, press the \leftarrow key.
- To select the module, press the OK key.
- To scroll through the module name, the serial number, and the version, press the \leftarrow key or \rightarrow key.
- If you wish to install the following firmware simultaneously, press the START key. The scroll keys can be used to confirm that this firmware has been selected (highlighted with a dark background).

[Engine, FCU, Scanner, Printer, Printer Font, Security Module]

★ Important

- Please note that the following firmware **cannot** be updated simultaneously. The update procedure must be repeated for each individually.
- System/Copy, ServiceCardNetFile, ServiceCardNIB, ServiceCardFAX, ServiceCardWebSystem.

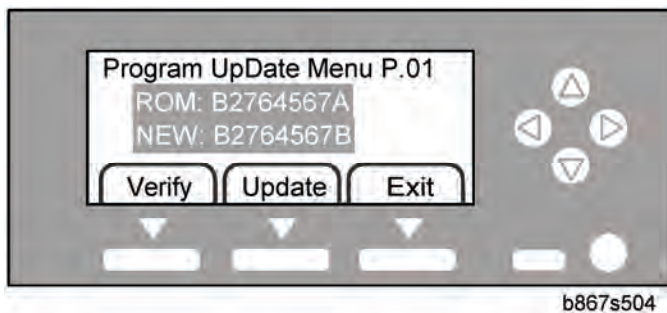

- When you have selected a module, the text lines are highlighted, and the "Verify" key and the "Update" key are displayed.
8. Select a module and press the "Update" key.

★ Important

- Do **NOT** press the “Verify” key.
9. The firmware update program starts and the message "Loading" is displayed.
 - The update will begin, and then will take a few minutes to complete. The LCD will initially display, “Updating... ***_-----“.
 - When the update is completed, the LCD display will change to “Update done” or “Updated / Power Off On”.

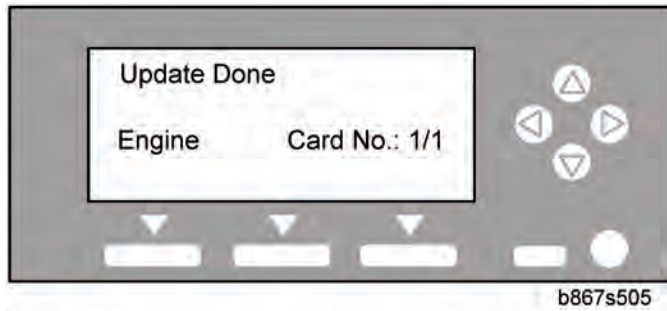

10. Check that the message "Update Done" is displayed.

-Confirmation-

1. Turn the main power switch off and on.
 - The LCD will display “Please wait...” for about 60 seconds, after which it will return to the “Program UpDate Menu” screen.
2. Repeat Steps 1-8 above until all firmware updates are complete.
3. Turn the main power switch off.
4. Remove the SD card from the lower slot on the controller by pushing on the card to release the spring lock.

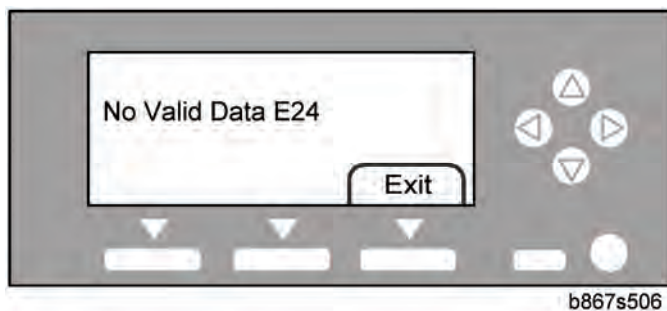

If an error occurs, the error code is displayed. For a list of information on error codes, see the following table.



Code	Cause	Necessary Action
E20	Physical address mapping error	<ul style="list-style-type: none"> ▪ Insert the SD card correctly. ▪ Use another SD card
E22	Decompression error	<ul style="list-style-type: none"> ▪ Store correct data in the SD card.
E23	Update program error	<ul style="list-style-type: none"> ▪ Update controller program. ▪ Replace the controller.
E24	SD card access error	<ul style="list-style-type: none"> ▪ Insert the SD card correctly. ▪ Use another SD card.
E31	Download data inconsistency*	<ul style="list-style-type: none"> ▪ Insert the SD card that was used when the previous update procedure is interrupted.
E32	Download data inconsistency*	<ul style="list-style-type: none"> ▪ Insert the SD card that stores the correct data.
E33	Version data error	<ul style="list-style-type: none"> ▪ Store the correct data in the SD card.
E34	Locale data error	<ul style="list-style-type: none"> ▪ Store the correct data in the SD card.
E35	Machine model data error	<ul style="list-style-type: none"> ▪ Store the correct data in the SD card.
E36	Module data error	<ul style="list-style-type: none"> ▪ Store the correct data in the SD card.
E40	Engine program error**	<ul style="list-style-type: none"> ▪ Store the correct data in the SD card. ▪ Replace BICU.
E42	Operation panel program error*	<ul style="list-style-type: none"> ▪ Store the correct data in the SD card. ▪ Replace the operation panel board.
E44	Controller program error*	<ul style="list-style-type: none"> ▪ Store the correct data in the SD card. ▪ Replace the controller board.
E50	Authentication error	<ul style="list-style-type: none"> ▪ Store the correct data in the SD card.

*You need to reinstall the program.

If the firmware update program is interrupted (for example, by a power failure), keep the SD card inserted and turn the mains switch off and on. The firmware update program restarts. If you do not do so, the message "Reboot after Card insert" is displayed when you turn the main switch on.

5.2.3 TEST PATTERN PRINT (SP5-902-001)

Executing Test Pattern Printing

1. Specify the pattern number and press the OK key.
2. Press the copy start key. The copy mode is activated.
3. Specify copy settings and press the  key.
4. To return to the SP mode, press the  key.

Test Patterns

Test Patterns Using VCU	
No.	Pattern
0	(No print)
1	Vertical Lines (Single Dot)
2	Horizontal Lines (Single Dot)
3	Vertical Lines (Double Dot)
4	Horizontal Lines (Double Dot)
5	Grid Pattern (Single Dot)
6	Grid Pattern (Double Dot)
7	Alternating Dot Pattern
8	Isolated One Dot
9	Black Band (Horizontal)
10	Trimming Area
11	Argyle Pattern (Single Dot)
12	Grayscales (Horizontal)
13	Grayscales (Vertical)
14	Grayscales (Vertical/Horizontal)

Test Patterns Using VCU	
15	Grayscales (Vertical/Horizontal Overlay)
16	Grayscales With White Lines (Horizontal)
17	Grayscales with White Lines (Vertical)
18	Grayscales with White Lines (Vertical/Horizontal)

Test Patterns Using IPU	
No.	Pattern
30	Vertical Lines (Single Dot)
31	Horizontal Lines (Single Dot)
32	Vertical Lines (Double Dot)
33	Horizontal Lines (Double Dot)
34	Isolated Four Dots
35	Grid Pattern (Double Dot)
36	Black Band (Vertical, 1024 Dots)
37	Grayscales (Horizontal, 512 Dots)
38	Grayscales (Vertical, 256 Dots)
39	ID Patch
40	Cross
41	Argyle Pattern (128-Dot Pitch)
42	Square Gradation (64 Grades)
43	Square Gradation (256 Grades)
44	Grayscales (Horizontal, 32-Dot Width)
45	Grayscales (Vertical, 32-Dot Width)
47	A4 Gradation Patches 1 (128 Grades)

Test Patterns Using IPU	
48	A4 Gradation Patches 2 (128 Grades)
49	Trimming Area (A4)

Test Patterns Using SBU	
No.	Pattern
51	Grid Pattern (double dot)
52	Gray Scale 1 (256 grades)
53	Gray Scale 2 (256 grades)

Test Patterns Using PCI*1	
No.	Pattern
61	S2M: Grid Pattern
62	S2M: Argyle Pattern
63	S2M: Argyle Pattern
64	S2M: Argyle Pattern + Image*2
65	S2M: Grid Pattern
66	S2M: Grid Pattern + Image
67	S2M: Argyle Pattern
68	S2M: Argyle Patten + Image
69	Engine: Grid Pattern
70	Engine: Argyle Pattern

*1: The PCI is available to the models with the controller box.

*2: The original image on the exposure glass is printed behind the test pattern.

5.2.4 MEMORY CLEAR

GW Machine

The GW machine (the machine with the optional controller box) stores the engine data in the NVRAM on the BICU, and stores the other data in the NVRAM on the optional controller. To distinguish between the engine data and the other data, see SP5-801-003 through 015. This service program (SP5-801) handles the controller data. Any data that is not handled by SP5-801 is the engine data. The data in the BICU NVRAM (engine data) is cleared by SP5-998-001 while the data in the controller NVRAM (controller data) is cleared by SP5-801-xxx (for exceptions, see "Exceptions" as described below).

Machine	Data	NVRAM	Cleared by	Remarks
GW	Engine data	BICU	SP5-998-001	Any data other than controller data
	Controller data	Controller	SP5-801-xxx	SCS, IMH, MCS, Copier application, Fax application, Printer application, Scanner application, Web service/network application, NCS, R-Fax, DCS, UCS

Exceptions

SP5-998-001 clears most of the settings and counters stored in the NVRAM on the BICU (the values return to their default values). However, the following settings are not cleared:

- SP5-807 (Area Selection)
- SP5-811-001 (Serial Num Input [Code Set])
- SP5-811-003 (Serial Num Input [ID2 Code Display])
- SP5-812-001 (Service TEL [Telephone])
- SP5-812-002 (Service TEL [Facsimile])
- SP5-907 (Plug & Play)
- SP7 (Data Log)
- SP8 (History)

Use SP5-998-001 after you have replaced the BICU NVRAM or when the BICU NVRAM data is corrupted. When the program ends normally, the message "Completed" is displayed. When you have replaced the controller NVRAM or when the controller NVRAM data is corrupted, use SP5-801-001. The message is the same as the basic machine.

Memory Clear Procedure

1. Print out all SMC data lists (▶ p.5-17 "SMC Print (SP5-990)").
2. Do SP5-998-001.
3. Press the OK key.
4. Select "Execute." The messages "Execute?" followed by "Cancel" and "Execute" are displayed.
5. Select "Execute."
6. When the program has ended normally, the message "Completed" is displayed. If the program has ended abnormally, an error message is displayed.
7. Turn the main switch off and on.
8. Adjust the printer and scanner registration and magnification (* "Copy Adjustment" in the chapter "Replacement and Adjustment").
9. Refer to the SMC lists, and enter any values that differ from the factory settings.
Double-check the values for SP4-901.
10. Adjust the standard white level (SP4-428).
11. Initialize the TD sensor (SP 2-214).
12. Check the copy quality and the paper path.

5.2.5 MACHINE NO. SETTING (SP5-811-001)

Specifying Characters

SP5-811-001 specifies the serial number. For the machine with the optional controller, you use the numeric keypad and the optional operation panel.

GW Machine

You can use the numeric keypad to type numbers. In addition, you can use the operation panel to type other characters. When you press the "ABC" key, the letter changes as follows: A → B → C. To input the same letter two times, for example "AA," you press the "ABC" key, the "Space" key, and the "ABC" key. To switch between uppercase letters and lowercase letters, press the "Shift" key.

Serial Number and NVRAM

Serial numbers are stored in the NVRAM before shipment and are not cleared. You must specify a serial number after you replace the NVRAM.

5.2.6 SMC PRINT (SP5-990)

SP5-990 outputs machine status lists.

1. Select SP5-990.
2. Select a menu:
 - GW machine: 001 All (Data List), 002 SP (Mode Data List), 003 User Program, 004 Logging Data, 005 Diagnostic Report, 006 Non-Default, 007 NIB Summary, 008 Net File Log, 021 Copier User Program, 022 Scanner SP, 023 Scanner User Program, 040 Parts Alarm Counter Print, 064 Normal Count Print, 065 User Code Counter, 066 Key Operator Counter, 067 Contact List Print, 069 Heading1 print, 071 Heading3 print, 072 Group List Print, 128 ACC Pattern, 129 User Color Pattern, or 160:ACC Pattern Scan

↓ Note

- The output given by the menu "Big Font" is suitable for faxing.
3. Press the "Execute" key.
 - GW machine: The machine status list is output.
 4. To return to the SP mode, press the  key.

5.2.7 ID SENSOR ERROR ANALYSIS (SP2-221)

The image quality may become very bad when the ID sensor does not operate properly. However, there is no such SC code that indicates ID-sensor malfunction; instead, SP2-221 shows you some information on the ID sensor. Check this information when the image quality is not very good.

The table lists the information shown with SP2-221 (ID Sensor Error Analysis).

SP	Error condition	Possible cause	Remarks
SP2-221-1 Vsg (VG in the display)	$V_{sg} < 2.5V$ or $(V_{sg} - V_{sp}) < 1.00V$	<ul style="list-style-type: none"> ▪ ID sensor defective ▪ ID sensor dirty ▪ Drum not charged 	-
SP2-221-2 Vsp (VP in the display)	$V_{sp} > 2.5V$ or $(V_{sg} - V_{sp}) < 1.00V$	<ul style="list-style-type: none"> ▪ Toner density very low ▪ ID sensor pattern not created 	-
SP2-221-3 Power (PW in the display)	$V_{sg} < 3.5V$ when maximum power (979) is applied	<ul style="list-style-type: none"> ▪ ID sensor defective ▪ ID sensor dirty ▪ Drum not get charged 	Power source for the ID-sensor light
SP2-221-4 Vsdp	No Error Conditions		-
SP2-221-5 Vt	$V_t > 4.5V$ or $V_t < 0.2V$	<ul style="list-style-type: none"> ▪ TD sensor defective 	-
SP2-221-6 Vts	-	-	-

5.3 FAX SERVICE TABLES

See "Appendices" for the following information:

- Fax System Service Mode
- Bit Switches
- NCU Parameters
- Dedicated Transmission Parameters
- Service RAM Addresses

TROUBLESHOOTING

REVISION HISTORY		
Page	Date	Added/Updated/New
		None

6. TROUBLESHOOTING

6.1 SC TABLES

6.1.1 SUMMARY

There are four levels of service call conditions.

Level	Definition	Reset Procedure
A	To prevent possible damage, the machine does not operate until the service representative resets the SC code.	Activate the SP mode, and turn the main power switch off and on.
B	Turning the main power switch off and on resets the SC code if the error is caused by incorrect sensor detection.	Turn the main power switch off and on.
C	The machine operates as usual excluding the unit related to the service call.	Turn the main power switch off and on.
D	The SC history is updated. The machine operates as usual.	No SC code is displayed. Only the SC history is updated.

↓ Note

- If a problem involves circuit boards, see if you can solve the problem by disconnecting and reconnecting all connectors before deciding to replace a circuit board.
- If a problem involves a motor lock, check the mechanical load before deciding to replace a motor or sensor.
- If working on a fax-equipped machine, switching power off and on may cause loss of data stored in the memory.

6.1.2 ENGINE SC CODE DESCRIPTIONS

No. Definition		Symptom	Possible Cause
101	B	Exposure Lamp Error	
		The scanner has scanned the white plate, but cannot detect the white level.	<ul style="list-style-type: none"> ▪ Defective exposure lamp ▪ Defective exposure lamp stabilizer ▪ Defective exposure lamp connector ▪ Unclean scanner mirror ▪ Scanner mirror out of position ▪ Defective SBU board ▪ Defective SBU connector ▪ Lens block out of position ▪ Incorrect position or width of white plate scanning (SP4-015)
120	B	Scanner home position error 1	
		The scanner home position sensor does not detect the scanner leaving the home position.	<ul style="list-style-type: none"> ▪ Defective scanner home position sensor ▪ Defective scanner drive motor ▪ Defective scanner home position sensor connector ▪ Defective scanner drive motor connector ▪ Defective BICU board

No. Definition		Symptom	Possible Cause
121	B	Scanner home position error 2	
		The scanner home position sensor does not detect the scanner coming back to the home position.	<ul style="list-style-type: none"> ▪ Defective scanner home position sensor ▪ Defective scanner drive motor ▪ Defective scanner home position sensor connector ▪ Defective scanner drive motor connector ▪ Defective BICU board
141	B	SBU black level correction error	
		<ul style="list-style-type: none"> ▪ The automatic SBU adjustment has failed to correct the black level three times at the pre-offset adjustment. ▪ The automatic SBU adjustment has failed to correct the black level ten times at the PGA adjustment. ▪ The automatic SBU adjustment has failed to correct the black level ten times at the offset adjustment. 	<ul style="list-style-type: none"> ▪ Defective SBU board
142	B	SBU white/black level correction error	
		The automatic SBU adjustment has failed to correct the white level ten times at the PGA adjustment.	<ul style="list-style-type: none"> ▪ Defective exposure lamp ▪ Unclean white plate ▪ Incorrect position or width of white plate scanning (👉 SP4-015) ▪ Defective SBU board

No. Definition		Symptom	Possible Cause
144	B	Communication Error between BICU and SBU	
		The BICU cannot correctly establish communication with the SBU.	<ul style="list-style-type: none"> ▪ Loose connection of the flat cable between the BICU and the SBU ▪ Defective flat cable between the BICU and the SBU ▪ Defective BICU ▪ Defective SBU
145	D	Automatic SBU adjustment error	
		The white levels of the white plate and the white paper are extraordinarily different during the Scan Auto Adjustment (SP4-428-001).	<ul style="list-style-type: none"> ▪ Defective exposure lamp ▪ Unclean white plate ▪ Incorrect position or width of white plate scanning (SP4-015) ▪ Defective BICU board ▪ Defective SBU board
193	B	Image transfer error	
		Scanned images are not transferred to the controller memory within one minute.	<ul style="list-style-type: none"> ▪ Defective BICU board ▪ Defective controller board
198	B	Memory address error	
		The BICU does not receive the memory address report from the controller within one minute.	<ul style="list-style-type: none"> ▪ Inconsistency between the BICU firmware and the controller firmware ▪ Defective BICU ▪ Defective controller

No. Definition		Symptom	Possible Cause
302	B	Charge roller current leak	
		The polling module detects a current leak of the charge roller.	<ul style="list-style-type: none"> ▪ Defective charge roller ▪ Defective high voltage supply board ▪ Loose connection of the PCU
320	B	Polygonal mirror motor error	
		The polygon mirror motor does not reach the operating speed within 10 seconds. Or, the polygon mirror motor remains out of the operating speed for 0.2 second after reaching the operating speed.	<ul style="list-style-type: none"> ▪ Defective polygon mirror motor ▪ Loose connection between the polygonal mirror motor and the BICU ▪ Defective cable between the BICU and the polygon mirror motor ▪ Defective BICU
321	B	No laser writing signal (F-GATE) error	
		The polling module does not detect the laser writing signal (F-GATE) asserting after the laser crosses 5 mm from the start point on the drum surface.	<ul style="list-style-type: none"> ▪ Defective BICU ▪ Loose connection on the fax controller or the printer controller ▪ Defective fax controller or printer controller
322	B	Laser synchronization error	
		The main scan synchronization detector does not detect the laser signal for 0.5 second.	<ul style="list-style-type: none"> ▪ Toner bottle not installed ▪ Loose connection between the LD unit and the BICU ▪ Defective cable between the BICU and LD unit ▪ LD unit out of position ▪ Defective LD unit ▪ Defective BICU

No. Definition		Symptom	Possible Cause
390	B	TD sensor error	
		The BICU detects the TD sensor outputting extraordinary voltage (less than 0.2 V or more than 4.0 V) 10 times consecutively.	<ul style="list-style-type: none"> ▪ Defective TD sensor ▪ Loose connection of the PCU
391	B	Development bias leak	
		The polling module detects a current leak of the development bias.	<ul style="list-style-type: none"> ▪ Loose connection of the PCU ▪ Defective high voltage supply board
392	B	Developer initialization error	
		The ID sensor does not detect a correct pattern during developer initialization (■ 2-214-001).	<ul style="list-style-type: none"> ▪ Defective ID sensor ▪ Insufficient developer ▪ Defective drum operation ▪ Defective development roller operation ▪ Loose connection of the PCU ▪ Insufficient voltage for the charge roller
401	B	Transfer roller leak error (positive electrode)	
		The feedback voltage of the transfer roller is insufficient.	<ul style="list-style-type: none"> ▪ Defective high voltage supply board ▪ Loose connection of the PCU ▪ Incorrect installation of the transfer unit or the separation unit ▪ Defective transfer roller

No. Definition		Symptom	Possible Cause
402	B	Transfer roller leak error (negative electrode)	
		The feedback voltage of the transfer roller is insufficient.	<ul style="list-style-type: none"> ▪ Defective high voltage supply board ▪ Loose connection of the PCU ▪ Incorrect installation of the transfer unit or the separation unit ▪ Defective transfer roller
500	B	Main motor error	
		The main motor does not reach its operation speed within 0.7 second. Or, the main motor remains out of its operation speed for 0.7 second after reaching the operation speed.	<ul style="list-style-type: none"> ▪ Overload ▪ Defective main motor
541	A	Fusing thermistor open error	
		The fusing temperature remains lower than the specified temperature by 20 degrees Celsius.	<ul style="list-style-type: none"> ▪ Defective thermistor ▪ Incorrect installation of the thermistor ▪ Defective power supply unit ▪ Loose connectors
542	A	Fusing temperature warm-up error	
		The fusing temperature rises 7 degrees or less in two seconds; and this continues 5 times consecutively. Or, the fusing temperature is not detected within 25 or 35 seconds.	<ul style="list-style-type: none"> ▪ Defective thermistor ▪ Incorrect installation of the thermistor ▪ Defective fusing lamp ▪ Defective power supply unit

No. Definition		Symptom	Possible Cause
543	A	Fusing overheat error 1	
		The fusing temperature detected by the thermistor is 230°C or higher for one second.	<ul style="list-style-type: none"> ▪ Defective thermistor ▪ Defective power supply unit
544	A	Fusing overheat error 2	
		The fusing temperature detected by the monitor circuit is 250°C or higher for one second.	<ul style="list-style-type: none"> ▪ Defective thermistor ▪ Defective power supply unit
545	A	Fusing lamp overheat error	
		After the fusing temperature reaches the target, the fusing lamp remains on for 12 seconds.	<ul style="list-style-type: none"> ▪ Defective thermistor ▪ Incorrect installation of the thermistor ▪ Defective power supply unit
546	A	Unstable fusing temperature	
		While the fusing lamp is on, the fusing temperature varies 50°C or more within one second; and this occurs two consecutive times.	<ul style="list-style-type: none"> ▪ Defective thermistor ▪ Incorrect installation of the thermistor ▪ Defective power supply unit
547	B	Zero cross signal malfunction	
		The zero cross signal is not detected within five seconds after the main power switch is turned on. Or, the zero cross signal is not detected within one second after operation begins.	<ul style="list-style-type: none"> ▪ Defective power supply unit ▪ Defective BICU

No. Definition		Symptom	Possible Cause
559	A	Consecutive fusing jam	
		The paper jam counter for the fusing unit reaches 3 times. The paper jam counter is cleared if the paper is fed correctly. This SC is activated only when SP1159-001 is set to "1" (default "0").	<ul style="list-style-type: none"> ▪ Paper jam in the fusing unit.
590	B	Exhaust fan motor error	
		The exhaust fan motor is locked for five seconds.	<ul style="list-style-type: none"> ▪ Loose connection of the exhaust fan motor ▪ Overload
760	B	ADF gate error 1	
		The ADF sends the FGATE signal before it is requested to scan originals.	<ul style="list-style-type: none"> ▪ Defective ADF board ▪ Defective input/output board ▪ Loose connection
761	B	ADF gate abnormal 2	
		The ADF does not send the FGATE signal within 30 seconds after the ADF starts scanning.	<ul style="list-style-type: none"> ▪ Defective ADF connector ▪ Defective SBU board
762	B	ADF gate abnormal 3	
		The ADF continues to send the FGATE signal for more than 60 seconds after the ADF starts scanning.	<ul style="list-style-type: none"> ▪ Defective ADF connector ▪ Defective SBU board

No. Definition		Symptom	Possible Cause
901	B	Mechanical total counter error	
		The polling module does not detect the mechanical total counter.	<ul style="list-style-type: none"> ▪ Defective mechanical total counter ▪ Defective BICU ▪ Loose connection
903	B	Engine total counter error	
		The checksum of the total counter is not correct.	<ul style="list-style-type: none"> ▪ Defective NVRAM on the BICU
954	B	Printer application program error	
		The printer application program does not become ready when the printer application program is necessary.	<ul style="list-style-type: none"> ▪ Defective application program
955	B	Image transfer error	
		The BICU requests the controller to transfer image data; but the controller does not become ready.	<ul style="list-style-type: none"> ▪ Defective application program
964	B	Status error (laser optics housing unit)	
		The optics-housing unit does not become ready within 17 seconds after a request.	<ul style="list-style-type: none"> ▪ Defective software

No. Definition	Symptom	Possible Cause
980	<p data-bbox="379 398 783 432">Controller-engine inconsistency</p> <p data-bbox="379 757 815 835">The controller is incompatible with the engine.</p>	<p data-bbox="850 477 1270 555">One of the following controllers is installed to the basic model:</p> <ul data-bbox="850 566 1310 790" style="list-style-type: none"> <li data-bbox="850 566 1310 611">▪ The controller of the MFP model <li data-bbox="850 622 1310 701">▪ The controller of the copier/facsimile model <li data-bbox="850 712 1310 790">▪ The controller of the printer/scanner/copier model <p data-bbox="850 813 1302 936">The controller of the optional printer/scanner is installed to one of the following models:</p> <ul data-bbox="850 947 1241 1126" style="list-style-type: none"> <li data-bbox="850 947 1241 992">▪ The MFP model <li data-bbox="850 1003 1241 1037">▪ The copier/facsimile model <li data-bbox="850 1048 1241 1126">▪ The printer/scanner/copier model
981	<p data-bbox="379 1169 555 1202">NVRAM error</p> <p data-bbox="379 1339 759 1417">An error occurs during engine NVRAM check.</p>	<ul data-bbox="850 1238 1289 1507" style="list-style-type: none"> <li data-bbox="850 1238 1289 1283">▪ Defective NVRAM <li data-bbox="850 1294 1289 1373">▪ Loose connection between the BICU and the NVRAM <li data-bbox="850 1384 1289 1462">▪ Incorrect installation of the NVRAM <li data-bbox="850 1473 1289 1507">▪ Defective BICU
982	<p data-bbox="379 1556 603 1590">Localization error</p> <p data-bbox="379 1680 807 1848">The localization information in the nonvolatile ROM and in the NVRAM is different (SP5-807-001).</p>	<ul data-bbox="850 1624 1310 1892" style="list-style-type: none"> <li data-bbox="850 1624 1310 1803">▪ Localization setting not specified (The main power switch is turned on for the first time after the NVRAM is replaced.) <li data-bbox="850 1814 1310 1848">▪ Incorrect localization setting <li data-bbox="850 1859 1310 1892">▪ Defective NVRAM

No. Definition		Symptom	Possible Cause
984	B	Print image transfer error	
		Print images are not transferred.	<ul style="list-style-type: none"> ▪ Defective controller ▪ Defective BICU ▪ Loose connection between the controller and the BICU

6.1.3 GW SC CODE DESCRIPTIONS

SC6xx

No. Definition		Symptom	Possible Cause/Countermeasure
632	C	MF accounting device error 1	
		The machine sends a data frame. → No normal end signal returns. → This symptom happens three times.	<ul style="list-style-type: none"> ▪ Defective or broken line between machine and device
633	C	MF accounting device error 2	
		The machine is communicating with the accounting device. → The break signal returns.	<ul style="list-style-type: none"> ▪ Defective or broken line between machine and device
634	C	MF accounting device error 3	
		A backup RAM error is reported from the accounting device.	<ul style="list-style-type: none"> ▪ Defective accounting device controller ▪ Defective battery in the accounting device
635	C	MF accounting device error 4	
		A battery voltage error is reported from the accounting device.	<ul style="list-style-type: none"> ▪ Defective accounting device controller ▪ Defective battery in the accounting device

No. Definition	Symptom	Possible Cause/Countermeasure
636	SD Card Error	
-001	B	Expanded authentication module error
		<p>There is no expanded authentication module in the machine.</p> <p>The SD card or the file of the expanded authentication module is broken.</p> <p>There is no DESS module in the machine.</p>
-002	B	Version error
		The version of the expanded authentication module is not correct.
650	Communication error of the remote service modem (Cumin-M)	
-001	C	Authentication error
		The authentication for the Embedded RCG-M fails at a dial up connection.
-004	C	Incorrect modem setting
		Dial up fails due to the incorrect modem setting.
-005	C	Communication line error
		The supplied voltage is not sufficient due to the defective communication line or defective connection.

No. Definition	Symptom		Possible Cause/Countermeasure
651	Incorrect dial up connection		
	An unexpected error occurs when the modem (RCG-M) tries to call the center with a dial up connection.		
-001	D	Program parameter error	<ul style="list-style-type: none"> ▪ Software bug. <ol style="list-style-type: none"> 1. No action required because this SC does not interfere with operation of the machine.
-002	D	Program execution error	
670	Engine startup error		
	B	<p>Just after the main power is turned on or the machine is recovering from auto off mode, the engine ready signal assertion fails.</p> <p>Just after the main power is turned on, the engine does not respond.</p>	<ul style="list-style-type: none"> ▪ Poor connection between the BICU and controller board ▪ Defective BICU ▪ Defective controller board
672	Controller-to-operation panel communication error at startup		
	B	<p>After powering on the machine, communication between the controller and operation panel does not begin, or the communication is interrupted after a normal startup.</p>	<ul style="list-style-type: none"> ▪ Controller stalled ▪ Controller board installed incorrectly ▪ Defective controller board ▪ Operation panel connector loose or defective ▪ Poor connection of DIMM and optional boards on the controller board <ol style="list-style-type: none"> 1. Check the setting of SP5875-001. If the setting is set to "1 (OFF)", change it to "0 (ON)".

SC8xx

No. Definition	Symptom		Possible Cause/Countermeasure
817	Monitor Error		<ul style="list-style-type: none"> ▪ OS Flash ROM data defective; change the controller firmware ▪ SD card data defective; use another SD card
	B	This is a file detection and electronic file signature check error when the boot loader attempts to read the self-diagnostic module, system kernel, or root system files from the OS Flash ROM, or the items on the SD card in the controller slot are false or corrupted.	
819	Kernel stop		
	Due to a control error, a RAM overflow occurred during system processing. One of the following messages was displayed on the operation panel.		
[5032]	B	HAIC-P2 error	<ul style="list-style-type: none"> ▪ System program defective ▪ Controller board defective ▪ Optional board defective <ol style="list-style-type: none"> 1. Replace controller firmware
[6261]	B	init died	
[0696e]	B	Process error	
[0766d]	B	VM full error	
[554C]	B	USB error	
[----]	B	The others	

No. Definition	Symptom	Possible Cause/Countermeasure	
820	Self-Diagnostic Error: CPU		
	B	<ul style="list-style-type: none"> ▪ [0001-0015] [000A-000D]: Detailed error code 	
		<p>During the boot monitor program and self-diagnostic, any exception or cut-in are not supposed to happen. If these happen, it is defined as SC.</p> <ul style="list-style-type: none"> ▪ Defective CPU device ▪ Defective boot monitor program or self-diagnostic program <ol style="list-style-type: none"> 1. Replace the controller board. 2. Reinstall the system firmware. 	
	B	[00FF]: Detailed error code	
		Cache access error in the CPU	<ul style="list-style-type: none"> ▪ Defective CPU ▪ Defective local bus <ol style="list-style-type: none"> 1. Turn the main power switch off and on. 2. Reinstall the system program. 3. Replace the controller board.
	B	[0601, 0602, 0605, 0606, 0607, 0609]: Detailed error code	
		Exceptional command does not operate even though it is executed on purpose.	<ul style="list-style-type: none"> ▪ Defective CPU devices <ol style="list-style-type: none"> 1. Replace the controller board.
	B	[060A-060E]: Detailed error code	
		Cut-in command does not operate when it is executed	<ul style="list-style-type: none"> ▪ Defective CPU devices ▪ Defective ASIC devices <ol style="list-style-type: none"> 1. Replace the controller board.
	B	[0610]: Detailed error code	
		Timer cut-in does not operate even though it is set	<ul style="list-style-type: none"> ▪ Defective CPU devices <ol style="list-style-type: none"> 1. Replace the controller board.
B	[0612]: Detailed error code		

No. Definition	Symptom	Possible Cause/Countermeasure
820	Cut-in in ASIC occurs.	<ul style="list-style-type: none"> ▪ Defective ASIC ▪ Defective devices in which ASIC detects cut-in. <ol style="list-style-type: none"> 1. Replace the controller board.
	[06FF]: Detailed error code	
	B The pipeline clock frequency rate is different from the prescribed value.	<ul style="list-style-type: none"> ▪ Defective CPU devices ▪ Mode bit data error, which is used for initializing CPU. <ol style="list-style-type: none"> 1. Replace the controller board.
	[0702]: Detailed error code	
	B The result when the program is executed in the command cache is different from desirable value.	<ul style="list-style-type: none"> ▪ Insufficient CPU cache ▪ Insufficient memory process speed <ol style="list-style-type: none"> 1. Replace the controller board. 2. Replace the RAM DIMM.
	[0709, 070A]: Detailed error code	
	B Even you write the data in the only cache of memory, the data is actually written in another area (not cache) of memory.	<ul style="list-style-type: none"> ▪ Defective CPU devices ▪ Incorrect SPD ▪ Boot mode setting error <ol style="list-style-type: none"> 1. Replace the controller board. 2. Replace the RAM DIMM.
	[0801, 0804, 0807, 0808, 0809, 80A]: Detailed error code	
	B An error occurs when checking the TLB.	<ul style="list-style-type: none"> ▪ Defective CPU devices <ol style="list-style-type: none"> 1. Replace the controller board.
	[4002-4005]: Detailed error code	
	B The calculation error in the CPU occurs.	<ul style="list-style-type: none"> ▪ Defective CPU <ol style="list-style-type: none"> 1. Replace the CPU.

No. Definition	Symptom	Possible Cause/Countermeasure
821	Self-Diagnostic Error: ASIC	
[0B00]	B	ASIC error
		The write-&-verify check error has occurred in the ASIC.
[0B06]	B	ASIC not detected
		The ASIC of the I/O is not detected.
[0D05]	B	Timer error between ASIC and CPU
		The CPU checks if the ASIC timer works properly compared with the CPU timer. If the ASIC timer does not function in the specified range, this SC code is displayed.
[50A1]	B	Video bridge device (ASIC) error 1
		The CPU does not detect the video bridge device.
[50A2]	B	Video bridge device (ASIC) register error 1
		The CPU detects the video bridge device, but detects error data from the video bridge device.

No. Definition	Symptom		Possible Cause/Countermeasure
822	Self-diagnostic error: HDD (Hard Disk Drive)		
	[XXXX]: Detailed error code		
When the main switch is turned on or starting the self-diagnostic, the HDD stays busy for the specified time or more.			
[3003]	C	Timeout error	<ul style="list-style-type: none"> ▪ Loose connection ▪ Defective HDD ▪ Defective controller
[3004]	C	Command error	<ol style="list-style-type: none"> 1. Check that the HDD is correctly connected to the controller. 2. Replace the HDD. <ul style="list-style-type: none"> ▪ Replace the controller.
823	Self-diagnostic Error: NIB		
[6101]	MAC address check sum error		
	C	The result of the MAC address check sum does not match the check sum stored in ROM.	<ul style="list-style-type: none"> ▪ Defective controller <ol style="list-style-type: none"> 1. Replace the controller.
[6104]	PHY IC error		
	C	The PHY IC on the controller cannot be correctly recognized.	Same as SC823-[6101]
[6105]	PHY IC loop-back error		
	C	An error occurred during the loop-back test for the PHY IC on the controller.	Same as SC823-[6101]

No. Definition	Symptom	Possible Cause/Countermeasure
824 [1401]	B	Self-diagnostic Error: NVRAM
		The controller cannot recognize the standard NVRAM installed or detects that the NVRAM is defective.
826	B	Self-diagnostic Error: RTC/Optional NVRAM
		[1501]: Clock error
		<ul style="list-style-type: none"> ▪ An RTC device is recognized, and the difference between the RTC device and the CPU exceeds the defined limit. ▪ No RTC device is recognized.
	B	[15FF]: RTC not detected
The RTC device is not detected.	<ul style="list-style-type: none"> ▪ NVRAM without RTC installed ▪ Backup battery discharged <ol style="list-style-type: none"> 1. Replace the NVRAM with another NVRAM with an RTC device. 	

Trouble-shooting

No. Definition	Symptom	Possible Cause/Countermeasure	
827	Self-diagnostic Error: RAM		
[0201]	B	Verification error	
		Error is detected during a write/verify check for the standard RAM (SDRAM DIMM).	<ul style="list-style-type: none"> ▪ Loose connection ▪ Defective SDRAM DIMM ▪ Defective controller <ol style="list-style-type: none"> 1. Replace the SDRAM DIMM. 2. Replace the controller.
[0202]	B	Resident memory error	
		The SPD values in all RAM DIMM are incorrect or unreadable.	<ul style="list-style-type: none"> ▪ Defective RAM DIMM ▪ Defective SPD ROM on RAM DIMM ▪ Defective 12C bus <ol style="list-style-type: none"> 1. Replace the RAM DIMM.
828	Self-diagnostic Error: ROM		
[0101]	B	Boost lap code error	
		The boot monitor and OS program stored in the ROM DIMM is checked. If the check sum of the program is incorrect, this SC code is displayed.	<ul style="list-style-type: none"> ▪ Defective ROM DIMM ▪ Defective controller <ol style="list-style-type: none"> 1. Replace the ROM DIMM. 2. Replace the controller.
829	B	Self-diagnostic Error: Optional RAM	
		Verify error for optional RAM.	
		[0301] Verification error (Slot 1)	<ul style="list-style-type: none"> ▪ Make sure that the resident RAM is installed in the correct slot. ▪ Make sure the optional RAM is installed in the correct slot (Slot 0)
		[0302] Composition error (Slot 1)	

No. Definition	Symptom		Possible Cause/Countermeasure
835	Self-diagnostic error: Centronic device		
[1102]	C	Loopback connector is connected but check results in an error.	<ul style="list-style-type: none"> ▪ IEEE1284 connector error ▪ Centronic loopback connector defective <ol style="list-style-type: none"> 1. Replace the controller board.
[110C]	C	Loopback connector is connected but check results in an error.	<ul style="list-style-type: none"> ▪ ASIC device error ▪ IEEE1284 connector error ▪ Centronic loopback connector defective <ol style="list-style-type: none"> 1. Replace the controller board.
[1120]	C	Centronic loopback connector is not connected for detailed self-diagnostic test.	<ul style="list-style-type: none"> ▪ Centronic loopback connector not connected correctly ▪ Centronic loopback connector defective ▪ ASIC device defective <ol style="list-style-type: none"> 1. Replace the controller board.
838 [2701]	Self-diagnostic Error: Clock Generator		
	B	A verify error occurred when setting data was read from the clock generator via the I2C bus.	<ul style="list-style-type: none"> ▪ Defective clock generator ▪ Defective I2C bus ▪ Defective I2C port on the CPU <ol style="list-style-type: none"> 1. Replace the controller board.
839	USB NAND Flash ROM error		
[9101]	B	The ID of the USB NAND Flash ROM cannot be read.	<ul style="list-style-type: none"> ▪ Defective controller board <ol style="list-style-type: none"> 1. Replace the controller board.
[9110]	B	The USB NAND Flash ROM is disconnected.	

No. Definition	Symptom	Possible Cause/Countermeasure
853	Wireless card startup error	<ul style="list-style-type: none"> ▪ Loose connection between the wireless card and the connection board
	The machine starts up. → The IEEE802.11b card connection board is recognized. → The wireless LAN card or bluetooth card is not recognized.	
854	Wireless card access error	<ul style="list-style-type: none"> ▪ Loose connection between the wireless card and the connection board
	The machine has been reading the data from the card. → The machine loses access to the card; the wireless LAN card or bluetooth card connection board is still recognized.	
855	Wireless card error	<ul style="list-style-type: none"> ▪ Defective wireless card
	Some illegal data is found in the card.	
856	Wireless card connection board error	<ul style="list-style-type: none"> ▪ Defective wireless card connection board
	An error is detected in the wireless LAN card or bluetooth card connection board.	
857	USB I/F Error	<ul style="list-style-type: none"> ▪ Defective controller 1. Check the USB connections, and make sure that they are securely connected. 2. Replace the controller board.
	USB interface error is detected.	

No. Definition	Symptom	Possible Cause/Countermeasure
858	HDD Encryption unit error 1	
	A serious error occurs when data is encrypted to update an encryption key with the HDD encryption unit.	
[0]	Encryption key acquisition error: The controller fails to get a new encryption key.	<ul style="list-style-type: none"> ▪ Defective controller board <ol style="list-style-type: none"> 1. Replace the controller board.
[1]	Encryption key setting for HDD error: The controller fails to copy a new encryption key to the HDD.	<ul style="list-style-type: none"> ▪ Defective SATA chip on the controller board <ol style="list-style-type: none"> 1. Replace the controller board.
[2]	A NVRAM data encryption error 1: An error occurs while the NVRAM data is encrypted.	<ul style="list-style-type: none"> ▪ Defective NVRAM on the controller board <ol style="list-style-type: none"> 1. Replace the NVRAM.
[30]	NVRAM data encryption error 2: An error occurs before the NVRAM data is encrypted.	<ul style="list-style-type: none"> ▪ Defective controller board <ol style="list-style-type: none"> 1. Replace the controller board.
[31]	Other error: A serious error occurs while the data is encrypted.	<ul style="list-style-type: none"> ▪ Same as SC991

No. Definition	Symptom		Possible Cause/Countermeasure
859	HDD Encryption unit error 2		
	A serious error occurs when the HDD data is encrypted to update an encryption key with the HDD encryption unit.		
[8]		HDD check error: The HDD is not correctly installed.	<ul style="list-style-type: none"> ▪ No HDD installed ▪ Unformatted HDD ▪ The encryption key on the controller is different from the one on the HDD <ol style="list-style-type: none"> 1. Install the HDD correctly. 2. Initialize the HDD.
[9]	C	Power failure during the data encryption: The data encryption (NVRAM and HDD) has not been completed.	<ul style="list-style-type: none"> ▪ Power failure during the data encryption <ol style="list-style-type: none"> 1. Initialize the HDD.
[10]		Data read/write error: The DMAC error is detected twice or more.	<ul style="list-style-type: none"> ▪ Same as SC863
860	HDD: Initialization error		
	B	The controller detects that the hard disk fails.	<ul style="list-style-type: none"> ▪ HDD not initialized ▪ Defective HDD <ol style="list-style-type: none"> 1. Reformat the HDD. 1. Replace the HDD.
862	Bad sector number error		
	B	The number of bad sectors in the HDD (image data area) goes over 101.	<ul style="list-style-type: none"> ▪ Defective HDD <ol style="list-style-type: none"> 1. Format the HDD with SP5-832-002. 2. Replace the HDD.

No. Definition	Symptom	Possible Cause/Countermeasure
863	HDD: Read error	
	C The data stored in the HDD cannot be read correctly.	<ul style="list-style-type: none"> ▪ Defective HDD ▪ Defective controller <ol style="list-style-type: none"> 1. Replace the HDD. 2. Replace the controller.
864	HDD: CRC error	
	C While reading data from the HDD or storing data in the HDD, data transmission fails.	<ul style="list-style-type: none"> ▪ Defective HDD <ol style="list-style-type: none"> 1. Replace the HDD.
865	HDD: Access error	
	C An error is detected while operating the HDD.	<ul style="list-style-type: none"> ▪ Defective HDD <ol style="list-style-type: none"> 1. Replace the HDD.
866	SD card authentication error	
	C A digital license error of an SD card application is detected.	<ul style="list-style-type: none"> ▪ SD card data has corrupted. <ol style="list-style-type: none"> 1. Store correct data in the SD card.
867	SD card error	
	B An application SD card is removed from the boot slot while an application is activated.	<ul style="list-style-type: none"> ▪ An application SD card is ejected.

No. Definition	Symptom	Possible Cause/Countermeasure
868	<p>B</p> <p>SD card access error (-13 to -3: File system error, other number: Device error)</p> <p>An error report is sent from the SD card reader.</p>	<ul style="list-style-type: none"> ▪ SD card not inserted correctly ▪ SD card defective ▪ Controller board defective <ol style="list-style-type: none"> 1. For a file system error, format the SD card on PC. 2. For a device error, turn the main switch off and on. 3. Remove and re-install the SD card. 4. Replace the SD card. 5. Replace the controller.
870	<p>C</p> <p>Address book data error</p> <p>The address book in the hard disk is accessed. → An error is detected in the address book data; address book data is not read; or data is not written into the address book.</p>	<ul style="list-style-type: none"> ▪ Data corruption ▪ Defective hard disk ▪ Defective controller software <ol style="list-style-type: none"> 1. Replace the hard disk (the user codes and counters are recovered when the main switch is turned on if those data are stored in Smart Device Monitor for Admin).
		<p> Note</p> <ul style="list-style-type: none"> ▪ To recover from the error, do any of the following countermeasures: ▪ Format the address book by using SP5-846-050 (all data in the address book—including the user codes and counters—is initialized).

No. Definition	Symptom		Possible Cause/Countermeasure
876	Log Data Error		
	An error was detected in the handling of the log data at power on or during machine operation. This can be caused by switching the machine off while it is operating.		
-001	C	Log Data Error 1	<ul style="list-style-type: none"> ▪ Damaged log data file in the HDD <ol style="list-style-type: none"> 1. Initialize the HDD with SP5832-004.
-002	C	Log Data Error 2	<ul style="list-style-type: none"> ▪ An encryption module not installed <ol style="list-style-type: none"> 1. Disable the log encryption setting with SP9730-004 ("0" is off.) 2. Install the DESS module.
-003	C	Log Data Error 3	<ul style="list-style-type: none"> ▪ Invalid log encryption key due to defective NVRAM data <ol style="list-style-type: none"> 1. Initialize the HDD with SP5832-004. 2. Disable the log encryption setting with SP9730-004 ("0" is off.)
-004	C	Log Data Error 4	<ul style="list-style-type: none"> ▪ Unusual log encryption function due to defective NVRAM data <ol style="list-style-type: none"> 1. Initialize the HDD with SP5832-004.

No. Definition		Symptom	Possible Cause/Countermeasure
-005	C	Log Data Error 5	<ul style="list-style-type: none"> ▪ Installed NVRAM or HDD which is used in another machine <ol style="list-style-type: none"> 1. Reinstall the previous NVRAM or HDD. 2. Initialize the HDD with SP5832-004.
-099	C	Log Data Error 99	<ul style="list-style-type: none"> ▪ Other than the above causes <ol style="list-style-type: none"> 1. Ask your supervisor.
TPM system authentication error			
878	C	The system firmware is not authenticated by TPM (security chip).	<ul style="list-style-type: none"> ▪ Incorrect updating for the system firmware ▪ Defective flash ROM on the controller board <ol style="list-style-type: none"> 1. Replace the controller board.
File Format Converter (MLB) error			
880	B	A request to get access to the MLB was not answered within the specified time.	<ul style="list-style-type: none"> ▪ MLB defective

SC9xx

900	B	Electronic total counter error	
		The value of the total counter is out of the normal range.	<ul style="list-style-type: none"> ▪ Defective NVRAM
920	C	Printer error	
		An application error that stops the machine operation is detected.	<ul style="list-style-type: none"> ▪ Defective software 1. Unexpected hardware resource (e.g., memory shortage)
921	C	Printer font error	
		A necessary font is not found in the SD card when the printer application starts.	<ul style="list-style-type: none"> ▪ A necessary font is not found in the SD card. ▪ The SD card data is corrupted. 1. Check that the SD card stores correct data.
925	Net file error		
	C	The management file for net files is corrupted; net files are not normally read. Netfiles: Jobs to be printed from the document server using a PC and the DeskTopBinder software	<ul style="list-style-type: none"> ▪ Defective hardware ▪ Data corruption ▪ Defective software

		Software performance error	
		<p>The software attempted to perform an unexpected operation.</p> <p> Note</p> <ul style="list-style-type: none"> When this error occurs, the file name, address, and data will be stored in NVRAM. This information can be checked by using SP7-403. See the data and the situation in which this SC occurs. Then report the data and conditions to your technical control center. 	<ul style="list-style-type: none"> Software defective Internal parameter incorrect Insufficient working memory
990	B		
		Software continuity error	
		<p>The software attempted to perform an unexpected operation. However, unlike SC990, the process can keep on running.</p>	<ul style="list-style-type: none"> Logged only; the machine can continue to operate
991	D		
		Undefined error	
		<p>An error not controlled by the system occurred (the error does not come under any other SC code).</p>	<ul style="list-style-type: none"> Defective software program
992	B		

997	C	Application function selection error	
		The application selected by a key press on the operation panel does not start or ends abnormally.	<ul style="list-style-type: none"> ▪ Software for that application is defective ▪ An option required by the application (RAM, DIMM, board) is not installed. ▪ Too complicated nest of the fax group address <ol style="list-style-type: none"> 1. As for the fax operation problem, simplify the nest of the fax group address.
998	B	Application start error	
		After switching the machine on, the application does not start within 60 s. (No applications start or end normally.)	<ul style="list-style-type: none"> ▪ Software for that application is defective ▪ An option required by the application (RAM, DIMM, board) is not installed. <ol style="list-style-type: none"> 1. Check the setting of SP5875-001. If the setting is set to "1 (OFF)", change it to "0 (OFF)".

6.2 ELECTRICAL COMPONENT DEFECTS

6.2.1 SENSOR/SWITCH

Sensor	Connector	Message	Remarks
Registration Sensor	CN127	Paper jam	-
	SN		
Paper End Sensor	CN129	Load paper	-
	SN		
Bypass Paper End Sensor	CN130	(None)	The machine cannot detect paper on the bypass tray.
	SN		
Paper Path Sensor	CN128	Paper jam	-
	SN		
Exit Sensor	CN128	Paper jam	-
	SN		
Image Density (ID) Sensor	CN132	(None)	Print quality may become worse.
	SN		
Toner Density (TD) Sensor	CN123	SC901	The connector is shared with the mechanical total counter.
	PCU	Reset PCU correctly	-
Scanner HP Sensor	CN126	SC120	-
	SN	SC120	-
Platen Cover Sensor	CN126	SC120	-
	SN	(None)	The copier does not warm up when you open the platen cover.

Sensor	Connector	Message	Remarks
DF Guide Open Sensor	DF CN103	Paper jam	-
	SN	(None)	-
DF Original Set Sensor	DF CN103	Paper jam	-
	Sensor	(None)	Originals are not detected.
DF Registration Sensor	DF CN103	Paper jam	-
	SN		Originals are correctly transported.
Inverter Sensor	DF CN103	Paper jam	-
	SN	(None)	-
Exit Sensor	DF CN103	Paper jam	-
	SN		-
Front Door Switch	CN114	Right door open	-
	SW	Front/Right door open	The message depends on which circuit is open (white → front; blue → right).
Right Door Switch	CN114	Right door open	-
	SW	Right door open	-

CNxxx: The connector on the BICU board.

DF CNxxx: The connector on the DF connection board.

SN: The connector on the sensor.

SW: The connector on the switch.

PCU: The connector on the PCU.

6.2.2 BLOWN FUSE CONDITIONS

All of these fuses are on the power supply unit.

Fuse	Rating		At main switch ON
	120 V	220 – 240 V	
FU1	15A/125V	8A/250 V	No response
FU2	5A/125V	2.5A/250V	No response

6.2.3 BICU LED DISPLAY

Number	Function
LED2	LED2 blinks in normal operation.

6.3 CARD SAVE FUNCTION

6.3.1 OVERVIEW

Card Save:

- The Card Save function is used to save print jobs received by the printer on an SD card with no print output. Card Save mode is toggled using printer Bit Switch #1 bit number 4. Card Save will remain enabled until the SD card becomes full, or until all file names have been used.
- Captures are stored on the SD card in the folder /prt/cardsave. File names are assigned sequentially from PRT00000.prn to PRT99999.prn. An additional file PRT.CTL will be created. This file contains a list of all files created on the card by the card save function.
- Previously stored files on the SD card can be overwritten or left intact. Card Save SD has “Add” and “New” menu items.
 - **Card Save (Add):** Appends files to the SD Card. Does not overwrite existing files. If the card becomes full or if all file names are used, an error will be displayed on the operation panel. Subsequent jobs will not be stored.
 - **Card Save (New):** Overwrites files in the card's /prt/cardsave directory.

Limitation:

- Card Save cannot be used with PjL Status Readback commands. PjL Status Readbacks will not work. In addition they will cause the Card Save to fail.

6.3.2 PROCEDURE

1. Turn the main power switch OFF.
2. Insert the SD card into the service slot of the controller board. Then turn the power ON.



- To determine which slot is the service slot, please see the service manual.

3. Enter SP mode.
4. Select "Printer SP".
5. Select "Service Mode" and press "OK" button.
6. Select "1.001 Bit Switch" and press "OK" button.

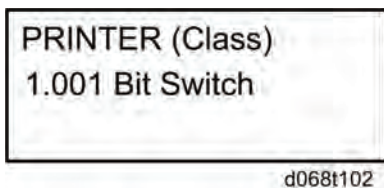

7. Press "OK" button again.

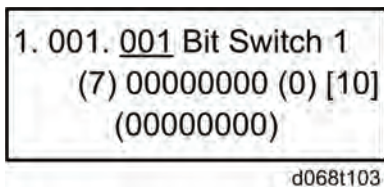

8. Use the numeric key "4" to turn bit 4 ON. The result should look like: **00010000**. By doing this Card Save option will appear in "List/Test Print".

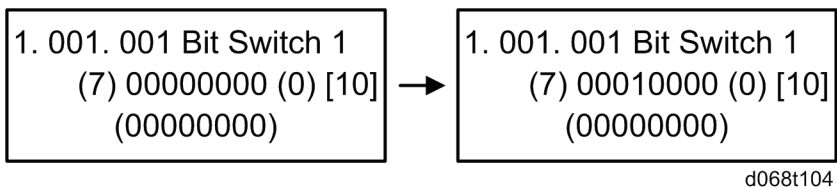

9. Press the "Return" button several times to exit SP Mode.
10. Press the "F2" button.
11. Use the arrow key and select "Printer Features".

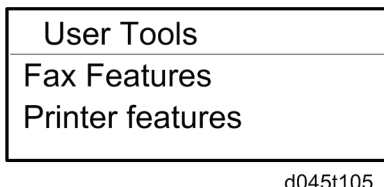

12. Use the arrow key and select "List/Test Print".

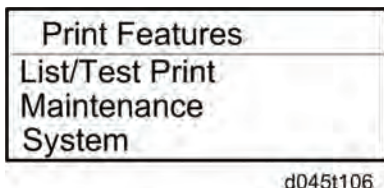

13. Use the arrow key and select “Cardsave (ADD) or Cardsave (New).

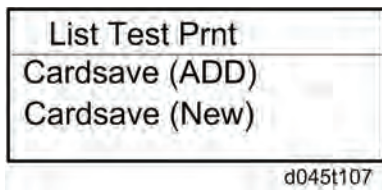

14. To enable the newly configured settings, select “switch” button and then press the “Return” button to exit the “List/Test Print” menu.
15. Send a job to the printer.
16. As soon as the printer receives the data, it will be stored on the SD card automatically with no print output. Nothing is displayed on the screen indicating that a Card Save operation was successful.
17. Press the “Return” button to exit Card Save mode.
18. Change the Bit Switch Settings back to the default **00000000**.
19. Remove the SD card after main power switch is turned off.

Error Messages

Card Save error messages:

- **Init error:** A card save process (i.e. card detection, change to kernel mode) failed to initialize.
- **Card not found:** Card cannot be detected in the slot.
- **No memory:** Insufficient working memory to process the job.
- **Write error:** Failed to write to the card.
- **Other error:** An unknown error occurred.

If an error occurs, pressing “OK” will cause the device to discard the job and return to the ready state.

6.4 FAX TROUBLESHOOTING GUIDE

See "Appendices" for the following information:

- Fax Error Codes
- IFAX Troubleshooting
- IP-Fax Troubleshooting

ENERGY SAVING

REVISION HISTORY		
Page	Date	Added/Updated/New
		None

7. ENERGY SAVING

7.1 ENERGY SAVE

7.1.1 ENERGY SAVER MODES

Customers should use energy saver modes properly, to save energy and protect the environment.

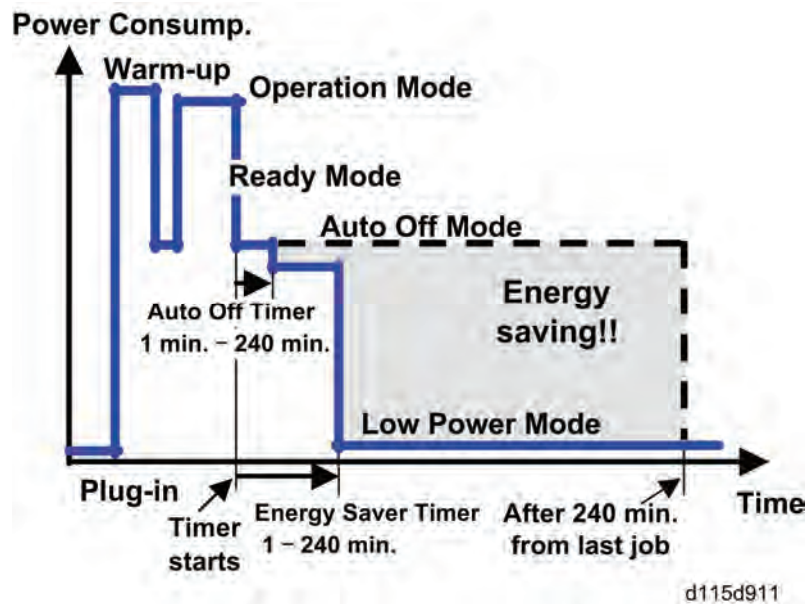

The area shaded grey in this diagram represents the amount of energy that is saved when the timers are at the default settings. If the timers are changed, then the energy saved will be different. For example, if the timers are all set to 240 min., the grey area will disappear, and no energy is saved before 240 min. expires.

Timer Settings

The user can set these timers with User Tools (System settings > Timer setting)

- Auto off timer (1 – 240 min): Auto Off/Sleep Mode. Default settings: 1 minute
- Energy saver timer (1 – 240 min): Low Power Mode. Default setting: 15 minutes

Normally, Auto Off timer < Energy Saver timer. But, for example, if Energy Saver timer < or = Auto Off timer, the machine goes immediately to Low Power mode when the Energy Saver timer expires. It skips the Auto Off mode.

Example

- Auto Off: 1 min.
- Low power: 15 min.

The machine goes to Low Power mode after 1 minute. Off/Sleep mode is not used.



Recommendation

We recommend that the default settings should be kept.

- If the customer requests that these settings should be changed, please explain that their energy costs could increase, and that they should consider the effects on the environment of extra energy use.
- If it is necessary to change the settings, please try to make sure that the Auto Off timer is not too long. Try with a shorter setting first, such as 30 min., then go to a longer one (such as 60 min.) if the customer is not satisfied.
- If the timers are all set to the maximum value, the machine will not begin saving energy until 240 minutes has expired after the last job. This means that after the customer has finished using the machine for the day, energy will be consumed that could otherwise be saved.
- If you change the settings, the energy consumed can be measured using SP8941, as explained below.

7.1.2 ENERGY SAVE EFFECTIVENESS

SP 8941 (Machine Status) keeps a record of the amount of time that the machine spends in each mode.

- 8941-001: Operating mode
- 8941-002: Standby mode
- 8941-003: Panel off mode
- 8941-004: Low power mode
- 8941-005: Off/sleep mode

With this data, and the power consumption values from the specifications, we can estimate the amount of energy that is used by the machine.

This should only be used as a reference value, because the power consumption specifications are measured in a controlled environment with a constant power supply.

To get an exact measurement at the customers site, a watt meter must be used to measure the actual energy consumed.

To use SP8941 to calculate the energy consumed:

- At the start of the measurement period, read the values of SP8941 001 to 005.
- At the end of the measurement period, read the values of SP8941 001 to 005 again.
- Find the amount of time spent in each mode (subtract the earlier measurement from the later measurement).
- Multiply this by the power consumption spec for each mode.
- Convert the result to kWh (kilowatt hours)

Here is an example calculation.

Machine Date	Power Consumption (W): Data: a	SP8941: Machine Status	Start Time: (min.) Data: b	End Time: (min.) Data: c	Time Differences (Data:b - Data: c) (min.) Data: d	Power Consumption (Data:a x Data:d) (Wmin.) Data: e
① Operating mode	1081.8	001: Operating Time	21089.0	21386.0	297.0	321294.6
② Ready mode (stand by)	214.0	002: Standby Time	306163.0	308046.0	1883.0	402962.0
③ Energy mode (Panel off)	214.0	003: Energy Save Time	71386.0	75111.0	3725.0	797150.0
④ Low power mode	153.0	004: Low power Time	154084.0	156340.0	2256.0	345168.0
⑤ Off/Sleep mode	7.0	005: Off mode Time	508776.0	520377.0	11601.0	81207.0
Total Time of Data: d (min.)					19762.0	
Total Time of Data: d/60min. (Hour)					329.37	
Total Power Consumption of Data: e (Wmin.)						1947781.60
Total Power Consumption of Data: e /60min./1000W (KWH)						32.46

7.2 PAPER SAVE

7.2.1 EFFECTIVENESS OF DUPLEX/COMBINE FUNCTION

Duplexing and the combine functions reduce the amount of paper used. This means that less energy overall is used for paper production, which improves the environment.

1. Duplex:

Reduce paper volume in half!



d062d102

2. Combine mode:

Reduce paper volume in half!



d062d100

3. Duplex + Combine:

Using both features together can further reduce paper volume by 3/4!



d062d101

To check the paper consumption, look at the total counter and the duplex counter.

The total counter counts all pages printed.

- For one duplex page, the total counter goes up by 2.
- For a duplex job of a three-page original, the total counter goes up by 3.

The duplex counter counts pages that have images on both sides.

- For one duplex page, the duplex counter goes up by 1.
- For a duplex job of a three-page original, the duplex counter will only increase by 1, even though two sheets are used.

Recommendation

Please explain the above features to the customers, so that they can reduce their paper usage.

Model S-C4.5

- Total counter: SP 8581-001
- Duplex counter: SP 8411-001
- Single-sided with combine mode: SP 8421-004
- Duplex with combine mode: SP 8421-005

The following table shows paper savings and how the counters increase for some simple examples of single-sided and duplex jobs

Duplex mode:

Originals	Simplex Sheet used	Duplex Sheets used	Paper Saved	Total counter SP8501-001	Duplex counter SP8411-001
1	1	1	0	1	0
2	2	1	1	2	1
3	3	2	1	3	1
4	4	2	2	4	2
5	5	3	2	5	2
10	10	5	5	10	5
20	20	10	10	20	10

If combine mode is used, the total and duplex counters work in the same way as explained previously. The following table shows paper savings and how the counters increase for some simple examples of duplex/combine jobs.

2 in 1 mode:

Originals	Simplex Sheet used	Duplex Sheets used	Paper Saved	Total counter SP8501-001	Duplex counter SP8421-004
1	1	1	0	1	1
2	2	1	1	1	1
3	3	2	1	2	2
4	4	2	2	2	2
5	5	3	2	3	2
10	10	5	5	5	5
20	20	10	10	10	10

Paper Save

Duplex + 2 in 1 mode:

Originals	Simplex Sheet used	Duplex Sheets used	Paper Saved	Total counter SP8501-001	Duplex counter SP8421-005
1	1	1	0	1	1
2	2	1	1	1	1
3	3	1	2	2	2
4	4	1	3	2	2
5	5	2	3	3	3
6	6	2	4	3	3
7	7	2	5	4	4
8	8	2	6	4	4
9	9	3	6	5	5
10	10	3	7	5	5
11	11	3	8	6	6
12	12	3	9	6	6

D115/D116
SERVICE MANUAL APPENDICES

D115/D116 APPENDICES

TABLE OF CONTENTS

1. APPENDIX: SPECIFICATIONS	1-1
1.1 SPECIFICATIONS	1-1
1.1.1 COPIER	1-1
1.1.2 PRINTER	1-4
1.1.3 SCANNER	1-5
1.1.4 FAX.....	1-6
General	1-6
IFAX Specifications	1-8
IP-FAX Specifications.....	1-10
Fax Unit Configuration.....	1-11
1.1.5 ARDF	1-12
1.1.6 PAPER TRAY UNIT	1-13
1.2 SUPPORTED PAPER SIZES	1-14
1.2.1 ORIGINAL PAPER SIZES	1-14
1.2.2 PAPER FEED	1-16
2. APPENDIX: PREVENTIVE MAINTENANCE TABLES.....	2-1
2.1 MAINTENANCE TABLES	2-1
3. APPENDIX: SP MODE TABLES.....	3-1
3.1 SYSTEM SERVICE MODE.....	3-1
3.1.1 SERVICE MODE TABLES.....	3-1
SP1-XXX (Feed)	3-1
SP2-XXX (Drum).....	3-5
SP4-XXX (Scanner)	3-11
SP5-XXX (Mode).....	3-24
SP6-XXX (Peripherals).....	3-82
SP7-XXX (Data Log)	3-84
SP8-XXX (History)	3-92
3.1.2 INPUT CHECK (SP5-803)	3-117
Conducting Input Check.....	3-117

Input Check Table	3-117
3.1.3 OUTPUT CHECK (SP5-804)	3-119
Conducting Output Check	3-119
Output Check Table	3-119
3.1.4 PRINTER SERVICE MODE.....	3-121
Service Mode Table	3-121
SP Modes Related to Printer Controller	3-126
3.1.5 SCANNER PROGRAM MODE TABLE.....	3-127
Service Table Key	3-127
4. APPENDIX: FAX TROUBLESHOOTING GUIDE	4-1
4.1 FAX ERROR CODES	4-1
4.2 IFAX TROUBLESHOOTING	4-22
4.3 IP-FAX TROUBLESHOOTING	4-25
4.3.1 IP-FAX TRANSMISSION	4-25
Cannot send by IP Address/Host Name.....	4-25
Cannot send via VoIP Gateway	4-27
Cannot send by Alias Fax number.	4-28
4.3.2 IP-FAX RECEPTION	4-29
Cannot receive by IP Address/Host name.....	4-29
Cannot receive by VoIP Gateway.	4-30
Cannot receive by Alias Fax number.	4-31
5. APPENDIX: FAX SERVICE PROGRAM.....	5-1
5.1 SYSTEM SERVICE MODE.....	5-1
5.1.1 SP1-XXX (BIT SWITCHES).....	5-1
5.1.2 SP2-XXX (RAM DATA).....	5-2
5.1.3 SP3-XXX (TEL LINE SETTINGS).....	5-3
5.1.4 SP4-XXX (ROM VERSIONS)	5-4
5.1.5 SP5-XXX (INITIALIZING).....	5-5
5.1.6 SP6-XXX (REPORTS).....	5-6
5.1.7 SP7-XXX (TEST MODES).....	5-8
5.2 BIT SWITCHES	5-9
5.2.1 SYSTEM SWITCHES	5-9
5.2.2 I-FAX SWITCHES.....	5-22
5.2.3 PRINTER SWITCHES	5-30
5.2.4 COMMUNICATION SWITCHES.....	5-36
5.2.5 G3-1 SWITCHES.....	5-44

5.2.6 IP FAX SWITCHES.....	5-54
5.3 NCU PARAMETERS	5-63
5.4 DEDICATED TRANSMISSION PARAMETERS	5-77
5.4.1 PROGRAMMING PROCEDURE	5-77
5.4.2 PARAMETERS	5-78
Fax Parameters.....	5-78
E-mail Parameters	5-82
5.5 SERVICE RAM ADDRESSES	5-86

APPENDIX: SPECIFICATIONS

REVISION HISTORY		
Page	Date	Added/Updated/New
		None

1. APPENDIX: SPECIFICATIONS

1.1 SPECIFICATIONS

1.1.1 COPIER

Configuration:	Desktop
Copy Process:	Laser beam scanning and electro-photographic printing
Originals:	Sheet/Book/Object
Original Size:	Maximum A4 / 8 ¹ / ₂ " x 14" A4 / 8 ¹ / ₂ " x 14" (ARDF)
Copy Paper Size:	Maximum A4 SEF / 8 ¹ / ₂ " x 11" SEF (Copier's paper tray) A4 SEF / 8 ¹ / ₂ " x 14" SEF (Bypass) A4 SEF / 8 ¹ / ₂ " x 14" SEF (Optional paper tray) A4 SEF / 8 ¹ / ₂ " x 14" SEF (Duplex) Minimum A5 LEF / 8 ¹ / ₂ " x 5 ¹ / ₂ " LEF (Copier's paper tray) A6 SEF / 8 ¹ / ₂ " x 5 ¹ / ₂ " (Bypass) A4 SEF / 8 ¹ / ₂ " x 11" SEF (Optional paper tray unit) A4 SEF / 8 ¹ / ₂ " x 11" SEF (Duplex) Custom sizes in the bypass tray: Width: 90 – 216 mm (3.5" – 8.5") Length: 139 – 600mm (5.48" – 23.62")
Copy Paper Weight:	Standard paper tray; optional paper tray: 60 – 90 g/m ² , 16 – 24 lb. Bypass: 60 – 157 g/m ² , 16 – 42 lb. Duplex: 64 – 90 g/m ² , 20 – 24 lb.

Specifications

		A4 Version	LT Version
Reproduction Ratios:	Enlargement	200%	155%
		141%	129%
	Full Size	100%	100%
	Reduction	93%	93%
71%		78%	
50%		65%	
Zoom:	50% to 200%, in 1% steps		
Power Source:	120 V, 60 Hz or 220 – 240 V, 50/60 Hz		
Power Consumption:	Maximum:	900 W or less (EU), 1000 W or less (NA)	
	Energy Saver:	35 W or less	
	Sleep Mode:	10 W or less	
	Off Mode:	None	
Noise Emission:	Sound Power Level		
	Standby	40 dB(A) or less	
	Operating (copier only)	63 dB(A) or less	
	Operating (full-system)	67 dB(A) or less	
Dimensions (W x D x H)	Copier: 485 x 450 x 371 mm (19.4" x 18" x 14.8") With optional paper tray unit: 485 x 454 x 511 mm (18.4" x 17.7" x 20.1")		
Weight:	29 kg (66 lb.) or less		
Resolution:	600 dpi		
Copying Speed in Multicopy Mode (copies/minute):	Memory Copy: 20 cpm (A4 / 8 ¹ / ₂ " x 11"; 100%) DF 1 to 1: 16cpm		
Warm-up Time:	30 seconds or less (at 20°C [68°F])		

First Copy Time:	7.5 seconds or less Note: Measurement conditions <ul style="list-style-type: none"> ▪ From the ready state, with the polygonal mirror motor spinning. ▪ A4/LT copying ▪ From copier's paper tray ▪ 100% size
Copy Number Input:	Numeric keypad, 1 to 99 (increment, decrement)
Manual Image Density:	5 steps
Auto Off Timer	Default: 1 minute Range: 1 to 240 minutes
Energy Saver Timer:	Default: 1 minute Rage: 1 to 240 minutes
Copy Paper Capacity:	Paper Tray: 250 sheets Optional Paper Tray Unit: 500 sheets x 1 Bypass Tray: 100 sheets
Copy-Tray Capacity	250 sheets
Toner Replenishment:	Cartridge replacement (230 g/cartridge)
Toner Yield	7k copies /toner bottle (A4, 6% full black)
Optional Equipment:	Auto reverse document feeder Paper tray unit Anti-condensation heater for paper tray unit

1.1.2 PRINTER

Resolution:	600 dpi (PCL 6/PCL5e/PS3/RPCS) 300 dpi (PCL5e/PS3) 600 dpi (RPCS (XPS))
Printing speed:	20 cpm (A4, 8 1/2" x 11")
Interface:	USB 2.0 interface, Ethernet interface (100BASE-TX/10BASE-T) IEEE1284 IEEE802.11a/g (Wireless LAN) (option) Gigabit Ethernet (option)
Network protocol:	TCP/IP (IPv4, IPv6), IPX/SPX, AppleTalk, RHPP
Printer language:	PJL PCL5e/XL RPCS (XPS) Adobe PS3/PDF (option)
Resident Fonts:	PCL: 45 fonts 13 International fonts PCL option: OCR, Barcode Adobe PS3/PDF: 136 fonts Summary: 4 Arial
Memory:	640 MB
Operating systems supported by this machine:	Windows 2000/XP/Server 2003/Vista/Server2008 MacOS8.6 to 9, MacOSX10.1 or later
Required network cable:	100BASE-TX/10BASE-T shielded twisted-pair (STP, Category/Type5) cable. Gigabit Ethernet- Category6 cable

1.1.3 SCANNER

Scan method	Flatbed scanning
Scan speed * ¹	B/W: 20 pages/ min. [Scan Size: A4 SEF, compression, Resolution 200 dpi] ITU-T No.1 Chart Full Color: 9 pages/ min. [Scan Size: A4 SEF, compression (level3), Resolution 200 dpi] ISO/JIS-SCID N5 Chart
Maximum power consumption	Less than 900 W
Image sensor type	CCD Image Sensor
Scan types	Sheet, book
Interface	Ethernet interface (10BASE-T or 100BASE-TX) IEEE1284 IEEE 802.11a/g (Wireless LAN),
Resolution	B/W: 600 dpi Full color: 300 dpi - 600 dpi
Variable range of scan resolution	Setting range: 100 dpi - 600 dpi

*¹ Scanning speeds vary according to machine operating conditions, computer (specifications, network traffic, software, etc.), and original types.

1.1.4 FAX**General**

Type:	Desktop type transceiver
Circuit:	PSTN PBX
Connection:	Direct couple
Original Size:	Book (Face down): Maximum Width: 216 mm [8.5 inch] ARDF (Face up): (Single-sided document) Length: 139 - 1200 mm [5.5 - 47.2 inch] Width: 139 - 216 mm [5.5 - 8.5 inch] (Double-sided document) Length: 160 - 356 mm [6.3 - 14.0 inch] Width: 139 - 216 mm [5.5 - 8.5 inch]
Scanning Method:	Flat bed, with CCD
Resolution:	G3 8 x 3.85 lines/mm (Standard) 8 x 7.7 lines/mm (Detail) 8 x 15.4 line/mm (Fine) 200 x 100 dpi (Standard) 200 x 200 dpi (Detail)
Transmission Time:	G3: 3 at 28.8Kbps; Measured with G3 ECM using memory for an ITU-T #1 test document (Slerexe letter) at standard resolution
Data Compression:	MH, MR, MMR, JBIG
Protocol:	Group 3 with ECM
Modulation:	V.34, V.33, V.17 (TCM), V.29 (QAM), V.27ter (G3), V.8, V.21 (G3)

Data Rate:	G3: 33600/31200/28800/26400/24000/21600/ 19200/16800/14400/12000/9600/7200/4800/2400 bps Automatic fallback
I/O Rate:	With ECM: 0 ms/line Without ECM: 2.5, 5, 10, 20, or 40 ms/line
Memory Capacity:	ECM: 128 KB SAF Standard: 4 MB Page Memory: Standard: 4 MB (Print: 2 MB + Scanner: 2 MB)

IFAX Specifications

Connectivity:	Local area network Ethernet 100base-Tx/10base-T IEEE1394 (IP over 1394) IEEE802.11b (wireless LAN)
Resolution:	Main scan: 400 dpi, 200 dpi Sub scan: 400 dpi, 200 dpi, 100 dpi To use 400 dpi, IFAX SW01 Bit 4 must be set to "1".
Transmission Time:	1 s (through a LAN to the server) Condition: ITU-T #1 test document (Selerexe Letter) MTF correction: OFF TTI: None Resolution: 200 x 100 dpi Communication speed: 10 Mbps Correspondent device: E-mail server Line conditions: No terminal access
Document Size:	Maximum message width is A4/LT.  Note <ul style="list-style-type: none"> ▪ To use B4 and A3 width, IFAX SW00 Bit 1 (B4) and/or Bit 2 (A3) must be set to "1".
E-mail File Format:	Single/multi-part MIME conversion Image: TIFF-F (MH, MR, MMR)
Protocol:	Transmission: SMTP, TCP/IP Reception: POP3, SMTP, IMAP4, TCP/IP
Data Rate:	100 Mbps(100base-Tx) 10 Mbps (10base-T)

Authentication Method:	SMTP-AUTH POP before SMTP A-POP
Remark:	The machine must be set up as an e-mail client before installation. Any client PCs connected to the machine through a LAN must also be e-mail clients, or some features will not work (e.g. Autorouting).

IP-FAX Specifications

Network:	Local Area Network Ethernet/10base-T, 100base-TX IEEE1394 (IP over 1394) IEEE802.11b (wireless LAN)
Scan line density:	8 x 3.85 lines/mm, 200 x 100dpi (standard characters) 8 x 7.7lines/mm, 200 x 200dpi (detailed characters)
Original size:	Maximum A3 or 11"x 17" (DLT)
Maximum scanning size:	Standard: A3, 297mm x 432mm Irregular: 297mm x 1200mm
Transmission protocol:	Recommended: T.38 Annex protocol, TCP, UDP/IP communication
Compatible machines:	IP-Fax compatible machines
IP-Fax transmission function:	Specify IP address and send fax to an IP-Fax compatible fax through a network. Also capable of sending fax from a G3 fax connected to the public telephone lines via a VoIP gateway.
IP-Fax reception function:	Receive a fax sent from an IP-Fax compatible fax through a network. Also capable of receiving fax from a G3 fax connected the public telephone lines via a VoIP gateway.

Fax Unit Configuration

Component	Code	No.	Remarks
FCU	-	-	Standard for D115/D116
MBU		-	
Speaker		-	
Handset Type 1018	B433	-	NA only. Common with PG-C1

1.1.5 ARDF

Original Size:	Standard:	A4 to A5; 8 ¹ / ₂ " x 14" to 8 ¹ / ₂ " x 5 ¹ / ₂ "
	Custom (Simplex):	Width: 139 mm to 216 mm Length: 139 mm to 1260 mm
	Custom (Duplex):	Width: 139 mm to 216 mm Length: 160 mm to 356* ¹ mm
	* ¹ : When you use 310 mm or more originals, originals weighing 55k (17 lb. / 64 g/m ²) or less cannot be used in duplex scanning mode.	
Original Weight:	52–105 g/m ² (14–28 lb.)	
Table Capacity:	50 sheets (80 g/m ² , 21 lb.)	
Original Standard Position:	Center	
Separation:	FRR	
Transport:	Roller transport	
Feed Order:	Top first	
Reproduction Range:	50–200%	
Power Source:	24 and 5 Vdc from the copier	
Power Consumption:	Operating: 50 W or less On standby: 1.2 W or less	
Dimensions (W x D x H):	485 x 360 x 120 mm (19.1" x 14.2" x 4.72")	
Weight:	4.9 kg (10.8 lb) (excluding the original table and platen cover)	

1.1.6 PAPER TRAY UNIT

Paper Sizes:	A4 SEF, 8½" x 11" SEF, 8½" x 13" SEF, 8½" x 14" SEF
Paper Weight:	60 – 90 g/m ² , 16 – 24 lb.
Tray Capacity:	500 sheets (80 g/m ² , 21 lb.) x 1 tray
Paper Feed System:	Feed roller and friction pad
Power Source:	24 Vdc and 5 Vdc, from copier. If optional tray heater is installed, the copier also supplies Vac (120 Vac or 220 – 240 Vac).
Power Consumption:	Maximum: 15 W (excluding optional tray heater)
Average:	14 W (excluding optional tray heater)
Weight:	Not above 6 kg (13.2. lb.)
Size (W x D x H):	430 x 414 x 140 mm (16.9" x 16.3" x 5.5")

 Note

- Two can be installed.

1.2 SUPPORTED PAPER SIZES

1.2.1 ORIGINAL PAPER SIZES

The copier and ARDF do not detect original paper sizes. The following table lists the paper sizes that the ARDF can transport.

Paper	Size (W x L)	Book	ARDF	
			Simpl.	Dupl.
A3 SEF	297 x 420 mm	–	–	–
B4 SEF	257 x 364 mm	–	–	–
A4 SEF	210 x 297 mm	X	X	X
A4 LEF	297 x 210 mm	–		
B5 SEF	182 x 257 mm	X	X	X
B5 LEF	257 x 182 mm	–		
A5 SEF	148 x 210 mm	X	X	X
A5 LEF	210 x 148 mm	X	X	
B6 SEF	128 x 182 mm	–		
B6 LEF	182 x 128 mm	–		
A6 SEF	105 x 148 mm	–		
8K SEF	267 x 390 mm	–		
16K SEF	195 x 267 mm	X	X	X
16K LEF	267 x 195 mm	–		
DLT SEF	11.0" x 17.0"	–		
LG SEF	8.5" x 14.0"	X ^{*1}	X	X ^{*2}
LT SEF	8.5" x 11.0"	X	X	X

Paper	Size (W x L)	Book	ARDF	
			Simpl.	Dupl.
LT LEF	11.0" x 8.5"	–		
Executive SEF	7.25" x 10.5"	–	X	X
HLT SEF	5.5" x 8.5"	X	X	X
HLT LEF	8.5" x 5.5"	X	X	
F/GL (F4) SEF	8.0" x 13.0"	X* ¹	X	X* ²
Foolscap SEF	8.5" x 13.0"	X* ¹	X	X* ²
Folio SEF	8.25" x 13.0"	X* ¹	X	X* ²
Government	8.25" x 14"	X* ¹	X	X* ²
USB4 SEF	10.0" x 14.0"	–		
Eng Quarto SEF	8.0" x 10.0"	–	X	X* ²
Eng Quarto LEF	10.0" x 8.0"	–		
Custom:	Width 139-216 mm Length 139-356 mm	–	X* ³	X* ^{2, 4}

Symbol meanings:

X: Can use

–: Cannot use

*1: Can be used when the ARDF is installed

*2: 55k (17 lb./ 64 g/m²) or less original cannot be used.

*3: Width: 139-216 mm, Length: 139-1260 mm

*4: Width 139-216 mm, Length: 160-356 mm

1.2.2 PAPER FEED

The copier and optional paper feed unit do not detect paper sizes. The following table lists the paper sizes that the copier and optional paper feed unit can transport.

Paper	Size (W x L)	Regular	By-pass	Duplex	Optional PFU
A3 SEF	297 x 420 mm	–	–	–	–
B4 SEF	257 x 364 mm	–	–	–	–
A4 SEF	210 x 297 mm	X	X	X	X
A4 LEF	297 x 210 mm	–	–	–	–
B5 SEF	182 x 257 mm	X	X	X	–
B5 LEF	257 x 182 mm	–	–	–	–
A5 SEF	148 x 210 mm	–	X	–	–
A5 LEF	210 x 148 mm	X	X	–	–
B6 SEF	128 x 182 mm	–	–	–	–
B6 LEF	182 x 128 mm	–	–	–	–
A6 SEF	105 x 148 mm	–	–	–	–
8K SEF	267 x 390 mm	–	–	–	–
16K SEF	195 x 267 mm	X	X	X	–
16K LEF	267 x 195 mm	–	–	–	–
DLT SEF	11.0" x 17.0"	–	–	–	–
LG SEF	8.5" x 14.0"	–	X	X	X
LT SEF	8.5" x 11.0"	X	X	X	X
LT LEF	11.0" x 8.5"	–	–	–	–
Executive SEF	7.25" x 10.5"	–	X	–	–
HLT SEF	5.5" x 8.5"	–	X	–	–

Paper	Size (W x L)	Regular	By-pass	Duplex	Optional PFU
HLT LEF	8.5" x 5.5"	X	X	–	–
F/GL (F4) SEF	8.0" x 13.0"	–	X	–	–
Foolscap SEF	8.5" x 13.0"	–	X	X	X
Folio SEF	8.25" x 13.0"	–	X	X	X
Government	8.25" x 14"	–	X	X	X
Com 10 SEF	4.124" x 9.5"	–	X	–	–
Monarch SEF	3.875" x 7.5"	–	X	–	–
C5	162 x 229 mm	–	X	–	–
C6	114 x 162 mm	–	X	–	–
DL Env	110 x 220 mm	–	X	–	–
Custom: Leading edge 90–216 mm Side edge 139–356 mm		–	X	–	–

Symbol meanings:

X: Can transport

–: Cannot transport

APPENDIX:

PREVENTIVE MAINTENANCE

REVISION HISTORY		
Page	Date	Added/Updated/New
		None

2. APPENDIX: PREVENTIVE MAINTENANCE TABLES

2.1 MAINTENANCE TABLES

Reset the PM counter (SP7-804-001) after doing maintenance work.

Key: AN: As necessary, C: Clean, R: Replace, I: Inspect

	Every 45k	Every 90k	AN	NOTE
OPTICS				
Reflector	C		C	Optics cloth
1st mirror	C		C	Optics cloth
2nd mirror	C		C	Optics cloth
3rd mirror	C		C	Optics cloth
Platen cover	C		C	Dry cloth
Exposure glass	C		C	Dry cloth
Toner shield glass	C		C	Dry cloth
DRUM AREA				
PCU	R			Clean toner-bottle holder.
Transfer roller		R		
Discharge plate		R		
PAPER FEED				
Paper feed roller		R	C	Water or alcohol.
Friction pad		R	C	Dry cloth
Bottom-plate pad	C		C	Water or alcohol.
Registration roller	C		C	Water or alcohol.

Maintenance Tables

	Every 45k	Every 90k	AN	NOTE
FUSING UNIT				
Hot roller		R		
Pressure roller		R		
Hot roller bearings		R		
Pressure-roller bushings		I		
Inlet guide		C		
Outlet guide		C		
Hot roller stripper pawls		R		
Thermistor		C		

	Every 90k	AN	NOTE
ARDF			
Separation roller	R	C	Water or alcohol
Pick-up roller	R	C	Water or alcohol
Feed roller	R	C	Water or alcohol
White plate		C	Water or alcohol
DF exposure glass		C	Water
Rollers R0, R1, R2		C	Water or alcohol
Registration sensor reflector		C	Water or alcohol

	Every 120k	AN	NOTE
PAPER TRAY UNIT			
Paper feed roller	R		
Bottom-plate pad		C	Dry cloth
Friction pad	R		

Appendix:
Preventive
Maintenance
Tables

APPENDIX:

SP MODE TABLES

REVISION HISTORY		
Page	Date	Added/Updated/New
124 ~ 125	4/28/2011	Printer SP Mode 1001-006 bit switch 6

3. APPENDIX: SP MODE TABLES

3.1 SYSTEM SERVICE MODE

3.1.1 SERVICE MODE TABLES

SP1-XXX (Feed)

1001*	LE Registration	[-9.0 to 9.0 / 0.0 / 0.1 mm/step]
1001 1	All Trays	Adjusts the leading-edge registration (▶"Adjusting Copy Image Area" in the section "Replacement and Adjustment").
1001 2	By-pass	
1001 3	Duplex	

1002*	S-to-S Regist	[-9.0 to 9.0 / 0.0 / 0.1 mm/step]
1002 1	1st Tray	Adjusts the side-to-side registration (▶"Adjusting Copy Image Area" in the section "Replacement and Adjustment"). SP1-002-001 is applied to all trays. SP1-002-002, 003 and 005 adjusts the difference from SP1-002-001.
1002 2	2nd Tray	
1002 3	3rd Tray	
1002 5	By-pass	
1002 6	Duplex	Adjusts the side-to-side registration of the 2nd side in duplex copying. The 1st side is adjusted by SP1-002-001 through 005.

1003*	Paper Feed Timing	Adjusts the amount of paper buckle on the registration roller.
1003 1	1st tray	[0 to 10 / 5 / 1 mm/step]
1003 3	Bank Trays	[0 to 10 / 5 / 1 mm/step]
1003 4	By-pass	[0 to 10 / 5 / 1 mm/step]
1003 5	Duplex	[0 to 20 / 5 / 1 mm/step]

1103*	Fusing Idling	[0 = No / 1 = Yes]	
1103 1	Enables or disables the contact-release control. The following table lists the results.		
	Setting	0 = No	1 = Yes
	C-R control	Works	Does not work
	Idling time	Shorter	Longer
	Fusing quality	Lower	Higher

1105*	Fusing Temp Adj	
	Adjusts the target fusing temperature. Note that the thermistor is at the center of the hot roller.	
1105 1	Warm Up-Center	[140 to 180 / 160 / 1°C/step]
1105 3	Standby-Center	[140 to 160 / 150 / 1°C/step]
1105 5	Copying-Center	[140 to 180 / 160 / 1°C/step]
1105 7	Low Level 2-Center	[0 to 80 / 60 / 1°C/step]
1105 9	Thick-Center	[140 to 185 / 165 / 1°C/step]

1106	Display Fusing
1106 1	(Center) Displays the fusing temperature.

1107*	Fusing Soft Start DFU	
	Adjusts the number of zero-cross cycles of the fusing lamp AC supply needed to bring the fusing lamp power to 100% while bringing the lamp up to the standby temperature or while copying. Increase this value if the machine is experiencing sudden power dropouts.	
1107 1	Warm Up Soft Start	[0 = 10 times / 1 = 20 times / 2 = 50 times]

1107 2	Other Soft Start	[0 = 10 times / 1 = 20 times / 2 = 50 times / 3 = 1 time]
1107 3	Soft Stop Setting	[0: No / 1: Yes]

1108*	Set-Fusing Start	[0 = 1s / 1 = 1.5s / 2 = 2s]
1108 1	Specifies the interval for fusing-temperature control.	

1109	Nip Band Check	
1109 1	Conducts the nip band check (☞ "Adjusting Nip Band" in the section "Replacement and Adjustment").	

1110*	Fan Control Timer	[30 to 60 / 30 / 1 s/step]
1110 1	Specifies the fan control time. The fan motor keeps its operating speed for the specified time before changing the speed or stopping. The fan control timer prevents the exhaust fan from suddenly stopping. This function protects the copier from overheating.	

1159*	Fusing Jam SC	[0 = No / 1 = Yes]
1159 1	Enables or disables consecutive jam detection at the fusing unit. If this SP is set to "1" (default: 0), consecutive fusing jam alarm occurs (SC559) when the machine detects three consecutive paper jams at the fusing unit.	

1902	Display-AC Freq.	
1902 1	Displays the fusing lamp power control frequency (as detected by the zero cross signal generator). The displayed value is 1/5 the actual frequency: 10 and lower = 50 Hz, 11 and higher = 60 Hz.	

System Service Mode

1911*	By-pass Envelope	[0 = No / 1= Yes]
1911 1	The program dedicated to envelope printing runs when you enable this program (SP1-911-001) and you select "Thick Paper" as the paper type of the by-pass tray ( > System Settings > Tray Paper Settings > Paper Type: Bypass Tray).	

SP2-XXX (Drum)

2001*	CR Bias Adj	
2001 1	Printing	[-2100 to -1500 / -1650 / 1 V/step]
	Adjusts the voltage applied to the charge roller for printing. The voltage changes automatically as charge-roller voltage control works. The value here is the base value for the charge-roller voltage control.	
2001 2	ID sensor pattern	[0 to 400 / 300 / 1 V/step]
	Adjusts the voltage applied to the charge roller for the ID sensor pattern (as part of charge-roller voltage correction). The charge-roller voltage is obtained by adding SP2-001-002 to the value of SP2-001-001.	

2101*	Erase Margin Adj	Adjusts the width of the erased area (☛ "Adjusting Copy Image Area" in the section "Replacement and Adjustment").
2101 1	Leading Edge	[0.0 to 9.0 / 3.0 / 0.1 mm/step] Specification: 2 ± 1.5 mm
2101 2	Trailing Edge	[0.0 to 9.0 / 4.0 / 0.1 mm/step] Specification: 2 +2.5/-1.5 mm
	The rear trailing edge is this value plus 1.2 mm.	
2101 3	Left side	[0.0 to 9.0 / 2.0 / 0.1 mm/step] Specification: 2 ± 1.5 mm
	The rear left edge is this value plus 0.3 mm.	
2101 4	Right side	[0.0 to 9.0 / 2.0 / 0.1 mm/step] Specification: 2 +2.5/-1.5 mm
	The rear right edge is this value plus 0.3 mm.	

2201*	Dv Bias Adj	
2201 1	Printing	[-1500 to -200 / -650 / 1 V/step]
	Adjusts the voltage applied to the development roller for printing. Image density becomes higher when you specify a smaller value (a greater absolute value). Image density becomes lower when you specify a greater value (a smaller absolute value).	
2201 2	ID sensor pattern	[-2 = LL (220 V) / -1 = L (260 V) / 0 = N (300 V) / 1 = H (340 V) / 2 = HH (380 V)]
	Adjusts the voltage applied to the development roller for the ID sensor pattern. The voltage applied is obtained by adding SP2-201-002 to SP2-201-1. The setting affects ID sensor pattern density, which in turn affects the toner supply.	

2213*	Outputs After NE	
2213 1	[0 = 50 pages / 1 = 20 sheets] Sets the number of copy/print/fax pages that can be made after toner near-end has been detected. Reduce the number of pages if the user normally makes copies with a high image ratio.	

2214	Develpr Initialize	
2214 1	Initializes the TD sensor toner supply target voltage and the TD sensor gain value. Execute this SP replacing the developer or the TD sensor.	

2221	ID Error Analysis ( "ID Sensor Error Analysis (SP2-221)")	
2221 1	Vsg	Displays the Vsg value.
2221 2	Vsp	Displays the Vsp value.
2221 3	PWM	Displays the PWM value.
2221 4	Vsdp	Displays the Vsdp value.

2221 5	Vt	Displays the Vt value.
2221 6	Vts	Displays the Vts value.

2301*	Tr Current Adj (🖨️ "Image Transfer Current").	
2301 1	Normal paper	[-2 = -4 μ A / -1 = -2 μ A / 0 = 0 μ A / 1 = 2 μ A / 2 = +4 μ A]
	Adjusts the current applied to the transfer roller when feeding from a paper tray. Use a high setting if the user normally feeds relatively thick paper (within spec) from a paper tray	
2301 2	Thick/Special	[-2 = -4 μ A / -1 = -2 μ A / 0 = 0 μ A / 1 = 2 μ A / 2 = +4 μ A]
	Adjusts the current applied to the transfer roller when feeding from the by-pass tray. Use a high setting (a) if the user normally feeds relatively thick paper from the by-pass tray, or (b) if waste toner is re-attracted from the drum (which can occur when using transparencies).	
2301 3	Duplex	[-2 = -4 μ A / -1 = -2 μ A / 0 = 0 μ A / 1 = 2 μ A / 2 = +4 μ A]
	Adjusts the current applied to the transfer roller when carrying out a duplex job. Use this SP if there is poor image transfer on the rear side of duplex copies.	
2301 4	Cleaning	[-10 to 1 / -1 / 1 μ A/step]
	Adjusts the current applied to the transfer roller for roller cleaning. Increase the current if toner remains on the roller after cleaning. (Remaining toner may cause dirty background on the rear side.)	

2802	Forced Develop Churn	
2802 1	Initializes the developer and checks the TD sensor output (Vt). The machine mixes the developer for 2 minutes while reading and displaying the Vt value. The machine does not initialize the TD sensor output. If the machine has not been used for a long period, prints may have a dirty background. In a case	

	like this, use this SP to mix the developer. The message "Completed" is displayed when the program ends normally.
--	---

2906*	Tailing Crctn	
2906 1	Shift value	[0.0 to 1.0 / 0.0 / 0.1 mm/step]
	Shifts the image position at the intervals specified by SP2-906-002. When the copier is continuously printing vertical lines (such as in tables), the paper may not separate correctly. This SP can prevent this.	
2906 2	Interval	[1 to 10 / 1 / 1 page/step]
	Changes the interval of the image position shift specified by SP2-906-001.	

2908	Forced Toner Supp	
2908 1	Supplies the toner to the development unit. The processing stops under either of the following conditions: <ul style="list-style-type: none"> ▪ The toner density in the development unit reaches the standard level. ▪ The processing has continued for two 2 minutes. 	

2915*	Polygon Idling	[0 = None / 1 = 15 s / 2 = 25 s]
2915 1	Specifies the polygon mirror motor idling time. The polygon mirror motor starts its operation when an original is set, a key is pressed, or the platen cover or DF is opened. The motor stops if no manual operation is performed for the specified time. When you set "0", the motor does not stop while the copier is in the standby status.	

2921*	Toner Supply Mode	
2921 1	[0 = Sensor 1 / 1 = Sensor 2 (DFU)] Selects the toner supply mode. Keep the default setting as long as the TD sensor is working.	

2922*	Toner Supply Time	[0.1 to 5.0 / 0.6 / 0.1 s/step]
2922 1	Adjusts the toner supply time. The toner supply motor remains on for the specified time. To validate this setting, select "0" in SP2-921-001. Specify a greater value if the user tends to make many copies having high proportions of solid black image areas.	

2926*	Standard Vt	[0.00 to 5.00 / 2.50 / 0.01 V/step] DFU
2926 1	Adjusts Vts (the Vt value for new developer). The TD sensor output is adjusted to this value during the TD sensor initial setting process. This SP is effective only when SP2-921001 is "0", "1", or "2".	

2927*	ID Sensor Control	[0 = No / 1 = Yes]
2927 1	Determines whether the ID sensor signal is referenced or not for the toner density control. Keep the default value in usual operations.	

2928	Toner End Clear	
2928 1	<p>Clears the following messages and counters without supplying the toner:</p> <ul style="list-style-type: none"> ▪ Toner near end message ▪ Toner end message ▪ Toner near end counter ▪ Toner end counter <p>Do not use this SP in usual operations. When the toner in the development unit is abnormally insufficient, the drum may attract the toner carrier to its surface. The toner carrier damages the drum surface..</p>	

2929*	Vref Limits	Adjust the upper or lower Vref limit.
2929 1	Upper	[0.50 to 3.50 / 3.20 / 0.01V/step] DFU
2929 2	Lower	[0.50 to 3.50 / 0.70 / 0.01V/step] DFU

2994*	ID Detect Temp	[30 to 90 / 30 / 1°C/step]
2994 1	Adjusts the temperature threshold. The ID sensor signal is not referenced when the fusing temperature is at the specified level or higher while the copier is recovering or starting up.	

2996*	T Roller Cleaning	[0 = No / 1 = Yes]
2996 1	Cleans or does not clean the transfer roller before each job. Select "1" if the backside of the paper becomes unclean when output. Note that the copier takes a longer time to output the first copy when you select "1". If you select "0", the transfer roller is never cleaned.	

2998*	Main Mag- print	[-0.5 to +0.5 / 0.0 / 0.1%/step]
2998 1	Adjusts the magnification (👉 "Adjusting Copy Image Area" in the section "Replacement and Adjustment"). The specification is 100 ±1.0%.	

SP4-XXX (Scanner)

4008*	SubScan Mag (Scanner)	[-0.9 to +0.9 / 0.0 / 0.1%/step]
4008 1	Adjusts the sub-scan magnification (☞ "Adjusting Copy Image Area" in the section "Replacement and Adjustment").	

4009*	Main Scan Mag (Scanner)	[-0.9 to +0.9 / 0.0 / 0.1%/step]
4009 1	Adjusts the main-scan magnification (☞ "Adjusting Copy Image Area" in the section "Replacement and Adjustment").	

4010*	LE Scan Regist	[-5.0 to +5.0 / 0.0 / 0.1 mm/step]
4010 1	Adjusts the leading edge registration (☞ "Adjusting Copy Image Area" in the section "Replacement and Adjustment").	

4011*	S-to-S Scanner Registration	[-2.0 to +2.0 / 0.0 / 0.1 mm/step]
4011 1	Adjusts the side-to-side registration for scanning in platen mode (☞ "Adjusting Copy Image Area" in the section "Replacement and Adjustment").	

4012*	Scan Erase Margin	[0 to 9.0 / 1.0 / 0.1 mm/step]
4012 1	Leading Edge	Adjusts the scanning margin. Generally, the scanning margin should be as little as possible. To adjust the image area, use SP2-101.
4012 2	Trailing Edge	
4012 3	Left Side	
4012 4	Right Side	

4013	Scanner Free Run	
4013 1	Conducts the scanner free run with the exposure lamp on.	

4015*	White Plate Scan	
4015 1	Start position	[-3.0 to +6.0 / 0.0 / 0.1 mm/step]
	Adjusts the scanning start position on the white plate. The base value is 17.8 mm from the scanner home position. This SP specifies the offset from this base value.	
4015 2	Scanning Length	[-3.0 to +6.0 / 0.0 / 0.1 mm/step]
	Adjusts the distance of the white plate scan. The scan begins from the start position (SP4-015-001) and ends at the specified distance. The base value is 2.0 mm. This SP decides the offset from this base value. Specify 0 (zero) or a larger value.	

4428	Scan Auto Adj	
4428 1	Conducts the automatic scanner adjustment. Use this SP after replacing the white plate (👉 "Scanning" in the section "Replacement and Adjustment").	

4606	SBU Offset-Target	
4607 1	EVEN	[0 to 63 / 10 / 1 /step] Adjusts the target black level for each signal. These are used for offset adjustment in the SBU.
4607 2	ODD	
4607 3	RED	
4607 4	GREEN	
4607 5	BLUE	

4607	SBU Gain-Target	
4607 1	EVEN	<p>[0 to 255 / 180 / 1 /step]</p> <p>Adjusts the target white level for each signal. These are used for gain adjustment in the SBU.</p>
4607 2	ODD	
4607 3	RED	
4607 4	GREEN	
4607 5	BLUE	

4623	SBU Offset-Result	
4623 1	EVEN	<p>[0 to 255 / 0 / 1 /step]</p> <p>Displays the result value of the offset adjustment in the SBU.</p>
4623 2	ODD	
4623 3	RED	
4623 4	GREEN	
4623 5	BLUE	

4628	SBU Gain-Result	
4628 1	EVEN	<p>[0 to 255 / 0 / 1 /step]</p> <p>Displays the result value of the gain adjustment in the SBU.</p>
4628 2	ODD	
4628 3	RED	
4628 4	GREEN	
4628 5	BLUE	

4640	SBU Offset-Loop	
4640 1	EVEN	<p>[0 to 10 / 0 / 1 /step]</p> <p>Displays the number of the offset adjustment in the SBU.</p>
4640 2	ODD	
4640 3	RED	

System Service Mode

4640 4	GREEN	
4640 5	BLUE	

4641	SBU Gain-Loop	
4641 1	EVEN	<p>[0 to 10 / 0 / 1 /step]</p> <p>Displays the number of the gain adjustment in the SBU.</p>
4641 2	ODD	
4641 3	RED	
4641 4	GREEN	
4641 5	BLUE	

4642	SBU Offsetpre-Loop	
4642 1	EVEN	<p>[0 to 3 / 0 / 1 /step]</p> <p>Displays the number of the pre-offset adjustment in the SBU.</p>
4642 2	ODD	
4642 3	RED	
4642 4	GREEN	
4642 5	BLUE	

4646	SBU Adj Error	
4646 1	Offsetpre-Mono	<p>[0 = Success / 1 = Failure]</p> <p>Displays the result of SBU adjustment.</p>
4646 2	Offsetpre-Color	
4646 3	Offset-Mono	
4646 4	Offset-Color	
4646 5	Gain-Mono	
4646 6	Gain-Color	

4654*	SBU Offset-Adjust	
4654 1	EVEN	[0 to 255 / - / 1 /step] Displays the offset value of the offset adjustment in the SBU.
4654 2	ODD	
4654 3	RED	
4654 4	GREEN	
4654 5	BLUE	

4658*	SBU Gain-Adjust	
4658 1	EVEN	[0 to 511 / - / 1 /step] Displays the gain value of the gain adjustment in the SBU.
4658 2	ODD	
4658 3	RED	
4658 4	GREEN	
4658 5	BLUE	

4685*	Gray Balance-Book	
4685 1	RED	[128 to 383 / 256 / 1 /step] Adjusts the coefficient of the gray balance adjustment for the book scanning.
4685 2	GREEN	
4685 3	BLUE	

4686*	Gray Balance-DF	
4686 1	RED	[128 to 383 / 256 / 1 /step] Adjusts the coefficient of the gray balance adjustment for the DF scanning.
4686 2	GREEN	
4686 3	BLUE	

System Service Mode

4687*	White Balance	
4687 1	Adjust	[222 to 281 / 256 / 1 /step] Adjust the correction value for the white plate adjustment.
4687 2	Result	Displays the current value of the white plate adjustment. If SP4-428 has not been done, this value is "0".

4690	White Peek Init	
4658 1	EVEN	[0 to 255 / - / 1 /step] Displays the white offset value of the pre-offset adjustment in the SBU.
4658 2	ODD	
4658 3	RED	
4658 4	GREEN	
4658 5	BLUE	

4693	Black Ave Init	
4658 1	EVEN	[0 to 255 / - / 1 /step] Displays the black offset value of the pre-offset adjustment in the SBU.
4658 2	ODD	
4658 3	RED	
4658 4	GREEN	
4658 5	BLUE	

4902*	Exposure Lamp ON	[0: OFF / 1: ON]
4902 1	Turns the exposure lamp on or off. To turn on the exposure lamp, specify "1"; to turn it off specify "0".	

4903*	ADS Level	[0 to 255 / 252 / 1/step]
4903 1	Adjusts the ADS level.	

4904*	ADS Lower Limit	[0 to 255 / 80 / 1/step]
4904 1	Adjusts the ADS lower limit.	

4905*	ADS Area Select	[0 = All / 1 = One]
4905 1	Checks the whole area (0 = All) or the specific areas (1 = One) to adjust the ADS level. The specific areas are as follows: <ul style="list-style-type: none"> ▪ ARDF: ± 37.5 mm from the center ▪ Platen Cover: 15 to 90 mm from the left edge 	

4921*	Image Adj Selec	
001	Copy	[0 to 10 / 0 / 1]
	Selects which mode the settings from SP4-922 to SP4-932 are used for. 0 = None, 1 = Text 1, 2 = Text 2, 3 = Photo 1, 4 = Photo 2, 5 = Photo 3, 6 = Special 1, 7 = Special 2, 8 = Special 3, 9 = Special 4, 10 = Special 5	
002	Fax	[0 to 5 / 0 / 1]
	Selects which mode the settings from SP4-922 to SP4-932 are used for. 0 = None, 1 = Text 1, 2 = Text 2, 3 = Photo 1, 4 = Photo 2, 5 = Special 1	
003	Scanner (Mono)	[0 to 4 / 0 / 1]
	Selects which mode the settings from SP4-922 to SP4-932 are used for. 0 = None, 1 = Text 1, 2 = Text 2, 3 = Photo 1, 4 = Photo 2	
004	Scanner (Color)	[0 to 2 / 0 / 1]
	Selects which mode the setting of SP4-935 is used for. 0 = None, 1 = Color Text, 2 = Color Photo	

System Service Mode

005	Scanner (Gray Scale)	[0 or 1 / 0 / -]
	Selects which mode the setting of SP4-936 is used for. 0 = None, 1 = Gray Scale	

4922*	Scanner Gamma	
	Selects "text" or "photo" as the priority output mode. This setting is applied to all image processing modes of SP4-921.	
001	Copy	[0=System default/ 1=Text/ 2=Photo]
002	Fax	
003	Scanner	

4923*	Notch Selection	
	Selects the value of the center ID adjustment notch for the ID adjustment LEDs. <ul style="list-style-type: none"> ▪ Normally the center notch is 3 (range 1-5). If -1 is selected, each notch shifts down (becomes lighter). If +1 is selected, each notch shifts up (becomes darker). ▪ This setting is applied to all image processing modes of SP4-921. 	
001	Copy	[-1 = Light / 0 = Normal / +1 = Dark]
002	Fax	
003	Scanner	

4926*	Texture Removal	
	Adjusts the texture removal level that is used with error diffusion. 0: The default value for each mode is used. Text 1, Photo 2, Special 2, and Special 5 have a default of 3 and Photo 1-3 have a default of 1. 1: No removal applied. 2 to 5: Removal applied at the level specified here. The higher the setting (level), the less clear the image will become (more texture removal). This setting is only applied to the originals in SP4-921.	
001	Copy	[0 to 6 / 0 / 1/step]
002	Fax	
003	Scanner	

4927*	Line Width	
	Adjusts the line width correction algorithm. Positive settings produce thicker lines; negative settings produce thinner lines. This setting is only applied to the originals in SP4-921.	
001	Copy	[-2 to 2 / 0 / 1/step]
002	Fax	
003	Scanner	

4928*	Independent Dot Erase	
	Selects the dot erase level. Higher settings provide greater erasure. This setting is only applied to the originals in SP4-921.	
001	Copy	[-2 to 2 / 0 / 1/step]
002	Fax	
003	Scanner	

4929*	Positive/Negative	[0 = No, 1 = Yes]
	Inverts white and black. This setting is only applied to the originals in SP4-921.	
001	Copy	
002	Fax	

4930*	Sharpness-Edge	[-2 to 2 / 0 / 1/step]
	Adjust the clarity. This setting is only applied to the originals in SP4-921.	
001	Copy	
002	Fax	
003	Scanner	

4931*	Sharpness-Solid	[-2 to 2 / 0 / 1/step]
	Adjust the clarity. This setting is only applied to the originals in SP4-921.	
001	Copy	
002	Fax	
003	Scanner	

4932*	Sharpness-Low ID	[-2 to 2 / 0 / 1/step]
	Adjust the clarity. This setting is only applied to the originals in SP4-921.	
001	Copy	
002	Fax	
003	Scanner	

4935*	Color Image Adjust	
001	Main Scan MTF Level	[0 to 3 / 0 / 1/step]
	Adjust the MTF level for the main scan. This setting is only activated for the specified mode with SP4-921-004. 0: None, 1: Weak, 2: Middle, 3: Strong	
002	Main Scan MTF Strength	[0 to 5 / 0 / 1/step]
	Adjust the MTF strength for the main scan. This setting is only activated for the specified mode with SP4-921-004. 0: 1, 1: 1/32, 2: 1/16, 3: 1/8, 4: 1/4, 5: 1/2	
003	Sub Scan MTF Level	[0 or 1 / 0 / 1/step]
	Turns on or off the MTF for the sub scan. This setting is only activated for the specified mode with SP4-921-004. 0: No, 1: Yes	
004	Sub Scan MTF Strength	[0 to 5 / 0 / 1/step]
	Adjust the MTF strength for the sub scan. This setting is only activated for the specified mode with SP4-921-004. 0: 1, 1: 1/32, 2: 1/16, 3: 1/8, 4: 1/4, 5: 1/2	
005	Smooth Level	[0 to 2 / 0 / 1/step]
	Adjust the smooth level. This setting is only activated for the specified mode with SP4-921-004. 0: None, 1: Weak, 2: Strong	
006	Brightness	[0 to 255 / 128 / 1/step]
	Adjust the brightness level. This setting is only activated for the specified mode with SP4-921-004.	
007	Contrast	[0 to 255 / 128 / 1/step]
	Adjust the contrast level. This setting is only activated for the specified mode with SP4-921-004.	

4936*	Gray Scale Image Adjust	
001	Main Scan MTF Level	[0 to 15 / 0 / 1/step]
	Adjust the MTF level for the main scan. This setting is only activated for the specified mode with SP4-921-004. 0: None, 1: Level 1 to 15: Level 15	
002	Main Scan MTF Strength	[0 to 5 / 0 / 1/step]
	Adjust the MTF strength for the main scan. This setting is only activated for the specified mode with SP4-921-004. 0: 1, 1: 1/32, 2: 1/16, 3: 1/8, 4: 1/4, 5: 1/2	
003	Sub Scan MTF Level	[0 to 13 / 0 / 1/step]
	Adjust the MTF level for the sub scan. This setting is only activated for the specified mode with SP4-921-004. 0: No, 1: Level 1 to 13: Level 13	
004	Sub Scan MTF Strength	[0 to 5 / 0 / 1/step]
	Adjust the MTF strength for the sub scan. This setting is only activated for the specified mode with SP4-921-004. 0: 1, 1: 1/32, 2: 1/16, 3: 1/8, 4: 1/4, 5: 1/2	
005	Smooth Level	[0 to 7 / 0 / 1/step]
	Adjust the smooth level. This setting is only activated for the specified mode with SP4-921-004. 0: None, 1: Level 1 to 7: Level 7	
006	Brightness	[0 to 255 / 128 / 1/step]
	Adjust the brightness level. This setting is only activated for the specified mode with SP4-921-004.	
007	Contrast	[0 to 255 / 128 / 1/step]
	Adjust the contrast level. This setting is only activated for the specified mode with SP4-921-004.	

4941*	White Line Erase	[0 to 2 / 1 / 1/step]
4941 1	<p>Selects the white line erase level.</p> <p>0: None, 1: Weak, 2: Strong</p> <ul style="list-style-type: none"> ▪ This setting is effective for all modes. ▪ 0: White line erase is not used, and white level correction is used instead. ▪ This setting is applied regardless of what mode has been selected in SP4-921. 	

4942*	Black Line Erase	[0 to 3 / 2 / 1/step]
4942 1	<p>Selects the black line erase level. This setting is effective only when originals are scanned by the DF.</p> <p>[0 = No / 1 = Very weak / 2 = Weak / 3 = Strong]</p> <p>This setting is applied regardless of what mode has been selected in SP4-921.</p>	
4943*	WhitePapDetect BiLv	
4943 1	Gray Scale	[0 to 255 / 64 / 1/step]
4943 1	Color2	[0 to 255 / 128 / 1/step]
4943 1	Color3	[0 to 255 / 128 / 1/step]

SP5-XXX (Mode)

5001	All Indicators On
5001 1	Turns on all LEDs. The LCDs turn on and off every 3 seconds. Press the reset key to end this program.

5024*	mm/inch Selection
001	<p>Selects whether mm or inches are used in the display.</p> <p> Note</p> <ul style="list-style-type: none"> After selecting the number, you must turn the main power switch off and on. <p>Europe/Asia model: [0: mm / 1: inch] American model: [0: mm / 1: inch]</p>

5045*	According Counter		
5045 1	<table border="1"> <tr> <td>Counter Method</td> <td> Displays the number of the installed counter. [0 to 2 / 0 / 1 /step] 0: 1 counter (Total) 1: 2 counters (Total and Prints) 2: 2 counters GPC </td> </tr> </table>	Counter Method	Displays the number of the installed counter. [0 to 2 / 0 / 1 /step] 0: 1 counter (Total) 1: 2 counters (Total and Prints) 2: 2 counters GPC
Counter Method	Displays the number of the installed counter. [0 to 2 / 0 / 1 /step] 0: 1 counter (Total) 1: 2 counters (Total and Prints) 2: 2 counters GPC		

5055	Display IP address			
001	<table border="1"> <tr> <td>Display IP address</td> <td>CTL</td> <td> Displays or does not display the IP address on the LCD. [0 or 1 / 0 / -] 0: No (Not display), 1: Yes (Display) </td> </tr> </table>	Display IP address	CTL	Displays or does not display the IP address on the LCD. [0 or 1 / 0 / -] 0: No (Not display), 1: Yes (Display)
Display IP address	CTL	Displays or does not display the IP address on the LCD. [0 or 1 / 0 / -] 0: No (Not display), 1: Yes (Display)		

5056	Coverage Counter		
001	Coverage Counter	CTL	Displays or does not display the coverage counter on the LCD. [0 or 1 / 0 / -] 0: Not display, 1: Display

5062	Part Replacement		
001	PCU	CTL	Displays or does not display the PCU yield on the LCD. [0 or 1 / 0 / -] 0: Not display, 1: Display

5066	PM Parts Display		
001	PM Parts Display	CTL	Displays or does not display the PM part button on the LCD. [0 or 1 / 0 / -] 0: Not display, 1: Display

5067	Part Replacement Ope		
001	PCU	CTL	Selects the service maintenance or user maintenance for PCU. [0 or 1 / 0 / -] 0: Service , 1: User

5113	Optional Counter Type		
001	Opt Cnt Type 1	CTL	This program specifies the counter type. 0: None 1: Key card (RK 3, 4) 2: Key card (down) 3 to 10: (Japan only) 11: Exp. Key card (Add)

			12: Exp. Key card (Deduct)
002	Opt Cnt Type 2	CTL	This program specifies the external counter type. 0: None 1: Expansion Device type 1 2: Expansion Device type 2 3: Expansion Device type 3

5114	Optional Counter I/F	CTL	[0: Not installed/ 1: Installed (scanning accounting)]
001	MF Key Card Ext. Japan use		

5118	Disable Copying	CTL	[0: Not disabled/ 1: Disabled]
001	This program disables copying.		

5120*	Clr For Cut Remove	[0=Yes / 1=Standby only / 2=No]
5120 1	<p>Specifies the condition to reset the copy job settings when the key counter is removed.</p> <ul style="list-style-type: none"> ▪ 0: Y = Yes: The settings are cleared when the counter is removed. ▪ 1: StdBy = Standby only: The settings are cleared when the counter is removed at the end of a job. ▪ 2: N = No: The settings are not cleared under either condition. <p>As for duplex copying, the job settings are always preserved regardless of these setting.</p>	

5121*	Counter Up Timing	[0 = Feed In / 1 = Exit]
5121 1	<p>Selects the count-up timing.</p> <ul style="list-style-type: none"> ▪ 0 = Feed: At each paper feed ▪ 1= Exit: At each paper exit 	

5167	Fax Prnt Cnt Off		
	Enables or disables the automatic print out without an accounting device. This SP is used when the receiving fax is accounted by an external accounting device.		
001	Fax Prnt Cnt Off	CTL	[0 or 1 / 0 / -] 0: Automatic printing 1: No automatic printing

5169	CE Login		
	If you change the printer bit switches, you must 'log in' to service mode with this SP before you go into the printer SP mode.		
001	CE Login	CTL	[0 or 1 / 0 / -] 0: Disabled 1: Enabled

5188	Copy NV Version		
001	Copy NV Version	CTL	Displays the NVRAM version in the controller board.

5302	Set Time		
	Adjusts the RTC (real time clock) time setting for the local time zone. Examples: For Japan (+9 GMT), enter 540 (9 hours x 60 min.) DOM: +540 (Tokyo) NA :-300 (New York) EU :+ 60 (Paris) CH :+480 (Peking) TW :+480 (Taipei) AS :+480 (Hong Kong)		
002	Time Difference	CTL #	[-1440 to 1440 / Area / 1 min./step]

5307	Summer Time		
001	ON/OFF	-	[0 or 1 / NA, EU, ASIA / 1 /step] 0: Disabled 1: Enabled NA and EUR: 1, ASIA: 0
	Enables or disables the summer time mode.  Note <ul style="list-style-type: none"> Make sure that both SP5-307-3 and -4 are correctly set. Otherwise, this SP is not activated even if this SP is set to "1". 		
003	Start	-	-
	Specifies the start setting for the summer time mode. There are 8 digits in this SP. For months 1 to 9, the "0" cannot be input in the first digit, so the eight-digit setting for -2 or -3 becomes a seven-digit setting. 1st and 2nd digits: The month. [1 to 12] 3rd digit: The week of the month. [1 to 5] 4th digit: The day of the week. [0 to 6 = Sunday to Saturday] 5th and 6th digits: The hour. [00 to 23] 7th digit: The length of the advanced time. [0 to 9 / 1 hour /step] 8th digit: The length of the advanced time. [0 to 5 / 10 minutes /step] For example: 3500010 (EU default) The timer is advanced by 1 hour at am 0:00 on the 5th Sunday in March <ul style="list-style-type: none"> The digits are counted from the left. Make sure that SP5-307-1 is set to "1". 		
004	End	-	-
	Specifies the end setting for the summer time mode. There are 8 digits in this SP. 1st and 2nd digits: The month. [1 to 12] 3rd digit: The week of the month. [0 to 5] 4th digit: The day of the week. [0 to 6 = Sunday to Saturday] 5th and 6th digits: The hour. [00 to 23] The 7th and 8th digits must be set to "00". <ul style="list-style-type: none"> The digits are counted from the left. Make sure that SP5-307-1 is set to "1". 		

5401	Access Control		
	When installing the SDK application, SAS (VAS) adjusts the following settings. DFU		
103	DocAcl	CTL	
104	Authentication Time	CTL	[0 to 255 / 0 / 1 /step]
162	Extend Certification	CTL	Selects the log out type for the extend authentication device. Bit 0: Log-out without an IC card. 0: Not allowed (default) 1: Allowed
200	SDK1 Unique ID	CTL	"SDK" is the "software development kit". This data can be converted from SAS (VAS) when installed or uninstalled. (DFU)
201	SDK1 Certification Method	CTL	
210	SDK2 Unique ID	CTL	
211	SDK2 Certification Method	CTL	
220	SDK3 Unique ID	CTL	
221	SDK3 Certification Method	CTL	
230	SDK Cert	CTL	
240	Detail Option	CTL	

5404	User Code Clear
001	Clears the counts for the user codes assigned by the key operator to restrict the use of the machine. Press [Execute] to clear.

5411	LDAP Certification
	Easy Certification
004	Determines whether easy LDAP certification is done. [0 to 1/1/1] 1: On 0: Off
	Password Null Not Permit
005	This SP is referenced only when SP5411-4 is set to "1" (On). [0 to 1/0/1] 0: Password NULL not permitted. 1: Password NULL permitted.

5413	Lockout Setting
	Lockout On/Off
001	Switches on/off the lock on the local address book account. [0 to 1/0/1] 0: Off 1: On
	Lockout Threshold
002	Sets a limit on the frequency of lockouts for account lockouts. [1 to 10/5/1]

003	Cancel On/Off
	<p>Determines whether the system waits the prescribed time for input of a correct user ID and password after an account lockout has occurred.</p> <p>[0 to 1/0/1]</p> <p>0: Off (no wait time, lockout not cancelled)</p> <p>1: On (system waits, cancels lockout if correct user ID and password are entered).</p>
004	Cancel Time
	<p>Determines the length of time that the system waits for correct input of the user ID and password after a lockout has occurred. This setting is used only if SP5413-3 is set to "1" (on).</p> <p>[1 to 999/60/1 min.]</p>

5414	Access Mitigation
001	Mitigation On/Off
	<p>Switches on/off masking of continuously used IDs and passwords that are identical.</p> <p>[0 to 1/0/1]</p> <p>0: Off</p> <p>1: On</p>
002	Mitigation Time
	<p>Sets the length of time for excluding continuous access for identical user IDs and passwords.</p> <p>[0 to 60/15/1 min.]</p>

Appendix:
SP Mode
Tables

5415	Password Attack
001	Permissible Number
	Sets the number of attempts to attack the system with random passwords to gain illegal access to the system. [0 to 100/ 30 /1 attempt]
002	Detect Time
	Sets the time limit to stop a password attack once such an attack has been detected. [1 to 10/ 5 /1 sec.]

5416	Access Info
001	User Max Num
	Limits the number of users used by the access exclusion and password attack detection functions. [50 to 200/ 200 /1 users]
002	Password Max Num
	Limits the number of passwords used by the access exclusion and password attack detection functions. [50 to 200/ 200 /1 passwords]
003	Monitor Interval
	Sets the processing time interval for referencing user ID and password information. [1 to 10/ 3 /1 sec.]

5417	Access Attack
001	Permissible Num
	Sets a limit on access attempts when an excessive number of attempts are detected for MFP features. [0 to 500/ 100 /1]
002	Attack Detect Time
	Sets the length of time for monitoring the frequency of access to MFP features. [10 to 30/ 10 /1 sec.]
003	Cert Waite
	Sets the wait time to slow down the speed of certification when an excessive number of access attempts have been detected. [0 to 9/ 3 /1 sec.]
004	Attack Max Num
	Sets a limit on the number of requests received for certification in order to slow down the certification speed when an excessive number of access attempts have been detected. [50 to 200/ 200 /1 attempt]

5420	User Auth
	<p>These settings should be done with the System Administrator.</p> <p>Note: These functions are enabled only after the user access feature has been enabled.</p>
001	<p>Copy</p> <p>Determines whether certification is required before a user can use the copy applications.</p> <p>[0 to 1/0/1]</p> <p>0: On</p> <p>1: Off</p>
011	<p>DS</p> <p>Determines whether certification is required before a user can use the document server.</p> <p>[0 to 1/0/1]</p> <p>0: On</p> <p>1: Off</p>
021	<p>Fax</p> <p>Determines whether certification is required before a user can use the fax application.</p> <p>[0 to 1/0/1]</p> <p>0: On</p> <p>1: Off</p>
031	<p>Scanner</p> <p>Determines whether certification is required before a user can use the scan applications.</p> <p>[0 to 1/0/1]</p> <p>0: On</p> <p>1: Off</p>

041	Printer	
	Determines whether certification is required before a user can use the printer applications. [0 to 1/0/1] 0: On 1: Off	
051	SDK1	[0 or 1/ 0 / 1] 0: ON. 1: OFF Determines whether certification is required before a user can use the SDK application.
061	SDK2	
071	SDK3	

5431	External Auth User	CTL	-
010	Tag		
011	Entry		
012	Group		
020	Mail		
030	Fax		
031	Fax Sub		
032	Folder		
033	Protect Code		
034	Smtplib Auth		
035	Lsapi Auth		
036	Smb Ftp Fldr Auth		
037	Acut Acl		
038	Document ACL		
040	Cert Crypt		

Appendix:
SP Mode
Tables

5481	Authentication Error Code
	These SP codes determine how the authentication failures are displayed.
001	System Log Disp
	<p>Determines whether an error code appears in the system log after a user authentication failure occurs.</p> <p>[0 to 1/0/1]</p> <p>0: Off</p> <p>1: On</p>
002	Panel Disp
	<p>Determines whether an error code appears on the operation panel after a user authentication failure occurs.</p> <p>[0 to 1/1/1]</p> <p>1: On</p> <p>0: Off</p>

5490	MF Keycard Japan Only
	Job Permit Setting
	<p>Sets up operation of the machine with a keycard.</p> <p>[0 to 1/0/1]</p> <p>0: Disabled. Cancels operation if no code is input.</p> <p>1: Enabled. Allows operation if another code is input and decrements the counter once for use of the entered code.</p>

5501	PM Alarm Interval	CTL	-
001	Printout	<p>[0 to 9999 / 0 / 1 /step]</p> <p>0: Alarm off</p> <p>1 to 9999: Alarm goes off when the PM counter reaches the specified value (1 to 9999) x 1000.</p>	
002	ADF	<p>[0 or 1 / 1 / -]</p> <p>0: No alarm sounds</p> <p>1: Alarm sounds after the number of originals passing through the A(R)DF > 10,000</p>	

5504	Jam Alarm	CTL	-
001	<p>Sets the alarm to sound for the specified jam level (document misfeeds are not included).</p> <p>[0 to 3 / 3 / 1 /step]</p> <p>0: Zero (Off), 1: Low (2.5K jams), 2: Medium (3K jams), 3: High (6K jams)</p>		

5505*	Error Alarm		
001	<p>Sets the error alarm level.</p> <p>The error alarm counter counts "1" when any SC is detected. However, the error alarm counter decreases by "1" when any SC is not detected during specified sheets of copies (for example, default 1500 sheets).</p> <p>The error alarm occurs when the SC error alarm counter reaches "5".</p> <p>[0 to 255 / 10 / 100 copies per step]</p>		

5507	Supply Alarm	CTL	-
001	Paper Size	0: Off , 1: On,	
003	Toner	0: Off , 1: On,	
005	Drum	0: Off , 1: On,	
080	Toner Call Timing	<p>0: Toner is replaced (default)</p> <p>1: Toner near end or end</p>	

Appendix:
SP Mode
Tables

System Service Mode

128	Interval :Others	[250 to 10000 / 1000 / 1 /step]
132	Interval :A3	
133	Interval :A4	
134	Interval :A5	
141	Interval :B4	
142	Interval :B5	
160	Interval :DLT	
164	Interval :LG	
166	Interval :LT	
172	Interval :HLT	

5508*	Auto Call Setting	CTL	-
001*	Jam Remains	0: Disable, 1: Enable	
	Enables/disables initiating a call for an unattended paper jam.		
002*	Frequent Jams	0: Disable, 1: Enable	
	Enables/disables initiating a call for consecutive paper jams.		
003*	Door Open	0: Disable, 1: Enable	
	Enables/disables initiating a call when the front door remains open.		
011*	Jam Remains: Time	[03 to 30 / 10 / 1 minute /step]	
	Sets the time a jam must remain before it becomes an "unattended paper jam". This setting is enabled only when SP5508 004 is set to 1.		
012*	Freq Jam: # of Time	[02 to 10 / 5 / 1 /step]	
	Sets the number of consecutive paper jams required to initiate a call. This setting is enabled only when SP5508 004 is set to 1.		

013*	Door Open: Time	[03 to 30 / 10 / 1 minute/step]
	Sets the length of time the door remains open before the machine initiates a call. This setting is enabled only when SP5508 004 is set to 1.	

5515	SC/Alarm Setting	CTL	-
	With @Remote in use, these SP codes can be set to issue an SC call when an SC error occurs. If this SP is switched off, the SC call is not issued when an SC error occurs.		
001	SC Call	[0 or 1 / 1 / -] 0: Off, 1: On	
002	Service Parts Near End		
003	Service Parts End		
004	User Call		
006	Communication Test		
007	Machine Information		
008	Alarm Notice		
010	Supply Automatic Order		
011	Supply Management Report		
012	Jam/Door Open Call	[0 or 1 / 1 / -] 0: Off,1: On	

5801	[Memory Clear] Before executing any of these SP codes, print an SMC Report.	
001	All Clear	
	Initializes items SP5801-002 to -014 below. Turn the main power switch off and on after executing this SP.	

Appendix:
SP Mode
Tables

003	SCS	-	-
	Clears the system settings.		
004	IMH	-	-
	Clears IMH data. DFU		
005	MCS	-	-
	Clears MCS data. DFU		
006	Copier	-	-
	Clears the copy application settings.		
007	Fax	-	-
	Clears the fax application settings.		
008	Printer	-	-
	Clears the printer application settings.		
009	Scanner	-	-
	Clears the scanner application settings.		
010	GWWS	-	-
	Delete the netfile application management files and thumbnails, and initializes the job login ID.		
011	NCS	-	-
	<p>Initializes the system default and interface settings (IP address also), SmartNetMonitor for Admin, WebImageMonitor settings, and the TELNET settings.</p> <p> Note</p> <ul style="list-style-type: none"> ▪ The name of Apple talk is not cleared only if this SP is executed. Turns off and on after executing this SP. 		

012	R-FAX	-	-
	Initializes the job login ID, SmartNetMonitor for Admin, job history, and local storage file numbers.		
014	Clear DCS Setting	-	-
	Initializes the DCS (Delivery Control Service) settings.		
015	Clr UCS Setting	-	-
	Initializes the UCS (User Information Control Service) settings.		
016	MIRS Setting	-	-
	Initializes the MIRS (Machine Information Report Service) settings.		
017	CCS	-	-
	Initializes the CCS (Certification and Charge-control Service) settings.		
018	SRM Memory Clr	-	-
	Initializes the SRM (System Resource Manager) settings.		
019	LCS	-	-
	Initializes the LCS (Log Count Service) settings.		
020	Web Apli	-	-
	Initializes Web application settings.		

5802	Machine Free Run	[0 or 1 / 0 / -] 0: No, 1: Yes
5802 1	Conducts machine free run (including the scanner unit). Set "1" and then press "⏻" key. Press "⏻" key again to start "Free Run". When this SP is set to "0", the machine operates normally even "⏻" key is pressed.	

Appendix:
SP Mode
Tables

5803	Input Check		
	☞ "Input Check" in this chapter.		

5804	Output Check		
	☞ "Output Check" in this chapter.		

5807*	Area Selection		
5807 1	<p>Selects the display language. 2 North America, 3 Europe, 5 Asia, 6 China SP5-807-001 is not cleared by SP5-801-002. NOTE: SC982 is displayed if you specify a language that is inconsistent with your local model.</p>		



5811*	Machine No. Setting		
001	Code Set		
	☞ "Machine No. Setting" in this section.		

5812	Service TEL		
001	Telephone	CTL	-
	<p>Sets the telephone number for a service representative. This number is printed on the Counter List, which can be printed with the user's "Counter" menu. This can be up to 20 characters (both numbers and alphabetic characters can be input).</p>		
002	Facsimile	CTL	-
	<p>Sets the fax or telephone number for a service representative. This number is printed on the Counter List. This can be up to 20 characters (both numbers and alphabetic characters can be input).</p>		

003	Supply	CTL	-
	Use this to input the telephone number of your supplier for consumables. Enter the number and press "StringIn" key. Press the "Clear modes" key to delete the telephone number.		
004	Sales	CTL	-
	Use this to input the telephone number of your sales agency. Enter the number and press #. Press the "Clear modes" key to delete the telephone number.		

5816	[NRS Function]	CTL	-
001	I/F Setting	Selects the remote service setting. [0 to 2 / 2 / 1 /step] 0: Remote service off 1: CSS remote service on 2: @Remote service on	
002	CE Call	Performs the CE Call at the start or end of the service. [0 or 1 / 0 / 1 /step] 0: Start of the service, 1: End of the service  Note <ul style="list-style-type: none"> This SP is activated only when SP 5816-001 is set to "2". 	
003	Function Flag	Enables or disables the remote service function. [0 or 1 / 0 / 1 /step] 0: Disabled, 1: Enabled	
007	SSL Disable	Uses or does not use the RCG certification by SSL when calling the RCG. [0 or 1 / 0 / 1 /step] 0: Uses the RCG certification 1: Does no use the RCG certification	

008	RCG Connect T/O	Specifies the connect timeout interval when calling the RCG. [1 to 90 / 10 / 1 second/step]
009	RCG Write Timeout	Specifies the write timeout interval when calling the RCG. [1 to 100 / 60 / 1 second/step]
010	RCG Read Timeout	Specifies the read timeout interval when calling the RCG. [1 to 100 / 60 / 1 second/step]
011	Port 80	Enables/disables access via port 80 to the SOAP method. [0 or 1 / 0 / -] 0: Disabled, 1: Enabled
013	RFU Timing	Selects the timing for the remote firmware updating. [0 or 1 / 0 / -] 0: Any status of a target machine 1: Sleep or panel off mode only
022	Install Status	
	This SP displays the RCG device installation status. 0: RCG device not registered 1: RCG device registered 2: Device registered	
023	Connect Mode (N/M)	
	This SP displays and selects the embedded RCG connection method. 0 : Internet connection 1: Dial-up connection	
061	NotiTime ExpTime DFU	
	Proximity of the expiration of the certification.	

062	<p>HTTP Proxy Use</p> <p>This SP setting determines if the proxy server is used when the machine communicates with the service center.</p>
063	<p>HTTP Proxy Host</p> <p>This SP sets the address of the proxy server used for communication between embedded RCG-N and the gateway. Use this SP to set up or display the customer proxy server address. The address is necessary to set up embedded RCG-N.</p> <p> Note</p> <ul style="list-style-type: none"> ▪ The address display is limited to 127 characters. Characters beyond the 127th character are ignored. ▪ This address is customer information and is not printed in the SMC report.
064	<p>HTTP Proxy Port</p> <p>This SP sets the port number of the proxy server used for communication between embedded RCG N and the gateway. This setting is necessary to set up embedded RCG-N.</p> <p> Note</p> <ul style="list-style-type: none"> ▪ This port number is customer information and is not printed in the SMC report.
065	<p>HTTP Proxy Aut Usr</p> <p>This SP sets the HTTP proxy authentication user name.</p> <p> Note</p> <ul style="list-style-type: none"> ▪ The length of the name is limited to 31 characters. Any character beyond the 31st character is ignored. ▪ This name is customer information and is not printed in the SMC report.

066	HTTP Proxy Aut Pass	
	<p>This SP sets the HTTP proxy authentication password.</p> <p> Note</p> <ul style="list-style-type: none"> ▪ The length of the password is limited to 31 characters. Any character beyond the 31st character is ignored. ▪ This name is customer information and is not printed in the SMC report. 	
067	Cer Updt Cond	
	Displays the status of the certification update.	
	0	The certification used by embedded RCG is set correctly.
	1	The certification request (setAuthKey) for update has been received from the GW URL and certification is presently being updated.
	2	The certification update is completed and the GW URL is being notified of the successful update.
	3	The certification update failed, and the GW URL is being notified of the failed update.
	4	The period of the certification has expired and a new request for an update is being sent to the GW URL.
	11	A rescue update for certification has been issued and a rescue certification setting is in progress for the rescue GW connection.
	12	The rescue certification setting is completed and the GW URL is being notified of the certification update request.
	13	The notification of the request for certification update has been completed successfully, and the system is waiting for the certification update request from the rescue GW URL
	14	The notification of the certification request has been received from the rescue GW controller, and the certification is being stored.
15	The certification has been stored, and the GW URL is being notified of the successful completion of this event.	

	16	The storing of the certification has failed, and the GW URL is being notified of the failure of this event.
	17	The certification update request has been received from the GW URL, the GW URL was notified of the results of the update after it was completed, but a certification error has been received, and the rescue certification is being recorded.
	18	The rescue certification of No. 17 has been recorded, and the GW URL is being notified of the failure of the certification update.
068	Cer Abnml Cause	
	Displays a number code that describes the reason for the request for update of the certification.	
	0	Normal. There is no request for certification update in progress.
	1	Request for certification update in progress. The current certification has expired.
	2	An SSL error notification has been issued (after the certification has expired).
	3	Notification of shift from a common authentication to an individual certification.
	4	Notification of a common certification without ID2.
	5	Notification that no certification was issued.
6	Notification that GW URL does not exist.	
069	Cer: Updtt ReqID	
	The ID of the request for certification.	
083	Firm Updating	
	Displays the status of the firmware update.	

Appendix:
SP Mode
Tables

085	Firm Up Usr Conf
	This SP setting determines if the operator can confirm the previous version of the firmware before the firmware update execution. If the option to confirm the previous version is selected, a notification is sent to the system manager and the firmware update is done with the firmware files from the URL.
086	Firmware Size
	Allows the service technician to confirm the size of the firmware data files during the firmware update execution.
087	CERT: Macro Vsn
	Displays the macro version of the @Remote certification.
088	CERT: PAC Vsn
	Displays the PAC version of the @Remote certification.
089	CERT: ID2 Code
	Displays ID2 for the @Remote certification. Spaces are displayed as underscores (_). Asterisks (*) indicate that no @Remote certification exists.
090	CERT: Subject
	Displays the common name of the @Remote certification subject. CN = the following 17 bytes. Spaces are displayed as underscores (_). Asterisks (*) indicate that no DESS exists.
091	CERT: Seri Num
	Displays serial number for the @Remote certification. Asterisks (*) indicate that no DESS exists.
092	CERT: Issuer
	Displays the common name of the issuer of the @Remote certification. CN = the following 30 bytes. Asterisks (*) indicate that no DESS exists.

093	CERT: St ExpTime
	Displays the start time of the period for which the current @Remote certification is enabled.
094	CERT: End ExpTime
	Displays the end time of the period for which the current @Remote certification is enabled.
150	Ins Country
	<p>Select from the list the name of the country where embedded RCG-M is installed in the machine. After selecting the country, you must also set the following SP codes for embedded RCG-M:</p> <ul style="list-style-type: none"> ▪ SP5816-153 ▪ SP5816-154 ▪ SP5816-161 <p>0: Japan, 1: USA, 2: Canada, 3: UK, 4: Germany, 5: France 6: Italy, 7: Netherlands, 8: Belgium, 9: Luxembourg, 10: Spain</p>
151	Aut Line Detect
	<p>Press [Execute].</p> <p>Setting this SP classifies the telephone line where embedded RCG-M is connected as either dial-up or push type, so embedded RCG-M can automatically distinguish the number that connects to the outside line.</p> <ul style="list-style-type: none"> ▪ The current progress, success, or failure of this execution can be displayed with SP5816 152. ▪ If the execution succeeded, SP5816 153 will display the result for confirmation and SP5816 154 will display the telephone number for the connection to the outside line.

152	Line Detect Rst
	Displays a number to show the result of the execution of SP5816 151. Here is a list of what the numbers mean.
	<p>0: Success 1: In progress (no result yet). Please wait. 2: Line abnormal 3: Cannot detect dial tone automatically 4: Line is disconnected 5: Insufficient electrical power supply 6: Line classification not supported 7: Error because fax transmission in progress – ioctl() occurred. 8: Other error occurred 9: Line classification still in progress. Please wait.</p>
153	Dial/Push Select
	<p>This SP displays the classification (tone or pulse) of the telephone line to the access point for embedded RCG-M. The number displayed (0 or 1) is the result of the execution of SP5816 151. However, this setting can also be changed manually.</p> <p>[0 to 1 / 0 / 1 /step]</p> <p>0: Tone Dialing Phone 1: Pulse Dialing Phone</p> <p>Inside Japan "2" may also be displayed:</p> <p>0: Tone Dialing Phone 1: Pulse Dialing Phone 10PPS 2: Pulse Dialing Phone 20PPS</p>

154	Outline Phone #
	<p>The SP sets the number that switches to PSTN for the outside connection for embedded RCG-M in a system that employs a PBX (internal line).</p> <ul style="list-style-type: none"> ▪ If the execution of SP5816-151 has succeeded and embedded RCG-M has connected to the external line, this SP display is completely blank. ▪ If embedded RCG-M has connected to an internal line, then the number of the connection to the external line is displayed. ▪ If embedded RCG-M has connected to an external line, a comma is displayed with the number. The comma is inserted for a 2 sec. pause. ▪ The number setting for the external line can be entered manually (including commas).
156	Dial Up User
	<p>Use this SP to set a user name for access to remote dial up. Follow these rules when setting a user name:</p> <ul style="list-style-type: none"> ▪ Name length: Up to 32 characters ▪ Spaces and # allowed but the entire entry must be enclosed by double quotation marks (").
157	Dial Up Password
	<p>Use this SP to set a password for access to remote dial up. Follow these rules when setting a user name:</p> <ul style="list-style-type: none"> ▪ Name length: Up to 32 characters ▪ Spaces and # allowed but the entire entry must be enclosed by double quotation marks (").
161	Phone Number
	<p>Use this SP to set the telephone number of the line where embedded RCG-M is connected. This number is transmitted to and used by the Call Center to return calls.</p> <p>Limit: 24 numbers (numbers only)</p>

162	<p>Ans Timing Adj</p> <p>When the Call Center calls out to a embedded RCG-M modem, it sends a repeating ID tone (*#1#). This SP sets the time the line remains open to send these ID tones after the number of the embedded RCG-M modem is dialed up and connected.</p> <p>[0 to 24/ 1 /1 /step]</p> <p>The actual amount of time is this setting + 2 sec. For example, if you set "2" the line will remain open for 4 sec.</p>
163	<p>Access Point</p> <p>This is the number of the dial-up access point for embedded RCG-M. If no setting is done for this SP code, then a preset value (determined by the country selected) is used.</p> <p>Default: 0</p> <p>Allowed: Up to 16 alphanumeric characters</p>
164	<p>Comm Line</p> <p>This SP sets the connection conditions for the customer. This setting dedicates the line to embedded RCG-M only, or sets the line for sharing between embedded RCG-M and a fax unit.</p> <p>[0 or 1 / 0 / -]</p> <p>0: Line shared by embedded RCG-M/Fax</p> <p>1: Line dedicated to embedded RCG-M only</p> <p> Note</p> <ul style="list-style-type: none"> ▪ If this setting is changed, the copier must be cycled off and on. ▪ SP5816 187 determines whether the off-hook button can be used to interrupt an embedded RCG-M transmission in progress to open the line for fax transaction.
173	<p>Modem Serial Number</p> <p>This SP displays the serial number registered for the embedded RCG-M.</p>

	Lmt Resend Cncl
174	<p>Normally, it is best to allow unlimited time for certification and ID2 update requests, and for the notification that the certification has been completed.</p> <p>However, embedded RCG-M generates charges based on transmission time for the customer, so a limit is placed upon the time allowed for these transactions.</p> <p>If these transactions cannot be completed within the allowed time, do this SP to cancel the time restriction.</p>
186	RCG-C M Debut Bit SW DFU
	FAX TX Priority
187	<p>This SP determines whether pushing the off-hook button will interrupt an embedded RCG-M transmission in progress to open the line for fax transaction. This SP can be used only if SP5816-164 is set to "0".</p> <p>[0 or 1/ 0 / -]</p> <p>0: Disable. Setting the fax unit off-hook does not interrupt a fax transaction in progress. If the off-hook button is pushed during a embedded RCG-M transmission, the button must be pushed again to set the fax unit on-hook after the embedded RCG-M transmission has completed.</p> <p>1: Enable. When embedded RCG-M shares a line with a fax unit, setting the fax unit off-hook will interrupt a embedded RCG-M transmission in progress and open the line for a fax transaction.</p>
200	Polling Man Exc
	Executes the polling test.

201	Instl: Condition
	<p>Displays a number that indicates the status of the @Remote service device.</p> <p>0: Neither the registered device by the external RCG nor embedded RCG device is set.</p> <p>1: The embedded RCG device is being set. Only Box registration is completed. In this status the this unit cannot answer a polling request from the external RCG.</p> <p>2: The embedded RCG device is set. In this status the external RCG unit cannot answer a polling request.</p> <p>3: The registered device by the external RCG is being set. In this status the embedded RCG device cannot be set.</p> <p>4: The registered module by the external RCG has not started.</p>
202	Instl: ID#
	Allows entry of the number of the request needed for the embedded RCG.
203	Instl: Reference
	Executes the inquiry request to the @Remote GateWay URL.
204	Instl: Ref Rslt
	<p>Displays a number that indicates the result of the inquiry executed with SP5816-203.</p> <p>0: Succeeded</p> <p>1: Inquiry number error</p> <p>2: Registration in progress</p> <p>3: Proxy error (proxy enabled)</p> <p>4: Proxy error (proxy disabled)</p> <p>5: Proxy error (Illegal user name or password)</p> <p>6: Communication error</p> <p>7: Certification update error</p> <p>8: Other error</p> <p>9: Inquiry executing</p>

205	Instl: Ref Section		
	Displays the result of the notification sent to the device from the GW URL in answer to the inquiry request. Displayed only when the result is registered at the GW URL.		
206	Instl: Rgslttn		
	Executes Embedded RCG Registration.		
207	Instl: Rgslttn Rst		
	<p>Displays a number that indicates the registration result.</p> <p>0: Succeeded</p> <p>2: Registration in progress</p> <p>3: Proxy error (proxy enabled)</p> <p>4: Proxy error (proxy disabled)</p> <p>5: Proxy error (Illegal user name or password)</p> <p>6: Communication error</p> <p>7: Certification update error</p> <p>8: Other error</p> <p>9: Registration executing</p>		
208	Instl Error Code		
	Displays a number that describes the error code that was issued when either SP5816 204 or SP5816 207 was executed.		
	Cause	Code	Meaning
	Illegal Modem Parameter	-11001	Chat parameter error
		-11002	Chat execution error
		-11003	Unexpected error
	Operation Error, Incorrect Setting	-12002	Inquiry, registration attempted without acquiring device status.
-12003		Attempted registration without execution of an inquiry and no previous registration.	
-12004		Attempted setting with illegal entries for	

			certification and ID2.
	Error Caused by Response from GW URL	-2385	Attempted dial up overseas without the correct international prefix for the telephone number.
		-2387	Not supported at the Service Center
		-2389	Database out of service
		-2390	Program out of service
		-2391	Two registrations for same device
		-2392	Parameter error
		-2393	External RCG not managed
		-2394	Device not managed
		-2395	Box ID for external RCG is illegal
		-2396	Device ID for external RCG is illegal
		-2397	Incorrect ID2 format
		-2398	Incorrect request number format
209	Instl Clear		
	Releases a machine from its embedded RCG setup.		
250	Print Com Log		
	Prints the communication log.		

5821	NRS Address	
002	RCG IP Address	Sets the IP address of the RCG (Remote Communication Gate) destination for call processing at the remote service center. [00000000h to FFFFFFFFh / 1 /step]

5824	NVRAM Upload
5824 1	👉 "NVRAM Upload/Download" in this section.

5825	NVRAM Download
5825 1	👉 "NVRAM Upload/Download" in this section.

5828	Network Setting	CTL	
050	1284 Compatibility (Centro)	Enables or disables 1284 Compatibility. [0 or 1 / 1 / 1 / step] 0: Disabled, 1: Enabled	
052	ECP (Centro)	Enables or disables ECP Compatibility. [0 or 1 / 1 / 1 / step] 0: Disabled, 1: Enabled NOTE: This SP is activated only when SP5-828-50 is set to "1".	
065	Job Spooling	Enables/disables Job Spooling. [0 or 1 / 0 / 1 / step] 0: Disabled, 1: Enabled	
066	Job Spooling Clear: Start Time	Treatment of the job when a spooled job exists at power on. 0: ON (Data is cleared) 1: OFF (Automatically printed)	
069	Job Spooling (Protocol)	Validates or invalidates the job spooling function for each protocol. 0: Validates 1: Invalidates bit0: LPR bit1: FTP bit2: IPP bit3: SMB bit4: BMLinkS	



5828	Network Setting	CTL	
		bit5: DIPRINT bit6: (Reserved) bit7: (Reserved)	
090	TELNET (0: OFF 1: ON)	Enables or disables the Telnet protocol. [0 or 1 / 1 / -] 0: Disable, 1: Enable	
091	Web (0: OFF 1: ON)	Enables or disables the Web operation. [0 or 1 / 1 / -] 0: Disable, 1: Enable	
	Active IPv6 Link		
145	This is the IPv6 local address link referenced on the Ethernet or wireless LAN (802.11b) in the format: "Link Local Address" + "Prefix Length" The IPv6 address consists of a total of 128 bits configured in 8 blocks of 16 bits each.		
147	Active IPv6 Status Address 1	These SPs are the IPv6 status addresses (1 to 5) referenced on the Ethernet or wireless LAN (802.11b) in the format: "Status Address" + "Prefix Length" The IPv6 address consists of a total of 128 bits configured in 8 blocks of 16 bits each.	
149	Active IPv6 Status Address 2		
151	Active IPv6 Status Address 3		
153	Active IPv6 Status Address 4		
155	Active IPv6 Status Address 5		
	IPv6 Manual Setting Address		
156	This SP is the IPv6 manually set address referenced on Ethernet or wireless LAN (802.11b) in the format: "Manual Set Address" + "Prefix Length" The IPv6 address consists of a total of 128 bits configured in 8 blocks of 16		

5828	Network Setting	CTL	
	bits each.		
158	IPv6 Gateway Address		
	This SP is the IPv6 gateway address referenced on Ethernet or wireless LAN (802.11b). The IPv6 address consists of a total of 128 bits configured in 8 blocks of 16 bits each.		
161	IPv6 Stateless Auto Setting		
	Enables/disables the stateless automatic setting for Ethernet/wireless LAN operation. [0 to 1/1/1] 1: Enable 0: Disable		
236	Web Item Invisible		
	Determines whether each item can be set in Websys. [0x0000 to 0xffff/0xffff] Bit 1: NetRICOH Bit2: Vendor for consumables Bit2-15: Reserved		
237	Web Shopping Link Invisible		
	Determines whether the NetRICOH link is displayed on the Websys top page and link page. [0 to 1/1/1] 1: Display 0: No display		
238	Web Supplies Link Invisible		
	Determines whether the consumable vendor link is displayed on the Websys top page and link page. [0 to 1/1/1] 1: Display 0: No display		
239	Web Link 1 Name Determines whether a name entered for "URL1" is displayed on the Websys		

5828	Network Setting	CTL	
	link page. The name length is limited to 31 characters.		
240	Web Link 1 URL Sets the URL referenced for URL1 linked to the Websys linked page. The link name is limited to 127 characters.		
241	Web Link 1 Visible Determines whether the link for URL1 is displayed on the Websys top page. [0 to 1/1/1] 1: Display 0: No display		
242	Web Link 2 Name Determines whether a name entered for "URL2" is displayed on the Websys link page. The name length is limited to 31 characters.		
243	Web Link 2 URL Sets the URL referenced for URL2 linked to the Websys linked page. The link name is limited to 127 characters.		
244	Web Link 2 Visible Determines whether the link for URL2 is displayed on the Websys top page. [0 to 1/1/1] 1: Display 0: No display		

5832	HDD
	Enter the SP number for the partition to initialize, then press #. When the execution ends, cycle the machine off and on.
001	HDD Formatting (All)
002	HDD Formatting (IMH)
003	Format Thumbnail
004	Format Job Log
005	Format Font

006	Format User Info
007	Format Rec Mail
008	Format Sed Mail
009	Format DFU data
010	Format All Log
011	Format Ridoc I/F

5840	IEEE 802.11		
006	Channel MAX	CTL	[1 to 11 or 13 / 11 or 13 / 1 /step] Europe: 1 to 13, default: 13 NA/ Asia: 1 to 11, default: 11
	<p>Sets the maximum number of channels available for data transmission via wireless LAN. The number of channels available varies according to location. The default settings are set for the maximum end of the range for each area. Adjust the upper 4 bits to set the maximum number of channels. DFU</p> <p> Note</p> <ul style="list-style-type: none"> Do not change the setting. 		
007	Channel MIN	CTL	[1 to 11 or 13 / 1 / 1 /step] Europe: 1 to 13 NA/ Asia: 1 to 11
	<p>Sets the minimum number of channels available for data transmission via the wireless LAN. The number of channels available varies according to location. The default settings are set for the minimum end of the range for each area. Adjust the lower 4 bits to set the minimum number of channels. DFU</p> <p> Note</p> <ul style="list-style-type: none"> Do not change the setting. 		
011	WEP Key Select	CTL	[00 to 11 / 00 / 1 binary] 00: Key #1 01: Key #2 (Reserved) 10: Key #3 (Reserved) 11: Key #4 (Reserved)

	Selects the WEP key.		
042	Fragment Thresh	CTL	[256 to 2346 / 2346 / 1]
	Adjusts the fragment threshold for the IEEE802.11 card. This SP is displayed only when the IEEE802.11 card is installed.		
043	11g CTS to Self	CTL	[0 to 1 / 1 / 1] 0: Off, 1: On
	Determines whether the CTS self function is turned on or off. This SP is displayed only when the IEEE802.11 card is installed.		
044	11g Slot Time	CTL	[0 to 1 / 1 / 1] 0: 20µm, 1: 9µm
	Selects the slot time for IEEE802.11.		
045	WPA Debug Lvl	CTL	[0 to 3 / 3 / 1] 1: Info, 2: Warning, 3: Error
	Selects the debug log for WPA authentication application. This SP is displayed only when the IEEE802.11 card is installed.		

5842	GWWS Analysis DFU		
001	Setting 1	CTL	
	This is a debugging tool. It sets the debugging output mode of each Net File process. Default: Bit SW 1000 0000	Bit	Groups
		0	System & other groups (LSB)
		1	Capture related
		2	Certification related
		3	Address book related
		4	Machine management related
		5	Output related (printing, delivery)
		6	Repository related
7	Debug log output		

002	Setting 2	CTL	
	Default: Bit SW 0000 0000	Bit	Groups
		0-6	Not used
		7	Log time stamp setting 0: Date/Hour/Minute/Second 1: Minute/Second/Msecond

5844	USB		
001	Transfer Rate	CTL	
	Sets the speed for USB data transmission. [Full Speed] [Auto Change]		
002	Vendor ID	CTL	
	Sets the vendor ID: Initial Setting: 0x05A Ricoh Company [0x0000 to 0xFFFF/1] DFU		
003	Product ID	CTL	
	Sets the product ID. [0x0000 to 0xFFFF/1] DFU		
004	Device Release No.	CTL	
	Sets the device release number of the BCD (binary coded decimal) display. [0000 to 9999/1] DFU Enter as a decimal number. NCS converts the number to hexadecimal number recognized as the BCD.		

5845	Delivery Server Setting	CTL	-
	Provides items for delivery server settings.		
001	FTP Port Num	[0 to 65535 / 3670 / 1 /step]	
	Sets the FTP port number used when image files to the Scan Router Server.		
002	Srv IP (Primary)	Range: 000.000.000.000 to 255.255.255.255	
	Use this SP to set the Scan Router Server address. The IP address under the transfer tab can be referenced by the initial system setting.		
003	Retry Interval	[60 to 999 / 300 / 1 second /step]	
	Specifies the interval time for sending the scanned image data to the deliver server or SMTP/FTP/NCP/SMB server after sending error.		
004	No. of Retries	[0 to 99 / 3 / 1 time/step]	
	Specifies the retry times for sending the scanned image data to the deliver server or SMTP/FTP/NCP/SMB server after sending error.		
006	DeliErr DispTime	[0 to 999 / 300 / 1 second /step]	
	Use this setting to determine the length of time the prompt message is displayed when a test error occurs during document transfer with the NetFile application and an external device.		
008	Srv IP (Secondary)	Range: 000.000.000.000 to 255.255.255.255	
	Specifies the IP address assigned to the computer designated to function as the secondary delivery server of Scan Router. This SP allows only the setting of the IP address without reference to the DNS setting.		
009	Deli Svr Model	[0 to 4 / 0 / 1 /step]	
	Allows changing the model of the delivery server registered by the I/O device. 0: Unknown, 1: SG1 Provided, 2: SG1 Package, 3: SG2 Provided, 4: SG2 Package		

010	Deli Svr Capabty	[0 to 255 / 0 / 1 /step]
	Bit7 = 1 Comment information exists	Changes the capability of the server that is registered as an I/O device.
	Bit6 = 1 Direct specification of mail address possible	
	Bit5 = 1 Mail RX confirmation setting possible	
	Bit4 = 1 Address book automatic update function exists	
	Bit3 = 1 Fax RX delivery function exists	
	Bit2 = 1 Sender password function exists	
	Bit1 = 1 Function to link MK-1 user and Sender exists	
	Bit0 = 1 Sender specification required (if set to 1, Bit6 is set to "0")	
011	Delivery Svr Cap (Ext)	[0 to 255 / 0 / 1 /step]
	Changes the capability of the server that is registered as an I/O device.	
013	Svr Schm (Primary)	-
	Specifies the scheme of the primary delivery server.	
014	Svr Port Num (Pri)	-
	Specifies the port number of the primary delivery server.	
015	Srv URL Path (Pri)	-
	Specifies the URL path of the primary delivery server.	

Appendix:
SP Mode
Tables

016	Svr Schm (Sec)	-
	Specifies the scheme of the secondary delivery server.	
017	Svr Port Num (Sec)	-
	Specifies the port number of the secondary delivery server.	
018	Srv URL Path (Sec)	-
	Specifies the URL path of the secondary delivery server.	
022	Instant Trans Off	[0 or 1 / 1 / -] 0: Disable, 1: Enable
	Enables or disables the prevention function for the continuous data sending.	

5846	UCS Settings	CTL
	Provides items for delivery server settings.	
001	Machine ID (DelSvy)	Displays ID
	Displays the unique device ID in use by the delivery server directory. The value is only displayed and cannot be changed. This ID is created from the NIC MAC or IEEE 1394 EUI. The ID is displayed as either 6-byte or 8-byte binary.	
002	MC ID Clr (DelSvy)	Clears ID
	Clears the unique ID of the device used as the name in the file transfer directory. Execute this SP if the connection of the device to the delivery server is unstable. After clearing the ID, the ID will be established again automatically by cycling the machine off and on.	
003	Maximum Entries	[150 to 999 / 150 / 1 /step]
	Changes the maximum number of entries that UCS can handle. If a value smaller than the present value is set, the UCS managed data is cleared, and the data (excluding user code information) is displayed.	

006	Delsvr Rtry Tmer	[0 to 255 / 0 / 1 /step]
	Sets the interval for retry attempts when the delivery server fails to acquire the delivery server address book.	
007	Delsvr Rtry Tmes	[0 to 255 / 0 / 1 /step]
	Sets the number of retry attempts when the delivery server fails to acquire the delivery server address book.	
008	Delsvr Maxentri	[200 to 999 / 200 / 1/step]
	Sets the maximum number account entries of the delivery server user information managed by UCS.	
010	LDAP Search Tout	[1 to 255 / 60 / 1 /step]
	Sets the length of the timeout for the search of the LDAP server.	
020	WSD Max Entries	[5 to 255 / 250 / 1 /step]
	Sets the maximum entries for the address book of the WSD (SD-scanner)	
021	Folder Auth chg	[0 or 1 / 0 / -] 0: Login user name 1: address book
041	[AddrB Acl Info] Address Book Access Control List Information	
	This SP must be executed immediately after installation of an HDD unit in a basic machine that previously had no HDD. The first time the machine is powered on with the new HDD installed, the system automatically takes the address book from the NVRAM and writes it onto the new HDD. However, the new address book on the HDD can be accessed only by the system administrator at this stage. Executing this SP by the service technician immediately after power on grants full address book access to all users.	
043	Addr B Media	
	Displays the slot number where an address book data is in.	

047	Ini Local Addr B	Clears the local address book information, including the user code.
048	Ini Deli Addr B	Clears the distribution address book information, except the user code.
049	Ini LDAP Addr B	Clears the LDAP address book information, except the user code.
050	Ini All Addr B	Clears all directory information managed by UCS, including all user codes. Turn the main power switch off and on after executing this SP.
051	Bkup All Addr B	Uploads all directory information to the SD card.
052	Restr All Addr B	Downloads all directory information from the SD card.
053	Clear Backup Info	Deletes the address book data from the SD card in the service slot. Deletes only the files that were uploaded from this machine. This feature does not work if the card is write-protected. Note: After you do this SP, go out of the SP mode, and then turn the power off. Do not remove the SD card until the Power LED stops flashing.
060	Search Option	This SP uses bit switches to set up the fuzzy search options for the UCS local address book. Bit0: Checks both upper/lower case characters Bit1: Japan only Bit2 to 7: Not used

062	Compl Opt1 ⁽¹⁾	Use this SP to set the conditions for password entry to access the local address book. Specifically, this SP limits the password entry to upper case and sets the length of the password. [0 to 32 / 0 / 1 /step]
063	Compl Opt2 ⁽¹⁾	Use this SP to set the conditions for password entry to access the local address book. Specifically, this SP limits the password entry to lower case and defines the length of the password. [0 to 32 / 0 / 1 /step]
064	Compl Opt3 ⁽¹⁾	Use this SP to set the conditions for password entry to access the local address book. Specifically, this SP limits the password entry to numbers and defines the length of the password. [0 to 32 / 0 / 1 /step]
065	Compl Opt4 ⁽¹⁾	Use this SP to set the conditions for password entry to access the local address book. Specifically, this SP limits the password entry to symbols and defines the length of the password. [0 to 32 / 0 / 1 /step]
091	FTP Auth Port Setting	Specifies the FTP port for getting a distribution server address book that is used in the identification mode. [0 to 65535 / 3671 / 1 /step]
094	Encryption Stat	Shows the status of the encryption function for the address book data.

Note ⁽¹⁾:

SP5846-062 to SP5846-065 do not normally require adjustment.

These SP modes are enabled only after the system administrator has set up a group password policy to control access to the address book.

	Web Service	CTL	-
5848	SP5848-1 sets the 4-bit switch assignment for the access control setting. Setting of 0001 has no effect on access and delivery from Scan Router. ac: Access Control		
002	Ac: Repo (only Lower 4 Bits)	Switches access control on and off. 0000 : No access control 0001: Denies access to DeskTop Binder.	
004	ac: UD (only Lower 4 bits)		
005	ac: For Cherry (only Lower 4 bits)		
007	ac: Log Fax (Lower 4 bits)		
009	ac: Job Ctrl (Lower 4 bits)		
011	ac: Dev Mng (Lower 4 bits)		
022	ac: Uadmin (Lower 4bits)		
099	DL Image Setting		
100	Max. Size: DL Image	[1 to 1024/1 K]	
210	Log Type: Job1	Displays the log server settings. These can be adjusted with the Web Image Monitor.	
211	Log Type: Job2		
212	Log Type: Access		
213	Primary Srv		
214	Secondary Srv		
215	Start Time		
216	Interval Time	Specifies the transmit interval. [1 to 1000 / 1 / 1 hour/step] This SP is activated only when SP5848-217 is set to "2 (Transmit periodically)".	

217	Timing	Selects the transmit timing. [0 to 2 / 0 / 1/step] 0: No Transmit, 1: Transmit one by one 2: Transmit periodically
-----	--------	---

5849	Installation Date	CTL	
	Displays or prints the installation date of the machine.		
001	Display	The "Counter Clear Day" has been changed to "Installation Date" or "Inst. Date".	
002	Print	Determines whether the installation date is printed on the printout for the total counter. [0 or 1/ 1 / 1/step] 0: Off (No Print), 1: On (Print)	
003	Total Counter	Displays the total counter when the installation date is registered to the machine.	

5851	Bluetooth		
001	Mode	CTL	Sets the operation mode for the Bluetooth Unit. Press either key. 0 :Public, 1: Private

5856	Remote ROM Update		
	Allows the technician to upgrade the firmware using a parallel cable when updating the remote ROM.		
002	Local Port	CTL	[0 or 1 / 0 / 1/step] 0: Disallow 1: Allow

Appendix:
SP Mode
Tables

5857	Debug Log Save	CTL	-
	ON/OFF	0: OFF, 1: ON	
001	Switches the debug log feature on and off. The debug log cannot be captured until this feature is switched on.		
	Target (2: HDD 3: SD)		
002	Selects the destination where the debugging information generated by the event selected by SP5858 will be stored if an error is generated [2 to 3 /1] 2: HDD 3: SD Card		
	Save to HDD		
005	Specifies the decimal key number of the log to be written to the hard disk.		
	Save to SD Card		
006	Specifies the debug log number for saving to an SD card.		
	HDD to SD Card Latest		
009	Takes the most recent 4 MB of the log written to the hard disk and copies them to the SD Card. A unique file name is generated to avoid overwriting existing file names on the SD Card. Up to 4MB can be copied to an SD Card. 4 MB segments can be copied one by one to each SD Card.		
	HDD to SD Any		
010	Takes the log of the specified key from the log on the hard disk and copies it to the SD Card. A unique file name is generated to avoid overwriting existing file names on the SD Card. Up to 4 MB can be copied to an SD Card. 4 MB segments can be copied one by one to each SD Card. This SP does not execute if there is no log on the HDD with no key specified.		

011	Erase HDD Debug Data
	Erases all debug logs on the HDD
012	Erase SD Debug
	Erases SD debug logs in the SD card. Turn off and on after executing this SP.
013	Dsply-SD Space
	Displays the remaining space in the SD card.
014	SD to SD Latest (Latest 4 MB)
	Saves the debug log (latest 4 MB) in memory to the SD card. A unique file name is generated to avoid overwriting existing file names on the SD card. Up to 4MB can be copied to the SD card. 4 MB segments can be copied one by one to the SD card.
015	SD to SD Any (Latest 4 MB Any Key)
	Saves the specified debug log (with SP5-857-006) in memory to the SD card. A unique file name is generated to avoid overwriting existing file names on the SD card. Up to 4MB can be copied to the SD card. 4 MB segments can be copied one by one to the SD card.
016	Make HDD Debug
	This SP creates a 32 MB file to store a log on the HDD.
017	Make SD Debug
	Executes the making of a file (4MB) for saving debug logs.

5858	Debug Log Save: SC	CTL	-
	<p>These SPs select the content of the debugging information to be saved to the destination selected by SP5857-2.</p> <p>SP5858-3 stores one SC specified by number. Refer to the chapter "Trouble Shooting" for a list of SC error codes.</p>		
001	Engine SC	<p>Turns the save function on/off for SC codes generated by copier engine errors.</p> <p>[0 or 1 / 0 / 1/ step]</p> <p>0: OFF, 1: ON</p>	
002	Controller SC	<p>Turns the save function on/off for SC codes generated by GW controller errors.</p> <p>[0 or 1 / 0 / 1/ step]</p> <p>0: OFF, 1: ON</p>	
003	Any SC	[0 to 65535 / 0 / 1 /step]	
004	Jam	<p>Turns the save function on/off for jam errors.</p> <p>[0 or 1 / 0 / 1/ step]</p> <p>0: OFF, 1: ON</p>	

5859	Debug Log Save Key	CTL	-
001	Key 1	<p>These SPs allow you to set up to 10 keys for log files for functions that use common memory on the controller board.</p> <p>[-9999999 to 9999999 / 0 / -]</p>	
002	Key 2		
003	Key 3		
004	Key 4		
005	Key 5		
006	Key 6		
007	Key 7		
008	Key 8		
009	Key 9		

010	Key 10		
5860	SMTP/POP3/IMAP4	CTL	-
	Par Mail Rec Tout	[1 to 168 / 72 / 1 hour/step]	
020	Sets the amount of time to wait before saving mail that breaks up during reception. The received mail is discarded if the remaining portion of the mail is not received during this prescribed time.		
	MDN Res RFC2298	[0 to 1 / 1 / -]	
021	Determines whether RFC2298 compliance is switched on for MDN reply mail. 0: No, 1: Yes		
	SMTP Aut Field Rep	[0 to 1 / 0 / -]	
022	Determines whether the FROM item of the mail header is switched to the validated account after the SMTP server is validated. 0: No. "From" item not switched. 1: Yes. "From" item switched.		
	SMTP Aut. Direct Set	[0 or 1 / 0 / -]	
025	<p>Selects the authentication method for SMPT.</p> <p>Bit switch:</p> <ul style="list-style-type: none"> ▪ Bit 0: LOGIN ▪ Bit 1: PLAIN ▪ Bit 2: CRAM MD5 ▪ Bit 3: DIGEST MD5 ▪ Bit 4 to 7: Not used <p> Note</p> <ul style="list-style-type: none"> ▪ This SP is activated only when SMTP authorization is enabled by UP mode. 		
026	S/MINE Header		

5866	E-mail Report		
001	Report Validity	-	[0 or 1 / 0 / -] 0: Enabled, 1: Disabled
	Enables or disables the E-mail alert function.		
005	Add Date Field	CTL	[0 or 1 / 0 / -] 0: Not add, 1: Add
	Adds or does not add the date field to the header of the alert mail.		

5869	RAM Disk Setting		
001	Mail Function	GWINIT	[0 or 1 / 0 / -] 0: ON, 1: OFF
	Turns on or off the e-mail function.		

5870	Common Key Info Writing		
001	Writing	CTL	Writes to flash ROM the common proof for validating the device for @Remote specifications.
003	Initialize	CTL	Formats the common proof area of the flash ROM. FA

5873	SD Card Appli Move	
001	Move Exec	This SP copies the application programs from the original SD card in SD card slot 3 to an SD card in SD card slot 2.
002	Undo Exec	This SP copies back the application programs from an SD card in the SD Card Slot 3 to the original SD card in the SD card slot 2. Use this menu when you have mistakenly copied some programs by using "Move Exec" (SP5873-1).

5875	SC Auto Reboot		
001	Reboot Mode	CTL	<p>Enables or disables the automatic reboot function when an SC error occurs.</p> <p>[0 or 1 / 0 / -]</p> <p>0: The machine reboots automatically when the machine issues an SC error and logs the SC error code. If the same SC occurs again, the machine does not reboot.</p> <p>1: The machine does not reboot when an SC error occurs.</p> <p>The reboot is not executed for Type A, B or C SC codes.</p>
002	Reboot Method	CTL	<p>Selects the reboot method for SC.</p> <p>[0 or 1 / 0 / -]</p> <p>0: Manual reboot, 1: Automatic reboot</p>

5878	Option Setup		
001	Data Overwrite Security	-	<p>Enables the Data Overwrite Security unit.</p> <p>Press "EXECUTE" on the operation panel.</p> <p>Then turn the machine off and on.</p>
002	Encryption Option	-	

5881	Delete Fixed Sent		
001	Delete Fixed Sent	-	Deletes the fixed form sentence.

5885	Set WIM Function		
200	Detect Mem Leak		
201	DocSvr Timeout		

5887	SD GetCounter SSP
001	This SP saves the counter list of the machine to an SD card in the slot 3. The folder of "SD_COUNTER" must be made in an SD card for this SP.

5888*	Person Info Prot
	Selects the protection level for logs. [0 to 1 / 0 / 1} 0: No authentication, No protection for logs 1: No authentication, Protected logs (an administrator can see the logs)

5893	[SDK Apli Cnt Name]	*CTL	-
	Displays the counter name of each SDK application.		
001	SDK-1		
002	SDK-2		
003	SDK-3		
004	SDK-4		
005	SDK-5		
006	SDK-6		

5902	Test Pattern Print
5902 1	 "Test Pattern Print" in this section.

5907*	Plug & Play
5907 1	Selects the brand name and production name for the Plug and Play function. These names are stored in the NVRAM. When the NVRAM data is corrupted, select these names once again. Use the right-arrow or left-arrow key to scroll through the list of brand names. To select a brand name, press the OK key. An asterisk (*) indicates which manufacture is currently selected.

5912*	PCU Alarm Counter	[0 to 255 / 45 / 1/step]
5912 1	Printout	
	Specifies the PCU alarm level. The PCU alarm is issued when the following condition is met: $P_{Ac} \times 1000 \geq PCU_c$ where P_{Ac} is the value specified in this SP and PCU_c is the PCU counter. When you specify 0 (zero), the PCU alarm is deactivated.	

5913	Switch Permission
002	Print Application
	Sets the length of time to elapse before allowing another application to take control of the display when the application currently controlling the display is not operating because a key has not been pressed. [3 to 30 / 3 / 1 second/step]

5974	Cherry Server
001	Selects which version of the Scan Router application program, "Light" or "Full (Professional)", is installed. [0 to 1 / 0 / 1 /step] 0: Light version (supplied with this machine) 1: Full version (optional)





5985	Device Setting	
	The NIC and USB support features are built into the GW controller. Use this SP to enable and disable these features. In order to use the NIC and USB functions built into the controller board, these SP codes must be set to "1".	
001	On Board NIC	<p>[0 to 2 / 0 / 1 /step] 0: OFF, 1: ON, 2: ON: Limited When the "Function limitation" is set, "On board NIC" is limited only for the @Remote or LDAP/NT authentication.</p> <p> Note</p> <ul style="list-style-type: none"> Other network applications than @Remote or LDAP/NT authentication are not available when this SP is set to "2". Even if you can change the initial settings of those network applications, settings may not actually work.
002	On Board USB	<p>[0 or 1 / 0 / 1/step] 0: OFF, 1: ON</p>

5990	SP Print Mode	SMC Print
	In the SP mode, press Copy Window to move to the copy screen, select the paper size, then press Start. Select A4/LT (Sideways) or larger to ensure that all the information prints. Press SP Window to return to the SP mode, select the desired print, and press "EXECUTE".	
001	All (Data List)	
002	SP (Mode Data List)	
003	User Program	
004	Logging Data	
005	Diagnostic Report	
006	Non-Default (Prints only SPs set to values other than defaults.)	

007	NIB Summary
021	Copier UP
022	Scanner SP
023	Scanner UP

5998	Engine Memory Clear
001	See the section "Memory Clear" in this chapter.

SP6-XXX (Peripherals)

6006*	ADF Adjustment (☛ "DF Image Adjustment" in the "Adjusting Copy Image Area") NOTE: Available menus depend on the machine model and its configuration.	
001	StoS/Front Regist	[-5.0 to +5.0 / 0.0 / 0.1 mm/step]
	Adjusts the side-to-side registration for the front side of the original, for ARDF mode. Use the  key to select "+" or "-" before entering the value	
002	Leading Regist	[-5.0 to +5.0 / 0.0 / 0.1 mm/step]
	Adjusts the leading edge registration for ARDF mode. Use the  key to select "+" or "-" before entering the value.	
003	Trailing Erase	[-3.0 to +3.0 / -1.5 / 0.1 mm/step]
	Adjusts the trailing edge erase margin for ARDF mode. Use the  key to select "+" or "-" before entering the value.	
004	S to S/ Rear Regist	[-5.0 to +5.0 / 0.0 / 0.1 mm/step]
	Adjusts the side-to-side registration for the 2nd side of the original, for ARDF mode. Use the  key to select "+" or "-" before entering the value	
005	Sub-scan Magnif	[-0.9 to +0.9 / 0.0 / 0.1 %/step]
	Adjusts the sub-scan magnification for the ARDF.	
006	Origin Curl Adj	[0 = No / 1 = Yes]
	Turns on or off the skew correction at 2nd side scanning. This SP is activated only when the duplex mode is selected.	
007	Skew Correction	[-20 to +20 / 0.0 / 1 mm/step]
	Adjusts the original buckle for the skew correction at 2ns side scanning. This SP is activated only when SP6-006-006 is set to "1 (Yes)".	

6009	ADF Free Run	
001	Duplex Mode	
	Performs an ARDF free run in duplex scanning mode. Press "ON" to start; press "OFF" to stop.	
003	Simplex Mode	
	Performs an ARDF free run at simplex scanning mode. Press "ON" to start; press "OFF" to stop.	

6910*	ADF Shading Time	[0 to 60 / 30 / 1 s/step]
001	Adjusts the interval used for the shading processing in the ARDF mode. Light and heat in the room may affect the scanner response. Reduce this setting if copy quality indicates that the white level is drifting during ARDF copy jobs.	

6930*	ADF Hole Setting	[0 or 1 / 0 / -] 0 : No, 1: Yes
001	Enables or disables the ADF hole setting. When "1: Yes" is selected, the machine prevents feed jams of the punched originals in the ARDF.	

SP7-XXX (Data Log)

7001*	Total Operation	
001	Displays the total operation time (total drum rotation time).	

7401*	Total SC Counter	[0 to 9999 / 0 / 1/step]
001	Displays how many times SC codes are generated.	

7403*	SC History	
001	Latest	Displays the most recent 10 service calls.
002	Latest 1	
003	Latest 2	
004	Latest 3	
005	Latest 4	
006	Latest 5	
007	Latest 6	
008	Latest 7	
009	Latest 8	
010	Latest 9	

7502*	Counter–Paper Jam	[0 to 9999 / 0 / 1/step]
001	Displays the total number of copy paper jams.	

7503*	Counter–Orgn Jam	[0 to 9999 / 0 / 1/step]
001	Displays the total number of original jams,	

7504*	Paper Jam/Loc	[0 to 9999 / 0 / 1/step]
	Displays the total number of the paper jams classified by timing and location.	
001	At power on	
	Paper jam occurs at power on.	
010	Regist NoFeed: OFF	
	Paper does not reach the registration sensor (from a paper tray).	
011	1 Vertical SN: OFF	
	Paper does not reach the relay sensor.	
012	1 Vertical SN: ON	
	Paper is caught at the relay sensor.	
021	Vertical SN: OFF	
	Paper does not reach the vertical transport sensor.	
022	Vertical SN: ON	
	Paper is caught at the vertical transport sensor.	
050	Regist Bypass: OFF	
	Paper does not reach the registration sensor (from the by-pass tray).	
060	Regist Duplex: OFF	
	Paper does not reach the registration sensor during reverse-side printing (for duplex printing).	
070	Regist SN: ON	
	Paper is caught at the registration sensor.	
120	1 Exit SN: ON	
	Paper is caught at the exit sensor (previous page).	

121	Exit SN: OFF
	Paper does not reach the exit sensor.
122	2 Exit SN: ON
	Paper is caught at the exit sensor.
123	Dup Inverter: OFF
	Paper does not reach the duplex inverter sensor (from the registration roller).
125	Dup Inverter: ON
	Paper is caught at the duplex inverter sensor.

7505	Original Jam Location
	<p>Displays the total number of original jams by location. These jams occur when the original does not activate the sensors.</p> <p>Note</p> <ul style="list-style-type: none"> ▪ Lag: Jam occurs when the paper remains at the sensor for longer than the prescribed time. ▪ Late: Jam occurs because paper fails to arrive at the prescribed time.
210	Regist SN: OFF
211	Regist SN: ON
212	Paper Exit SN: OFF
213	Paper Exit SN: ON
214	Inverter: OFF
215	Inverter: ON

7506	[Paper Jam/ Size] Jam Counter: Paper Size			
006	A5 LEF	CTL	Displays the number of jams according to the paper size. [0 to 9999 / 0 / 1 sheet/step]	
044	HLT LEF			
133	A4 SEF			
134	A5 SEF			
142	B5 SEF			
164	LG SEF			
166	LT SEF			
172	HLT SEF			
255	Others			

Appendix:
SP Mode
Tables

7507*	Dsply-P Jam Hist				
001	Lastest	Displays the copy jam history (the most recent 10 jams) Sample Display: CODE:007 SIZE:05h TOTAL:0000334 DATE: Mon Mar 15 11:44:50 2000 where: CODE is the SP7504-*** number (see above). SIZE is the ASAP paper size code in hex. TOTAL is the total jam error count (SP7502) DATE is the date the jams occurred.			
002	Latest 1				
003	Latest 2				
004	Latest 3				
005	Latest 4				
006	Latest 5				
007	Latest 6				
008	Latest 7				
009	Latest 8				
010	Latest 9				
Size	Code	Size	Code	Size	Code
A4 (S)	05	A3 (L)	84	DLT (L)	A0

System Service Mode

A5 (S)	06	A4 (L)	85	LG (L)	A4
B5 (S)	0E	A5 (L)	86	LT (L)	A6
LT (S)	26	B4 (L)	8D	HLT (L)	AC
HLT (S)	2C	B5 (L)	8E	Others	FF

7508*	Dsply-O Jam History	
001	Lastest	<p>Displays the original jam history (the most recent 10 jams).</p> <p>Sample Display:</p> <p>CODE:007</p> <p>SIZE:05h</p> <p>TOTAL:0000334</p> <p>DATE: Mon Mar 15 11:44:50 2000</p> <p>where:</p> <p>CODE is the SP7505*** number (see above).</p> <p>SIZE is the ASAP paper size code in hex.</p> <p>TOTAL is the total error count (SP7503)</p> <p>DATE is the date the jams occurred.</p>
002	Last 1	
003	Last 2	
004	Last 3	
005	Last 4	
006	Last 5	
007	Last 6	
008	Last 7	
009	Last 8	
010	Last 9	

7624	Part Replacement	
001	PCU	Selects the PM maintenance for PCU.

7801	Memory/Version/PN	
255	-	Displays the he part number and version of all ROMs in the machine

7803*	PM Counter	
001	Paper	Displays the PM counter.

7804	PM Count Reset	
001	Paper	
	Resets the PM counter (SP7-803-001). When the program ends normally, the message "Completed" is displayed.	

7807	Reset-SC/Jam	
001	Resets the SC, paper, original, and total jam counters. When the program ends normally, the message "Completed" is displayed. SP7-807-1 does not reset the following logs: SP7-507 (Display-Paper Jam History) and SP7-508 (Display-Original Jam History).	

7826	MF Error Counter Japan Only	
	Displays the number of counts requested of the card/key counter.	
001	Error Total	A request for the count total failed at power on. This error will occur if the device is installed but disconnected.
002	Error Staple	The request for a staple count failed at power on. This error will occur if the device is installed but disconnected.

7827	MF Error Counter Clear	
	Press Execute to reset to 0 the values of SP7826. Japan Only	

7832*	Display-Self-Diag
001	Displays the SC codes and the number of their occurrences. Each number is in the range of 0 to 9999.

7836	[Resident Memory]
	Displays the contents of the memory on the controller board.

7901	Assert Info		
	Records the location where a problem is detected in the program. The data stored in this SP is used for problem analysis. DFU		
001	File Name	-	-
002	Number of Lines	-	-
003	Location	-	-

7991*	Dsply-Info Count		
	Displays the total operating time or the total number of operations. The time is displayed in the following format: day: hour: minute: second.		
003	Dsply-ID S Work		
	The total of the time when the ID sensor is working.		
004	Dsply-Dev Counter		
	The total number of paper outputs.		
005	Dsply-ID Er Count		
	The total number of ID-sensor errors.		

7992*	Reset-Info Count
004	Reset-Dev Count
	Clears the development counter (SP7-991-004).
005	Reset-ID Er Count
	Clears the ID sensor error counter (SP7-991-005).

SP8-XXX (History)

Most of the SPs in this group are prefixed with a letter that indicates the mode of operation (the mode of operation is referred to as an "application"). Before reading the Group 8 Service Table, make sure that you understand what these prefixes mean.

Prefixes	What it means	
T:	Total: (Grand Total).	Grand total of the items counted for all applications (C, F, P, etc.)..
C:	Copy application.	Totals (pages, jobs, etc.) executed for each application when the job was not stored on the document server.
F:	Fax application.	
P:	Print application.	
S:	Scan application.	
O:	Other applications (external network applications, for example)	Refers to network applications such as Web Image Monitor. Utilities developed with the SDK (Software Development Kit) will also be counted with this group in the future.

The Group 8 SP codes are limited to 17 characters, forced by the necessity of displaying them on the small LCDs of printers and faxes that also use these SPs. Read over the list of abbreviations below and refer to it again if you see the name of an SP that you do not understand.

Key for Abbreviations

Abbreviation	What it means
/	"By", e.g. "T:Jobs/Apl" = Total Jobs "by" Application
>	More (2> "2 or more", 4> "4 or more")
AddBook	Address Book
Apl	Application
B/W	Black & White
Bk	Black
C	Cyan
ColCr	Color Create
ColMode	Color Mode
Comb	Combine
Comp	Compression
Deliv	Delivery
DesApl	Designated Application. The application (Copy, Fax, Scan, Print) used to store the job on the document server, for example.
Dev Counter	Development Count, no. of pages developed.
Dup, Duplex	Duplex, printing on both sides
Emul	Emulation
FC	Full Color
FIN	Post-print processing, i.e. finishing (punching, stapling, etc.)
Full Bleed	No Margins
GenCopy	Generation Copy Mode
GPC	Get Print Counter. For jobs 10 pages or less, this counter does not count up. For jobs larger than 10 pages, this counter counts

Abbreviation	What it means
	up by the number that is in excess of 10 (e.g., for an 11-page job, the counter counts up 11-10 =1)
IFax	Internet Fax
ImgEdt	Image Edit performed on the original with the copier GUI, e.g. border removal, adding stamps, page numbers, etc.
K	Black (YMCK)
LS	Local Storage. Refers to the document server.
LSize	Large (paper) Size
Mag	Magnification
MC	One color (monochrome)
NRS	NRS (@Remote), which allows a service center to monitor machines remotely. "@Remote" is used overseas; "CSS" is used in Japan.
Org	Original for scanning
OrgJam	Original Jam
Palm 2	Print Job Manager/Desk Top Editor: A pair of utilities that allows print jobs to be distributed evenly among the printers on the network, and allows files to moved around, combined, and converted to different formats.
PC	Personal Computer
PGS	Pages. A page is the total scanned surface of the original. Duplex pages count as two pages, and A3 simplex count as two pages if the A3/DLT counter SP is switched ON.
PJob	Print Jobs
Ppr	Paper
PrtJam	Printer (plotter) Jam

Abbreviation	What it means
PrtPGS	Print Pages
R	Red (Toner Remaining). Applies to the wide format model A2 only. This machine is under development and currently not available.
RCG	Remote Communication Gate
Rez	Resolution
SC	Service Code (Error SC code displayed)
Scn	Scan
Sim, Simplex	Simplex, printing on 1 side.
S-to-Email	Scan-to-E-mail
SMC	SMC report printed with SP5990. All of the Group 8 counters are recorded in the SMC report.
Svr	Server
TonEnd	Toner End
TonSave	Toner Save
TXJob	Send, Transmission
YMC	Yellow, Magenta, Cyan
YMCK	Yellow, Magenta, Cyan, Black

 Note



- All of the Group 8 SPs are reset with SP5 801 1 Memory All Clear.

8 191	T:Total Scan PGS	CTL	These SPs count the pages scanned by each application that uses the scanner to scan images. [0 to 99999999 / 0 / 1]
8 192	C:Total Scan PGS	CTL	
8 193	F:Total Scan PGS	CTL	
8 195	S:Total Scan PGS	CTL	

- SP 8 191 to 8 196 count the number of scanned sides of pages, not the number of physical pages.
- These counters do not count reading user stamp data, or reading color charts to adjust color.
- Previews done with a scanner driver are not counted.
- A count is done only after all images of a job have been scanned.
- Scans made in SP mode are not counted.

Examples

- If 3 B5 pages and 1 A3 page are scanned with the scanner application but not stored, the S: count is 4.
- If both sides of 3 A4 sheets are copied and stored to the document server using the Store File button in the Copy mode window, the C: count is 6 and the L: count is 6.
- If both sides of 3 A4 sheets are copied but not stored, the C: count is 6.
- If you enter document server mode then scan 6 pages, the L: count is 6.

8 201	T:LSize Scan PGS	CTL	[0 to 99999999 / 0 / 1]
	<p>These SPs count the total number of large pages input with the scanner for scan and copy jobs. Large size paper (A3/DLT) scanned for fax transmission is not counted.</p> <p> Note</p> <ul style="list-style-type: none"> ▪ These counters are displayed in the SMC Report, and in the User Tools display. 		
8 203	F:LSize Scan PGS	CTL	[0 to 99999999 / 0 / 1]
	<p>These SPs count the number of large pages scanned by original type for Fax jobs.</p>		
8 205	S:LSize Scan PGS	CTL	[0 to 99999999 / 0 / 1]
	<p>These SPs count the total number of large pages input with the scanner for scan jobs only. Large size paper (A3/DLT) scanned for fax transmission are not counted.</p> <p> Note</p> <ul style="list-style-type: none"> ▪ These counters are displayed in the SMC Report, and in the User Tools display. 		

8 221	ADF Org Feeds	CTL	[0 to 99999999 / 0 / 1]
	These SPs count the number of pages fed through the ADF for front and back side scanning.		
001	Front	<p>Number of front sides fed for scanning: With an ADF/ARDF that can scan both sides simultaneously, the Front side count is the same as the number of pages fed for either simplex or duplex scanning. With an ADF/ARDF that cannot scan both sides simultaneously, the Front side count is the same as the number of pages fed for duplex front side scanning. (The front side is determined by which side the user loads face up.)</p>	
002	Back	<p>Number of rear sides fed for scanning: With an ADF/ARDF that can scan both sides simultaneously, the Back count is the same as the number of pages fed for duplex scanning. With an ADF/ARDF that cannot scan both sides simultaneously, the Back count is the same as the number of pages fed for duplex rear-side scanning.</p>	

- When 1 sheet is fed for duplex scanning the Front count is 1 and the Back count is 1.
- If a jam occurs during the job, recovery processing is not counted to avoid double counting. Also, the pages are not counted if the jam occurs before the first sheet is output.

8 281	T:Scan PGS/TWAIN	CTL	<p>These SPs count the number of pages scanned using a TWAIN driver. These counters reveal how the TWAIN driver is used for delivery functions.</p> <p>[0 to 99999999 / 0 / 1]</p> <p> Note</p> <ul style="list-style-type: none"> ▪ At the present time, these counters perform identical counts.
8 285	S:Scan PGS/TWAIN	CTL	

8 291	T:Scan PGS/Stamp	CTL	These SPs count the number of pages stamped with the stamp in the ADF unit. [0 to 99999999 / 0 / 1]
8 293	F:Scan PGS/Stamp	CTL	
8 295	S:Scan PGS/Stamp	CTL	

8 301	T:Scan PGS/Size	CTL	[0 to 99999999 / 0 / 1]
	These SPs count by size the total number of pages scanned by all applications. Use these totals to compare original page size (scanning) and output (printing) page size [SP 8-441].		
8 302	C:Scan PGS/Size	CTL	[0 to 99999999 / 0 / 1]
	These SPs count by size the total number of pages scanned by the Copy application. Use these totals to compare original page size (scanning) and output (printing) page size [SP 8-442].		
8 303	F:Scan PGS/Size	CTL	[0 to 99999999 / 0 / 1]
	These SPs count by size the total number of pages scanned by the Fax application. Use these totals to compare original page size (scanning) and output page size [SP 8-443].		
8 305	S:Scan PGS/Size	CTL	[0 to 99999999 / 0 / 1]
	These SPs count by size the total number of pages scanned by the Scan application. Use these totals to compare original page size (scanning) and output page size [SP 8-445].		
001	A3	-	
002	A4		
003	A5		
004	B4		
005	B5		
006	DLT		
007	LG		

008	LT	
009	HLT	
010	Full Bleed	
254	Other (Standard)	
255	Other (Custom)	

8 381	T:Total PrtPGS	CTL	These SPs count the number of pages printed by the customer. The counter for the application used for storing the pages increments. [0 to 99999999 / 0 / 1]
8 382	C:Total PrtPGS	CTL	
8 383	F:Total PrtPGS	CTL	
8 384	P:Total PrtPGS	CTL	
8 385	S:Total PrtPGS	CTL	
8 387	O:Total PrtPGS	CTL	

- When the A3/DLT double count function is switched on with SP5104, 1 A3/DLT page is counted as 2.
- When several documents are merged for a print job, the number of pages stored is counted for the application that stored them.
- These counters are used primarily to calculate charges on use of the machine, so the following pages are not counted as printed pages:
 - Blank pages in a duplex printing job.
 - Blank pages inserted as document covers, chapter title sheets, and slip sheets.
 - Reports printed to confirm counts.
 - All reports done in the service mode (service summaries, engine maintenance reports, etc.)
 - Test prints for machine image adjustment.
 - Error notification reports.
 - Partially printed pages as the result of a copier jam.

8 391	LSize PrtPGS	CTL	[0 to 99999999 / 0 / 1]
	<p>These SPs count pages printed on paper sizes A3/DLT and larger.</p> <p> Note</p> <ul style="list-style-type: none"> In addition to being displayed in the SMC Report, these counters are also displayed in the User Tools display on the copy machine. 		

8 411	Prints/Duplex	CTL	<p>This SP counts the amount of paper (front/back counted as 1 page) used for duplex printing. Last pages printed only on one side are not counted.</p> <p>[0 to 99999999 / 0 / 1]</p>
--------------	---------------	-----	--

8 421	T:PrtPGS/Dup Comb	CTL	[0 to 99999999 / 0 / 1]
	<p>These SPs count by binding and combine, and n-Up settings the number of pages processed for printing. This is the total for all applications.</p>		
8 422	C:PrtPGS/Dup Comb	CTL	[0 to 99999999 / 0 / 1]
	<p>These SPs count by binding and combining, and n-Up settings the number of pages processed for printing by the copier application.</p>		
8 423	F:PrtPGS/Dup Comb	CTL	[0 to 99999999 / 0 / 1]
	<p>These SPs count by binding and combining, and n-Up settings the number of pages processed for printing by the fax application.</p>		
8 424	P:PrtPGS/Dup Comb	CTL	[0 to 99999999 / 0 / 1]
	<p>These SPs count by binding and combining, and n-Up settings the number of pages processed for printing by the printer application.</p>		

8 425	S:PrtPGS/Dup Comb	CTL	[0 to 99999999 / 0 / 1]
	These SPs count by binding and combining, and n-Up settings the number of pages processed for printing by the scanner application.		
8 427	O:PrtPGS/Dup Comb	CTL	[0 to 99999999 / 0 / 1]
	These SPs count by binding and combining, and n-Up settings the number of pages processed for printing by Other applications		
001	Simplex> Duplex	-	
002	Duplex> Duplex	-	
003	Book> Duplex	-	
004	Simplex Combine	-	
005	Duplex Combine	-	
006	2>	2 pages on 1 side (2-Up)	
007	4>	4 pages on 1 side (4-Up)	
008	6>	6 pages on 1 side (6-Up)	
009	8>	8 pages on 1 side (8-Up)	
010	9>	9 pages on 1 side (9-Up)	
011	16>	16 pages on 1 side (16-Up)	
012	Booklet	-	
013	Magazine	-	

- These counts (SP8-421 to SP8-427) are especially useful for customers who need to improve their compliance with ISO standards for the reduction of paper consumption.
- Pages that are only partially printed with the n-Up functions are counted as 1 page.
- Here is a summary of how the counters work for Booklet and Magazine modes:

Booklet		Magazine	
Original Pages	Count	Original Pages	Count
1	1	1	1
2	2	2	2
3	2	3	2
4	2	4	2
5	3	5	4
6	4	6	4
7	4	7	4
8	4	8	4

8 441	T:PrtPGS/Ppr Size	CTL	[0 to 99999999 / 0 / 1]
	These SPs count by print paper size the number of pages printed by all applications.		
8 442	C:PrtPGS/Ppr Size	CTL	[0 to 99999999 / 0 / 1]
	These SPs count by print paper size the number of pages printed by the copy application.		
8 443	F:PrtPGS/Ppr Size	CTL	[0 to 99999999 / 0 / 1]
	These SPs count by print paper size the number of pages printed by the fax application.		
8 444	P:PrtPGS/Ppr Size	CTL	[0 to 99999999 / 0 / 1]
	These SPs count by print paper size the number of pages printed by the printer application.		

8 445	S:PrtPGS/Ppr Size	CTL	[0 to 99999999 / 0 / 1]
	These SPs count by print paper size the number of pages printed by the scanner application.		
8 447	O:PrtPGS/Ppr Size	CTL	[0 to 99999999 / 0 / 1]
	These SPs count by print paper size the number of pages printed by Other applications.		
001	A3	-	
002	A4		
003	A5		
004	B4		
005	B5		
006	DLT		
007	LG		
008	LT		
009	HLT		
010	Full Bleed		
254	Other (Standard)	-	
255	Other (Custom)		

Appendix:
SP Mode
Tables

- These counters do not distinguish between LEF and SEF.

8 451	PrtPGS/Ppr Tray	CTL	[0 to 99999999 / 0 / 1]
	These SPs count the number of sheets fed from each paper feed station.		
001	Bypass	Bypass Tray	
002	Tray 1	Copier	
003	Tray 2	Copier	
004	Tray 3	Copier	
005	Tray 4	Currently not used.	
006	Tray 5	Currently not used.	
007	Tray 6	Currently not used.	
008	Tray 7	Currently not used.	
009	Tray 8	Currently not used.	
010	Tray 9	Currently not used.	
011	Tray 10	Currently not used.	
012	Tray 11	Currently not used.	
013	Tray 12	Currently not used.	
014	Tray 13	Currently not used.	
015	Tray 14	Currently not used.	
016	Tray 15	Currently not used.	

8 461	T:PrtPGS/Ppr Type	CTL	[0 to 99999999 / 0 / 1]
	<p>These SPs count by paper type the number pages printed by all applications.</p> <ul style="list-style-type: none"> ▪ These counters are not the same as the PM counter. The PM counter is based on feed timing to accurately measure the service life of the feed rollers. However, these counts are based on output timing. ▪ Blank sheets (covers, chapter covers, slip sheets) are also counted. ▪ During duplex printing, pages printed on both sides count as 1, and a page printed on one side counts as 1. 		
8 462	C:PrtPGS/Ppr Type	CTL	[0 to 99999999 / 0 / 1]
	<p>These SPs count by paper type the number pages printed by the copy application.</p>		
8 463	F:PrtPGS/Ppr Type	CTL	[0 to 99999999 / 0 / 1]
	<p>These SPs count by paper type the number pages printed by the fax application.</p>		
8 464	P:PrtPGS/Ppr Type	CTL	[0 to 99999999 / 0 / 1]
	<p>These SPs count by paper type the number pages printed by the printer application.</p>		
001	Normal		
002	Recycled		
003	Special		
004	Thick		
005	Normal (Back)		
006	Thick (Back)		
007	OHP		
008	Other		

8 521	T:PrtPGS/FIN	CTL	[0 to 99999999 / 0 / 1]
	These SPs count by finishing mode the total number of pages printed by all applications.		
8 522	C:PrtPGS/FIN	CTL	[0 to 99999999 / 0 / 1]
	These SPs count by finishing mode the total number of pages printed by the Copy application.		
8 523	F:PrtPGS/FIN	CTL	[0 to 99999999 / 0 / 1]
	<p>These SPs count by finishing mode the total number of pages printed by the Fax application.</p> <p> Note</p> <ul style="list-style-type: none"> ▪ Print finishing options for received faxes are currently not available. 		
8 524	P:PrtPGS/FIN	CTL	[0 to 99999999 / 0 / 1]
	These SPs count by finishing mode the total number of pages printed by the Print application.		
8 525	S:PrtPGS/FIN	CTL	[0 to 99999999 / 0 / 1]
	These SPs count by finishing mode the total number of pages printed by the Scanner application.		
001	Sort		
002	Stack		
003	Staple		
004	Booklet		
005	Z-Fold		
006	Punch		
007	Other		

Note

- If stapling is selected for finishing and the stack is too large for stapling, the unstapled pages are still counted.
- The counts for staple finishing are based on output to the staple tray, so jam recoveries are counted.

8 581	T:Counter	CTL	[0 to 99999999 / 0 / 1]
	This SP counts the total output broken down by color output, regardless of the application used. In addition to being displayed in the SMC Report, these counters are also displayed in the User Tools display on the copy machine.		
001	Total		

8 591	O:Counter	CTL	[0 to 99999999 / 0 / 1]
8 591 1	A3/DLT	These SPs count the totals for A3/DLT paper use, number of duplex pages printed, and the number of staples used. These totals are for Other (O:) applications only.	
8 591 2	Duplex		

8 601	Cvg Counter	CTL	[0 to 99999999 / 0 / 1]
8 601 1	Cvg: BW %	Displays the total coverage of each mode.	
8 601 11	Cvg: BW Pages	Displays the number of the printouts in each mode.	

8 631	T:FAX TX PGS	CTL	[0 to 99999999 / 0 / 1]
	This SP counts by color mode the number of pages sent by fax to a telephone number.		
8 633	F:FAX TX PGS	CTL	[0 to 99999999 / 0 / 1]
	This SP counts by color mode the number of pages sent by fax to a telephone number.		
001	B/W		

- If a document has color and black-and-white pages mixed, the pages are counted separately as B/W or Color.
- At the present time, this feature is provided for the Fax application only so SP8631 and SP8633 are the same.
- The counts include error pages.
- If a document is sent to more than one destination with a Group transmission, the count is done for each destination.
- Polling transmissions are counted but polling RX are not.
- Relay, memory, and confidential mailbox transmissions and are counted for each destination.

8 641	T:IFAX TX PGS	CTL	[0 to 99999999 / 0 / 1]
	This SP counts by color mode the number of pages sent by fax to as fax images using I-Fax.		
8 643	F:IFAX TX PGS	CTL	[0 to 99999999 / 0 / 1]
	This SP counts by color mode the number of pages sent by Fax as fax images using I-Fax.		
001	B/W		

- If a document has color and black-and-white pages mixed, the pages are counted separately as B/W or Color.
- At the present time, this feature is provided for the Fax application only so SP8641 and SP8643 are the same.
- The counts include error pages.
- If a document is sent to more than one destination with a Group transmission, the count is done for each destination.
- Polling transmissions are counted but polling RX are not.
- Relay, memory, and confidential mailbox transmissions and are counted for each destination.

8 651	T:S-to-Email PGS	CTL	[0 to 99999999 / 0 / 1]
	This SP counts by color mode the total number of pages attached to an e-mail for both the Scan and document server applications.		
8 655	S:S-to-Email PGS	CTL	[0 to 99999999 / 0 / 1]
	This SP counts by color mode the total number of pages attached to an e-mail for the Scan application only.		
001	B/W		
002	Color		

 Note

- The count for B/W and Color pages is done after the document is stored on the HDD. If the job is cancelled before it is stored, the pages are not counted.
- If Scan-to-Email is used to send a 10-page document to 5 addresses, the count is 10 (the pages are sent to the same SMTP server together).
- If Scan-to-PC is used to send a 10-page document to 5 folders, the count is 50 (the document is sent to each destination of the SMB/FTP server).
- Due to restrictions on some devices, if Scan-to-Email is used to send a 10-page document to a large number of destinations, the count may be divided and counted separately. For example, if a 10-page document is sent to 200 addresses, the count is 10 for the first 100 destinations and the count is also 10 for the second 100 destinations, for a total of 20.).

System Service Mode

8 661	T:Deliv PGS/Svr	CTL	[0 to 99999999 / 0 / 1]
	These SPs count by color mode the total number of pages sent to a Scan Router server by both Scan and LS applications.		
8 665	S:Deliv PGS/Svr	CTL	[0 to 99999999 / 0 / 1]
	These SPs count by color mode the total number of pages sent to a Scan Router server by the Scan application.		
001	B/W		
002	Color		

Note

- The B/W and Color counts are done after the document is stored on the HDD of the Scan Router server.
- If the job is canceled before storage on the Scan Router server finishes, the count is not done.
- The count is executed even if there is confirmation of the arrival at the Scan Router server.

8 671	T:Deliv PGS/PC	CTL	[0 to 99999999 / 0 / 1]
	These SPs count by color mode the total number of pages sent to a folder on a PC (Scan-to-PC) with the Scan and LS applications.		
8 675	S:Deliv PGS/PC	CTL	[0 to 99999999 / 0 / 1]
	These SPs count by color mode the total number of pages sent with Scan-to-PC with the Scan application.		
001	B/W		
002	Color		

Note

- Print jobs done with Web Image Monitor and Desk Top Binder are added to the count.
- If several documents are merged for sending, the number of pages stored are counted for the application that stored them.
- When several documents are sent by a Fax broadcast, the F: count is done for the number of pages sent to each destination.

8 681	T:PCFAX TXPGS	CTL	These SPs count the number of pages sent by PC Fax. These SPs are provided for the Fax application only, so the counts for SP8-681 and SP8-683 are the same. [0 to 99999999 / 0 / 1]
8 683	F:PCFAX TXPGS	CTL	

Appendix:
SP Mode
Tables

- This counts pages sent from a PC using a PC fax application, from the PC through the copier to the destination.
- When sending the same message to more than one place using broadcasting, the pages are only counted once. (For example, a 10-page fax is sent to location A and location B. The counter goes up by 10, not 20.)

	TX PGS/Port	CTL	[0 to 99999999 / 0 / 1]
8 701	These SPs count the number of pages sent by the physical port used to send them. For example, if a 3-page original is sent to 4 destinations via ISDN G4, the count for ISDN (G3, G4) is 12.		
001	PSTN-1	-	
002	PSTN-2	-	
003	PSTN-3	-	
004	ISDN (G3,G4)	-	
005	Network	-	

8 711	T:Scan PGS/Comp	CTL	[0 to 99999999 / 0 / 1]
8 715	S:Scan PGS/Comp	CTL	[0 to 99999999 / 0 / 1]
	These SPs count the number of pages sent by each compression mode.		
-001	JPEG/JPEG2000	-	
-002	TIFF M/S (Multi/Single)	-	
-003	PDF	-	
-004	Other	-	

8741	RX PGS/Port		[0 to 99999999 / 0 / 1]
	These SPs count the number of pages received by the physical port used to receive them.		
001	PSTN-1		
002	PSTN-2		
003	PSTN-3		
004	ISDN (G3,G4)		
005	Network		

8 771	Dev Counter	CTL	[0 to 999999999 / 0 / 1]
	This SP counts the total number of developed images.		
001	Total		

8 781	Toner Botol Info.	*BICU	[0 to 99999999/ 0 / 1]
	This SP counts the total number of developed images.		
001	Total		

8 801	Toner Remain	CTL	[0 to 100 / 0 / 1]
	<p>This SP displays the percent of toner remaining for each color. This SP allows the user to check the toner supply at any time.</p> <p>Note</p> <ul style="list-style-type: none"> This precise method of measuring remaining toner supply (1% steps) is better than other machines on the market that can only measure in increments of 10 (10% steps). 		
001	K		

8 851	Cvr Cnt:0-10%	*BICU	[0 to 99999999/ 0 / 1]
	These SPs display the number of scanned sheets on which the coverage of each color is from 0% to 10%.		
011	0-2%:Bk		
021	3-4%: Bk		
031	5-7%: Bk		
041	8-10%: Bk		

8 861	Cvr Cnt: 11-20%	*BICU	[0 to 99999999/ 0 / 1]
	These SPs display the number of scanned sheets on which the coverage of each color is from 11% to 20%.		
001	Bk		

8 871	Cvr Cnt: 21-30%	*BICU	[0 to 99999999/ 0 / 1]
	These SPs display the number of scanned sheets on which the coverage of each color is from 21% to 30%.		
001	Bk		

8 881	Cvr Cnt: 31%-	*BICU	[0 to 99999999/ 0 / 1]
	These SPs display the number of scanned sheets on which the coverage of each color is 31% or higher.		
001	Bk		

8 891	Page/Toner Bottle	*BICU	[0 to 99999999/ 0 / 1]
	This SP displays the number of sheets output by the scan application.		
001	Bk		

8 901	Page/Toner k Prev1	*BICU	[0 to 99999999/ 0 / 1]
	This SP displays the number of sheets output by the scan application with the previously replaced units.		
001	Bk		

8 911	Page/Toner k Prev2	*BICU	[0 to 99999999/ 0 / 1]
	This SP displays the number of sheets output by the scan application with the unit replaced before the previously replaced unit (two steps back from the current unit).		
001	Bk		

8 921	Cvr Cnt/Total	*BICU	
001	Coverage(%): BK	[0 to 2147483647 / 0 / 1] These SPs display the total coverage percentage of sheets output by the machine.	
011	Covwerage/P: Bk	[0 to 999999999 / 0 / 1] These SPs display the total coverage pages output by the machine.	

8 941	Machine Status	CTL	[0 to 999999999 / 0 / 1]
	These SPs count the amount of time the machine spends in each operation mode. These SPs are useful for customers who need to investigate machine operation for improvement of their compliance with ISO Standards.		
001	Operation Time	Engine operation time. Does not include time while controller is saving data to HDD (while engine is not operating).	
002	Standby Time	Engine not operating. Includes time while controller saves data to HDD. Does not include time spent in Energy Save, Low Power, or Off modes.	
003	Energy Save Time	Includes time while the machine is performing background printing.	
004	Low Power Time	Includes time in Energy Save mode with Engine on. Includes time while machine is performing background printing.	
005	Off Mode Time	Includes time while machine is performing background printing. Does not include time machine remains powered off with the power switches.	

Appendix:
SP Mode
Tables

System Service Mode

006	SC	Total down time due to SC errors.
007	PrtJam	Total down time due to paper jams during printing.
008	OrgJam	Total down time due to original jams during scanning.
009	Supply PM Unit End	Total down time due to toner end.

8 999	AdominCounter	CTL	[0 to 9999999 / 0 / 1]
	Displays the user setting counter for administrator.		
001	Total	-	
003	Copy: BW	-	
007	Printer: BW	-	
010	FaxP: BW	-	
013	Duplex	-	
015	Cvr: BW %	-	
017	Cvr: BW Pages	-	
101	SedTtl: FC		
102	SendTtl: BW	-	
103	FaxSend	-	
104	FaxSend: BW		
105	FaxSend: BW	-	

3.1.2 INPUT CHECK (SP5-803)

Conducting Input Check

1. Select SP5-803.
2. Select the number (see the table below) corresponding to the component.
3. Select "Execute." The copy mode is activated.
4. The sign "01H" or "00H" is displayed (see the table below).

Input Check Table

Num.	Sensor/Switch	1h	0h
001	Safety SW	Open	Closed
003	Right Cover SW	Open	Closed
006	Upper Relay S	Paper detected	Not detected
007	Lower Relay S	Paper detected	Not detected
009	Regist Sensor	Paper detected	Not detected
010	Exit Sensor	Paper detected	Not detected
011	Duplex Inverter S	Paper detected	Not detected
014	By-pass PE S	Paper detected	Not detected
016	Upper PE S	Paper detected	Not detected
017	BK-Upper PE S	Paper detected	Not detected
020	BK-Lower PE S	Paper detected	Not detected
027	PCU Set Signal	Installed	Not installed
028	BK type	*	*
030	Duplex Installed	Installed	Not installed
032	Main M Lock	Locked	Not locked
033	Polygon M Lock	Locked	Not locked

System Service Mode

Num.	Sensor/Switch	1h	0h
035	Total CO Install	Installed	Not installed
036	Key CO Install	Installed	Not installed
037	L-Synchronization	Detected	Not detected
039	DF-Cover Open S	Open	Closed
040	DF-Original Set S	Paper detected	Not detected
041	DF-Registration S	Paper detected	Not detected
042	DF-Exit S	Paper detected	Not detected
044	DF-Reverse S	Paper detected	Not detected
045	Platen Cover S	Open	Closed
050	Fan Motor Lock (High speed)	High speed	Low speed or stop
052	Front Cover SW	Open	Closed
053	HP Sensor	Detected	Not detected
055	BK-UpperCover SW	Open	Closed
056	BK-LowerCover SW	Open	Closed

* Available Paper Feed Unit

00	None
30	1-tray paper feed unit

3.1.3 OUTPUT CHECK (SP5-804)

Conducting Output Check

CAUTION

- To prevent mechanical or electrical damage, do not keep an electrical component on for a long time.
1. Select SP5-804.
 2. Select the number (see the table below) corresponding to the component.
 3. Select "ON."
 4. To stop the operation, select "OFF."

Output Check Table

Num.	Component
001	Main M- Fwd
002	Main M- Rev
003	Quenching Lamp
004	Toner Sup CL
005	Fan M- High
006	Fan M- Low
007	Registration CL
008	By-pass Feed CL
009	Upper Feed CL
010	BK-Upper Feed CL
015	BK-Lower Feed CL
020	Duplex Inv M- Rev
021	Duplex Inv M- Fwd
024	Duplex Inv M- Hold

System Service Mode

Num.	Component
026	Polygon M
027	Polygon M/LD
028	LD
029	DF-Feed M
030	DF-Transport M
031	DF-Feed CL
034	DF-Gate SOL (Junction Gate Solenoid)
038	Fusing SOL

When checking Fan Motor High (005) or Fan Motor Low (006) note the following:

- These motors may not respond when the fusing temperature is high.
- Selecting "ON" checks that one of these motors normally operates. Selecting "OFF" turns off the motor that you have started by selecting "ON." However, this does not guarantee that the motor normally stops during normal operation.

3.1.4 PRINTER SERVICE MODE

Service Mode Table

1001	Bit Switch			
001	Bit Switch 1		0	1
	bit 0	DFU	-	-
	bit 1	DFU	-	-
	bit 2	DFU	-	-
	bit 3	No I/O Timeout	0: Disable	1: Enable
		Enables/Disables MFP I/O Timeouts. Enabled: The MFP I/O Timeout setting will have no affect. I/O Timeouts will never occur.		
	bit 4	SD Card Save Mode	0: Disable	1: Enable
		Enabled: Print jobs will be saved to an SD Card in the GW SD slot (🔑 "Card Save Function" in the service tables of Field Service Manual).		
	bit 5	DFU	-	-
	bit 6	DFU	-	-
bit 7	[RPCS,PCL]: Printable area frame border	0: Disable	1: Enable	
	Enable: The machine prints all RPCS and PCL jobs with a border on the edges of the printable area.			

1001	Bit Switch			
002	Bit Switch 2		0	1
	bit 0	DFU	-	-
	bit 1	DFU	-	-
	bit 2	Applying a collate Type	Shift Collate	Normal Collate
		<p>A collation type (shift or normal) will be applied to all jobs that do not already have a 'Collate Type' configured.</p> <p> Note</p> <ul style="list-style-type: none"> If #5-0 is enabled, this Bit Switch has no effect. 		
	bit 3	[PCL5e/c,PS]: PDL Auto Switching	0: Enable	1: Disable
		<p>Disabled: The MFPs ability to change the PDL processor mid-job. Some host systems submit jobs that contain both PS and PCL5e/c. If Auto PDL switching is disabled, these jobs will not be printed properly.</p>		
	bit 4	DFU	-	-
	bit 5	DFU	-	-
bit 6	DFU	-	-	
bit 7	DFU	-	-	

1001	Bit Switch			
003	Bit Switch 3		0	1
	bit 0	DFU	-	-
	bit 1	DFU	-	-
	bit 2	[PCL5e/c]: Legacy HP compatibility	0: Disable	1: Enable
		<p>Enabled: Uses the same left margin as older HP models such as HP4000/HP8000.</p> <p>In other words, the left margin defined in the job (usually "<ESC>*r0A") will be changed to "<ESC>*r1A"</p>		
	bit 3	DFU	-	-
	bit 4	DFU	-	-
	bit 5	DFU	-	-
	bit 6	DFU	-	-
bit 7	DFU	-	-	

1001	Bit Switch			
004	Bit Switch 4 DFU		-	-

1001	Bit Switch			
005	Bit Switch 5		0	1
	bit 0	DFU	-	-
	bit 1	Multiple copies if a paper size or type mismatch occurs	Disabled (single copy)	Enabled (multiple)
<p>If a paper size or type mismatch occurs during the printing of multiple copies, only a single copy is output by default. Using this BitSw, the device can be configured to print all copies even if a paper mismatch occurs.</p>				

bit 2	DFU	-	-
bit 3	[PS] PS Criteria	Pattern3	Pattern1
	<p>Change the number of PS criterion used by the PS interpreter to determine whether a job is PS data or not.</p> <p>Pattern3: includes most PS commands.</p> <p>Pattern1: A small number of PS tags and headers</p>		
bit 4	Increase max number of the stored jobs to 1000 jobs.	Disable (100)	Enable (1000)
	<p>Enabled: Changes the maximum number of jobs that can be stored on the HDD via Job Type settings to 1000. The default is 100.</p>		
bit 5	DFU	-	-
bit 6	Method for determining the image rotation for the edge to bring on	Disable	Enable
	<p>Enabled: The image rotation will be performed as they were in the specifications of older models for the binding of pages of mixed orientation jobs. The old models are below:</p> <p>-PCL-: Pre-04A models</p>		
bit 7	Letterhead mode printing	Disable	Enable (Duplex)
	<p>Routes all pages through the duplex unit. If this is disabled, simplex pages or the last page of an odd-paged duplex job, are not routed through the duplex unit. This could result in problems with letterhead / pre-printed pages.</p>		

1001 Bit Switch			
006	Bit Switch 6	0	1
bit 7	Timing of the PjL Status ReadBack (JOB END) when printing multiple collated copies.	0: Disabled	1: Enable
<p>This bitsw determines the timing of the PjL USTATUS JOB END sent when multiple collated copies are being printed.</p> <p>0 (default): JOB END is sent by the device to the client after the first copy has completed printing. This causes the page counter to be incremented after the first copy and then again at the end of the job.</p> <p>1: JOB END is sent by the device to the client after the last copy has finished printing. This causes the page counter to be incremented at the end of each job.</p>			

Appendix:
SP Mode
Tables

1001 Bit Switch			
007	Bit Switch 7 DFU	-	-

1001 Bit Switch			
008	Bit Switch 8 bit 0~8 DFU	-	-

1003	Clear Setting	Not used
1004	Print Summary	Prints the service summary sheet (An error log is printed in addition to the configuration page).
1005	Display Version	Displays the version of the controller firmware.
1006	Sample/Locked print	0: Link with Doc., 1: On Enables and disables the document server. When you select "0" the document server is enabled or disables in accordance with copy service mode SP5-967. When you select "1" the document server is enabled regardless of service mode SP5-967.

SP Modes Related to Printer Controller

The following SP modes are located in the copier SP mode. Refer to section 5.1 of the main unit service manual.

SP No.	Description	Function and Setting
5801	Memory All Clear	Resets data for process control and all software counters, and returns all modes and adjustments to their defaults values.  Section "Memory Clear" in this chapter for details.
5907	Plug & Play	Selects the brand name and the production name for Windows Plug & Play. This information is stored in NVRAM.
7832	Detailed Display of Self-Diagnostics	Displays the controller self-diagnostic result.

3.1.5 SCANNER PROGRAM MODE TABLE

Service Table Key

Notation	What it means
[range / default / step]	Example: [-9 to +9 / +3.0 / 0.1 mm step]. The setting can be adjusted in the range ± 9 , value reset to +3.0 after an NVRAM reset, and the value can be changed in 0.1 mm steps with each key press.
<i>italics</i>	Comments added for your reference.
*	This value is stored in NVRAM. After a RAM reset, the default value (factory setting) is restored.
DFU	Denotes "Design or Factory Use". Do not change this value.

SP1	Mode Number		Function and [Setting]
1001*	5	Scan NV Version	Displays the scanner NV version. This shows as following: Function name _ Model name _ Version
1004*	1	Compression Type	Selects the compression type for binary picture processing. [1: MH , 2: MR, 3: MMR]
1005*	1	Erase Margin	Creates an erase margin for all edges of the scanned image. If the machine has scanned the edge of the original, create a margin. [0 to 5 / 0mm / 1mm step]
1009*	1	Remote Scan disable	Enables or disables the network TWAIN scanner function. 0 : enable, 1: disable

System Service Mode

1012	1	User Info Release	Clears or does not clear a user information after a job. [0 or 1 / 1 / -] 0: Not clear, 1: Clear
1013	1	Multi Media Func	Display or not display a "Scan To Multi Media" function. [0 or 1 / 1 / -] 0: OFF, 1: ON

SP	Number/Name	Function and [Setting]
2021	Compression level (grayscale or full color)	
	These SP codes set the compression ratio for the grayscale or full color processing mode that can be selected with the notch settings on the operation panel. Range: 5 (lowest ratio) ↔ 95 (highest ratio)	
1	Comp1: 5-95 (Middle I-Qual)	[5 to 95 / 20 /1/step]
2	Comp2: 5-95 (High I-Qual)	[5 to 95 / 40 /1/step]
3	Comp3: 5-95 (Low I-Qual)	[5 to 95 / 65 /1/step]

4	Comp4: 5-95 (Highest I-Qual)	[5 to 95 / 80 /1/step]	
5	Comp5: 5-95 (Lowest I-Qual)	[5 to 95 / 95 /1/step]	

For the settings of the image quality, see the copier SP-mode table.

APPENDIX:

FAX TROUBLESHOOTING GUIDE

REVISION HISTORY		
Page	Date	Added/Updated/New
		None

4. APPENDIX: FAX TROUBLESHOOTING GUIDE

4.1 FAX ERROR CODES

- If an error code occurs, retry the communication. If the same problem occurs, try to fix the problem as suggested below. Note that some error codes appear only in the error code display and on the service report.

Code	Meaning	Suggested Cause/Action
0-00	DIS/NSF not detected within 40 s of Start being pressed	<ul style="list-style-type: none"> ▪ Check the line connection. ▪ The machine at the other end may be incompatible. ▪ Replace the NCU or FCU. ▪ Check for DIS/NSF with an oscilloscope. ▪ If the rx signal is weak, there may be a bad line.
0-01	DCN received unexpectedly	<ul style="list-style-type: none"> ▪ The other party is out of paper or has a jammed printer. ▪ The other party pressed Stop during communication.
0-03	Incompatible modem at the other end	The other terminal is incompatible.
0-04	CFR or FTT not received after modem training	<ul style="list-style-type: none"> ▪ Check the line connection. ▪ Try changing the tx level and/or cable equalizer settings. ▪ Replace the FCU. ▪ The other terminal may be faulty; try sending to another machine. ▪ If the rx signal is weak or defective, there may be a bad line. <p>Cross reference</p> <p>Tx level - NCU Parameter 01 (PSTN) Cable equalizer - G3 Switch 07 (PSTN) Dedicated Tx parameters in Service Program</p>

Fax Error Codes

Code	Meaning	Suggested Cause/Action
		Mode
0-05	Modem training fails even G3 shifts down to 2400 bps.	<ul style="list-style-type: none"> ▪ Check the line connection. ▪ Try adjusting the tx level and/or cable equalizer. ▪ Replace the FCU. ▪ Check for line problems. <p>Cross reference See error code 0-04.</p>
0-06	The other terminal did not reply to DCS	<ul style="list-style-type: none"> ▪ Check the line connection. ▪ Try adjusting the tx level and/or cable equalizer settings. ▪ Replace the NCU or FCU. ▪ The other end may be defective or incompatible; try sending to another machine. ▪ Check for line problems. <p>Cross reference See error code 0-04.</p>
0-07	No post-message response from the other end after a page was sent	<ul style="list-style-type: none"> ▪ Check the line connection. ▪ Replace the NCU or FCU. ▪ The other end may have jammed or run out of paper. ▪ The other end user may have disconnected the call. ▪ Check for a bad line. ▪ The other end may be defective; try sending to another machine.

0-08	The other end sent RTN or PIN after receiving a page, because there were too many errors	<ul style="list-style-type: none"> ▪ Check the line connection. ▪ Replace the NCU or FCU. ▪ The other end may have jammed, or run out of paper or memory space. ▪ Try adjusting the tx level and/or cable equalizer settings. ▪ The other end may have a defective modem/NCU/FCU; try sending to another machine. ▪ Check for line problems and noise. <p>Cross reference</p> <ul style="list-style-type: none"> ▪ Tx level - NCU Parameter 01 (PSTN) ▪ Cable equalizer - G3 Switch 07 (PSTN) ▪ Dedicated Tx parameters in Service Program Mode
0-14	Non-standard post message response code received	<ul style="list-style-type: none"> ▪ Incompatible or defective remote terminal; try sending to another machine. ▪ Noisy line: resend. ▪ Try adjusting the tx level and/or cable equalizer settings. ▪ Replace the NCU or FCU. <p>Cross reference</p> <p>See error code 0-08.</p>
0-15	The other terminal is not capable of specific functions.	<p>The other terminal is not capable of accepting the following functions, or the other terminal's memory is full.</p> <ul style="list-style-type: none"> ▪ Confidential rx ▪ Transfer function ▪ SEP/SUB/PWD/SID

Fax Error Codes

0-16	CFR or FTT not detected after modem training in confidential or transfer mode	<ul style="list-style-type: none"> ▪ Check the line connection. ▪ Replace the NCU or FCU. ▪ Try adjusting the tx level and/or cable equalizer settings. ▪ The other end may have disconnected, or it may be defective; try calling another machine. ▪ If the rx signal level is too low, there may be a line problem. <p>Cross reference See error code 0-08.</p>
0-20	Facsimile data not received within 6 s of retraining	<ul style="list-style-type: none"> ▪ Check the line connection. ▪ Replace the NCU or FCU. ▪ Check for line problems. ▪ Try calling another fax machine. ▪ Try adjusting the reconstruction time for the first line and/or rx cable equalizer setting. <p>Cross reference Reconstruction time - G3 Switch 0A, bit 6 Rx cable equalizer - G3 Switch 07 (PSTN)</p>
0-21	EOL signal (end-of-line) from the other end not received within 5 s of the previous EOL signal	<ul style="list-style-type: none"> ▪ Check the connections between the FCU, NCU, & line. ▪ Check for line noise or other line problems. ▪ Replace the NCU or FCU. ▪ The remote machine may be defective or may have disconnected. <p>Cross reference Maximum interval between EOLs and between ECM frames - G3 Bit Switch 0A, bit 4</p>

0-22	The signal from the other end was interrupted for more than the acceptable modem carrier drop time (default: 200 ms)	<ul style="list-style-type: none"> ▪ Check the line connection. ▪ Replace the NCU or FCU. ▪ Defective remote terminal. ▪ Check for line noise or other line problems. ▪ Try adjusting the acceptable modem carrier drop time. <p>Cross reference Acceptable modem carrier drop time - G3 Switch 0A, bits 0 and 1</p>
0-23	Too many errors during reception	<ul style="list-style-type: none"> ▪ Check the line connection. ▪ Replace the NCU or FCU. ▪ Defective remote terminal. ▪ Check for line noise or other line problems. ▪ Try asking the other end to adjust their tx level. ▪ Try adjusting the rx cable equalizer setting and/or rx error criteria. <p>Cross reference Rx cable equalizer - G3 Switch 07 (PSTN) Rx error criteria - Communication Switch 02, bits 0 and 1</p>
0-30	The other terminal did not reply to NSS(A) in AI short protocol mode	<ul style="list-style-type: none"> ▪ Check the line connection. ▪ Try adjusting the tx level and/or cable equalizer settings. ▪ The other terminal may not be compatible. <p>Cross reference Dedicated tx parameters - Section 4</p>
0-32	The other terminal sent a DCS, which contained functions that the receiving machine cannot handle.	<ul style="list-style-type: none"> ▪ Check the protocol dump list. ▪ Ask the other party to contact the manufacturer.

Fax Error Codes

0-33	The data reception (not ECM) is not completed within 10 minutes.	<ul style="list-style-type: none"> ▪ Check the line connection. ▪ The other terminal may have a defective modem/NCU/FCU.
0-52	Polarity changed during communication	<ul style="list-style-type: none"> ▪ Check the line connection. ▪ Retry communication.
0-55	FCU does not detect the SG3.	<ul style="list-style-type: none"> ▪ FCU firmware or board defective. ▪ SG3 firmware or board defective.
0-56	The stored message data exceeds the capacity of the mailbox in the SG3.	<ul style="list-style-type: none"> ▪ SG3 firmware or board defective.
0-70	The communication mode specified in CM/JM was not available (V.8 calling and called terminal)	<ul style="list-style-type: none"> ▪ The other terminal did not have a compatible communication mode (e.g., the other terminal was a V.34 data modem and not a fax modem.) ▪ A polling tx file was not ready at the other terminal when polling rx was initiated from the calling terminal.
0-74	The calling terminal fell back to T.30 mode, because it could not detect ANSam after sending CI.	<ul style="list-style-type: none"> ▪ The calling terminal could not detect ANSam due to noise, etc. ▪ ANSam was too short to detect. ▪ Check the line connection and condition. ▪ Try making a call to another V.8/V.34 fax.
0-75	The called terminal fell back to T.30 mode, because it could not detect a CM in response to ANSam (ANSam timeout).	<ul style="list-style-type: none"> ▪ The terminal could not detect ANSam. ▪ Check the line connection and condition. ▪ Try receiving a call from another V.8/V.34 fax.

0-76	The calling terminal fell back to T.30 mode, because it could not detect a JM in response to CM (CM timeout).	<ul style="list-style-type: none"> ▪ The called terminal could not detect a CM due to noise, etc. ▪ Check the line connection and condition. ▪ Try making a call to another V.8/V.34 fax.
0-77	The called terminal fell back to T.30 mode, because it could not detect a CJ in response to JM (JM timeout).	<ul style="list-style-type: none"> ▪ The calling terminal could not detect a JM due to noise, etc. ▪ A network that has narrow bandwidth cannot pass JM to the other end. ▪ Check the line connection and condition. ▪ Try receiving a call from another V.8/V.34 fax.
0-79	The called terminal detected CI while waiting for a V.21 signal.	<ul style="list-style-type: none"> ▪ Check for line noise or other line problems. ▪ If this error occurs, the called terminal falls back to T.30 mode.
0-80	The line was disconnected due to a timeout in V.34 phase 2 – line probing.	<ul style="list-style-type: none"> ▪ The guard timer expired while starting these phases. Serious noise, narrow bandwidth, or low signal level can cause these errors. <p>If these errors happen at the transmitting terminal:</p> <ul style="list-style-type: none"> ▪ Try making a call at a later time. ▪ Try using V.17 or a slower modem using dedicated tx parameters. <p>If these errors happen at the receiving terminal:</p> <ul style="list-style-type: none"> ▪ Try increasing the tx level. ▪ Try adjusting the tx cable equalizer setting. ▪ Try adjusting the rx cable equalizer setting. ▪ Try increasing the tx level. ▪ Try using V.17 or a slower modem if the same error is frequent when receiving from multiple senders.
0-81	The line was disconnected due to a timeout in V.34 phase 3 – equalizer training.	
0-82	The line was disconnected due to a timeout in the V.34 phase 4 – control channel start-up.	
0-83	The line was disconnected due to a timeout in the V.34 control channel restart sequence.	

Fax Error Codes

0-84	The line was disconnected due to abnormal signaling in V.34 phase 4 – control channel start-up.	<ul style="list-style-type: none"> ▪ The signal did not stop within 10 s. ▪ Turn off the machine, then turn it back on. ▪ If the same error is frequent, replace the FCU.
0-85	The line was disconnected due to abnormal signaling in V.34 control channel restart.	<ul style="list-style-type: none"> ▪ The signal did not stop within 10 s. ▪ Turn off the machine, then turn it back on. ▪ If the same error is frequent, replace the FCU.
0-86	The line was disconnected because the other terminal requested a data rate using MPh that was not available in the currently selected symbol rate.	<ul style="list-style-type: none"> ▪ The other terminal was incompatible. ▪ Ask the other party to contact the manufacturer.
0-87	The control channel started after an unsuccessful primary channel.	<ul style="list-style-type: none"> ▪ The receiving terminal restarted the control channel because data reception in the primary channel was not successful. ▪ This does not result in an error communication.
0-88	The line was disconnected because PPR was transmitted/received 9 (default) times within the same ECM frame.	<ul style="list-style-type: none"> ▪ Try using a lower data rate at the start. ▪ Try adjusting the cable equalizer setting.
2-11	Only one V.21 connection flag was received	<ul style="list-style-type: none"> ▪ Replace the FCU.
2-12	Modem clock irregularity	<ul style="list-style-type: none"> ▪ Replace the FCU.
2-13	Modem initialization error	<ul style="list-style-type: none"> ▪ Turn off the machine, then turn it back on. ▪ Update the modem ROM. ▪ Replace the FCU.

2-23	JBIG compression or reconstruction error	<ul style="list-style-type: none"> ▪ Turn off the machine, then turn it back on.
2-24	JBIG ASIC error	<ul style="list-style-type: none"> ▪ Turn off the machine, then turn it back on.
2-25	JBIG data reconstruction error (BIH error)	<ul style="list-style-type: none"> ▪ JBIG data error ▪ Check the sender's JBIG function. ▪ Update the MBU ROM.
2-26	JBIG data reconstruction error (Float marker error)	
2-27	JBIG data reconstruction error (End marker error)	
2-28	JBIG data reconstruction error (Timeout)	
2-29	JBIG trailing edge maker error	<ul style="list-style-type: none"> ▪ FCU defective ▪ Check the destination device.
2-50	The machine resets itself for a fatal FCU system error	<ul style="list-style-type: none"> ▪ If this is frequent, update the ROM, or replace the FCU.
2-51	The machine resets itself because of a fatal communication error	<ul style="list-style-type: none"> ▪ If this is frequent, update the ROM, or replace the FCU.
2-53	Snd msg() in the manual task is an error because the mailbox for the operation task is full.	<ul style="list-style-type: none"> ▪ The user did the same operation many times, and this gave too much load to the machine.
4-01	Line current was cut	<ul style="list-style-type: none"> ▪ Check the line connector. ▪ Check for line problems. ▪ Replace the FCU or the NCU.

Fax Error Codes

4-10	Communication failed because of an ID Code mismatch (Closed Network) or Tel. No./CSI mismatch (Protection against Wrong Connections)	<ul style="list-style-type: none"> ▪ Get the ID Codes the same and/or the CSIs programmed correctly, then resend. ▪ The machine at the other end may be defective.
5-10	DCR timer expired	<ul style="list-style-type: none"> ▪ Replace the FCU.
5-20	Storage impossible because of a lack of memory	<ul style="list-style-type: none"> ▪ Temporary memory shortage. ▪ Test the SAF memory.
5-21	Memory overflow	
5-23	Print data error when printing a substitute rx or confidential rx message	<ul style="list-style-type: none"> ▪ Test the SAF memory. ▪ Ask the other end to resend the message.
5-25	SAF file access error	<ul style="list-style-type: none"> ▪ Replace an SD card or HDD. ▪ Replace the FCU.
6-00	G3 ECM - T1 time out during reception of facsimile data	<ul style="list-style-type: none"> ▪ Try adjusting the rx cable equalizer. ▪ Replace the FCU.
6-01	G3 ECM - no V.21 signal was received	
6-02	G3 ECM - EOR was received	
6-04	G3 ECM - RTC not detected	<ul style="list-style-type: none"> ▪ Check the line connection. ▪ Check for a bad line or defective remote terminal. ▪ Replace the FCU.

6-05	G3 ECM - facsimile data frame not received within 18 s of CFR, but there was no line fail	<ul style="list-style-type: none"> ▪ Check the line connection. ▪ Check for a bad line or defective remote terminal. ▪ Replace the FCU. ▪ Try adjusting the rx cable equalizer <p>Cross reference</p> <ul style="list-style-type: none"> ▪ Rx cable equalizer - G3 Switch 07 (PSTN)
6-06	G3 ECM - coding/decoding error	<ul style="list-style-type: none"> ▪ Defective FCU. ▪ The other terminal may be defective.
6-08	G3 ECM - PIP/PIN received in reply to PPS.NULL	<ul style="list-style-type: none"> ▪ The other end pressed Stop during communication. ▪ The other terminal may be defective.
6-09	G3 ECM - ERR received	<ul style="list-style-type: none"> ▪ Check for a noisy line. ▪ Adjust the tx levels of the communicating machines. ▪ See code 6-05.
6-10	G3 ECM - error frames still received at the other end after all communication attempts at 2400 bps	<ul style="list-style-type: none"> ▪ Check for line noise. ▪ Adjust the tx level (use NCU parameter 01 or the dedicated tx parameter for that address). ▪ Check the line connection. ▪ Defective remote terminal.
6-21	V.21 flag detected during high speed modem communication	<ul style="list-style-type: none"> ▪ The other terminal may be defective or incompatible.
6-22	The machine resets the sequence because of an abnormal handshake in the V.34 control channel	<ul style="list-style-type: none"> ▪ Check for line noise. ▪ If the same error occurs frequently, replace the FCU. ▪ Defective remote terminal.
6-99	V.21 signal not stopped within 6 s	<ul style="list-style-type: none"> ▪ Replace the FCU.

Fax Error Codes

13-17	SIP user name registration error	<ul style="list-style-type: none"> ▪ Double registration of the SIP user name. ▪ Capacity for user-name registration in the SIP server is not sufficient.
13-18	SIP server access error	<ul style="list-style-type: none"> ▪ Incorrect initial setting for the SIP server. ▪ Defective SIP server.
13-24	SIP authentication password error	<ul style="list-style-type: none"> ▪ The input password for the authentication does not match the password registered in the SIP server.
14-00	SMTP Send Error	<ul style="list-style-type: none"> ▪ Error occurred during sending to the SMTP server. Occurs for any error other than 14-01 to 16. For example, the mail address of the system administrator is not registered.
14-01	SMTP Connection Failed	<ul style="list-style-type: none"> ▪ Failed to connect to the SMTP server (timeout) because the server could not be found. ▪ The PC is not ready to transfer files. ▪ SMTP server not functioning correctly. ▪ The DNS IP address is not registered. ▪ Network not operating correctly. ▪ Destination folder selection not correct.
14-02	No Service by SMTP Service (421)	<ul style="list-style-type: none"> ▪ SMTP server operating incorrectly, or the destination for direct SMTP sending is not correct. ▪ Contact the system administrator and check that the SMTP server has the correct settings and operates correctly. ▪ Contact the system administrator for direct SMTP sending and check the sending destination.

14-03	Access to SMTP Server Denied (450)	<ul style="list-style-type: none"> ▪ Failed to access the SMTP server because the access is denied. ▪ SMTP server operating incorrectly. Contact the system administrator to determine if there is a problem with the SMTP server and to check that the SMTP server settings are correct. ▪ Folder send destination is incorrect. Contact the system administrator to determine that the SMTP server settings and path to the server are correct. ▪ Device settings incorrect. Confirm that the user name and password settings are correct. ▪ Direct SMTP destination incorrect. Contact the system administrator to determine if there is a problem at the destination at that the settings at the destination are correct.
14-04	Access to SMTP Server Denied (550)	<ul style="list-style-type: none"> ▪ SMTP server operating incorrectly ▪ Direct SMTP sending not operating correctly
14-05	SMTP Server HDD Full (452)	<ul style="list-style-type: none"> ▪ Failed to access the SMTP server because the HDD on the server is full. ▪ Insufficient free space on the HDD of the SMTP server. Contact the system administrator and check the amount of space remaining on the SMTP server HDD. ▪ Insufficient free space on the HDD where the destination folder is located. Contact the system administrator and check the amount of space remaining on the HDD where the target folder is located. ▪ Insufficient free space on the HDD at the target destination for SMTP direct sending. Contact the system administrator and check the amount of space remaining on the target HDD.

Fax Error Codes

14-06	User Not Found on SMTP Server (551)	<ul style="list-style-type: none"> ▪ The designated user does not exist. ▪ The designated user does not exist on the SMTP server. ▪ The designated address is not for use with direct SMTP sending.
14-07	Data Send to SMTP Server Failed (4XX)	<ul style="list-style-type: none"> ▪ Failed to access the SMTP server because the transmission failed. ▪ PC not operating correctly. ▪ SMTP server operating incorrectly ▪ Network not operating correctly. ▪ Destination folder setting incorrect. ▪ Direct SMTP sending not operating correctly.
14-08	Data Send to SMTP Server Failed (5XX)	<ul style="list-style-type: none"> ▪ Failed to access the SMTP server because the transmission failed. ▪ SMTP server operating incorrectly ▪ Destination folder setting incorrect. ▪ Direct SMTP sending not operating correctly. ▪ Software application error.
14-09	Authorization Failed for Sending to SMTP Server	<ul style="list-style-type: none"> ▪ POP-Before-SMTP or SMTP authorization failed. ▪ Incorrect setting for file transfer
14-10	Addresses Exceeded	<ul style="list-style-type: none"> ▪ Number of broadcast addresses exceeded the limit for the SMTP server.
14-11	Buffer Full	<ul style="list-style-type: none"> ▪ The send buffer is full so the transmission could not be completed. Buffer is full due to using Scan-to-Email while the buffer is being used send mail at the same time.
14-12	Data Size Too Large	<ul style="list-style-type: none"> ▪ Transmission was cancelled because the detected size of the file was too large.
14-13	Send Cancelled	<ul style="list-style-type: none"> ▪ Processing is interrupted because the user pressed Stop.

14-14	Security Locked File Error	<ul style="list-style-type: none"> Update the software because of the defective software.
14-15	Mail Data Error	<ul style="list-style-type: none"> The transmitting a mail is interrupted via DCS due to the incorrect data. Update the software because of the defective software.
14-16	Maximum Division Number Error	<ul style="list-style-type: none"> When a mail is divided for the mail transmission and the division number of a mail are more than the specified number, the mail transmission is interrupted. Update the software because of the defective software.
14-17	Incorrect Ticket	<ul style="list-style-type: none"> Update the software because of the defective software.
14-18	Access to MCS File Error	<ul style="list-style-type: none"> The access to MCS file is denied due to the no permission of access. Update the software because of the defective software.
14-30	MCS File Creation Failed	<p>Failed to create the MCS file because:</p> <ul style="list-style-type: none"> The number of files created with other applications on the Document Server has exceeded the limit. HDD is full or not operating correctly. Software error.
14-31	UFS File Creation Failed	<p>UFS file could not be created:</p> <ul style="list-style-type: none"> Not enough space in UFS area to handle both Scan-to-Email and IFAX transmission. HDD full or not operating correctly. Software error.

Fax Error Codes

14-32	Cancelled the Mail Due to Error Detected by NFAX	<ul style="list-style-type: none"> Error detected with NFAX and send was cancelled due to a software error.
14-33	No Mail Address For the Machine	<ul style="list-style-type: none"> Neither the mail address of the machine nor the mail address of the network administrator is registered.
14-34	Address designated in the domain for SMTP sending does not exist	<ul style="list-style-type: none"> Operational error in normal mail sending or direct SMTP sending. Check the address selected in the address book for SMTP sending. Check the domain selection.
14-50	Mail Job Task Error	<p>Due to an FCU mail job task error, the send was cancelled:</p> <ul style="list-style-type: none"> Address book was being edited during creation of the notification mail. Software error.
14-51	UCS Destination Download Error	<p>Not even one return notification can be downloaded:</p> <ul style="list-style-type: none"> The address book was being edited. The number for the specified destination does not exist (it was deleted or edited after the job was created).
14-60	Send Cancel Failed	<ul style="list-style-type: none"> The cancel operation by the user failed to cancel the send operation.
14-61	Notification Mail Send Failed for All Destinations	<ul style="list-style-type: none"> All addresses for return notification mail failed.
14-62	Transmission Error due to the existence of zero line page	<ul style="list-style-type: none"> When the 0 line page exists in received pages with G3 communication, the transmission is interrupted.

15-01	POP3/IMAP4 Server Not Registered	<ul style="list-style-type: none"> At startup, the system detected that the IP address of the POP3/IMAP4 server has not been registered in the machine.
15-02	POP3/IMAP4 Mail Account Information Not Registered	<ul style="list-style-type: none"> The POP3/IMAP4 mail account has not been registered.
15-03	Mail Address Not Registered	<ul style="list-style-type: none"> The mail address has not been registered.
15-10	DCS Mail Receive Error	<ul style="list-style-type: none"> Error other than 15-11 to 15-18.
15-11	Connection Error	<p>The DNS or POP3/IMAP4 server could not be found:</p> <ul style="list-style-type: none"> The IP address for DNS or POP3/IMAP4 server is not stored in the machine. The DNS IP address is not registered. Network not operating correctly.
15-12	Authorization Error	<p>POP3/IMAP4 send authorization failed:</p> <ul style="list-style-type: none"> Incorrect IFAX user name or password. Access was attempted by another device, such as the PC. POP3/IMAP4 settings incorrect.
15-13	Receive Buffer Full	<ul style="list-style-type: none"> Occurs only during manual reception. Transmission cannot be received due to insufficient buffer space. The buffer is being used for mail send or Scan-to-Email.
15-14	Mail Header Format Error	<ul style="list-style-type: none"> The mail header is not standard format. For example, the Date line description is incorrect.
15-15	Mail Divide Error	<ul style="list-style-type: none"> The e-mail is not in standard format. There is no boundary between parts of the e-mail, including the header.
15-16	Mail Size Receive Error	<ul style="list-style-type: none"> The mail cannot be received because it is too large.

Fax Error Codes

15-17	Receive Timeout	<ul style="list-style-type: none"> May occur during manual receiving only because the network is not operating correctly.
15-18	Incomplete Mail Received	<ul style="list-style-type: none"> Only one portion of the mail was received.
15-31	Final Destination for Transfer Request Reception Format Error	<ul style="list-style-type: none"> The format of the final destination for the transfer request was incorrect.
15-39	Send/Delivery Destination Error	<p>The transmission cannot be delivered to the final destination:</p> <ul style="list-style-type: none"> Destination file format is incorrect. Could not create the destination for the file transmission.
15-41	SMTP Receive Error	<ul style="list-style-type: none"> Reception rejected because the transaction exceeded the limit for the "Auth. E-mail RX" setting.
15-42	Off Ramp Gateway Error	<ul style="list-style-type: none"> The delivery destination address was specified with Off Ramp Gateway OFF.
15-43	Address Format Error	<ul style="list-style-type: none"> Format error in the address of the Off Ramp Gateway.
15-44	Addresses Over	<ul style="list-style-type: none"> The number of addresses for the Off Ramp Gateway exceeded the limit of 30.
15-61	Attachment File Format Error	<ul style="list-style-type: none"> The attached file is not TIFF format.

15-62	TIFF File Compatibility Error	<p>Could not receive transmission due to:</p> <ul style="list-style-type: none"> ▪ Resolution error ▪ Image of resolution greater than 200 dpi without extended memory. ▪ Resolution is not supported. ▪ Page size error ▪ The page size was larger than A3. ▪ Compression error ▪ File was compressed with other than MH, MR, or MMR.
15-63	TIFF Parameter Error	<p>The TIFF file sent as the attachment could not be received because the TIFF header is incorrect:</p> <ul style="list-style-type: none"> ▪ The TIFF file attachment is a type not supported. ▪ The TIFF file attachment is corrupted. ▪ Software error.
15-64	TIFF Decompression Error	<p>The file received as an attachment caused the TIFF decompression error:</p> <ul style="list-style-type: none"> ▪ The TIFF format of the attachment is corrupted. ▪ Software error.
15-71	Not Binary Image Data	<ul style="list-style-type: none"> ▪ The file could not be received because the attachment was not binary image data.
15-73	MDN Status Error	<ul style="list-style-type: none"> ▪ Could not find the Disposition line in the header of the Return Receipt, or there is a problem with the firmware.
15-74	MDN Message ID Error	<ul style="list-style-type: none"> ▪ Could not find the Original Message ID line in the header of the Return Receipt, or there is a problem with the firmware.

Fax Error Codes

15-80	Mail Job Task Read Error	<ul style="list-style-type: none"> Could not receive the transmission because the destination buffer is full and the destination could not be created (this error may occur when receiving a transfer request or a request for notification of reception).
15-81	Repeated Destination Registration Error	<ul style="list-style-type: none"> Could not repeat receive the transmission because the destination buffer is full and the destination could not be created (this error may occur when receiving a transfer request or a request for notification of reception).
15-91	Send Registration Error	<p>Could not receive the file for transfer to the final destination:</p> <ul style="list-style-type: none"> The format of the final destination or the transfer destination is incorrect. Destinations are full so the final and transfer destinations could not be created.
15-92	Memory Overflow	<ul style="list-style-type: none"> Transmission could not be received because memory overflowed during the transaction.
15-93	Memory Access Error	<ul style="list-style-type: none"> Transaction could not complete due to a malfunction of SAF memory.
15-94	Incorrect ID Code	<ul style="list-style-type: none"> The machine rejected an incoming e-mail for transfer request, because the ID code in the incoming e-mail did not match the ID code registered in the machine.
15-95	Transfer Station Function	<ul style="list-style-type: none"> The machine rejected an incoming e-mail for transfer because the transfer function was unavailable.

22-00	Original length exceeded the maximum scan length	<ul style="list-style-type: none"> ▪ Divide the original into more than one page. ▪ Check the resolution used for scanning. Lower the scan resolution if possible. ▪ Add optional page memory.
22-01	Memory overflow while receiving	<ul style="list-style-type: none"> ▪ Wait for the files in the queue to be sent. ▪ Delete unnecessary files from memory. ▪ Transfer the substitute reception files to another fax machine, if the machine's printer is busy or out of order. ▪ Add an optional SAF memory card or hard disk.
22-02	Tx or rx job stalled due to line disconnection at the other end	<ul style="list-style-type: none"> ▪ The job started normally but did not finish normally; data may or may not have been received fully. ▪ Restart the machine.
22-04	The machine cannot store received data in the SAF	<ul style="list-style-type: none"> ▪ Update the ROM ▪ Replace the FCU.
22-05	No G3 parameter confirmation answer	<ul style="list-style-type: none"> ▪ Defective FCU board or firmware.
23-00	Data read timeout during construction	<ul style="list-style-type: none"> ▪ Restart the machine. ▪ Replace the FCU.
25-00	The machine software resets itself after a fatal transmission error occurred	<ul style="list-style-type: none"> ▪ Update the ROM ▪ Replace the FCU.
F0-xx	V.34 modem error	<ul style="list-style-type: none"> ▪ Replace the FCU.
F6-xx	SG3 modem error	<ul style="list-style-type: none"> ▪ Update the SG3 modem ROM. ▪ Replace the SG3 board. ▪ Check for line noise or other line problems. ▪ Try communicating another V.8/V.34 fax.

4.2 IFAX TROUBLESHOOTING

- Use the following procedures to determine whether the machine or another part of the network is causing the problem.

Communication Route	Item	Action [Remarks]
General LAN	1. Connection with the LAN	<ul style="list-style-type: none"> Check that the LAN cable is connected to the machine. Check that the LEDs on the hub are lit.
	2. LAN activity	<ul style="list-style-type: none"> Check that other devices connected to the LAN can communicate through the LAN.
Between IFAX and PC	1. Network settings on the PC	<ul style="list-style-type: none"> Check the network settings on the PC. [Is the IP address registered in the TCP/IP properties in the network setup correct?] Check the IP address with the administrator of the network.]
	2. Check that PC can connect with the machine	<ul style="list-style-type: none"> Use the “ping” command on the PC to contact the machine. [At the MS-DOS prompt, type ping then the IP address of the machine, then press Enter.]
	3. LAN settings in the machine	<ul style="list-style-type: none"> Check the LAN parameters Check if there is an IP address conflict with other PCs. [Use the “Network” function in the User Tools. If there is an IP address conflict, inform the administrator.]

Communication Route	Item	Action [Remarks]
Between machine and e-mail server	LAN settings in the machine	<ul style="list-style-type: none"> ▪ Check the LAN parameters ▪ Check if there is an IP address conflict with other PCs. [Use the “Network” function in the User Tools. If there is an IP address conflict, inform the administrator.]
Between machine and e-mail server	1. E-mail account on the server	<ul style="list-style-type: none"> ▪ Make sure that the machine can log into the e-mail server. ▪ Check that the account and password stored in the server are the same as in the machine. [Ask the administrator to check.]
	2. E-mail server	<ul style="list-style-type: none"> ▪ Make sure that the client devices which have an account in the server can send/receive e-mail. [Ask the administrator to check. Send a test e-mail with the machine’s own number as the destination. The machine receives the returned e-mail if the communication is performed successfully.]
Between e-mail server and internet	1. E-mail account on the Server	<ul style="list-style-type: none"> ▪ Make sure that the PC can log into the e-mail server. ▪ Check that the account and password stored in the server are the same as in the machine. [Ask the administrator to check.]
	2. E-mail server	<ul style="list-style-type: none"> ▪ Make sure that the client devices which have an account in the server can send/receive e-mail. [Ask the administrator to check. Send a test e-mail with the machine’s own

Communication Route	Item	Action [Remarks]
		number as the destination. The machine receives the returned e-mail if the communication is performed successfully.]
	3. Destination e-mail address	<ul style="list-style-type: none"> ▪ Make sure that the e-mail address is actually used. ▪ Check that the e-mail address contains no incorrect characters such as spaces.
Between e-mail server and internet	Router settings	<ul style="list-style-type: none"> ▪ Use the “ping” command to contact the router. ▪ Check that other devices connected to the router can send data over the router. [Ask the administrator of the server to check.]
Between e-mail server and internet	Error message by e-mail from the network of the destination.	<ul style="list-style-type: none"> ▪ Check whether e-mail can be sent to another address on the same network, using the application e-mail software. ▪ Check the error e-mail message. [Inform the administrator of the LAN.]

4.3 IP-FAX TROUBLESHOOTING

4.3.1 IP-FAX TRANSMISSION

Cannot send by IP Address/Host Name

Check Point		Action
1	LAN cable connected?	Check the LAN cable connection.
2	Specified IP address/host name correct?	Check the IP address/host name.
3	Firewall/NAT is installed?	Cannot breach the firewall. Send by using another method (Fax, Internet Fax)
4	Transmission sent manually?	Manual sending not supported.
5	IP address of local machine registered?	Register the IP address.
6	Remote terminal port number setting other than 1720?	Send by specifying the port number.
7	Specified port number correct?	Confirm the port number of the remote fax.
8	DNS server registered when host name specified?	Contact the network administrator.
9	Remote fax a T.38 terminal?	Check whether the remote fax is a T38 terminal.
10	Remote fax switched off or busy?	Check that the remote fax is switched on.

11	Network bandwidth too narrow?	Request the network administrator to increase the bandwidth.
		Raise the delay level. IPFAX SW 01 Bit 0 to 3
		IP-Fax bandwidth is the same as the DCS speed. Set IP-Fax SW00 Bit 6 to 1.
12	Remote fax cancelled transmission?	Check whether the remote fax cancelled the transmission.

Cannot send via VoIP Gateway

Check Point		Action
1	LAN cable connected?	Check the LAN cable connection.
2	VoIP Gateway T.38 standard?	Contact the network administrator.
3	VoIP Gateway installed correctly?	Contact the network administrator.
4	VoIP Gateway power switched on?	Contact the network administrator.
5	Is the IP address/host name of the specified Gateway correct?	Check the IP address/host name.
6	Number of the specified fax correct?	Check the remote fax number.
7	Firewall/NAT is installed?	Cannot breach the firewall. Send by using another method (Fax, Internet Fax)
8	Transmission sent manually?	Manual sending not supported.
9	IP address of local fax registered?	Register the IP address.
10	DNS registered when host name specified?	Contact the network administrator.
11	Remote fax a G3 fax?	Check that the remote fax is a G3 fax.
12	G3 fax is connected to VoIP gateway?	Check that G3 fax is connected.
13	Remote G3 fax turned on?	Check that G3 fax is switched on.
14	Network bandwidth too narrow?	Request the network administrator to increase the bandwidth.
		Raise the network delay level. IPFAX SW 01 Bit 0 to 3
		IP-Fax bandwidth is the same as the DCS speed. Set IP-Fax SW00 Bit 6 to 1.

Cannot send by Alias Fax number.

Check Point		Action
1	LAN cable connected?	Check the LAN cable connection.
2	Number of specified Alias fax correct?	Confirm the Alias of the remote fax. Error Code: 13-14
3	Firewall/NAT installed?	Cannot breach the firewall. Send by using another method (Fax, Internet Fax)
4	Transmission sent manually?	Manual sending not supported.
5	Gatekeeper installed correctly?	Contact the network administrator.
6	Gatekeeper power switched on?	Contact the network administrator.
7	IP address/host name of Gatekeeper correct?	Check the IP address/host name.
8	DNS server registered when Gatekeeper host name specified?	Contact the network administrator.
9	Enable H.323 SW is set to on?	Check the settings. See User Parameter SW 34 Bit 0
10	IP address of local fax registered?	Register the IP address of the local fax.
11	Alias number of local fax registered?	Register the Alias number of the local fax.
12	Remote fax registered in Gatekeeper?	Contact the network administrator.
13	Remote fax a T.38 terminal?	Check whether the remote fax is a T38 terminal.
14	Remote fax switched off or busy?	Contact the network administrator.

15	Network bandwidth too narrow?	Request the system administrator to increase the bandwidth.
		Raise the delay level. IPFAX SW 01 Bit 0 to 3
		Lower the modem transmission baud rate. IPFAX SW 05
16	Remote fax cancelled transmission?	Check whether the remote fax cancelled the transmission.

4.3.2 IP-FAX RECEPTION

Cannot receive by IP Address/Host name.





Check Point		Action
1	LAN cable connected?	Check the LAN cable connection.
2	Firewall/NAT is installed?	Cannot breach the firewall. Send by using another method (Fax, Internet Fax)
3	IP address of local fax registered?	Register the IP address.
4	Port number specified at remote sender fax (if required)?	Request the sender to specify the port number.
5	Specified port number correct (if required)?	Request the sender to check the port number.
6	DNS server registered when host name specified on sender side?	<p>Contact the network administrator.</p> <p> Note</p> <ul style="list-style-type: none"> The sender machine displays this error code if the sender fax is a Ricoh model.



7	Network bandwidth too narrow?	Request the system administrator to increase the bandwidth.
		Lower the start modem reception baud rate on the receiving side. IPFAX SW06
8	Remote fax cancelled transmission?	Check whether the remote fax cancelled the transmission.

Cannot receive by VoIP Gateway.

Check Point		Action
1	LAN cable connected?	Check the LAN cable connection.
2	Firewall/NAT is installed?	Cannot breach the firewall. Request the remote fax to send by using another method (Fax, Internet Fax)
3	VoIP Gateway installed correctly?	Contact the network administrator.
4	VoIP Gateway power switched on?	Contact the network administrator.
5	IP address/host name of specified VoIP Gateway correct on sender's side?	Request the remote fax to check the IP address/host name.
6	DNS server registered when host name specified on sender side?	Contact the network administrator.
7	Network bandwidth too narrow?	Request the network administrator to increase the bandwidth.
8	G3 fax connected?	Check that G3 fax is connected.
9	G3 fax power switched on?	Check that G3 fax is switched on.

Cannot receive by Alias Fax number.

Check Point		Action
1	LAN cable connected?	Check the LAN cable connection.
2	Firewall/NAT is installed?	Cannot the breach firewall. Request the remote fax to send by using another method (Fax, Internet Fax)
3	Gatekeeper installed correctly?	Contact the network administrator.  Note <ul style="list-style-type: none"> The sender machine displays this error code when the sender fax is a Ricoh model.
4	Power to Gatekeeper switched on?	Contact the network administrator.  Note <ul style="list-style-type: none"> The sender machine displays this error code when the sender fax is a Ricoh model.
5	IP address/host name of Gatekeeper correct on the sender's side?	Request the sender to check the IP address/host name.  Note <ul style="list-style-type: none"> The sender machine displays this error code when the sender fax is a Ricoh model.
6	DNS server registered when Gatekeeper host name specified on sender's side?	Contact the network administrator.  Note <ul style="list-style-type: none"> The sender machine displays this error code when the sender fax is a Ricoh model.

7	Enable H.323 SW is set to on?	<p>Request the sender to check the settings. User Parameter SW 34 Bit 0</p> <p> Note</p> <ul style="list-style-type: none"> ▪ Only if the remote sender fax is a Ricoh fax.
8	Local fax IP address registered?	Register the IP address.
9	Local fax Alias number registered?	Register the Alias number.
10	Network bandwidth too narrow?	Request the system administrator to increase the bandwidth.
		Lower the start modem reception baud rate on the receiving side. IPFAX SW06
11	Remote fax cancelled transmission?	Check whether the remote fax cancelled the transmission.
12	Local fax registered in Gatekeeper?	<p>Contact the network administrator.</p> <p> Note</p> <ul style="list-style-type: none"> ▪ The sender machine displays this error code when the sender fax is a Ricoh model.

APPENDIX:
FAX SERVICE PROGRAM





REVISION HISTORY		
Page	Date	Added/Updated/New
		None

5. APPENDIX: FAX SERVICE PROGRAM

5.1 SYSTEM SERVICE MODE

5.1.1 SP1-XXX (BIT SWITCHES)

 "Bit Switches"

1	Mode No.	Function
101	System Switch	
	001 – 032	00 – 1F Change the bit switches for system settings for the fax option ( "Bit Switches")
102	Ifax Switch	
	001 – 016	00 – 0F Change the bit switches for internet fax settings for the fax option ( "Bit Switches")
103	Printer Switch	
	001 – 016	00 – 0F Change the bit switches for printer settings for the fax option ( "Bit Switches")
104	Communication Switch	
	001 – 032	00 – 1F Change the bit switches for communication settings for the fax option ( "Bit Switches")
105	G3-1 Switch	
	001 – 016	00 – 0F Change the bit switches for the protocol settings of the standard G3 board ( "Bit Switches")

111	IP fax Switch		
	001 – 016	00 – 0F	Change the bit switches for optional IP fax parameters (☛ "Bit Switches")

5.1.2 SP2-XXX (RAM DATA)

2	Mode No.		Function
101	RAM Read/Write		
	001		Change RAM data for the fax board directly. (☛ "Service RAM Addresses")
102	Memory Dump		
	001	G3-1 Memory Dump	Print out RAM data for the fax board. (☛ "Service RAM Addresses")
103	G3-1 NCU Parameters		
	001 – 023	CC, 01 – 22	NCU parameter settings for the standard G3 board. (☛ "NCU Parameters")

5.1.3 SP3-XXX (TEL LINE SETTINGS)

3	Mode No.		Function
101	Service Station		
	001	Fax Number	Enter the fax number of the service station.
102	Serial Number		
	000		Enter the fax unit's serial number.
103	PSTN-1 Port Settings		
	001	Select Line	Select the line type setting for the G3-1 line. If the machine is installed on a PABX line, select "PABX", "PABX(GND)" or "PABX(FLASH)".
	002	PSTN Access Number	Enter the PSTN access number for the G3-1 line.
	003	Memory Lock Disabled	If the customer does not want to receive transmissions using Memory Lock on this line, turn this SP on.
107	IPFAX Port Settings		
	001	H323 Port	-
	002	SIP Port	-
	003	RAS Port	-
	004	Gatekeeper port	-
	005	T.38 Port	-
	006	SIP Server Port	-
	007	IPFAX Protocol Priority	Select "H323" or "SIP".

201	FAX SW		
	001 – 032	00 – 1F	-

5.1.4 SP4-XXX (ROM VERSIONS)

4	Mode No.		Function
101	002 – 007	FCU ROM Version	Displays the FCU ROM version.
102	002 – 065	Error Codes	Displays the latest 64 fax error codes.
103	002 – 004	G3-1 ROM Version	Displays the G3-1 modem version.

5.1.5 SP5-XXX (INITIALIZING)

5	Mode No.	Function
101	Initialize SRAM	
	001	Initializes the bit switches and user parameters, user data in the SRAM, files in the SAF memory, and clock.
102	Erase All Files	
	001	Erases all files stored in the SAF memory.
103	Reset Bit Switches	
	001	Resets the bit switches and user parameters.
104	Factory setting	
	001	Resets the bit switches and user parameters, user data in the SRAM and files in the SAF memory.
105	Reset All Bit Switches	
	001	Initializes all the current bit switch settings.
106	Reset Security Bit Switches	
	001	Initializes only the security bit switches. If you select automatic output/display for the user parameter switches, the security settings are initialized.

5.1.6 SP6-XXX (REPORTS)

6	Mode No.		Function
101	System Parameter List		
	001	-	Touch the "ON" button to print the system parameter list.
102	Service Monitor		
	001	-	Touch the "ON" button to print the service monitor report.
103	G3 Protocol Dump List		
	001	G3-1 (All Communications)	Prints the protocol dump list of all communications for the G3-1 line.
	002	G3-1 (1 Communication)	Prints the protocol dump list of the last communication for the G3-1 line.
105	All Files print out		
	001	-	Prints out all the user files in the SAF memory, including confidential messages.  <ul style="list-style-type: none"> ▪ Do not use this function, unless the customer is having trouble printing confidential messages or recovering files stored using the memory lock feature.
106	Journal Print out		
	001	All Journals	The machine prints all the communication records on the report.
	002	Specified Date	The machine prints all communication records after the specified date.

107	Log List Print out		
	001	All log files	These log print out functions are for designer use only.
	002	Printer	
	003	SC/TRAP Stored	
	004	Decompression	
	005	Scanner	
	006	JOB/SAF	
	007	Reconstruction	
	008	JBIG	
	009	G3CCU	
	010	Fax Job	
	011	CCU	
	012	Scanner Condition	
108	IP Protocol Dump List		
	001	All Communications	Prints the protocol dump list of all communications for the IP fax line.
	002	1 Communication	Prints the protocol dump list of the last communication for the IP fax line.

5.1.7 SP7-XXX (TEST MODES)

These are the test modes for PTT approval.

7	Function
101	G3-1 Modem Tests
102	G3-1 DTMF Tests
103	Ringer Test
104	G3-1 V34 (S2400baud)
105	G3-1 V34 (S2800baud)
106	G3-1 V34 (S3000baud)
107	G3-1 V34 (S3200baud)
108	G3-1 V34 (S3429baud)
109	Message Test

5.2 BIT SWITCHES

WARNING

- Do not adjust a bit switch or use a setting that is described as “Not used”, as this may cause the machine to malfunction or to operate in a manner that is not accepted by local regulations. Such bits are for use only in other areas, such as Japan.

Note

- Default settings for bit switches are not listed in this manual. Refer to the System Parameter List printed by the machine.

5.2.1 SYSTEM SWITCHES

System Switch 00 [SP No. 1-101-001]		
No	FUNCTION	COMMENTS
0	Dedicated transmission parameter programming 0: Disabled, 1: Enabled	Set this bit to 1 before changing any dedicated transmission parameters. Reset this bit to 0 after programming dedicated transmission parameters.
1	Not used	Do not change
2	Technical data printout on the Journal 0: Disabled 1: Enabled	1: Instead of the personal name, the following data are listed on the Journal for each G3 communication.
e.g. 0000 (1) // 32 (2) V34 (3) // 288 (4) // 264 (5) // L0100 (6) 03 (7) 04 (8) (1): EQM value (Line quality data). A larger number means more errors. (2): Symbol rate (V.34 only) (3): Final modem type used (4): Starting data rate (for example, 288 means 28.8 kbps) (5): Final data rate (6): Rx revel (refer to the note after this table for how to read the rx level) (7): Total number of error lines that occurred during non-ECM reception. (8): Total number of burst error lines that occurred during non-ECM reception.  Note		

Bit Switches

	<ul style="list-style-type: none"> EQM and rx level are fixed at “FFFF” in tx mode. The seventh and eighth numbers are fixed at “00” for transmission records and ECM reception records.
	<p>Rx level calculation</p> <p>Example: 0000 // 32 V34 // 288/264 // L 01 00 03 04</p> <p>The four-digit hexadecimal value (N) after “L” indicates the rx level.</p> <p>The high byte is given first, followed by the low byte. Divide the decimal value of N by -16 to get the rx level.</p> <p>In the above example, the decimal value of N (= 0100 [H]) is 256.</p> <p>So, the actual rx level is $256/-16 = -16$ dB</p>
3	<p>Not used</p> <p>Do not change this setting.</p>
4	<p>Line error mark print</p> <p>0: OFF, 1: ON (print)</p> <p>When “1” is selected, a line error mark is printed on the printout if a line error occurs during reception.</p>
5	<p>G3/G4 communication parameter display</p> <p>0: Disabled</p> <p>1: Enabled</p> <p>This is a fault-finding aid. The LCD shows the key parameters (see below). This is normally disabled because it cancels the CSI display for the user. Be sure to reset this bit to 0 after testing.</p>
6	<p>Protocol dump list output after each communication</p> <p>0: Off</p> <p>1: On</p> <p>This is only used for communication troubleshooting. It shows the content of the transmitted facsimile protocol signals. Always reset this bit to 0 after finishing testing. If system switch 09 bit 6 is at “1”, the list is only printed if there was an error during the communication.</p>
7	<p>Not used</p> <p>Do not change the setting.</p>

System Switch 01 - Not used (Do not change the factory settings.)

System Switch 02 [SP No. 1-101-003]		
No	FUNCTION	COMMENTS
0-1	Not used	Do not change these settings.
2	Force after transmission stall 0: Off 1: On	With this setting on, the machine resets itself automatically if a transmission stalls and fails to complete the job.
3-5	Not used	Do not change these settings.
6-7	Memory read/write by RDS Bit 7: 0, Bit 6: 0 Always disabled Bit 7: 0, Bit 6: 1 User selectable Bit 7: 1, Bit 6: 0 User selectable Bit 7: 1, Bit 6: 1 Always enabled	(0,0): All RDS systems are always locked out. (0,1), (1,0): Normally, RDS systems are locked out, but the user can temporarily switch RDS on to allow RDS operations to take place. RDS will automatically be locked out again after a certain time, which is stored in System Switch 03. Note that if an RDS operation takes place, RDS will not switch off until this time limit has expired. (1,1): At any time, an RDS system can access the machine.

System Switch 03 [SP No. 1-101-004]		
No	FUNCTION	COMMENTS
0-7	Length of time that RDS is temporarily switched on when bits 6 and 7 of System Switch 02 are set to "User selectable"	00 - 99 hours (BCD). This setting is only valid if bits 6 and 7 of System Switch 02 are set to "User selectable". The default setting is 24 hours.

System Switch 04 [SP No. 1-101-005]		
No	FUNCTION	COMMENTS
0-2	Not used	Do not change these settings.
3	Printing dedicated tx parameters on Quick/Speed Dial Lists 0: Disabled 1: Enabled	1: Each Quick/Speed dial number on the list is printed with the dedicated tx parameters (10 bytes each). The first 10 bytes of data are the programmed dedicated tx parameters; 34 bytes of data are printed (the other 24 bytes have no use for service technicians).
4-7	Not used	Do not change these settings.

System Switch 05 - Not used (Do not change the factory settings.)

System Switch 06 - Not used (Do not change the factory settings.)

System Switch 07 - Not used (Do not change the factory settings.)

System Switch 08 - Not used (Do not change the factory settings.)

System Switch 09 [SP No. 1-101-010]		
No	FUNCTION	COMMENTS
0	Not used	Do not change these settings.
1	Inclusion of communications on the Journal when no image data was exchanged. 0: Disabled 1: Enabled	0: Communications that reached phase C (message tx/rx) of the T.30 protocol are listed on the Journal. 1: Communications that reached phase A (call setup) of T.30 protocol are listed on the Journal. This will include telephone calls.
2	Automatic error report printout 0: Disabled 1: Enabled	0: Error reports will not be printed. 1: Error reports will be printed automatically after failed communications.

3	Printing of the error code on the error report 0: No 1: Yes	1: Error codes are printed on the error reports.
4	Not used	Do not change this setting.
5	Power failure report 0: Disabled 1: Enabled	1: A power failure report will be automatically printed after the power is switched on if a fax message disappeared from the memory when the power was turned off last.
6	Conditions for printing the protocol dump list 0: Print for all communications 1: Print only when there is a communication error	This switch becomes effective only when system switch 00 bit 6 is set to 1. 1: Set this bit to 1 when you wish to print a protocol dump list only for communications with errors.
7	Priority given to various types of remote terminal ID when printing reports 0: RTI > CSI > Dial label > Tel. Number 1: Dial label > Tel. number > RTI > CSI	This bit determines which set of priorities the machine uses when listing remote terminal names on reports. Dial Label: The name stored, by the user, for the Quick/Speed Dial number.

System Switch 0A [SP No. 1-101-011]		
No	FUNCTION	COMMENTS
0-3	Not used	Do not change these settings.
4	Dialing on the ten-key pad when the external telephone is off-hook 0: Disabled 1: Enabled	0: Prevents dialing from the ten-key pad while the external telephone is off-hook. Use this setting when the external telephone is not by the machine, or if a wireless telephone is connected as an external telephone. 1: The user can dial on the machine's ten-key pad when the handset is off-hook.
5	On hook dial 0: Disabled 1: Enabled	0: On hook dial is disabled.
6-7	Not used	Do not change the factory settings.

System Switch 0B - Not used (Do not change the factory settings.)

System Switch 0C - Not used (Do not change the factory settings.)

System Switch 0D - Not used (Do not change the factory settings.)

System Switch 0E [SP No. 1-101-015]		
No	FUNCTION	COMMENTS
0-1	Not used	Do not change the settings.
2	Not used	This machine does not have the capture function.
3	Action when the external handset goes off-hook 0: Manual tx and rx operation 1: Memory tx and rx operation (the display remains the same)	0: Manual tx and rx are possible while the external handset is off-hook. However, memory tx is not possible. 1: The display stays in standby mode even when the external handset is used, so that other people can use the machine for memory tx operation. Note that manual tx and rx are not possible with

		this setting.
4-7	Not used	Do not change these settings.

System Switch 0F [SP No. 1-101-016]			
No	FUNCTION	COMMENTS	
0-7	Country/area code for functional settings (Hex)	<p>This country/area code determines the factory settings of bit switches and RAM addresses. However, it has no effect on the NCU parameter settings and communication parameter RAM addresses.</p> <p>Cross reference NCU country code: SP No. 2-103-001 for G3-1</p>	
	00: France		11: USA
	01: Germany		12: Asia
	02: UK		13: Japan
	03: Italy		14: Hong Kong
	04: Austria		15: South Africa
	05: Belgium		16: Australia
	06: Denmark		17: New Zealand
	07: Finland		18: Singapore
	08: Ireland		19: Malaysia
	09: Norway		1A: China
	0A: Sweden		1B: Taiwan
	0B: Switz.		1C: Korea
	0C: Portugal		20: Turkey
	0D: Holland		21: Greece
	0E: Spain		22: Hungary
0F: Israel	23: Czech		
10: ---	24: Poland		

System Switch 10 [SP No. 1-101-017]		
No	FUNCTION	COMMENTS
0-7	Threshold memory level for parallel memory transmission	Threshold = N x 128 KB + 256 KB N can be between 00 - FF(H) Default setting: 02(H) = 512 KB

System Switch 11 [SP No. 1-101-018]		
No	FUNCTION	COMMENTS
0	TTI printing position 0: Superimposed on the page data 1: Printed before the data leading edge	Change this bit to 1 if the TTI overprints information that the customer considers to be important (G3 transmissions).
1	Not used	Japan Only
2-7	Not used	Do not change the factory settings.

System Switch 12 [SP No. 1-101-019]		
No	FUNCTION	COMMENTS
0-7	TTI printing position in the main scan direction	TTI: 08 to 92 (BCD) mm Input even numbers only. This setting determines the print start position for the TTI from the left edge of the paper. If the TTI is moved too far to the right, it may overwrite the file number which is on the top right of the page. On an A4 page, if the TTI is moved over by more than 50 mm, it may overwrite the page number.

System Switch 13 - Not used (do not change these settings)
System Switch 14 - Not used (do not change these settings)

System Switch 15 [SP No. 1-101-022]		
No	FUNCTION	COMMENTS
0	Not used	Do not change the settings.
1	Going into the Energy Saver mode automatically 0: Enabled 1: Disabled	1: The machine will restart from the Energy Saver mode quickly, because the +5V power supply is active even in the Energy Saver mode.
2-3	Not used	Do not change these settings.
4-5	Interval for preventing the machine from entering Energy Saver mode if there is a pending transmission file. Bit 5: 0, Bit 4: 0 1 min Bit 5: 0, Bit 4: 1 30 min Bit 5: 1, Bit 4: 0 1 hour Bit 5: 1, Bit 4: 1 24 hours	If there is a file waiting for transmission, the machine does not go to Energy Saver mode during the selected period. After transmitting the file, if there is no file waiting for transmission, the machine goes to the Energy Saver mode.
6-7	Not used	Do not change

System Switch 16 [SP No. 1-101-023]		
No	FUNCTION	COMMENTS
0	Parallel Broadcasting 0: Disabled 1: Enabled	1: The machine sends messages simultaneously using all available ports during broadcasting.
1-7	Not used	Do not change these settings.

System Switch 17 - Not used (do not change these settings)

System Switch 18 - Not used (do not change these settings)

System Switch 19 [SP No. 1-101-026]

No	FUNCTION	COMMENTS
0-6	Not used	Do not change the settings.
7	Special Original mode 0: Disabled 1: Enabled	1: If the customer frequently wishes to transmit a form or letterhead which has a colored or printed background, change this bit to "1". "Original 1" and "Original 2" can be selected in addition to the "Text", "Text/Photo" and "Photo" modes.

System Switch 1A - Not used (do not change these settings)

System Switch 1B [SP No. 1-101-028]

In this switch setting, there is a limitation. Do not select the same image quality in two modes.

e.g) these setting combination is not allowed:

[Bit1: 0, Bit 0: 1 = **Text**] [Bit3: 0, Bit 2:0 = Photo/ Diffusion]

[Bit 6: 0, Bit 5: 0, Bit 4: 0 = **Text**]

No.	FUNCTION	COMMENTS
0-1	Image Quality in Text mode Bit 1: 0, Bit 0: 0 = Text/ Sharp Bit 1: 0, Bit 0: 1 = Text	This setting determines the desirable scanning image quality when the text mode is selected with the operation panel.
2-3	Image Quality in Photo mode Bit 3: 0, Bit 2: 0 = Photo/ Diffusion Bit 3: 0, Bit 2: 1 = Photo/ Dithering	This setting determines the desirable scanning image quality when the photo mode is selected with the operation panel.

4-6	Image Quality in Special Original mode			This setting determines the desirable scanning image quality when the special original mode is selected with the operation panel.	
	Bit 6	Bit 5	Bit 4	Mode	
	0	0	0	Text	
	0	0	1	Text/ Sharp	
	0	1	0	Photo/ Diffusion	
	0	1	1	Photo/ Dithering	
	1	0	0	Dropout color	
	1	0	1	-	
7	Not used			Do not change these settings.	

System Switch 1C - Not used (do not change these settings)

System Switch 1D [SP No. 1-101-030]

No	FUNCTION	COMMENTS
0	RTI/CSI/CPS code display 0: Enable 1: Disable	0: RTI, CSI, CPS codes are displayed on the top line of the LCD panel during communication. 1: Codes are switched off (no display)
1	Not used	Do not change this setting.
2	Destination telephone number display limitation 0: OFF, 1: ON	When "1" is selected, the destination telephone number display is limited and redial is disabled.
3	Operation selection without PIN code registered 0: Transmission interrupted 1: No interrupted transmission	0: When "0" is selected without PIN code registration, transmission is interrupted and an alert message shows on the LCD.

4-7	Not used	Do not change these settings.
-----	-----------------	-------------------------------

System Switch 1E [SP No. 1-101-031]		
No	FUNCTION	COMMENTS
0	Communication after the Journal data storage area has become full 0: Impossible 1: Possible	0: When this switch is on and the journal history becomes full, the next report prints. If the journal history is not deleted, the next transmission cannot be received. This prevents overwriting communication records before the machine can print them. 1: If the buffer memory of the communication records for the Journal is full, fax communications are still possible. But the machine will overwrite the oldest communication records. Note: This setting is effective only when Automatic Journal printout is enabled but the machine cannot print the report (e.g., no paper).
1	Action when the SAF memory has become full during scanning 0: The current page is erased. 1: The entire file is erased.	0: If the SAF memory becomes full during scanning, the successfully scanned pages are transmitted. 1: If the SAF memory becomes full during scanning, the file is erased and no pages are transmitted. This bit switch is ignored for parallel memory transmission.
2	RTI/CSI display priority 0: RTI 1: CSI	This bit determines which identifier, RTI or CSI, is displayed on the LCD while the machine is communicating in G3 non-standard mode.
3	File No. printing 0: Enabled 1: Disabled	1: File numbers are not printed on any reports.

4	<p>Action when authorized reception is enabled but authorized RTIs/CSIs are not yet programmed</p> <p>0: All fax reception is disabled 1: Faxes can be received if the sender has an RTI or CSI</p>	<p>If authorized reception is enabled but the user has stored no acceptable sender RTIs or CSIs, the machine will not be able to receive any fax messages.</p> <p>If the customer wishes to receive messages from any sender that includes an RTI or CSI, and to block messages from senders that do not include an RTI or CSI, change this bit to "1", then enable Authorized Reception.</p> <p>Otherwise, keep this bit at "0 (default setting)".</p>
5-7	Not used	Do not change the settings

System Switch 1F [SP No. 1-101-032]		
No	FUNCTION	COMMENTS
0	Not used	Do not change the settings.
1	<p>Report printout after an original jam during SAF storage or if the SAF memory fills up</p> <p>0: Enabled 1: Disabled</p>	<p>0: When an original jams, or the SAF memory overflows during scanning, a report will be printed.</p> <p>Change this bit to "1" if the customer does not want to have a report in these cases.</p> <p>Memory tx – Memory storage report Parallel memory tx – Transmission result report</p>
2	Not used	Do not change the settings.
3	<p>Received fax print start timing (G3 reception)</p> <p>0: After receiving each page 1: After receiving all pages</p>	<p>0: The machine prints each page immediately after the machine receives it.</p> <p>1: The machine prints the complete message after the machine receives all the pages in the memory.</p>
4-6	Not used	Do not change the factory settings.

7	Action when a fax SC has occurred 0: Automatic reset 1: Fax unit stops	0: When the fax unit detects a fax SC code other than SC1201 and SC1207, the fax unit automatically resets itself. 1: When the fax unit detects any fax SC code, the fax unit stops. Cross Reference Fax SC codes - See "Troubleshooting"
---	--	--

5.2.2 I-FAX SWITCHES

I-fax Switch 00 - Not used (do not change the settings) [SP No. 1-102-001]

I-fax Switch 01 [SP No. 1-102-002]

No	FUNCTION	COMMENTS
	Original Line Resolution of TX Attachment File	These settings set the maximum resolution of the original that the destination can receive.
0	200x100 Standard	0: Not selected 1: Selected If more than one of these three bits is set to "1", the higher resolution has priority. For example, if both Bit 0 and Bit 2 are set to "1" then the resolution is set for "Bit 2 200 x 400."
1	200x200 Detail	
2	200x400 Fine	
3	300 x 300 Reserve	
4	400 x 400 Super Fine	
5	600 x 600 Reserve	
6	Reserve	

	mm/inch
7	<p>This setting selects mm/inch conversion for mail transmission.</p> <p>0: Off (No conversion), 1: On (Conversion)</p> <p>When on (set to “1”), the machine converts millimeters to inches for sending mail.</p> <p>There is no switch for converting inches to millimeters.</p> <p>Unlike G3 fax transmissions which can negotiate between sender and receiver to determine the setting, mail cannot negotiate between terminals; the mm/inch selection is determined by the sender fax.</p> <p>When this switch is Off (0):</p> <p>Images scanned in inches are sent in inches.</p> <p>Images scanned in mm are sent in mm.</p> <p>Images received in inches are transmitted in inches.</p> <p>Images received in mm are transmitted in mm.</p> <p>When this switch is On (1):</p> <p>Images scanned in inches are sent in inches.</p> <p>Images scanned in mm are converted to inches.</p> <p>Images received in inches are transmitted in inches.</p> <p>Images received in mm are converted to inches.</p>

I-fax Switch 02 [SP No. 1-102-003]		
No	FUNCTION	COMMENTS
0	RX Text Mail Header Processing	
		<p>This setting determines whether the header information is printed with text e-mails when they are received.</p> <p>0: Prints only text mail. 1: Prints mail header information attached to text mail.</p> <p>When a text mail is received with this switch On (1), the "From" address and "Subject" address are printed as header information.</p> <p>When a mail with only binary data is received (a TIFF-F file, for example), this setting is ignored and no header is printed.</p>
1	Output from Attached Document at E-mail TX Error	
		<p>This setting determines whether only the first page or all pages of an e-mail attachment are printed at the sending station when a transmission error occurs.</p> <p>This allows the customer to see which documents have not reached their intended destinations if sent to the wrong e-mail addresses, for example.</p> <p>0: Prints 1st page only. 1: Prints all pages.</p>
2-3	Text String for Return Receipt	
		<p>This setting determines the text string output for the Return Receipt that confirms the transmission was received normally at the destination.</p>
		<p>00: "Dispatched" Sends from PC mail a request for a Return Receipt. Receives the Return Receipt with "dispatched" in the 2nd part: Disposition: Automatic-action/MDN-send automatically; dispatched The "dispatched" string is included in the Subject string.</p> <p>01: "Displayed" Sends from PC mail a request for a Return Receipt. Receives the Return Receipt with "displayed" in the 2nd part: Disposition: Automatic-action/MDN-send automatically; displayed The "displayed" string is included in the Subject string.</p> <p>10: Reserved</p>

	<p>11: Reserved</p> <p>A mail requesting a Return Receipt sent from an IFAX with this switch set to “00” (for “dispatched”) received by Microsoft Outlook 2000 may cause an error. If any setting other than “displayed” (01) causes a problem, change the setting to “01” to enable normal sending of the Return Receipt.</p>
4	<p>Media accept feature</p> <p>This setting adds or does not add the media accept feature to the answer mail to confirm a reception.</p> <p>0: Does not add the media accept feature to the answer mail 1: Adds the media accept feature to the answer mail.</p> <p>Use this bit switch if a problem occurs when the machine receives an answer mail, which contains the media accept feature field.</p>
	<p>Not Used</p>
7	<p>Image Resolution of RX Text Mail</p> <p>This setting determines the image resolution of the received mail.</p> <p>0: 200 x 200 1: 400 x 400</p> <p>The “1” setting requires installation of the Function Upgrade Card in order to have enough SAF (Store and Forward) memory to receive images at 400 x 400 resolution.</p>
	<p>Not Used</p>

I-fax Switch 03 - Not used (do not change the settings) [SP No. 1-102-004]

I-fax Switch 04 [SP No. 1-102-005]		
No	FUNCTION	COMMENTS
0	Subject for Delivery TX/Memory Transfer	<p>This setting determines whether the RTI/CSI registered on this machine or the RTI/CSI of the originator is used in the subject lines of transferred documents.</p> <p>0: Puts the RTI/CSI of the originator in the Subject line. If this is used, either the RTI or CSI is used. Only one of these can be received for use in the subject line.</p> <p>1: Puts the RTI/CSI registered on this machine in the Subject line.</p> <p>When this switch is used to transfer and deliver mail to a PC, the information in the Subject line that indicates where the transmission originated can be used to determine automatically the destination folder for each e-mail.</p>
1	Subject corresponding to mail post database	<p>0: Standard subject</p> <p>1: Mail post database subject</p> <p>The standard subject is replaced by the mail post database subject in the following three cases:</p> <ol style="list-style-type: none"> 1) When the service technician sets the service (software) switch. 2) When memory sending, delivery specified by F code or SMTP reception is done. 3) With relay broadcasting (1st stage without the Schmidt 4 function). <p> Note</p> <ul style="list-style-type: none"> ▪ This switch does not apply for condition 3) when the RX system is set up for memory sending, delivery by F-code, sending with SMTP RX and when operators are using FOL (to prevent problems when receiving transmissions).
2-7	Not Used	

I-fax Switch 05 [SP No. 1-102-006]		
No	FUNCTION	COMMENTS
0	Mail Addresses of SMTP Broadcast Recipients	
	<p>Determines whether the e-mail addresses of the destinations that receive transmissions broadcasted using SMTP protocol are recorded in the Journal.</p> <p>For example: "1st destination + Total number of destinations: 9" in the Journal indicates a broadcast to 9 destinations.</p> <p>0: Not recorded 1: Recorded</p>	
1	I-Fax Automatic Re-dial Setting 0: OFF 1: ON	Determines whether the I-fax automatically redials when an error occurs.
2-7	Not used	

I-fax Switch 06 - Not used (do not change the settings) [SP No. 1-102-007]

I-fax Switch 07 - Not used (do not change the settings) [SP No. 1-102-008]

I-fax Switch 08 [SP No. 1-102-009]		
No	FUNCTION	COMMENTS
0-7	Memory Threshold for POP Mail Reception	
	<p>This setting determines the amount of SAF (Store and Forward) memory. (SAF stores fax messages to send later for transmission to more than one location, and also holds incoming messages if they cannot be printed.) When the amount of SAF memory available falls below this setting, mail can no longer be received; received mail is then stored on the mail server.</p> <p>00-FF (0 to 1024 KB: HEX)</p> <p> Note</p> <ul style="list-style-type: none"> ▪ The hexadecimal number you enter is multiplied by 4 KB to determine the amount of memory. 	

I-fax Switch 09 [SP No. 1-102-010]		
No	FUNCTION	COMMENTS
0-3	Not used	Do not change the settings
4-7	Restrict TX Retries	<p>This setting determines the number of retries when connection and transmission fails due to errors.</p> <p>01-F (1-15 Hex)</p>

I-fax Switch 0A - Not used (do not change the settings) [SP No. 1-102-011]
I-fax Switch 0B - Not used (do not change the settings) [SP No. 1-102-012]
I-fax Switch 0C - Not used (do not change the settings) [SP No. 1-102-013]
I-fax Switch 0D - Not used (do not change the settings) [SP No. 1-102-014]
I-fax Switch 0E - Not used (do not change the settings) [SP No. 1-102-015]

I-fax Switch 0F [SP No. 1-102-016]

No	FUNCTION	COMMENTS
0	Delivery Method for SMTP RX Files	This setting determines whether files received with SMTP protocol are delivered or output immediately. 0: Off. Files received via SMTP are output immediately without delivery. 1: On. Files received via SMTP are delivered immediately to their destinations.
1-7	Not used	

5.2.3 PRINTER SWITCHES

Printer Switch 00 [SP No. 1-103-001]		
No	FUNCTION	COMMENTS
0	Select page separation marks 0: Off 1: On	<p>0: If a 2 page RX transmission is split, [*] is printed in the bottom right corner of the 1st page and only a [2] is printed in the upper right corner of the 2nd page.</p> <p>1: If a 2 page RX transmission is split into two pages, for example, [*] [2] is printed in the bottom right corner of the 1st page and only a [2] is printed in the upper right corner of the 2nd page.</p> <p> Note</p> <ul style="list-style-type: none"> This helps the user to identify pages that have been split because the size of the paper is smaller than the size of the document received. (When A5 is used to print an A4 size document, for example.)
1	Repetition of data when the received page is longer than the printer paper 0: Off 1: On	<p>1: Default. 10 mm of the trailing edge of the previous page are repeated at the top of the next page.</p> <p>0: The next page continues from where the previous page stopped without any repeated text.</p>
2	Prints the date and time on received fax messages 0: Disabled 1: Enabled	<p>This switch is only effective when user parameter 02 - bit 2 (printing the received date and time on received fax messages) is enabled.</p> <p>1: The machine prints the received and printed date and time at the bottom of each received page.</p>
3-7	Not used	Do not change the settings.

Printer Switch 01 - Not used (do not change the settings) [SP No. 1-103-002]

Printer Switch 02 [SP No. 1-103-003]

No	FUNCTION	COMMENTS
0	1st paper feed station usage for fax printing 0: Enabled 1: Disabled	0: The paper feed station can be used to print fax messages and reports. 1: The specified paper feed station will not be used for printing fax messages and reports.
1	2nd paper feed station usage for fax printing 0: Enabled 1: Disabled	<div style="border: 1px solid blue; padding: 2px; display: inline-block;"> ↓ Note </div> <ul style="list-style-type: none"> ▪ Do not disable usage for a paper feed station which has been specified by User Parameter Switch 0F (15), or which is used for the Specified Cassette Selection feature.
2-7	Not used	Do not change the settings.

Printer Switch 03 [SP No. 1-103-004]

No	FUNCTION	COMMENTS
0	Length reduction of received data 0: Disabled 1: Enabled	0: Incoming pages are printed without length reduction. (Page separation threshold: Printer Switch 03, bits 4 to 7) 1: Incoming page length is reduced when printing. (Maximum reducible length: Printer Switches 04, bits 0 to 4)
1-3	Not used	Do not change the settings

Bit Switches

4-7	<p>Page separation setting when sub scan compression is forbidden</p> <p>00-0F (0-15 mm: Hex)</p> <p>Default: 6 mm</p>	<p>Page separation threshold (with reduction disabled with switch 03-0 above).</p> <p>For example, if this setting is set to "10", and A4 is the selected paper size:</p> <p>If the received document is 10 mm or less longer than A4, then the 10 mm are cut and only 1 page prints.</p> <p>If the received document is 10 mm longer than A4, then the document is split into 2 pages.</p>
-----	--	---

Printer Switch 04 SP No. 1-103-005						
No	FUNCTION			COMMENTS		
0-4	<p>Maximum reducible length when length reduction is enabled with switch 03-0 above.</p> <p><Maximum reducible length> = <Paper length> + (N x 5mm)</p> <p>"N" is the decimal value of the binary setting of bits 0 to 4.</p>					
	Bit 4	Bit 3	Bit 2	Bit 1	Bit 0	Setting
	0	0	0	0	0	0 mm
	0	0	0	0	1	5 mm
	0	0	1	0	0	20 mm
	1	1	1	1	1	155 mm
<p>For A5 sideways and B5 sideways paper</p> <p><Maximum reducible length> = <Paper length> + 0.75 x (N x 5mm)</p>						
5-6	<p>Length of the duplicated image on the next page, when page separation has taken place.</p> <p>Bit 6: 0, Bit 5: 0 = 4 mm</p> <p>Bit 6: 1, Bit 5: 0 = 10 mm</p> <p>Bit 6: 0, Bit 5: 1 = 15 mm</p> <p>Bit 6: 1, Bit 5: 1 = Not used</p>					

7	Not used.	Do not change the setting.
---	------------------	----------------------------

Printer Switch 05 - Not used (do not change the settings)

Printer Switch 06 [SP No. 1-103-007]

No	FUNCTION	COMMENTS
0	<p>Printing while a paper cassette is pulled out, when the Just Size Printing feature is enabled.</p> <p>0: Printing will not start 1: Printing will start if another cassette has a suitable size of paper, based on the paper size selection priority tables.</p>	<p>Cross reference</p> <p>Just size printing on/off – User switch 05, bit 5</p>
1-7	Not used.	Do not change the settings.

Printer Switch 07 [SP No. 1-103-008]

No	FUNCTION	COMMENTS
0-3	Not used.	Do not change the settings.
4	<p>List of destinations in the Communication Failure Report for broadcasting</p> <p>0: All destinations 1: Only destinations where communication failure occurred</p>	<p>1: Only destinations where communication failure occurred are printed on the Communication Failure Report.</p>
5-7	Not used.	Do not change the settings.

Printer Switch 08 - Not used (do not change the settings) [SP No. 1-103-009]
Printer Switch 09 - Not used (do not change the settings) [SP No. 1-103-010]
Printer Switch 0A - Not used (do not change the settings) [SP No. 1-103-011]
Printer Switch 0B - Not used (do not change the settings) [SP No. 1-103-012]
Printer Switch 0C - Not used (do not change the settings) [SP No. 1-103-013]
Printer Switch 0D - Not used (do not change the settings) [SP No. 1-103-014]

Printer Switch 0E [SP No. 1-103-015]		
No	FUNCTION	COMMENTS
0	Paper size selection priority 0: Width 1: Length	0: A paper size that has the same width as the received data is selected first. 1: A paper size which has enough length to print all the received lines without reduction is selected first.
1	Paper size selected for printing A4 width fax data 0: 8.5" x 11" size 1: A4 size	This switch determines which paper size is selected for printing A4 width fax data, when the machine has both A4 and 8.5" x 11" size paper.
2	Page separation 0: Enabled 1: Disabled	1: If all paper sizes in the machine require page separation to print a received fax message, the machine does not print the message (Substitute Reception is used). After a larger size of paper is set in a cassette, the machine automatically prints the fax message.
3-4	Printing the sample image on reports Bit 4: 0, Bit 3: 0 = The upper half only Bit 4: 0, Bit 3: 1 = 50% reduction in	"Same size" means the sample image is printed at 100%, even if page separation occurs. User Parameter Switch 19 (13H) bit 4 must be set to "0" to enable this switch.

	sub-scan only Bit 4: 1, Bit 3: 0 = Same size Bit 4: 1, Bit 3: 1 = Not used	Refer to Detailed Section Descriptions for more on this feature.
5-6	Not used	Do not change the settings.
7	Equalizing the reduction ratio among separated pages (Page Separation) 0: Enabled 1: Disabled	0: When page separation has taken place, all the pages are reduced with the same reduction ratio. 1: Only the last page is reduced to fit the selected paper size when page separation has taken place. Other pages are printed without reduction.

Printer Switch 0F [SP No. 1-103-016]		
No	FUNCTION	COMMENTS
0-1	Smoothing feature Bit 1: 0 Bit 0: 0 = Disabled Bit 1: 0 Bit 0: 1 = Disabled Bit 1: 1 Bit 0: 0 = Enabled Bit 1: 1 Bit 0: 1 = Not used	(0, 0) (0, 1): Disable smoothing if the machine receives halftone images from other manufacturers fax machines frequently.
2-7	Not used	Do not change the settings.

5.2.4 COMMUNICATION SWITCHES

Communication Switch 00 [SP No. 1-104-001]		
No	FUNCTION	COMMENTS
0-1	Compression modes available in receive mode Bit 1: 0 Bit 0: 0 = MH only Bit 1: 0 Bit 0: 1 = MH/MR Bit 1: 1 Bit 0: 0 = MH/MR/MMR Bit 1: 1 Bit 0: 1 = MH/MR/MMR/JBIG	These bits determine the compression capabilities to be declared in phase B (handshaking) of the T.30 protocol.
2-3	Compression modes available in transmit mode Bit 3: 0 Bit 2: 0 = MH only Bit 3: 0 Bit 2: 1 = MH/MR Bit 3: 1 Bit 2: 0 = MH/MR/MMR Bit 3: 1 Bit 2: 1 = MH/MR/MMR/JBIG	These bits determine the compression capabilities to be used in the transmission and to be declared in phase B (handshaking) of the T.30 protocol.
4	Not used	Do not change the settings.
5	JBIG compression method: Reception 0: Only basic supported 1: Basic and optional both supported	Change the setting when communication problems occur using JBIG compression.
6	JBIG compression method: Transmission 0: Basic mode priority 1: Optional mode priority	Change the setting when communication problems occur using JBIG compression.
7	Not used	Do not change the settings.

Communication Switch 01 [SP No. 1-104-002]		
No	FUNCTION	COMMENTS
0	ECM 0: Off 1: On	If this bit is set to 0, ECM is switched off for all communications. In addition, V.8 protocol and JBIG compression are switched off automatically.
1-5	Not used	Do not change the setting.
6-7	Maximum printable page length available Bit 7: 0 Bit 6: 0 = No limit Bit 7: 0 Bit 6: 1 = B4 (364 mm) Bit 7: 1 Bit 6: 0 = A4 (297 mm) Bit 7: 1 Bit 6: 1 = Not used	The setting determined by these bits is informed to the transmitting terminal in the pre-message protocol exchange (in the DIS/NSF frames).

Communication Switch 02 [SP No. 1-104-003]		
No	FUNCTION	COMMENTS
0	G3 Burst error threshold 0: Low 1: High	If there are more consecutive error lines in the received page than the threshold, the machine will send a negative response. The Low and High threshold values depend on the sub-scan resolution, and are as follows.
		100 dpi 6(L) ÷ 12(H)
		200 dpi 12(L) ÷ 24(H)
		300 dpi 18(L) ÷ 36(H)
		400 dpi 24(L) ÷ 48(H)
1	Acceptable total error line ratio 0: 5% 1: 10%	If the error line ratio for a page exceeds the acceptable ratio, RTN will be sent to the other end.

Bit Switches

2	Treatment of pages received with errors during G3 reception 0: Deleted from memory without printing 1: Printed	0: Pages received with errors are not printed.
3	Hang-up decision when a negative code (RTN or PIN) is received during G3 immediate transmission 0: No hang-up, 1: Hang-up	0: The next page will be sent even if RTN or PIN is received. 1: The machine will send DCN and hang up if it receives RTN or PIN. This bit is ignored for memory transmissions or if ECM is being used.
4-7	Not used	Do not change the settings.

Communication Switch 03 [SP No. 1-104-004]

No	FUNCTION	COMMENTS
0-7	Maximum number of page retransmissions in a G3 memory transmission	00 - FF (Hex) times. This setting is not used if ECM is switched on. Default setting - 03(H)

Communication Switch 04 - Not used (do not change the settings)

Communication Switch 05 - Not used (do not change the settings)

Communication Switch 06 - Not used (do not change the settings)

Communication Switch 07 - Not used (do not change the settings)

Communication Switch 08 - Not used (do not change the settings)

Communication Switch 09 [SP No. 1-104-010]		
No	FUNCTION	COMMENTS
0-7	I-Fax dial interval setting	Adjusts the interval of the I-fax dialing. The interval of I-fax dialing is calculated by following formula. [Interval time = specified value with this switch x 2 sec]

Communication Switch 0A [SP No. 1-104-011]		
No	FUNCTION	COMMENTS
0	Point of resumption of memory transmission upon redialing 0: From the error page 1: From page 1	0: The transmission begins from the page where transmission failed the previous time. 1: Transmission begins from the first page, using normal memory transmission.
1-7	Not used	Do not change the settings.

Communication Switch 0B – Not used (do not change the settings)		
Communication Switch 0C – Not used (do not change the settings)		

Communication Switch 0D [SP No. 1-104-014]		
No	FUNCTION	COMMENTS
0-7	The available memory threshold, below which ringing detection (and therefore reception into memory) is disabled	00 to FF (Hex), unit = 4 kbytes (e.g., 06(H) = 24 kbytes) One page is about 24 kbytes. The machine refers to this setting before each fax reception. If the amount of remaining memory is below this threshold, the machine cannot receive any fax messages. If this setting is kept at 0, the machine will detect ringing signals and go into receive mode even if there is no memory available. This will result in communication failure.

Communication Switch 0E [SP No. 1-104-015]		
No	FUNCTION	COMMENTS
0-7	Minimum interval between automatic dialing attempts	06 to FF (Hex), unit = 2 s (e.g., 06(H) = 12 s) This value is the minimum time that the machine waits before it dials the next destination.

Communication Switch 0F – Not used (do not change the settings.)

Communication Switch 10 [SP No. 1-104-017]		
No	FUNCTION	COMMENTS
0-7	Memory transmission: Maximum number of dialing attempts to the same destination	01 – FE (Hex) times

Communication Switch 11 – Not used (do not change the settings.)

Communication Switch 12 [SP No. 1-104-019]

No	FUNCTION	COMMENTS
0-7	Memory transmission: Interval between dialing attempts to the same destination	01 – FF (Hex) minutes

Communication Switch 13 – Not used (do not change the settings.)

Communication Switch 14 [SP No. 1-104-021]

No	FUNCTION	COMMENTS
0	Inch-to-mm conversion during transmission 0: Disabled 1: Enabled	0: In immediate transmission, data scanned in inch format are transmitted without conversion. In memory transmission, data stored in the SAF memory in mm format are transmitted without conversion. Note: When storing the scanned data into SAF memory, the fax unit always converts the data into mm format. 1: The machine converts the scanned data or stored data in the SAF memory to the format which was specified in the set-up protocol (DIS/NSF) before transmission.
1-5	Not used	Do not change the factory settings.

Bit Switches

6-7	<p>Available unit of resolution in which fax messages are received</p> <p>Bit 7: 0, Bit 6: 0 = mm</p> <p>Bit 7: 0, Bit 6: 1 = inch</p> <p>Bit 7: 1, Bit 6: 0 = mm and inch (default)</p> <p>Bit 7: 1, Bit 6: 1 = Not used</p>	<p>For the best performance, do not change the factory settings.</p> <p>The setting determined by these bits is informed to the transmitting terminal in the pre-message protocol exchange (in the DIS/NSF frames).</p>
-----	--	---

Communication Switch 15 – Not used (do not change the settings)

Communication Switch 16 – Not used (do not change the settings)

Communication Switch 17 – Not used (do not change the settings)

Communication Switch 18 - Not used (do not change the settings)

Communication Switch 19 - Not used (do not change the settings)

Communication Switch 1A - Not used (do not change the settings)

Communication Switch 1B [SP No. 1-104-028]

No	FUNCTION	COMMENTS
0-7	<p>Extension access code (0 to 7) to turn V.8 protocol On/Off</p> <p>0: On</p> <p>1: Off</p>	<p>If the PABX does not support V.8/V.34 protocol procedure, set this bit to “1” to disable V.8.</p> <p>Example: If “0” is the PSTN access code, set bit 0 to 1. When the machine detects “0” as the first dialed number, it automatically disables V.8 protocol. (Alternatively, if “3” is the PSTN access code, set bit 3 to 1.)</p>

Communication Switch 1C [SP No. 1-104-029]		
No	FUNCTION	COMMENTS
0-1	Extension access code (8 and 9) to turn V.8 protocol On/Off 0: On 1: Off	Refer to communication switch 1B. Example: If "8" is the PSTN access code, set bit 0 to 1. When the machine detects "8" as the first dialed number, it automatically disables V.8 protocol. (If "9" is the PSTN access code, use bit 1.)
2-7	Not used	Do not change the settings.

Communication Switch 1D - Not used (do not change the settings)

Communication Switch 1E - Not used (do not change the settings)

Communication Switch 1F - Not used (do not change the settings)

5.2.5 G3-1 SWITCHES

G3 Switch 00 [SP No. 1-105-001]		
No	FUNCTION	COMMENTS
0-1	Monitor speaker during communication (tx and rx) Bit 1: 0, Bit 0: 0 = Disabled Bit 1: 0, Bit 0: 1 = Up to Phase B Bit 1: 1, Bit 0: 0 = All the time Bit 1: 1, Bit 0: 1 = Reserved	(0, 0): The monitor speaker is disabled all through the communication. (0, 1): The monitor speaker is on up to phase B in the T.30 protocol. (1, 0): Used for testing. The monitor speaker is on all through the communication. Make sure that you reset these bits after testing.
2	Monitor speaker during memory transmission 0: Disabled 1: Enabled	1: The monitor speaker is enabled during memory transmission.
3-7	Not used	Do not change the settings.

G3 Switch 01 [SP No. 1-105-002]		
No	FUNCTION	COMMENTS
0-3	Not used	Do not change the settings.
4	DIS frame length 0: 10 bytes 1: 4 bytes	1: The bytes in the DIS frame after the 4th byte will not be transmitted (set to 1 if there are communication problems with PC-based faxes which cannot receive the extended DIS frames).
5	Not used	Do not change the setting.
6	Forbid CED/AMsam output 0: Off 1: On (Forbid output)	Do not change this setting (Default: 0: Off), unless communication problem is caused by a CED or ANSam transmission.

7	Not used	Do not change the setting.
---	-----------------	----------------------------

G3 Switch 02 [SP No. 1-105-003]		
No	FUNCTION	COMMENTS
0	G3 protocol mode used 0: Standard and non-standard 1: Standard only	Change this bit to 1 only when the other end can only communicate with machines that send T.30-standard frames only. 1: Disables NSF/NSS signals (these are used in non-standard mode communication)
1-6	Not used	Do not change the settings.
7	Short preamble 0: Disabled 1: Enabled	Refer to Appendix B in the Group 3 Facsimile Manual for details about Short Preamble.

G3 Switch 03 [SP No. 1-105-004]		
No	FUNCTION	COMMENTS
0	DIS detection number (Echo countermeasure) 0: 1 1: 2	0: The machine will hang up if it receives the same DIS frame twice. 1: Before sending DCS, the machine will wait for the second DIS which is caused by echo on the line.
1	Not Used	Do not change the settings.
2	V.8 protocol 0: Disabled 1: Enabled	0: V.8/V.34 communications will not be possible. Note: Do not set to 0 unless the line condition is always bad enough to slow down the data rate to 14.4 kbps or lower.

3	<p>ECM frame size</p> <p>0: 256 bytes</p> <p>1: 64 bytes</p>	<p>Keep this bit at "0" in most cases.</p>
4	<p>CTC transmission conditions</p> <p>0: After one PPR signal received</p> <p>1: After four PPR signals received (ITU-T standard)</p>	<p>0: When using ECM in non-standard (NSF/NSS) mode, the machine sends a CTC to drop back the modem rate after receiving a PPR, if the following condition is met in communications at 14.4, 12.0, 9.6, and 7.2 kbps.</p> $\sqrt{N_{\text{Transmit}} \leq N_{\text{Resend}}}$ <p>NTransmit- Number of transmitted frames</p> <p>NResend- Number of frames to be retransmitted</p> <p>1: When using ECM, the machine sends a CTC to drop back the modem rate after receiving four PPRs.</p> <p>PPR, CTC: These are ECM protocol signals.</p> <p>This bit is not effective in V.34 communications.</p>
5	<p>Modem rate used for the next page after receiving a negative code (RTN or PIN)</p> <p>0: No change 1: Fallback</p>	<p>1: The machine's tx modem rate will fall back before sending the next page if a negative code is received. This bit is ignored if ECM is being used.</p>
6	<p>Not Used</p>	<p>Do not change the settings</p>
7	<p>Select detection of reverse polarity in ringing</p> <p>0: Off</p> <p>1: On</p>	<p>This switch is used to prevent reverse polarity in ringing on the phone line (applied to PSTN-G3 ringing). Do not change this setting</p> <p>0: No detection ⇒ Outside Japan</p> <p>1: Detection ⇒ Inside Japan only</p>

G3 Switch 04 [SP No. 1-105-005]		
No	FUNCTION	COMMENTS
0-3	Training error detection threshold	0 - F (Hex); 0 - 15 bits If the number of error bits in the received TCF is below this threshold, the machine informs the sender that training has succeeded.
4-7	Not used	Do not change the settings.



G3 Switch 05 [SP No. 1-105-006]						
No	FUNCTION					COMMENTS
0-3	Initial Tx modem rate					<p>These bits set the initial starting modem rate for transmission.</p> <p>Use the dedicated transmission parameters if you need to change this for specific receivers.</p> <p>If a modem rate 14.4 kbps or slower is selected, V.8 protocol should be disabled manually.</p> <p>Cross reference V.8 protocol on/off - G3 switch 03, bit2</p>
	Bit 3	Bit 2	Bit 1	Bit 0	bps	
	0	0	0	1	2.4k	
	0	0	1	0	4.8k	
	0	0	1	1	7.2k	
	0	1	0	0	9.6k	
	0	1	0	1	12.0k	
	0	1	1	0	14.4k	
	0	1	1	1	16.8k	
	1	0	0	0	19.2k	
	1	0	0	1	21.6k	
	1	0	1	0	24.0k	
	1	0	1	1	26.4k	
	1	1	0	0	28.8k	
1	1	0	1	31.2k		

Bit Switches

	1	1	1	0	33.6k	
	Other settings - Not used					
4-5	Initial modem type for 9.6 k or 7.2 kbps. Bit 5: 0, Bit 4: 0 = V.29 Bit 5: 0, Bit 4: 1 = V.17 Bit 5: 1, Bit 4: 0 = V.34 Bit 5: 1, Bit 4: 1 = Reserved					These bits set the initial modem type for 9.6 and 7.2 kbps, if the initial modem rate is set at these speeds.
6-7	Not used					Do not change the settings.

G3 Switch 06 [SP No. 1-105-007]						
No	FUNCTION					COMMENTS
0-3	Initial Rx modem rate					<ul style="list-style-type: none"> ▪ These bits set the initial starting modem rate for reception. ▪ Use a lower setting if high speeds pose problems during reception. ▪ If a modem rate 14.4 kbps or slower is selected, V.8 protocol should be disabled manually. Cross reference: V.8 protocol on/off - G3 switch 03, bit2
	Bit 3	Bit 2	Bit 1	Bit 0	bps	
	0	0	0	1	2.4k	
	0	0	1	0	4.8k	
	0	0	1	1	7.2k	
	0	1	0	0	9.6k	
	0	1	0	1	12.0k	
	0	1	1	0	14.4k	
	0	1	1	1	16.8k	
	1	0	0	0	19.2k	
	1	0	0	1	21.6k	
	1	0	1	0	24.0k	
	1	0	1	1	26.4k	
	1	1	0	0	28.8k	

	1	1	0	1	31.2k	
	1	1	1	0	33.6k	
	Other settings - Not used					
4-7	Modem types available for reception					<ul style="list-style-type: none"> ▪ The setting of these bits is used to inform the transmitting terminal of the available modem type for the machine in receive mode. ▪ If V.34 is not selected, V.8 protocol must be disabled manually. <p>Cross reference: V.8 protocol on/off - G3 switch 03, bit2</p>
	Bit 7	Bit 6	Bit 5	Bit 4	Setting	
	0	0	0	1	V.27ter	
	0	0	1	0	V.27ter, V.29	
	0	0	1	1	V.27ter, V.29, V.33	
	0	1	0	0	V.27ter, V.29, V.17/V.33	
	0	1	0	1	V.27ter, V.29, V.17/V33, V.34	
Other settings - Not used						

G3 Switch 07 [SP No. 1-105-008]		
No	FUNCTION	COMMENTS
0-1	PSTN cable equalizer (tx mode: Internal) Bit 1: 0, Bit 0: 0 = None Bit 1: 0, Bit 0: 1 = Low Bit 1: 1, Bit 0: 0 = Medium Bit 1: 1, Bit 0: 1 = High	Use a higher setting if there is signal loss at higher frequencies because of the length of wire between the modem and the telephone exchange. Use the dedicated transmission parameters for specific receivers. Also, try using the cable equalizer if one or more of the following symptoms occurs. Communication error Modem rate fallback occurs frequently.  Note <ul style="list-style-type: none"> ▪ This setting is not effective in V.34 communications.
2-3	PSTN cable equalizer (rx mode: Internal) Bit 3: 0, Bit 2: 0 = None Bit 3: 0, Bit 2: 1 = Low Bit 3: 1, Bit 2: 0 = Medium Bit 3: 1, Bit 2: 1 = High	Use a higher setting if there is signal loss at higher frequencies because of the length of wire between the modem and the telephone exchange. Also, try using the cable equalizer if one or more of the following symptoms occurs. Communication error with error codes such as 0-20, 0-23, etc. Modem rate fallback occurs frequently.  Note <ul style="list-style-type: none"> ▪ This setting is not effective in V.34 communicatio
4	PSTN cable equalizer (V.8/V.17 rx mode: External) 0: Disabled 1: Enabled	Keep this bit at "1".
5	Not used	Do not change the settings.

6	Parameter selection for dial tone detection 0: Normal parameter 1: Specific parameter	0: This uses the fixed table in the ROM for dial tone detection. 1: This uses the specific parameter adjusted with SRAM (69ECBEH - 69ECDEH). Select this if the dial tone cannot be detected when the "Normal parameter: 0" is selected.
7	Not used	Do not change the settings.

G3 Switch 08 - Not used (do not change the settings)

G3 Switch 09 - Not used (do not change the settings)

G3 Switch 0A [SP No. 1-105-011]

No	FUNCTION	COMMENTS
0-1	Maximum allowable carrier drop during image data reception Bit 1: 0, Bit 0: 0 = 200 Bit 1: 0, Bit 0: 1 = 400 Bit 1: 1, Bit 0: 0 = 800 Bit 1: 1, Bit 0: 1 = Reserved	These bits set the acceptable modem carrier drop time. Try using a longer setting if error code 0-22 is frequent.
2	Select cancellation of high-speed RX if carrier signal lost while receiving 0: Off 1: On	This switch setting determines if high-speed receiving ends if the carrier signal is lost when receiving during non-ECM mode
3	Not used	Do not change the settings

4	Maximum allowable frame interval during image data reception. 0: 5 s 1: 13 s	This bit set the maximum interval between EOL (end-of-line) signals and the maximum interval between ECM frames from the other end. Try using a longer setting if error code 0-21 is frequent.
5	Not used	Do not change the settings.
6	Reconstruction time for the first line in receive mode 0: 6 s 1: 12 s	When the sending terminal is controlled by a computer, there may be a delay in receiving page data after the local machine accepts set-up data and sends CFR. This is outside the T.30 recommendation. But, if this delay occurs, set this bit to 1 to give the sending machine more time to send data. Refer to error code 0-20. ITU-T T.30 recommendation: The first line should come within 5 s of CFR.
7	Not used	Do not change the settings.

G3 Switch 0B Not used (do not change the settings).

G3 Switch 0C Not used (do not change the settings).

G3 Switch 0D Not used (do not change the settings).

G3 Switch 0E [SP No 1-105-015]

0-7	Set CNG send time interval Some machines on the receiving side may not be able to automatically switch the 3-second CNG interval.	
	High order bit	3000-2250ms: 3000-50xNms 3000 – 50 x Nms 0F (3000 ms) < N < FF (2250 ms)
	Low order bit	00-0E(3000-3700ms: 3000+50xNms 3000 – 50 x Nms 0F (3000 ms) < N < 0F (3700 ms)

G3 Switch 0F [SP No. 1-105-016]		
No	FUNCTION	COMMENTS
0	Alarm when an error occurred in Phase C or later 0: Disabled 1: Enabled	If the customer wants to hear an alarm after each error communication, change this bit to "1".
1	Alarm when the handset is off-hook at the end of communication 0: Disabled 1: Enabled	If the customer wants to hear an alarm if the handset is off-hook at the end of fax communication, change this bit to "1".
2-3	Not used	Do not change the settings.
4	Sidaa manual calibration setting 0: Off 1: On	1: manually calibrates for communication with a line, whose current change occurs such as an optical fiber line.
5-6	Not used	Do not change the settings.

5.2.6 IP FAX SWITCHES

IP Fax Switch 00 [SP No. 1-111-001]		
No.	FUNCTION	COMMENTS
0	Not used	Do not change this setting.
1	IP Fax Transport 0: TCP, 1: UDP	Selects TCP or UDP protocol for IP-Fax
2	IP Fax single port selection 0: OFF, 1: ON (enable)	Selects single data port.
3	IP Fax double ports (single data port) selection 0: OFF, 1: ON (enable)	Selects whether IP-Fax uses a double port.
4	IP Fax Gatekeeper 0: OFF, 1: ON (enable)	Enables/disables the communication via the gatekeeper for IP-Fax.
5	IP Fax T30 bit signal reverse 0: LSB first, 1: MSB first	Reverses the T30 bit signal.
6	IP Fax max bit rate setting 0: Not affected, 1: Affected	When "0" is selected, the max bit rate does not affect the value of the DIS/DCS. When "1" is selected, the max bit rate affects the value of the DIS/DCS.
7	IP Fax received telephone number confirmation 0: No confirmation, 1: Confirmation	When "0" is selected, fax data is received without checking the telephone number. When "1" is selected, fax data is received only when confirming that the telephone number from the sender matches the registered telephone number in this machine. If this confirmation fails, the line is disconnected.

IP-Fax Switch 01						
No.	FUNCTION					COMMENTS
0-3	Select IP FAX Delay Level					Raise the level by selecting a higher setting if too many transmission errors are occurring on the network. If TCP/UDP is enabled on the network, raise this setting on the T.30 machine. Increasing the delay time allows the recovery of more lost packets. If only UDP is enabled, increase the number of redundant packets. Level 1 to 2: 3 Redundant packets Level 3: 4 Redundant packets
	Bit3	Bit2	Bit1	Bit0	Setting	
	0	0	0	0	Level 0	
	0	0	0	1	Level 1	
	0	0	1	0	Level 2	
	0	0	1	1	Level 3	
4-7	IP Fax preamble wait time setting					Selects the preamble wait time. [00 to 0f] There are 16 values in this 4-bit binary switch combination. Waiting time: set value level x 100 ms Max: 0f (1500 ms) Min: 00 (No wait time) The default is "0000" (00H).

Appendix:
Fax Service
Program

IP Fax Switch 02 [SP No. 1-111-003]		
No.	FUNCTION	COMMENTS
0	IP Fax bit signal reverse setting 0: Maker code setting 1: Internal bit switch setting	When "0" is selected, the bit signal reverse method is decided by the maker code. When "1" is selected, the bit signal reverse method is decided by the internal bit switch. (When communicating between IP Fax devices, LSB first is selected.)

Bit Switches

1	<p>IP Fax transmission speed setting</p> <p>0: Modem speed</p> <p>1: No limitation</p>	<p>Selects the transmit speed for IP Fax communication.</p>
2	<p>SIP transport setting</p> <p>0: TCP</p> <p>1: UDP</p>	<p>This bit switch sets the transport that has priority for receiving IP Fax data.</p> <p>This function is activated only when the sender has both TCP and UDP.</p>
3	<p>CCM connection</p> <p>0: No CCM connection</p> <p>1: CCM connection</p>	<p>When "1" is selected, only the connection call message with H.323 or no tunneled H.245 is transmitted via CCM.</p>
4	<p>Message reception selection from non-registered SIP server</p> <p>0: Answer</p> <p>1: Not answer</p>	<p>0: This answers the INVITE message from the SIP server not registered for the machine.</p> <p>1: This does not receive the INVITE message from the SIP server not registered for the machine and send a refusal message.</p>
5	<p>ECM communication setting</p> <p>0: No limit for image compression</p> <p>1: Limit for image compression</p>	<p>0: This does not limit the type of the image compression with ECM communication.</p> <p>1: When the other end machine is Cisco, this permits the image compression other than JBIG or MMR with ECM communication.</p>
6-7	Not used	Do not change these settings.

IP Fax Switch 03 [SP No. 1-111-004]		
No.	FUNCTION	COMMENTS
0	Effective field limitation for G3 standard function information 0: OFF, 1: 4byte (DIS)	Limits the effective field for standard G3 function information.
1	Switching between G3 standard and G3 non standard 0: Enable switching 1: G3 standard only	Enables/disables switching between G3 standard and G3 non-standard.
2	Not used.	Do not change this setting.
3	ECM frame size selection at transmitting 0: 256byte, 1: 64byte	Selects the ECM frame size for sending.
4	DIS detection times for echo prevention 0: 1 time, 1: 2 times	Sets the number of times for DIS to detect echoes.
5	CTC transmission selection 0: PPRx1 1: PPRx4	When "0" is selected, the transmission condition is decided by error frame numbers. When "1" is selected, the transmission condition is based on the ITU-T method.
6	Shift down setting at receiving negative code 0: OFF, 1: ON	Selects whether to shift down when negative codes are received.
7	Not used	Do not change this setting.

IP Fax Switch 04 [SP No. 1-111-005]		
No.	FUNCTION	COMMENTS
0	TCF error threshold	Sets the TCF error threshold level. [00 to 0f] The default is "1111" (0fH).
1		
2		
3		
4-7	Not used	Do not change these settings.

IP Fax Switch 05 [SP No. 1-111-006]					
No.	FUNCTION				COMMENTS
0-3	Modem bit rate setting for transmission Sets the modem bit rate for transmission. The default is "0110" (14.4K bps).				
	Bit 4	Bit 3	Bit 2	Bit 1	
	0	0	0	1	2400 bps
	0	0	1	1	4800 bps
	0	0	1	1	7200 bps
	0	1	0	0	9600 bps
	0	1	0	1	12.0 Kbps
	0	1	1	0	14.4 Kbps
	0	1	1	1	16.8 Kbps
	1	0	0	0	19.2 Kbps
	1	0	0	1	21.6 Kbps
	1	0	1	0	24.0 Kbps
	1	0	1	1	26.4 Kbps

	1	1	0	0	28.8 Kbps
	1	1	0	1	31.2 Kbps
	1	1	1	0	33.6 Kbps
4-5	<p>Modem setting for transmission Sets the modem for transmission. The default is "00" (V29). Bit 5: 0, Bit 4: 0 = V29 Bit 5: 0, Bit 4: 1 = V17 Bit 5: 1, Bit 4: 0 = V34* Bit 5: 1, Bit 4: 1 = Not used *V34 is not supported for IP-Fax communication.</p>				
6-7	Not used		Do not change these settings.		

IP Fax Switch 06 [SP No. 1-111-007]					
No.	FUNCTION			COMMENTS	
0-3	<p>Modem bit rate setting for reception Sets the modem bit rate for reception. The default is "0110" (14.4K bps).</p>				
	Bit 3	Bit 2	Bit 1	Bit 0	
	0	0	0	1	2400 bps
	0	0	1	0	4800 bps
	0	0	1	1	7200 bps
	0	1	0	0	9600 bps
	0	1	0	1	12.0 Kbps
	0	1	1	0	14.4 Kbps
	0	1	1	1	16.8 Kbps
	1	0	0	0	19.2 Kbps
	1	0	0	1	21.6 Kbps

Bit Switches

	1	0	1	0	24.0 Kbps
	1	0	1	1	26.4 Kbps
	1	1	0	0	28.8 Kbps
	1	1	0	1	31.2 Kbps
	1	1	1	0	33.6 Kbps
4-7	Modem setting for reception Sets the modem type for reception. The default is "0100" (V27ter, V29, V17).				
	Bit 7	Bit 6	Bit 5	Bit 4	
	0	0	0	1	V27ter
	0	0	1	0	V27ter, V29
	0	0	1	1	V27ter, V29, V33 (invalid)
	0	1	0	0	V27ter, V29, V17
	0	1	0	1	V27ter, V29, V17, V34*
	*V34 is not supported for IP-Fax communication.				

IP Fax Switch 07 [SP No. 1-111-008]		
No.	FUNCTION	COMMENTS
0	TSI information 0: Not added, 1: Added	Adds or does not add TSI information to NSS(S).
1	DCN transmission setting at T1 timeout 0: Not transmitted, 1: Transmitted	Transmits or does not transmit DCN at T1 timeout.
2	Not used	Do not change this setting.

3	Hang up setting at DIS reception disabled 0: No hang up 1: Hang up after transmitting DCN	Sets whether the machine disconnects after DIS reception.
4	Number of times for training 0: 1 time, 1: 2 times	Selects the number of times training is done at the same bit rate.
5	Space CSI transmission setting at no CSI registration 0: Not transmitted, 1: Transmitted	When "0" is selected, frame data is enabled. When "1" is selected, the transmitted data is all spaces.
6-7	Not used	Do not change these settings.

IP Fax Switch 08 [SP No. 1-111-009]		
No.	FUNCTION	COMMENTS
0-1	T1 timer adjustment Adjusts the T1 timer. The default is "00" (35 seconds). Bit 1: 0, Bit 0: 0 = 35 sec Bit 1: 0, Bit 0: 1 = 40 sec Bit 1: 1, Bit 0: 0 = 50 sec Bit 1: 1, Bit 0: 1 = 60 sec	-
2-3	T4 timer adjustment Adjust the T4 timer. The default is "00" (3 seconds). Bit 3: 0, Bit 2: 0 = 3 sec Bit 3: 0, Bit 2: 1 = 3.5 sec Bit 3: 1, Bit 2: 0 = 4 sec Bit 3: 1, Bit 2: 1 = 5 sec	-

Bit Switches

4-5	T0 timer adjustment Bit 5: 0, Bit 4: 0 = 75 sec Bit 5: 0, Bit 4: 1 = 120 sec Bit 5: 1, Bit 4: 0 = 180 sec Bit 5: 1, Bit 4: 1 = 240 sec	Adjusts the fail safe timer. This timer sets the interval between "setup" data transmission and T.38 phase decision. If your destination return is late on the network or G3 fax return is late, adjust the longer interval timer. The default is "00" (75 seconds).
6-7	Not used	Do not change these settings.

5.3 NCU PARAMETERS

- The following tables give the RAM addresses and the parameter calculation units that the machine uses for ringing signal detection and automatic dialing. The factory settings for each country are also given. Most of these must be changed by RAM read/write (SP2-102), but some can be changed using NCU Parameter programming (SP2-103); if SP2-103 can be used, this will be indicated in the Remarks column. The RAM is programmed in hex code unless (BCD) is included in the Unit column.

Address	Function					
680500	Country/Area code for NCU parameters					
	Use the Hex value to program the country/area code directly into this address, or use the decimal value to program it using SP2-103-001					
	Country /Area	Decimal	Hex	Country /Area	Decimal	Hex
	France	00	00	USA	17	11
	Germany	01	01	Asia	18	12
	UK	02	02	Hong Kong	20	14
	Italy	03	03	South Africa	21	15
	Austria	04	04	Australia	22	16
	Belgium	05	05	New Zealand	26	17
	Denmark	06	06	Singapore	24	18
	Finland	07	07	Malaysia	25	19
	Ireland	08	08	China	26	1A
	Norway	09	09	Taiwan	27	1B
	Sweden	10	0A	Korea	28	1C
Switzerland	11	0B	Turkey	32	20	

NCU Parameters

Address	Function					
	Portugal	12	0C	Greece	33	21
	Holland	13	0D	Hungary	34	22
	Spain	14	0E	Czech	35	23
	Israel	15	0F	Poland	36	24

Address	Function	Unit	Remarks
680501	Line current detection time	20 ms	Line current detection is disabled. Line current is not detected if 680501 contains FF.
680502	Line current wait time		
680503	Line current drop detect time		
680504	PSTN dial tone frequency upper limit (high byte)	Hz (BCD)	If both addresses contain FF(H), tone detection is disabled.
680505	PSTN dial tone frequency upper limit (low byte)		
680506	PSTN dial tone frequency lower limit (high byte)	Hz (BCD)	If both addresses contain FF(H), tone detection is disabled.
680507	PSTN dial tone frequency lower limit (low byte)		
680508	PSTN dial tone detection time	20 ms	If 680508 contains FF(H), the machine pauses for the pause time (address 68050D / 68050E). Italy: See Note 2.
680509	PSTN dial tone reset time (LOW)		
68050A	PSTN dial tone reset time (HIGH)		
68050B	PSTN dial tone continuous tone time		
68050C	PSTN dial tone permissible drop time		
68050D	PSTN wait interval (LOW)		-

Address	Function	Unit	Remarks
68050E	PSTN wait interval (HIGH)		
68050F	PSTN ring-back tone detection time	20 ms	Detection is disabled if this contains FF.
680510	PSTN ring-back tone off detection time	20 ms	-
680511	PSTN detection time for silent period after ring-back tone detected (LOW)	20 ms	-
680512	PSTN detection time for silent period after ring-back tone detected (HIGH)	20 ms	-
680513	PSTN busy tone frequency upper limit (high byte)	Hz (BCD)	If both addresses contain FF(H), tone detection is disabled.
680514	PSTN busy tone frequency upper limit (low byte)		
680515	PSTN busy tone frequency lower limit (high byte)	Hz (BCD)	If both addresses contain FF(H), tone detection is disabled.
680516	PSTN busy tone frequency lower limit (low byte)		
680517	PABX dial tone frequency upper limit (high byte)	Hz (BCD)	If both addresses contain FF(H), tone detection is disabled.
680518	PABX dial tone frequency upper limit (low byte)		
680519	PABX dial tone frequency lower limit (high byte)	Hz (BCD)	If both addresses contain FF(H), tone detection is disabled.
68051A	PABX dial tone frequency lower limit (low byte)		
68051B	PABX dial tone detection time	20 ms	If 68051B contains FF,

NCU Parameters

Address	Function	Unit	Remarks
68051C	PABX dial tone reset time (LOW)		the machine pauses for the pause time (680520 / 680521).
68051D	PABX dial tone reset time (HIGH)		
68051E	PABX dial tone continuous tone time		
68051F	PABX dial tone permissible drop time		
680520	PABX wait interval (LOW)		
680521	PABX wait interval (HIGH)		
680522	PABX ringback tone detection time	20 ms	If both addresses contain FF(H), tone detection is disabled.
680523	PABX ringback tone off detection time	20 ms	
680524	PABX detection time for silent period after ringback tone detected (LOW)	20 ms	If both addresses contain FF(H), tone detection is disabled.
680525	PABX detection time for silent period after ringback tone detected (HIGH)	20 ms	
680526	PABX busy tone frequency upper limit (high byte)	Hz (BCD)	If both addresses contain FF(H), tone detection is disabled.
680527	PABX busy tone frequency upper limit (low byte)		
680528	PABX busy tone frequency lower limit (high byte)	Hz (BCD)	If both addresses contain FF(H), tone detection is disabled.
680529	PABX busy tone frequency lower limit (low byte)		
68052A	Busy tone ON time: range 1	20 ms	-
68052B	Busy tone OFF time: range 1		

Address	Function	Unit	Remarks
68052C	Busy tone ON time: range 2	20 ms	
68052D	Busy tone OFF time: range 2		
68052E	Busy tone ON time: range 3		
68052F	Busy tone OFF time: range 3		
680530	Busy tone ON time: range 4		
680531	Busy tone OFF time: range 4		
680532	Busy tone continuous tone detection time		
680533	<p>Busy tone signal state time tolerance for all ranges, and number of cycles required for detection (a setting of 4 cycles means that ON-OFF-ON or OFF-ON-OFF must be detected twice).</p> <p>Tolerance (\pm)</p> <p>Bit 1: 0, Bit 0: 0 = 75% Bits 2 and 3 must always be kept at 0.</p> <p>Bit 1: 0, Bit 0: 0 = 50% Bits 2 and 3 must always be kept at 0.</p> <p>Bit 1: 0, Bit 0: 0 = 25%</p> <p>Bit 1: 0, Bit 0: 0 = 12.5%</p> <p>Bits 7, 6, 5, 4 - number of cycles required for cadence detection</p>		
680534	International dial tone frequency upper limit (high byte)	Hz (BCD)	If both addresses contain FF(H), tone detection is disabled.
680535	International dial tone frequency upper limit (low byte)		
680536	International dial tone frequency lower limit (high byte)	Hz (BCD)	If both addresses contain FF(H), tone detection is disabled.
680537	International dial tone frequency lower limit (low byte)		
680538	International dial tone detection time	20 ms	If 680538 contains FF, the machine pauses for the pause time (68053D / 68053E).
680539	International dial tone reset time (LOW)		

NCU Parameters

Address	Function	Unit	Remarks
68053A	International dial tone reset time (HIGH)		Belgium: See Note 2.
68053B	International dial tone continuous tone time		
68053C	International dial tone permissible drop time		
68053D	International dial wait interval (LOW)		
68053E	International dial wait interval (HIGH)		
68053F	Country dial tone upper frequency limit (HIGH)	Hz (BCD)	If both addresses contain FF(H), tone detection is disabled.
680540	Country dial tone upper frequency limit (LOW)		
680541	Country dial tone lower frequency limit (HIGH)		If both addresses contain FF(H), tone detection is disabled.
680542	Country dial tone lower frequency limit (LOW)		
680543	Country dial tone detection time	20 ms	If 680543 contains FF, the machine pauses for the pause time (680548 / 680549).
680544	Country dial tone reset time (LOW)		
680545	Country dial tone reset time (HIGH)		
680546	Country dial tone continuous tone time	-	-
680547	Country dial tone permissible drop time	20 ms	-
680548	Country dial wait interval (LOW)		

Address	Function	Unit	Remarks
680549	Country dial wait interval (HIGH)		
68054A	Time between opening or closing the DO relay and opening the OHDI relay	1 ms	See Notes 3, 6 and 8. SP2-103-012 (parameter 11).
68054B	Break time for pulse dialing	1 ms	See Note 3. SP2-103-013 (parameter 12).
68054C	Make time for pulse dialing	1 ms	See Note 3. SP2-103-014 (parameter 13).
68054D	Time between final OHDI relay closure and DO relay opening or closing	1 ms	See Notes 3, 6 and 8. SP2-103-015 (parameter 14). This parameter is only valid in Europe.
68054E	Minimum pause between dialed digits (pulse dial mode)	20 ms	See Note 3 and 8. SP2-103-016 (parameter 15).
68054F	Time waited when a pause is entered at the operation panel		SP2-103-017 (parameter 16). See Note 3.
680550	DTMF tone on time	1 ms	SP2-103-018 (parameter 17).
680551	DTMF tone off time		SP2-103-019 (parameter 18).
680552	Tone attenuation level of DTMF signals while dialing	-N x 0.5 -3.5 dBm	SP2-103-020 (parameter 19). See Note 5.
680553	Tone attenuation value difference between high frequency tone and	-dBm x 0.5	SP2-103-021 (parameter 20).

Address	Function	Unit	Remarks
	low frequency tone in DTMF signals		The setting must be less than -5dBm , and should not exceed the setting at 680552h above. See Note 5.
680554	PSTN: DTMF tone attenuation level after dialling	$-N \times 0.5$ -3.5 dBm	SP2-103-022 (parameter 21). See Note 5.
680555	ISDN: DTMF tone attenuation level after dialling	$-\text{dBm} \times 0.5$	See Note 5
680556	Not used	-	Do not change the settings.
680557	Time between 68054Dh (NCU parameter 14) and 68054Eh (NCU parameter 15)	1 ms	This parameter takes effect when the country code is set to France.
680558	Not used	-	Do not change the setting.
680559	Grounding time (ground start mode)	20 ms	The Gs relay is closed for this interval.
68055A	Break time (flash start mode)	1 ms	The OHDI relay is open for this interval.
68055B	International dial access code (High)	BCD	For a code of 100: 68055B - F1 68055C - 00
68055C	International dial access code (Low)		
68055D	PSTN access pause time	20 ms	This time is waited for each pause input after the PSTN access code. If this address contains FF[H], the pause time

Address	Function	Unit	Remarks
			stored in address 68054F is used. Do not set a number more than 7 in the UK.
68055E	Progress tone detection level, and cadence detection enable flags	Bit 7: 0, Bit 6: 0, Bit 5: 0 = -25.0 dBm Bit 7: 0, Bit 6: 0, Bit 5: 1 = -35.0 dBm Bit 7: 0, Bit 6: 1, Bit 5: 0 = -30.0 dBm Bit 7: 1, Bit 6: 0, Bit 5: 0 = -40.0 dBm Bit 7: 1, Bit 6: 1, Bit 5: 0 = -49.0 dBm Bits 2, 0 - See Note 2.	
68055F To 680564	Not used	-	Do not change the settings.
680565	Long distance call prefix (HIGH)	BCD	For a code of 0: 680565 – FF 680566 - FF
680566	Long distance call prefix (LOW)	BCD	
680567 to 680571	Not used	-	Do not change the settings.
680572	Acceptable ringing signal frequency: range 1, upper limit	1000/ N (Hz).	SP2-103-003 (parameter 02).
680573	Acceptable ringing signal frequency: range 1, lower limit		SP2-103-004 (parameter 03).
680574	Acceptable ringing signal frequency: range 2, upper limit		SP2-103-005 (parameter 04).
680575	Acceptable ringing signal frequency: range 2, lower limit		SP2-103-006 (parameter 05).
680576	Number of rings until a call is detected		1

NCU Parameters

Address	Function	Unit	Remarks
680577	Minimum required length of the first ring	20 ms	See Note 4. SP2-103-008 (parameter 07).
680578	Minimum required length of the second and subsequent rings	20 ms	SP2-103-009 (parameter 08).
680579	Ringling signal detection reset time (LOW)	20 ms	SP2-103-010 (parameter 09).
68057A	Ringling signal detection reset time (HIGH)		SP2-103-011 (parameter 10).
68057B to 680580	Not used	-	Do not change the settings.
680581	Interval between dialing the last digit and switching the Oh relay over to the external telephone when dialing from the operation panel in handset mode.	20 ms	Factory setting: 500 ms
680582	Bits 0 and 1 - Handset off-hook detection time Bit 1:0, Bit 0: 0 = 200 ms Bit 1:0, Bit 0: 1 = 800 ms Other Not used Bits 2 and 3 - Handset on-hook detection time Bit 3: 0, Bit 2: 0 = 200 ms Bit 3: 0, Bit 2: 1 = 800 ms Other Not used Bits 4 to 7 - Not used	-	
680583 To 6805A0	Not used	-	Do not change the settings.
6805A1	Acceptable CED detection frequency upper limit (high byte)	BCD (Hz)	If both addresses contain FF(H), tone

Address	Function	Unit	Remarks
6805A2	Acceptable CED detection frequency upper limit (low byte)		detection is disabled.
6805A3	Acceptable CED detection frequency lower limit (high byte)	BCD (Hz)	If both addresses contain FF(H), tone detection is disabled.
6805A4	Acceptable CED detection frequency lower limit (low byte)		
6805A5	CED detection time	20 ms \pm 20 ms	Factory setting: 200 ms
6805A6	Acceptable CNG detection frequency upper limit (high byte)	BCD (Hz)	If both addresses contain FF(H), tone detection is disabled.
6805A7	Acceptable CNG detection frequency upper limit (low byte)		
6805A8	Acceptable CNG detection frequency lower limit (high byte)	BCD (Hz)	If both addresses contain FF(H), tone detection is disabled.
6805A9	Acceptable CNG detection frequency lower limit (low byte)		
6805AA	Not used	-	Do not change the setting.
6805AB	CNG on time	20 ms	Factory setting: 500 ms
6805AC	CNG off time	20 ms	Factory setting: 3000 ms
6805AD	Number of CNG cycles required for detection	-	The data is coded in the same way as address 680533.
6805AE	Not used	-	Do not change the settings.
6805AF	Acceptable AI short protocol tone (800Hz) detection frequency upper limit (high byte)	Hz (BCD)	If both addresses contain FF(H), tone detection is disabled.

Address	Function	Unit	Remarks
6805B0	Acceptable AI short protocol tone (800Hz) detection frequency upper limit (low byte)		
6805B1	Acceptable AI short protocol tone (800Hz) detection frequency lower limit (high byte)	Hz(BCD)	If both addresses contain FF(H), tone detection is disabled.
6805B2	Acceptable AI short protocol tone (800Hz) detection frequency lower limit (low byte)		
6805B3	Detection time for 800 Hz AI short protocol tone	20 ms	Factory setting: 360 ms
6805B4	PSTN: Tx level from the modem	-N – 3 dBm	SP2-103-002 (parameter 01).
6805B5	PSTN: 1100 Hz tone transmission level	- N 6805B4 - 0.5N 6805B5 –3.5 (dB) See Note 7.	
6805B6	PSTN: 2100 Hz tone transmission level	- N6805B4 - 0.5N 6805B6 –3 (dB) See Note 7.	
6805B7	PABX: Tx level from the modem	- dBm	
6805B8	PABX: 1100 Hz tone transmission level	- N 6805B7 - 0.5N 6805B8 (dB)	
6805B9	PABX: 2100 Hz tone transmission level	- N 6805B7 - 0.5N 6805B9 (dB)	
6805BD	Modem turn-on level (incoming signal detection level)	-37-0.5N (dBm)	
6805BE to 6805C6	Not used	-	Do not change the settings.
6805C7	Bits 0 to 3 – Not used Bit 4 = V.34 protocol dump 0: Simple, 1: Detailed (default) Bits 5 to 7 – Not used.		

Address	Function	Unit	Remarks		
6805C8 to 6805D9	Not used	-	Do not change the settings.		
6805DA	T.30 T1 timer	1 s			
6805E0 bit 3	Maximum wait time for post message	0: 12 s 1: 30 s	1: Maximum wait time for post message (EOP/EOM/MPS) can be changed to 30 s. Change this bit to "1" if communication errors occur frequently during V.17 reception.		
6805E4	Bit 2 sets the level of the call signal, Bit 3 sets the call signal impedance	Bit 2	0	RT=0 (Low)	-
			1	RT=1 (High)	
		Bit 3	0	RZ=0 (High)	
			1	RZ=1 (Composite)	
6805E5	Bit 0 sets the ring detection method, Bit 1 sets the ring detection method when fixed.	Bit 0	0	Auto	If any setting is changed, select a setting that is higher than the default setting.
			1	Fixed	
		Bit 1	0	Use RDTP	
			1	Use RDTN	
	Bits 2 to 7: Not used				

Appendix:
Fax Service
Program

NOTES

1. If a setting is not required, store FF in the address.
2. Italy and Belgium only
 RAM address 68055E: the lower four bits have the following meaning.
 Bit 2 - 1: International dial tone cadence detection enabled (Belgium)
 Bit 1 - Not used
 Bit 0 - 1: PSTN dial tone cadence detection enabled (Italy)

If bit 0 or bit 2 is set to 1, the functions of the following RAM addresses are changed.

680508 (if bit 0 = 1) or 680538 (if bit 2 = 1): tolerance for on or off state

duration (%), and number of cycles required for detection, coded as in address 680533.

68050B (if bit 0 = 1) or 68053B (if bit 2 = 1): on time, hex code (unit = 20 ms)

68050C (if bit 0 = 1) or 68053C (if bit 2 = 1): off time, hex code (unit = 20 ms)

3. Pulse dial parameters (addresses 68054A to 68054F) are the values for 10 pps. If 20 pps is used, the machine automatically compensates.
4. The first ring may not be detected until 1 to 2.5 wavelengths after the time specified by this parameter.
5. The calculated level must be between 0 and 10.

The attenuation levels calculated from RAM data are:

High frequency tone:

- $-0.5 \times N_{680552/680554} - 3.5$ dBm
- $-0.5 \times N_{680555}$ dBm

Low frequency tone:

- $-0.5 \times (N_{680552/680554} + N_{680553}) - 3.5$ dBm
- $-0.5 \times (N_{680555} + N_{680553})$ dBm

 Note

- N_{680552} , for example, means the value stored in address 680552(H)

6. 68054A: Europe - Between Ds opening and Di opening, France - Between Ds closing and Di opening
68054D: Europe - Between Ds closing and Di closing, France - Between Ds opening and Di closing
7. Tone signals which frequency is lower than 1500Hz (e.g., 800Hz tone for AI short protocol) refer to the setting at 6805B5h. Tones which frequency is higher than 1500Hz refer to the setting at 6805B6h.
8. 68054A, 68054D, 68054E: The actual inter-digit pause (pulse dial mode) is the sum of the period specified by the RAM addresses 68054A, 68054D, and 68054E.

5.4 DEDICATED TRANSMISSION PARAMETERS

There are two sets of transmission parameters: Fax and E-mail

Each Quick Dial Key and Speed Dial Code has eight bytes of programmable parameters allocated to it. If transmissions to a particular machine often experience problems, store that terminal's fax number as a Quick Dial or Speed Dial, and adjust the parameters allocated to that number.

The programming procedure will be explained first. Then, the eight bytes will be described.

5.4.1 PROGRAMMING PROCEDURE

1. Set the bit 0 of System Bit Switch 00 to 1.
2. Enter Address Book Management mode ([User Tools]> System Settings> Administrator Tools > Address Book Management).
3. Select the address book that you want to program.
4. Press the "Dest." Key to enter the fax and e-mail parameter settings.
5. For the fax parameter, select "Fax Settings", for the E-mail parameter, select "E-mail Settings".
6. Press the "OK" key, and then press "Start" key. Make sure that the LED of the Start button lights green.
7. The settings for the switch 00 are now displayed. Press the bit number that you wish to change.
8. To scroll through the parameter switches, either:
9. Select the next switch: press "Next" or Select the previous switch: "Prev." until the correct switch is displayed. Then go back to step 6.
10. After the setting is changed, press "OK" key.
11. After finishing, reset bit 0 of System Bit Switch 00 to 0.

5.4.2 PARAMETERS

Fax Parameters

The initial settings of the following fax parameters are all FF(H) - all the parameters are disabled.

Switch 00
FUNCTION AND COMMENTS
<p>ITU-T T1 time (for PSTN G3 mode)</p> <p>If the connection time to a particular terminal is longer than the NCU parameter setting, adjust this byte. The T1 time is the value stored in this byte (in hex code), multiplied by 1 second.</p> <p>Range: 0 to 120 s (00h to 78h)</p> <p>FFh - The local NCU parameter factory setting is used.</p> <p>Do not program a value between 79h and FEh.</p>

Switch 01							
No	FUNCTION					COMMENTS	
0-4	Tx level					<p>If communication with a particular remote terminal often contains errors, the signal level may be inappropriate. Adjust the Tx level for communications with that terminal until the results are better.</p> <p>If the setting is "Disabled", the NCU parameter 01 setting is used.</p> <p>↓ Note</p> <ul style="list-style-type: none"> Do not use settings other than listed on the left. 	
	Bit4	Bit3	Bit2	Bit1	Bit0		
	0	0	0	0	0		0
	0	0	0	0	1		-1
	0	0	0	1	0		-2
	0	0	0	1	1		-3
	0	0	1	0	0		-4
	↓	↓	↓	↓	↓		↓
	0	1	1	1	1		-15
	1	1	1	1	1		Disabled

5-7	<p>Cable equalizer</p> <p>Bit 7: 0, Bit 6: 0, Bit 5: 0 = None</p> <p>Bit 7: 0, Bit 6: 0, Bit 5: 1 = Low</p> <p>Bit 7: 0, Bit 6: 1, Bit 5: 0 = Medium</p> <p>Bit 7: 0, Bit 6: 1, Bit 5: 1 = High</p> <p>Bit 7: 1, Bit 6: 1, Bit 5: 1 = Disabled</p>	<p>Use a higher setting if there is signal loss at higher frequencies because of the length of wire between the modem and the telephone exchange when calling the number stored in this Quick/Speed Dial.</p> <p>Also, try using the cable equalizer if one or more of the following symptoms occurs.</p> <p>Communication error with error codes such as 0-20, 0-23, etc.</p> <p>Modem rate fallback occurs frequently.</p> <p>Note</p> <ul style="list-style-type: none"> Do not use settings other than listed on the left. <p>If the setting is "Disabled", the bit switch setting is used.</p>
-----	--	---

Switch 02						
No	FUNCTION					COMMENTS
0-3	Initial Tx modem rate					<p>If training with a particular remote terminal always takes too long, the initial modem rate may be too high. Reduce the initial Tx modem rate using these bits.</p> <p>For the settings 14.4 or kbps slower, Switch 04 bit 4 must be changed to 0.</p> <p>Note</p> <ul style="list-style-type: none"> Do not use settings other than listed on the left. If the setting is "Disabled", the bit switch setting is used.
	Bit3	Bit2	Bit1	Bit0	bps	
	0	0	0	0	Not used	
	0	0	0	1	2400	
	0	0	1	0	4800	
	0	0	1	1	7200	
	0	1	0	0	9600	
	0	1	0	1	12000	
	0	1	1	0	14400	

Dedicated Transmission Parameters

	0	1	1	1	16800	
	1	0	0	0	19200	
	1	0	0	1	21600	
	1	0	1	0	24000	
	1	0	1	1	26400	
	1	1	0	0	28800	
	1	1	0	1	31200	
	1	1	1	0	33600	
	1	1	1	1	Disabled	
	Other settings: Not used					
4-7	Not used				Do not change the settings.	

Switch 03		
No	FUNCTION	COMMENTS
0-1	Inch-mm conversion before tx Bit 1: 0, Bit 0: 0 = Inch-mm conversion available Bit 1: 0, Bit 0: 1 = Inch only Bit 1: 1, Bit 0: 0 = Not used Bit 1: 1, Bit 0: 1 = Disabled	The machine uses inch-based resolutions for scanning. If "inch only" is selected, the printed copy may be slightly distorted at the other end if that machine uses mm-based resolutions. If the setting is "Disabled", the bit switch setting is used.
2-3	DIS/NSF detection method Bit 3: 0, Bit 2: 0 = First DIS or NSF Bit 3: 0, Bit 2: 1 = Second DIS or NSF Bit 3: 1, Bit 2: 0 = Not used Bit 3: 1, Bit 2: 1 = Disabled	(0, 1): Use this setting if echoes on the line are interfering with the set-up protocol at the start of transmission. The machine will then wait for the second DIS or NSF before sending DCS or NSS. If the setting is "Disabled", the bit switch setting is used.
4	V.8 protocol 0: Off	If transmissions to a specific destination always end at a lower modem rate (14,400 bps or lower),

	1: Disabled	disable V.8 protocol so as not to use V.34 protocol. 0: V.34 communication will not be possible. If the setting is "Disabled", the bit switch setting is used.
5	Compression modes available in transmit mode 0: MH only 1: Disabled	This bit determines the capabilities that are informed to the other terminal during transmission. If the setting is "Disabled", the bit switch setting is used.
6-7	ECM during transmission Bit 7: 0, Bit 6: 0 = Off Bit 7: 0, Bit 6: 1 = On Bit 7: 1, Bit 6: 0 = Not used Bit 7: 1, Bit 6: 1 = Disabled	For example, if ECM is switched on but is not wanted when sending to a particular terminal, use the (0, 0) setting.  Note <ul style="list-style-type: none"> ▪ V.8/V.34 protocol and JBIG compression are automatically disabled if ECM is disabled. ▪ If the setting is "Disabled", the bit switch setting is used.

Switch 04 - Not used (do not change the settings)
Switch 05 - Not used (do not change the settings)
Switch 06 - Not used (do not change the settings)
Switch 07 - Not used (do not change the settings)
Switch 08 - Not used (do not change the settings)
Switch 09 - Not used (do not change the settings)

E-mail Parameters

The initial settings of the following e-mail parameters are all "0" (all parameters disabled).

Switch 00		
No	FUNCTION	COMMENTS
0	MH Compression mode for e-mail attachments 0 : Off 1: On	Switches MH compression on and off for files attached to e-mails for sending.
1	MR Compression mode for e-mail attachments 0 : Off 1: On	Switches MR compression on and off for files attached to e-mails for sending.
2	MMR Compression mode for e-mail attachments 0 : Off 1: On	Switches MMR compression on and off for files attached to e-mails for sending.
3-6	Not used	Do not change these settings.
7	Designates the bits to reference for compression method of e-mail attachments 0 : Registered (Bit 0 to 6) 1: No registration.	The "0" selection (default) references the settings for Bits 00, 01, 02 above. The "1" selection ignores the selections of Bits 00, 01, 02.

Switch 01		
No	FUNCTION	COMMENTS
0	Original width of e-mail attachment: A4 0: Off 1: On	Sets the original width of the e-mail attachment as A4.
1	Original width of e-mail attachment: B4 0: Off 1: On	Sets the original width of the e-mail attachment as B4.
2	Original width of e-mail attachment: A3 0: Off 1: On	Sets the original width of the e-mail attachment as A3.
3-6	Not used	Do not change these settings.
7	Designates the bits to reference for original size of e-mail attachments 0: Registered (Bit 0 to 6) 1: No registration.	The "0" selection (default) references the settings for Bits 00, 01, 02 above. The "1" selection ignores the selections of Bits 00, 01, 02.

Switch 02		
No	FUNCTION	COMMENTS
0	Line resolution of e-mail attachment: 200 x 100 0: Off 1: On	Sets the line resolution of the e-mail attachment as 200 x100.

Dedicated Transmission Parameters

1	Line resolution of e-mail attachment: 200 x 200 0: Off 1: On	Sets the line resolution of the e-mail attachment as 200 x 200.
2	Line resolution of e-mail attachment: 200 x 400 0: Off 1: On	Sets the line resolution of the e-mail attachment as 200 x 400.
3	Not used	Do not change these settings.
4	Line resolution of e-mail attachment: 400 x 400 0: Off 1: On	Sets the line resolution of the e-mail attachment as 400 x 400.
5-6	Not used	Do not change these settings.
7	Designates the bits to reference for original size of e-mail attachments 0: Registered (Bit 0 to 6) 1: No registration.	The "0" selection (default) references the settings for Bits 00, 01, 02, 04 above. The "1" selection ignores the selections of Bits 00, 01, 02, 04.

Switch 03 - Not used (do not change the settings)

Switch 04		
No	FUNCTION	COMMENTS
0	Full mode address selection 0: Full mode address 1: No full mode (simple mode)	If the other ends have the addresses, which have the full mode function flag ("0"), this machine determines them as full mode standard machines. <ul style="list-style-type: none"> ▪ This machine attaches the "demand of reception confirmation" to a message when transmitting. ▪ This machine updates the reception capability to the address book when receiving.
1-7	Not used	Do not change these settings.

Switch 05		
No	FUNCTION	COMMENTS
0	Direct transmission selection to SMTP server 0: ON 1: OFF	Allows or does not allow the direct transmission to SMTP server.
1-7	Not used	Do not change these settings.

Switch 06 - Not used (do not change the settings)
Switch 07 - Not used (do not change the settings)
Switch 08 - Not used (do not change the settings)
Switch 09 - Not used (do not change the settings)

5.5 SERVICE RAM ADDRESSES

CAUTION

- Do not change the settings which are marked as "Not used" or "Read only."

680000(H) - Machine code

680001 to 680004(H) - ROM version (Read only)

680001(H) - Revision number (BCD)

680002(H) - Year (BCD)

680003(H) - Month (BCD)

680004(H) - Day (BCD)

680005(H) - Machine code 2 (check ram2)

680006 to 680015(H) - Machine's serial number (16 digits - ASCII)

680016(H) - Language code

Bit0: Japanese, Bit1: English (UK), Bit2: English (USA), Bit3: French,

Bit4: German, Bit5: Spanish, Bit6: Italian, Bit7: Dutch, Bit8: Swedish,

Bit9: Norwegian, Bit10: Danish, Bit11: Finnish, Bit12: Czech,

Bit13: Hungarian, Bit14: Polish, Bit15: Portuguese, Bit16: Russian,

Bit17: Traditional Chinese, Bit18: Simplified Chinese, Bit19: Hangul

680018(H) - Total program checksum (low)

680019(H) - Total program checksum (high)

680020 to 68003F(H) - System bit switches

680050 to 68005F(H) - Printer bit switches

680060 to 68007F(H) - Communication bit switches

680080 to 68008F(H) - G3 bit switches

680090 to 68009F(H) - G3-2 bit switches: Not used

6800A0 to 6800AF(H) - G3-3 bit switches: Not used

6800D0(H) - User parameter switch 00 (SWUER_00) : Not used

6800D1(H) - User parameter switch 01 (SWUSR_01) : Not used

6800D2(H) - User parameter switch 02 (SWUSR_02)

Bit 0: Forwarding mark printing on forwarded messages

0: OFF, 1: ON (Print)

Bit 1: Center mark printing on received copies

(This switch is not printed on the user parameter list.)

0: OFF, 1: ON (Print)

Bit 2: Reception time printing

(This switch is not printed on the user parameter list.)

0: OFF, 1: ON (Print)

Bit 3: TSI print on received messages 0: OFF, 1: ON (Print)

Bit 4: Checkered mark printing

(This switch is not printed on the user parameter list.)

0: OFF, 1: ON (Print)

Bit 5: Not used

Bit 6: Not used

Bit 7: Not used

6800D3(H) - User parameter switch 03 (SWUSR_03: Automatic report printout)

Bit 0: Transmission result report (memory transmissions) 0: Off, 1: On

Bit 1: Not used

Bit 2: Memory storage report 0: Off, 1: On

Bit 3: Polling reserve report (polling reception) 0: Off, 1: On

Bit 4: Polling result report (polling reception) 0: Off, 1: On

Bit 5: Transmission result report (immediate transmissions) 0: Off, 1: On

Bit 6: Not used

Bit 7: Journal 0: Off, 1: On

6800D4(H) - User parameter switch 04 (SWUSR_04: Automatic report printout)

Bit 0: Not used

Bit 1: Automatic communication failure report and transfer result report output 0: Off, 1: On

Bits 2 to 3: Not used

Bit 4: Indicates the parties 0: Not indicated, 1: Indicated

Bit 5: Include sender's name on reports 0: Off, 1: On

Bit 6: Not used

Bit 7: Inclusion of a sample image on reports 0: Off, 1: On

6800D5(H) - User parameter switch 05 (SWUSR_05)

Bit 0: Substitute reception when the base copier is in an SC condition

0: Enabled, 1: Disabled

Bits 1 and 2: Condition for substitute rx when the machine cannot print messages (Paper end, toner end, jam, and during night mode)

Bit 2: 0, Bit 1: 0 = The machine receives all the fax messages.

Bit 2: 0, Bit 1: 1 = The machine receives the fax messages with RTI or CSI.

Bit 2: 1, Bit 1: 0 = The machine receives the fax messages with the same ID code.

Bit 2: 1, Bit 1: 1 = The machine does not receive anything.

Bits 3 and 4: Not used

Bit 5: Just size printing 0: Off, 1: On

Bit 6: Not used

Bit 7: Add paper display when a cassette is empty 0: Off, 1: On

6800D6(H) - User parameter switch 06 (SWUSR_06): Not used

6800D7(H) - User parameter switch 07 (SWUSR_07)

Bits 0 and 1: Not used

Bit 2: Parallel memory transmission 0: Off, 1: On

Bits 3 to 7: Not used

6800D8(H) - User parameter switch 08 (SWUSR_08)

Bits 0 and 1: Not used.

Bit 2: Authorized reception

0: Only faxes from senders whose RTIs/CSIs are specified for this feature are accepted.

1: Only faxes from senders whose RTIs/CSIs are not specified for this feature are accepted.

Bits 3 to 7: Not used.

6800D9(H) - User parameter switch 09 (SWUSR_09): Not used

6800DA(H) - User parameter switch 10 (SWUSR_0A)

Bits 0 to 2: Not used

Bit 3: Page reduction 0: Off, 1: On

Bits 4 and 5: Not used

Bit 6: Use both e-mail notification and printed reports to confirm the transmission results 0: Off, 1: On

Bit 7: Not used

6800DB(H) - User parameter switch 11 (SWUSR_0B)

Bits 0 and 1: Not used

Bit 2: White original detection 0: Off, 1: On (alarm and alert message on the LCD)

Bits 3 and 4: Not used

Bit 6: Printout of messages received while acting as a forwarding station 0: Off, 1: On

Bit 7: Not used

6800DC(H) - User parameter switch 12 (SWUSR_0C): Not used

6800DD(H) - User parameter switch 13 (SWUSR_0D): Not used

6800DE(H) - User parameter switch 14 (SWUSR_0E)

Bit 0: Message printout while the machine is in Night Printing mode 0: On, 1: Off

Bit 1: Maximum document length detection 0: Double letter, 1: Longer than double-letter (well log) – up to 1,200 mm

Bit 2: Not used

Bit 3: Fax mode settings, such as resolution, before a mode key (Copy/Fax/Printer/Scanner) is pressed 0: Not cleared, 1: Cleared

Bits 4 to 7: Not used

6800DF(H) - User parameter switch 15 (SWUSR_0F)

(This switch is not printed on the user parameter list.)

Bits 0, 1 and 2: Cassette for fax printout

Bit 2: 0, Bit 1: 0, Bit 0: 1 = 1st paper feed station

Bit 2: 0, Bit 1: 1, Bit 0: 0 = 2nd paper feed station

Bit 2: 0, Bit 1: 1, Bit 0: 1 = 3rd paper feed station

Bit 2: 1, Bit 1: 0, Bit 0: 0 = 4th paper feed station

Bit 2: 1, Bit 1: 0, Bit 0: 1 = LCT

Other settings Not used

Bits 3 and 4: Not used

Bit 5: Using the cassette specified by bits 0, 1 and 2 above only 0: On, 1: Off

Bits 6 and 7: Not used

6800E0(H) – User parameter switch 16 (SWUSR_10)

(This switch is not printed on the user parameter list.)

Bits 0 and 1: Not used

Bit 2: Paper size selection priority for an A4 size fax message when A4/LT size paper is not available. 0: A3 has priority, 1: B4 has priority

Bits 3 to 7: Not used

6800E1(H) – User parameter switch 17 (SWUSR_11)

Bits 0 and 1: Not used

Bit 2: Inclusion of the "Add" button when a sequence of Quick/Speed dials is selected for broadcasting 0: Not needed, 1: Needed

Bit 3: Not used

Bit 4: Reconfirmation of an address before press "Start" key. 0: Not displayed, 1: Displayed

Bits 5 and 6: Not used

Bit 7: Press "Start" key without an original when using the on hook dial or the external telephone,

0: displays "Cannot detect original size". 1: Receives fax messages.

6800E2(H) - User parameter switch 18 (SWUSR_12)

Bit 0: TTI date 0: Off, 1: On

Bit 1: TTI sender 0: Off, 1: On

Bit 2: TTI file number 0: Off, 1: On

Bit 3: TTI page number 0: Off, 1: On

Bits 4 to 7: Not used

6800E3(H) - User parameter switch 19 (SWUSR_13)

Bit 0: Not used

Bit 1: Journal format

0: The Journal is separated into transmissions and receptions

1: The Journal is separated into G3-1, G3-2, and G3-3 communications

Bit 2: Not used

Bit 3: 90° image rotation during B5 portrait Tx (This switch is not printed on the user parameter list.) 0: Off, 1: On

Service RAM Addresses

Bit 4: Reduction of sample images on reports to 50% in the main scan and sub-scan directions. (This switch is not printed on the user parameter list.) 0: Technician adjustment (printer switch 0E bits 3 and 4), 1: 50% reduction

Bit 5: Use of A5 size paper for reports (This switch is not printed on the user parameter list.) 0: Off, 1: On

Bits 6 and 7: Not used

6800E4(H) - User parameter switch 20 (SWUSR_14)

Bit 0: Automatic printing of the LAN fax result report 0: Off, 1: On

Bit 1: Not used.

Bits 2 to 5: Store documents in memory which could not be printed from PC fax (LAN fax) driver

Bit 5	Bit 4	Bit 3	Bit 2	Setting
0	0	0	0	0 min.
0	0	0	1	1 min.
↓	↓	↓	↓	↓
1	1	1	0	14 min.
1	1	1	1	15 min.

Bits 6 and 7: Not used.

6800E5(H) - User parameter switch 21 (SWUSR_15)

Bit 0: Print results of sending reception notice request message 0: Disabled (print only when error occurs), 1: Enabled

Bit 1: Respond to e-mail reception acknowledgment request 0: Disabled, 1: Enabled

Bit 2: Not used

Bit 3: File format for forwarded folders 0: TIFF, 1:PDF

Bit 4: Transmit Journal by E-mail 0: Disabled, 1: Enabled

Bit 5: Not used

Bit 6: Network error display 0: Displayed, 1: Not displayed

Bit 7: Transmit error mail notification 0: Enabled, 1: Disabled

6800E6(H) - User parameter switch 22 (SWUSR_16)

(This switch is not printed on the user parameter list.)

Bit 0: Dial tone detection (PSTN 1) 0: Disabled, 1: Enabled

Bits 1 to 3: Not used

Bits 4 to 7: Setting the number of times of address input using numeric key 0: Off, 1 to 15: On

6800E7(H) - User parameter switch 23 (SWUSR_17): Not used

6800E8(H) - User parameter switch 24 (SWUSR_18): Not used

6800E9(H) - User parameter switch 25 (SWUSR_19)

Bits 0 to 3: Not used

Bit 4: RDS operation 0: Not acceptable, 1: Acceptable for the limit specified by system switch 03



- This bit is only effective when RDS operation can be selected by the user (see system switch 02).

Bits 5 to 7: Not used

6800EA(H) and 6800EB(H) - User parameter switches 26 and 27 (SWUSR_1A and 1B): Not used

6800EC(H) - User parameter switch 28 (SWUSR_1C)

- Ringing times setting in the TEL line priority mode: 00 to 99 (BCD)

6800ED(H) - User parameter switch 29 (SWUSR_1D): Not used

6800EE(H) and 6800EF(H) - User parameter switches 30 and 31 (SWUSR_1E and 1F): Not used

6800F0(H) - User parameter switch 32 (SWUSR_20)

Bit 0: Quotation priority for a destination when there is no destination of the specified type

0: Paper output priority = Priority order: 1. IP-fax destination, 2. Fax Number, 3. E-mail address, 4. Folder

1: Electric putout order = Priority order: 1. E-mail address, 2. Folder, 3. IP-fax destination, 4. Fax number

Bits 1 to 7: Not used

6800F1(H) - User parameter switch 33 (SWUSR_21): Not used

6800F2(H) - User parameter switch 34 (SWUSR_22)

Bit 0: Gatekeeper server used with IP-Fax 0: Disabled, 1: Enabled

Bit 1: SIP server used with IP-Fax 0: Disabled, 1: Enabled

Bits 2 to 7: Not used

680100 to 68010F(H) - G4 Parameter Switches – Not used

680110 to 68012F(H) - G4 Internal Switches – Not used

680130 to 68016F(H) - Service Switches (SCU) – Not used

680170 to 68017F(H) - IFAX Switches

680180 to 68018F(H) - IP-FAX Switches

680190 to 6801AF(H) - Service station's fax number (SP3-101)

6801B0 to 6801B9(H) - Own fax PABX extension number

6801BA to 6801C3(H) - Own fax number (PSTN) – Not used

6801C4 to 6801D7(H) - Own fax number (ISDN G4) – Not used

6801D8 to 6801E3(H) - The first subscriber number (ISDN G3) – Not used

6801E4 to 6801EF(H) - The second subscriber number (ISDN G3) – Not used
6801F0 to 6801FB(H) - The first subscriber number (ISDN G4) – Not used
6801FC to 680207(H) - The second subscriber number (ISDN G4) – Not used
680208 to 68021B(H) - PSTN-1 RTI (Max. 20 characters - ASCII) - See the following note.
68021C to 68022F(H) - PSTN-2 RTI (Max. 20 characters - ASCII) - Not used
680230 to 680246(H) - PSTN-3 RTI (Max. 20 characters - ASCII) - Not used
680247 to 680286(H) - TTI 1 (Max. 64 characters - ASCII) - See the following note.
680287 to 6802C6(H) - TTI 2 (Max. 64 characters - ASCII) - Not used
6802C7 to 680306(H) - TTI 3 (Max. 64 characters - ASCII) - Not used
680307 to 68031A(H) - PSTN-1 CSI (Max. 20 characters - ASCII)
68031B to 68032E(H) - PSTN-2 CSI (Max.20 characters - ASCII) - Not used
68032F to 680342(H) - PSTN-3 CSI (Max.20 characters - ASCII) - Not used
680343(H) - Number of PSTN-1 CSI characters (Hex)
680344(H) - Number of PSTN-2 CSI characters (Hex) - Not used
680345(H) - Number of PSTN-3 CSI characters (Hex) - Not used



- If the number of characters is less than the maximum (20 for RTI, 64 for TTI), add a stop code (00[H]) after the last character.

680370(H) ID for transmission and reception (Read only – Do not change the settings)
680374 to 680375(H) - Envelopment ID for the envelopment reception (BCD)
680380 to 680387(H) - Last power off time (Read only)
680380(H) - 01(H) - 24-hour clock, 00(H) - 12-hour clock (AM), 02(H) - 12-hour clock (PM)
680381(H) - Year (BCD)
680382(H) - Month (BCD)
680383(H) - Day (BCD)
680384(H) – Hour
680385(H) – Minute
680386(H) – Second
680387(H) - 00: Monday, 01: Tuesday, 02: Wednesday, /// , 06: Sunday
680394(H) - Optional equipment – Not used
680395(H) - Optional equipment (Read only – Do not change the settings)
Bits 0 to 3: Not used
Bit 4: G3-2 0: Not installed, 1: Installed
Bit 5: G3-3 0: Not installed, 1: Installed
Bit 6 and 7: Not used
680401 to 68040D – Not used
680410(H) - G3-1 Modem ROM version (Read only)
680412(H) - G3-2 Modem ROM version – Not used

680414(H) - G3-3 Modem ROM version – Not used
680420(H) - Number of multiple sets print (Read only)
680476(H) - Time for economy transmission – Not used
68048C(H) - Dial in (BCD)
680492(H) - Transmission monitor volume 00 - 07(H)
680493(H) - Reception monitor volume 00 - 07(H)
680494(H) - On-hook monitor volume 00 - 07(H)
680495(H) - Dialing monitor volume 00 - 07(H)
680496(H) - Buzzer volume 00 - 07(H)
680497(H) - Beeper volume 00 - 07(H)
6804A8(H) - Machine code (Check ram 4)
6804D2(H) - Serial number (Max. 8 characters ASCII)
685E6C to 685E6F(H) - Transmission counter (HEX)
685E70 to 685E73(H) - Reception counter (HEX)
685EDC to 685EDF(H) - E-mail transmission counter (HEX)
685EE0 to 685EE3(H) - E-mail reception counter (HEX)
688E8E to 68918D(H) - SIP server address (Read only)
688E8E(H) - Proxy server - Main (Max. 128 characters - ASCII)
688F0E(H) - Proxy server - Sub (Max. 128 characters - ASCII)
688F8E(H) - Redirect server - Main (Max. 128 characters - ASCII)
68900E(H) - Redirect server - Sub (Max. 128 characters - ASCII)
68908E(H) - Registrar server - Main (Max. 128 characters - ASCII)
68910E(H) - Registrar server - Sub (Max. 128 characters - ASCII)
68918E(H) - Gatekeeper server address - Main (Max. 128 characters - ASCII)
68920E(H) - Gatekeeper server address - Sub (Max. 128 characters - ASCII)
68928E(H) - Arias Number (Max. 128 characters - ASCII)
68930E(H) - SIP user name (Max. 128 characters - ASCII)
68938E(H) - SIP authentication password (Max. 128 characters - ASCII)
68938E(H) - **SIP digest authentication password** (Max. 128 characters - ASCII)
68940E(H) - Gateway address information (Max. 7100 characters - ASCII)
68AFCA(H) - Stand-by port number for H.232 connection
68AFCCH) - Stand-by port number for SIP connection
68AFCE(H) - RAS port number
68AFD0(H) - Gatekeeper port number
68AFD2(H) - Port number of data waiting for T.38
68AFD4(H) - Port number of SIP server
68AFD6(H) - Priority for SIP and H.323 0: H.323, 1: SIP
68AFD7(H) - SIP function 0: Disabled, 1: Enabled

Service RAM Addresses

68AFD8(H) - H.323 function 0: Disabled, 1: Enabled

68AFD9(H) - SIP digest authentication function 0: Disabled, 1: Enabled

68AFDA(H) - IP-Fax backup data 00 - 600 (H)

69ECBE(H) - **69ECDE(H)** - Dial tone detection parameter (Max. 11 x 3 lines)

This initializes following order. [0x04, 0x40, 0x03, 0x60, 0x64, 0xf4, 0x01, 0x64, 0x04, 0xc8, 0x00]

D567
PAPER FEED UNIT PB1030

REVISION HISTORY		
Page	Date	Added/Updated/New
		None

D567 PAPER FEED UNIT PB1030

TABLE OF CONTENTS

1. REPLACEMENT AND ADJUSTMENT.....	1
1.1 PAPER TRAY UNIT.....	1
1.1.1 PAPER TRAY UNIT.....	1
If optional tray heater is not installed.....	1
If optional tray heater is installed.....	1
1.1.2 FEED ROLLER AND FRICTION PAD.....	2
1.2 SENSORS.....	3
1.3 DRIVE.....	4
1.3.1 DRIVE BLOCK.....	4
1.3.2 PAPER FEED MOTOR.....	5
1.3.3 PAPER FEED CLUTCH.....	5
1.3.4 TRAY MAIN BOARD.....	6

1. REPLACEMENT AND ADJUSTMENT

1.1 PAPER TRAY UNIT

1.1.1 PAPER TRAY UNIT

If optional tray heater is not installed

1. Lift copier off of the paper tray unit.

If optional tray heater is installed

1. Refer to section “Paper Tray Unit Heater” in the installation on the Field Service Manual, and carry out the following steps of that procedure in this order:
 - Step 2 (remove both paper trays)
 - Step 7 (remove copy tray)
 - Step 8 to 11 (remove rear cover)
 - Step 12 (remove upper left cover)
 - Step 13 (remove controller box)
 - Step 14 (remove support bracket)
2. Refer to section “Paper Tray Unit Heater” in the installation on the Field Service Manual, and do following:
 - Unscrew the ground line.
 - Unclamp the heater harness clamps.
 - Disconnect the heater harness clamps.
 - Unwrap and remove the core.
3. Pull the relay harness down and out through the hole in the PSU bracket, and then pull it all the way in through the hole at the rear of the (main) paper tray unit.
4. Remove the three screws fastening the paper tray unit to the copier (☛ “Paper Tray Unit Heater” step 4 in the installation on the Field Service Manual).
5. Lift the copier off the paper tray unit.

 Note

- To reinstall, refer to the procedure in section “Paper Tray Unit Heater” in the installation on the Field Service Manual. Carry out most of that procedure, starting from step 5 and omitting unnecessary steps.

1.1.2 FEED ROLLER AND FRICTION PAD

1. Take the tray out of the paper tray unit.

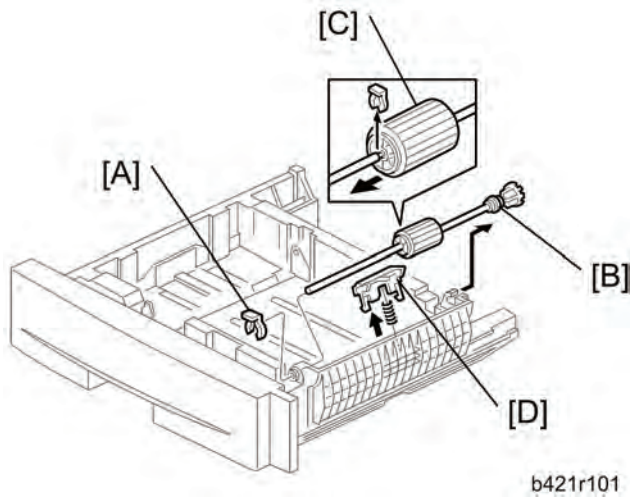

2. Clip ring [A]
3. Shaft assembly [B]
4. feed roller [C] (⌀ x 1)
5. Friction pad [D]

1.2 SENSORS

1. Remove the paper tray unit from the copier (☛ p.1).

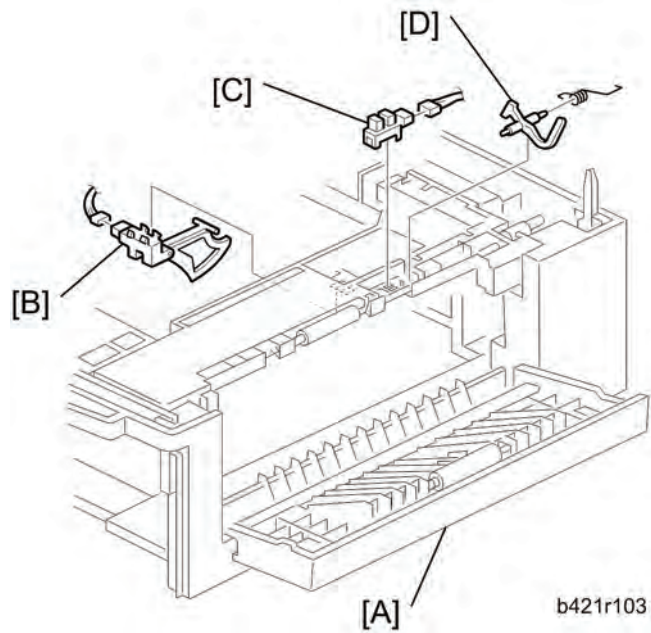

2. Open the PTU's right door [A].
3. Paper end sensor [B] (☛ x 1)
4. Paper feed sensor [C] (feeler [D] x 1, ☛ x 1)

1.3 DRIVE

1.3.1 DRIVE BLOCK

1. Remove the paper tray unit from the copier (☛ p.1).

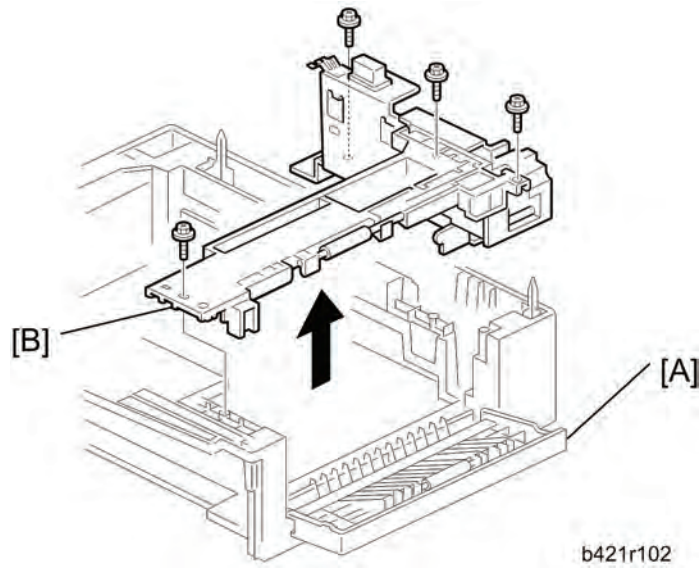

2. Open the paper tray unit's right door [A].
3. Drive block [B] (☛ x 4)

1.3.2 PAPER FEED MOTOR

1. Drive block (🔧 p.4)

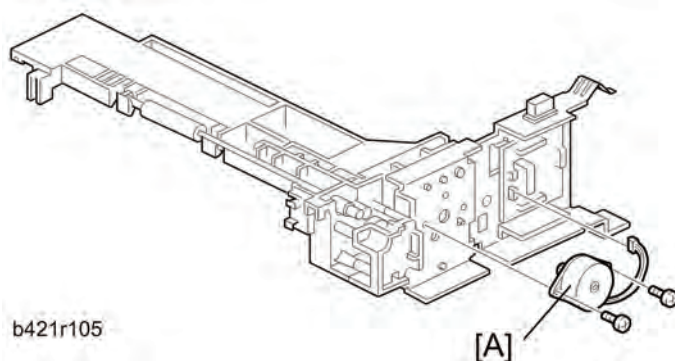

2. Paper feed motor [A] (🔧 x 1)

1.3.3 PAPER FEED CLUTCH

1. Drive block (🔧 p.4)

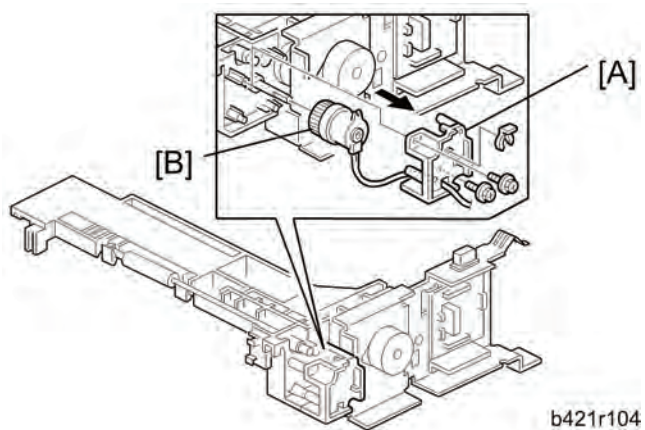

2. Detach the clutch cover [A] (🔧 x 1, 🔧 x 2)
3. Paper feed clutch [B] (🔧 x 1)

⏴ Note

- Detach the connector from the board side, not the clutch side.

Drive

1.3.4 TRAY MAIN BOARD

1. Drive block (🔩 p.4)

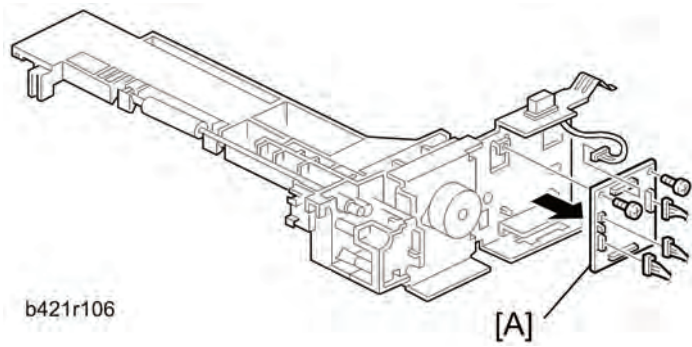

2. Tray main board [A] (🔩 x 2, all connectors)