

**Model K-C4/K-C4L
Machine Code:
D158/D159/D160/D161/D170
Field Service Manual**

18 Dec. 2012
Subject to change

Safety Notices

Important Safety Notices

Prevention of Physical Injury

1. Before disassembling or assembling parts of the copier and peripherals, make sure that the power cord is unplugged.
2. The wall outlet should be near the copier and easily accessible.
3. Note that some components of the copier and the paper tray unit are supplied with electrical voltage even if the main power switch is turned off.
4. If a job has started before the copier completes the warm-up or initializing period, keep hands away from the mechanical and electrical components because the starts making copies as soon as the warm-up period is completed.
5. The inside and the metal parts of the fusing unit become extremely hot while the copier is operating. Be careful to avoid touching those components with your bare hands.

Health Safety Conditions

Toner and developer are non-toxic, but if you get either of them in your eyes by accident, it may cause temporary eye discomfort. Try to remove with eye drops or flush with water as first aid. If unsuccessful, get medical attention.

Observance of Electrical Safety Standards

The copier and its peripherals must be installed and maintained by a customer service representative who has completed the training course on those models.

Safety and Ecological Notes for Disposal

1. Do not incinerate toner bottles or used toner. Toner dust may ignite suddenly when exposed to an open flame.
2. Dispose of used toner, developer, and organic photoconductors in accordance with local regulations. (These are non-toxic supplies.)
3. Dispose of replaced parts in accordance with local regulations.

Laser Safety

The Center for Devices and Radiological Health (CDRH) prohibits the repair of laser-based optical units in the field. The optical housing unit can only be repaired in a factory or at a location with the requisite equipment. The laser subsystem is replaceable in the field by a qualified Customer Engineer. The laser chassis is not repairable in the field. Customer engineers are therefore directed to return all chassis and laser subsystems to the factory or service depot when replacement of the optical subsystem is required.

WARNING

- Use of controls, or adjustment, or performance of procedures other than those specified in this manual may result in hazardous radiation exposure.

WARNING FOR LASER UNIT

WARNING: Turn off the main switch before attempting any of the procedures in the Laser Unit section. Laser beams can seriously damage your eyes.





CAUTION MARKING:



Conventions in this Manual

Symbols and Abbreviations

This manual uses several symbols and abbreviations. The meaning of those symbols and abbreviations are as follows:

	See or Refer to
	Clip ring
	Screw
	Connector
	Clamp
	E-ring
SEF	Short Edge Feed
LEF	Long Edge Feed

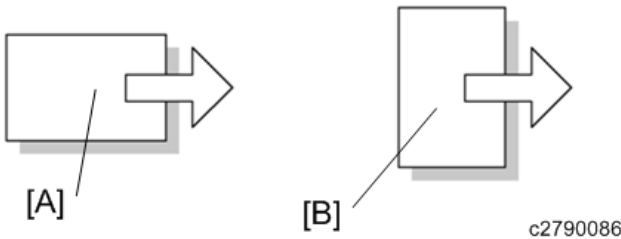

[A] Short Edge Feed (SEF)

[B] Long Edge Feed (LEF)

Cautions, Notes, etc.

The following headings provide special information:

WARNING

- FAILURE TO OBEY WARNING INFORMATION COULD RESULT IN SERIOUS INJURY OR DEATH.

⚠ CAUTION

- Obey these guidelines to ensure safe operation and prevent minor injuries.

↓ Note

- This information provides tips and advice about how to best service the machine.

TABLE OF CONTENTS

Safety Notices.....	1
△ Important Safety Notices	1
Prevention of Physical Injury.....	1
Health Safety Conditions.....	1
Observance of Electrical Safety Standards.....	1
Safety and Ecological Notes for Disposal.....	1
Laser Safety.....	2
Conventions in this Manual.....	3
Symbols and Abbreviations.....	3
Cautions, Notes, etc.....	3
1. Product Information	
Specifications.....	15
Machine Configuration.....	16
Product Overview.....	18
Component Layout.....	18
D160/D161/D170: CIS scanner Component Layout.....	19
D158/D159: CCD scanner Component Layout.....	20
Paper Path.....	21
Drive Layout.....	22
2. Installation	
Installation Requirements.....	25
Environment.....	25
Machine Level.....	26
Minimum Space Requirements.....	26
Power Requirements.....	27
Installation Flow Chart.....	28
Copier Installation.....	29
Accessory Check.....	29
Installation Procedure.....	31
Selecting the Panel Display Language (for D158/D159).....	36
Shutdown/Forced Shutdown Functions.....	37
Shutdown Function.....	37
Forced Shutdown Function.....	38

Instructions for the Customers.....	39
Platen Cover Installation.....	40
Accessory Check.....	40
Installation Procedure.....	40
ARDF Installation (for D158/D159).....	43
Accessory Check.....	43
Installation Procedure.....	43
When feeding thin paper.....	48
ARDF Installation (for D160/D161/D170).....	49
Accessory Check.....	49
Installation Procedure.....	49
Two-tray Paper Tray Unit Installation.....	54
Accessory Check.....	54
Installation Procedure.....	54
One-tray Paper Tray Unit Installation.....	58
Component Check.....	58
Installation Procedure.....	58
One-Bin Tray Installation.....	62
Component Check.....	62
Installation Procedure.....	63
Anti-condensation Heater Installation.....	70
Component Check.....	70
Installation Procedure.....	70
Tray Heaters.....	74
Mainframe Upper Tray Heater.....	74
Component Check.....	74
Installation Procedure.....	75
Mainframe Lower Tray Heater (Two-tray Model Only).....	77
Component Check.....	78
Installation Procedure.....	79
Heater for the Optional One-Tray Paper Feed Unit.....	81
Component Check.....	81
Installation Procedure.....	82

Heater for the Optional Two-Tray Paper Feed Unit.....	86
Component Check.....	86
Installation Procedure.....	87
Installing the Harness of the Heater.....	90
Counter Interface Unit.....	94
Component Check.....	94
Installation Procedure.....	94
GDI Expansion (D160/D161 only).....	99
Component Check.....	99
Installing the Expansion Component.....	99
Hard Disk Drive Option (D158/D159 only).....	102
Component Check.....	102
Installation Procedure.....	103
Data Overwrite Security.....	106
HDD Encryption.....	107
Controller Options.....	109
Overview.....	109
I/F Card Slot.....	109
SD Card Slots.....	109
SD Card Appli Move.....	110
Overview.....	110
Move Exec.....	110
Undo Exec.....	111
VM Card (D158/D159).....	112
Installation Procedure.....	112
Firmware Update Procedure	112
Copy Data Security Unit (D158/D159).....	114
Component Check.....	114
Installation Procedure.....	114
User Tool Setting.....	117
File Format Converter (D158/D159).....	117
Installation Procedure.....	117
Browser Unit (D158/D159).....	118

Installation Procedure.....	118
Fax Connection Unit (D158/D159).....	125
Installation Procedure.....	125
SD Card for Netware Printing (D158/D159).....	125
Installation Procedure.....	125
Bluetooth Interface Unit (D158/D159).....	126
Installation Procedure.....	126
Wireless LAN Interface Unit (D158/D159).....	127
Component Check.....	127
Installation Procedure.....	128
UP Mode Settings for Wireless LAN.....	130
SP Mode and UP Mode Settings for IEEE 802.11 a/b/g, Wireless LAN.....	131
IEEE 1284 Interface Board (D158/D159).....	131
Installation Procedure.....	131
Fax Unit (D158/D159).....	132
Component Check.....	132
Installation Procedure.....	133
Fax Settings.....	139
Memory Unit (D158/D159).....	140
Installation Procedure.....	140
Handset (D158/D159).....	140
Component Check.....	140
Installation Procedure.....	141
IC Card (D158/D159).....	143
Installation Procedure.....	143
Check All Connections.....	146

3. Preventive Maintenance

PM Tables.....	147
How to Reset the PM Counter.....	148
D160/D161/D170 Models.....	148
D158/D159 Models.....	148

4. Replacement and Adjustment

General Cautions.....	149
-----------------------	-----

Main Power Switch (Push SW).....	149
PCU (Photoconductor Unit).....	149
Transfer Roller.....	149
Scanner Unit.....	150
Laser Unit.....	150
Fusing Unit.....	150
Paper Feed.....	150
Special Tools and Lubricants.....	151
Exterior Covers & Operation Panel.....	152
Rear Cover.....	152
Output Tray, Exit Cover, Exit Rear Cover.....	152
Upper Covers (D158/D159).....	153
Operation Panel (D158/D159).....	154
Upper Covers (D160/D161/D170).....	155
Operation Panel (D160/D161/D170).....	157
Left Cover.....	158
Front Cover.....	159
Front Cover Switch (Interlock Switch).....	159
Front Right Cover.....	160
Right Rear Cover.....	160
Duplex Unit (D158/D159/D160/D161) / Right Door (D170)	161
By-pass Tray.....	162
Right Lower Cover (Two-tray Models Only).....	164
Right Lower Cover Switch (Two-tray Models Only).....	164
Platen Cover Sensor.....	165
Scanner Unit (D158/D159).....	166
Exposure Glass/DF Exposure Glass (CCD).....	166
Lens Block.....	168
SIO Board.....	169
Exposure Lamp.....	169
APS Sensor (Length).....	170
Scanner Motor.....	171
Scanner Home Position Sensor.....	173

Front Scanner Wire.....	173
Reassembling the Front Scanner Wire.....	177
Rear Scanner Wire.....	181
Reassembling the Rear Scanner Wire.....	184
Adjusting the Scanner Positions.....	186
Scanner Unit (D160/D161/D170).....	188
Scanner Unit.....	189
APS Sensors (Width/Length).....	191
CIS Unit and Scanner Drive Belt.....	193
Exposure Glass/DF Exposure Glass (CIS).....	195
Laser Unit.....	197
Location of Caution Decal.....	197
Toner Shield Glass.....	197
Laser Unit.....	198
Polygonal Mirror Motor.....	198
PCU Section.....	200
PCU.....	200
Pick-off Pawls and Toner Density Sensor.....	201
OPC Drum.....	201
Charge Roller and Cleaning Brush.....	202
Cleaning Blade.....	203
Developer.....	204
After Replacement or Adjustment.....	205
Toner Supply Motor.....	207
Paper Feed Section.....	208
Paper Feed Roller	208
Friction Pad.....	208
Exit Sensor.....	209
Registration Roller.....	211
Registration Clutch.....	213
Registration Sensor.....	214
Upper Paper Feed Clutch.....	215
Relay Clutch.....	216

Relay Sensor.....	217
Lower Paper Feed Clutch (Two-tray Models Only).....	217
Vertical Transport Sensor (Two-tray Models Only).....	218
Paper Size Switch.....	218
Paper End Sensor.....	219
Paper End Sensor: T1.....	219
Paper End Sensor: T2 (Two-tray Models Only).....	220
Tray Lift Motor.....	220
Tray Lift Sensor.....	221
By-pass Paper Length Sensor.....	222
By-Pass Paper Width Sensor.....	223
When replacing the by-pass paper width sensor.....	224
By-Pass Feed Roller and By-Pass Paper End Sensor.....	224
By-pass Feed Clutch and By-pass Tray Lift Clutch.....	225
By-pass Tray Lift Sensor.....	226
Image Transfer.....	227
Image Transfer Roller.....	227
Image Density Sensor.....	227
Fusing.....	229
Fusing Unit.....	229
Thermistor.....	229
Fusing Lamps.....	230
Hot Roller Stripper Pawls.....	231
Hot Roller.....	232
Thermostat.....	232
Pressure Roller and Bushings.....	233
NIP Band Width Adjustment.....	234
Duplex Unit (Duplex Models Only).....	236
Duplex Exit Sensor.....	236
Duplex Entrance Sensor.....	236
Duplex Inverter Sensor.....	237
Duplex Transport Motor.....	237
Duplex Inverter Motor.....	238

Electrical Components.....	240
Controller Board (GW+/GDI).....	240
Types of Controller board.....	240
Replacement Procedure (GW+ Controller).....	240
When Replacing the New Controller Board (GW+ Controller).....	243
After Installing the Controller Board (GW+ Controller).....	243
Replacement Procedure (GDI Controller).....	244
When Replacing the New Controller Board (GDI).....	245
HDD Unit (for D158/D159).....	245
Replacement Procedure.....	246
Quenching Lamp.....	247
High-Voltage Power Supply Board.....	248
BICU (Base-Engine Image Control Unit).....	248
Replacing the NVRAM on the BICU.....	250
Main Motor.....	250
Rear Exhaust Fan (Duplex Models Only).....	251
Left Exhaust Fan.....	252
PSU (Power Supply Unit).....	254
Gearbox.....	254
Replacement Procedure.....	254
Gear Arrangement in the Gearbox.....	256
Copy Adjustments Printing/Scanning.....	258
Printing.....	258
Scanning.....	261
ARDF Image Adjustment.....	263
5. Troubleshooting	
Troubleshooting Image Quality Problems.....	265
Marks (Vertical Streaks) on Prints and Copies due to Scanning Problems.....	265
Converting the ARDF DF2020 (D684) to Contact Scanning.....	266
Service Call Conditions.....	270
Summary.....	270
SC Code Descriptions.....	271
SC1xx: Scanning.....	271

SC2xx: Exposure (D158/D159).....	274
SC3xx: Image Processing.....	275
SC4xx: Image Processing.....	279
SC5xx: Paper Feed and Fusing.....	280
SC6xx: Device Communication.....	286
SC7xx: Peripherals.....	290
SC9xx: Miscellaneous.....	291
Electrical Component Defects.....	293
Sensors.....	293
Switches.....	296
Blown Fuse Conditions.....	298

6. Service Tables

Service Program Mode.....	299
SP Tables.....	299
Firmware Update.....	300
Firmware Update Procedure (D158/D159).....	300
Before You Begin.....	300
Preparation.....	300
Updating Procedure.....	301
Firmware Update Error.....	302
Firmware Update Procedure (D160/D161/D170).....	302
Engine (BICU).....	302
GDI (Printer/Scanner).....	304
NVRAM Data Upload/Download.....	308
Uploading Content of NVRAM to an SD card (D158/D159).....	308
Downloading an SD Card to NVRAM (D158/D159).....	309
NVRAM Data Upload/Download (D160/D161/D170).....	310
Engine.....	310
Controller.....	310
Using SP Modes.....	311
Adjusting Registration and Magnification.....	311
Display APS Data (SP 4301 1).....	312
D170/D160/D161 Models.....	312

D158/D159 Models.....	313
Memory Clear.....	314
Input Check.....	316
Input Check Table for Copier (D160/D161/D170).....	316
Input Check Table for Copier (D158/D159).....	320
Output Check.....	324
Serial Number Input (SP 5811) (D158/D159).....	328
Test Pattern Print	329
D160/D161/D170 models.....	329
D158/D159 models.....	330
Paper Jam Counters (SP 7504).....	331
SMC Print (SP 5990).....	333
SMC Print to SD Card (SP 5992).....	334
Overview.....	334
Procedure.....	334
File Names of the Saved SMC Lists.....	337
Original Jam History Display (SP 7508).....	337
Jam History Codes.....	338
SC History Display (SP 7403).....	338
SC History Codes.....	339

1. Product Information

Specifications

1

See "Appendices" for the following information:

- General Specifications
- Supported Paper Size
- Optional Equipment

Machine Configuration

Note

- The D158, D160 and D170 come with one standard paper tray. The D159 and D161 come with two standard paper trays.

D158/D159 (SP Models)

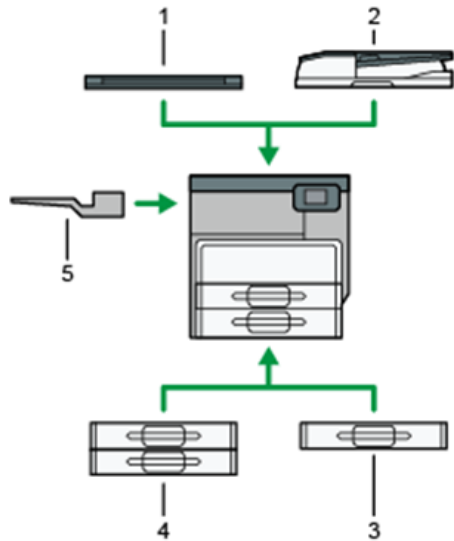

d1582240

Item	Machine Code	Call out
Platen cover	D700	[1]
ARDF	D684	[2]
Paper tray unit (1-tray type)	D698	[3]
Paper tray unit (2-tray type)	D699	[4]
1 bin tray	D697	[5]

D160/D161/D170

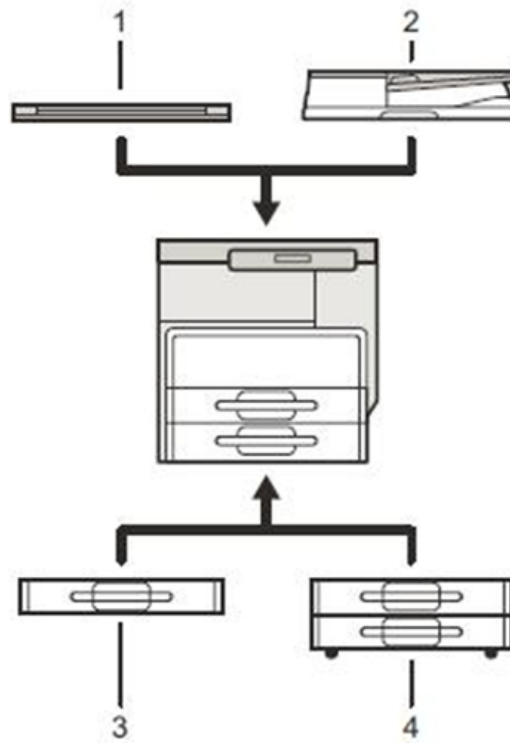

d1585019

Item	Machine Code	Call out
Platen cover	D700	[1]
ARDF	D724	[2]
Paper tray unit (1-tray type)	D698	[3]
Paper tray unit (2-tray type)	D699	[4]

Product Overview

1

Component Layout

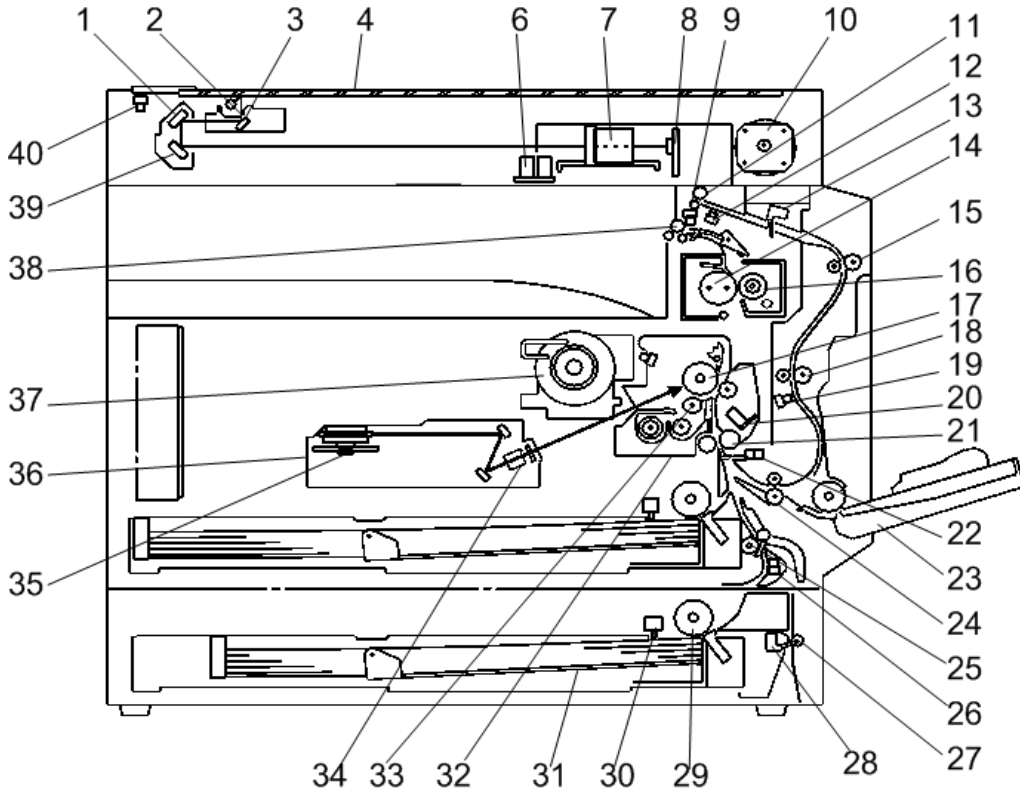

d1582141

Note

- The above illustration is the D158/D159 model.
- D170: No duplex unit
- D158/D159: CCD scanner
- D160/D161/D170: CIS scanner

1. 2nd Mirror	21. Registration Roller
2. Exposure Lamp	22. Registration Sensor
3. 1st Mirror	23. By-pass Tray
4. Exposure Glass	24. Lower Transport Roller
6. APS Sensor (Length)	25. Upper Relay Roller
7. Lens Block	26. Relay Sensor
8. SBU	27. Lower Relay Roller
9. Exit Sensor	28. Vertical Transport Sensor
10. Scanner Motor	29. Paper Feed Roller
11. Inverter Roller	30. Paper End Sensor
12. Duplex Inverter Sensor	31. Bottom Plate
13. Duplex Entrance Sensor	32. PCU
14. Hot Roller	33. Development Roller
15. Upper Transport Roller	34. F-theta Lens
16. Pressure Roller	35. Polygon Mirror Motor
17. OPC Drum	36. Laser Unit
18. Middle Transport Roller	37. Toner Supply Bottle Holder
19. Duplex Exit Sensor	38. Exit Roller
20. Image Density Sensor	39. 3rd Mirror
	40. Scanner HP Sensor

D160/D161/D170: CIS scanner Component Layout

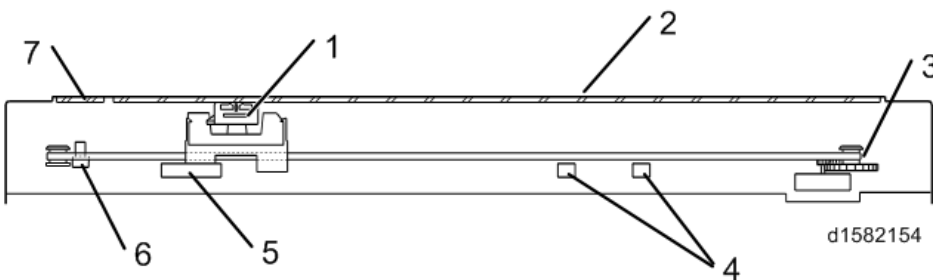

<ol style="list-style-type: none"> 1. CIS Unit 2. Exposure Glass 3. Scanner Motor 4. APS Sensor (Length) 	<ol style="list-style-type: none"> 5. APS Sensor (Width) 6. Scanner HP Sensor 7. DF Exposure Glass
--	---

D158/D159: CCD scanner Component Layout

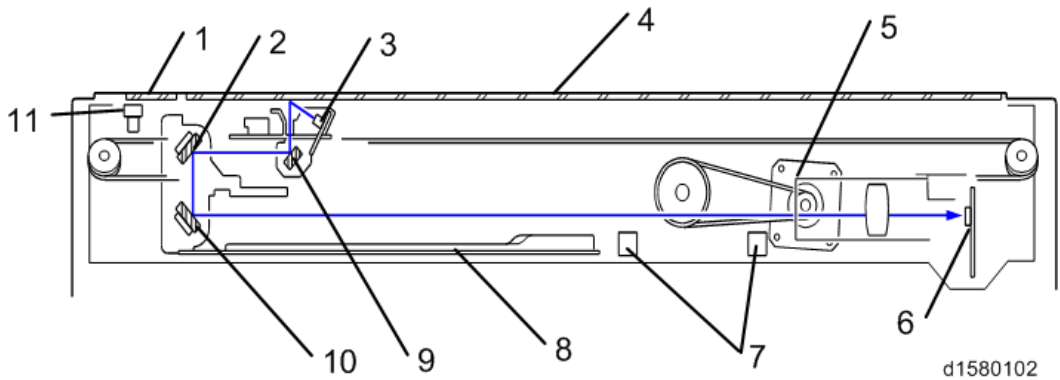

<ol style="list-style-type: none"> 1. DF Exposure Glass 2. 2nd Mirror 3. Exposure Lamp 4. Exposure Glass 5. Scanner Motor 6. SBU 	<ol style="list-style-type: none"> 7. APS Sensors 8. Scanner Heater 9. 1st Mirror 10. 3rd Mirror 11. Scanner HP Sensor
--	---

Paper Path

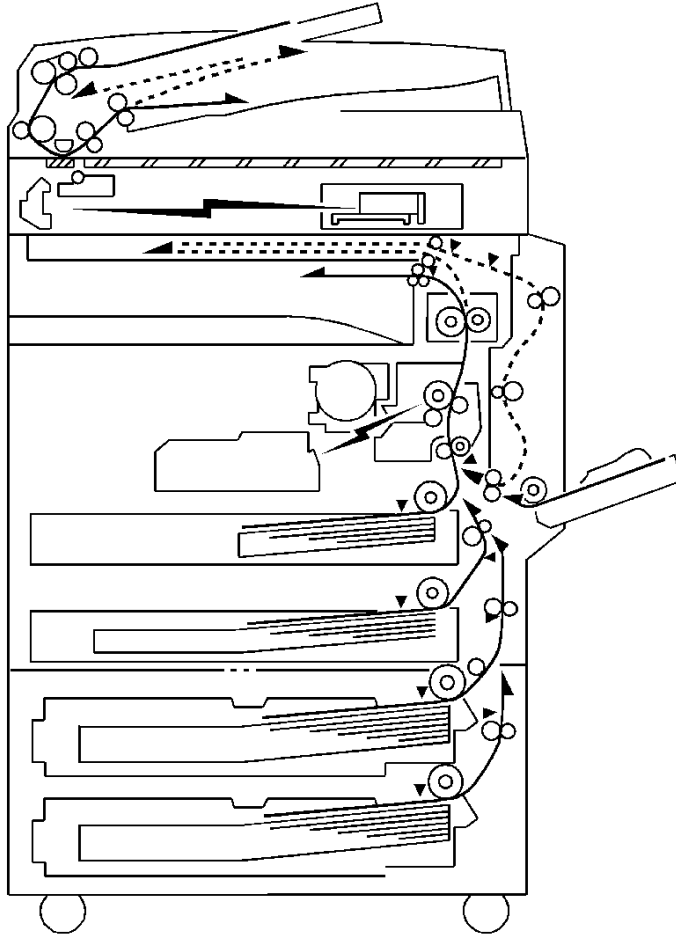

The D158, D159, D160, and D161 models have a duplex unit mounted on the right side of the machine.

All models have a by-pass tray.

Drive Layout

1

D158/D159 Scanner

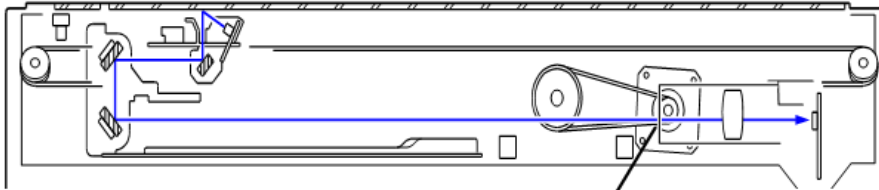

D160/D161/D170 Scanner

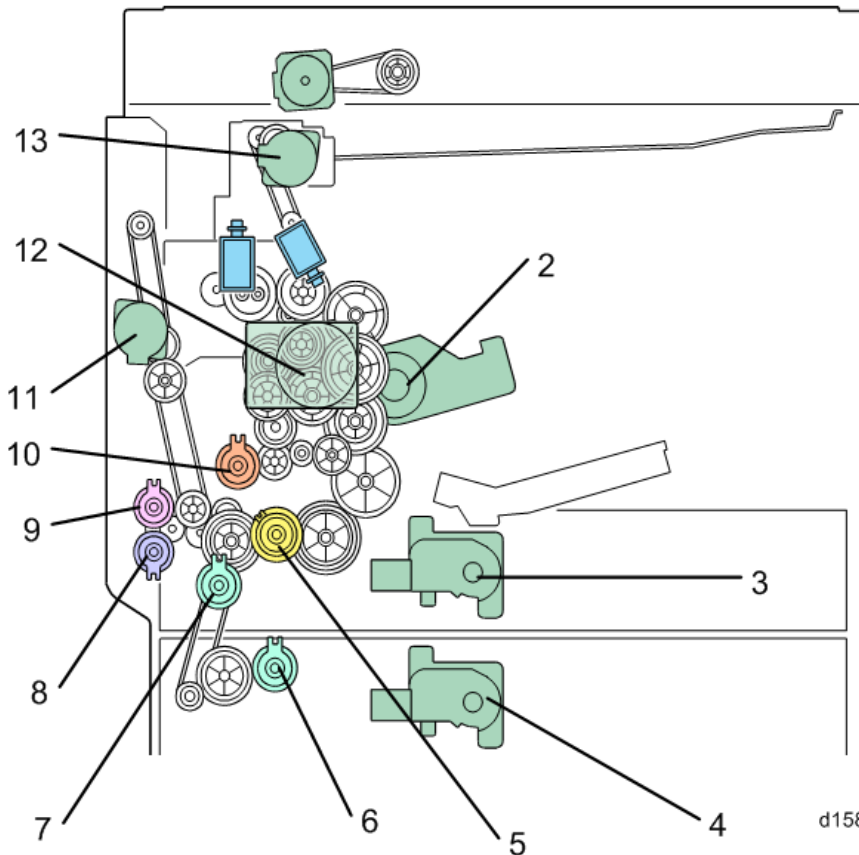
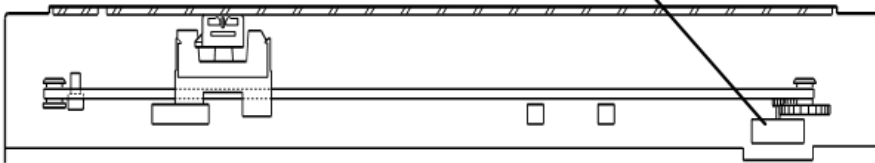

d1582155

1. Scanner Motor	8. By-pass Paper Feed Clutch
2. Toner Supply Motor	9. By-pass Tray Lift Clutch
3. Tray 1 Lift Motor	10. Registration Clutch
4. Tray 2Lift Motor	11. Duplex Motor
5. Upper Paper Feed Clutch	12. Main Motor
6. Lower Paper Feed Clutch	13. Inverter Motor
7. Relay Clutch	

2. Installation

Installation Requirements

⚠ CAUTION

- Before installing options, please do the following:
 - If there is a printer option in the machine, print out all data in the printer buffer.
 - Turn off the main switch and disconnect the power cord, the telephone line, and the network cable.

Environment

–Temperature and Humidity Chart–

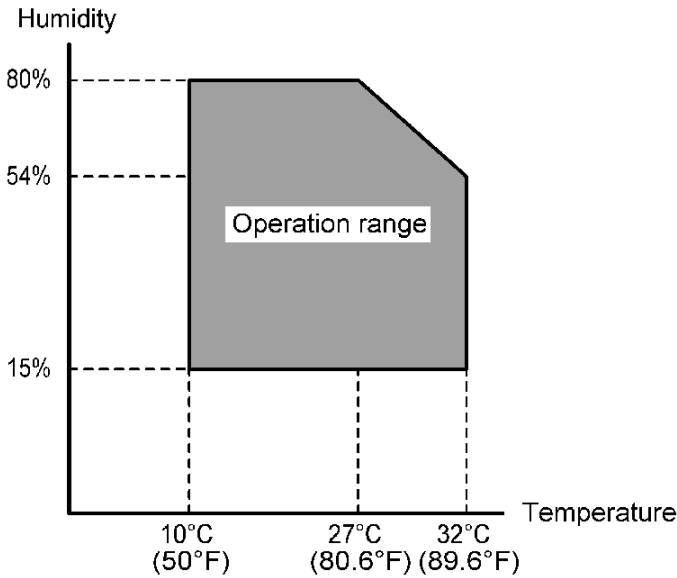

• Temperature Range:	10 - 32°C (50 - 89.6°F)
• Humidity Range:	15% to 80% RH
• Ambient Illumination:	Less than 1,500 lux (do not expose to direct sunlight)
• Ventilation:	3 times/hr/person or more
• Ambient Dust:	Less than 0.075 mg/m ³ (2.0 x 10 ⁻⁶ oz/yd ³)

- Avoid areas exposed to sudden temperature changes:
 - 1) Areas directly exposed to cool air from an air conditioner.
 - 2) Areas directly exposed to heat from a heater.
- Do not place the machine in areas where it can get exposed to corrosive gases.
- Do not install the machine at any location over 2,000 m (6,500 ft.) above sea level.
- Place the machine on a strong and level base. (Inclination on any side should be no more than 5 mm.)
- Do not place the machine where it is subjected to strong vibrations.

Machine Level

Front to back:	Within 5 mm (0.2") of level
Right to left:	Within 5 mm (0.2") of level

Minimum Space Requirements

Place the copier near the power source, providing clearance as shown:

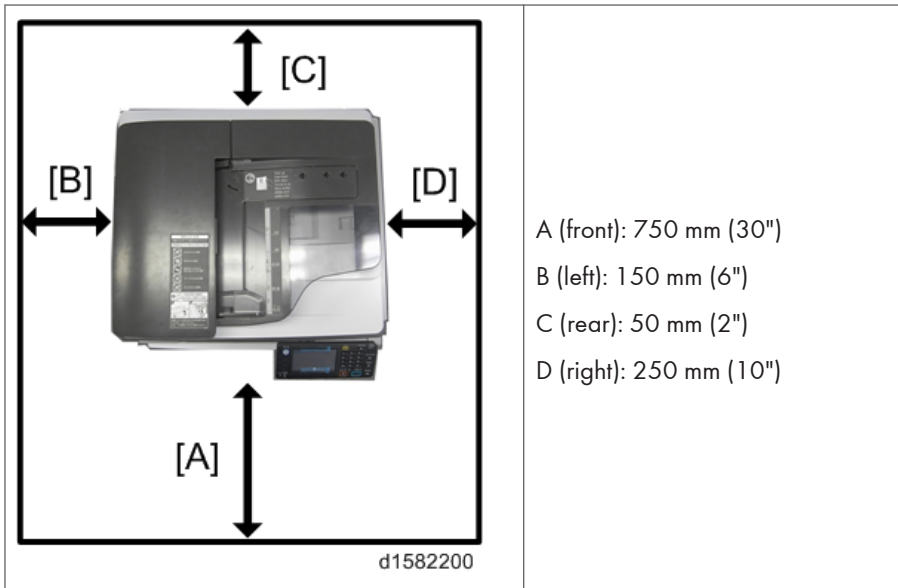

The recommended 750 mm (30") front space is sufficient to allow the paper tray to be pulled out. Additional front space is required to allow operators to stand at the front of the machine.

Power Requirements

CAUTION

- Make sure that the wall outlet is near the machine and easily accessible. After completing installation, make sure the plug fits firmly into the outlet.
- Avoid multi-wiring.
- Be sure to ground the machine.

Input voltage:

North America	120 - 127V 60Hz 12A
Europe, Asia, China	220V - 240V 50/60Hz 8A
Taiwan	110V 60Hz 13A

Installation Flow Chart

This flow chart shows the best procedure for installation.

2

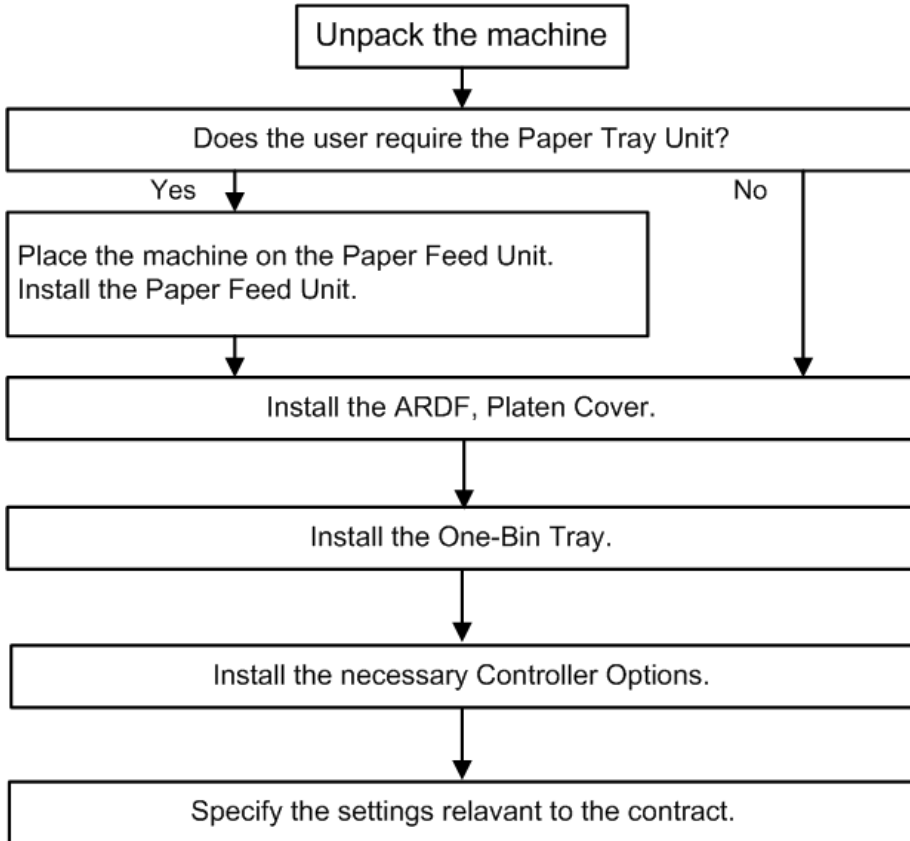

w_d1582001

Copier Installation

Accessory Check

Check that you have the accessories in this list.

SP Models (D158/D159)

2

No.	Description	-17	-27	-29	-21	-25	-19	Q'ty
1	Operating Instructions (paper)	Y	Y	Y	Y	Y	Y	-
2	Operating Instructions (CD-ROM)	Y	Y	Y	Y	Y	Y	-
3	CD-ROM – Printer	Y	Y	Y	Y	Y	Y	1
4	CD-ROM – Scanner	Y	Y	Y	Y	Y	Y	1
5	CD-ROM – Printer/Scanner manual	Y	Y	Y	Y	Y	Y	1
6	Operating Instructions – Printer/Scanner (CD-ROM)	Y	-	Y	Y	Y	Y	1
7	Precautions for Printing Decal	Y	Y	Y	Y	Y	Y	1
8	EULA (Software license agreement sheet)	Y	Y	Y	Y	Y	Y	1
9	Brand plate	Y	Y	Y	-	-	Y	1
10	Exposure glass cleaning cloth	Y	Y	Y	Y	Y	Y	1
11	Pocket for exposure glass cleaning cloth	Y	Y	Y	Y	Y	Y	1
12	EU Safety Data Sheet	-	Y	-	-	-	-	1
13	Warranty (China)	-	-	-	Y	-	-	1
14	Power Cord	Y	Y	Y	Y	Y	Y	1
15	Model name decal	Y	Y	Y	-	-	Y	1
16	Sheet: TEL name (China)	-	-	-	Y	-	-	1
17	Function decal	Y	Y	Y	Y	Y	Y	1

No.	Description	-17	-27	-29	-21	-25	-19	Q'ty
18	Function decal (blank)	Y	Y	Y	Y	Y	Y	1
19	Toner cartridge	-	-	-	Y	-	-	1

2

Basic Models (D170)

No.	Description	-17	-27	-29	-21 -25	Q'ty
1	SMC report	Y	Y	Y	Y	1
2	EU Safety Data Sheet	-	Y	-	-	1
3	Sheet - EMC - Traceability	-	Y	-	-	1
4	Warranty (China)	-	-	-	Y	1
5	Warranty (China): Decal	-	-	-	Y	1
6	Caution Decals for ARDF	Y	Y	Y	Y	1
7	Function decal	Y	Y	Y	Y	1
8	Function decal (blank)	Y	Y	Y	Y	1
9	Model name plate	Y	Y	Y	-	1
10	CD-ROM: Driver	Y	Y	Y	Y	1
11	EULA (Software license agreement sheet)	Y	Y	Y	Y	1
12	Decal: CAUTION	Y	Y	Y	Y	1
13	Package: Developer	-	-	-	Y	1
14	Toner cartridge	-	-	-	Y	1
15	Power cord	Y	Y	Y	Y	1
16	Cover for transport lever	Y	Y	Y	Y	2
17	Decal: Environment symbol mark	-	-	-	Y	1
18	Energy saving mark (China)	-	-	-	Y	1

GDI Models (D160/D161)

No.	Description	-27	-29	-21 -25	Q'ty
1	SMC report	Y	Y	Y	1
2	EU Safety Data Sheet	Y	-	-	1
3	Sheet – EMC – Traceability	Y	-	-	1
4	Warranty (China)	-	-	Y	1
5	Warranty (China): Decal	-	-	Y	1
6	Caution Decals for ARDF	Y	Y	Y	1
7	Function decal	Y	Y	Y	1
8	Function decal (blank)	Y	Y	Y	1
9	Brand plate	Y	Y	-	1
10	CD-ROM: Driver	Y	Y	Y	1
11	EULA (Software license agreement sheet)	Y	Y	Y	1
12	Decal: CAUTION	Y	Y	Y	1
13	Package: Developer	-	-	Y	1
14	Toner cartridge	-	-	Y	1
15	Power Cord	Y	Y	Y	1
16	Decal: Environment symbol mark	-	-	Y	1
17	Energy saving mark (China)	-	-	Y	1

Installation Procedure

CAUTION

- Unplug the machine power cord before starting the following procedure.

1. Remove filament tape and other padding.

2



d1582002

2. Install the covers [A], [B].

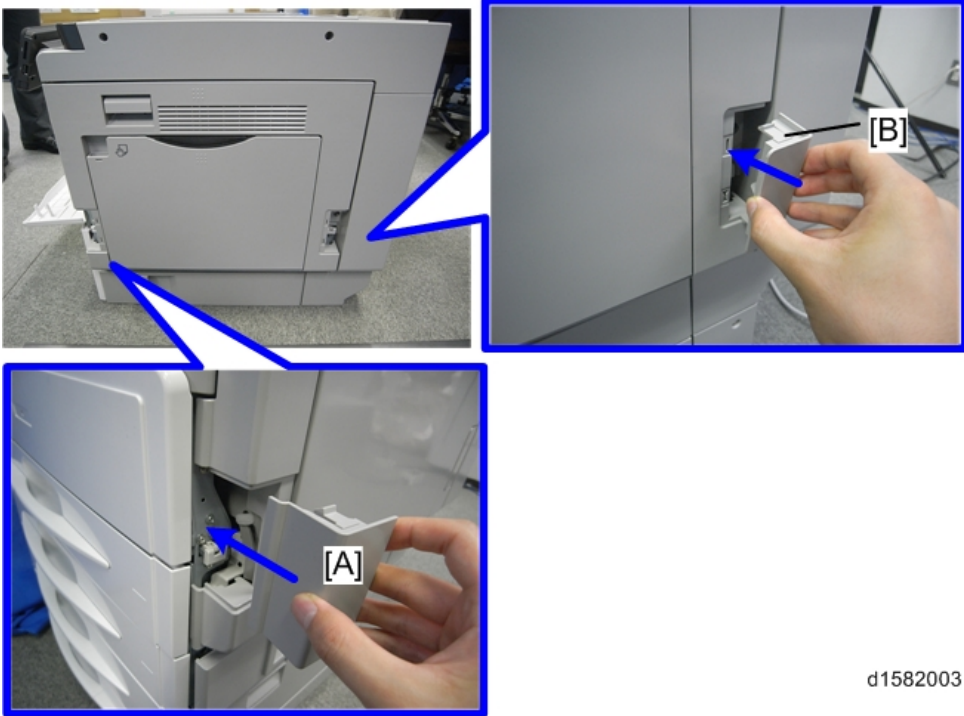

d1582003

3. Open the front door and remove the toner bottle holder [A].

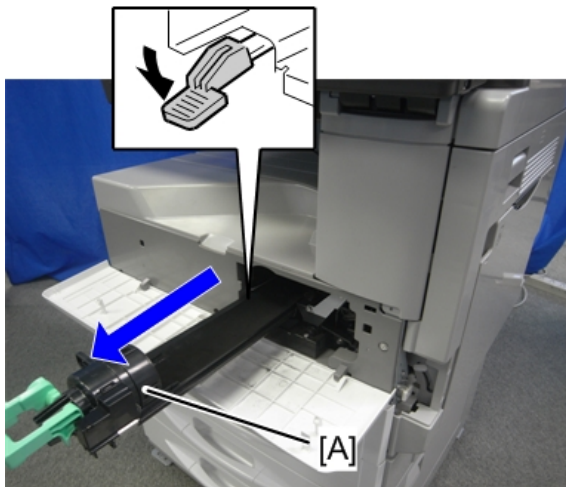

d1582108

4. Open the right door [B], and remove the PCU (photoconductor unit) [A].

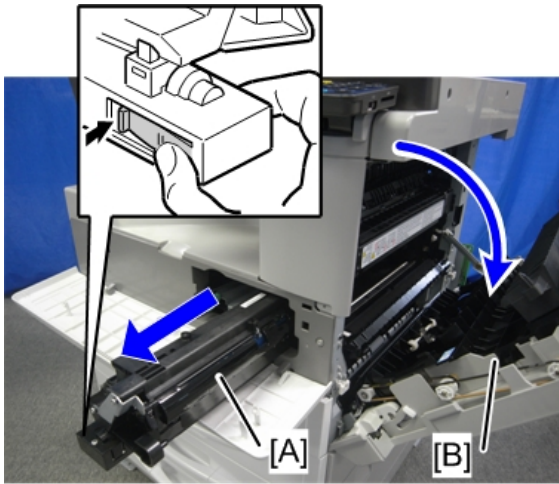

d1582109

5. Separate the PCU into the upper part and the lower part (⚙ x 5).
6. Put a sheet of paper on a level surface and place the upper part on it.

Note

- This prevents foreign material from getting on the sleeve rollers.

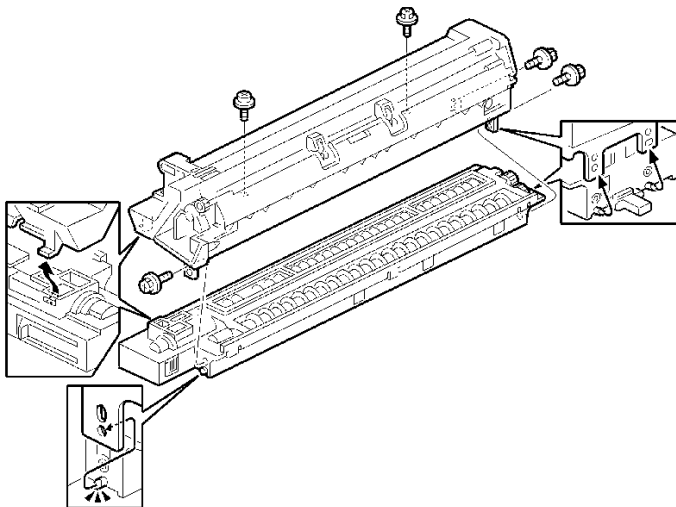

7. Distribute a pack of developer [D] to all openings equally.

Note

- Do not spill the developer on the gears [E]. If you have spilled it, remove the developer by using a magnet or magnetized screwdriver.
- Do not turn the gear [E] too much. The developer may spill.

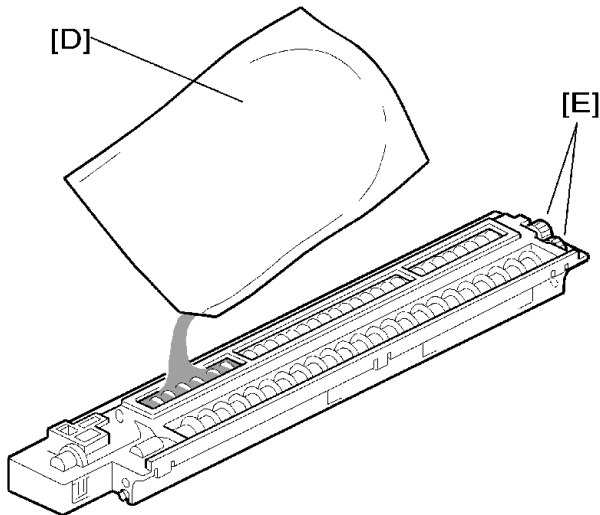

8. Reassemble the PCU and install it.
9. Shake the toner bottle [F] several times. (Do not remove the bottle cap [G] before you shake the bottle.)
10. Remove the bottle cap [G] and install the bottle on the holder. (Do not touch the inner cap [H].)

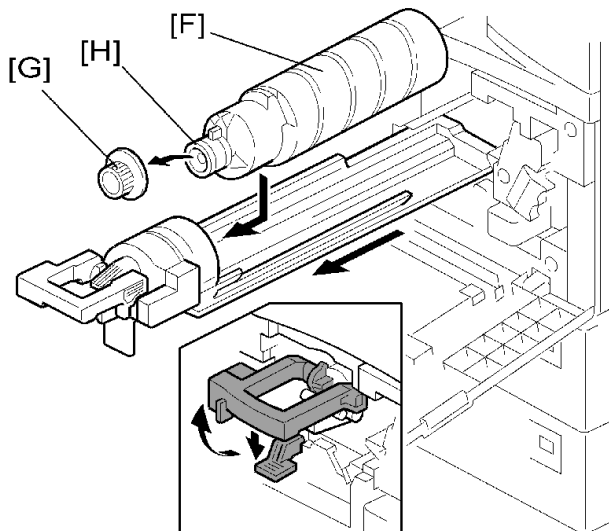

11. Set the holder (with the toner bottle) in the machine.

12. Pull out the paper tray [A], and then adjust the positions of the end and side guides (1 x 1).

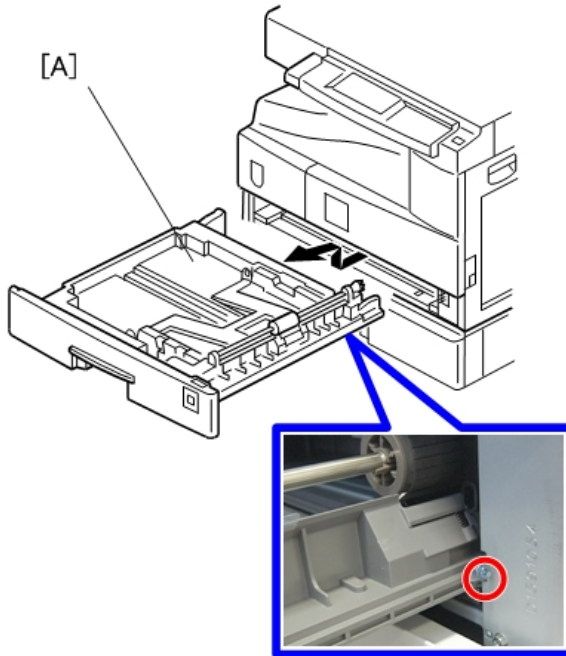

d1585051

Note

- To move the side guides, release the green lock on the rear side guide.

13. Install the optional ARDF, or platen cover.
14. Plug in the main power cord and turn on the main switch.
15. Activate the SP mode and execute "Developer Initialization" (SP2-801-001).
16. Wait until the message "Completed" shows (about 20 seconds).
17. Activate the User Tools and select the "Language" menu.
18. Specify a language. This language is used for the operation panel.
19. Load the paper in the paper tray and make a full size copy, and make sure the side-to-side and leading edge registrations are correct.

Selecting the Panel Display Language (for D158/D159)

To change the panel display language, it is necessary to register available languages in the User Tools. Specify the settings according to the following procedure.

Note

- You can select one of these languages (the default is English): Japanese, English, German, French, Italian, Dutch, Swedish, Norwegian, Danish, Spanish, Finnish, Portuguese, Czech, Polish, Hungarian, Simplified Chinese, Russian, Greek, Catalan, Turkish, or Brazilian Portuguese.
- You do not have to do this procedure if you use English. Do this procedure if you want to use a different language.

1. Turn on the power switch of the machine.
2. Press the "User Tools/Counter" key.
3. Press "Administrator Tools" in "System Settings".
4. Press "Select Switchable Languages".
5. Using the language button displayed on the User Tools screen, select the required language (this will then be selectable at any time with a toggle setting), and then press "OK".

Note

- Only languages available for the machine are displayed.
 - At least one language must be selected.
6. Return to the User Tools menu, and then keep pressing the language button until the language you want to select appears.

Note

- The language selected in "Select Switchable Languages" becomes available for selection by a toggle setting.

Shutdown/Forced Shutdown Functions

Shutdown Function

To protect the hard drive from damage if the power fails while the drive is being written to, the machine has a shutdown function. If the main power switch is turned off, the machine shuts down safely by ensuring the following:

- Corruption of files on the system hard drive, in the NAND flash memory, and on an SD card or USB flash drive is prevented.
- Loss of main power while paper (except jammed paper) is still in the machine is prevented.
- All job and access logs are saved.

Shutdown message

The following message appears during shutdown:

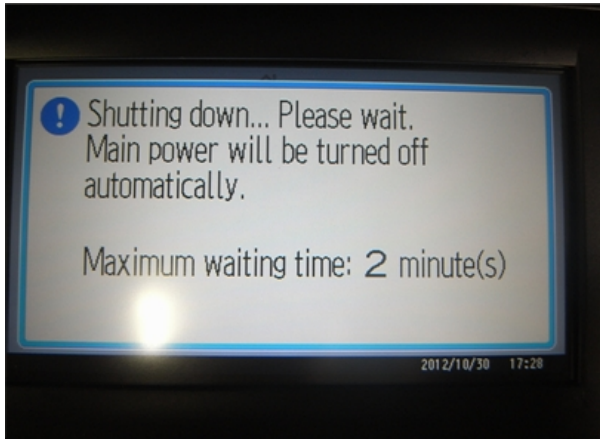

d1582236

The shutdown message does not appear in the following cases:

- If the main power goes off suddenly
- If the main power switch is turned off when the controller is off
- If the main power switch is turned off during a special operation such as deleting all data on the hard disk, updating firmware, encrypting data on the hard disk, or detecting changes to the device configuration
- If the main power switch is turned off during a reboot

Do not turn the main power switch on just after turning it to Standby. If the message "Turn main Power Switch off" appears, turn the main power switch to standby, wait for at least ten seconds, and then turn it back on.

Forced Shutdown Function

You can forcibly turn the main power off by holding down the main power switch for more than 6 seconds.

★ Important

- Pressing the main power switch starts the shutdown process, during which the shutdown message appears. Be careful not to forcibly turn the main power off before shutdown is complete. Doing so may cause loss of data.
- The Forced Shutdown function is a fail-safe that lets you turn the main power off without unplugging the power cord if the machine has not shut down despite having had enough time to do so. Do not use Forced Shutdown excessively. Also, be careful not to hold the main power switch down by mistake.

Instructions for the Customers

The following items should be advised when the machine is installed. These items are explained in more detail in the operating instructions.

How to add paper to the paper feed unit and the by-pass feed unit.

How to install a toner bottle

How to handle paper jams

How to feed thin paper using the ARDF (for D158/D159) (p.43 "ARDF Installation (for D158/D159)")

Platen Cover Installation

Accessory Check

Check that you have the accessories indicated below.

2

No.	Description	Q'ty
1	Platen Cover	1
2	Platen Sheet	1
3	Feeler Guide	1
4	Stepped Screw	2

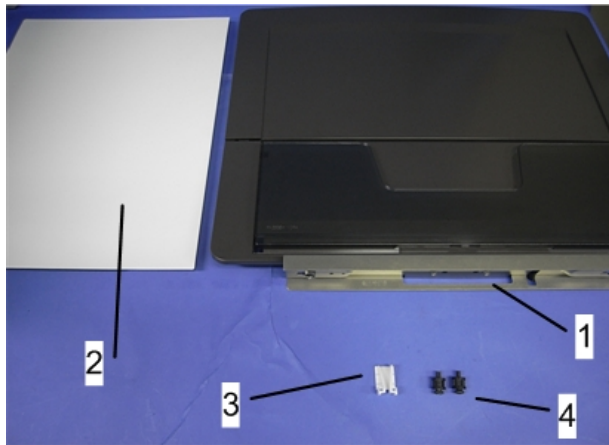

d1582018

Installation Procedure

⚠ CAUTION

- Unplug the machine power cord before starting the following procedure.

1. Install the stepped screws (🔩 x 2).

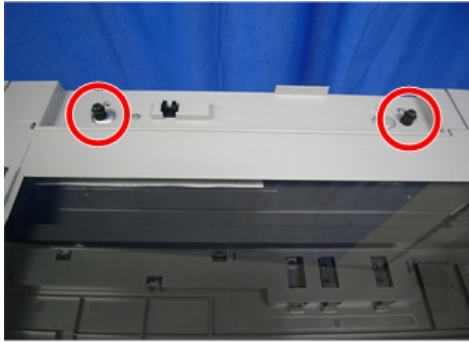

d1582019

2. Install the feeler guide [A].

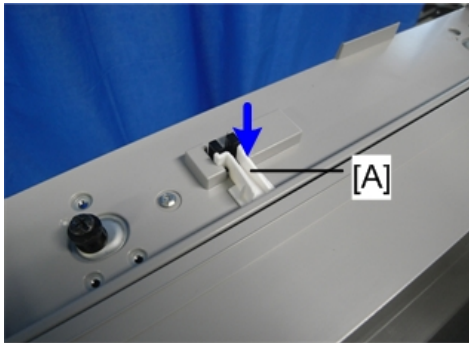

d1582020

3. Install the platen cover [A].

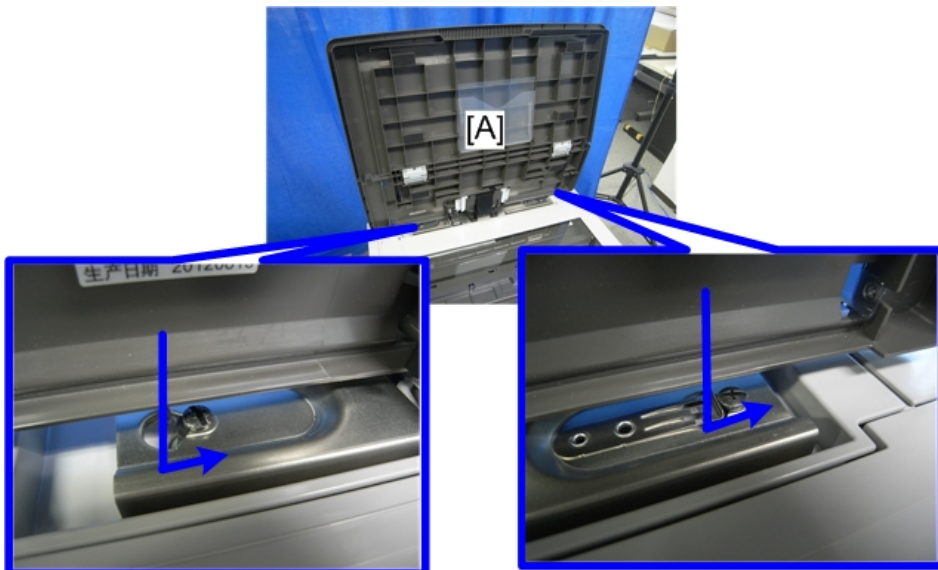

d1582021

4. Place the platen sheet [A] on the exposure glass.

5. Line up the rear left corner of the platen sheet flush against corner [B] on the exposure glass.

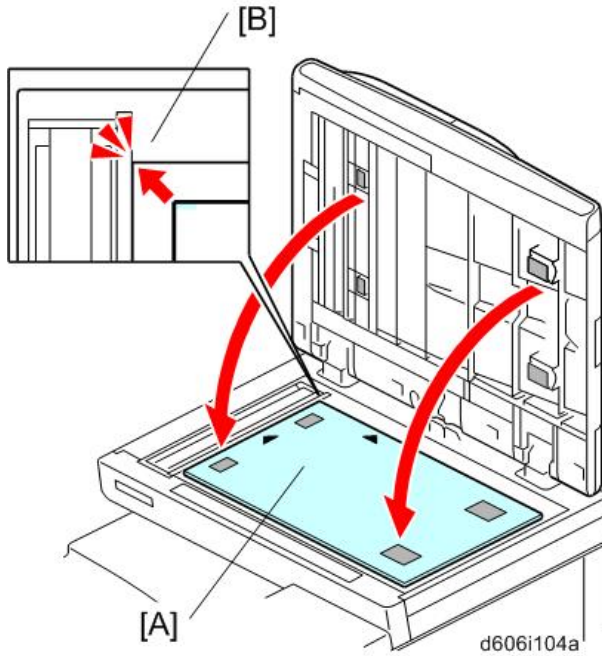

6. Close the platen cover.
7. Open the platen cover.
8. Press the surface of the platen sheet gently to fix it on the platen cover securely.

ARDF Installation (for D158/D159)

Accessory Check

Check the quantity and condition of the accessories against the following list.

No.	Description	Q'ty
1	ARDF	1
2	Screw	2
3	Knob Screw	2
4	Stud Screw (Small)	1
5	Stud Screw (Large)	1
6	Attention Decal – Top Cover	1
-	Installation Procedure	1

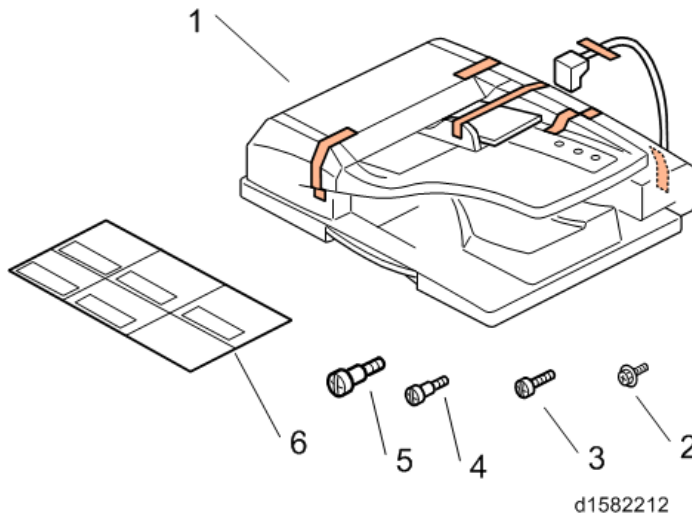

Installation Procedure

⚠ CAUTION

- Unplug the copier power cord before starting the following procedure.

1. All tapes and shipping retainers.
2. Insert the two stud screws ([A] is the larger stud, [B] is the smaller stud).

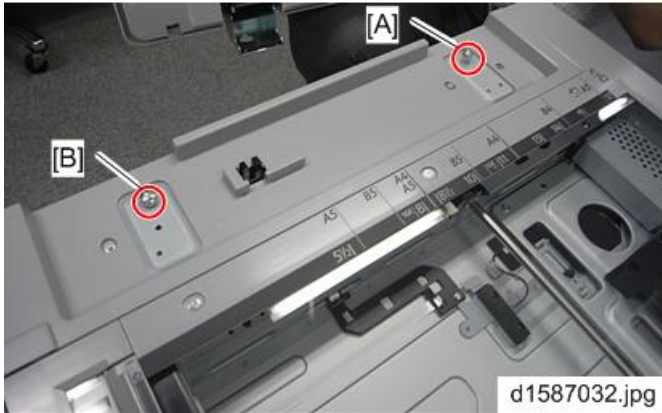

3. Mount the ARDF [A] by aligning the screw keyholes [B] of the ARDF support plate over the stud screws.
4. Slide the ARDF toward the front of the machine.
5. Secure the ARDF with the two knob screws [C].

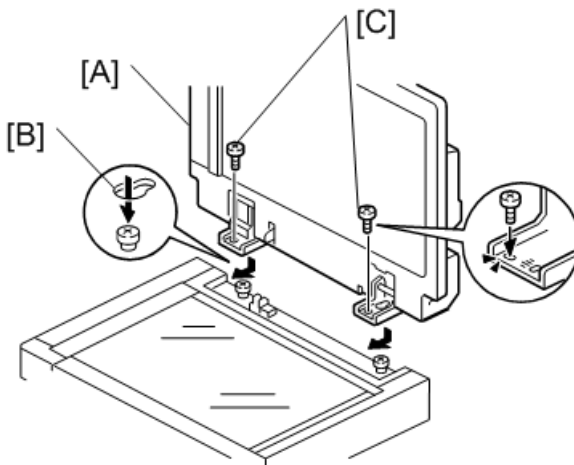

b789i103a

6. Align the rear left corner of the platen sheet [A] with the corner [B] on the exposure glass.
7. Close the ARDF.
8. Open the ARDF and check that the platen sheet is correctly attached.

[RTB 37](#)
[Replace the mylar with a new type](#)

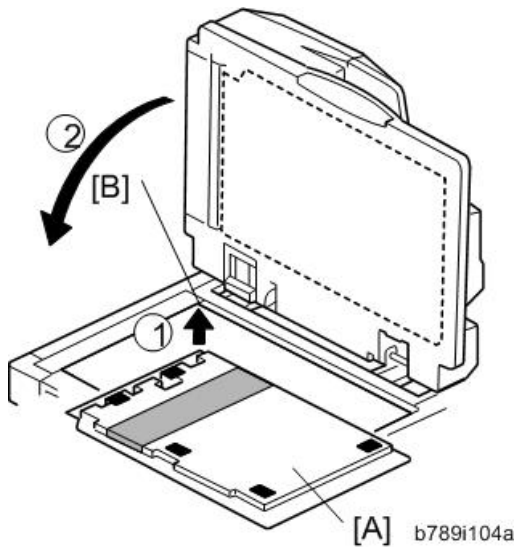

9. Lift the ARDF original tray.
10. Slide the stamp holder [A] out and install the stamp cartridge in it, if necessary.

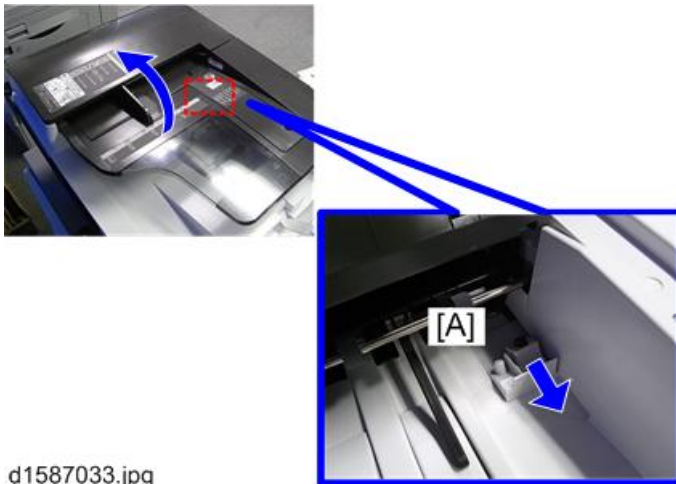

d1587033.jpg

Note

- After the stamp installation, be sure to slide the holder in correctly. If not, jam detection (J001) will occur.

11. Attach the decal [A] to the top cover as shown. Choose the language that you want.

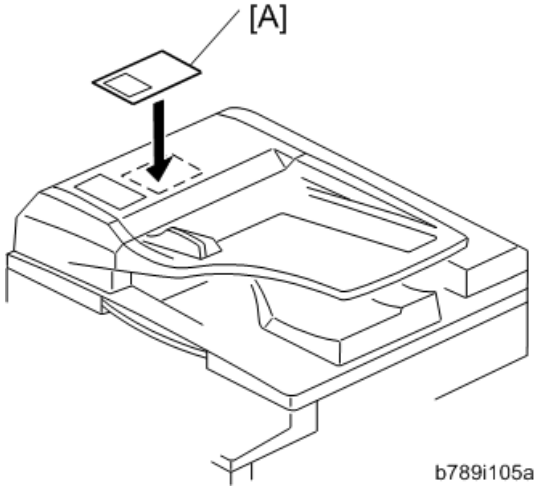

12. Rear Cover [A] (🔧 x9)

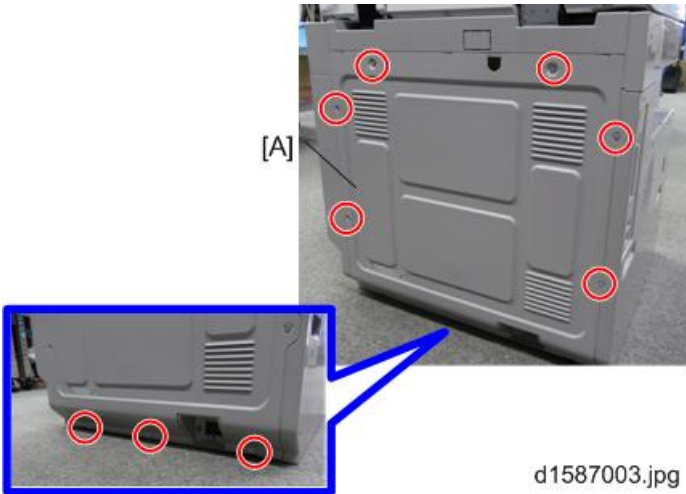

13. Cut away the knockout [A].

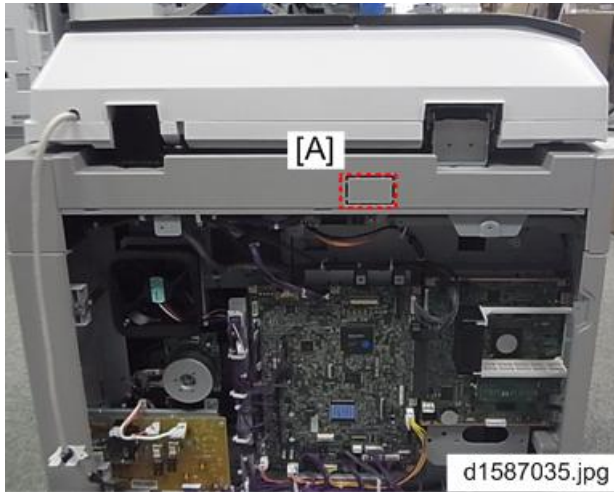

14. Attach the harness bracket as shown [A]. (⚙️ x1)
15. Connect the end of the cable [B].

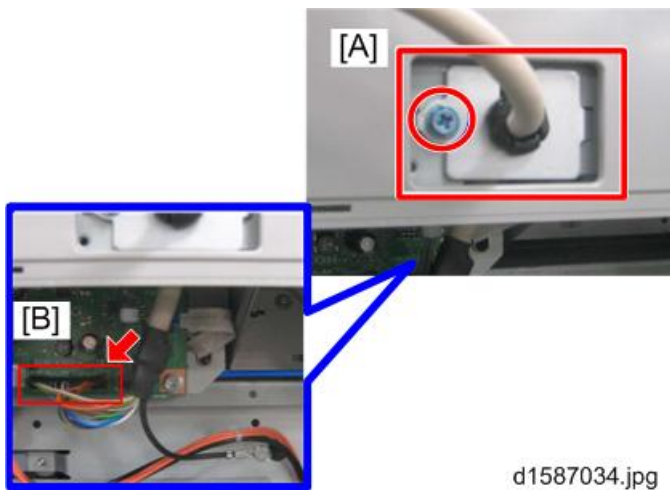

16. Fasten the grounding wire [A] as shown. (⚙️ x1)

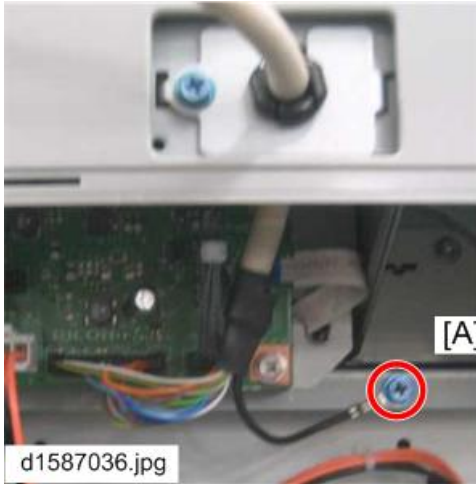

17. Plug in and turn on the main power switch of the machine, and then check the ARDF operation.
18. Make a full size copy. Check that the registrations (side-to-side and leading edge) and image skew are correct. If they are not, adjust the registrations and image skew (see p.263 "ARDF Image Adjustment" in the "Replacements and Adjustments" chapter).

When feeding thin paper

When feeding thin paper, adjust the sliding tray to the point shown below [A].

When feeding normal paper, adjust the sliding tray to the point shown below [B].

If not, it may cause problems as follows;

- Original jam
- Original curl
- Originals cannot be stacked neatly

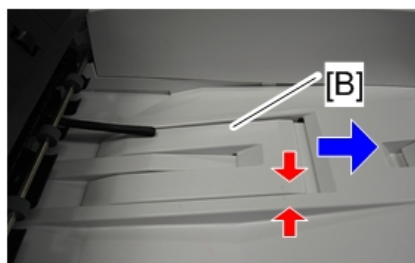
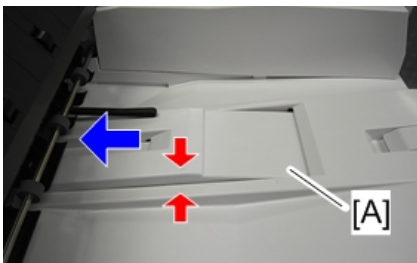

d1585055

ARDF Installation (for D160/D161/D170)

Accessory Check

Check the quantity and condition of the components against the following list.

No.	Description	Q'ty
1	ARDF	1
2	Screw	2
3	Knob Screw	2
4	Stud Screw	2
5	Attention Decal – Top Cover	1
6	Clamp	3
-	Installation Procedure	1

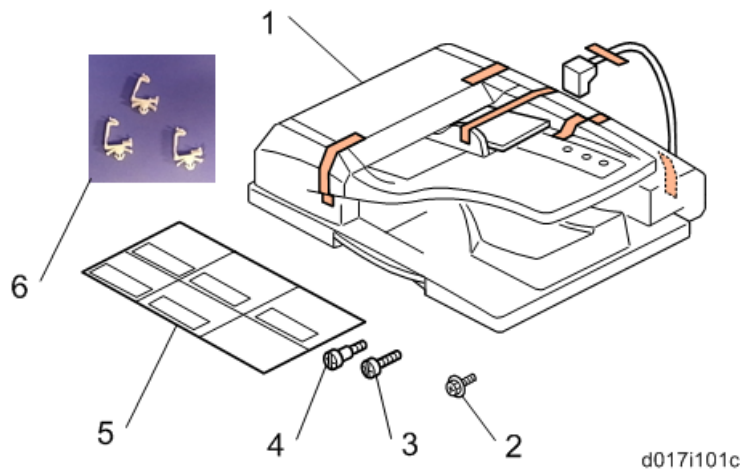

Installation Procedure

⚠ CAUTION

- Unplug the copier power cord before starting the following procedure.

1. All tapes and shipping retainers.

2. Insert the two stud screws [A] [B].

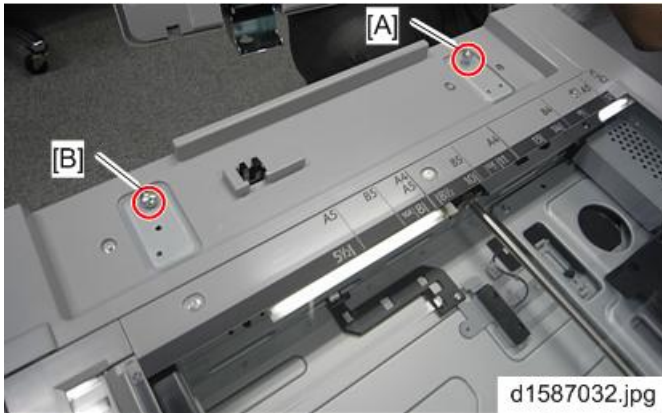

3. Mount the ARDF [A] by aligning the screw keyholes [B] of the ARDF support plate over the stud screws.
4. Slide the ARDF toward the front of the machine.
5. Secure the ARDF with the two knob screws [C].

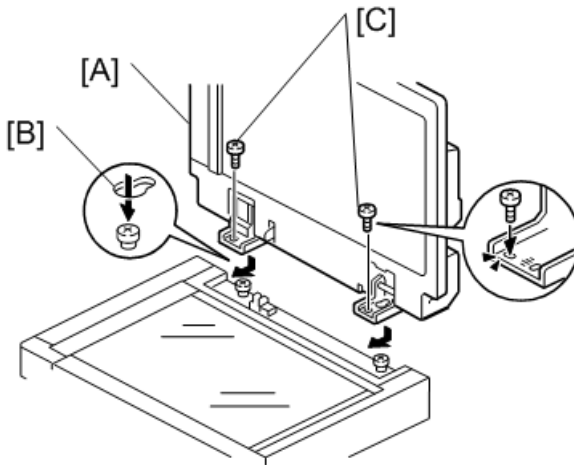

b789i103a

6. Align the rear left corner of the platen sheet [A] with the corner [B] on the exposure glass.
7. Close the ARDF.
8. Open the ARDF and check that the platen sheet is correctly attached.

RTB 37
Replace the mylar with a new type.

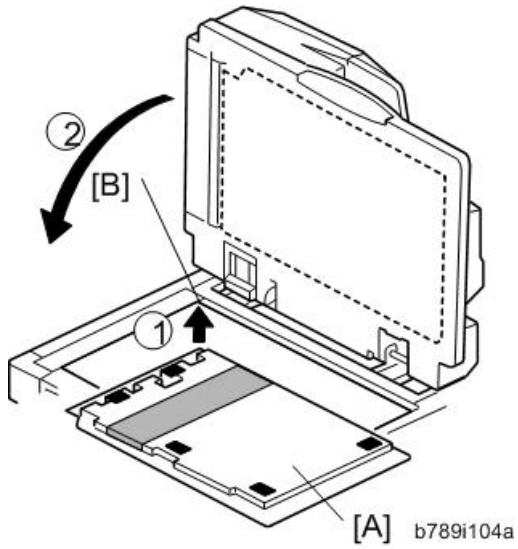

9. Attach the decal [A] to the top cover as shown. Choose the language that you want.

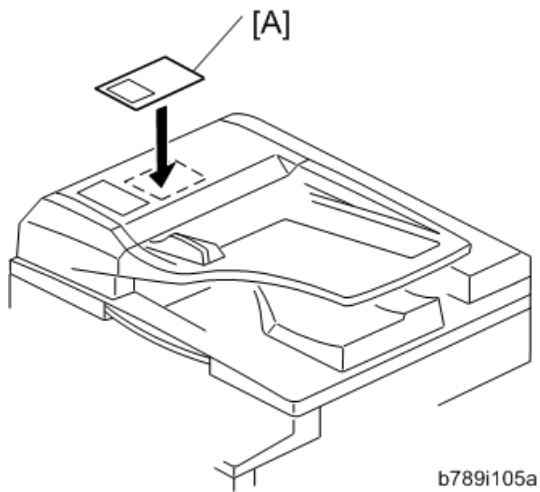

10. Rear Cover [A] (🔩 x9)



d1587037.jpg

11. Cut away the knockout [A].

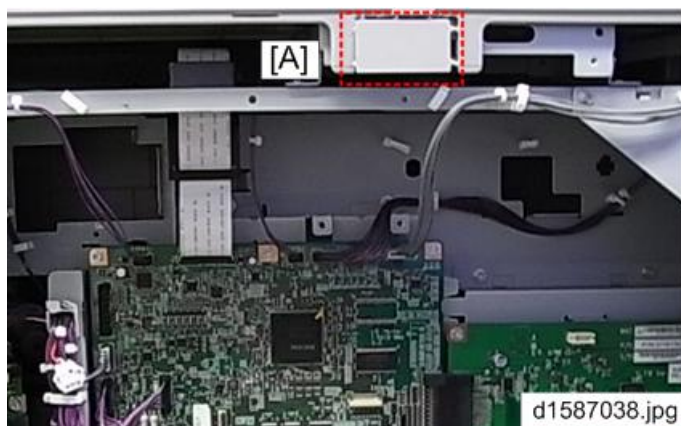

d1587038.jpg

12. Attach the harness bracket [A]. (⚙️ x1)

13. Set the cable and fix it with clamps as shown [B].

14. Connect the end of the cable to the engine board [C].

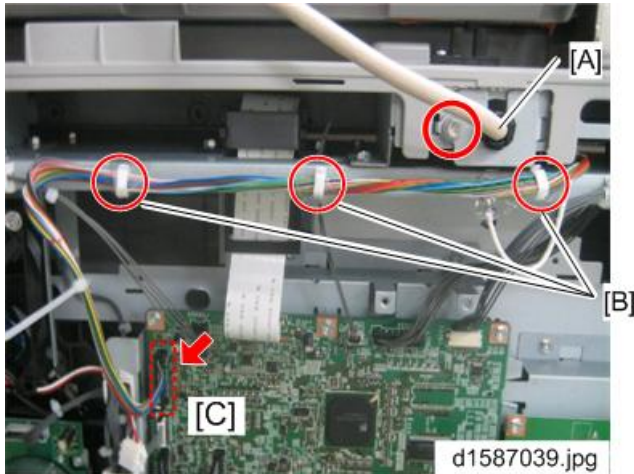

15. Fasten the grounding wire [A] as shown. (⚙️ x1)

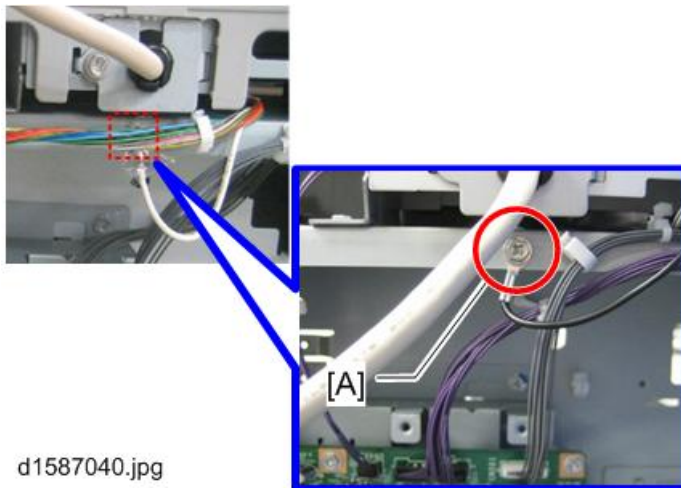

16. Plug in and turn on the main power switch of the machine, and then check the ARDF operation.
17. Make a full size copy. Check that the registrations (side-to-side and leading edge) and image skew are correct. If they are not, adjust the registrations and image skew (see p.263 "ARDF Image Adjustment" in the "Replacements and Adjustments" chapter).

Two-tray Paper Tray Unit Installation

Accessory Check

Check the quantity and condition of the accessories against the following list.

No.	Description	Q'ty
1	Paper Feed Unit	1
2	Paper Tray Number Decal	1
3	Securing Bracket	2
4	Screw	4
-	Installation Procedure	1

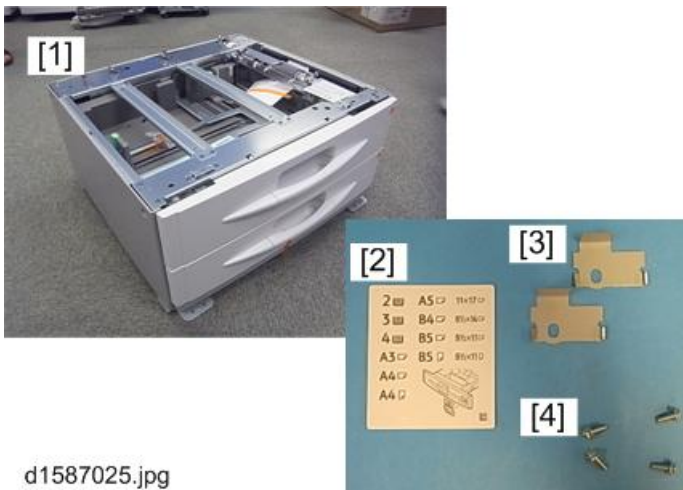

Installation Procedure

⚠ CAUTION

- Unplug the machine power cord before starting the following procedure.
- The handles of the main machine for lifting must be inserted inside the machine and locked, unless these handles are used for the installation or relocation of the main machine.
- You need two or more persons to lift the copier. The copier is highly unstable when lifted by one person, and may cause human injury or property damage.

- Do not remove the anti-tip components at the bottom of the unit
1. All strips of tape and accessories on the paper feed unit
 2. Rear Cover [A] (🔩 x 9)

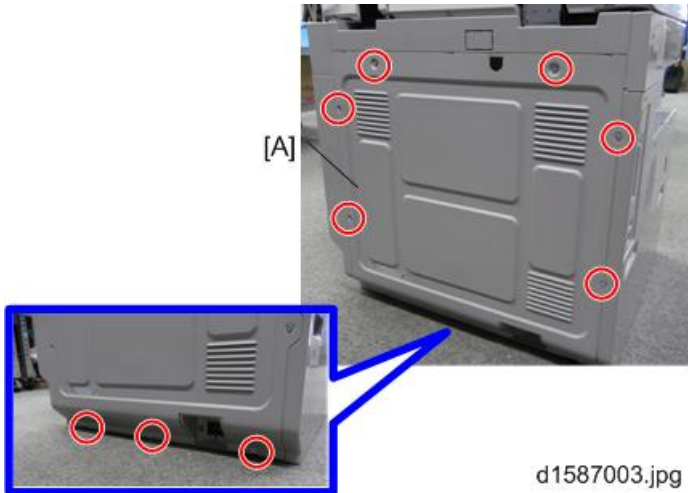

3. Set the copier [A] on the paper feed unit [B].

Note

- When installing the copier, be careful not to pinch the cable [C].
- Be sure to insert the basing pins [D] into the basing holes at the bottom of the main machine.
- Lead the cable out [C] as shown below.

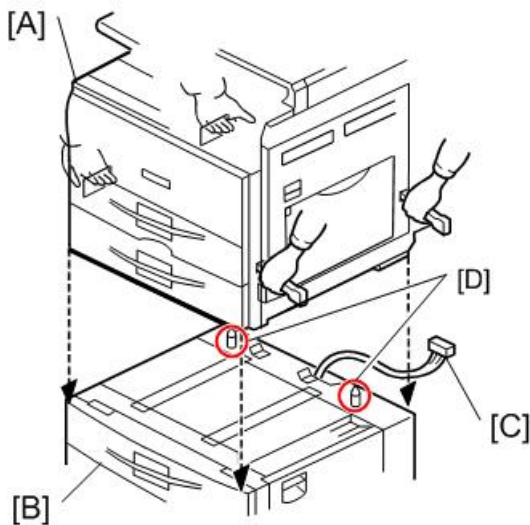

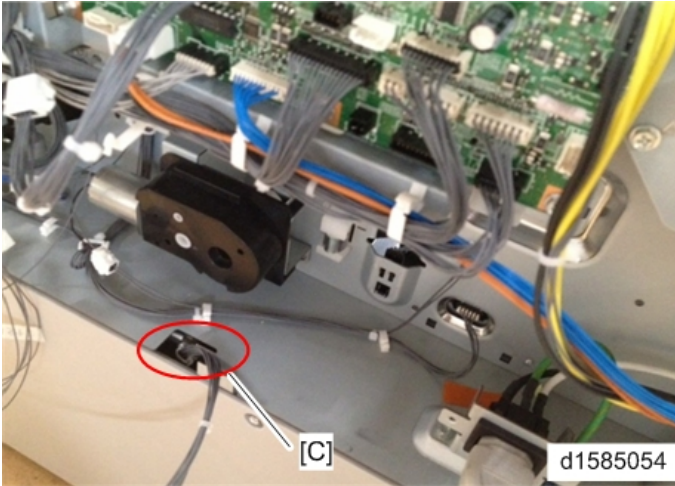

4. Connect the paper feed unit cable [A] to the engine board [B], as shown.

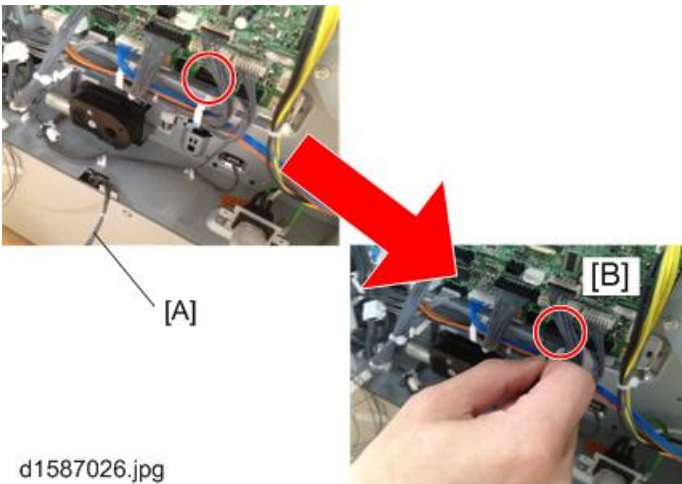

5. Attach the securing brackets [A] to both sides, as shown (1 x 1 each).

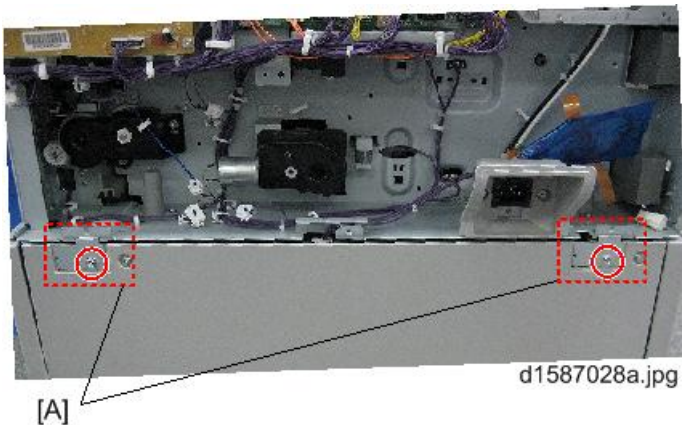

6. Remove the 1st and 2nd paper trays
7. Secure the paper feed unit with two screws [A] (2 x 2).
8. Reinstall all the paper trays.
9. Attach the appropriate paper tray number decal and paper size decal to each handle of the trays.

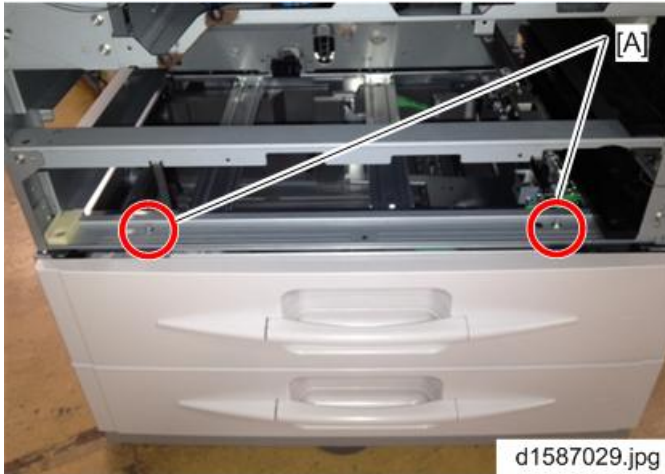

10. Rotate the adjuster [A] until the machine cannot be pushed across the floor.

d1587030.jpg



11. Load paper into the paper trays and select the proper paper size.
12. Turn on the main switch.
13. Adjust the registration for each tray (☛ p.258 "Copy Adjustments Printing/Scanning").
 - For tray 3, use SP1-002-004
 - For tray 4, use SP1-002-005
14. Check the machine's operation and copy quality.

One-tray Paper Tray Unit Installation

Component Check

Check the quantity and condition of the accessories against the following list.

No.	Description	Q'ty
1	Paper Feed Unit	1
2	Paper Tray Number Decal	1
3	Securing bracket	2
4	Screw	4
-	Installation Procedure	1

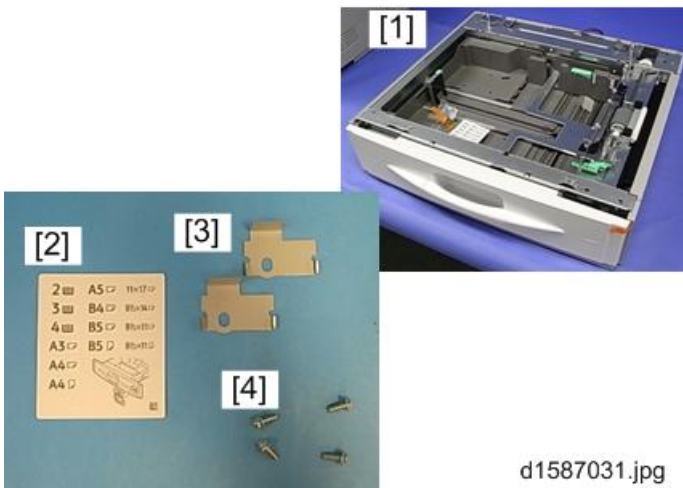

Installation Procedure

⚠ CAUTION

- Turn off the main switch of the copier and unplug the power cord before you start the installation procedure.
- You need two or more persons to lift the copier. The copier is highly unstable when lifted by one person, and may cause human injury or property damage.
- Do not lift the copier with the paper feed unit installed. The handle and grips may be damaged.

1. All tape on the paper feed unit.
2. Rear Cover [A] (🔩 x 9)

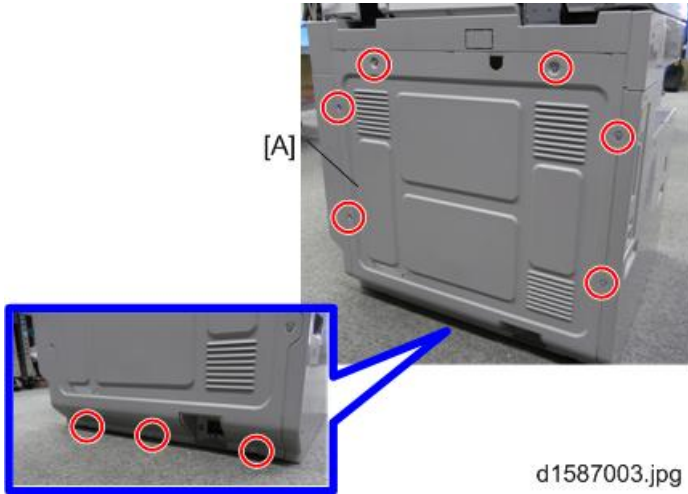

3. Lift the copier [A] and install it on the paper feed unit [B].

Note

- When installing the copier, be careful not to pinch the cable [C].
- Be sure to insert the basing pins [D] into the basing holes at the bottom of the main machine.
- Lead the cable out [C] as shown below.

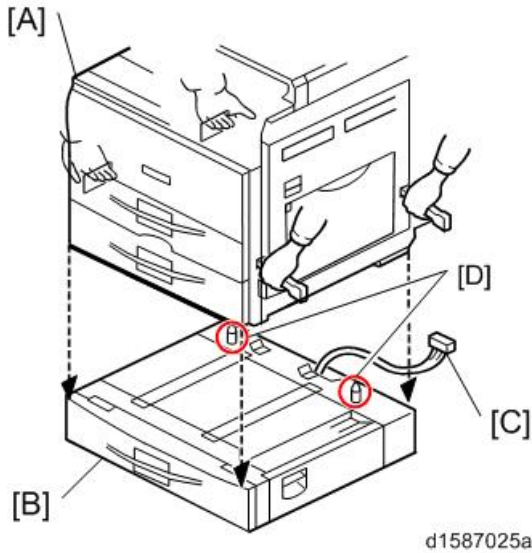

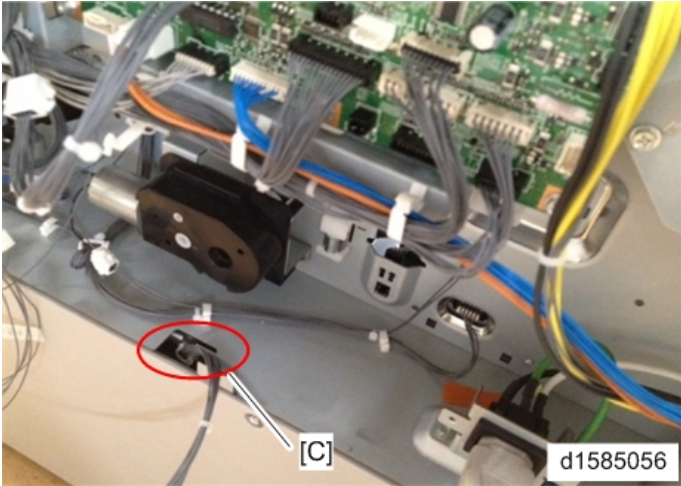

4. Connect the paper feed unit cable [A] to the engine board [B], as shown.

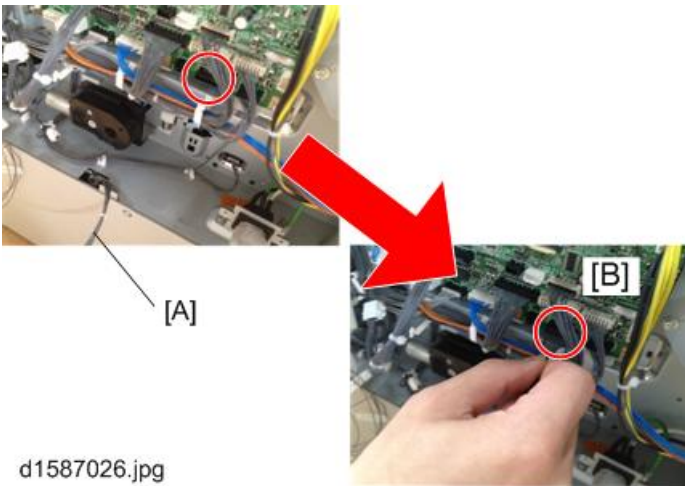

5. Attach the securing brackets [A] to both sides, as shown (1 x 1 each).

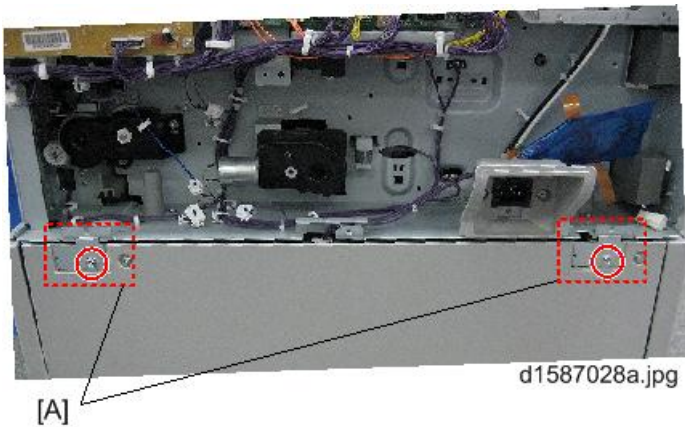

6. Remove tray 1 and 2 of the machine.
7. Secure the paper tray unit with two screws [A] (🔩 x 2).

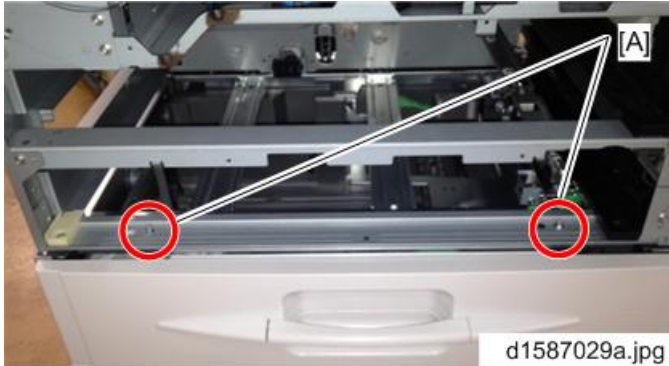

8. Reinstall all trays.
9. Load paper into the paper feed unit.
10. Turn on the main power switch of the machine.
11. Adjust the registration for each tray (🔧 p.258).
 - Use SP1-002-004
12. Check the paper feed unit operation and copy quality.

One-Bin Tray Installation

Component Check

Check the quantity and condition of the components against the following list.

2

No.	Description	Q'ty
1	1-Bin Tray Unit	1
2	Accessory Inner Tray	1
3	Tray	1
4	I/F Harness	1
5	LED Relay Harness	1
6	Screw	1
7	Clamp	1
8	Bracket	1
-	Installation Procedure	1

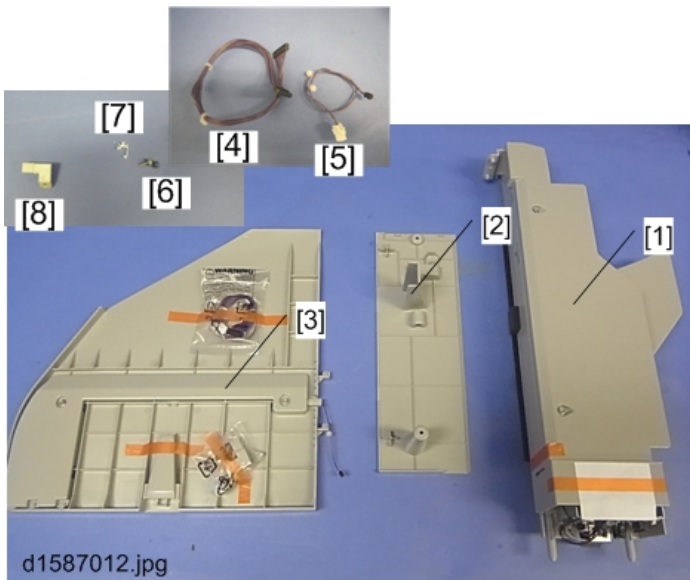

Installation Procedure

⚠ CAUTION

RTB 30
Important notes for installation

- Unplug the copier power cord before starting the following procedure.
1. Strip all tapes on the 1-bin tray unit off.
 2. Rear cover [A] (🔩 x 9)

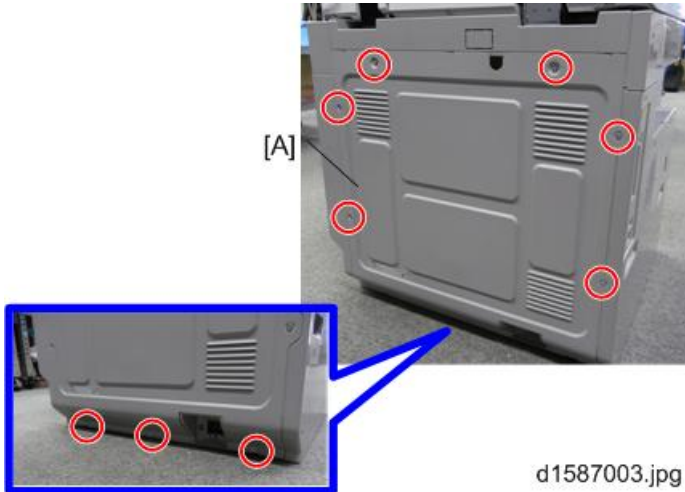

3. Inverter tray [A] (hook).



4. Inner cover [A] (🔩 x 2)

⚠ Note

- Keep the two screws that you removed in this step. Use them to attach the accessory inner cover (step 9).



d1587014.jpg

5. Open the right door [A] of the machine.
6. Front right cover [B] (⚙ x 1, hook).

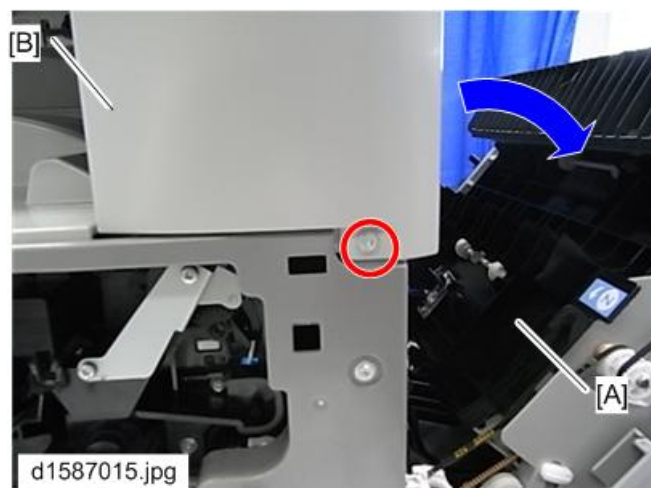

d1587015.jpg

7. Cut away the knockout from the front right cover.



8. Install the 1-bin tray unit [A] (1 x 1).

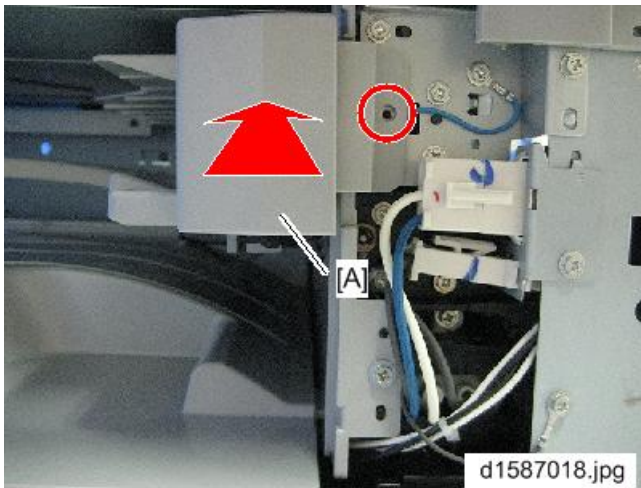

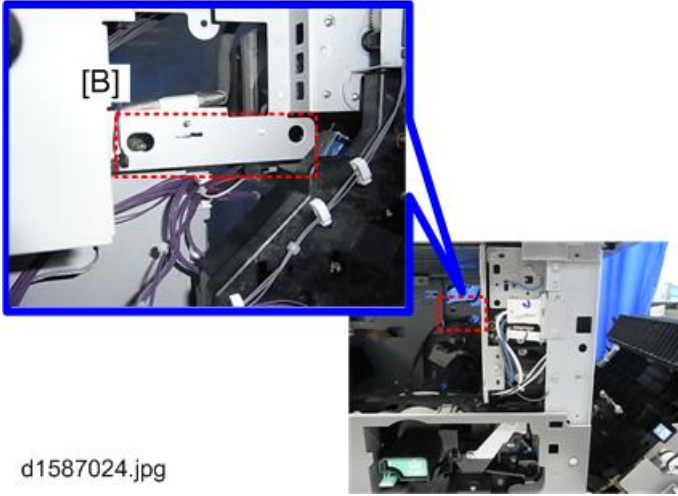

Note

- Be sure to insert the two points on the back of the unit into the frame holes [B].

9. Install the accessory inner cover [A] (⚙ x 2).

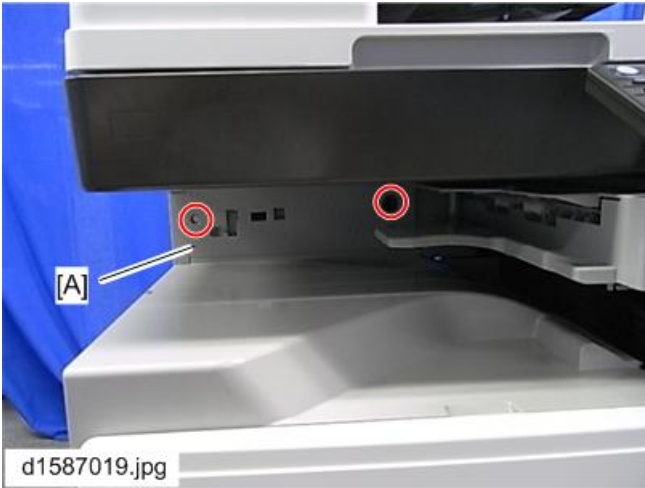

Note

- To attach the accessory inner cover [A], use the two screws removed in step.4.

10. Install the tray [A] in the machine as shown.

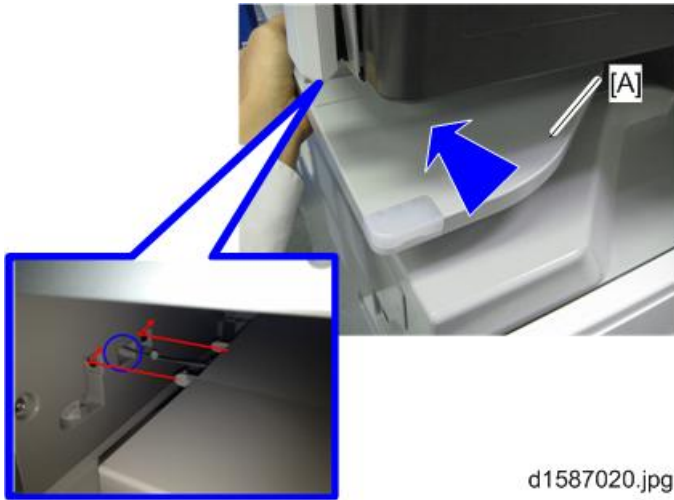

11. Be sure to pass the tray harness [B] through the inner cover opening [C] to the rear.

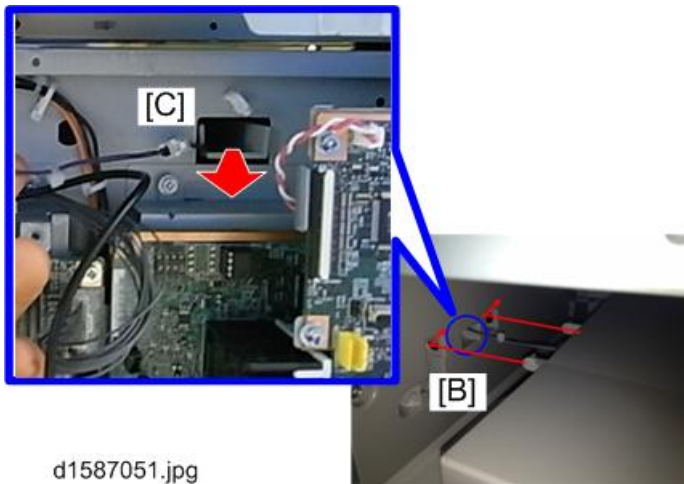

12. Attach the bracket [A] to fix the tray (🔩 x 1).

RTB 1
Cannot tighten the screw

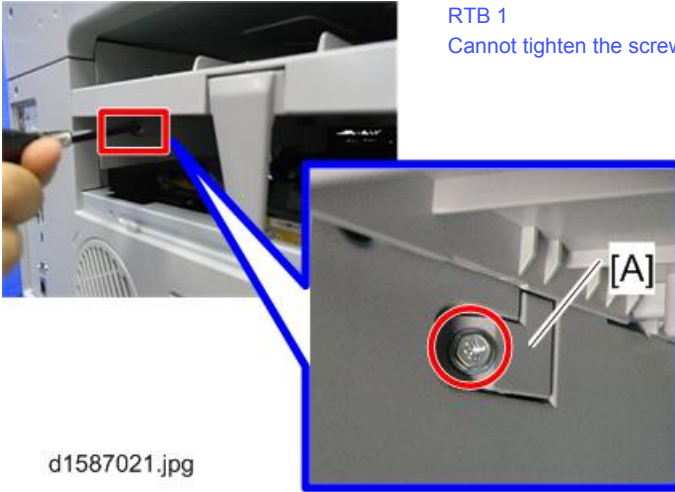

d1587021.jpg

Note

- Facing the left side of the machine, the screw is fastened at an angle.

13. With the accessory harness, connect the 1-bin tray unit board [A] and the tray harness [B] on the rear side.
14. Attach the clamp [C] and secure the harness as shown.

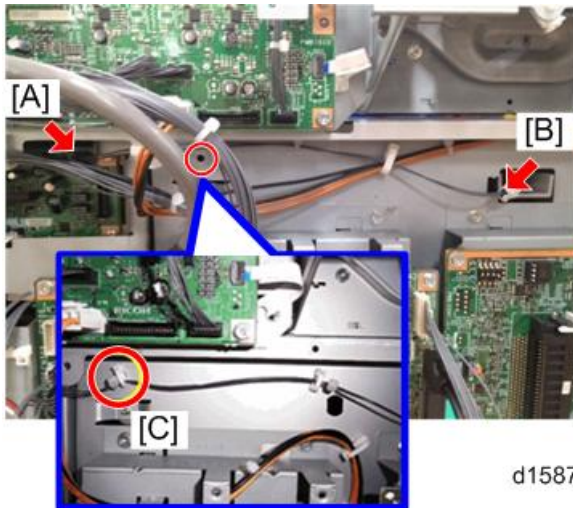

d1587022.jpg

15. Connect the 1-bin tray unit board [A] and the engine board [B] with the cable harness.

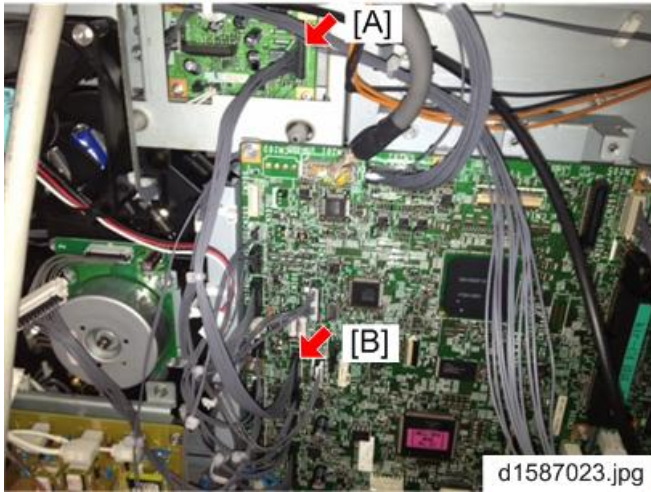

16. Reassemble the machine.

17. Turn on the main power switch of the machine, and check the 1-bin tray unit operation.

18. Make sure the LED as shown below [A] is ON.

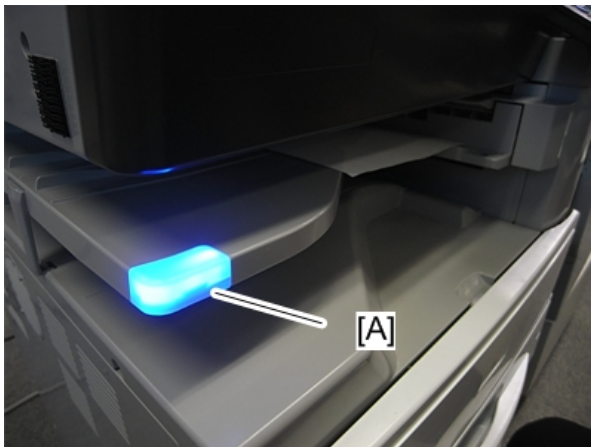

d1585057

Anti-condensation Heater Installation

Component Check

Check the quantity and condition of the components against the following list.

No.	Description	Q'ty
1	Anti-condensation Heater	1
2	Relay Harness	1
3	Bracket	1
4	Screw	2

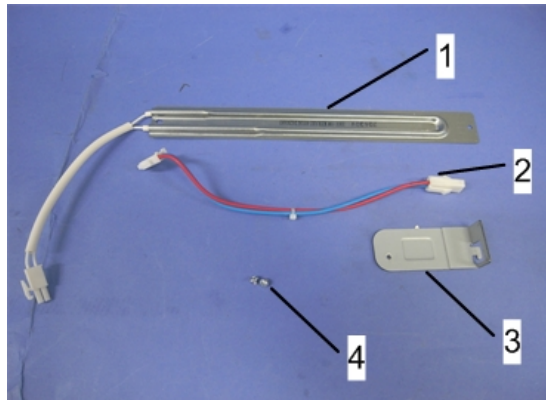

d1582215

Installation Procedure

⚠ CAUTION

- Unplug the machine power cord before starting the following procedure.

1. Rear cover (☛ p.152)
2. Platen cover, or ARDF (if installed)
3. Exposure glass/DF exposure glass (☛ p.166)

4. Install the bracket [A].

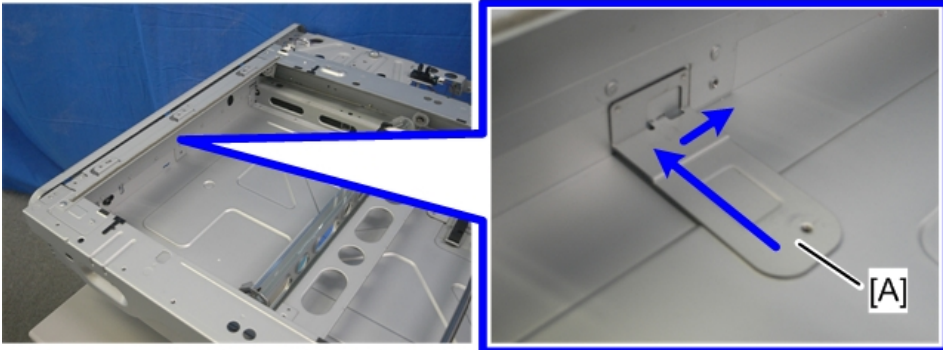

d1582173

5. Install the anti-condensation heater [A] (2 x).

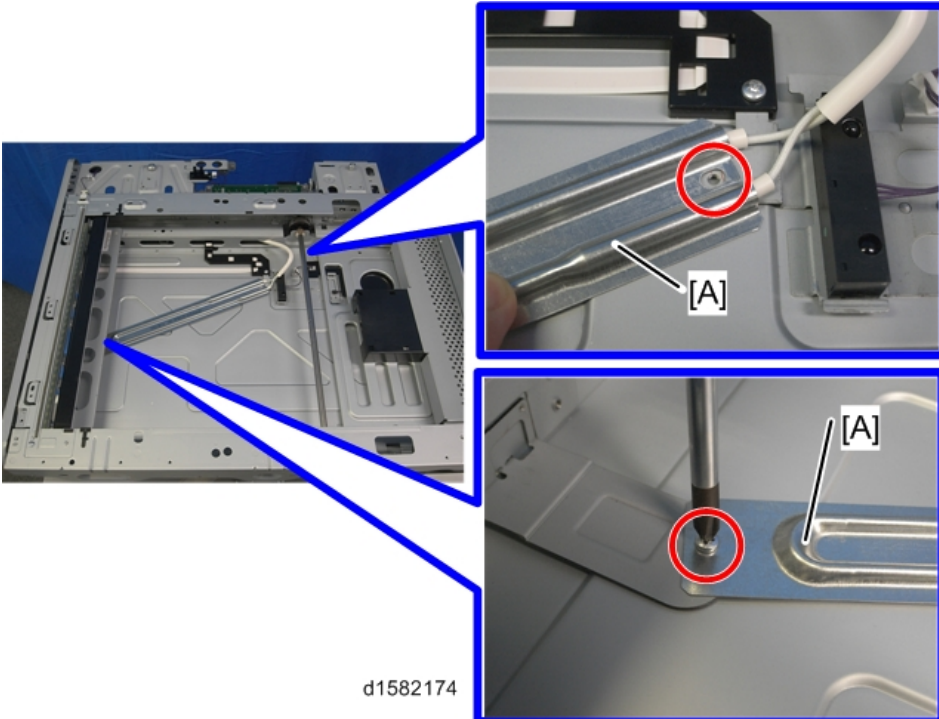

d1582174

6. Pass the connector [A] as shown below.

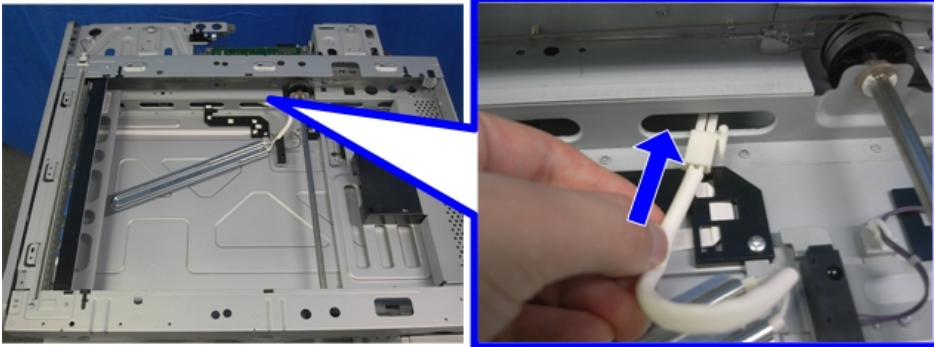

d1582175

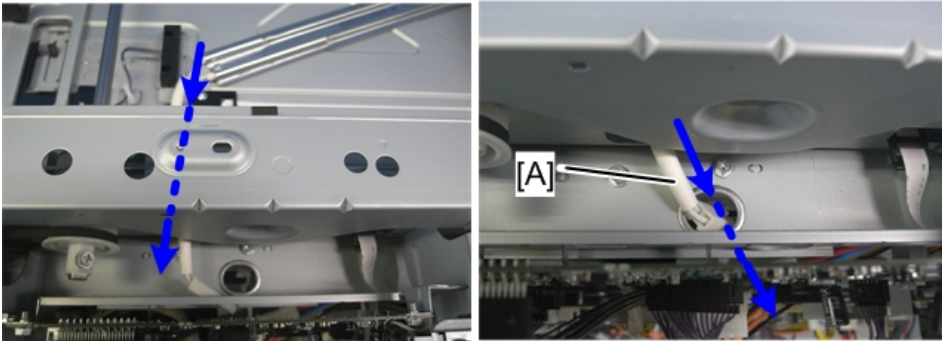

d1582176

7. Connect the harness [B] to [C].

8. Join the connectors [A] [B] (🔍 x 2).

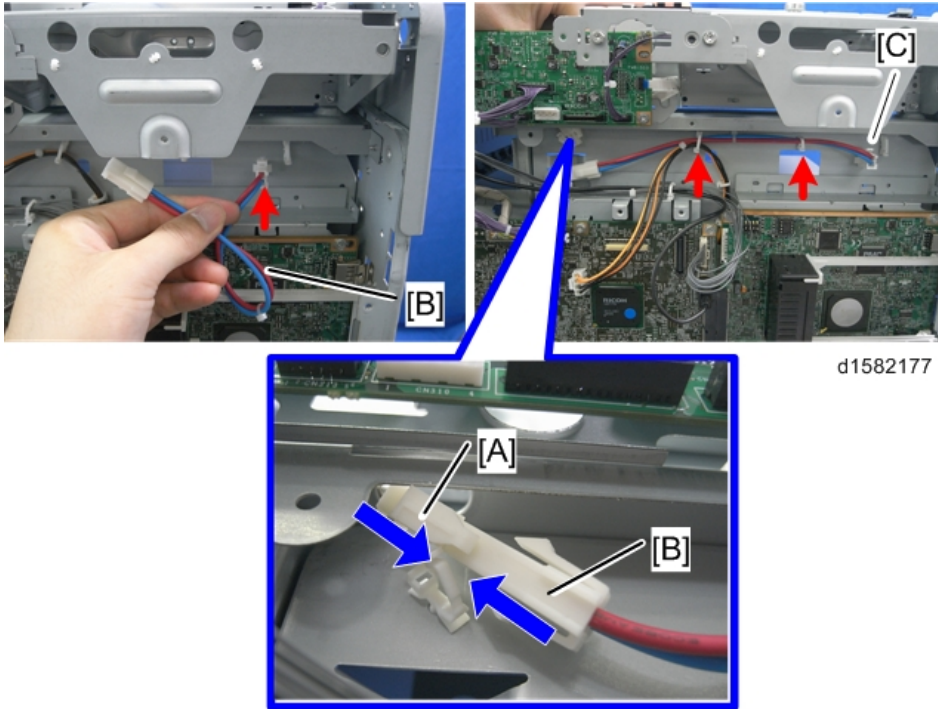

9. Install the harness of the heater and connect it to the PSU. (🔍 p.90 "Installing the Harness of the Heater")

Tray Heaters

⚠ CAUTION

- Unplug the machine power cord before starting the following procedures.

2

Mainframe Upper Tray Heater

★ Important

- Unplug the machine power cord before starting the following procedure.

Component Check

Check the quantity and condition of the components against the following list.

No.	Description	Q'ty
1	Heater	1
2	Screw	1

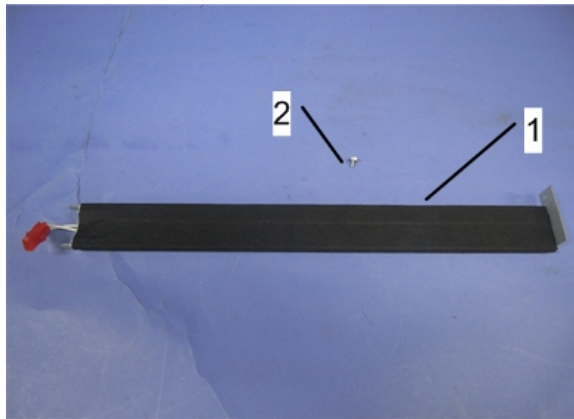

d1582216

Installation Procedure

1. 1st Tray Cassette [A] (⌀ x 1)

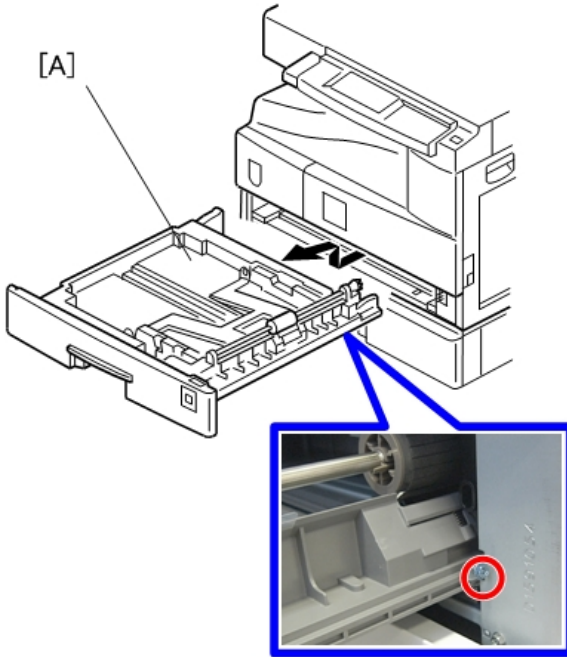

d1585051

2. Rear Cover [A] (⌀ x 9)

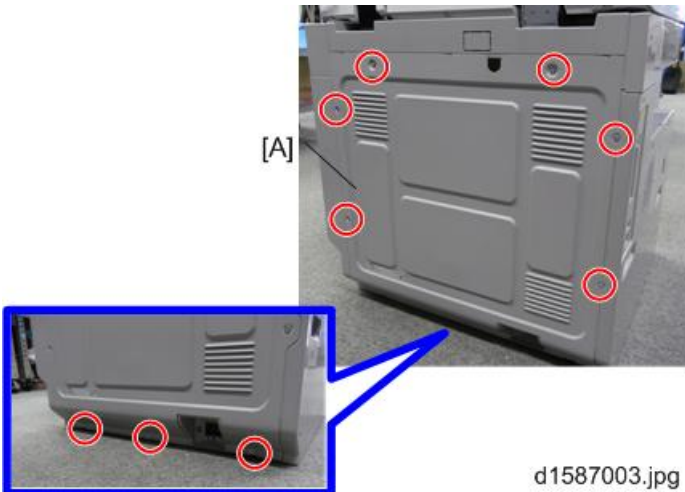

d1587003.jpg

3. Engine Board with the bracket [A] (⚙️ x 5, 🛡️ x all on the board)

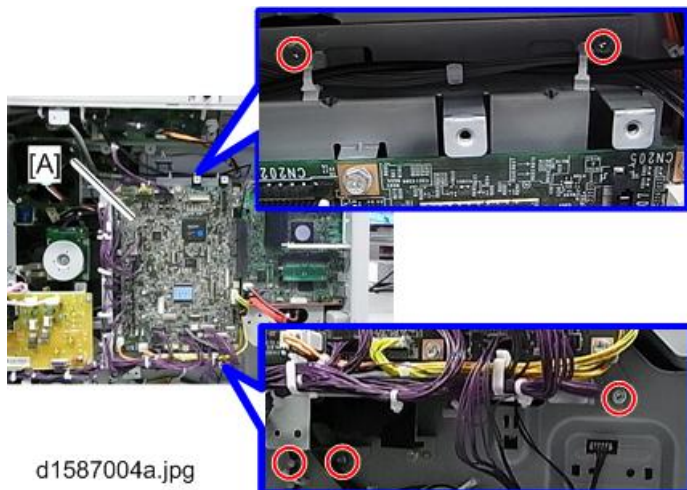

4. Bottom Plate Lift Motor [A] (⚙️ x 3)

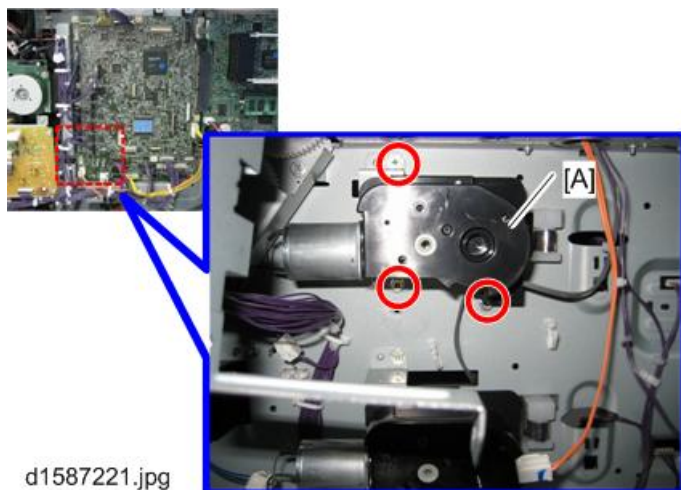

5. Pass the connector [A] through the opening [B] and install the tray heater [C] (⚙️ x 1).

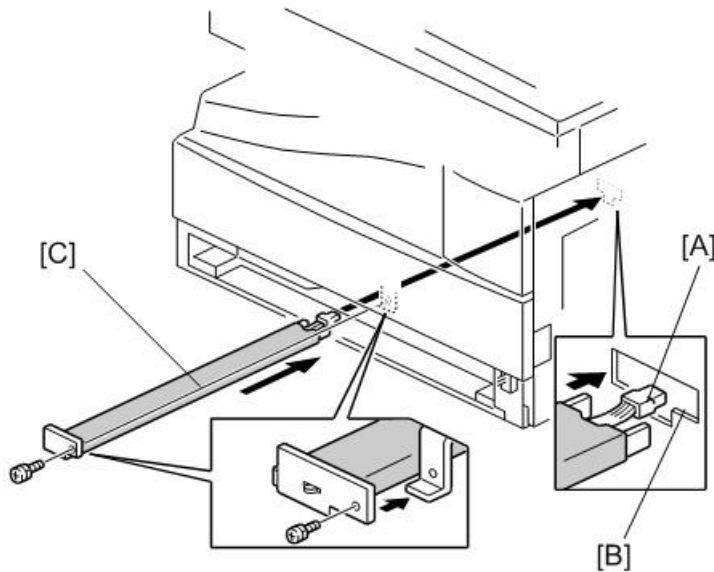

6. Attach the heater harness [A] to the relay connector [B].

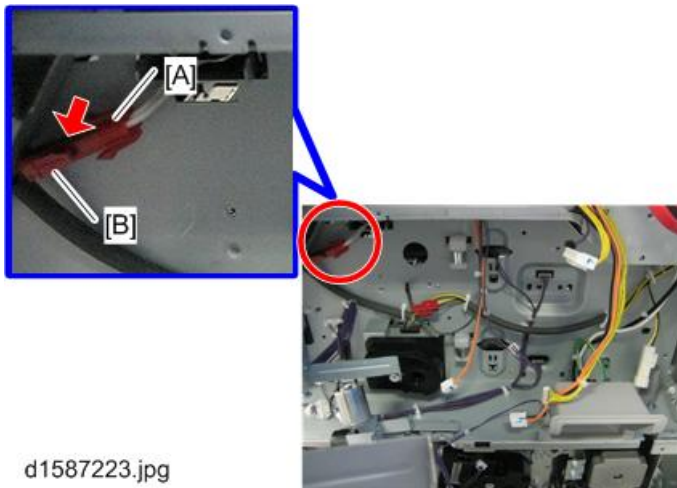

7. Install the harness of the heater and connect it to the PSU. (☛ p.90 "Installing the Harness of the Heater")

Mainframe Lower Tray Heater (Two-tray Model Only)

★ Important

- Unplug the machine power cord before starting the following procedure.

Component Check

Check the quantity and condition of the components against the following list.

No.	Description	Q'ty
1	Heater	1
2	Screw	2
3	Bracket	1

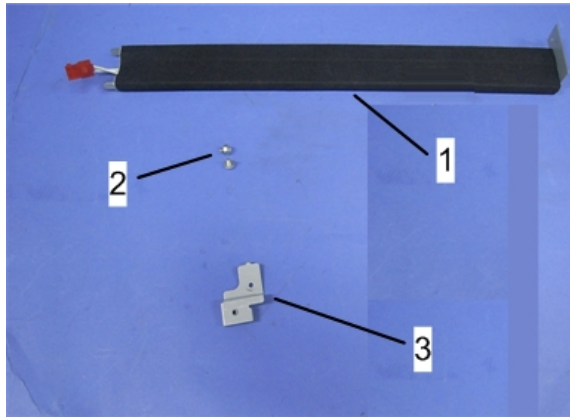

d1582217

Installation Procedure

1. 2nd Tray Cassette [A] (⚙️ x 1)

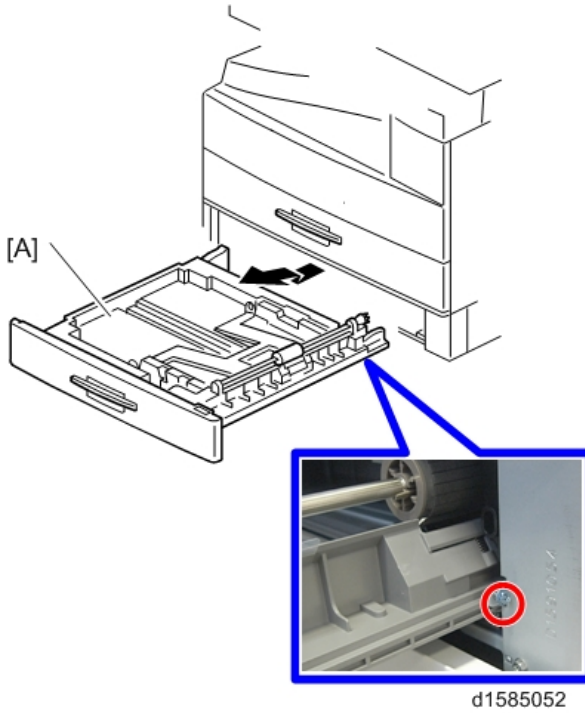

2. Rear Cover [A] (⚙️ x 9)

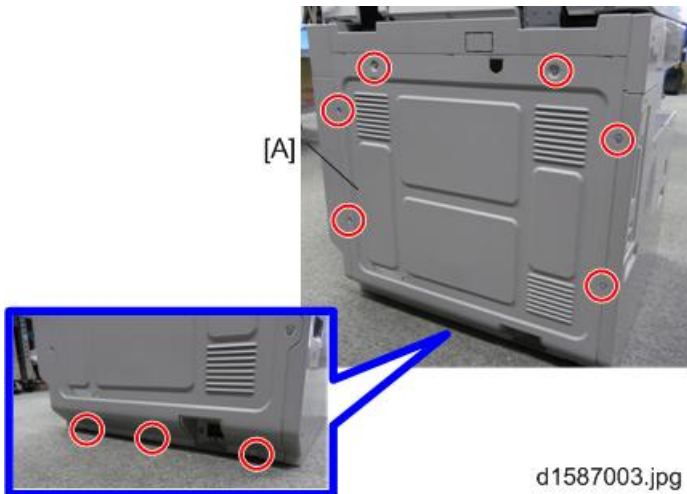

3. Install the bracket [A] (🔩 x 1).

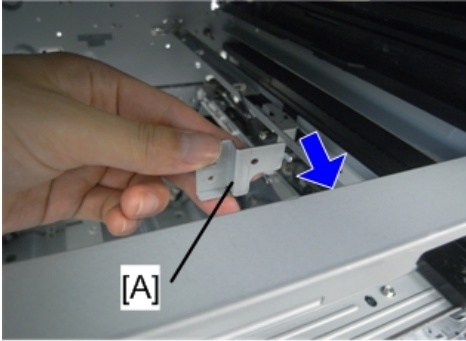

d1582186

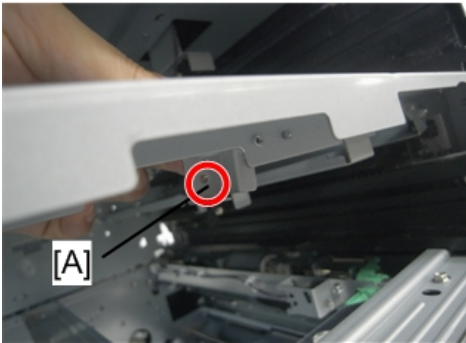

4. Pass the connector [A] through the opening [B] and install the tray heater [C] (🔩 x 1).

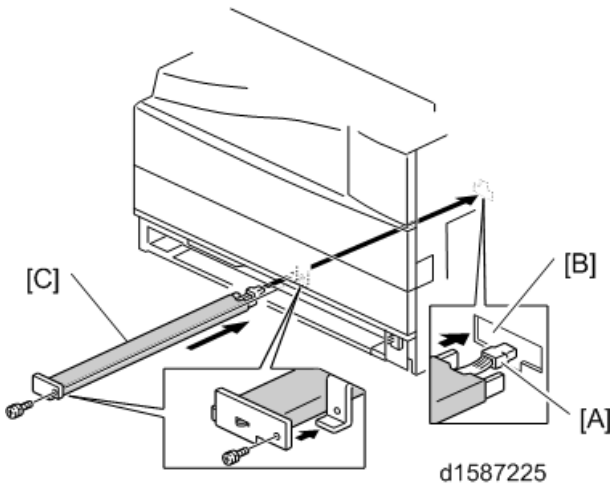

d1587225

5. Join the connectors [A].

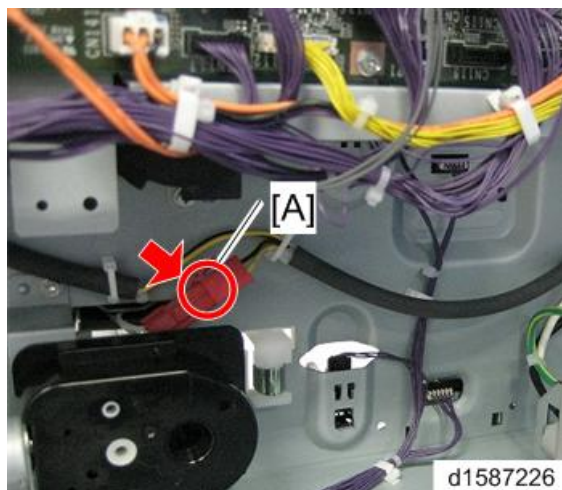

6. Install the harness of the heater and connect it to the PSU. (☞ p.90 "Installing the Harness of the Heater")

Heater for the Optional One-Tray Paper Feed Unit

★ Important

- Unplug the machine power cord before starting the following procedure.

Component Check

Check the quantity and condition of the components against the following list.

No.	Description	Q'ty
1	Heater	1
2	Relay Harness	1
3	Clamp	2
4	Hexagonal-Head Screw	4
5	Round-Head Screw	1
6	Lock Washer Screw	2



Installation Procedure

1. All of the trays in the paper feed unit.
2. Paper Feed Unit Rear cover [A] (4 x 4)

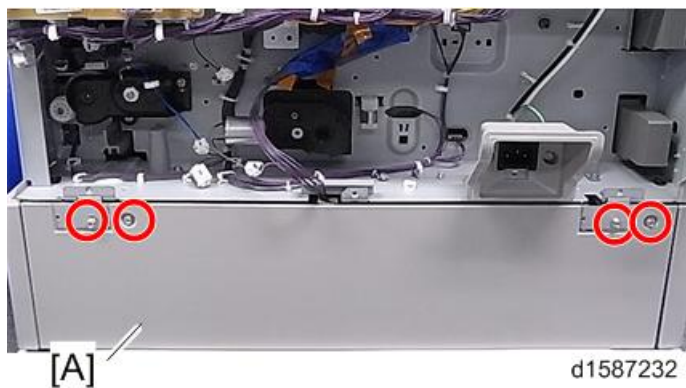

3. Install the clamps [A].

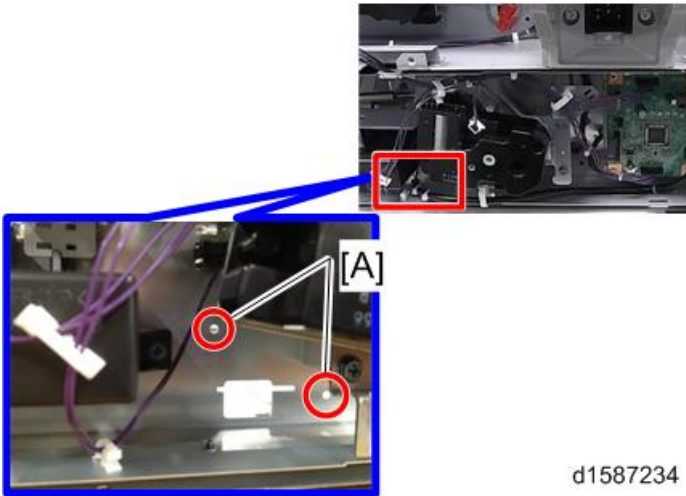

d1587234

4. Pass the connector [A] through the opening [B].

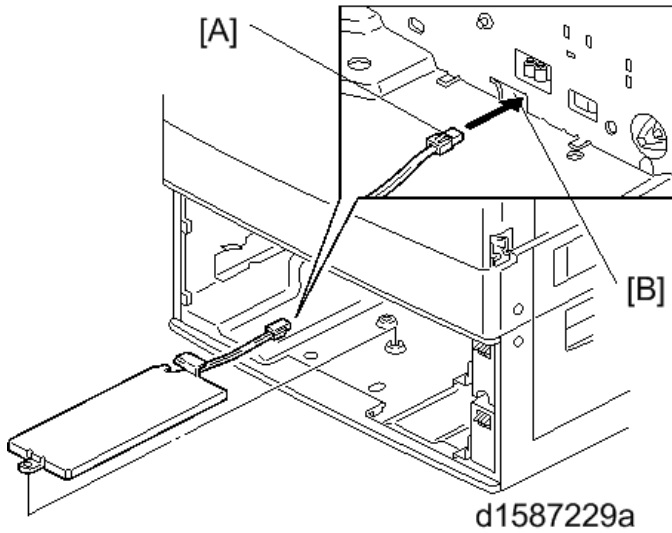

d1587229a

5. Install the tray heater [A] (6 x 5)

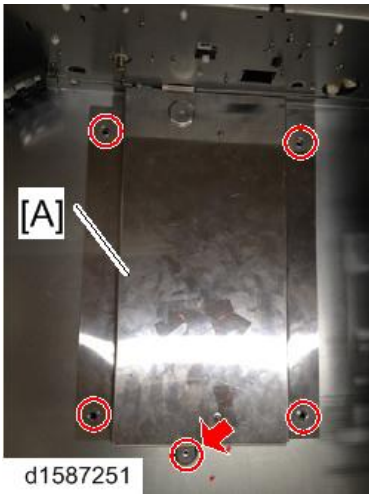

Note

- Two types of accessory screws are used to install the heater. Use the round-head screw to fix the front part that is arrowed. Use the hexagonal-head screws to secure the other parts.

6. Lead the heater connector as shown, and fix it with the clamps [A].

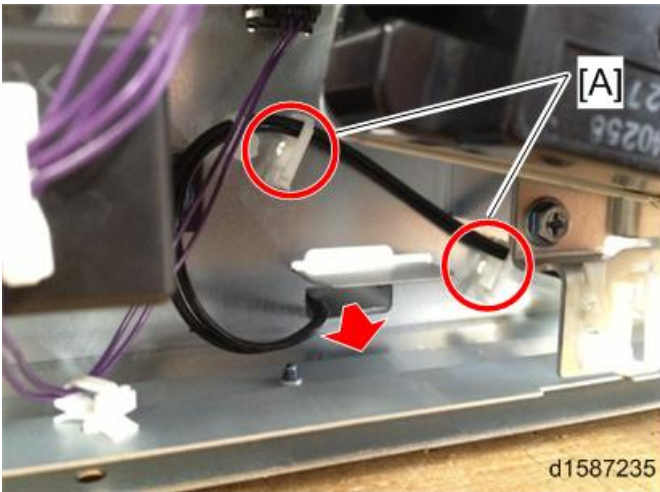

7. Connect the end of the heater harness to the relay harness [A].

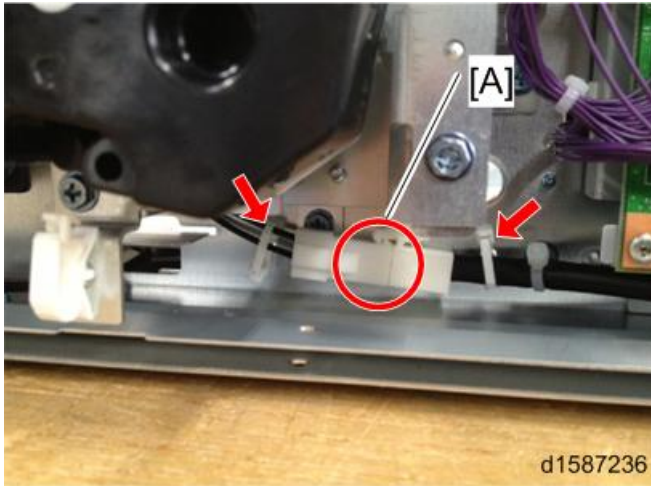

Note

- Be sure to join the connectors between the clamps (arrowed in the picture above).

8. Lead the heater connector and fix it with the clamps [A] as shown.

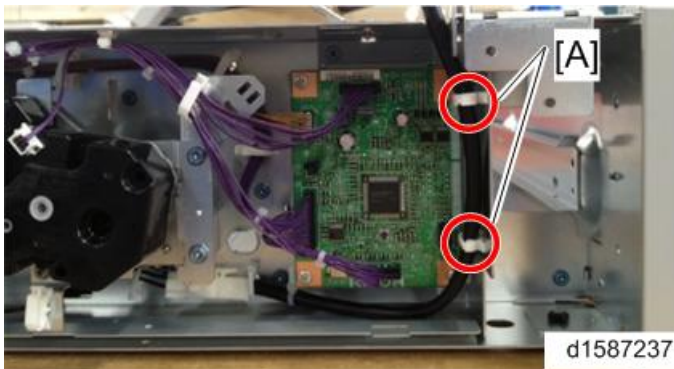

9. Connect the end of the relay harness to the main machine's harness.

10. Replace the screws [A] with screws that have a lock washer.



11. Install the harness of the heater and connect it to the PSU. (☛ p.90 "Installing the Harness of the Heater")

Heater for the Optional Two-Tray Paper Feed Unit

★ Important

- Unplug the machine power cord before starting the following procedure.

Component Check

Check the quantity and condition of the components against the following list.

No.	Description	Q'ty
1	Heater	1
2	Relay Harness	1
3	Hexagonal-Head Screw	4
4	Round-Head Screw	1
5	Lock Washer Screw	2



d1587231

Installation Procedure

1. All of the trays in the paper feed unit.
2. Paper Feed Unit Rear Cover [A] (5 x 5)

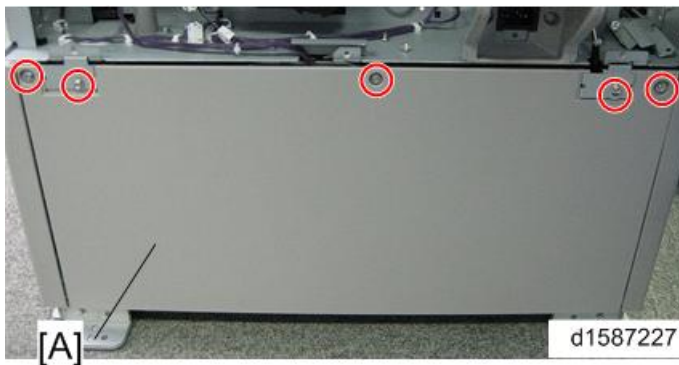

d1587227

3. Pass the connector [A] through the opening [B].

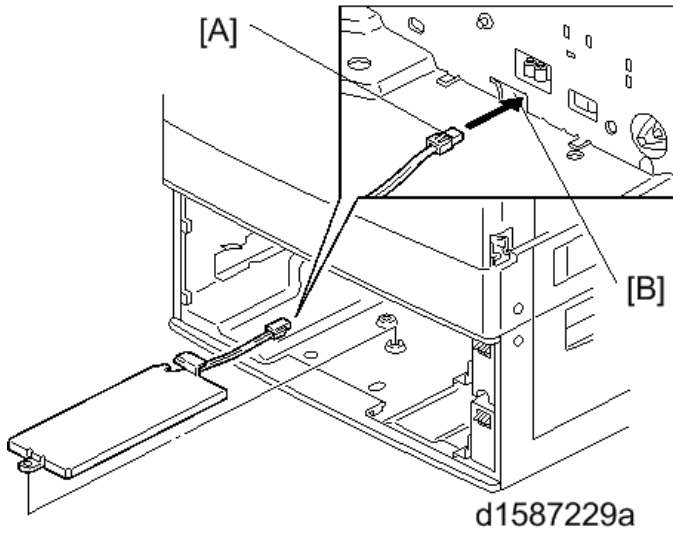

4. Install the tray heater [A] (5 x 5).

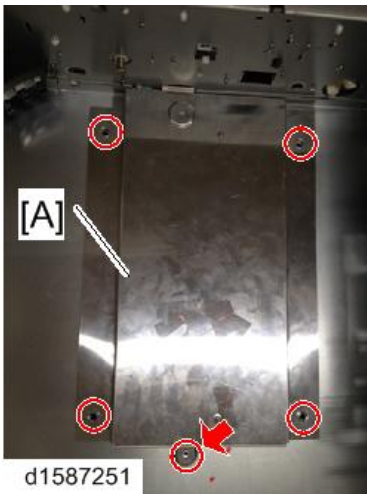

Note

- Two types of accessory screws are used to install the heater. Use the round-head screw to fix the front part that is arrowed. Use the hexagonal-head screws to secure the other parts.

5. Lead the heater harness and fix it with the clamps (circled) as shown.

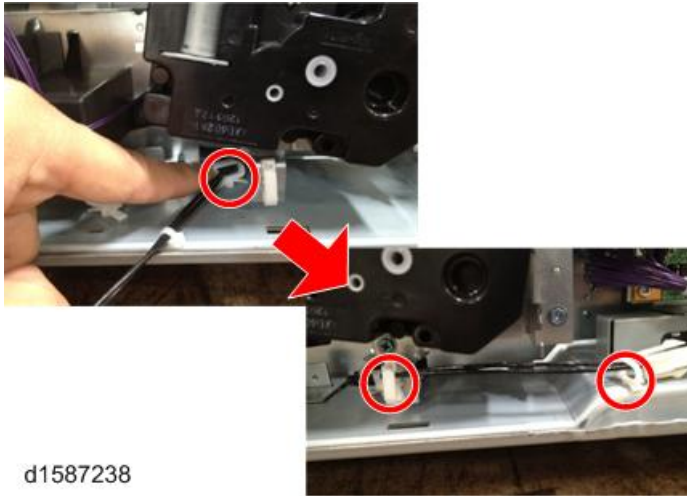

6. Join the harness connector to the relay harness connector.

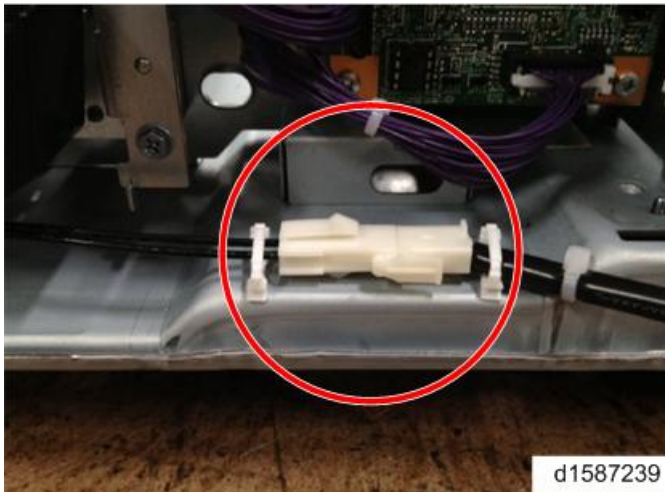

Note

- Be sure to join the connectors between the clamps as shown above.

7. Lead the heater harness and fix it with the clamps [A] as shown.

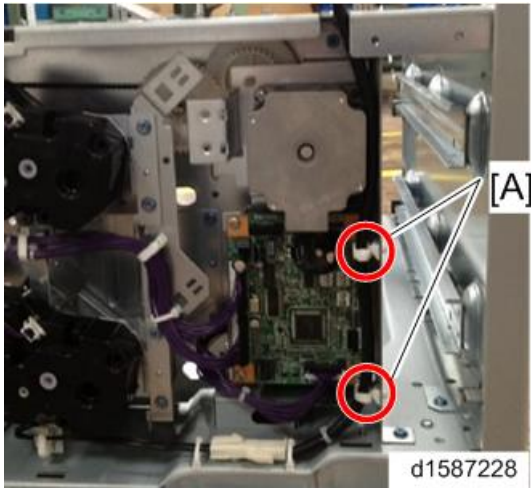

8. Connect the end of the relay harness to the main machine's harness.

9. Replace the screws [A] with screws that have a lock washer.



10. Install the harness of the heater and connect it to the PSU. (☛ p.90 "Installing the Harness of the Heater")

Installing the Harness of the Heater

★ Important

- Unplug the machine power cord before starting the following procedure.

No.	Description	Q'ty
1	Harness for One-Tray Model	1
2	Relay Harness	1
3	Clamp	2
4	Harness for Two-Tray Model	1

2

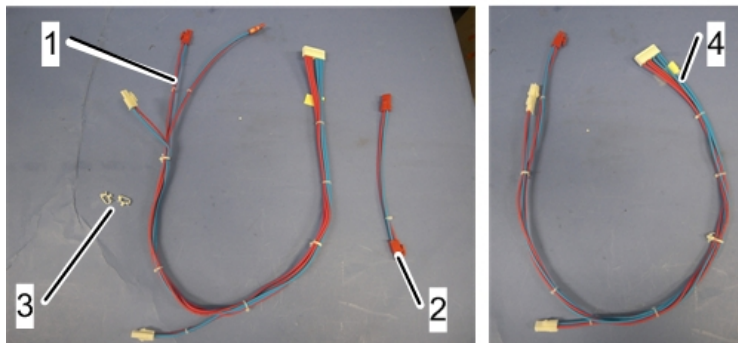

d1582219

1. Connect the harness [A] to the PSU (⏻ x 1, ⏻ x 4).

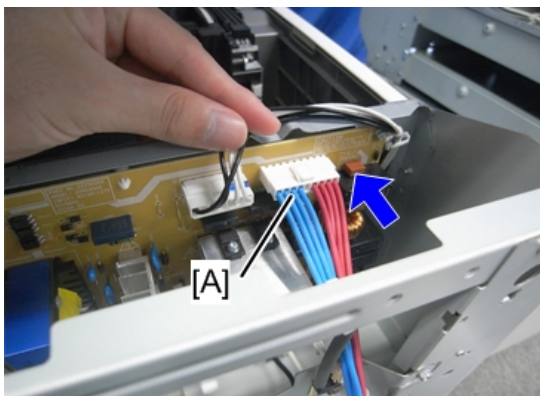

d1582187

2. Connect the connector [A] for the scanner.



d1582188

3. Route the connectors [A] for the standard paper tray and the optional paper feed unit through cut out [B].

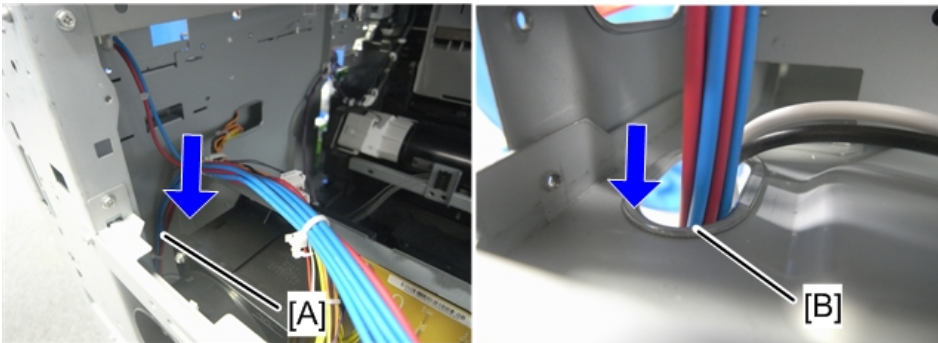

d1582189

4. Connect the relay harness [D] to the connector [A] for the 1st tray cassette.

↓ Note

- The connector [B] is for the 2nd tray cassette, the connector [C] is for the optional paper feed unit.

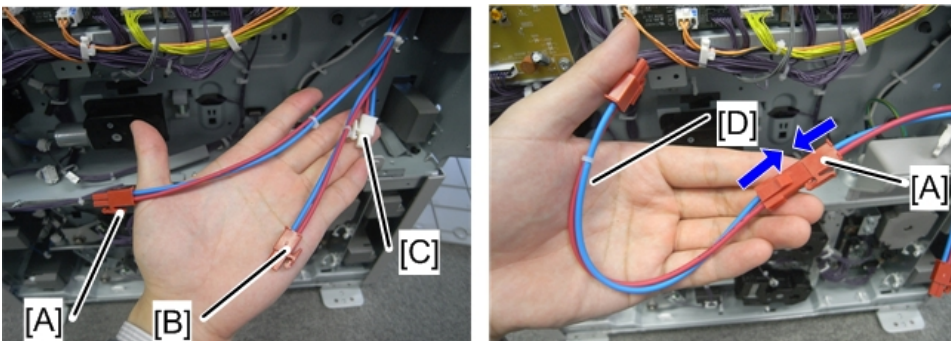

d1582218

5. Clamp the harness [A] with the clamp.

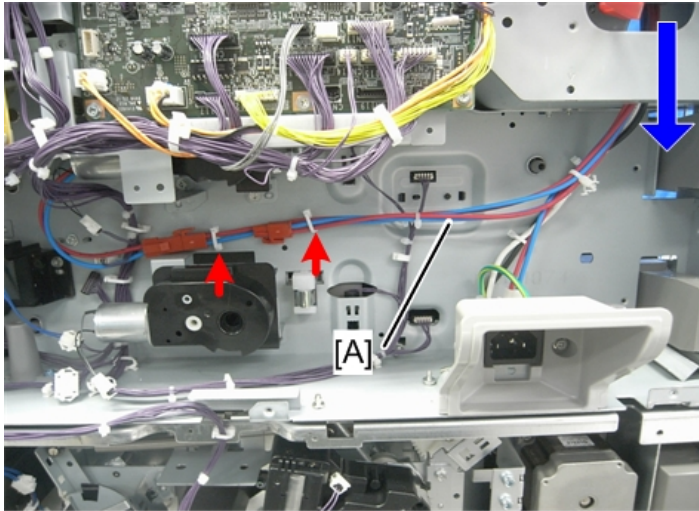

d1582190

6. Reinstall the removed parts.

Counter Interface Unit



Component Check

Check the quantity and condition of the components against the following list.

No.	Description	Q'ty
1	Key Counter Interface Board	1
2	Stud Stay	4
3	Wire Harness (For parallel)	1
4	Wire Harness (For serial)	1

Installation Procedure

CAUTION

- Unplug the machine power cord before starting the following procedure.
1. Rear cover ( p.152)
 2. Right rear cover ( p.160)
 3. Cut off the part [A] of the right rear cover for the device cable.

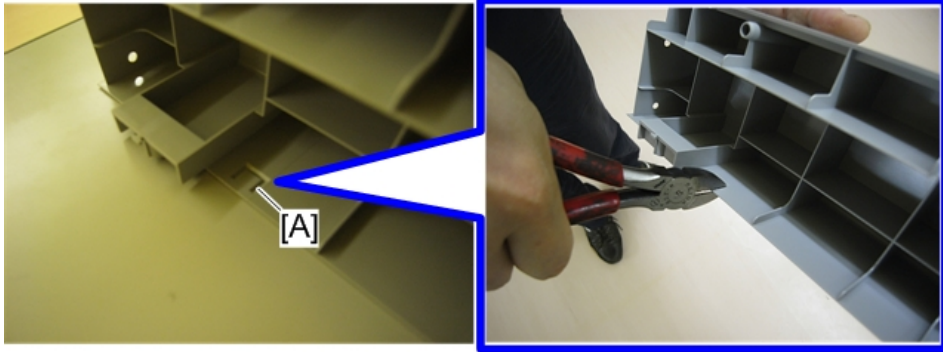

d1582251

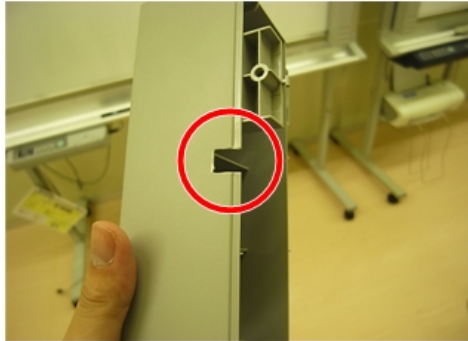

4. Connect the accessory harness to the counter interface board (☐ x 1).

Note

- The parallel harness and the serial harness are included in the component.
- If you use the parallel harness, connect the harness to connector [A] and the device side to [B].
- If you use the serial harness, connect the harness to connector [C] and the device side to [D].

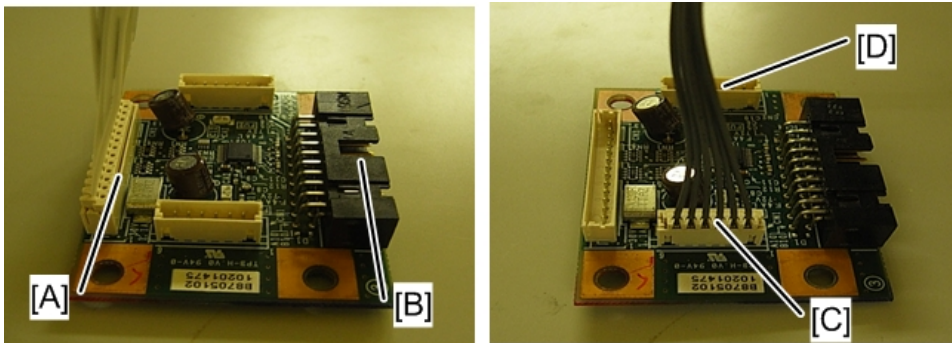

d1582253

5. Attach the plastic holder [B] to the counter interface board [A].

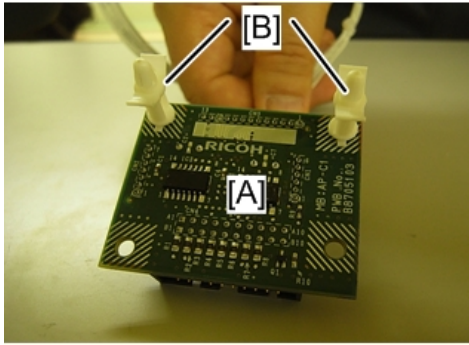

d1582254

6. Install the counter interface board [A] in the right rear cover.

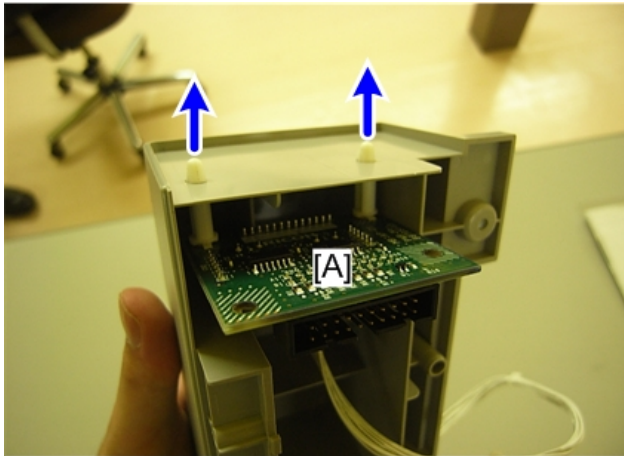

d1582255

7. Install the right rear cover [A] on the main machine. The counter interface board is located as shown below [B].





d1582256

8. Route the harness above the fan and connect the harness to the CTL board.

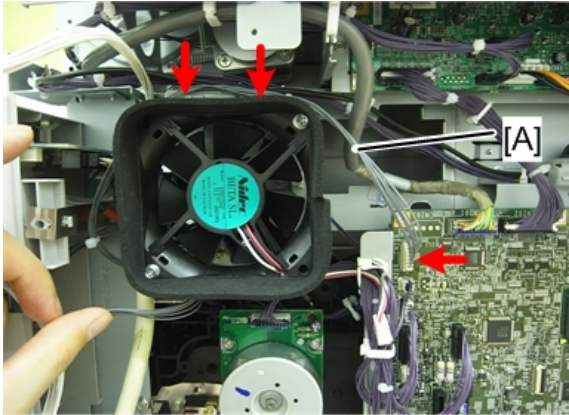
- For the serial harness [A]: ( x2,  (CN206) x1)



d1582257

- For the parallel harness [B]: ( x4,  x1)

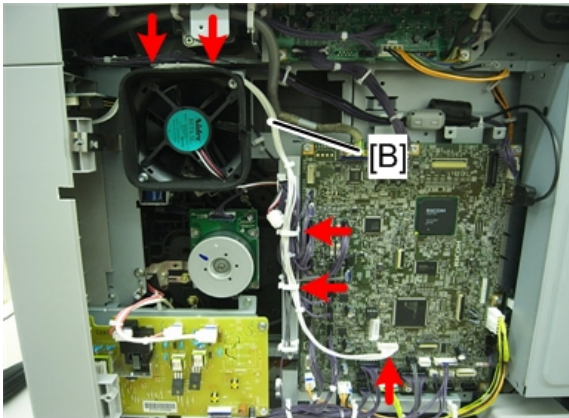

d1582258

9. Connect the device cable [A] ( (CN140) x 1). The picture below shows how to connect the device using the parallel harness.

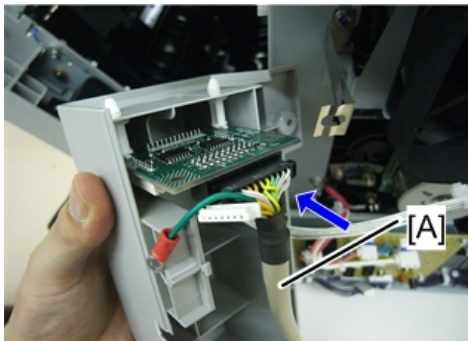

d1582259

10. Route the device cable through the cutout [A].

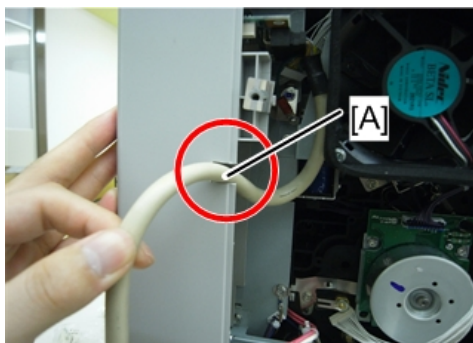

d1582260

11. If there is a ground cable, secure it to the location [A] (⚙ x 1).

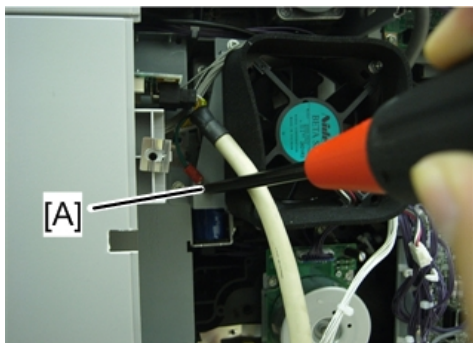

d1582261

12. Reassemble the machine.

GDI Expansion (D160/D161 only)

Component Check

No.	Description	Q'ty
1	GDI CTL with NIC	1
2	Installation Procedure (-27 only)	1
3	Decal: China RoHS: 10 Circle (-28 only)	1
4	Decal: China RoHS: Date (-28 only)	1

2

Installing the Expansion Component

⚠ CAUTION

- Unplug the machine power cord before starting the following procedure.

1. Rear cover [A] (🔧 x 9)

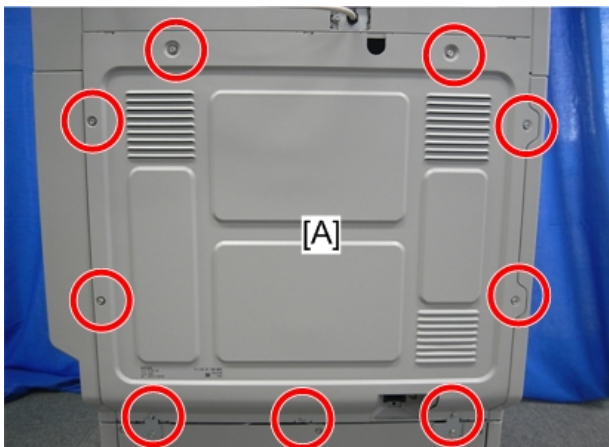

d1582005

2. Interface cover [A] (⚙️ x 1)

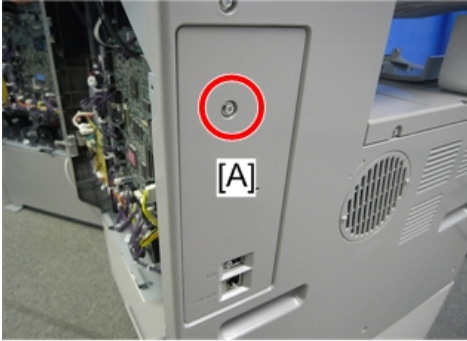

d1582013

3. Slide the BICU [A] (⚙️ x 5)

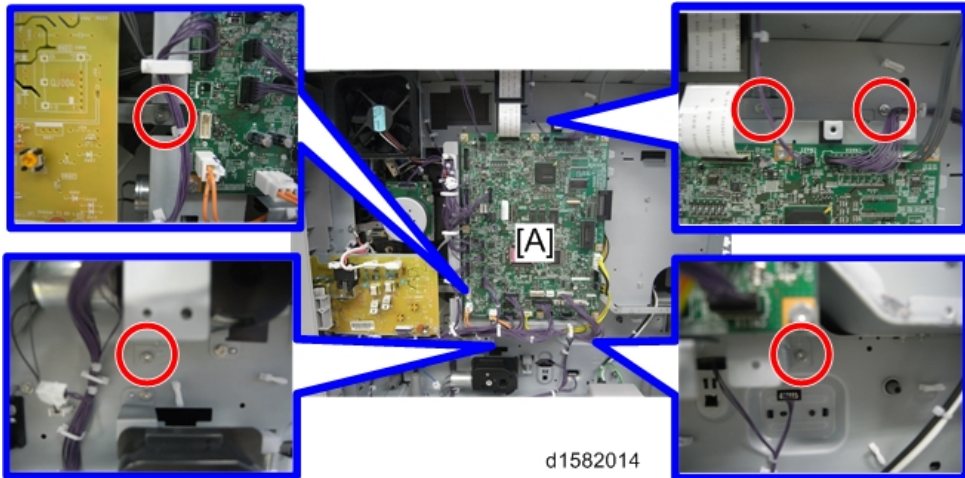

d1582014

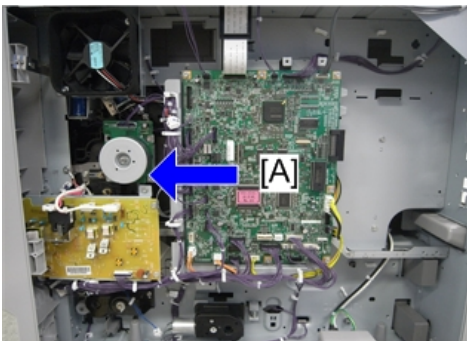

d1582015

4. Install the GDI Expansion [A] (⚙️ x 5).

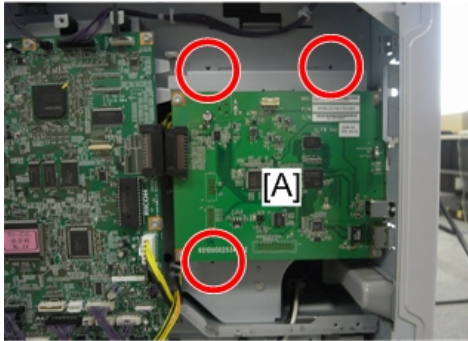

d1582016

↓ **Note**

- Make sure that the GDI Expansion is connected securely. If not, SC672 occurs.

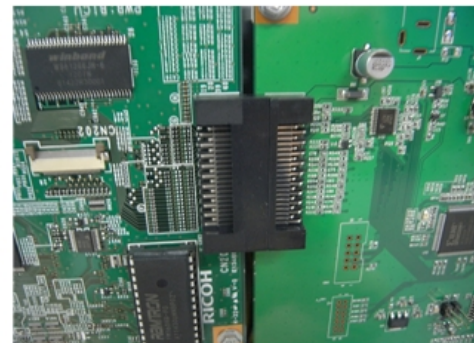
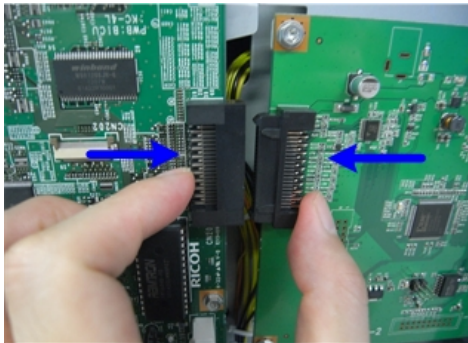

d1582017

5. Reinstall the BICU (⚙️ x 5).

6. Reinstall the interface cover (⚙️ x 1).

7. Reinstall the rear cover (⚙️ x 9).

Hard Disk Drive Option (D158/D159 only)

Component Check

2

No.	Description	Q'ty
1	HDD Unit	1
2	Connecting rubber	4
3	Tapping screw	4
4	Harness 1	1
5	Harness 2	1
-	EMC traceability sheet	1
-	D-BOX key Decal	1
-	RoHS Decal (China only)	1
-	RoHS Date Decal (China only)	1



d1582004

Installation Procedure

★ Important

- Unplug the machine power cord before starting the following procedure.

1. Rear cover [A] (🔧 x 9)

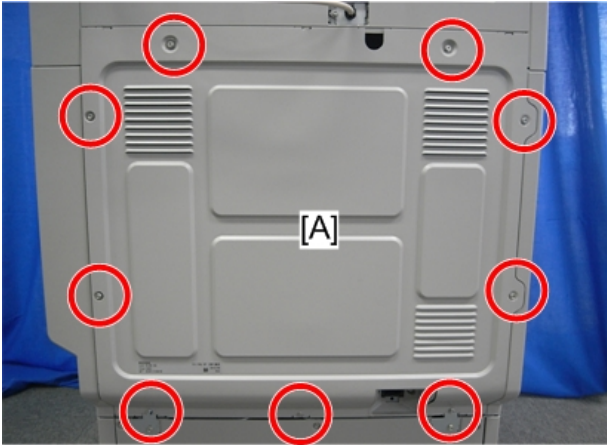

d1582005

2. Separate the BICU [A] from the CTL Board [B] (🔧 x 5, 📏 x 2).

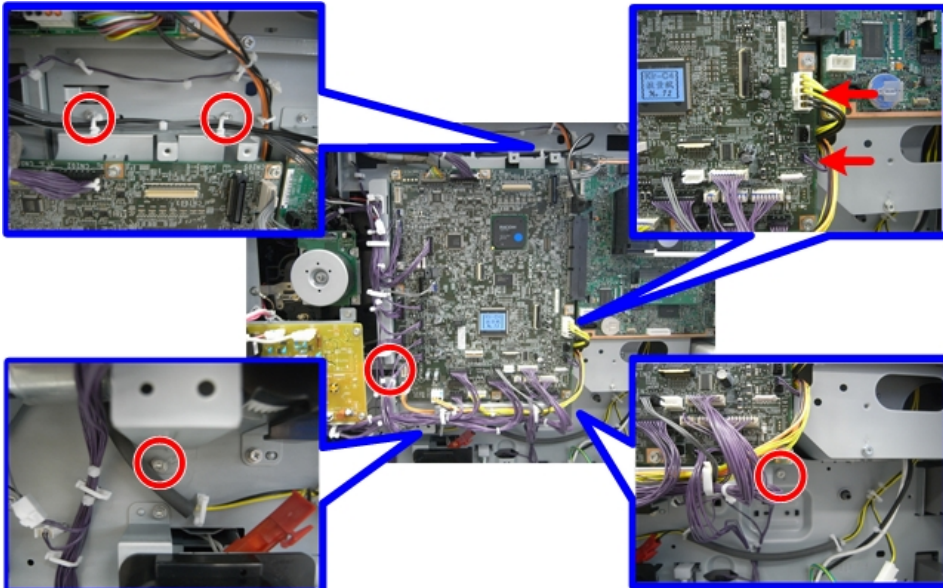

d1582006

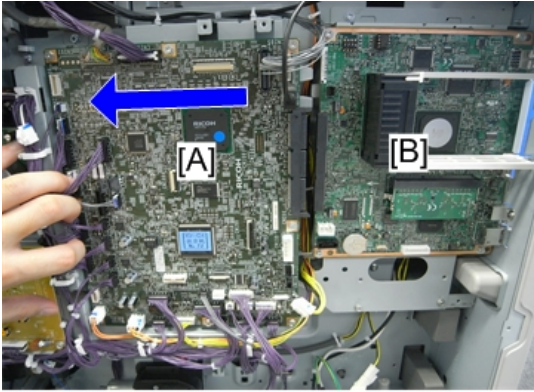

d1582007

3. Nine screws (⌀ x 9)



d1582008

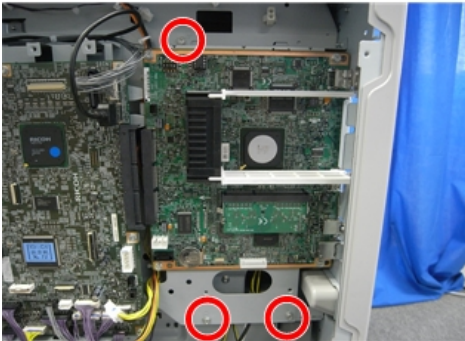

4. Slide the CTL board [A] to the left and pull down as shown below.

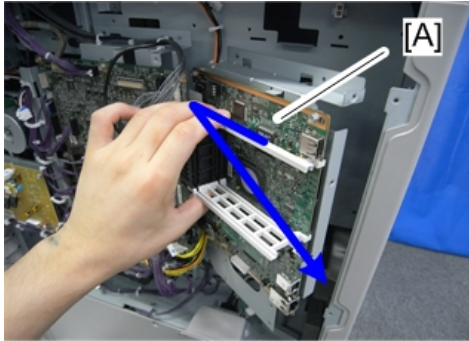

d1582009

5. Install the connecting rubber [A] on the CTL board bracket.

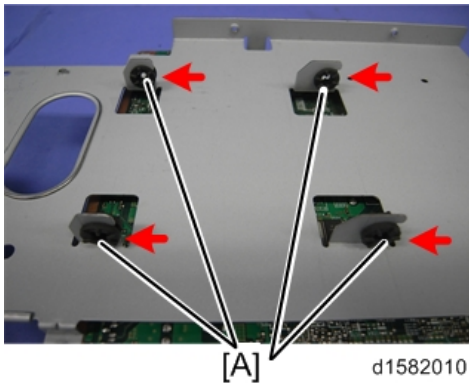

d1582010

6. Install the HDD unit [A] (⚙️ x 4).

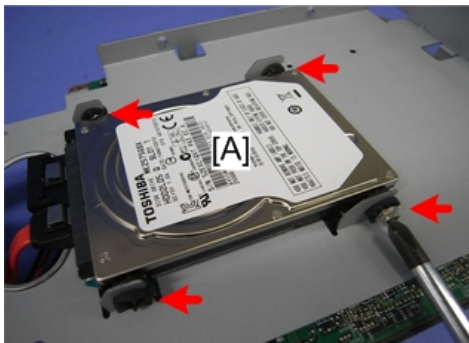

d1582011

7. Connect the two harnesses to the HDD unit (🔌 x 2).



d1582012

8. Reinstall the CTL board unit in the machine.
9. When you turn the main power switch on after installing the hard disk, initialization of the disk starts automatically.
10. Once a completion message appears, turn the power off.

Note

- When installing the BICU, or CTL board, make the connection [A] securely. If not, an SC occurs.

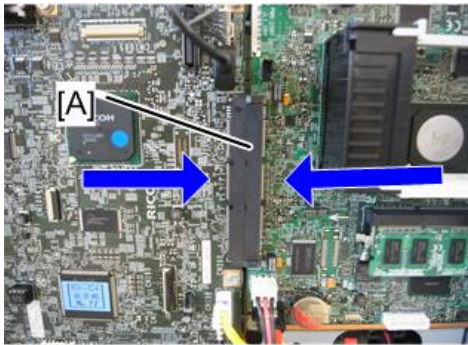

d1583007

Data Overwrite Security

Do the following procedure if a customer wants to use this function.

1. Do SP5-878-1 (Option Setup - Data Overwrite Security) and touch [EXECUTE].
2. Go out of the SP mode, turn off the operation switch, then turn off the main power switch.
3. Turn the machine power on.
4. Press [User Tools] and select System Setting > Administrator Tools > Auto Erase Memory Setting > On
5. Exit from User Tools mode.

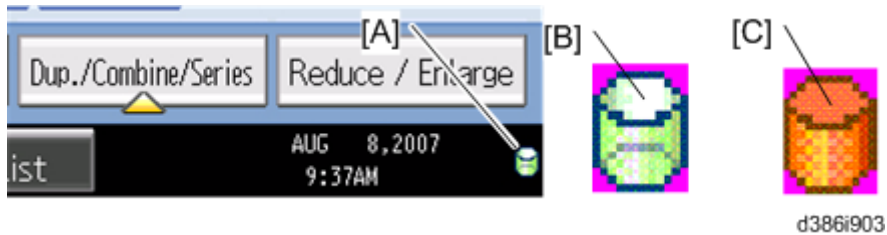

6. Check the display and make sure that the overwrite erase icon [A] is displayed.
7. Make a Sample Copy.
8. Check the overwrite erase icon.
 - The icon [B] changes to [C] when job data is stored in the hard disk.
 - The icon goes back to its usual shape [B] after this function has completed a data overwrite operation to the hard disk.
9. Do SP5990-005 (SP print mode - Diagnostic Report).
10. Look at the report:
 - Under "[ROM No./Firmware Version]" check the number and version number listed for "HDD Format Option".
 - Under "[Loading Program]" check the option number and version number listed for "GW_zoffy".
 - These two version numbers should be identical.
11. Exit SP mode.

HDD Encryption

Do the following procedure if a customer wants to use this function.

1. Do SP5-878-2 (Option Setup - Encryption Option) and touch [EXECUTE]
2. Go out of the SP mode, turn off the operation switch, then turn off the main power switch.
3. Turn the machine power on.
4. Push [User Tools] and select System Setting > Administrator Tools > Machine Data Encryption Setting.

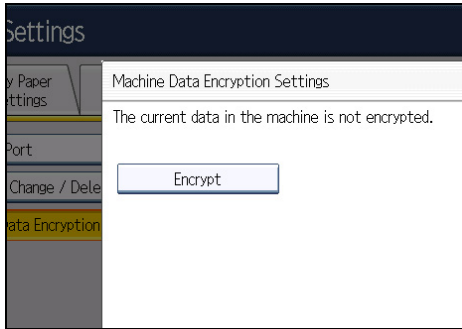

5. Press [Encrypt].

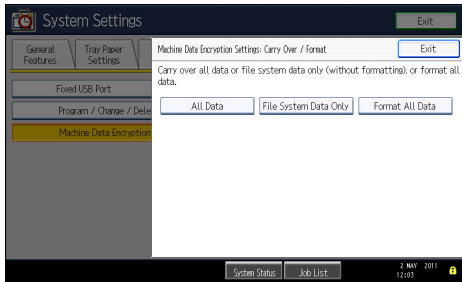

6. Select the data to be carried over to the hard disk and not to be reset

To carry all of the data over to the hard disk, select [All data]. To carry over only the machine setting data, select [File System Data Only]. To reset all of the data, select [Format All Data].

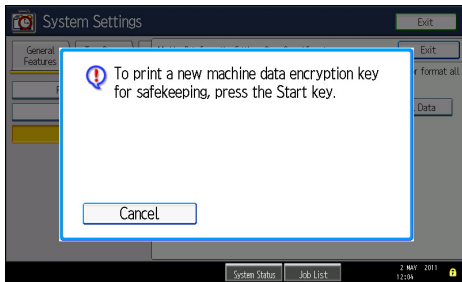

7. Press the [Start] Key.

The encryption key for backup data is printed.

Controller Options

Overview

★ Important

- Always touch a grounded surface to discharge static electricity from your hands before you handle SD cards, printed circuit boards, or memory boards.

This machine has I/F card slots for optional I/F connections and SD card slots applications.

After you install an option, check that the machine can recognize it (☞ p.146 "Check All Connections").

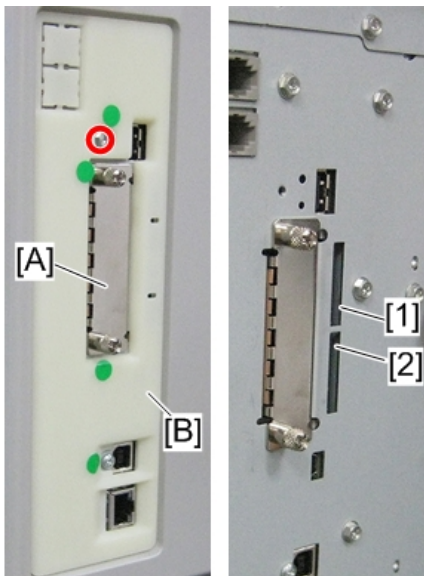

d1585001

Remove the card slot cover [B] to use the SD card slots (☞ x 1).

I/F Card Slot

- Slot [A] is used for one of the optional I/F connections (only one can be installed): IEEE1284, or IEEE802.11a/b/g (Wireless LAN).

SD Card Slots

- Slot 1 (upper) [1] is used for optional applications (e.g.: Netware, Postscript3, Browser Unit, Fax Connection Unit, etc).

- Slot 2 (lower) [2] is used for installing applications, or for service only (for example, updating the firmware).

SD Card Appli Move

2

Overview

The service program "SD Card Appli Move" (SP5-873) lets you move application programs from one SD card to another SD card.

If more than one application is required, the applications must be moved to one SD card with SP5-873-001 (Security Application, PictBridge, etc.).

Be very careful when you do the SD Card Appli Move procedure:

- The data necessary for authentication is transferred with the application program from an SD card to another SD card. Authentication fails if you try to use the SD card after you move the application program from one card to another card.
- Do not use the SD card if it has been used before for other purposes. Normal operation is not guaranteed when such an SD card is used.
- Keep the SD card in the place after you copy the application program from one card to another card. This is done for the following reasons:
 - The SD card can be the only proof that the user is licensed to use the application program.
 - You may need to check the SD card and its data to solve a problem in the future.

Move Exec

The menu "Move Exec" (SP5-873-001) lets you move application programs from the original SD card to another SD card.

★ Important

- **Do not turn ON the write protect switch of the system SD card or application SD card on the machine. If the write protect switch is ON, a download error (e.g. Error Code 44) occurs during a firmware upgrade or application merge.**
1. Turn the main switch off.
 2. Make sure that a target SD card is in SD Card Slot 1 (upper). The application program is moved to this SD card.
 3. Insert the source SD card with the application program in SD Card Slot 2 (lower). The application program is copied from this source SD card.
 4. Turn the main switch on.
 5. Start the SP mode.

6. Select SP5-873-001 "Move Exec".
7. Follow the messages shown on the operation panel.
8. Turn the main switch off.
9. Remove the source SD card from SD Card Slot 2 (lower).
10. Turn the main switch on.
11. Check that the application programs run normally.

Undo Exec

"Undo Exec" (SP5-873-002) lets you move back application programs from an SD card in SD Card Slot 1 (upper) to the original SD card in SD Card Slot 2 (lower). You can use this program when, for example, you have mistakenly copied some programs by using Move Exec (SP5-873-001).

★ Important

- **Do not turn ON the write protect switch of the system SD card or application SD card on the machine. If the write protect switch is ON, a download error (e.g. Error Code 44) occurs during a firmware upgrade or application merge.**
1. Turn the main switch off.
 2. Insert the original SD card in SD Card Slot 2 (lower). The application program is copied back into this card.
 3. Insert the SD card with the application program in SD Card Slot 1 (upper). The application program is copied back from this SD card.
 4. Turn the main switch on.
 5. Start the SP mode.
 6. Select SP5-873-002 "Undo Exec."
 7. Follow the messages shown on the operation panel.
 8. Turn the main switch off.
 9. Remove the SD card from SD Card Slot 2 (lower).
 10. Turn the main switch on.
 11. Check that the application programs run normally.
 12. Make sure that the machine can recognize the option (☛ p.146 "Check All Connections").

VM Card (D158/D159)

Installation Procedure

CAUTION

- Unplug the main machine power cord before you do the following procedure.

1. Remove the card slot cover [A] (⚙ x 1).
2. Insert the SD card into slot 2 [B].

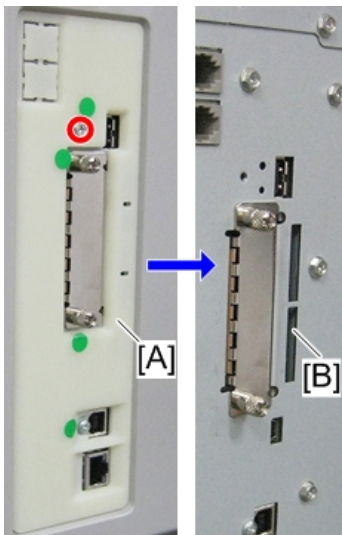

d1585004

3. Reattach the card slot cover.
4. Turn the main switch on.
5. On the operation panel, remove the bottom blank keytop and replace it with the keytop provided.
6. Attach the decal to the machine.

Firmware Update Procedure

Application halt

1. Press the "User Tools/Counter" key, then touch "Extended Feature Settings" twice on the LCD. If required, log in as a machine administrator.
2. Press "Administrator Tools", then press "Heap/Stack Size Settings". Take note of the heap size and stack size. (After updating, the heap and stack size settings are cleared.)
3. Press "Startup", then stop all applications.

★ Important

- The following problems can occur if the VM firmware is updated without the application halt. The VM firmware update fails.
 - All settings for the application are cleared.
4. Turn the main switch off, then remove the card slot cover.
 5. Remove the VM SD card from the SD card slot.

Updating the VM SD card

1. Insert the SD card into the SD card writer that is connected to a PC.
2. Make sure which drive is assigned for the SD card.
3. Decompress the downloaded update file, then there are two files (one file has an ".exe" file extension and the other has a ".bat" file extension).
4. Double click the ".bat" file, then the command prompt screen appears.
5. The first command line is shown as
"Please input drive letter of SD card [a - x]:"
Then enter the SD card drive name, and press the "Enter" key.
6. "Press any key to continue..." appears, then press the "Enter" key again. The update to the SD card starts.
7. "Press any key to continue..." appears again, then press "Enter" key. The command prompt screen disappears automatically if the update is successful.
8. Remove the SD card from the SD card writer after the access lamp going off on the SD card writer.
9. Insert the SD card in the SD card slot 2 of the machine and turn the main switch on.

Starting the application

1. Press the "User Tools/Counter" key, then touch "Extended Feature Settings" twice on the LCD. If required, log in as a machine administrator.
2. Press "Startup Setting", then change the status to "Starting up" for each application.
3. Press "Exit".
4. Press "Administrator Tools", then press "Heap/Stack Size Settings". Program the heap size and stack size as the settings as before.
5. Turn the main switch off and on.
6. Enter the "Extended Feature Settings" menu again, and check the version of the VM card firmware on the "Extended Feature Info" screen.

↓ Note

- The version of the VM card firmware is also shown on the Self Diagnostic Report (a part of the SMC report). But the version on the Self Diagnostic Report is not changed after updating.

Copy Data Security Unit (D158/D159)

Component Check

No.	Description	Q'ty	For this model
1	Bracket 1	1	Yes
2	Screws: M3 x 4	2	Yes
3	Screws: M3 x 6	4	Yes
4	ICIB-3	1	Yes

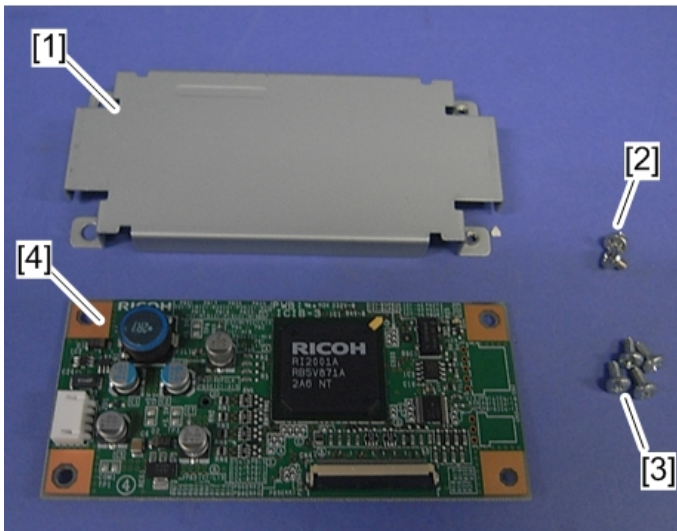

d1585017

Installation Procedure

⚠ CAUTION

- Unplug the main machine power cord before you do the following procedure.

1. Rear cover (🔧 p.152)
2. Attach bracket [A] to the ICIB-3 [B] (🔩 x 2).



d129i303

3. Align the dent [B] with the connector [C] and connect the ICIB-3 with bracket 1 [A] on the BICU (x 2).

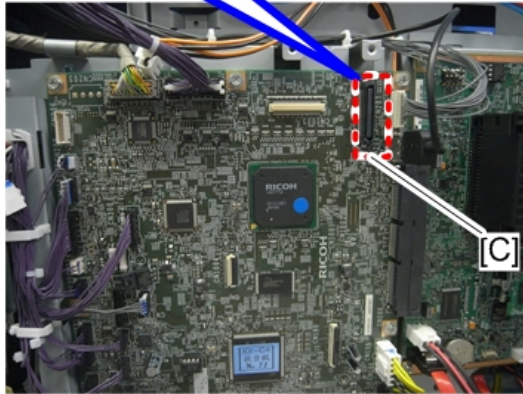
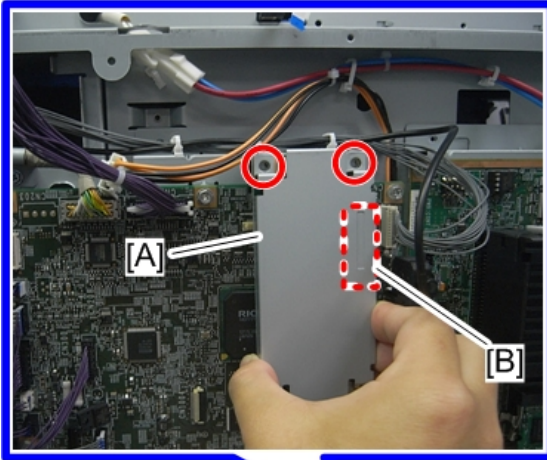

d1585026

4. Plug in, and turn the main switch on. The LED as shown below is blinking when the copy data security unit is correctly installed.



d1585027

5. Reassemble the machine.

User Tool Setting

1. Plug in, and turn the main switch on.
2. Go into the User Tools mode, and select System Settings > Administrator Tools > Detect Data Security for Copying > "On".
3. Exit the User Tools.
4. Check the operation.

Note

- The machine will issue an SC165 error if the machine is powered on with the ICIB-1 removed and the "Detect Data Security for Copying" feature is set to "ON".
- When you remove this option from the machine, first set the setting to "OFF" with the user tool before removing this board. If you forget to do this, "Detect Data Security for Copying" feature cannot appear in the user tool settings. And then SC165 will appear every time the machine is switched on, and the machine cannot be used.

2

File Format Converter (D158/D159)

Installation Procedure

CAUTION

- Unplug the main machine power cord before you do the following procedure.
1. Remove the card slot cover [A] (1 x 1).
 2. Install the file format converter [B] into the board slot and then fasten it with screws.

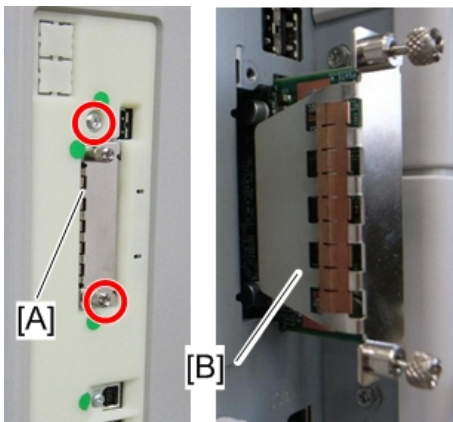

d1585005

3. Plug in, and turn the main switch on.
4. Check or set the following SP codes with the values shown below.

SP No.	Title	Setting
SP5-836-001	Capture Function (0:Off 1:On)	"1"
SP5-836-002	Panel Setting	"0"

5. Check the operation.
6. Make sure that the machine can recognize the option (☛ p.146 "Check All Connections").

Browser Unit (D158/D159)

Installation Procedure

This option requires a HDD unit.

1. Turn the main switch ON.
2. Push the [User Tools/Counter] key.
3. On the touch panel, press "System Settings".
4. Make sure that the "Increase Scanner Memory by Disabling Browser" setting in the General Features tab is OFF.
5. Turn the main switch OFF.
6. Remove the card slot cover [A] for SD cards (☛ x 1).
7. Insert the Browser Option SD card in SD slot 2 [B].

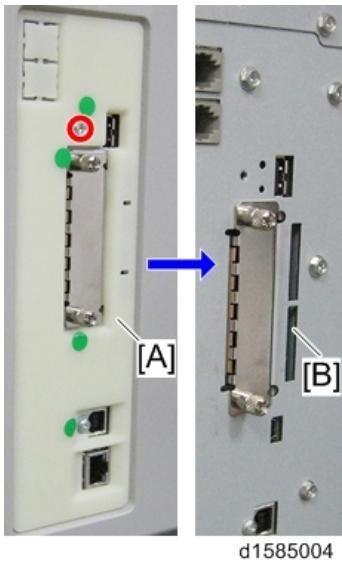

8. Turn the main switch on.

9. Push the [User Tools/Counter] key.
10. Touch "Extended Feature Settings" twice on the LCD.

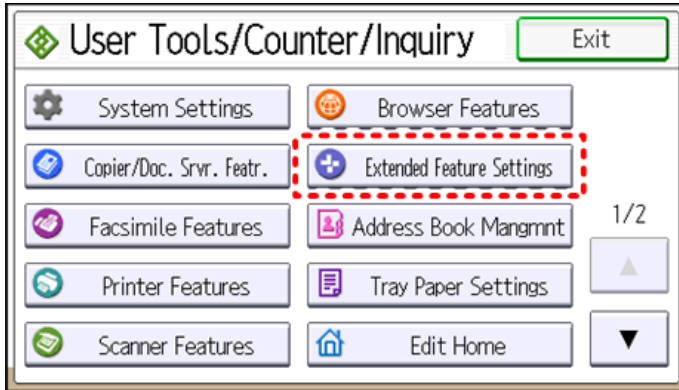

w_d1585058

11. Make sure that "Extended JS" application was automatically installed in the Startup Settings tab.
12. Turn the main switch OFF/ON.
13. Push the [User Tools/Counter] key.
14. Touch "Edit Home".

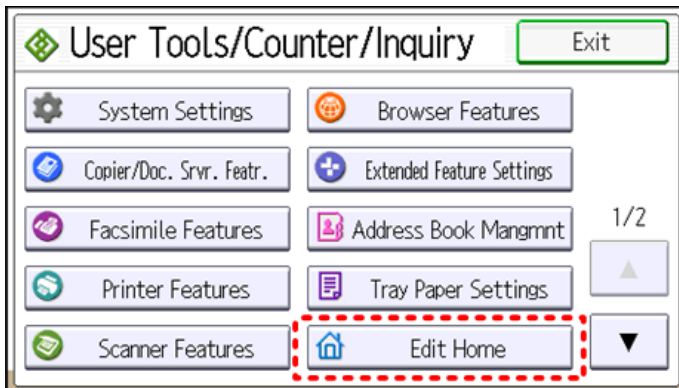

w_d1585006

15. Touch "Add Icon".

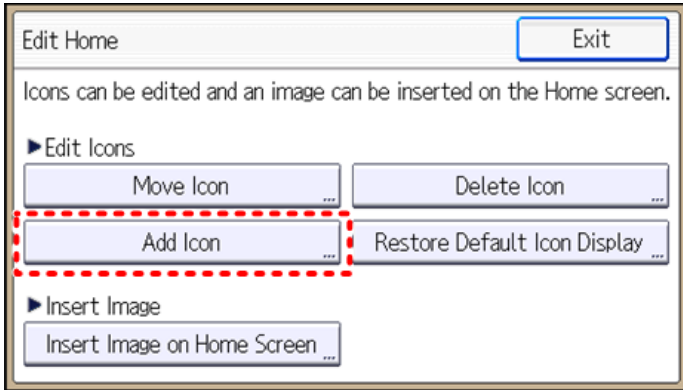

w_d1585007

16. Touch "Select Icon to Add".

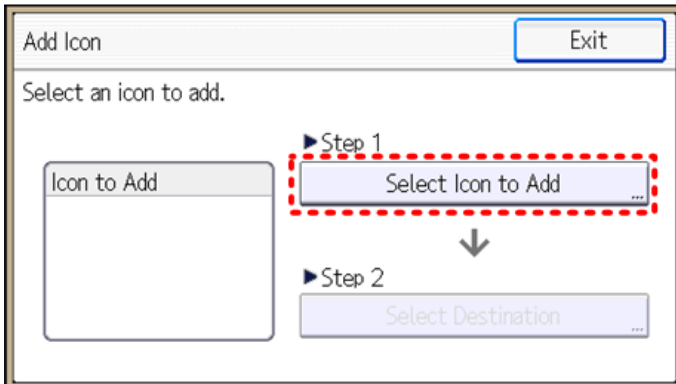

w_d1585008

17. Touch "Application".

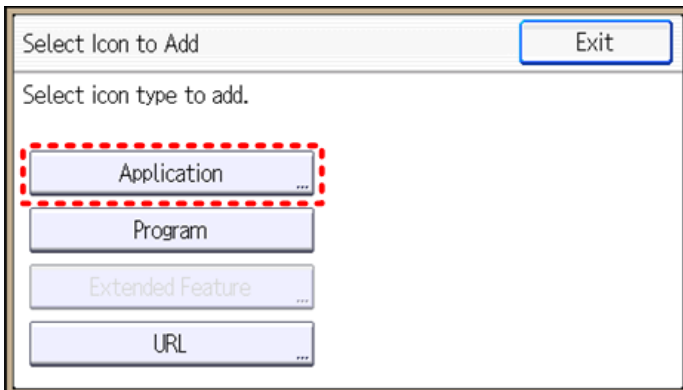

w_d1585009

18. Touch "Browser"

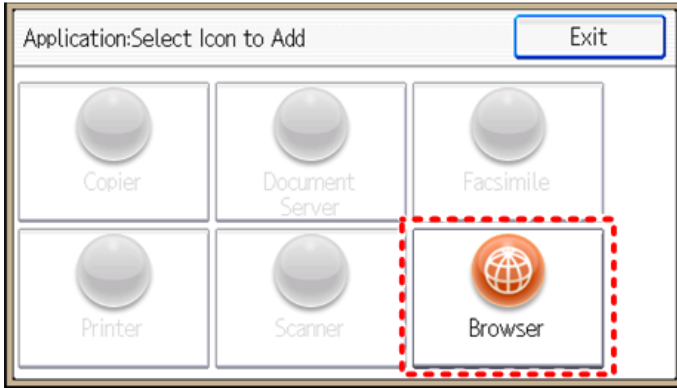

w_d1585010

19. Touch "Select Destination".

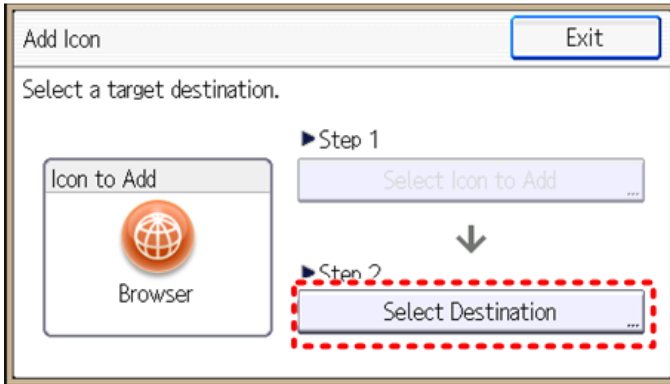

w_d1585011

20. Touch a "Blank" to set a location for the browser icon.

21. Touch "Exit" to end the fax browser icon addition.

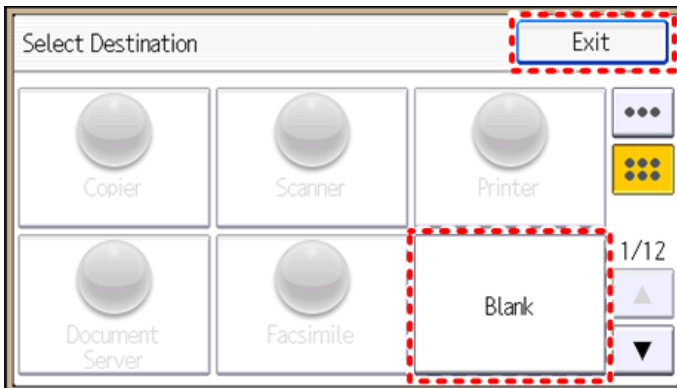

w_d1585012

Ricoh JavaScript

Do the following steps if the customer is using the Ricoh JavaScript connected to a Web application developed by Operius/RiDP.

1. Turn the main switch ON.
2. Push the [User Tools/Counter] key.
3. Touch "Browser Features".

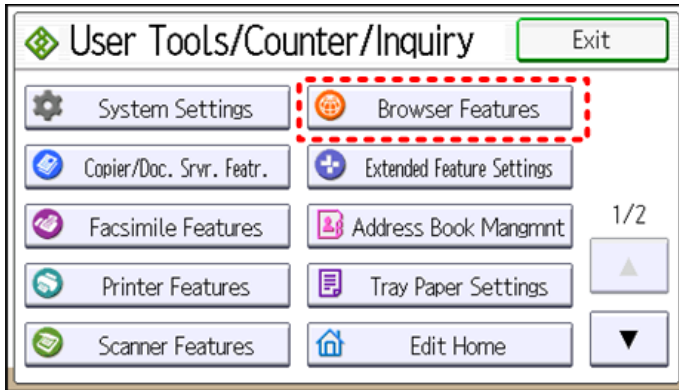

w_d1585059

4. Touch "Java Script".
5. Change the Extended JavaScript setting to "Activate".

EXJS Firmware Update

↓ Note

- The Browser Unit consists of the Browser firmware and EXJS firmware. The EXJS firmware is equivalent to the existing browser firmware. Therefore, it is possible to update the EXJS firmware using the same procedure as that of SDK application firmware.

-Preparation-

1. Extract the exe file (XXXX. exe), after which the following two files are generated: XXXX_machine.exe/ XXXX_stock.exe.

↓ Note

- Note: The file (XXXX_machine) is for updating the EXJS firmware in the field.

2. Extract the file (XXXX_machine), after which the "SDK" folder is created.

↓ Note

- Note: XXXX = part number.

3. Copy the "SDK" folder to an SD card.

-Main procedure-

1. Remove the card slot cover [A] for SD cards (🔧 x 1).
2. Insert the SD card included for firmware update into SD slot 2 [B].

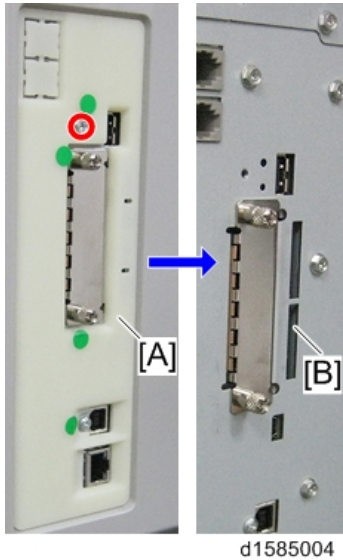

3. Turn the main switch on.
4. After the Update screen is displayed, select the "Browser".
5. Touch "Update (#)".
6. After the "Update Done" message appears on the screen, turn the main power switch OFF.
7. Remove the SD card from the lower slot.

Updating the Extended JavaScript

Do the following steps if you are updating the Extended JavaScript.

1. Turn the main switch on.
2. Push the [User Tools/Counter] key.
3. Touch "Extended Feature Settings" twice on the LCD.

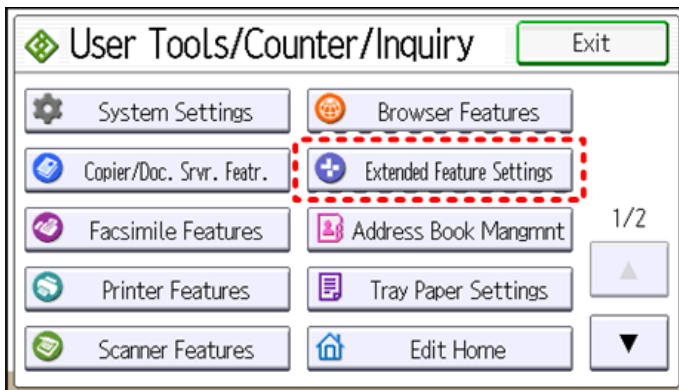

w_d1585058

4. Change the status of "Extended JS" to "Ending" in the Startup Settings tab.

5. Turn the main switch OFF.
6. Insert the SD card containing the Extended JS firmware into SD slot 2 (lower).
7. Turn the main switch on.
8. Push the [User Tools/Counter] key.
9. Touch "Extended Feature Settings" twice on the LCD.
10. Touch the "Install" tab.
11. Touch "SD card", then select "Extended JS" from the list of Extended Features.
12. Select "Machine HDD" as the "Install to" destination, then touch "Next".
13. Check the Extended Features information on the "Ready to Install" screen, then press "OK".
14. After "The following extended feature has already been installed. Are you sure you want to overwrite it?" is displayed, press "Yes".
15. Change the status of Extended JS to "waiting" in the Startup Settings tab.
16. Turn the main switch OFF.
17. Remove the SD card from slot 2 (lower slot).
18. Turn the main switch ON.
19. Press the "User Tools/Counter" key.
20. On the touch panel, touch "Extended Feature settings".
21. Touch "Extended Feature settings" in the Extended Feature settings Menu.
22. Make sure that the "Extended JS" has been updated to the latest version in the Startup Settings tab.

Un-installing EXJS Firmware

1. Turn the main switch ON.
2. Push the [User Tools/Counter] key.
3. Login with an administrator user name and password.
4. Touch "Extended Feature Settings" twice on the LCD.
5. Touch "Uninstall".
6. Touch "Browser", and then touch "Yes" after "Are you sure you want to uninstall the following extended feature?" is displayed.

Note

- "Uninstalling the extended feature... Please wait" is then displayed on the touch screen.

7. After "Completed" is displayed, turn the main power switch OFF

Note

- The Browser firmware is un-installed from the machine when the Browser SD card is removed.

Fax Connection Unit (D158/D159)

Installation Procedure

⚠ CAUTION

- Unplug the main machine power cord before you do the following procedure.

1. Remove the card slot cover [A] (🔧 x 1).
2. Insert the SD card into slot 1 [B].

↓ Note

- If slot 1 [B] is in use, move the application program to another SD card with SP5-873-001.

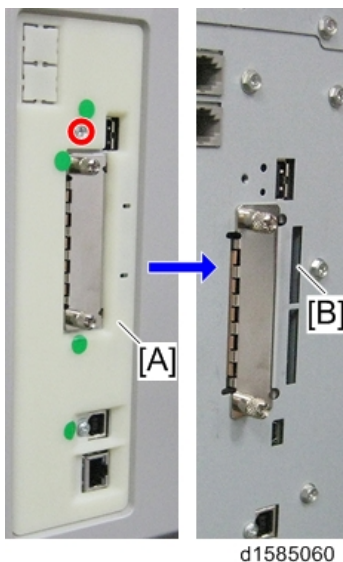

3. Plug in and turn on the main power switch.
4. Turn the main switch off.
5. Attach the card slot cover, and then turn on the machine (🔧 x 1).
6. Make sure that the machine can recognize the option (🖨 p.146 "Check All Connections").

SD Card for Netware Printing (D158/D159)

Installation Procedure

⚠ CAUTION

- Unplug the main machine power cord before you do the following procedure.

1. Remove the card slot cover [A] (🔧 x 1).
2. Insert the SD card (Netware Printing) in SD slot 1 [B].

Note

- If slot 1 [B] is in use, move the application program to another SD card with SP5-873-001.

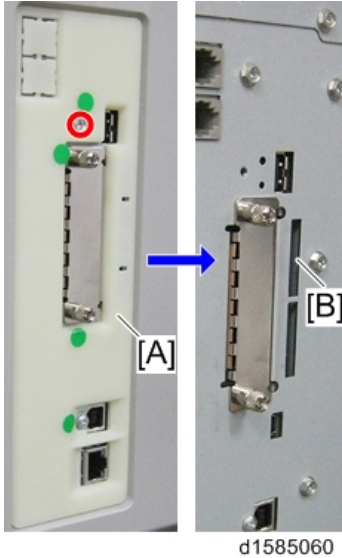

3. Plug in, and turn the main switch on.
4. Turn the main switch off.
5. Attach the card slot cover, and then turn the main switch on (🔧 x 1).
6. Make sure that the machine can recognize the option (🖨 p.146 "Check All Connections").

Bluetooth Interface Unit (D158/D159)

Installation Procedure

⚠ CAUTION

- Unplug the main machine power cord before you do the following procedure.
- Do not remove the Bluetooth unit while the power of the machine is on.

You can only install one of the following network interfaces at a time: (IEEE a/b/g (Wireless LAN), Bluetooth).

1. Insert the Bluetooth Interface adapter into the USB connector [A].



D1585061

2. Plug in, and turn the main switch on.
3. Make sure that the machine can recognize the option (☛ p.146 "Check All Connections").

Note

- The Bluetooth interface unit and the IC card can not be used simultaneously.

Wireless LAN Interface Unit (D158/D159)

Component Check

No.	Description	Q'ty	For this model
1	Wireless LAN Board	1	Yes
2	Velcro fasteners	2	Yes
3	Clamp	8	Yes

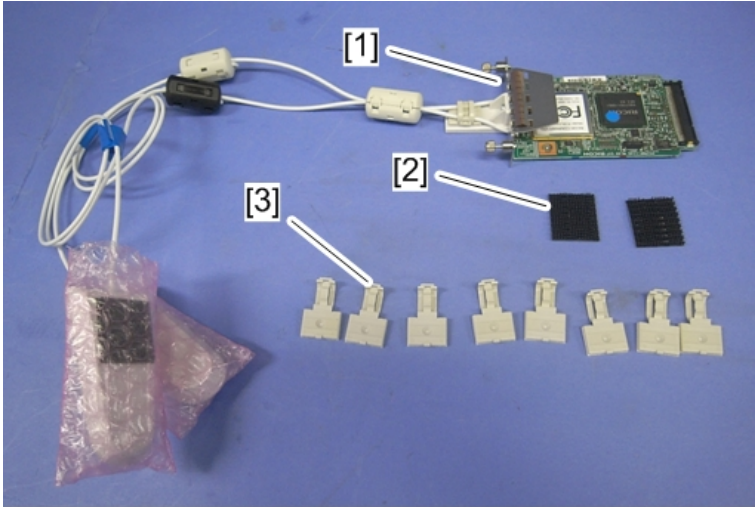

d1585028

Installation Procedure

⚠ CAUTION

- Unplug the main machine power cord before you do the following procedure.

1. Remove the slot cover [A] (⚙ x 2).
2. Install the Wireless LAN board [B] (2 knob screws).

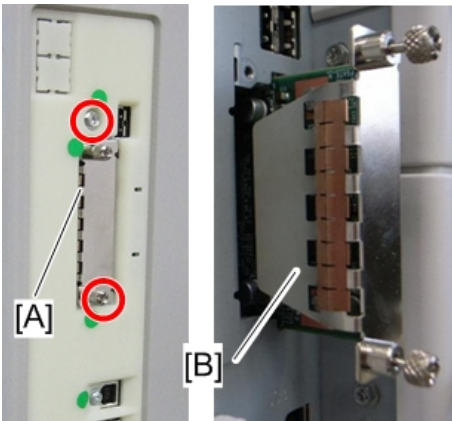

d1585005

3. Make sure that the machine can recognize the option (☑ p.146 "Check All Connections").
4. Peel off the double-sided tapes on the Velcro fasteners [A], and then attach "ANT1" (having a black ferrite core) [B] to the front left of the machine.

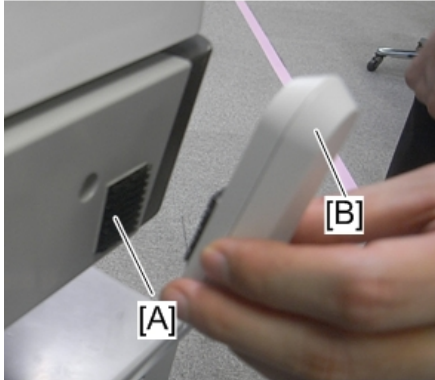

d1585014

5. Peel off the double-sided tapes on the Velcro fasteners [A], and then attach "ANT2" (having a white ferrite core) [B] to the rear right of the machine.

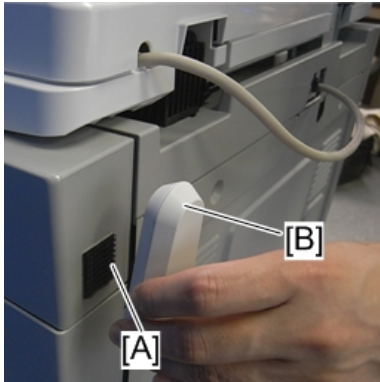

d1585015

Note

- "ANT1" is a transmission/reception antenna and "ANT2" is a reception antenna. Do not attach them at the wrong places.

6. Attach the clamps as shown above and then wire the cables and clamp them (🔧 x 6).

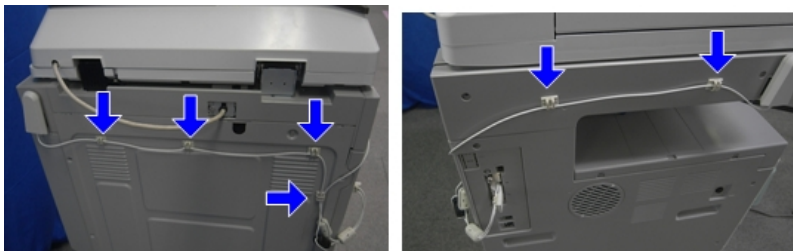

d1585016

Note

- Make sure that the cables are not loose. Keep them wired tightly along the covers.

- You may have to move the machine if the reception is not clear.
- Make sure that the machine is not located near an appliance or any type of equipment that generates strong magnetic fields.
- Install the machine as close as possible to the access point.

UP Mode Settings for Wireless LAN

Enter the UP mode. Then do the procedure below to perform the initial interface settings for IEEE 802.11 a/b/g. These settings take effect every time the machine is powered on.

↓ Note

- You cannot use the wireless LAN if you use Ethernet.

1. Press the [User Tools/Counter] key.
2. On the touch panel, press [System Settings].

↓ Note

- The Network I/F (default: Ethernet) must be set for either Ethernet or wireless LAN.

3. Select [Interface Settings].
4. Press "Wireless LAN". Only the wireless LAN options show.
5. Press "Communication Mode". Select either "802.11 Ad-Hoc Mode", or "Infrastructure Mode".
6. Press "SSID Setting". Enter the SSID setting. (The setting is case sensitive.)
7. Press "Ad-HocChannel". You need this setting when Ad Hoc Mode is selected.

Region A (mainly Europe and Asia)

Range: 1-13, 36, 40, 44 and 48 channels (default: 11)

In some countries, only the following channels are available:

Range: 1-11 channels (default: 11)

Region B (mainly North America)

Range: 1-11, 36, 40, 44 and 48 channels (default: 11)

8. Press "Security Method".
9. Enter the "WEP (Encryption) Key".
10. Press "Ethernet Speed." Press the Next button to show more settings. Then select the transmission speed.
11. Press "Return to Default" to initialize the wireless LAN settings.
12. Press "Yes" to initialize the following settings:
 - Transmission mode
 - Channel

- Transmission Speed
- WEP
- SSID
- WEP Key

SP Mode and UP Mode Settings for IEEE 802.11 a/b/g, Wireless LAN

2

The following SP commands and UP modes can be set for IEEE 802.11 a/b/g.

SP No.	Name	Function
5840-006	Channel MAX	Sets the maximum range of the channel settings for the country.
5840-007	Channel MIN	Sets the minimum range of the channels settings allowed for your country.
5840-011	WEP Key Select	Used to select the WEP key (Default: 00).
UP mode	Name	Function
	SSID	Used to confirm the current SSID setting.
	WEP Key	Used to confirm the current WEP key setting.
	WEP Mode	Used to show the maximum length of the string that can be used for the WEP Key entry.

IEEE 1284 Interface Board (D158/D159)

Installation Procedure

CAUTION

- Unplug the main machine power cord before you do the following procedure.

You can only install one of the following network interfaces at a time: (IEEE 802.11 a/b/g (Wireless LAN), IEEE 1284)

1. Remove the slot cover [A] ( x 2).
2. Install the IEEE 1284 I/F board [B] into the board slot and then fasten it with screws.

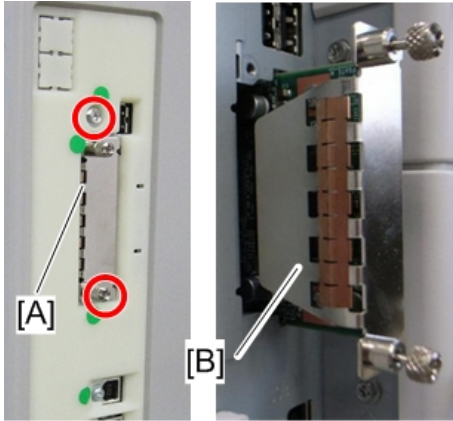

d1585005

3. Make sure that the machine can recognize the option (☑ p.146 "Check All Connections").

Fax Unit (D158/D159)

Component Check

Check the quantity and condition of the components against the following list.

No.	Description	Q'ty
1	FCU	1
2	Telephone Cable (NA only)	1
3	Screw	6
4	Fax Decal for Operation Panel	1
5	Board Cover	1
6	Grounding Plate (2-tip)	1
7	Grounding Plate (3-tip)	1
8	EMC Address (EU only)	1
9	Serial Number Decal	1
10	FCC Decal (NA only)	1
-	Installation Procedure (NA only)	1

No.	Description	Q'ty
-	RoHS Decal (China only)	1
-	RoHS Date Decal (China only)	1

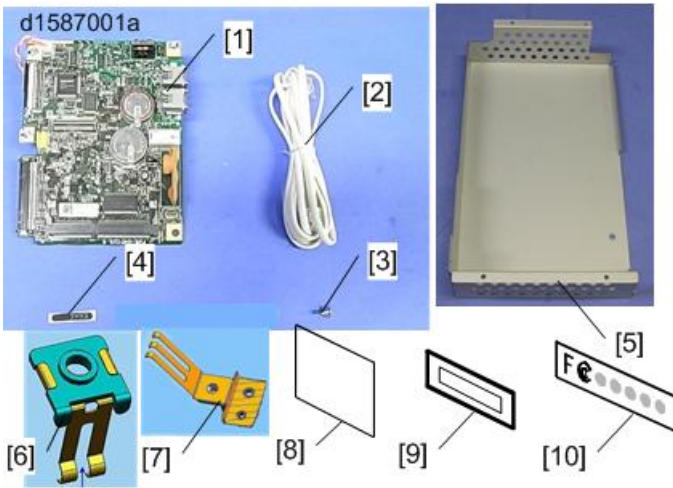

Installation Procedure

⚠ CAUTION

- Unplug the main machine power cord before you do the following procedure.

1. Rear cover [A] (⚙ x 9)

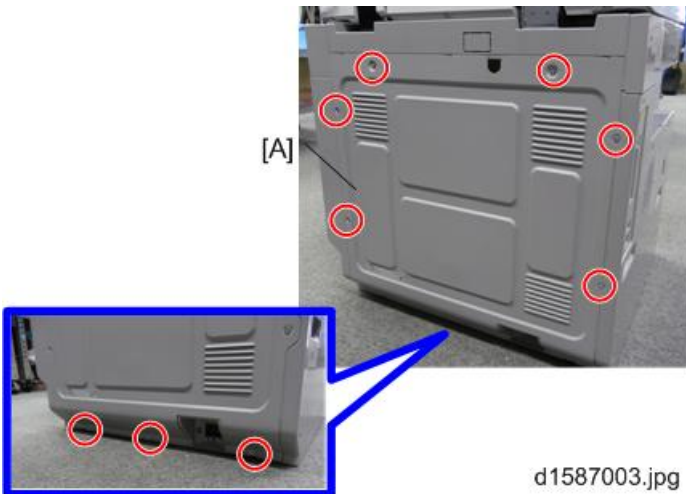

2. Five screws

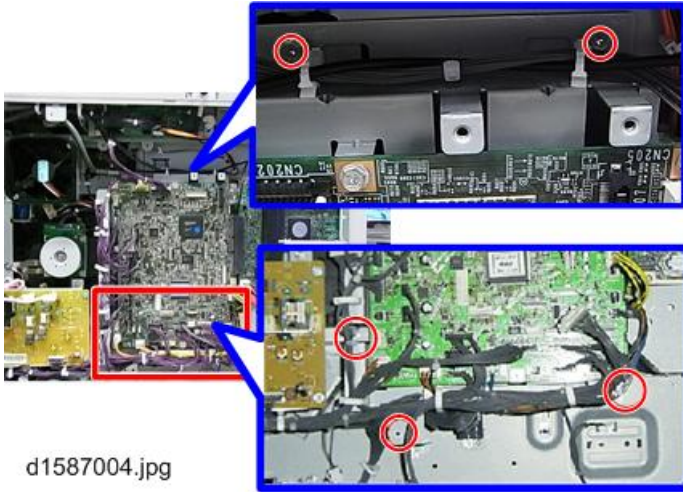

3. Slide the engine board [A] to the left as shown, to detach it from the controller board [B].

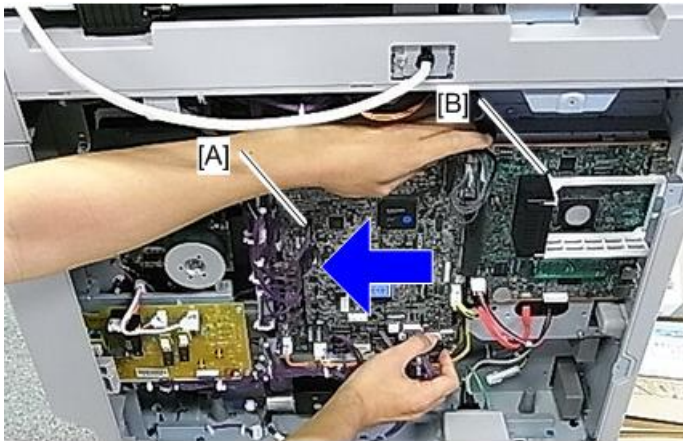

4. Controller slot cover [A] (⚙️ x1)

5. Four screws [B]

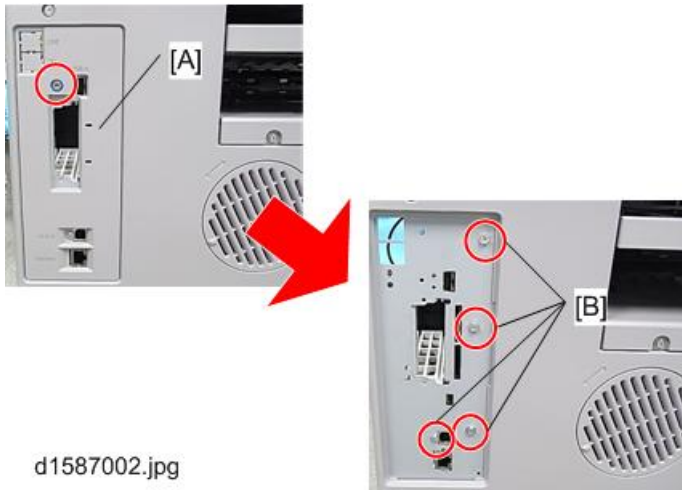

6. Three screws

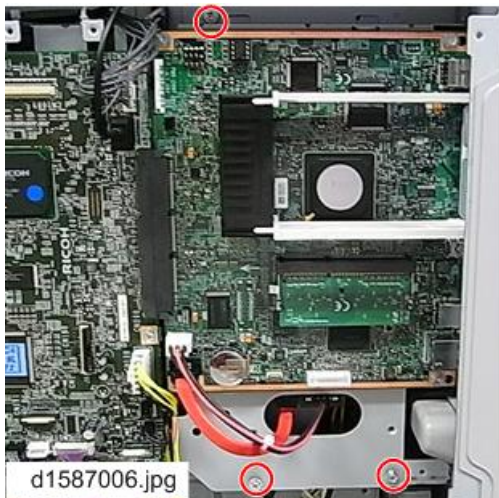

7. Slide the controller board [A] to the left and pull as shown.

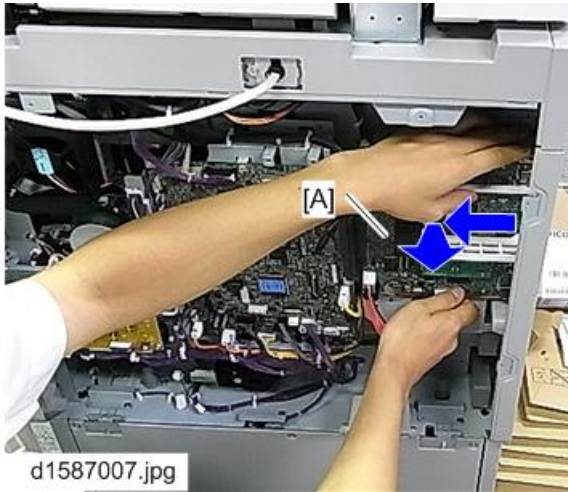

8. Detach the FCU from the speaker bracket (⚙️ x 3)
9. Insert the grounding plate (3-tip) [A] between the bracket and the FCU.
10. Reattach the FCU.

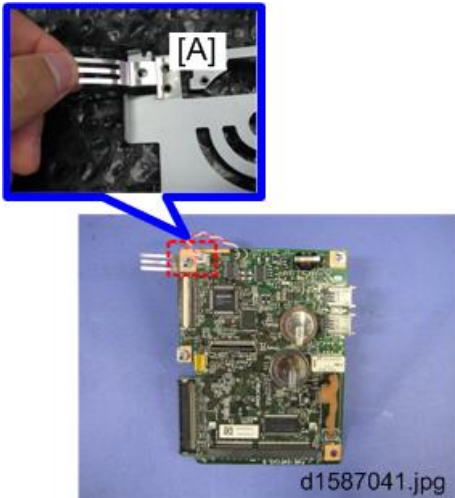

11. Attach the grounding plate (2-tip) [A] on the back of the FCU (⚙️ x1).

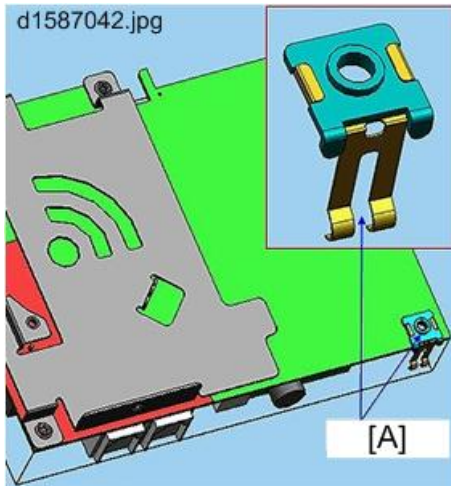

12. Attach the FCU to the controller board as shown.

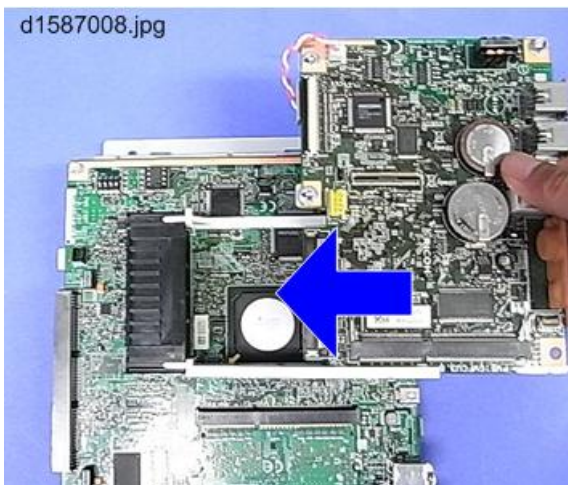

Note

- Make sure that the **FCU** is seated correctly. If not, SC672 occurs.

13. Remove the jumper [A] (set to OFF) and set it to ON.

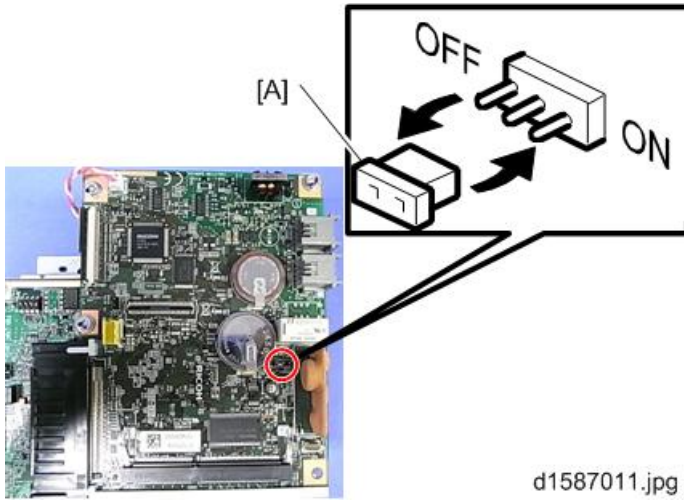

Note

- The machine may issue SC819 or SC820 if the jumper is not set to "ON" correctly.
- For installation in Brazil, move the jumper switch (CN613) from "3" to "1"

14. Cut the knockouts for LINE and TEL from the controller slot cover.

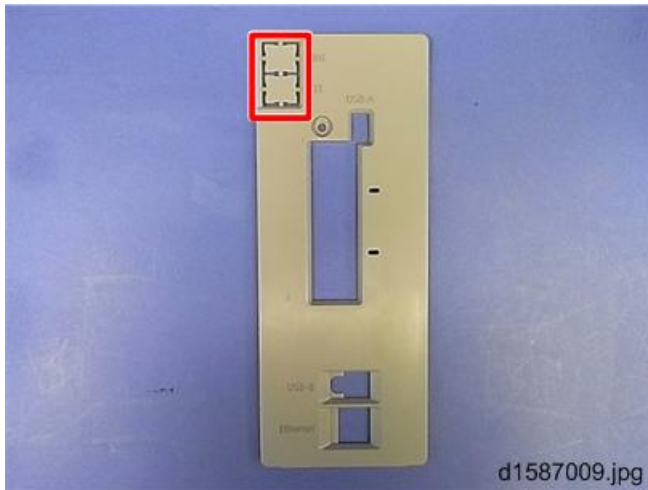

15. Install the controller board in the machine

16. Fasten the five circled screws.



Note

- The arrow in the picture above indicates the screw to fasten the FCU.

17. Attach the board cover [A] as shown below. (⚙️ x 4)

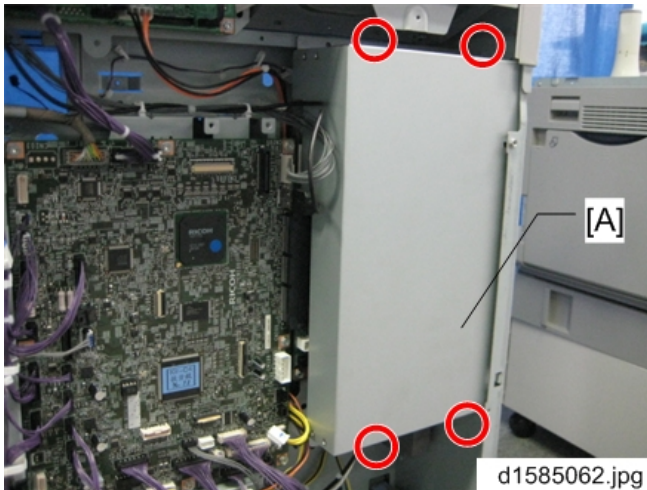

18. Connect the telephone cord to the LINE jack.

19. Attach the Fax decal on the operation panel.

Fax Settings

Initializing the Fax unit

When you press the Fax key for the first time after installation, the error "SRAM problem occurred / SRAM was formatted" will show on the LCD for initializing the program of the fax unit. Turn the main power switch off/on to clear the error display.

Note

- If another error occurs after initialization, this can be a functional problem.
1. Select fax SP1-101-016 and specify the country code.
 2. Select fax SP3-101-001 and specify the service station if necessary.

Memory Unit (D158/D159)

Installation Procedure

CAUTION

- Unplug the main machine power cord before you do the following procedure.
1. Rear cover (p.152)
 2. Replace the 1 GB memory unit in the slot [A] on the controller board with the optional 1.5 GB memory unit.

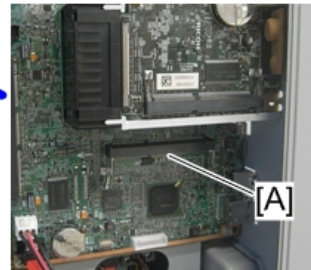
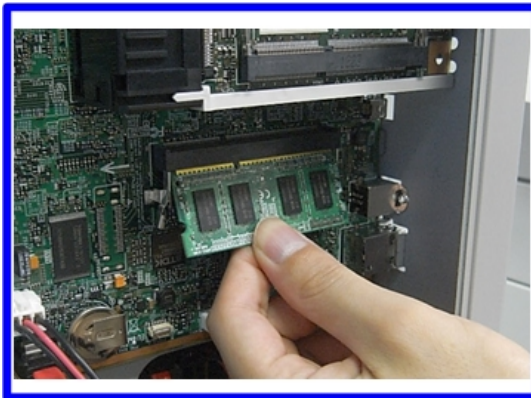

d1585013

3. Reassemble the machine.

Handset (D158/D159)

Component Check

Check the quantity and condition of the components against the following list.

No.	Description	Q'ty
1	Bracket	1

No.	Description	Q'ty
2	Cradle	1
3	Handset	1
4	Round Screw (for cradle)	2
5	Tapping Screw (for upper left cover)	2

2

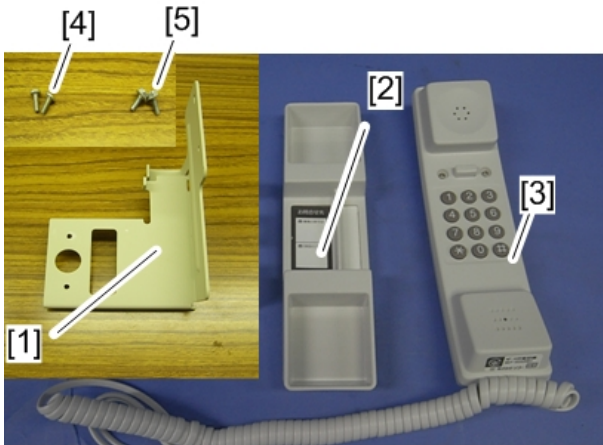

d1585018

Installation Procedure

1. Make two screw holes in the upper left cover.

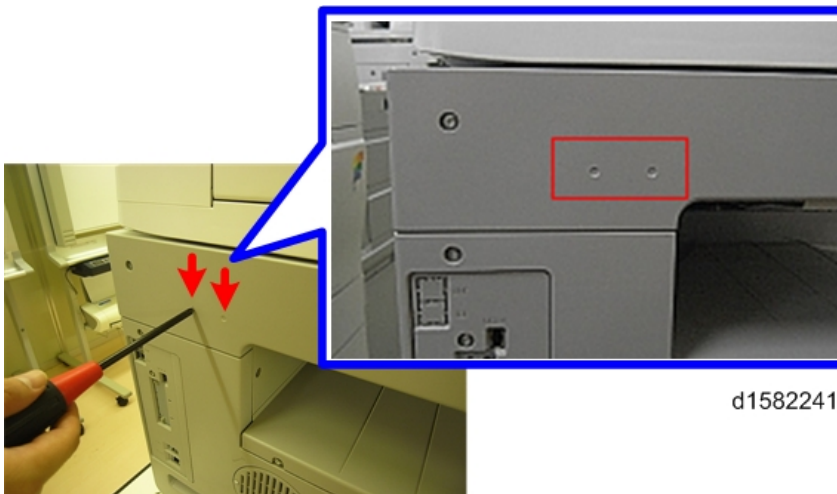

d1582241

2. Attach the cradle [A] to the bracket [B] (Round screw x 2).

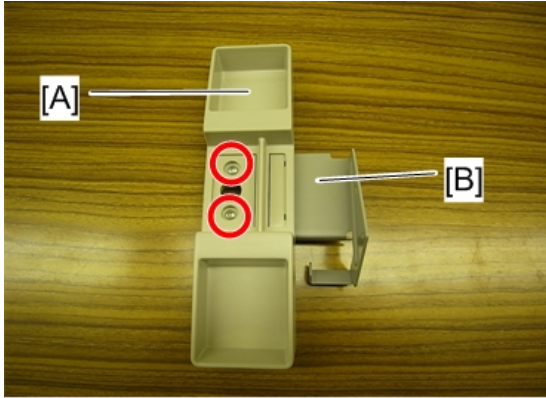

d1582242

- 3. Attach the cradle to the upper left cover (Tapping screw x 2).



d1582243

- 4. Cut the knockouts for TEL and LINE.

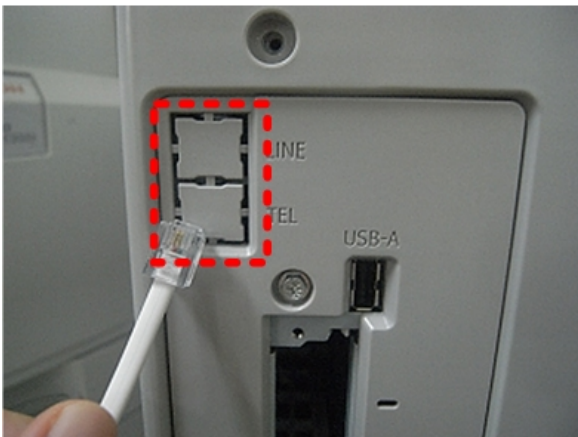

d1585024

- 5. Install the hand set [A] and TEL cable.



d1582244

2

IC Card (D158/D159)

Installation Procedure

1. Exit rear cover, Output tray (☛ p.152)
2. Front cover (☛ p.159)
3. Remove the card slot cover [A] (☛ x 1).

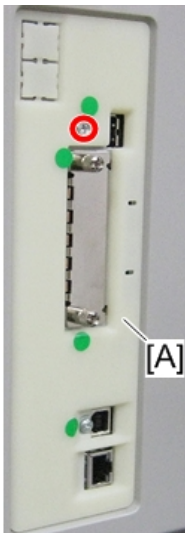

d1582250

4. Cut the knockout [A] from the card slot cover for USB cable.

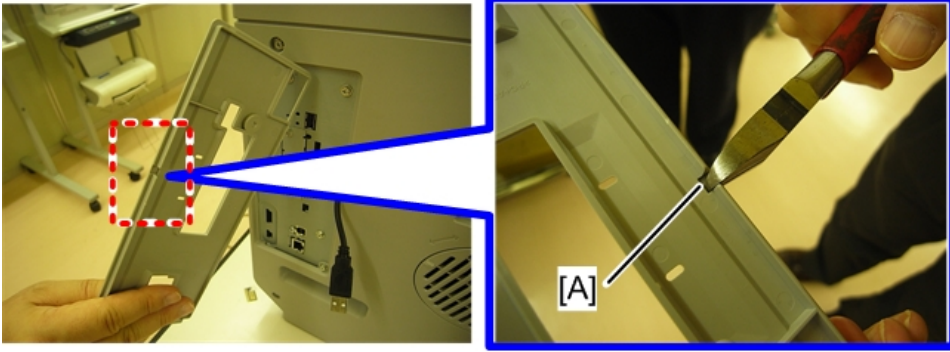

d1582248

5. Attach the IC card [A] to the IC card holder with the bracket [C] at the rear side of the output tray (④ x 1).

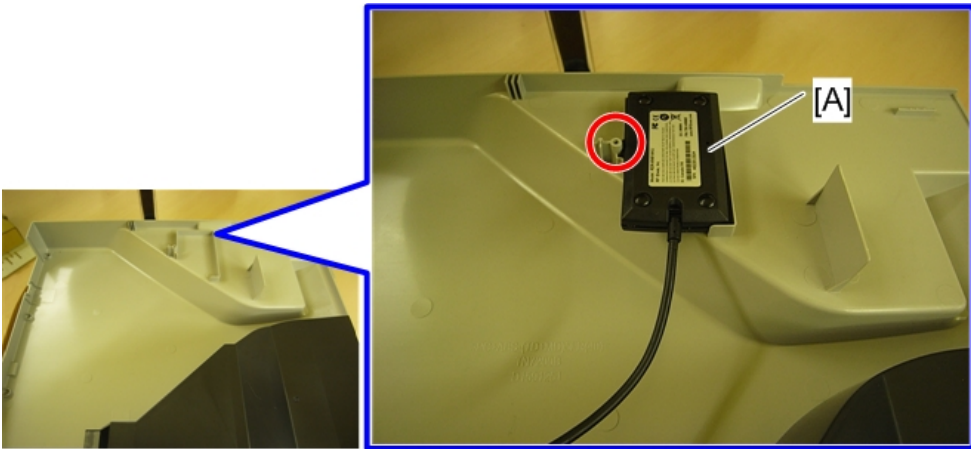

d1582245



d1585063

- Route the USB cable [A] through the cutout [B] on the interface flame from as shown below.

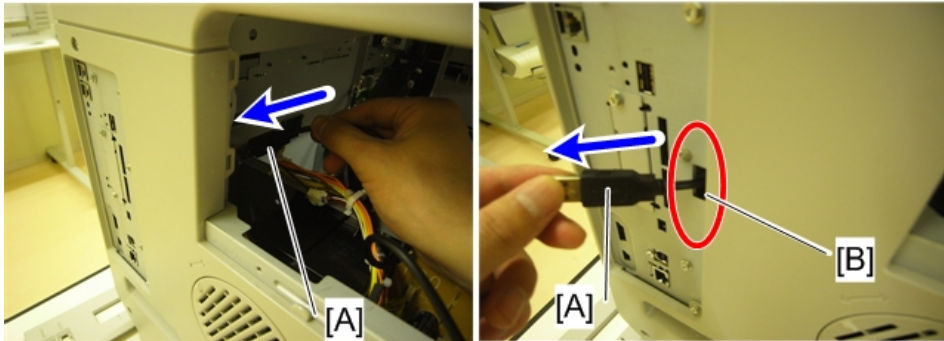

d1582246

- Attach the card slot cover and connect the USB cable.



d1582247

- Adjust and store the USB cable at the left side of the laser unit.



d1582249

- Reassemble the machine.
- Attach the IC card decal to the position [A] on the output tray.

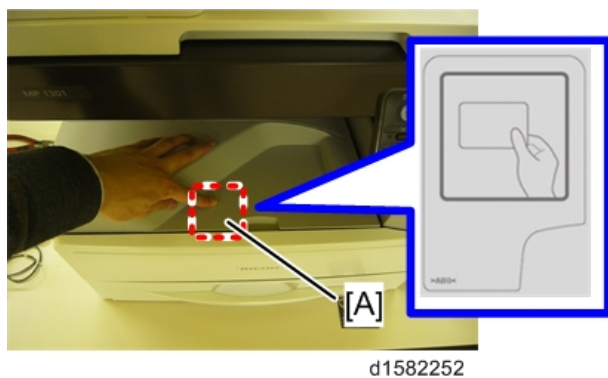

Check All Connections

1. Plug in, and turn the main switch on.
2. Enter the printer user mode. Then print the configuration page.

User Tools → Printer Features → List Test Print → Configuration Page

All installed options are shown in the "System Reference" column.

3. Preventive Maintenance

PM Tables

See "Appendices" for the following information:

- Appendix: PM Tables

How to Reset the PM Counter

After preventive maintenance work, reset the PM counter (SP7-804) as follows.

D160/D161/D170 Models

1. Activate the SP mode (▶▶▶ p.299 "Service Program Mode").
2. Select SP7-804 (PM Counter Reset).
3. Select SP7-804-002 (60k) or SP7-804-003 (120k).
4. Press the OK key. The message "Execute" shows.
5. Press the button below the message "Execute."
6. The messages "Execute?" followed by "Cancel" and "Execute" show.
7. To reset the PM counter, press the button below the message "Execute."
8. Wait until the message "Completed" shows.
9. Quit the SP mode.

D158/D159 Models

1. Activate the SP mode (▶▶▶ p.299 "Service Program Mode").
2. Select SP7-804 (PM Counter Reset).
3. Select SP7-804-002 (60k) or SP7-804-003 (120k).
4. Press the "Execute" button.
5. Wait until the message "Completed" shows.
6. Quit the SP mode.

4. Replacement and Adjustment

General Cautions

Do not turn off the main switch while any of the electrical components are active. Doing so may result in damage to units (such as the PCU) as they are pulled out or replaced.

Main Power Switch (Push SW)

If the AC power cord is connected, power is supplied to the controller, control panel, and the circuit that detects the main power switch status even if the main power is turned off.

Therefore, even if the machine has shut down, the power is still supplied to the interior components. If you attempt to replace the controller or control panel in such a state, the related components may become damaged.

Be sure to pull off the AC power cord before replacing components (such as a circuit board).

PCU (Photoconductor Unit)

The PCU consists of the OPC drum, charge roller, development unit, and cleaning components. Observe the following precautions when handling the PCU.

1. Never touch the drum surface with bare hands. If the drum surface is dirty or if you have accidentally touched it, wipe it with a dry cloth, or clean it with wet cotton and then wipe it dry with a cloth.
2. Never use alcohol to clean the drum. Alcohol will dissolve the drum surface.
3. Store the PCU in a cool dry place.
4. Do not expose the drum to corrosive gases (ammonia, etc.).
5. Do not shake a used PCU, as this may cause toner and developer to spill out.
6. Dispose of used PCU components in accordance with local regulations.

Transfer Roller

1. Never touch the surface of the transfer roller with bare hands.
2. Be careful not to scratch the transfer roller, as the surface is easily damaged.

Scanner Unit

1. Use alcohol or glass cleaner to clean the exposure and scanning glass. This will reduce the static charge on the glass.
2. Use a blower brush or a water-moistened cotton pad to clean the mirrors and lenses.
3. Make sure to not bend or crease the exposure lamp's ribbon cable.
4. Do not disassemble the lens unit. This will cause the lens and copy image to get out of focus.
5. Do not turn any of the CCD positioning screws. This will put the CCD out of position.

Laser Unit

1. Do not loosen or adjust the screws securing the LD drive board on the LD unit. This will put the LD unit out of adjustment.
2. The polygonal mirror and F-theta lens are very sensitive to dust.
3. Do not touch the toner shield glass or the surface of the polygonal mirror with bare hands.

Fusing Unit

1. After installing the fusing thermistor, make sure that it is in contact with the hot roller and that the roller can rotate freely.
2. Be careful to avoid damage to the hot roller stripper pawls and their tension springs.
3. Do not touch the fusing lamp and rollers with bare hands.
4. Make sure that the fusing lamp is positioned correctly and that it does not touch the inner surface of the hot roller.

Paper Feed

1. Do not touch the surface of the paper feed rollers.
2. To avoid misfeeds, the side and end fences in each paper tray must be positioned correctly so as to align with the actual paper size.

★ Important

- You must run SP2-801-001 (Developer Initialization) to initialize the TD sensor after you install a new PCU. After starting initialization, be sure to wait for it to reach completion (wait for the motor to stop) before you re-open the front cover or turn off the main switch.
- If the optional tray heater or optics anti-condensation heater is installed, keep the machine's power cord plugged in even while the main switch is off, to keep the heater(s) energized.

Special Tools and Lubricants

Item	Part Number	Description	Q'ty	Unique or Common
1	B6455010	SD Card	1	C (General)
2	52039502	Silicone Grease G-501	1	C (General)
3	B6795100	Plug - IEEE1284 Type C	1	C (General)
4	A2929500	Test Chart-S5S (10pc./set)	1	C (General)
5	A0069104	Scanner Positioning Pin (4pc./set)	1	C (General)
6	G0219350	Loop-back Connector – Parallel ^{*1}	1	C (General)

*1 : Loop-back Connector – Parallel (item 6) requires Plug - IEEE1284 Type C (item 3).

Exterior Covers & Operation Panel

★ Important

- Unplug the machine power cord before starting the following procedures.

Rear Cover

1. Rear cover [A] (🔩 x 9)

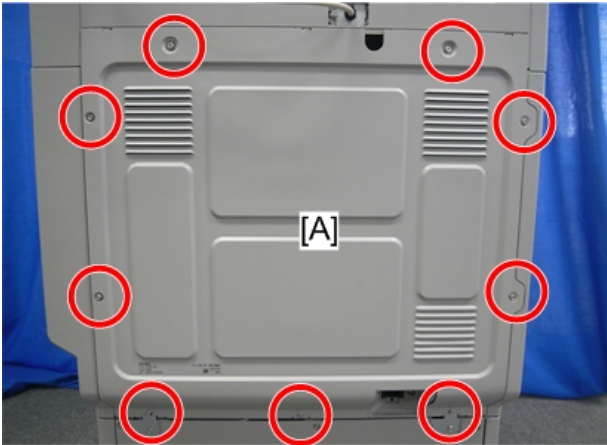

d1582005

Output Tray, Exit Cover, Exit Rear Cover

1. Front right cover (🔩 p.160)
2. Exit rear cover [A] (🔩 x 2)

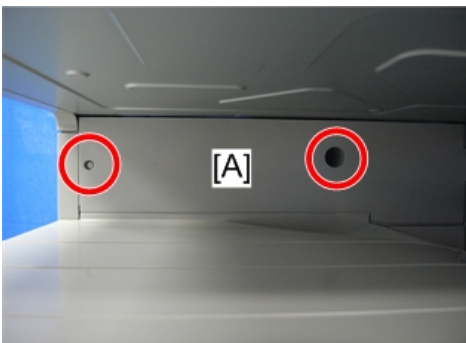

d1582023

3. Output tray [A] (🔩 x 2)

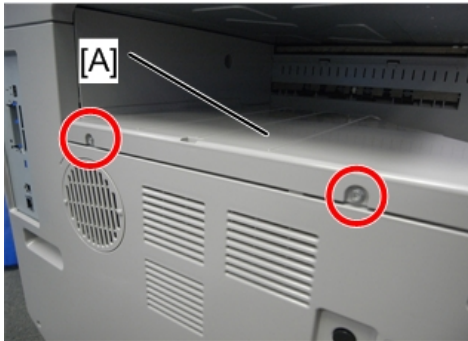

d1582024

4. Exit cover [A] (🔩 x 1)

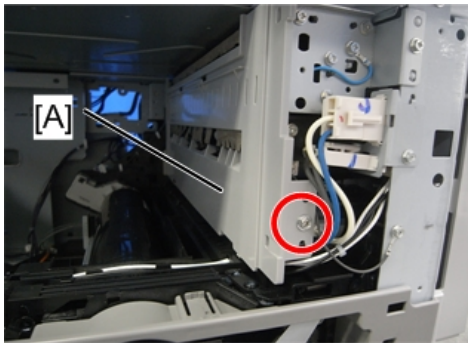

d1582025

Upper Covers (D158/D159)

1. Platen cover, or ARDF (if installed)
2. Rear cover (🔩 p.152)
3. Left upper cover [A] (🔩 x 2)

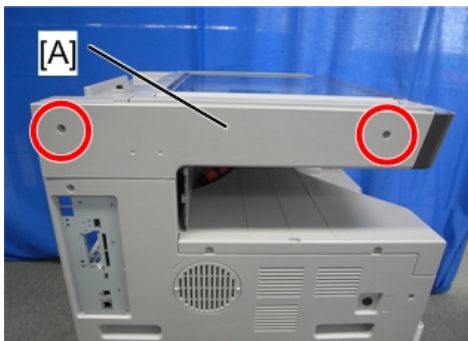

d1582026

4. Right upper cover [A] (🔩 x 2)

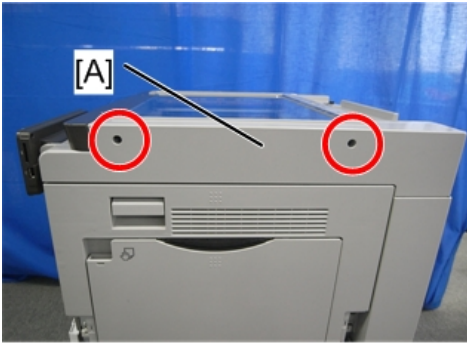

d1582027

4

5. Front top cover [A] (🔩 x 2)

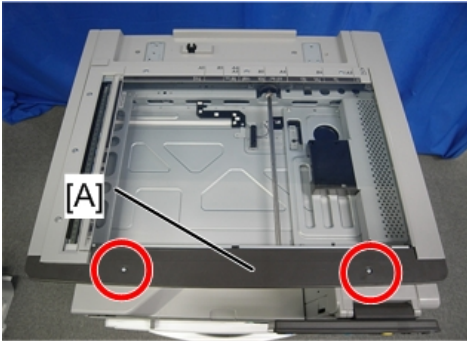

d1582028

6. Top rear cover [A] (🔩 x 2)

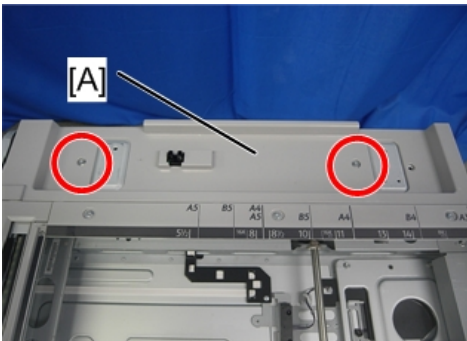

d1582029

Operation Panel (D158/D159)

1. Rear cover (🔩 p.152)
2. Front right cover (🔩 p.160)

3. Front top cover, right upper cover (☞ p.153 "Upper Covers (D158/D159)")
4. Operation panel upper cover [A]

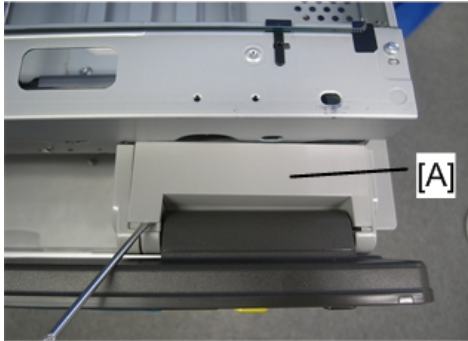

d1582034

5. Operation panel lower cover [A] (☞ x 1)

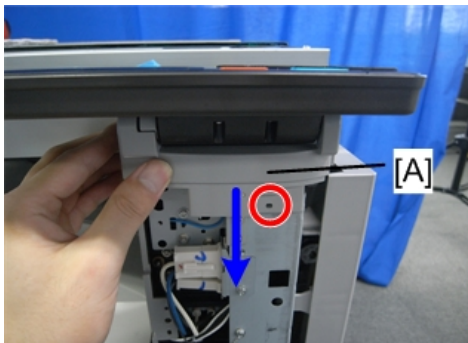

d1582035

6. Operation panel [A] (☞ x 5, ☞ x 1, USB x 1, ☞ x all)

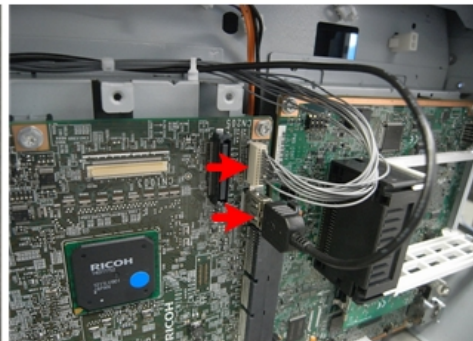
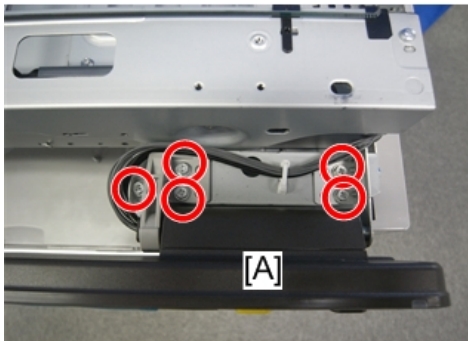

d1582036

Upper Covers (D160/D161/D170)

1. Platen cover, or ARDF (if installed)

2. Inverter tray [A]



d1582059

4

3. Right upper cover [A] ( x 2)

4. Left upper cover [B] ( x 2)

5. Top rear cover [C] ( x 2)

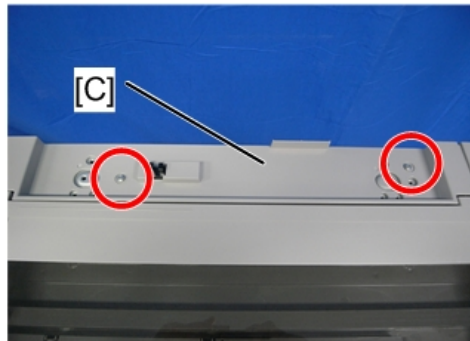
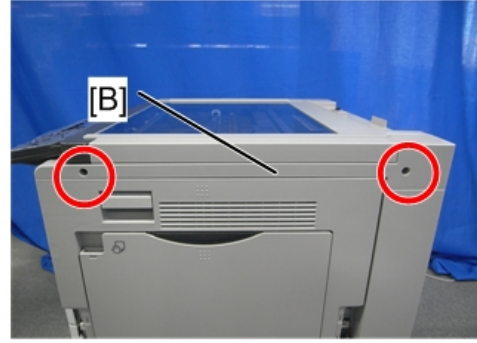
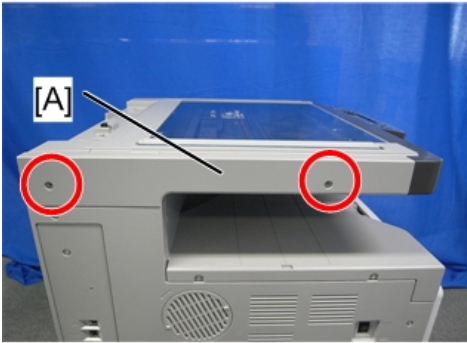

d1582058

6. Front top cover [A] (Hook x1)

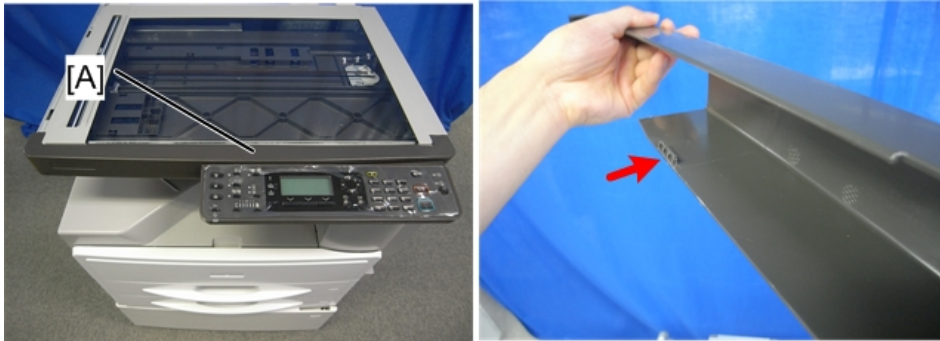

d1582060

4

Operation Panel (D160/D161/D170)

1. Platen cover, or ARDF (if installed)
2. Rear cover (● p.152)
3. Right upper cover (● p.155 "Upper Covers (D160/D161/D170)")
4. Left upper cover (● p.155 "Upper Covers (D160/D161/D170)")
5. Front top cover (● p.155 "Upper Covers (D160/D161/D170)")
6. Operation panel [A] (🔧 x 2, 📄 x 1)



d1582061

7. OPU board ( x 10, FFC x2, Hook x 2)

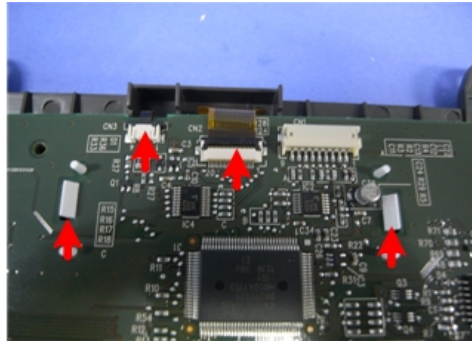
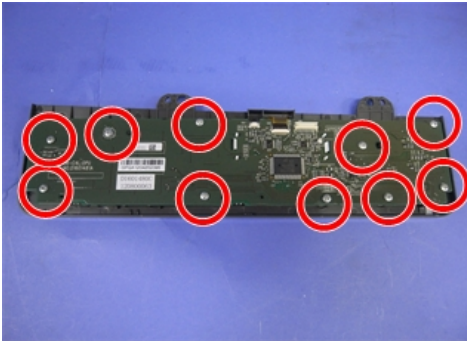

d1582062

Left Cover

1. Front right cover ( p.160)
2. Output tray ( p.152)
3. Left cover [A] ( x 5)

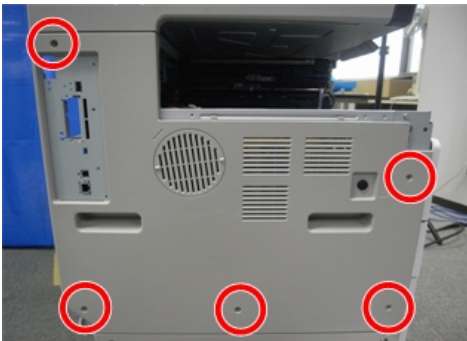

d1582030

Front Cover

1. Front door [A] (Hook x 2)

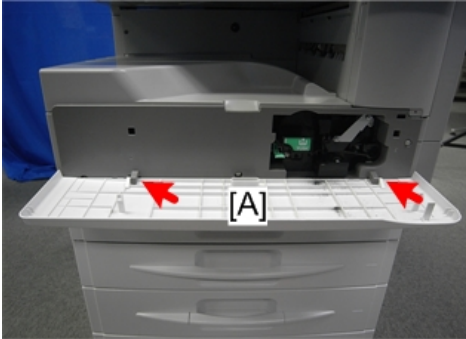

d1582031

2. Open the duplex unit and tray 1.
3. Front cover [A] (⚙️ x 3)

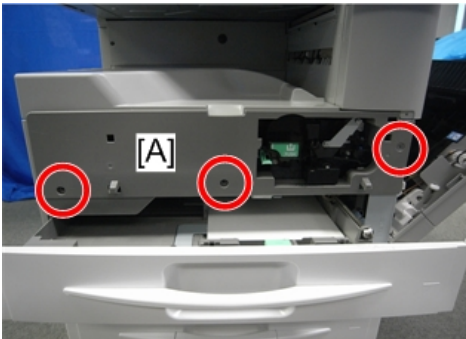

d1582032

Front Cover Switch (Interlock Switch)

1. Front door, front cover (🔑 p.159)
2. Metal plate [A] (⚙️ x 1)

3. Front cover switch [B] ( x 2)

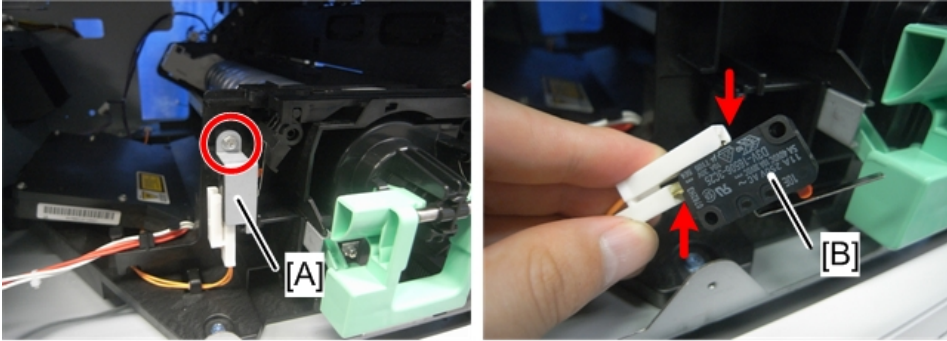

d1582126

Front Right Cover

1. Open the front door and duplex unit.
2. Front right cover [A] ( x 1)

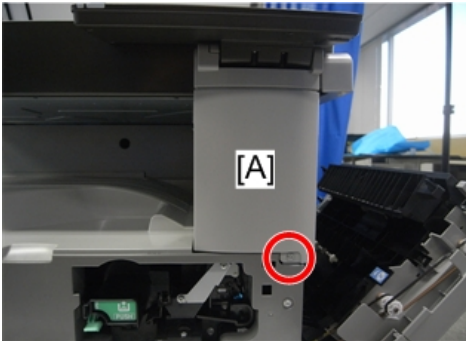

d1582022

Right Rear Cover

1. Open the duplex unit.

2. Right Rear Cover [A] (🔩 x 2) If you have difficulty to remove the lower screw, close the duplex unit and remove the cover [B] to unscrew.

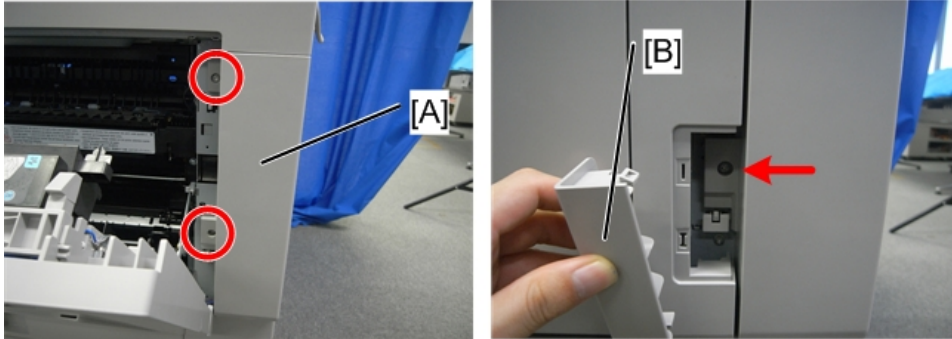

d1582033

4

Duplex Unit (D158/D159/D160/D161) / Right Door (D170)

1. Rear cover (🔩 p.152)
2. Right rear cover (🔩 p.160)
3. Open the duplex unit.
4. Four connectors (🔌 x 4)

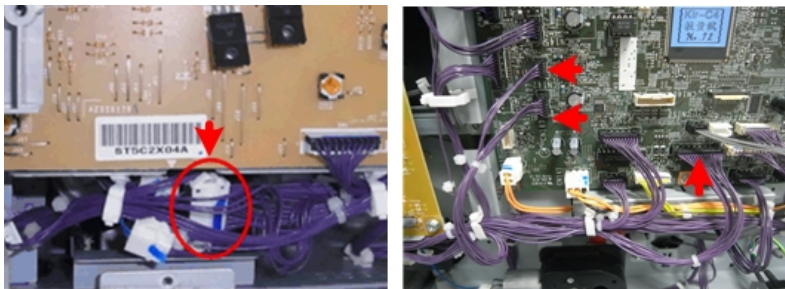

d1582038

5. Five clamps (🔗 x 5)

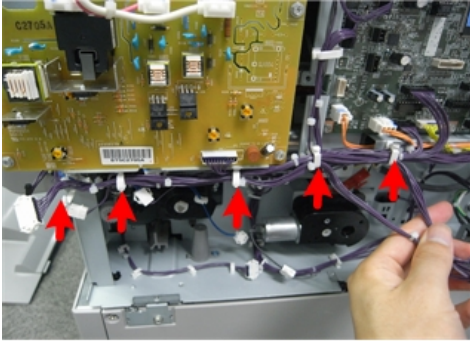

d1582201

4

6. One clip ring (🔗 x 1)

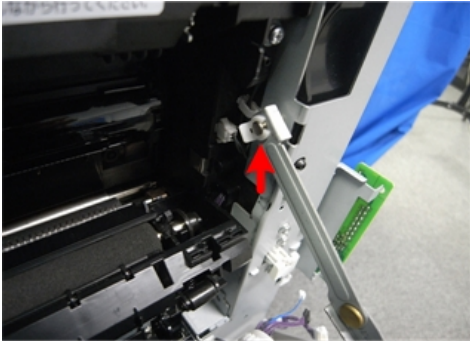

d1582202

7. Duplex unit [A]

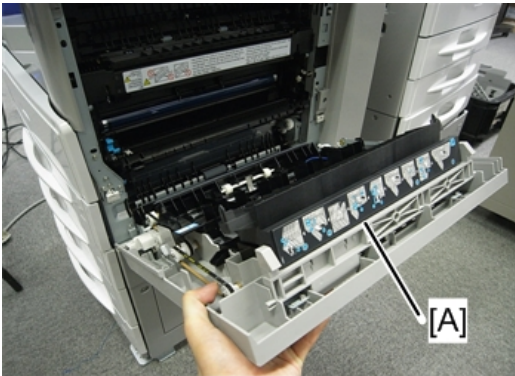

d1582272

By-pass Tray

1. Right rear cover (🔗 p.160)

2. Open the duplex unit.

3. Two clip rings (🔗 x 2)

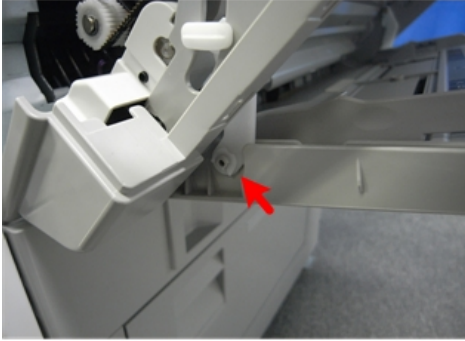

d1582039

4. One connector (🔌 x 1)

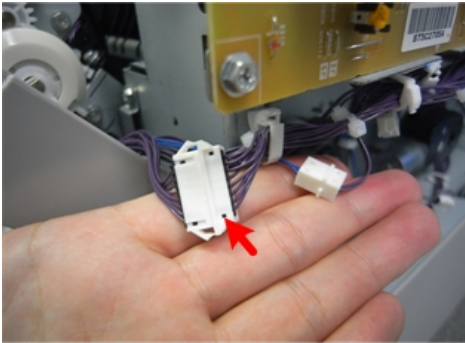

d1582040

5. Push the lock [A] and release the shaft to remove the by-pass tray [B].

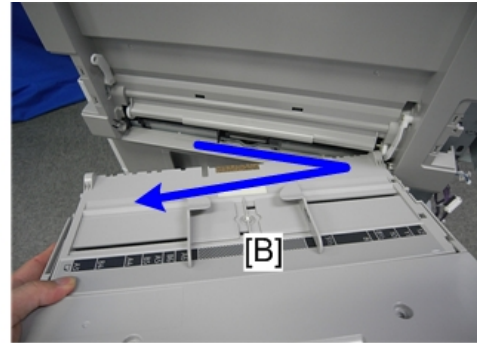
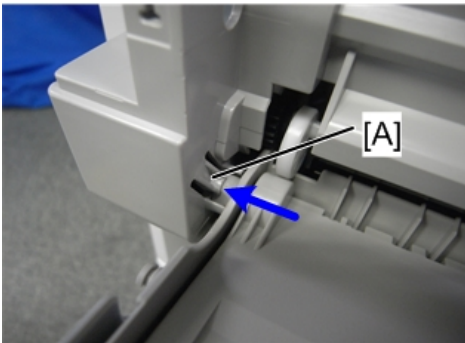

d1582203

Right Lower Cover (Two-tray Models Only)

1. Right lower cover [A] with inner cover [C] (Ⓜ[B] x 1).

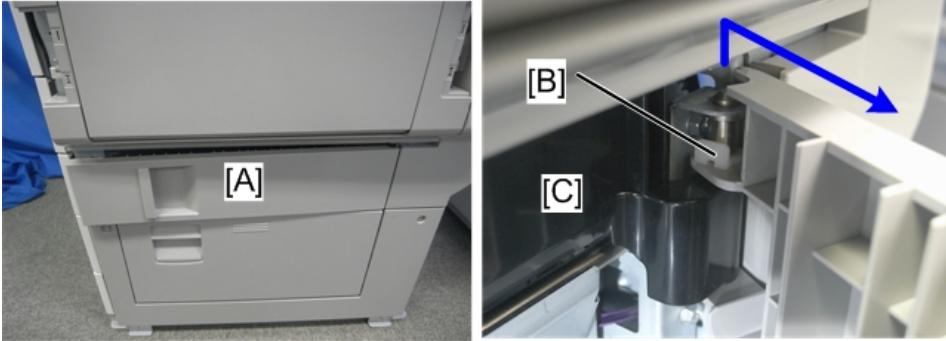

d1582090

Right Lower Cover Switch (Two-tray Models Only)

1. Remove the paper tray 1, and 2.
2. Open the right lower cover [A].
3. Right door switch [B] (Hook x 2)

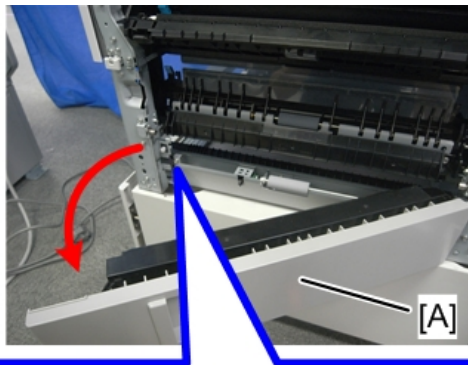

d1582125

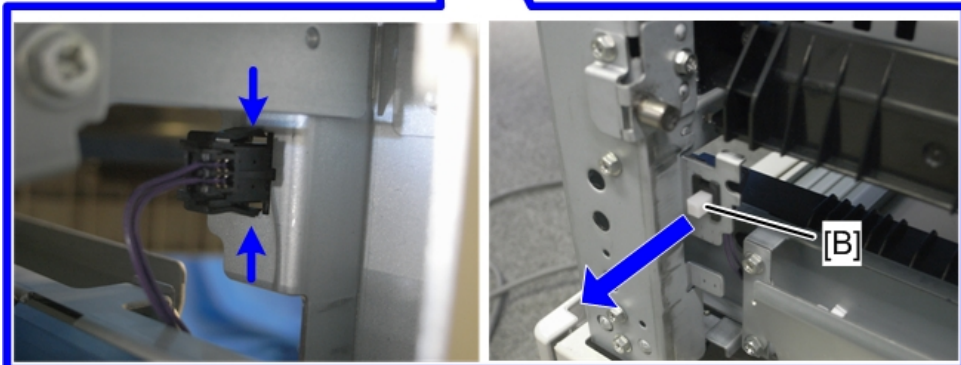

Platen Cover Sensor

1. Platen cover, or ARDF (if installed)
2. Top rear cover [A] (🔩 x 2)

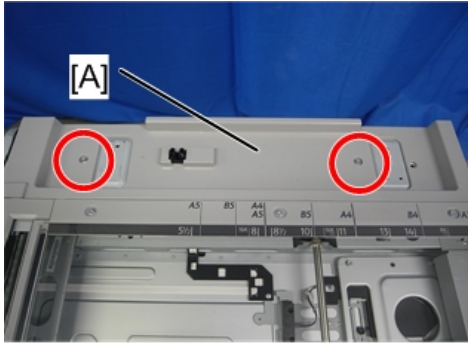

d1582029

3. Platen cover sensor [A] (🔩 x 1, 📏 x 1)

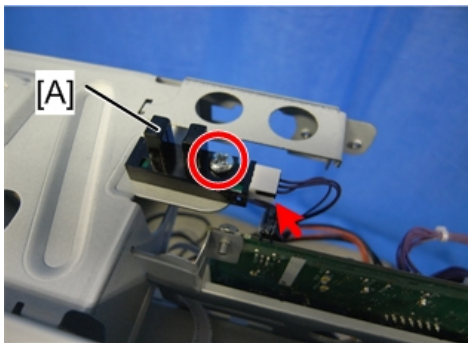

d1582037

Scanner Unit (D158/D159)

★ Important

- Unplug the machine power cord before starting the following procedures.

↓ Note

- CCD Scanner - D158/D159
- CIS Scanner - D160/D161/D170

When reassembling

- Adjust the following SP modes after you replace the scanner unit or each part of the scanner unit:
- SP4-008-001 (Sub Scan Magnification Adj): (☛ p.258 "Copy Adjustments Printing/Scanning")
- SP4-010-001 (Sub Scan Registration Adj): (☛ p.258 "Copy Adjustments Printing/Scanning")
- SP4-011-001 (Main Scan Reg): (☛ p.258 "Copy Adjustments Printing/Scanning")
- SP4-688-001 (DF: Density Adjustment): Use this to adjust the density level if the image density of outputs made in the DF and Platen mode is different.

4

Exposure Glass/DF Exposure Glass (CCD)

1. Front top cover, Right upper cover (☛ p.153 "Upper Covers (D158/D159)")
2. Rear scale [A] (☛ x 3)
3. DF exposure glass guide [B] (☛ x 3)

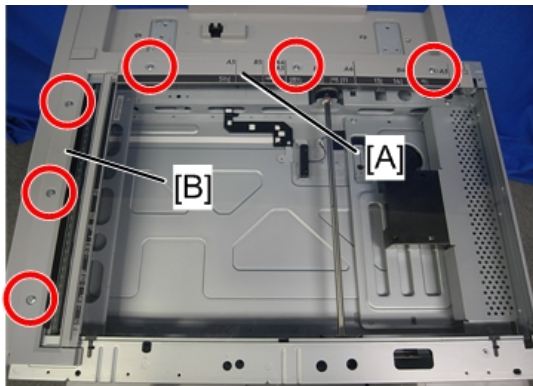

d1582041

4. DF exposure glass [A]

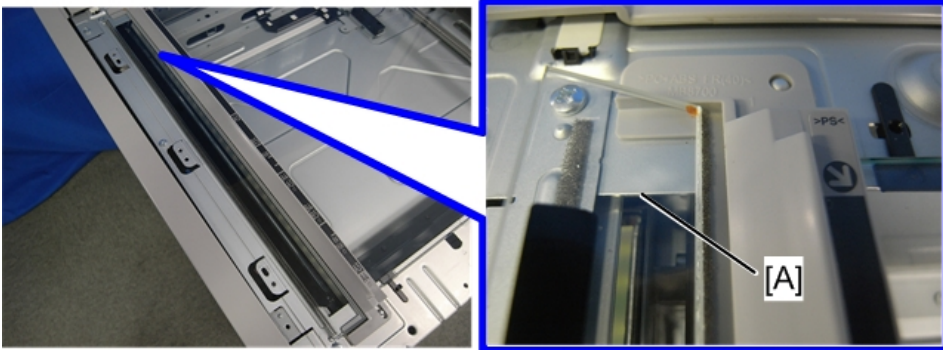

d1582042

5. Exposure glass [A]

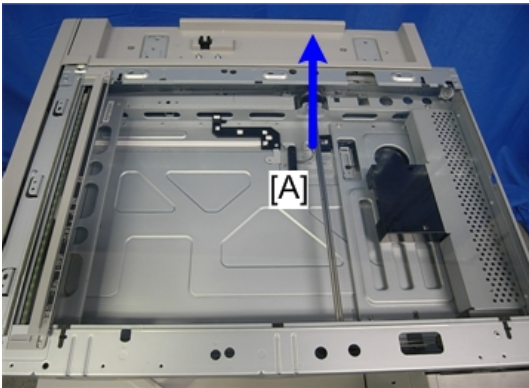

d1582043

↓ Note

- **When reassembling**
- The D158/D159 models with ARDF (D684) use a non-contact method to read originals from the ARDF. To avoid direct contact between originals and the DF exposure glass, the mylar [A] is attached to the DF exposure glass.
- Position the marking [B] as shown below when you install the DF exposure glass.

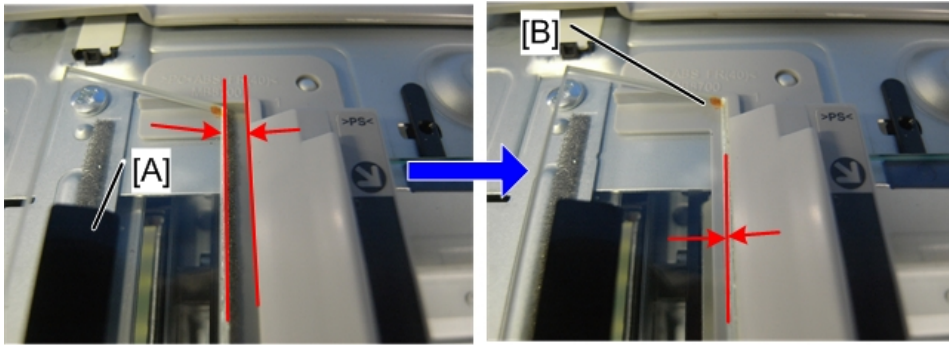

d1582044

4

Lens Block

⚠ CAUTION

- Do not touch the paint-locked screws on the lens block. The position of the lens assembly (black part) is adjusted before shipment.
- Do not grasp the PCB or the lens assembly when you handle the lens block. The lens assembly may slide out of position.

1. Exposure glass (☞ p.166 "Exposure Glass/DF Exposure Glass (CCD)")
2. Lens cover [A] (🔧 x 2)

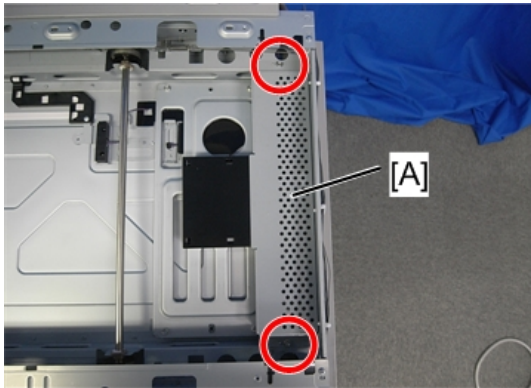

d1582045

3. Lens block [A] (🔩 x 4, 🛠️ x 2)

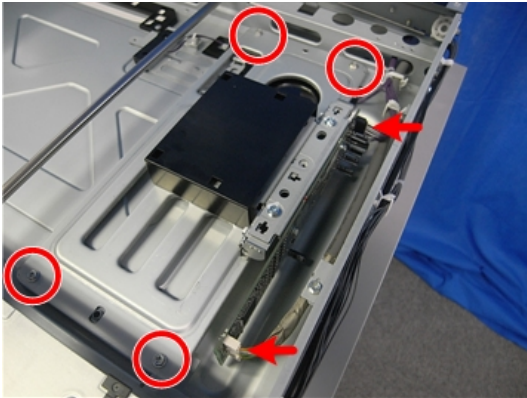

d1582046

⚠️ Note

- Do not remove the other screws on the lens block unit.

4

SIO Board

1. Rear cover (🔩 p.152)
2. SIO board with bracket [A] (🔩 x 1, 🛠️ x 6)

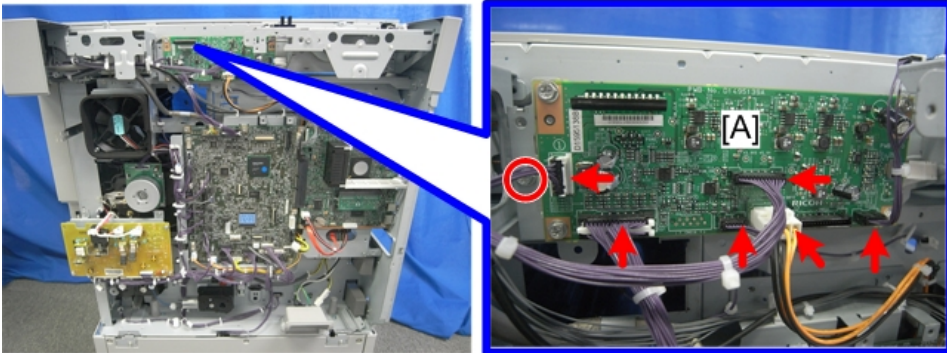

d1582099

Exposure Lamp

1. Exposure glass (🔩 p.166 "Exposure Glass/DF Exposure Glass (CCD)")

2. Move the exposure lamp [A] to the point shown below.

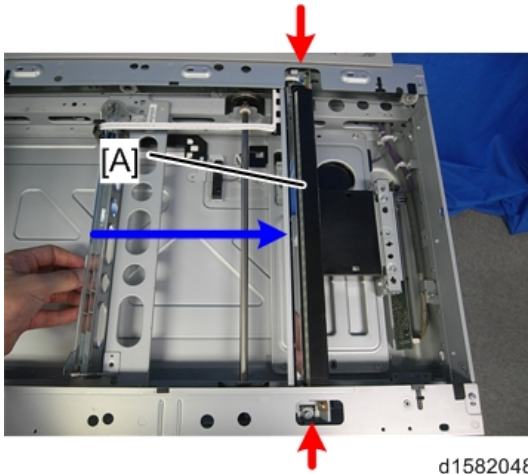

3. Exposure lamp [A] (⚙️ x 2, FFC x 1)

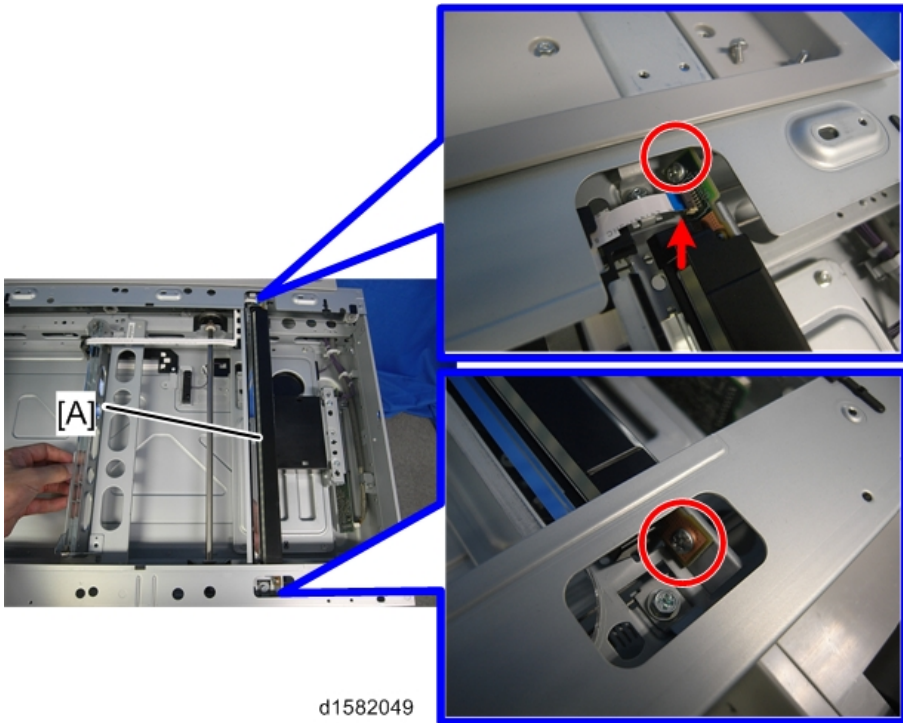

APS Sensor (Length)

1. Exposure glass (🔗 p.166 "Exposure Glass/DF Exposure Glass (CCD)")

2. APS Sensor (length) [A] (🔧 x 1, Hook x 2)

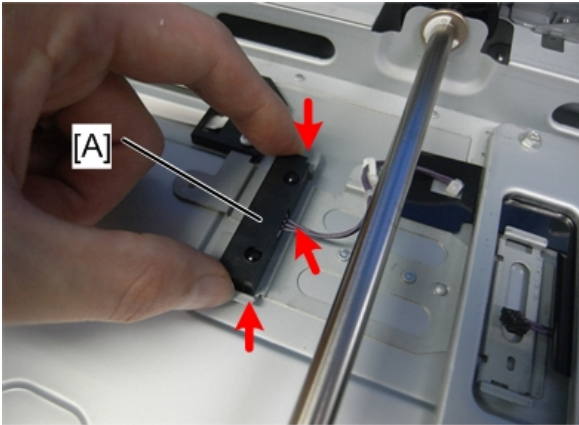

d1582050

4

Scanner Motor

1. Rear cover (🔧 p.152)
2. DF exposure glass (🔧 p.166 "Exposure Glass/DF Exposure Glass (CCD)")
3. Top covers (🔧 p.153 "Upper Covers (D158/D159)")
4. SIO board (with bracket [A]), and scanner motor harness [B] (🔧 x 1, 📏 x 1) (🔧 p.169).

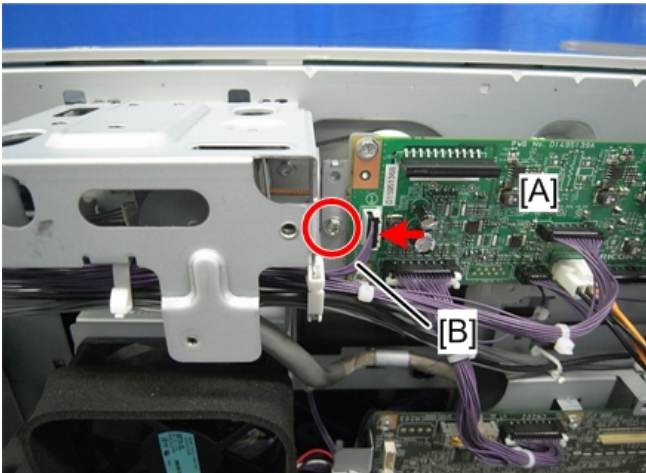

d1582051

5. Rear bracket [A] (⚙️ x 5)

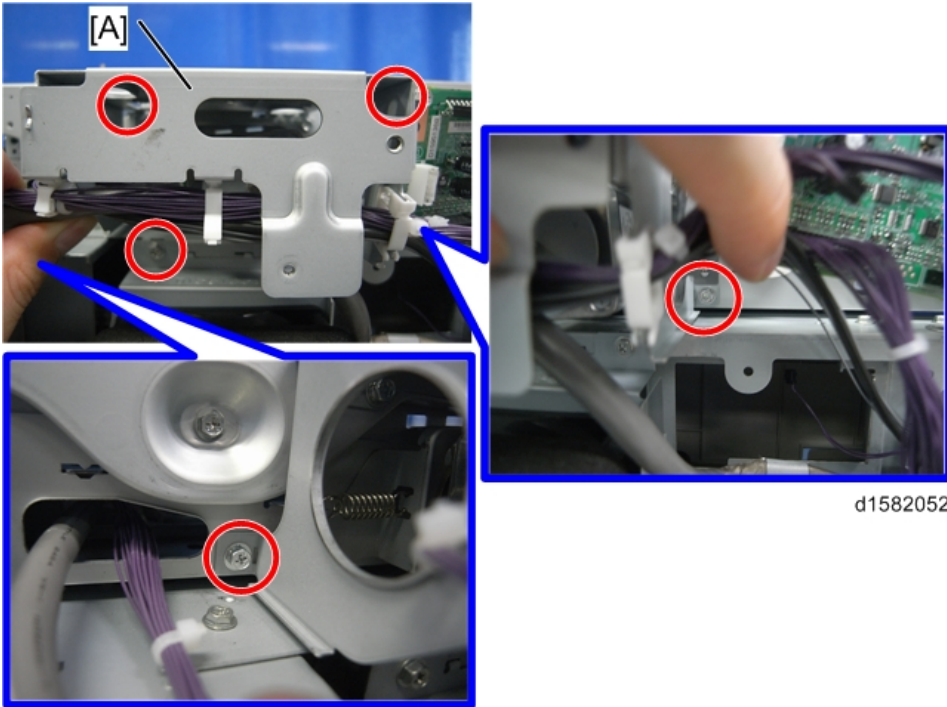

d1582052

6. Motor bracket [A] (⚙️ x 2, 📏 x 1, Spring x 1)

⬇️ Note

- When you reassemble, install the belt [B] first, and then set the spring. Fasten screw [C], then fasten screw [D].

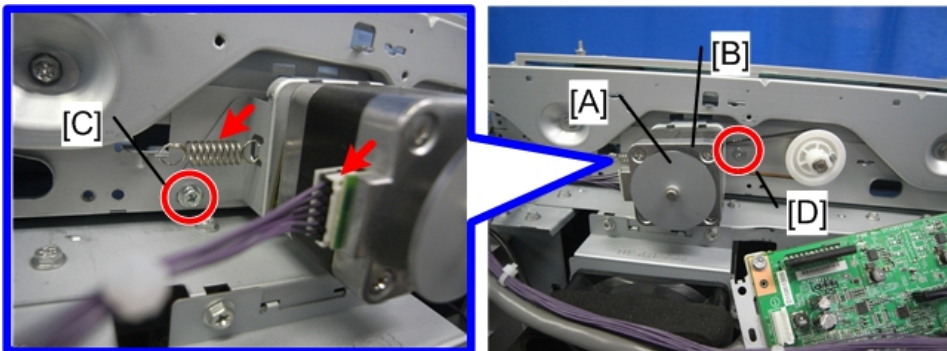

d1582053

7. Scanner motor [A] (⚙️ x 2, Belt x 1)

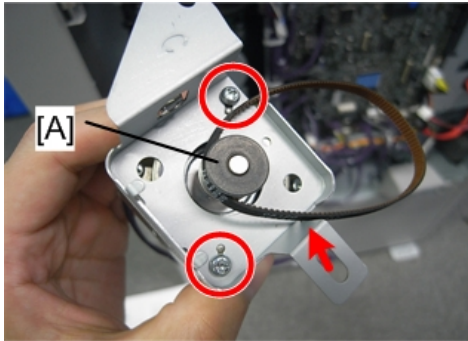

d1582054

↓ Note

- Adjust the image quality after you install the motor.

4

Scanner Home Position Sensor

1. DF exposure glass (📄 p.166 "Exposure Glass/DF Exposure Glass (CCD)")
2. Top rear cover (📄 p.153 "Upper Covers (D158/D159)")
3. DF exposure glass guide (📄 p.166)
4. Sensor tape [A].
5. Scanner home position sensor [B] (📄 x 1, Hook x 3).

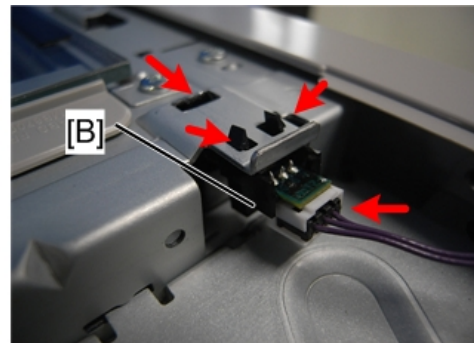

d1582057

Front Scanner Wire

1. Exposure glass/DF exposure glass (📄 p.166 "Exposure Glass/DF Exposure Glass (CCD)")

2. Scanner left stay [A] (⚙️ x 12)

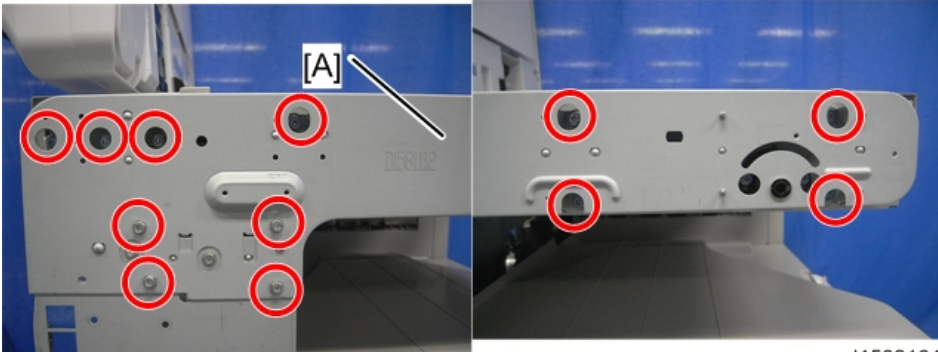

d1582164

4

3. Scanner left rail frame [A] (⚙️ x 3)

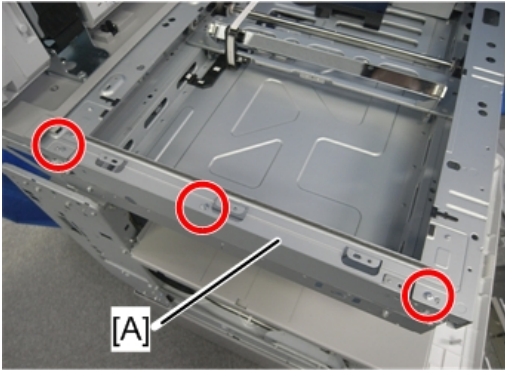

d1582165

4. Scanner front stay [A] (⌀ x 5)

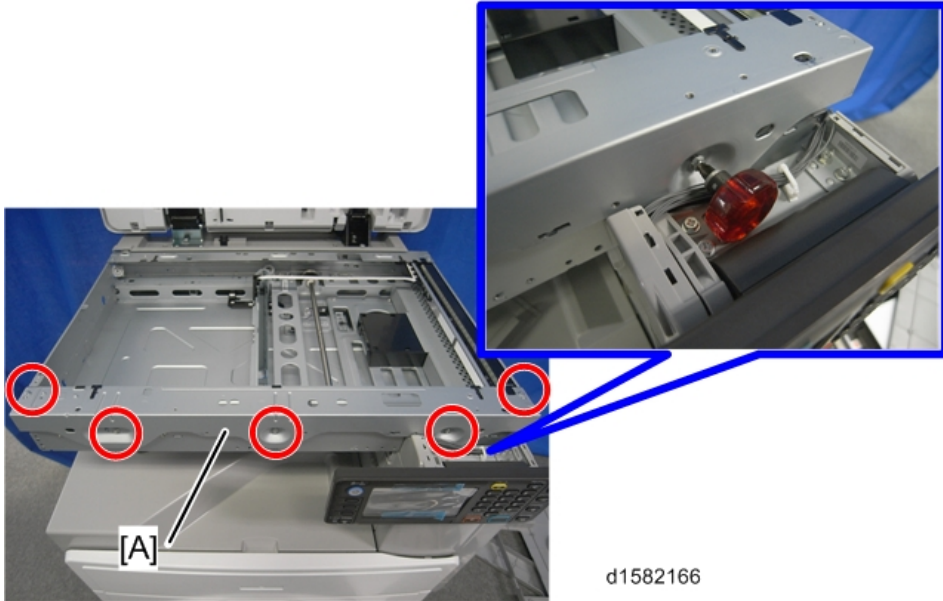

↓ Note

- If you have difficulty to remove the scanner front stay, remove the operation panel using a short 'stubby' screwdriver.

5. To make reassembly easy, slide the 1st scanner carriage to the right.

6. Front scanner wire brackets [A] , [B] (⌀ x 2)



d1582167

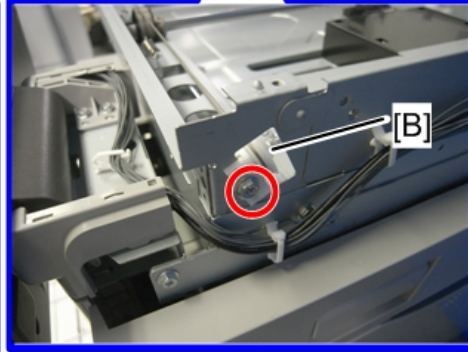
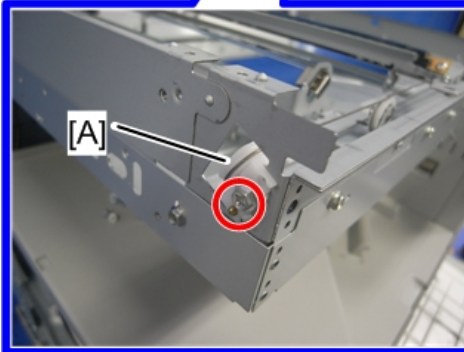

7. Front scanner wire and scanner drive pulley [A] (⌀ x 2, Scanner Clamp x1)

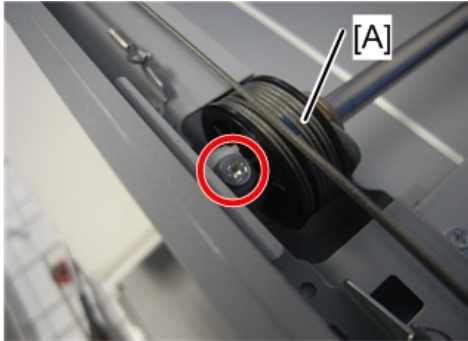

d1582208

Reassembling the Front Scanner Wire

1. Pass the wire with a ball [A] through the scanner drive pulley as shown below.

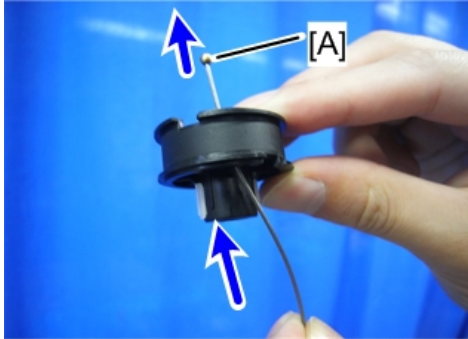

d1582220

2. Position the center ball [A] in the middle of the forked holder.

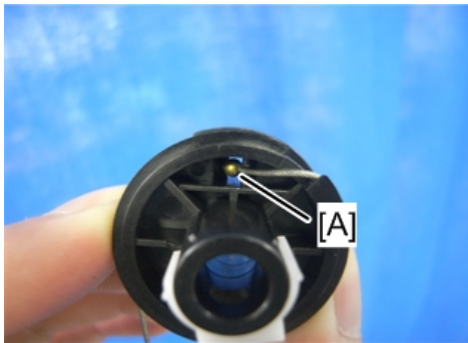

d1582221

3. Wind the right end counterclockwise (shown from the machine's front) five times. Wind the left end clockwise twice.

Note

- The two blue marks [A] come together when you have done this. Stick the wire to the pulley with tape. This lets you easily handle the assembly at the time of installation.

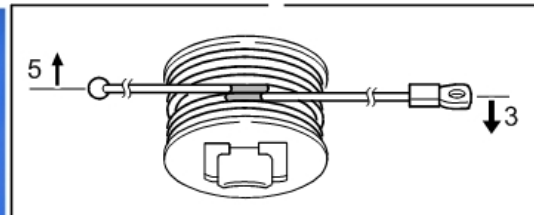
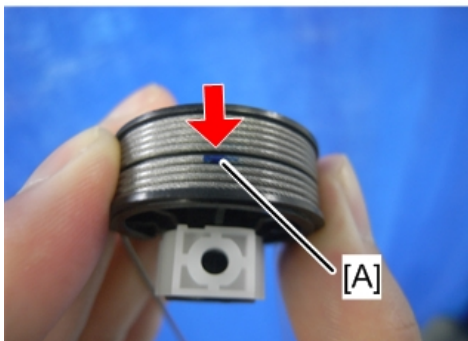

d1582222

4. Stick the wire to the pulley with tape, so you can easily handle the pulley and wire during installation.
5. Attach the scanner drive pulley [A] to the shaft and hook the wire onto the left pulley.

Note

- Do not attach the pulley to the shaft with the screw at this time.

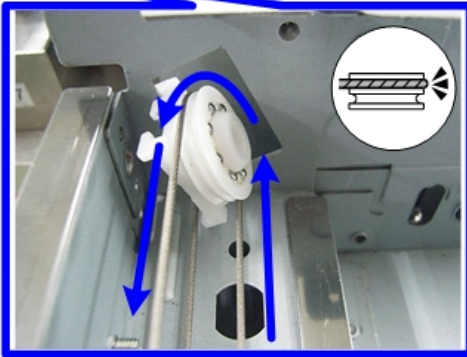
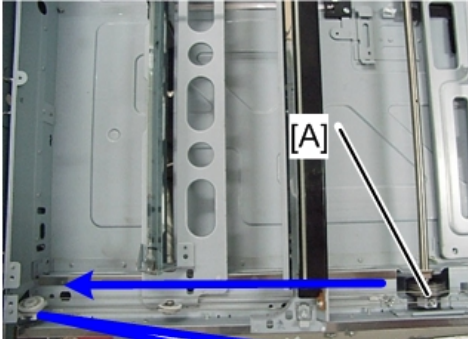

d1582221

6. Hook the wire [A] onto the 2nd scanner unit as shown below.

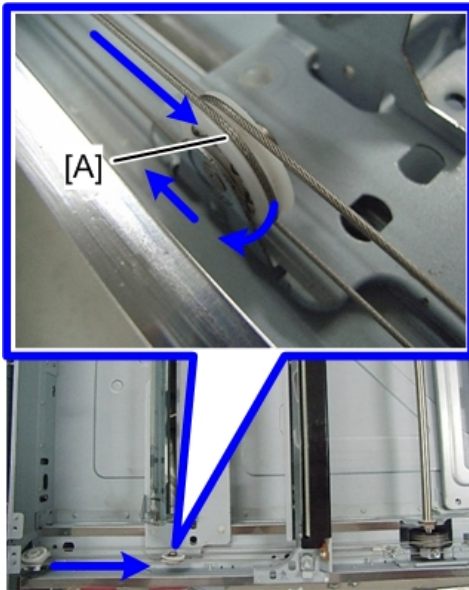

d1582224

7. Insert the left end [A] into the slit.

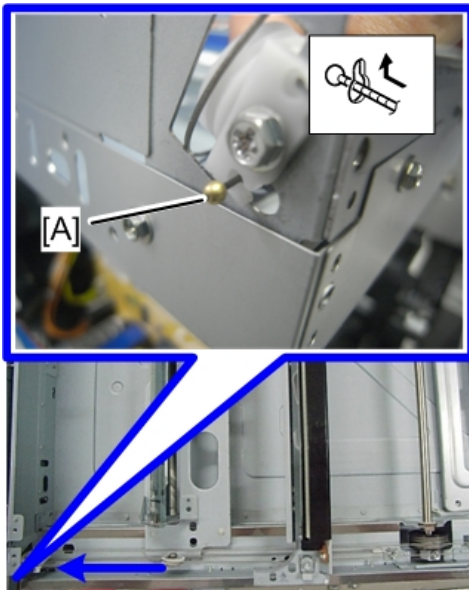

d1582225

8. Hook the wire onto the right pulley [A].

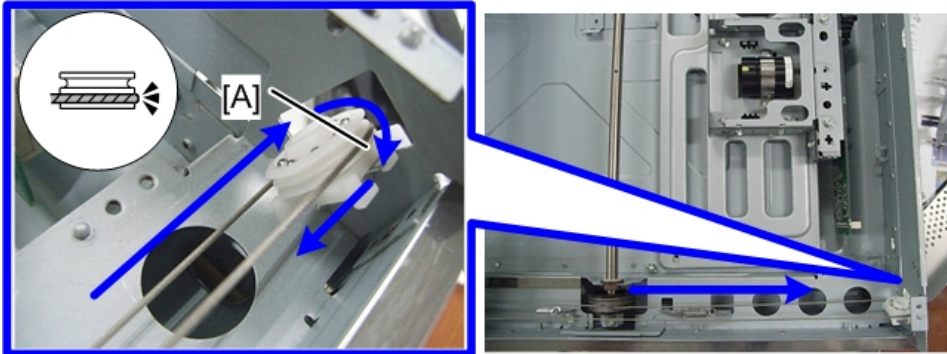

d1582226

4

9. Hook the wire [A] onto the 2nd scanner unit as shown below.

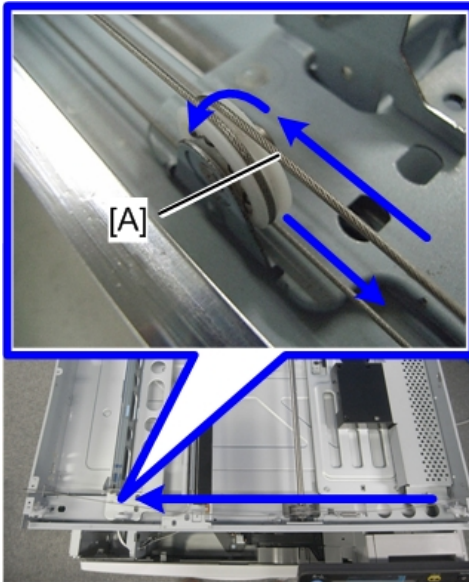

d1582227

10. Hook the right end onto the front scanner wire bracket [A].

Note

- Do not secure the scanner wire bracket with the screw at this time (before step 12).

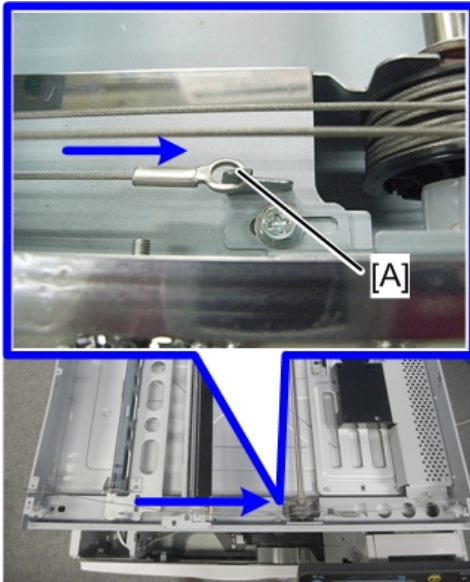

d1582228

11. Remove the tape from the drive pulley.
12. Adjust the scanner positions (☛ p.186).

⬇ Note

- After replacing the scanner wire, do the image adjustments in the following section of the manual (☛ p.258 "Copy Adjustments Printing/Scanning").

Rear Scanner Wire

1. Exposure glass/DF exposure glass (☛ p.166 "Exposure Glass/DF Exposure Glass (CCD)")
2. Scanner left stay (☛ p.173 "Front Scanner Wire")
3. Scanner left rail frame (☛ p.173 "Front Scanner Wire")
4. SIO with bracket (☛ p.169)

5. Left rear bracket [A] (⚙️ x 4, 📏 x 1)

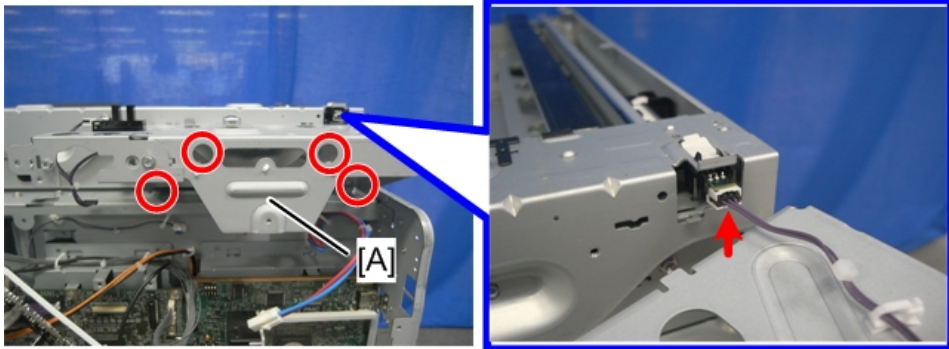

d1582169

4

6. Right rear bracket [B] (⚙️ x 4)

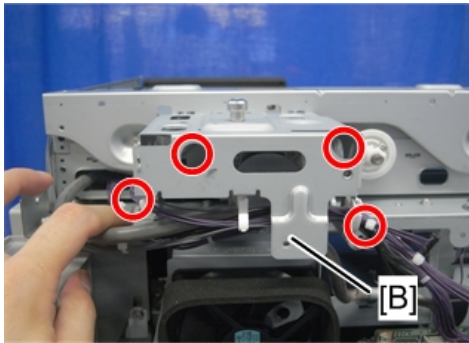

d1582204

7. Rear rail frame [A] (⚙️ x 5)

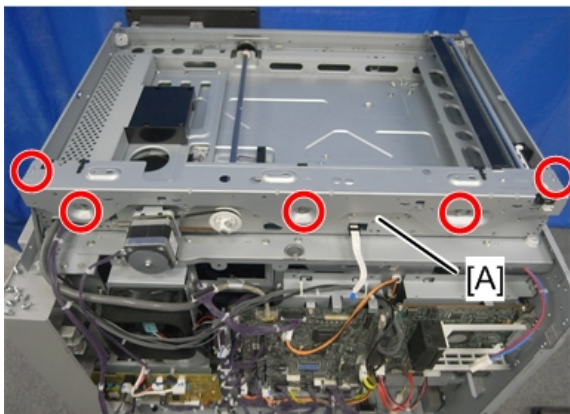

d1582170

8. To make reassembly easy, slide the first scanner [A] to the position shown below.

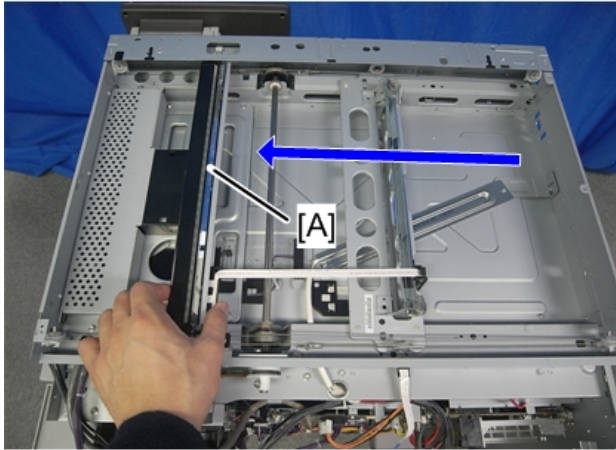

d1582205

9. Rear scanner wire brackets [A], [B] (⌀ x 2)

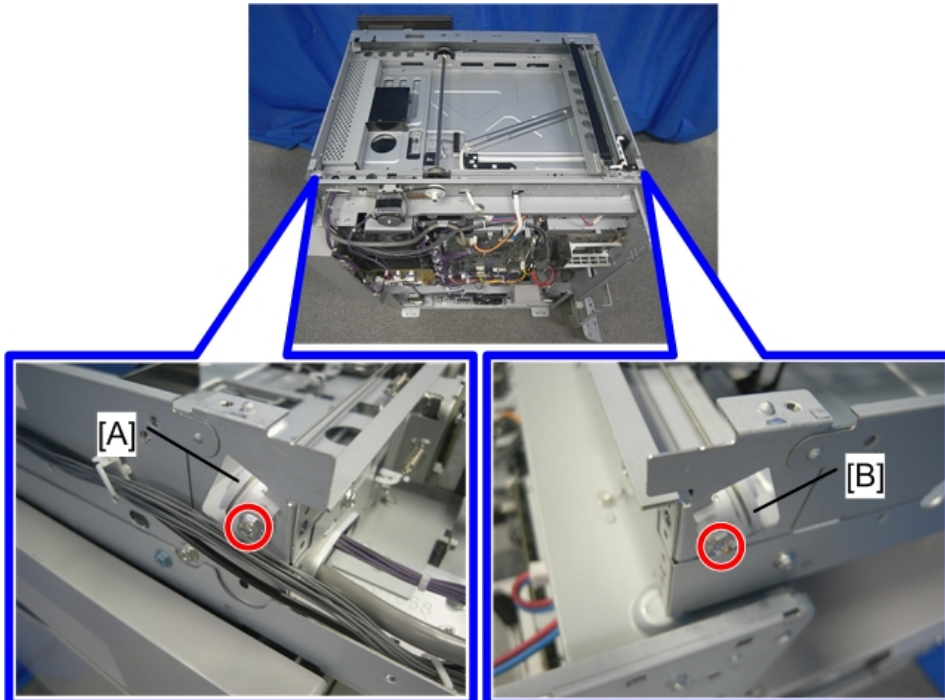

d1582171

10. Scanner motor gear [A] (⚙️ x 1)

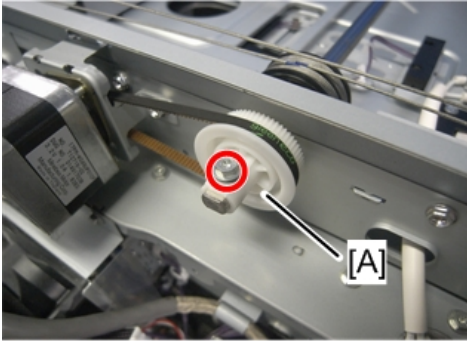

d1582206

4

11. Rear scanner wire and scanner drive pulley [A] (⚙️ x 2)

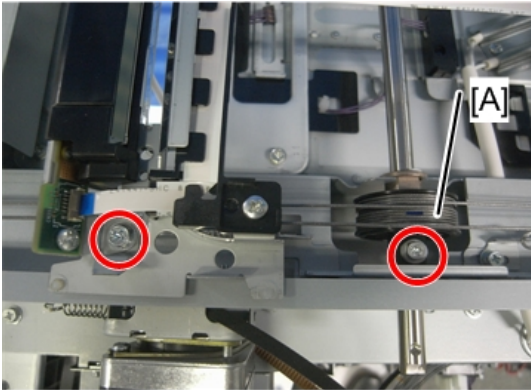

d1582207

Reassembling the Rear Scanner Wire

1. Pass the wire end with a ball (A) through the scanner drive pulley as shown below.

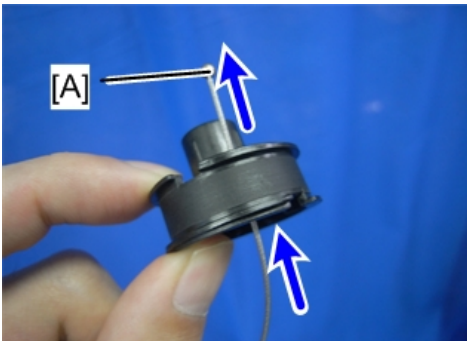

d1582229

- Position the center ball [A] in the middle of the forked holder.

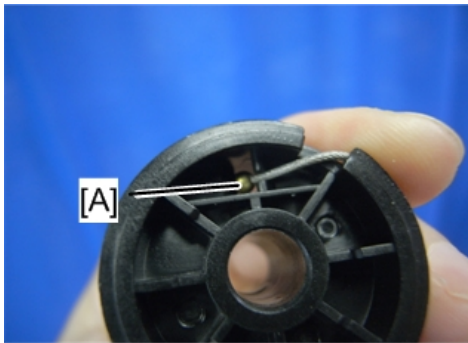

d1582230

- Wind the end with the ring clockwise (shown from the machine's front) three times; wind the ball end clockwise (shown from the machine's front) five times.

Note

- The two blue marks [A] should meet when you have done this.

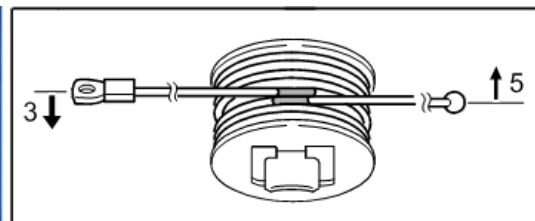
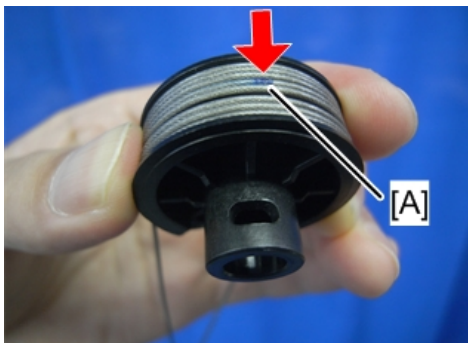

d1582231

- Stick the wire to the pulley with tape, so you can easily handle the pulley and wire during installation.
- Install the drive pulley on the shaft.

Note

- Do not secure the scanner wire bracket with the screw at this time (before step 7).

- Install the wire.

Note

- The winding of the wire on the three pulleys at the rear of the scanner should be the same as the winding on the three pulleys at the front. This must show as a mirror image. Example: At the front of the machine, the side of the drive pulley with the three windings must face the front of the machine. At the rear of the machine, it must face the rear.

7. Adjust the scanner position (☛ p.186).

↓ Note

- After replacing the scanner wire, do the image adjustments in the following section of the manual (☛ p.258 "Copy Adjustments Printing/Scanning").

Adjusting the Scanner Positions

1. Insert a scanner-positioning pin through the 2nd carriage holes [A] and [D].
2. Insert another scanner positioning pin through the 1st carriage hole [B] and [C].

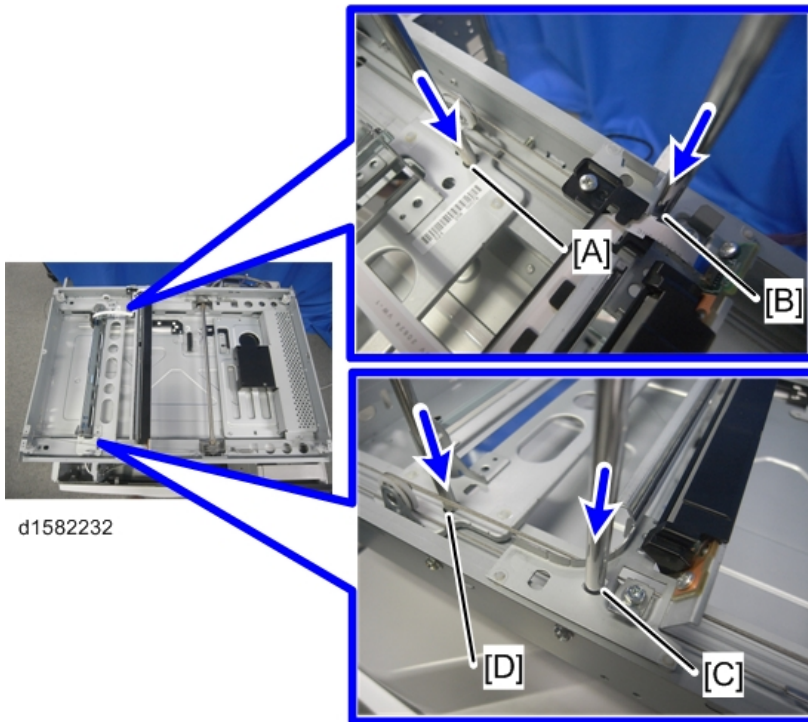

3. Screw the drive pulley to the shaft [A].
4. Screw the scanner wire bracket to the front rail [B].

5. Install the scanner wire clamp [C].

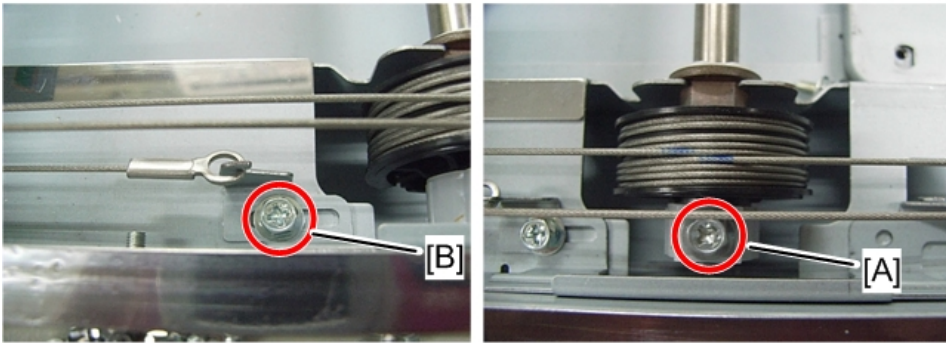
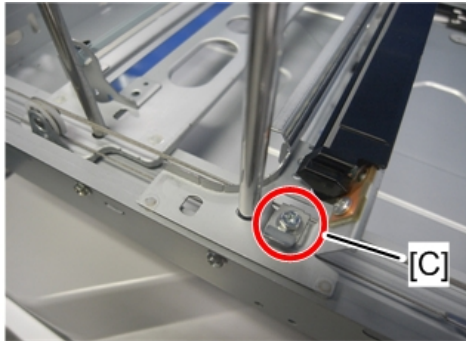

d1582233

6. Fasten the rear scanner wire using screws in the same manner as you have done for the front scanner wire.
7. Pull out the positioning pins.
8. Reassemble the machine and check the operation.

Note

- Make sure the 1st and 2nd carriages move smoothly after you remove the positioning pins.
- After replacing the scanner wire, do the image adjustments in the following section of the manual (p.258 "Copy Adjustments Printing/Scanning").

Scanner Unit (D160/D161/D170)

★ Important

- Unplug the machine power cord before starting the following procedures.
- Do not touch the guide rods [A], because they are greased.

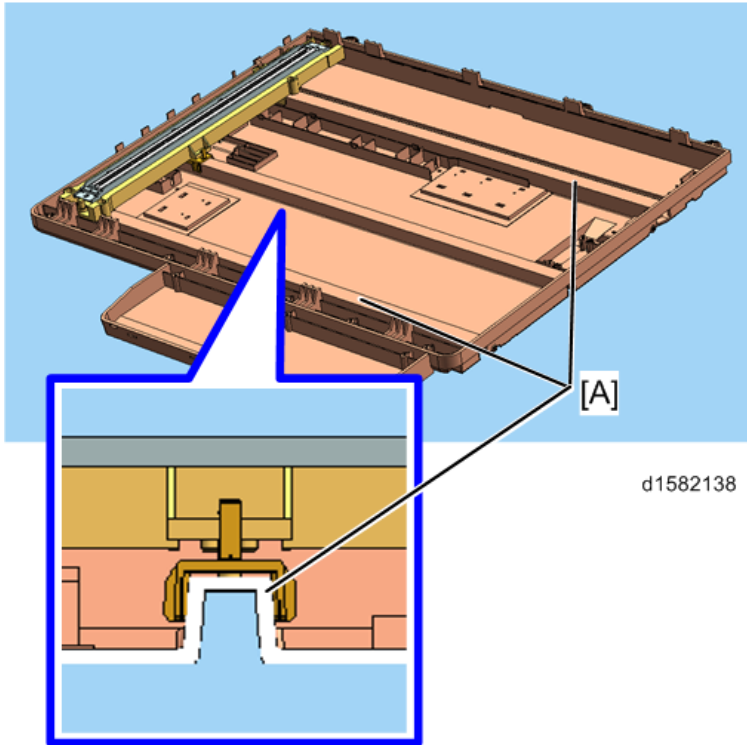

↓ Note

- CCD Scanner – D158/D159
- CIS Scanner – D160/D161/D170

When reassembling

- Adjust the following SP modes after you replace the scanner unit or each part of the scanner unit:
- SP4-008-001 (Sub Scan Magnification Adj): (☛ p.258 "Copy Adjustments Printing/Scanning")
- SP4-009-001 (Main Scan Magnification Adj): (☛ p.258 "Copy Adjustments Printing/Scanning")
- SP4-010-001 (Sub Scan Registration Adj): (☛ p.258 "Copy Adjustments Printing/Scanning")
- SP4-011-001 (Main Scan Reg): (☛ p.258 "Copy Adjustments Printing/Scanning")
- SP4-688-001 (DF: Density Adjustment): Use this to adjust the density level if the image density of outputs made in the DF and Platen mode is different.

Scanner Unit

1. Operation panel and top covers (☛ p.155 "Upper Covers (D160/D161/D170)", ☛ p.157 "Operation Panel (D160/D161/D170)")
2. Four brackets [A]
 - Left side (🔩 x 4)

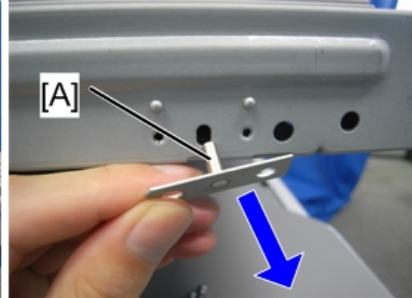
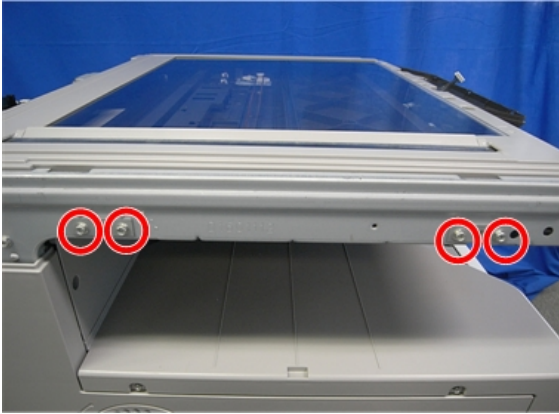

d1582063

- Right side (🔩 x 4)

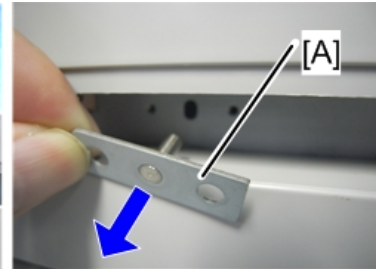

d1582209

3. Scanner unit

- 🔩 x 1

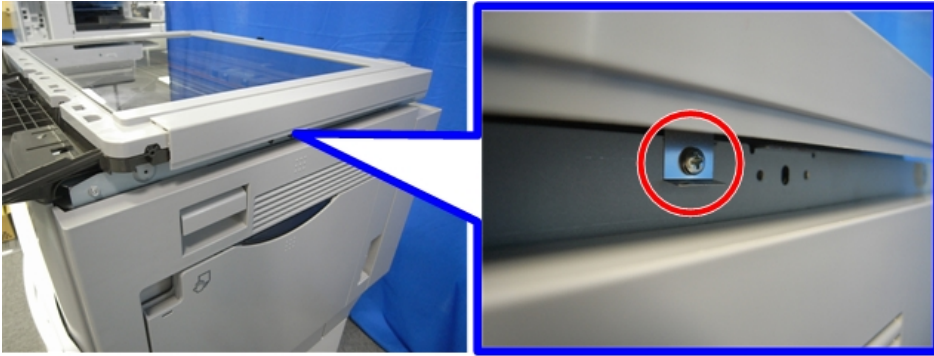

d1582064

4

- FFC [A] x 1,  x 3

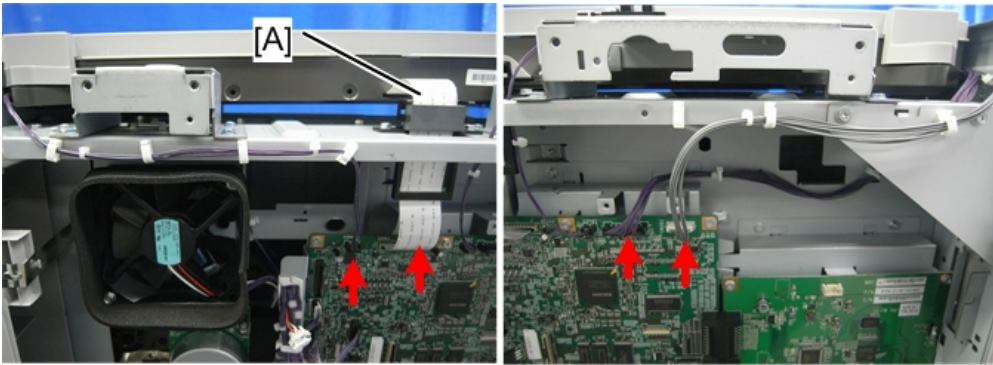

d1582210

-  x 8

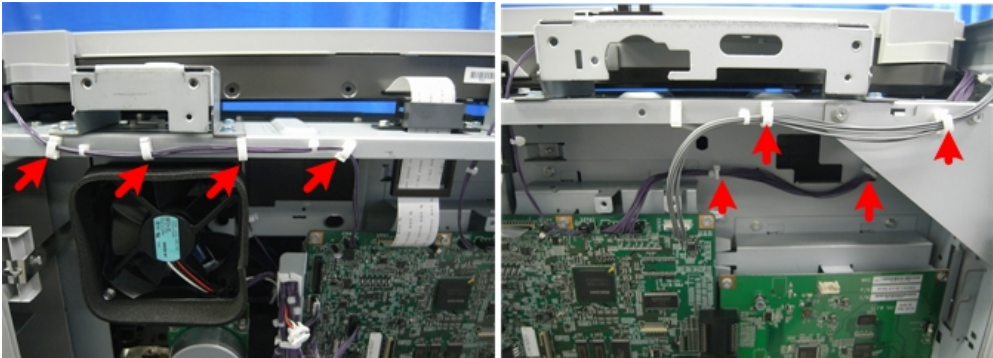

d1582211

- Scanner unit [A]

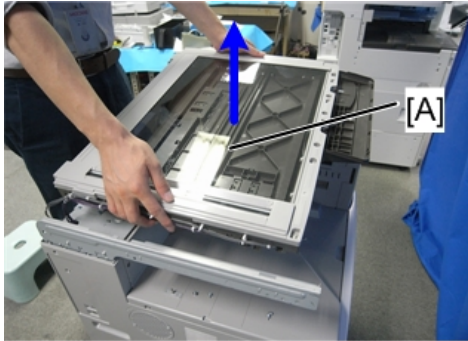

d1582065

APS Sensors (Width/Length)

4

1. Rear cover (● p.152)
2. Platen cover, or ARDF (if installed)
3. Top covers (● p.155 "Upper Covers (D160/D161/D170)")
4. Exposure glass/DF exposure glass (● p.195 "Exposure Glass/DF Exposure Glass (CIS)")
5. Sensor cover [A] for length (Hook x 4)

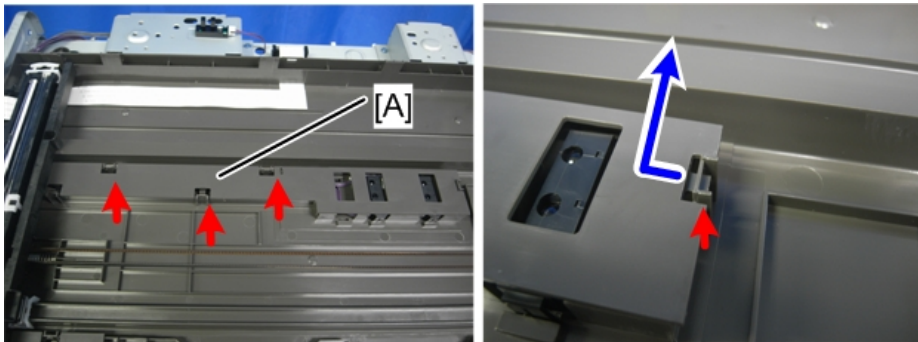

d1582114

6. Sensor cover [A] for width (Hook x 3)

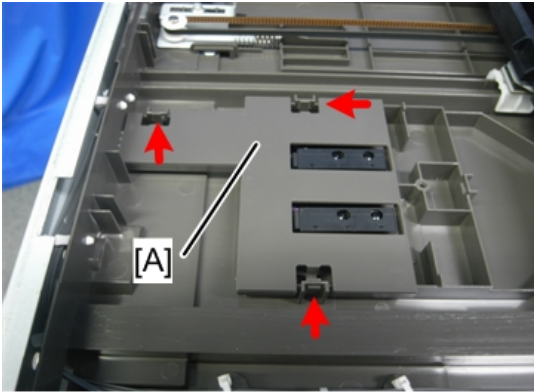

d1582115

4

7. APS sensor (width) [A] (☒ x 2)

8. APS sensor (length) [B] (☒ x 2)

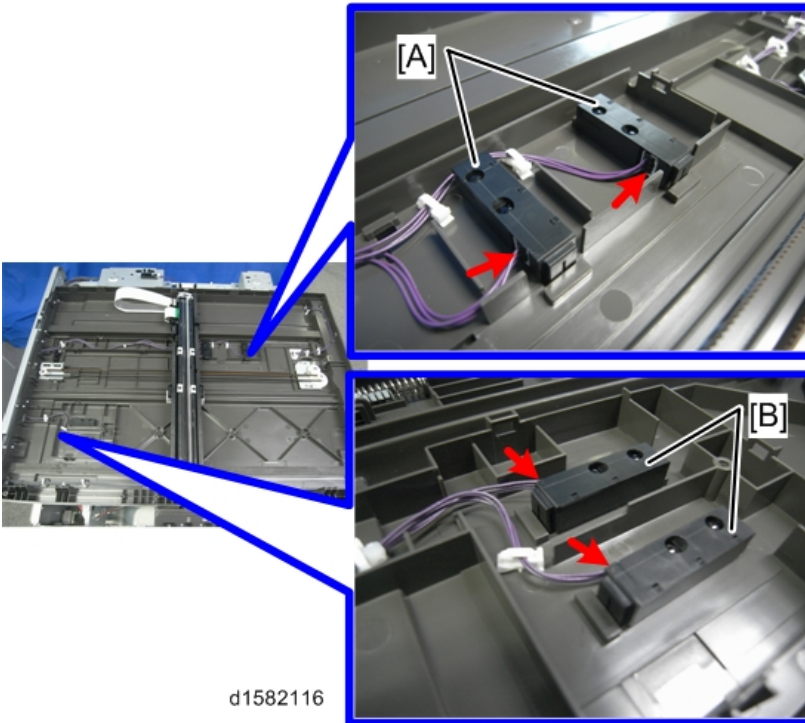

d1582116

↓ Note

- The sensor location depends on the country of use.

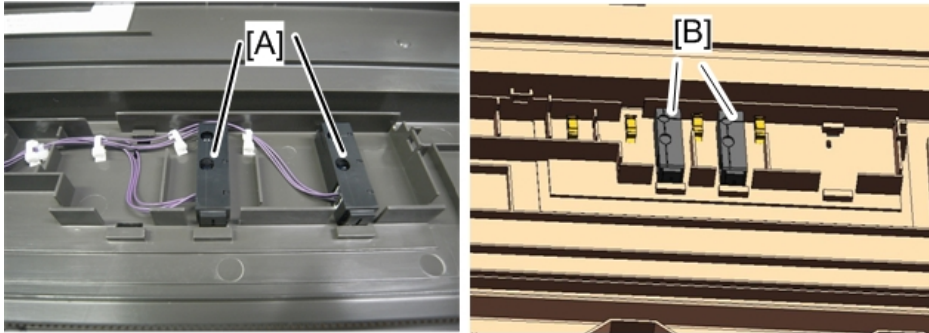

d1582117

- [A]: All areas except China
- [B]: China only

4

CIS Unit and Scanner Drive Belt

★ Important

- When replacing the CIS unit or scanner drive belt, be careful not to touch the grease that is applied to the base of the scanner under the timing belt.
1. Rear cover (☛ p.152)
 2. Platen cover, or ARDF (if installed)
 3. Top covers (☛ p.155 "Upper Covers (D160/D161/D170)")
 4. Exposure glass/DF exposure glass (☛ p.195 "Exposure Glass/DF Exposure Glass (CIS)")

5. CIS unit [A] (FFC x1, Hook x 1)

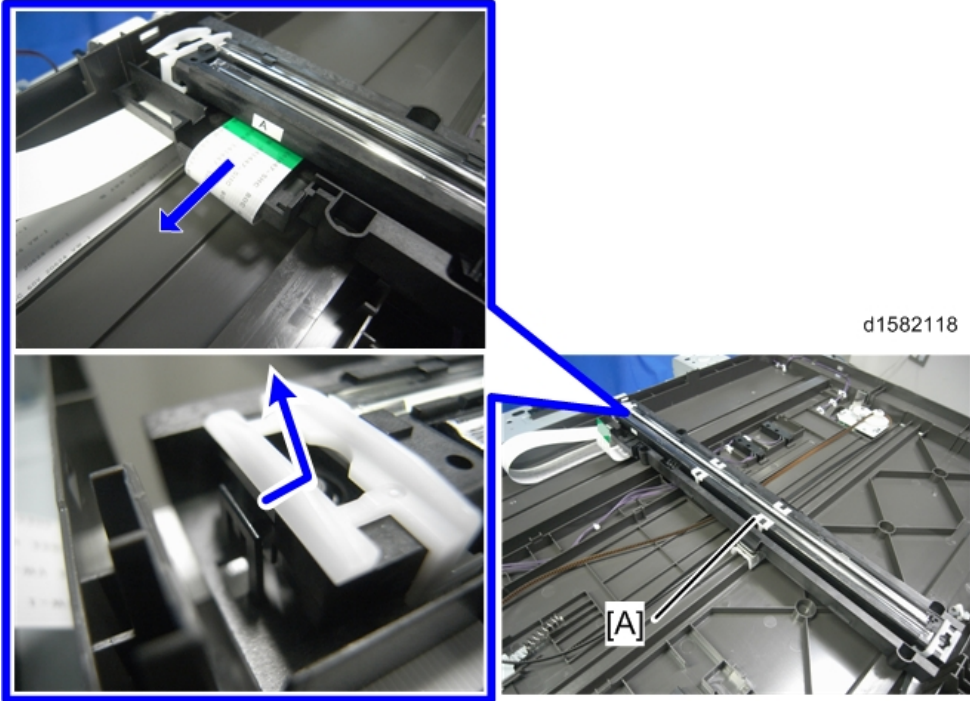

4

6. Left bracket [A] (⌀ x 1)



7. Scanner drive belt [A]

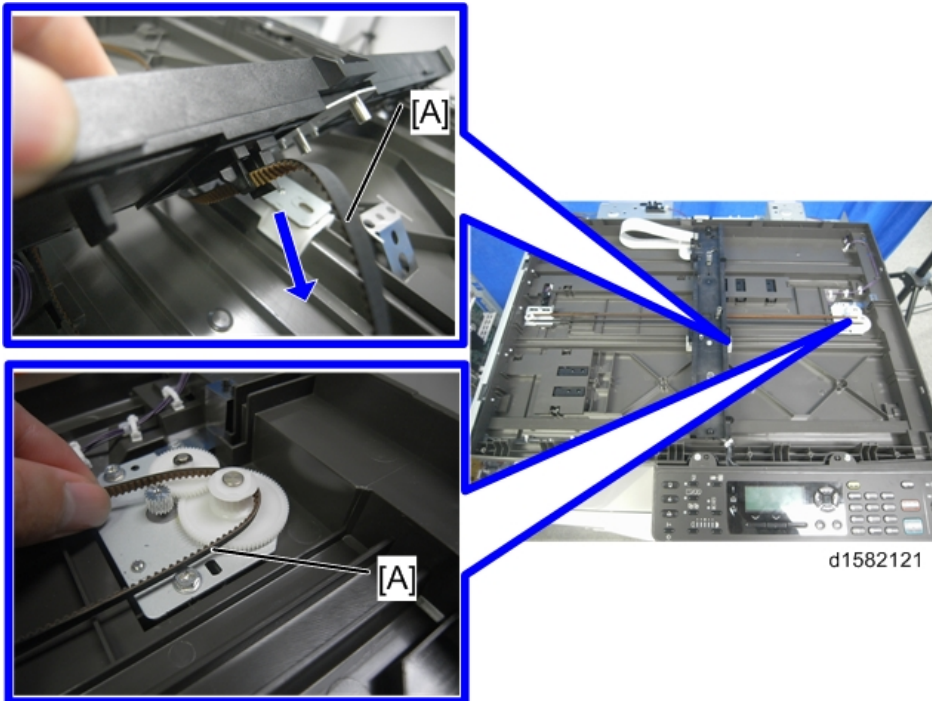

4

Exposure Glass/DF Exposure Glass (CIS)

1. Rear cover (☛ p.152)
2. Platen cover, or ARDF (if installed)
3. Top covers (☛ p.155 "Upper Covers (D160/D161/D170)")
4. Exposure glass/DF exposure glass [A] (☛ x 8, Hook x 3)



d1582110

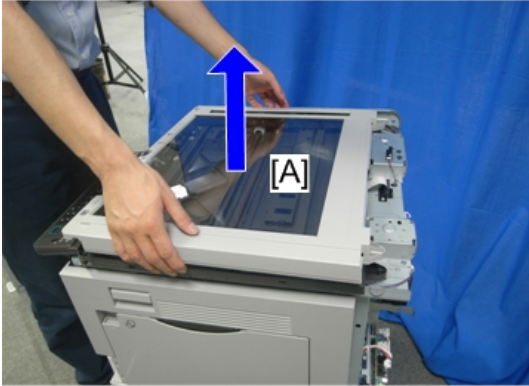

d1582111

4

Note

- Exposure glass [A], DF exposure glass [B] and cover [C] are all in one unit. Do not disassemble into the individual parts.

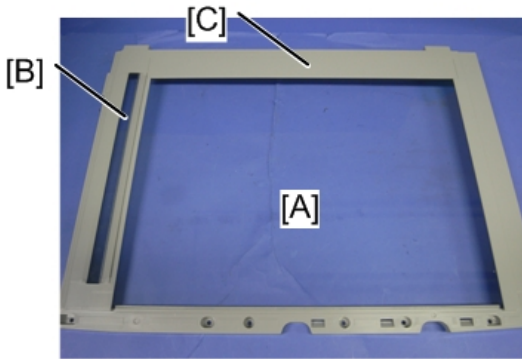

d1582112

Laser Unit

⚠ WARNING

- The laser beam can seriously damage your eyes. Be absolutely sure that the main power switch is off and that the machine is unplugged before you access the laser unit.

★ Important

- Unplug the machine power cord before starting the following procedures.

Location of Caution Decal

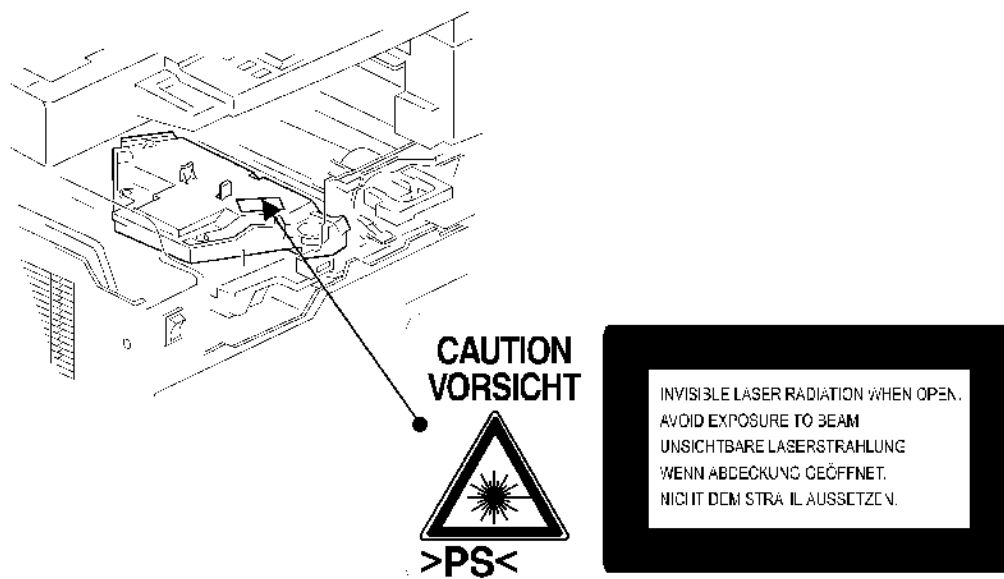

Toner Shield Glass

1. Remove the toner bottle.
2. Output tray, exit cover, exit rear cover (☛ p.152)
3. Front cover (☛ p.159)

4. Toner shield glass [A]



d1582066

4

Laser Unit

1. Toner shield glass (☛ p.197)
2. Laser unit [A] (🔧 x 3, 📦 x 2)

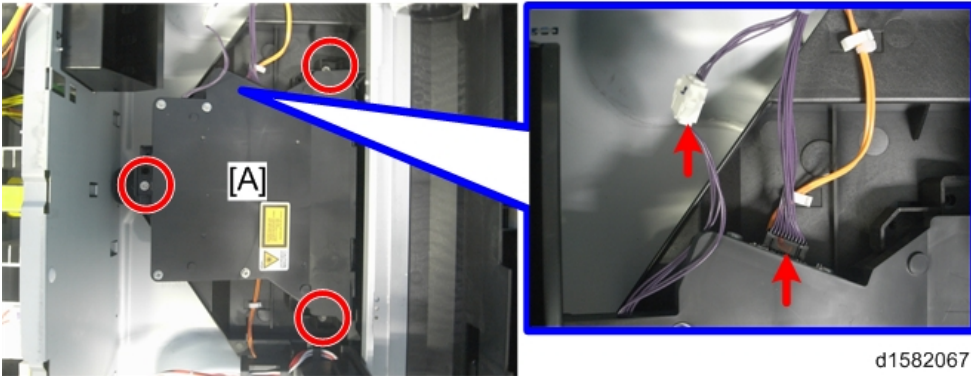

d1582067

Polygonal Mirror Motor

1. Laser unit (☛ p.198)

2. Laser unit cover [A] (⚙️ x 4)

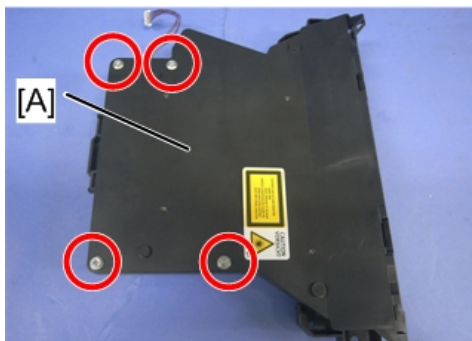

d1582068

3. Polygonal mirror motor [A] (⚙️ x 4, 📏 x 1)

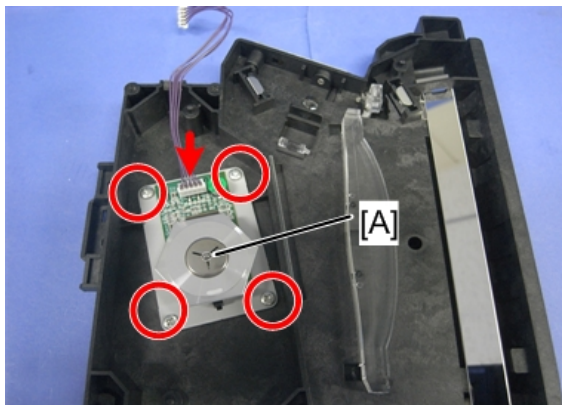

d1582070

4. After reassembling, adjust the image quality (🔧 p.258).

PCU Section

★ Important

- Unplug the machine power cord before starting the following procedures.

PCU

1. Toner bottle with the holder [A]

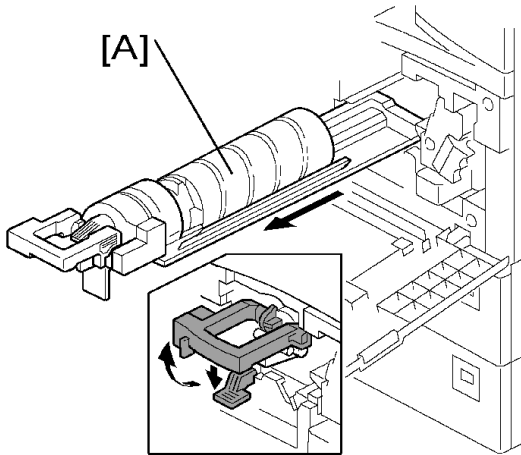

2. Open the right door.
3. Press the latch [B] and pull out the PCU [C].

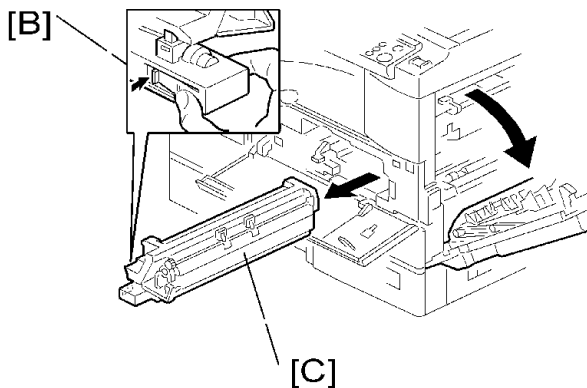

↓ Note

- Do not touch the OPC drum surface with bare hands.

4. Load new developer (👉 p.204).

5. Do SP2-801-001 (Developer Initialization) to reinitialize the TD sensor when you reassemble.

Pick-off Pawls and Toner Density Sensor

⚠ CAUTION

- Do not turn the PCU upside down. This causes toner and developer to spill out.

1. PCU (☛ p.200)
2. Pawl [A]

⬇ Note

- Pull down the pawl and release the bottom end.

3. Toner density sensor [B] (🔩 x 1)

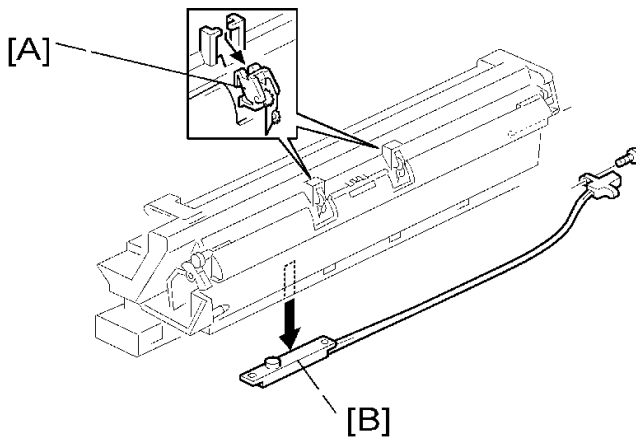

⬇ Note

- The toner density sensor is taped to the bottom of the PCU. Pry it off with a regular screwdriver

4. After reinstalling the pick-off pawls or toner density sensor, adjust the image quality (☛ p.205 "After Replacement or Adjustment").

OPC Drum

1. PCU (☛ p.200)
2. Front side piece [A] (🔩 x 1)
3. Rear side piece [B] (🔩 x 2, 1 coupling)

4. Separate the drum section [C] from the developer section [D].

↓ Note

- To ensure that the left-side gears line up, keep the drum cover [E] closed when reinserting the front side piece.

5. Pry out the drum retaining clip [F].

↓ Note

- Install the clip in the same orientation (with the lip facing away from the drum shaft) when you reassemble.

6. OPC drum [G]

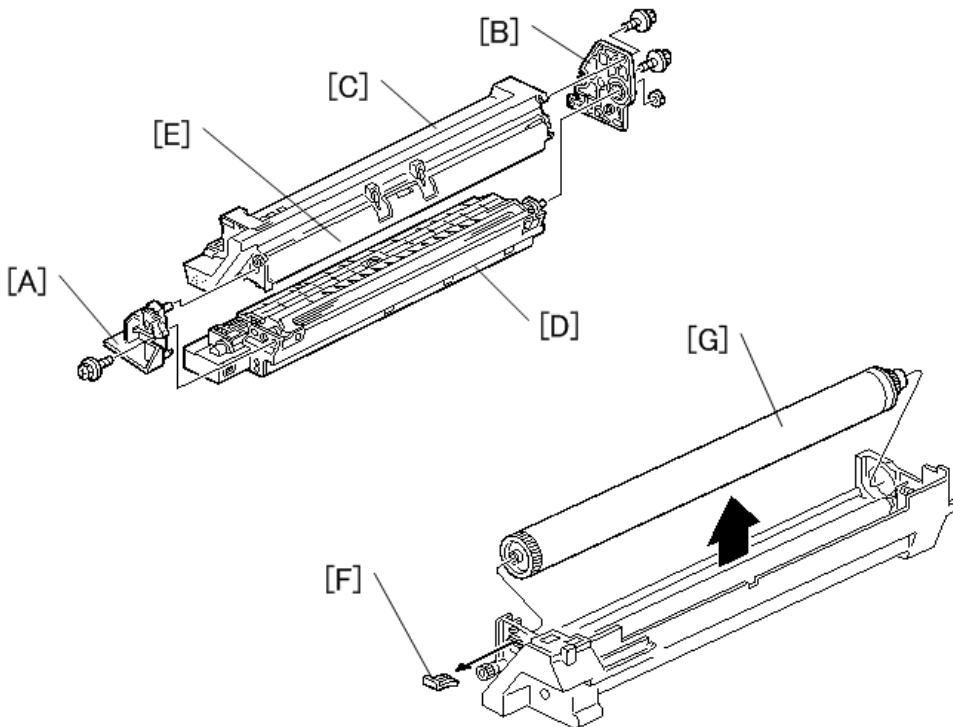

7. When reassembling, adjust the image quality (☛ p.205 "After Replacement or Adjustment").

Charge Roller and Cleaning Brush

1. OPC Drum (☛ p.201)
2. Holding pin [A]
3. Stepped screw [B]

4. Charge roller [C] and cleaning brush [D] (with the holders and springs)

↓ Note

- Turn the gear [E] (as necessary) so that the rear holder [F] comes out.

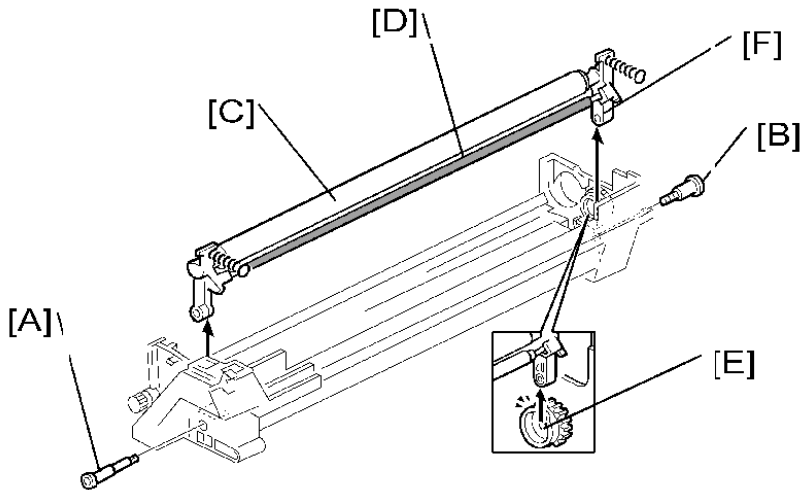

5. When reassembling, adjust the image quality (☛ p.205 "After Replacement or Adjustment").

Cleaning Blade

1. Drum charge roller (☛ p.202 "Charge Roller and Cleaning Brush")
2. Cleaning blade [B] (🔩 x 2)
3. When reassembling, adjust the image quality (☛ p.205 "After Replacement or Adjustment").

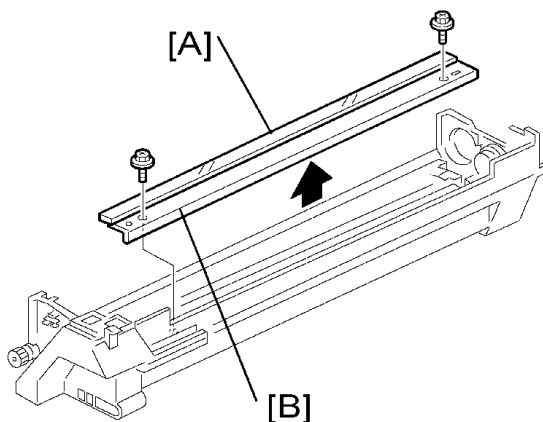

★ Important

- Reassembling
- Apply toner to the edge of the new cleaning blade when you replace the cleaning blade. This prevents possible damage to the OPC drum and blade.
 1. After installing the cleaning blade, remove some of the toner from the old blade with your finger.
 2. Apply the toner to the edge [A] of the new cleaning blade. Make sure to apply the toner evenly along full length of the new cleaning blade.

Developer

4

1. PCU (🔧 p.200)
2. To let the toner fall to the development section, gently tap about eight different spots on the top of the PCU with a screwdriver. Each spot must be approximately at an equal distance from the next spot.
3. Reinstall the PCU in the copier.
4. Turn the main switch on.
5. Open and close the front door and wait for the machine to rotate the development roller for about 10 seconds.
6. Repeat the previous step two more times.
7. PCU (🔧 p.200)
8. Separate the developer section from the OPC drum section (🔧 p.201).
9. Top part [A] of the development unit (🔧 x 5)

↓ Note

- Release the hook [B].
10. Set the coupling [C] back to the shaft.
 11. Turn the coupling in the direction of the arrow [D] to remove developer from the roller.

12. Turn the bottom part [E] over and rotate the gears to remove the developer.

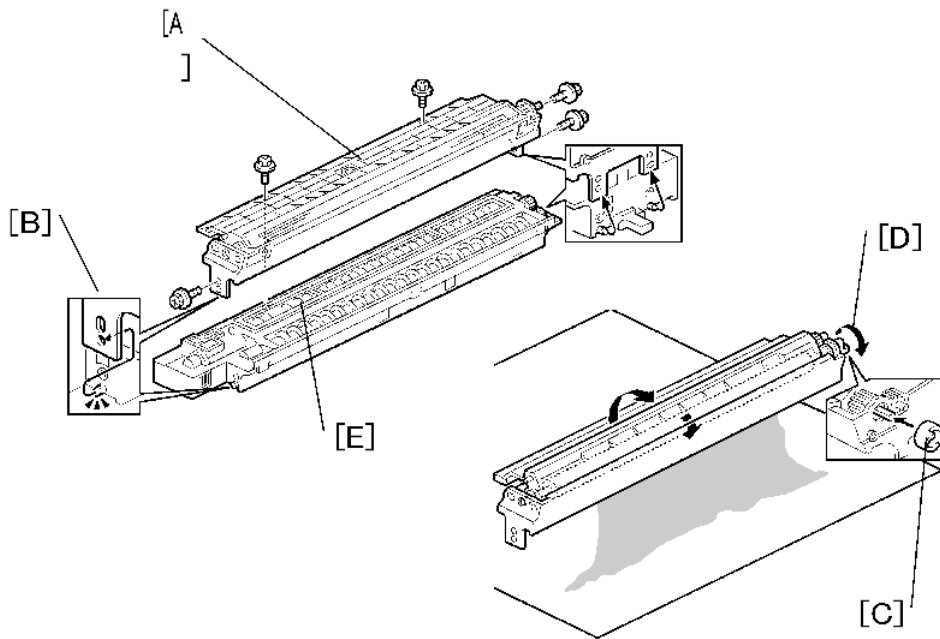

13. Load new developer.

14. When reassembling, execute SP2-801-001 (Developer Initialization) to reinitialize the TD sensor.

Note

- Make sure no toner or developer stays on the gear. Clean the gears as necessary with a blower brush, etc.
- Be sure to replace the Mylar at the rear side in the correct position. (The Mylar protects the gears at the rear side from falling toner).

After Replacement or Adjustment

Important

- Do the following procedure after replace or adjust any of the PCU components. This procedure is not necessary when you replaced the whole PCU with a new one.

1. Take 5 sample copies.
2. If black dots (dropped toner) show on any of the copies, continue as follows. (If all copies are clean, you don't need to do the following steps.)
3. Remove the PCU from the mainframe.

4. Tap the top of the PCU with a screwdriver at eight evenly spaced locations (two or three taps at each spot), to knock the recycled toner down into the development section.
5. Put the PCU back into the mainframe.
6. Turn the main power on. Then open and close the door and wait for the machine to rotate the development roller for 10 seconds. Then open and close the door two more times, so that total rotation time is 30 seconds.
7. Make some sky-shot copies (or solid black prints).
 - If using A4 or 8¹/₂" x 11" paper, make 4 copies/prints.
 - If using A3 or 11" x 17" paper, make 2 copies/prints.
 - To make solid black prints, use SP5-902-001 pattern 8 (for D160/D161/D170) or SP2-109-001 pattern 20 (for D158/D159).

 **Note**

- Step 7 is required only after parts replacement or adjustment. You do not need to make sky-shot (or solid black) copies after you replace the developer.

Toner Supply Motor

★ Important

- Unplug the machine power cord before starting the following procedure.
1. Output tray (☛ p.152 "Output Tray, Exit Cover, Exit Rear Cover")
 2. Open the front door.
 3. Toner bottle holder (☛ p.200 "PCU")
 4. Toner supply motor [A] (☛ x 1)

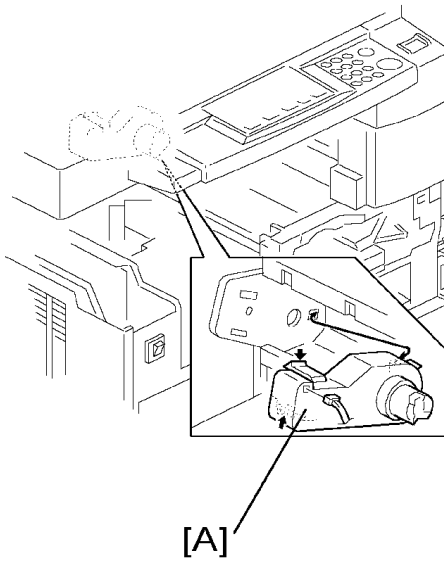

Paper Feed Section

★ Important

- Unplug the machine power cord before starting the following procedures.

Paper Feed Roller

1. Paper cassette
2. Clip [A]
3. Push the shaft back through the opening, and tilt it up.

↓ Note

- If the black plastic bushing [B] comes off, make sure you remount it when reinstall the shaft.

4. Paper feed roller [C]

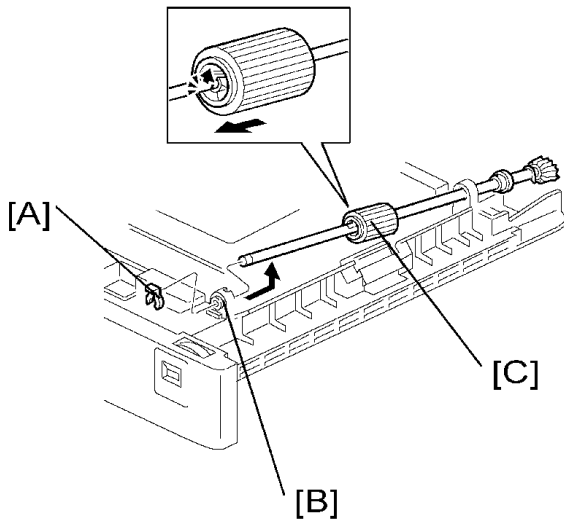

Friction Pad

1. Paper cassette
2. Clip [A]
3. Push the shaft back through the opening, so that the roller moves clear of the friction pad.

4. Friction pad [B]

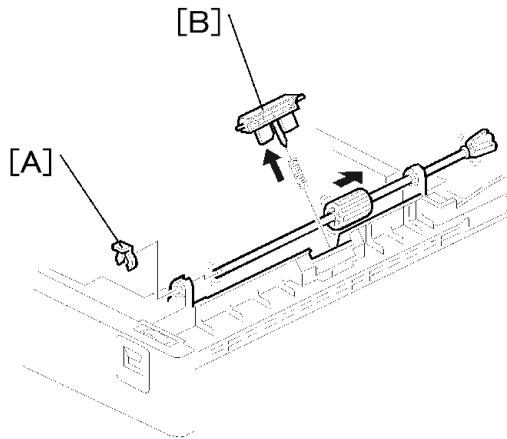

4

Note

- When replacing the friction pad
- Make sure that the mylar [A] does not go under the friction pad when reinstalling the friction pad.
- Do not touch the friction pad with your bare hands when replacing it. If you do, clean the friction pad with a damp cloth or alcohol.

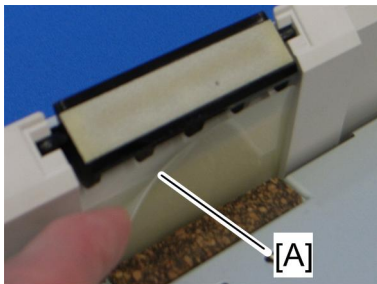

d037i148

Exit Sensor

1. Output tray, exit cover, exit rear cover (☛ p.152)
2. Front right cover (☛ p.160)
3. Operation panel lower cover (D158/D159 only) (☛ p.154)
4. Open the duplex unit.

5. Fusing unit connector bracket [A] (⚙️ x 1, 📌 x 2)

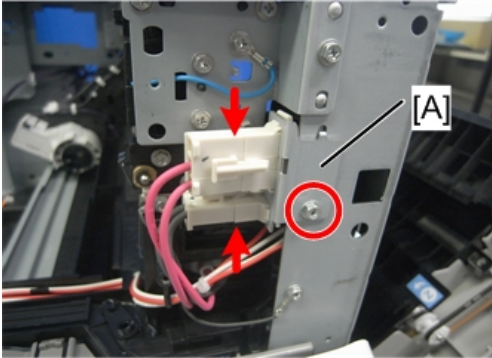

d1582072

6. Upper guide [A] (⚙️ x 2, 📌 x 1, 📌 x 3)

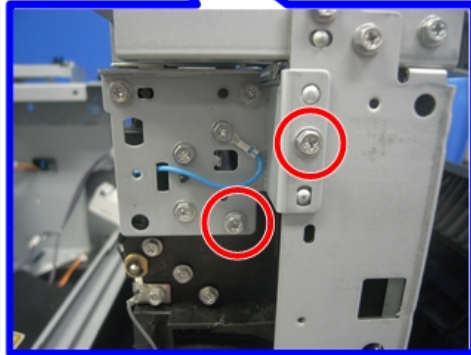
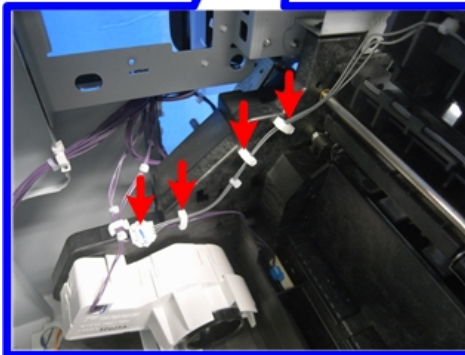
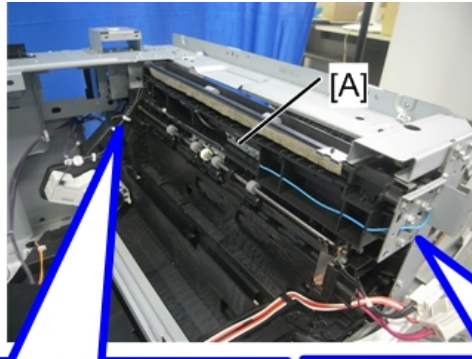

d1582073

7. Guide [A] (🔩 x 2, 📏 x 1)

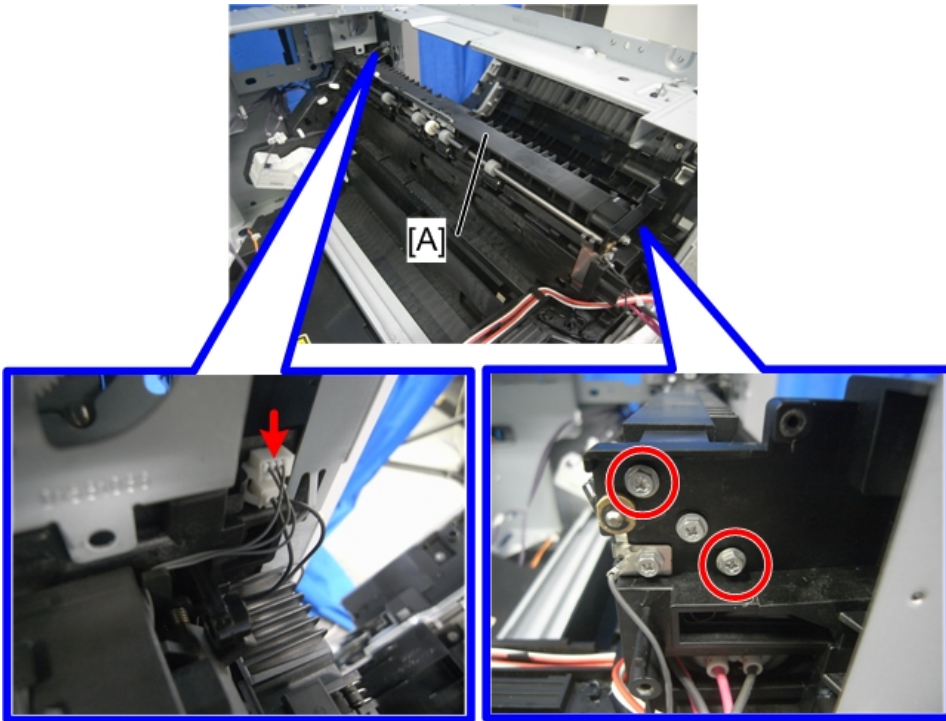

d1582074

8. Exit sensor bracket (🔩 x 1)

9. Exit sensor [A] (📏 x 1)

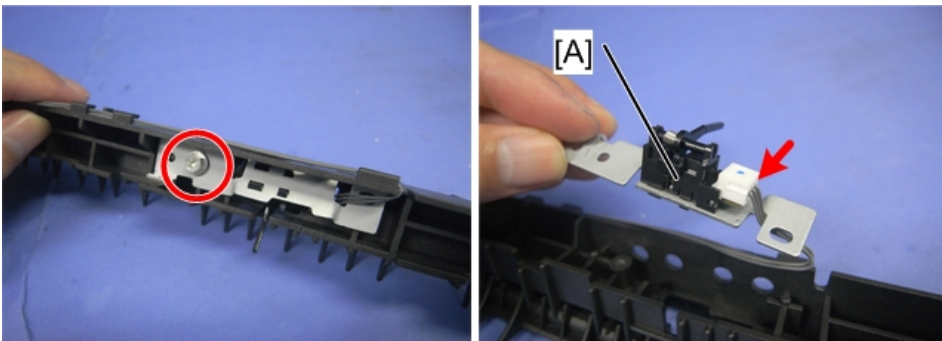

d1582075

Registration Roller

1. PCU (📄 p.200)
2. Front cover (📄 p.159)

3. Right door (☛ p.159)
4. Plastic cover [A]
5. Image transfer roller (☛ p.227)
6. Push down on the notch [B] to free the sensor.
7. Image density sensor [C] (☛ x 1, ☛ x 1)

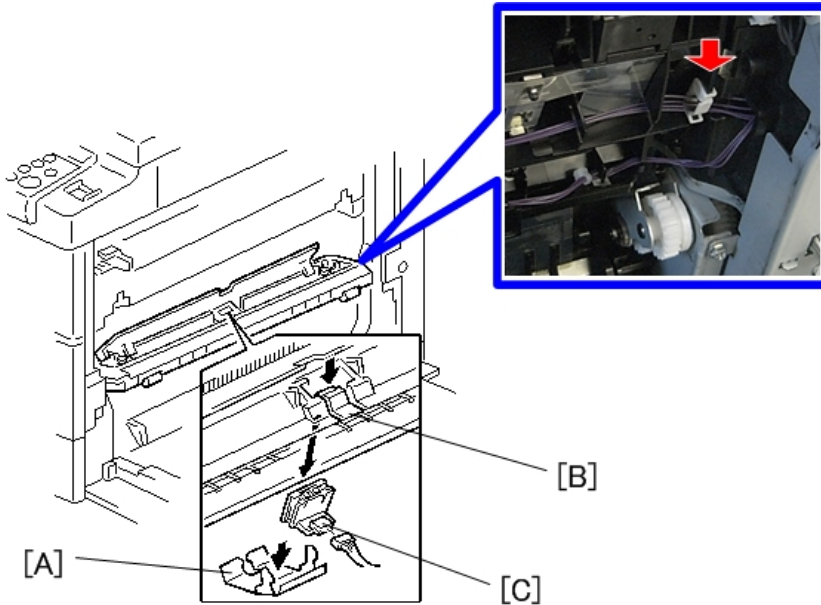

d1585053

8. Rear cover (☛ p.152)
9. High-voltage power supply
10. Registration clutch
11. Unhook the springs [A] and [B] at the rear and front sides.
12. Cover [K] and registration sensor [L] (☛ x 1)
13. Guide support [C] and guide [D] (☛ x 1)
14. Bushing [E] (☛ x 1)
15. Gear [F] and bushing [G] (☛ x 1)
16. Registration roller [H] with the image transfer unit [I]

17. Paper jam release lever [J]

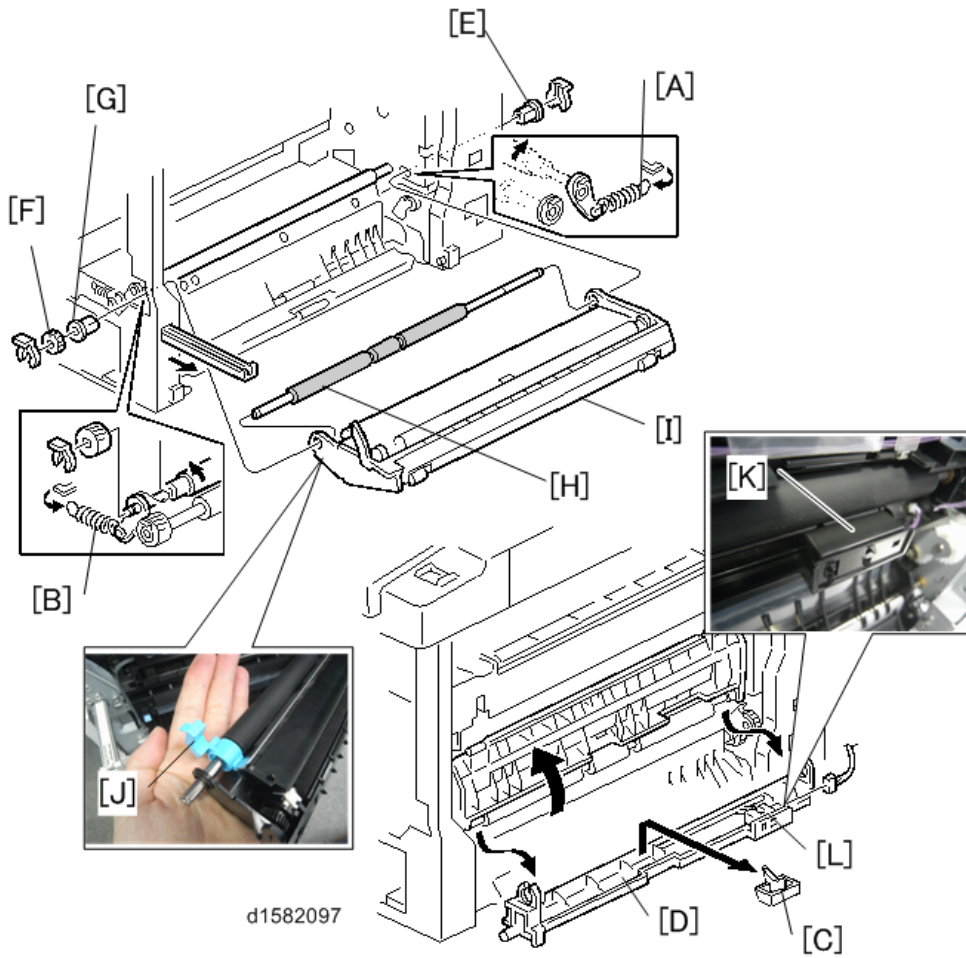

Registration Clutch

1. Rear cover (👉 p.152)

2. High-voltage power supply board (with the bracket) [B] (⚡ x 3, all connectors)

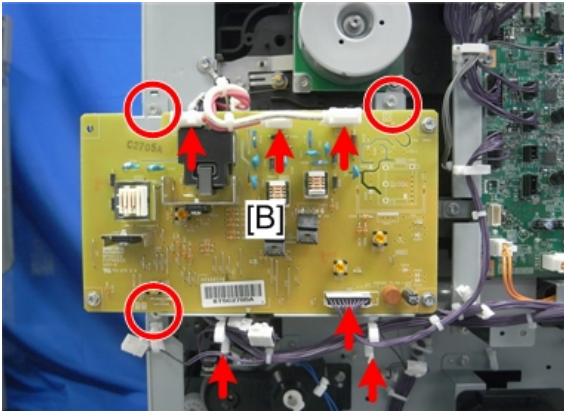

d1582092

3. Registration clutch [A] (⚙️ x 2, 📌 x 1, Clip ring x 1)

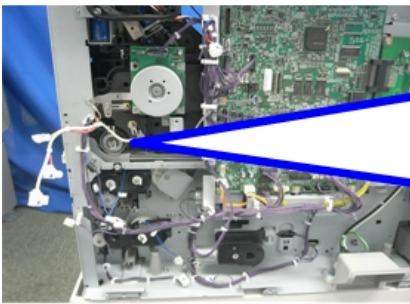

d1582093

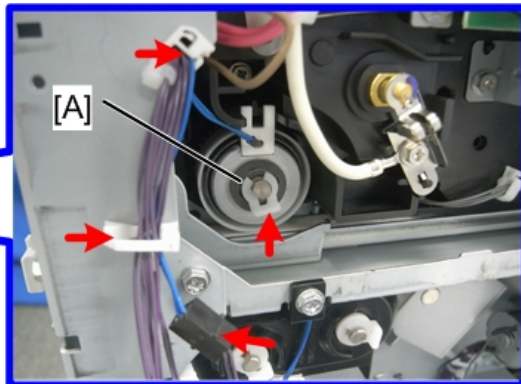

Registration Sensor



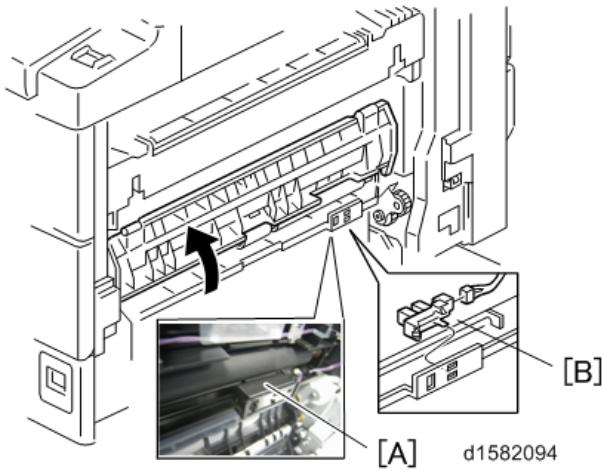

1. Open the right door.
2. Sensor cover [A] (Hook x 2)

3. Registration sensor [B] (x 1)



4

Upper Paper Feed Clutch

1. Rear cover ( p.152)
2. Right rear cover ( p.160 "Right Rear Cover")
3. High-voltage power supply board (with the bracket) [B] ( x 3,  x 4,  x 2)

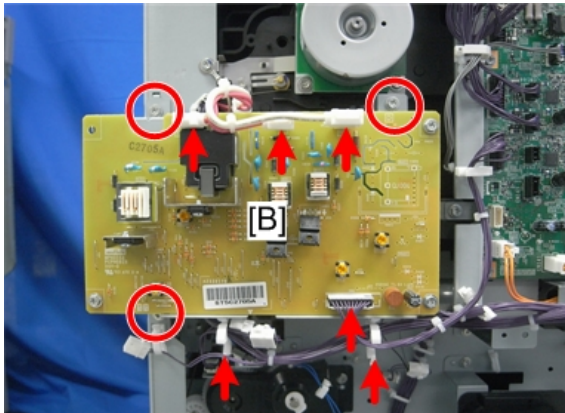

d1582092

4. Clutch cover [A] ( x 2, 2 bushings,  x 2)

5. Paper feed clutch [B] (🔧 x 1)

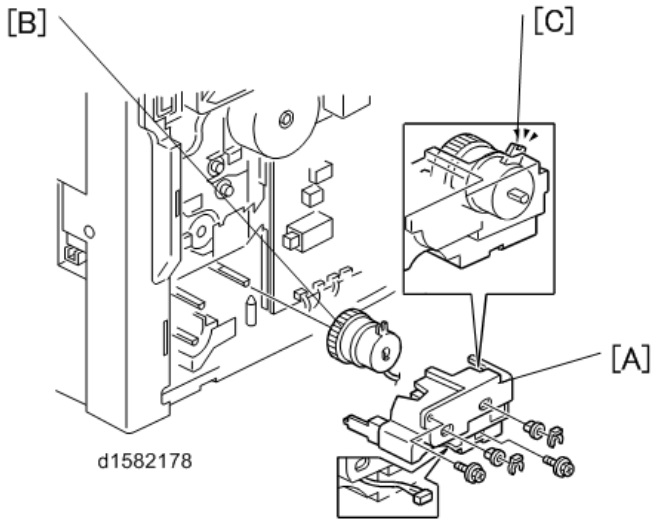

⬇️ Note

- Make sure that the rotation-prevention tabs [C] on the clutches fit correctly into the corresponding openings on the clutch cover when you reinstall.

Relay Clutch

1. Rear cover (🔧 p.152)
2. Relay clutch [A] (🔧 x 1)

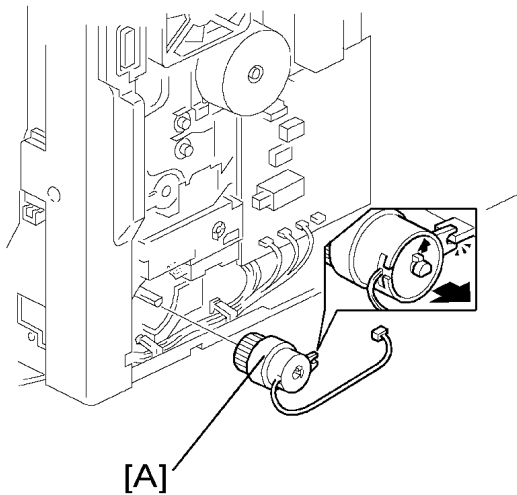

Relay Sensor

1. Relay clutch (● p.216)
2. Sensor bracket [A] (🔩 x 1)
3. Relay sensor [B] (🔩 x 1)

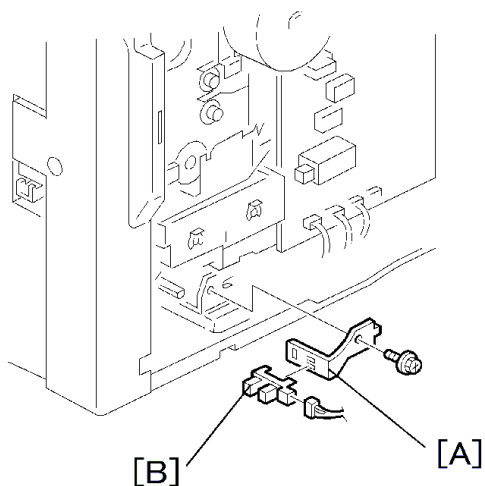

4

Lower Paper Feed Clutch (Two-tray Models Only)

1. Rear cover (● p.152)
2. Clutch Cover [A] (🔩 x 1, Clip ring [B] x 1, Stay [C] x 1)

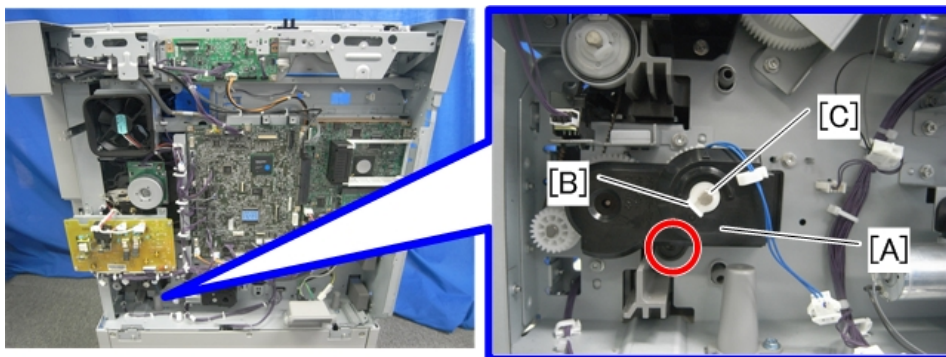

d1582095

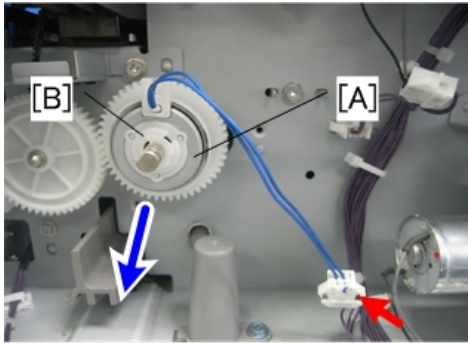

3. Lower paper feed clutch [A] (Clip ring [B] x 1,  x 1)



d1582096

4

Vertical Transport Sensor (Two-tray Models Only)

1. Right lower cover ( p.164)
2. Metal plate [A] ( x 3)
3. Vertical transport sensor [B] ( x 1)

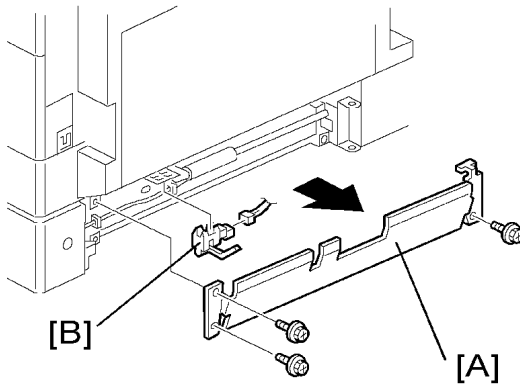

Paper Size Switch

1. Paper tray 1 and 2
 - Paper size switch: T1 [A]
 - Paper size switch: T2 [B] (Two-tray Models Only)

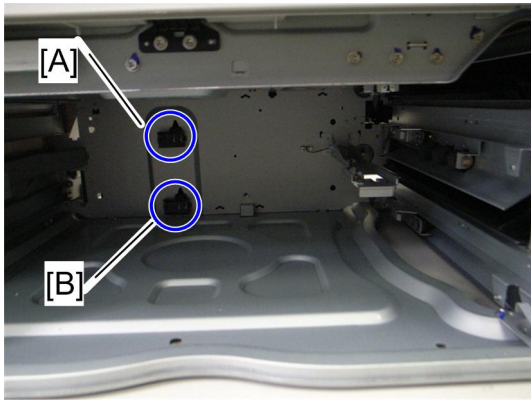

d037r351

2. Paper size switch [A] (hooks,  x 1)

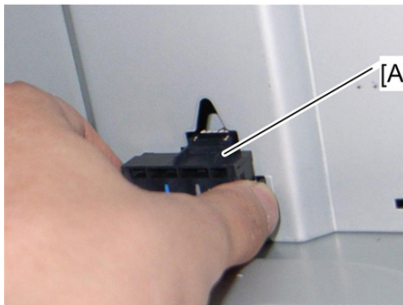

d037r352

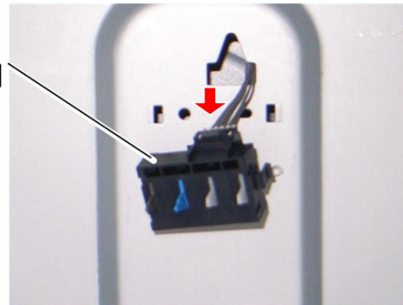

d037r353

Paper End Sensor

Paper End Sensor: T1

1. Paper tray 1 and 2
2. Paper end sensor: T1 [A] (hooks,  x 1)

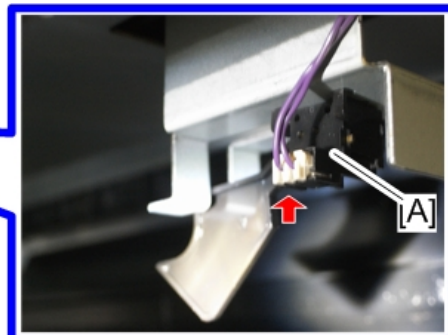
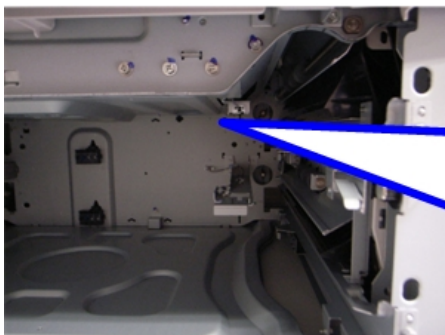

d1585045

Paper End Sensor: T2 (Two-tray Models Only)

1. Paper tray 1 and 2
2. Paper end sensor: T2 [A] (hooks,  x 1)

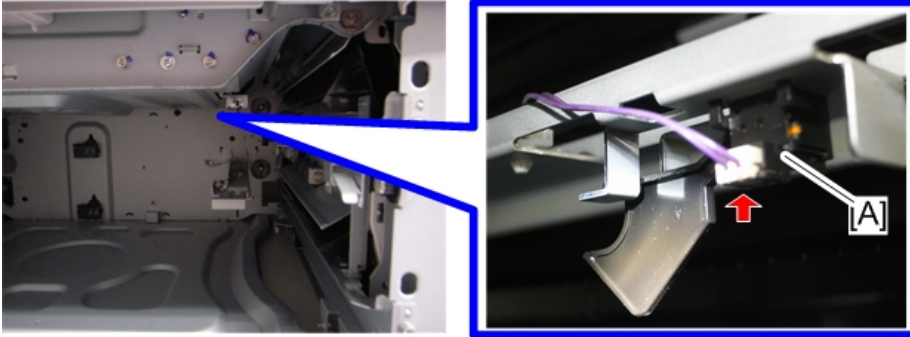

d1585046

4

Tray Lift Motor

1. Rear cover ( p.152)
 - Tray 1 lift motor [A]
 - Tray 2 lift motor [B] (Two-tray Models Only)

Note

- When replacing the tray 1 lift motor [A], it is necessary to remove the BICU ( p.248).

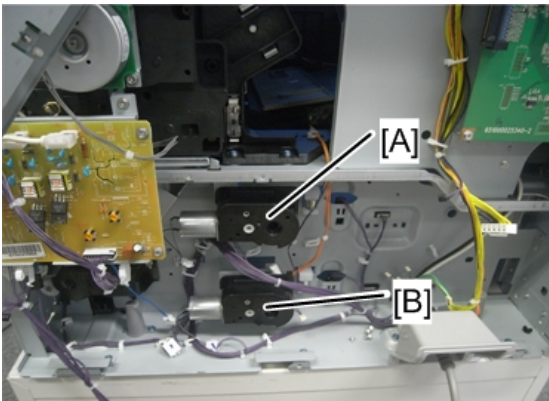

d1582131

2. Motor bracket [A] (with gear unit) ( x 3,  x 1)

3. Gear cover [B] (⚙️ x 2)

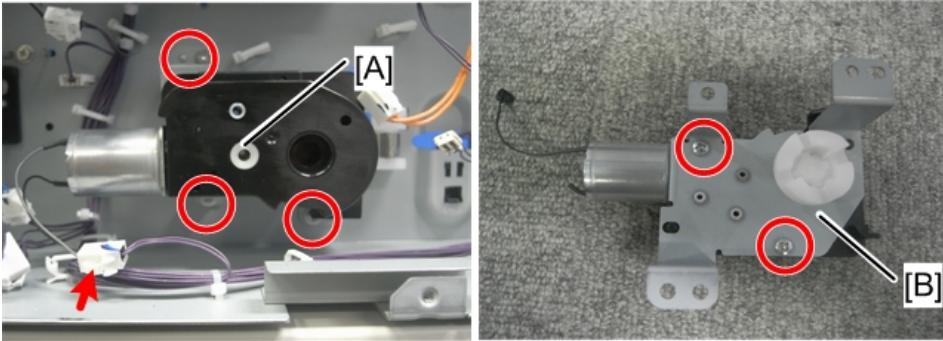

d1582132

4. Tray lift motor [A] (⚙️ x 2)

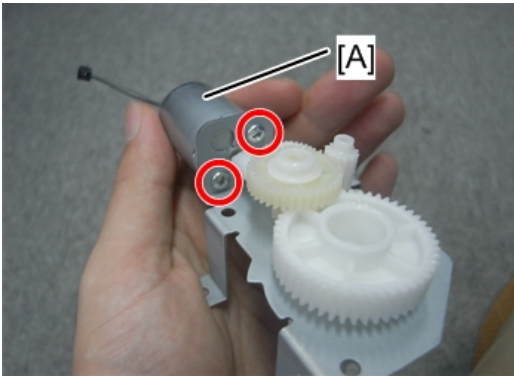

d1582133

4

Tray Lift Sensor

1. Rear cover (🔧 p.152)

Tray 1 lift sensor [A]

Tray 2 lift sensor [B] (Two-tray Models Only)

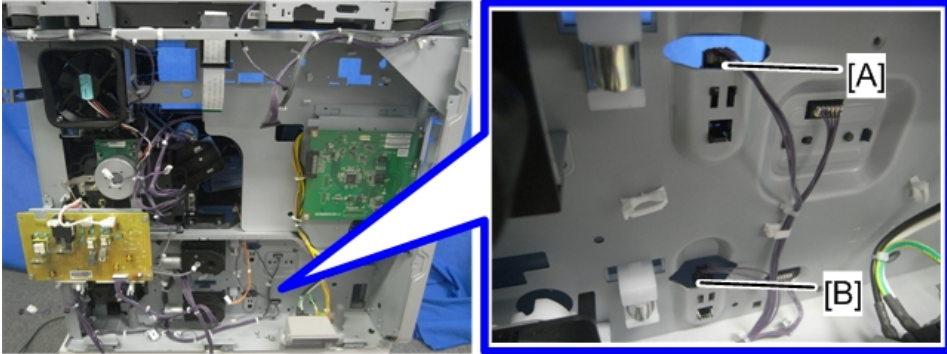

d1582134

4

2. Tray lift sensor ( x 1, Hook x3)

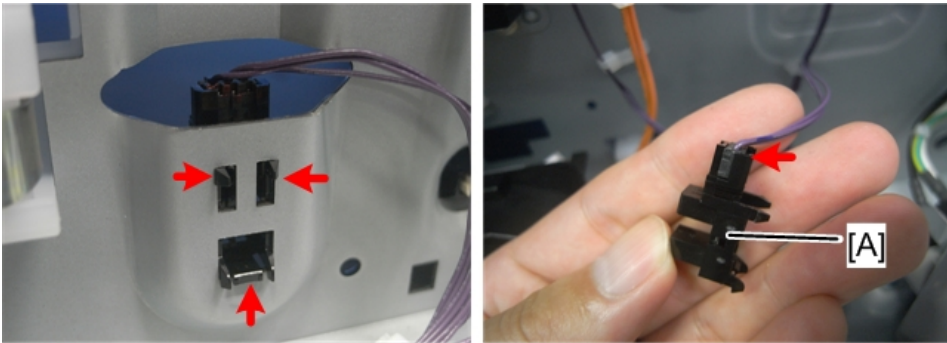

d1582135

By-pass Paper Length Sensor

1. Open the by-pass tray unit.
2. By-pass tray right cover [A] ( x 2)

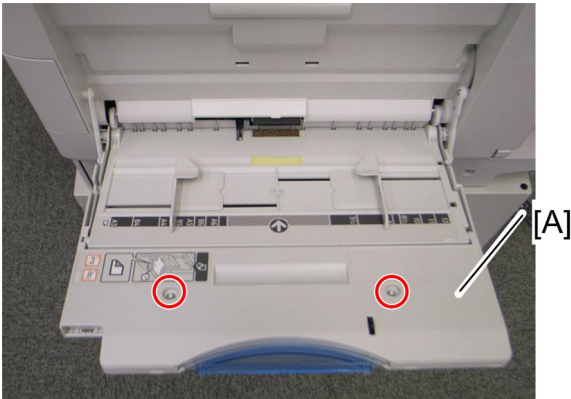

d037r290

3. By-pass paper length sensor [A] (☐ x 1)

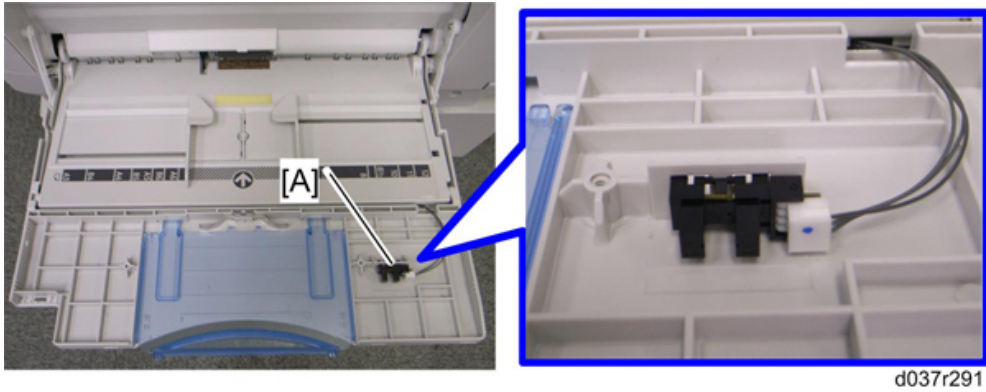

d037r291

4

By-Pass Paper Width Sensor

1. By-pass tray unit (☛ p.162)
2. By-pass left tray cover [A] (hook x 1)

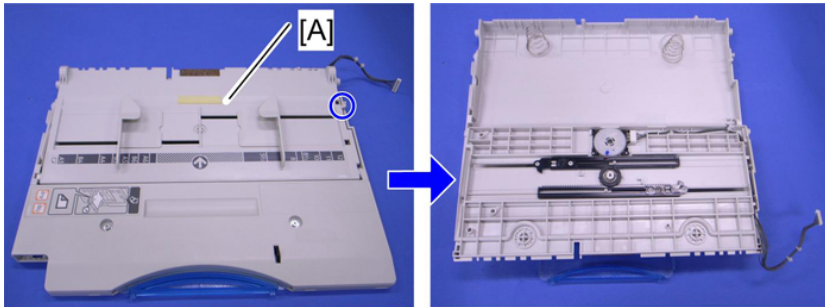

d037r292

3. Replace the by-pass paper width sensor [A] (☐ x 1).

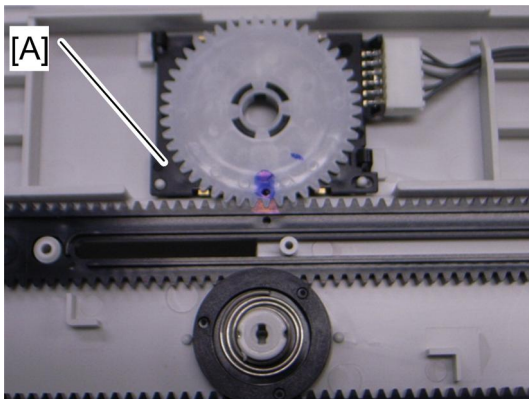

d037r293

When replacing the by-pass paper width sensor

1. Align the holes [A], [B] and [C].
2. Install the by-pass paper width sensor [D].

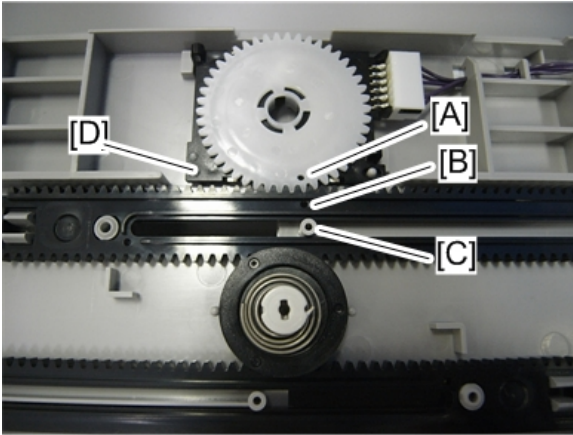

d1585048

3. Reassemble the copier.
4. Plug in and turn on the main power switch.
5. Check the switch operation with SP5-803-046 (By-Pass Size Detection SW < Input Check).

- Display on the LCD -

Paper Size	Display	Paper Size	Display
A3 SEF	00001001	A5 SEF	00001110
B4 SEF	00001011	B6 SEF	00001100
A4 SEF	00000011	A6 SEF	00001101
B5 SEF	00000111	Smaller A6 SEF	00001101

By-Pass Feed Roller and By-Pass Paper End Sensor

1. By-pass tray unit (☛ p.162)

⚠ Note

- If you have a support to keep the by-pass tray within the reach of the connector cable, you do not need to disconnect the connector. When you do so, use caution not to place too much load on the cable.

2. Sensor holder [A]

3. By-pass paper end sensor [B] (🔌 x 1)
4. By-pass feed roller [C]

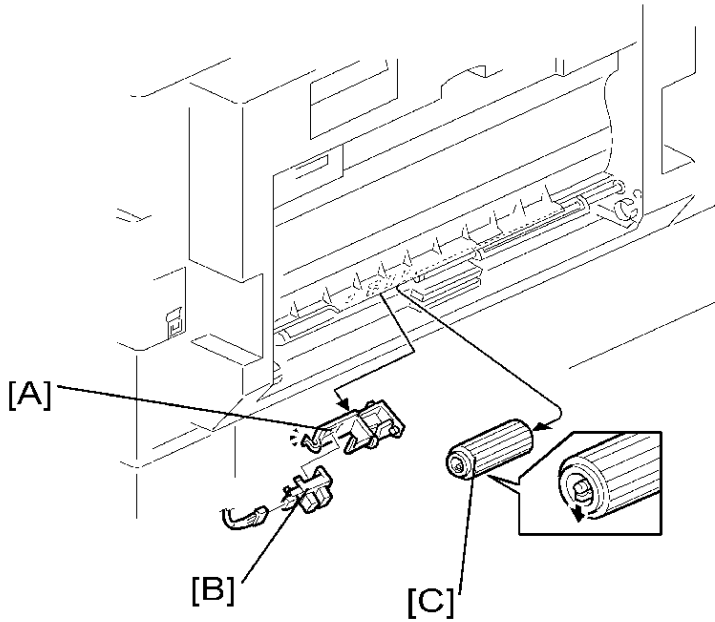

4

By-pass Feed Clutch and By-pass Tray Lift Clutch

1. Duplex unit (or right door) (🔧 p.161)
2. Clutch cover [A] (🔧 x 2, 🌀 x2, 📏 x 1)

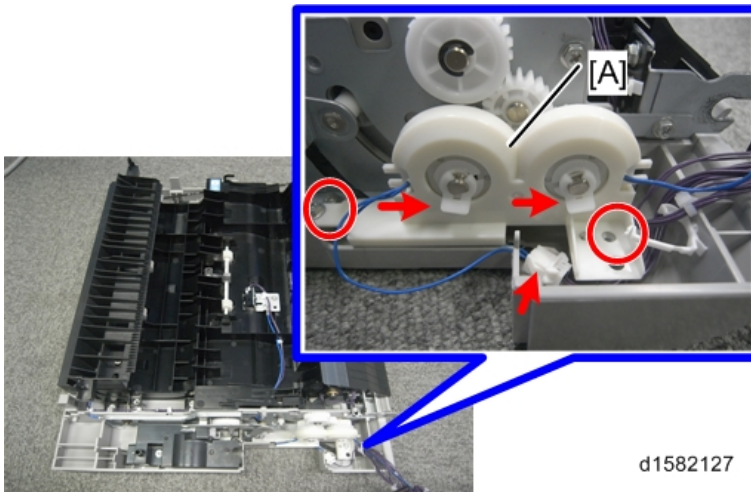

3. By-pass tray lift clutch [A]

4. By-pass feed clutch [B]

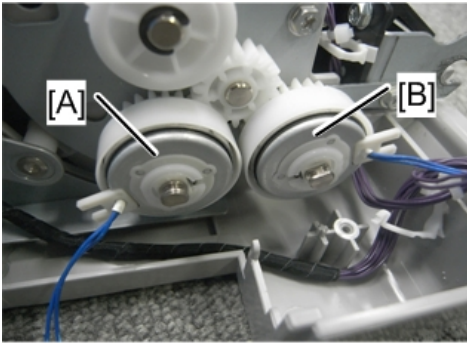

d1582128

By-pass Tray Lift Sensor

1. Duplex unit (or right door) (☞ p.161)
2. Sensor cover [A] (☞ x 1)

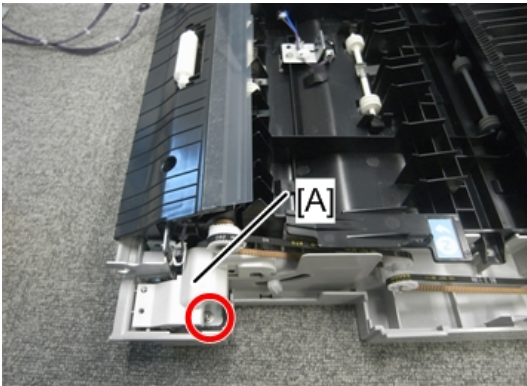

d1582128

3. By-pass tray lift sensor [A] (☞ x 1, Hook x 3)

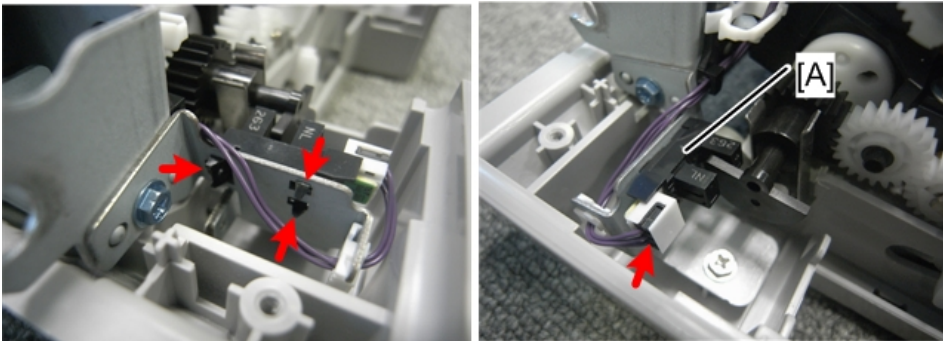

d1582130

Image Transfer

★ Important

- Unplug the machine power cord before starting the following procedures.

Image Transfer Roller

⚠ CAUTION

- Do not touch the transfer roller surface with bare hands

1. Open the right door.
2. Lift the plastic holders [D] with the image transfer roller [B].

↓ Note

- Leave the springs under the holders. Make sure that the pegs [C] on the holders [A] engage with the springs when you reassemble.

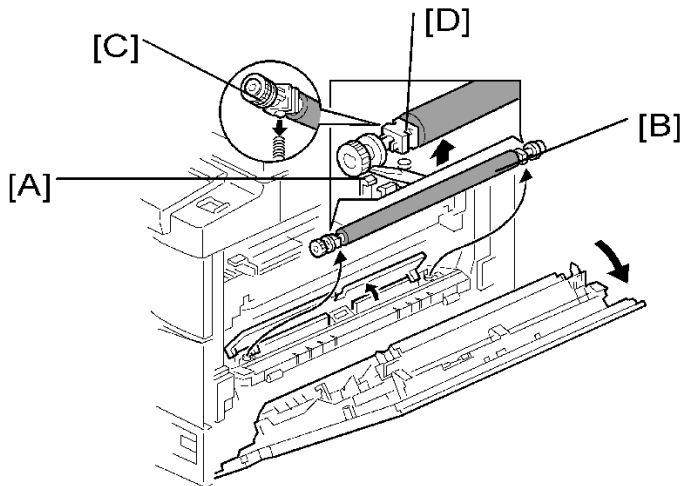
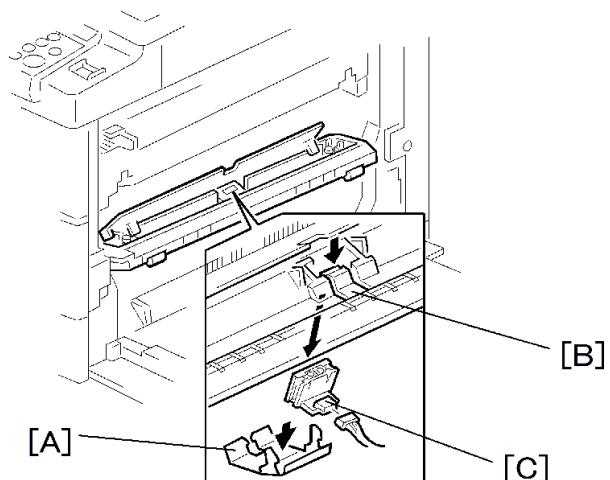

Image Density Sensor

1. Open the right door.
2. Plastic cover [A]
3. Image transfer roller (☛ p.227)
4. Push down on the notch [B] to free the sensor.

5. Image density sensor [C] (🖨️ x 1)



Fusing

★ Important

- Unplug the machine power cord before starting the following procedures.

Fusing Unit

⚠ CAUTION

- The fusing unit can become very hot. Make sure that it has cooled down sufficiently before you handle it.
1. Turn off the main switch, and unplug the machine.
 2. Front right cover (☛ p.160)
 3. Open the right door.
 4. Fusing unit [A] (🔧 x 2, 📦 x 4)

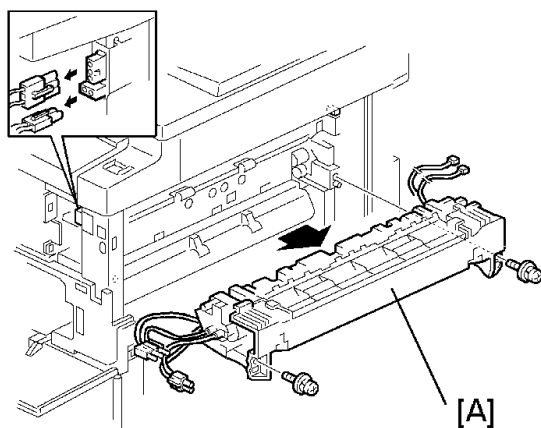

Thermistor

1. Fusing unit (☛ p.229)

2. Thermistors [A] (🔩 x 2, 📏 x 2)

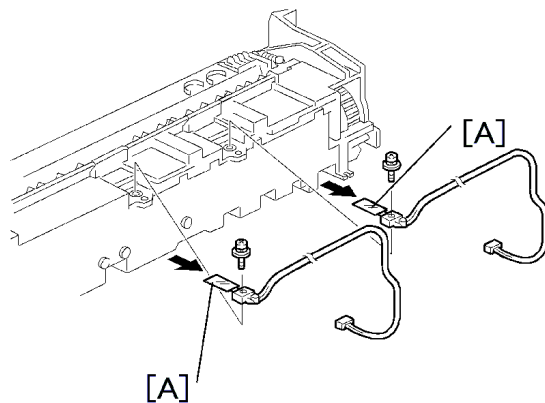

4

Fusing Lamps

1. Fusing unit (📄 p.229)
2. Separate the hot roller section [A] from the pressure roller section [B] (🔩 x 4).
3. Front holding plate [C] (🔩 x 1)

4. Rear holding plate [D] (🔩 x 1)

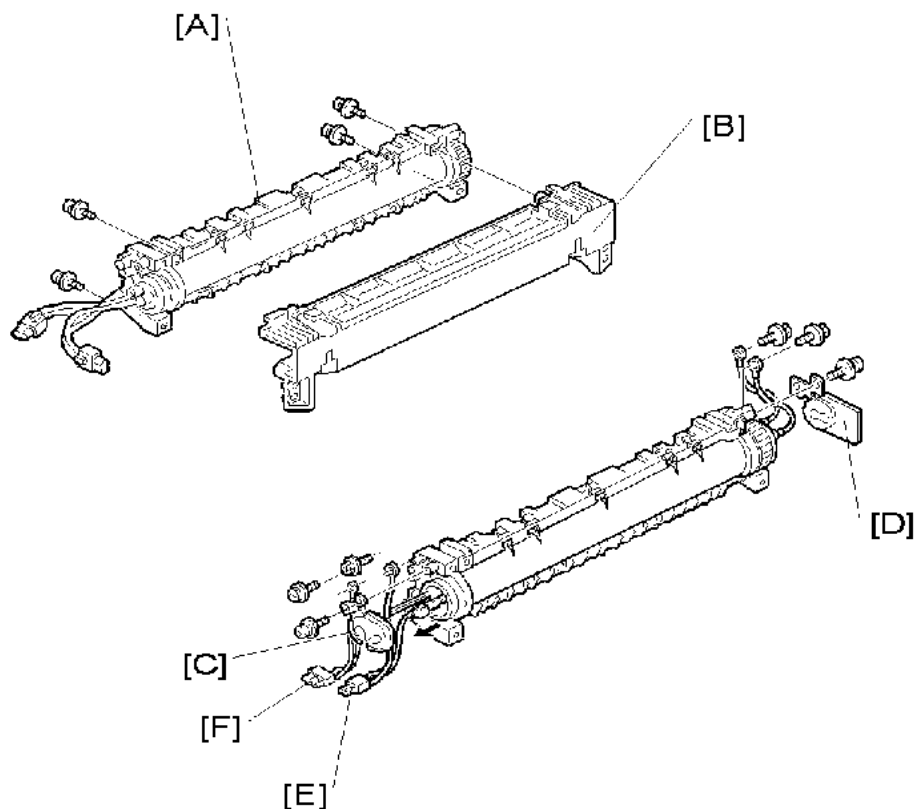

5. Fusing lamp with the connector (600W) [E] (🔩 x 2)

6. Fusing lamp with the connector (550W) [F] (🔩 x 2)

⬇️ Note

- Check that the front ends of the two lamps fit in the front holding plate when you reassemble. They do not fit in there if you arrange the two lamps incorrectly.

Hot Roller Stripper Pawls

1. Hot roller section (🔩 p.230 "Fusing Lamps")

2. Roller guard [A] (🔩 x 3)

3. Metal holders [B] (1 holder for each)

4. Hot roller stripper pawls [C] (1 spring for each)

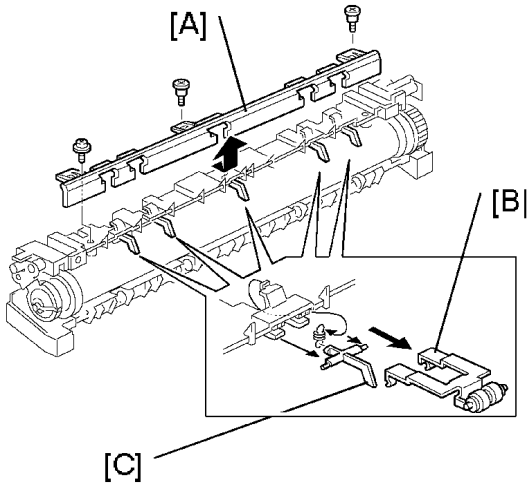

4

Hot Roller

1. Hot roller stripper pawls (☛ p.231)
2. Hot roller [A] (2 C-rings, 1 gear, 2 bearings)

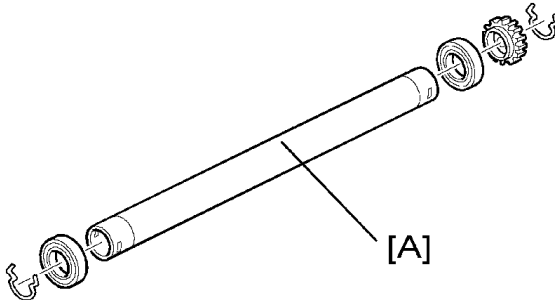

Thermostat

1. Hot roller (☛ p.232)

2. Thermostat [A] (🔩 x 2 for each)

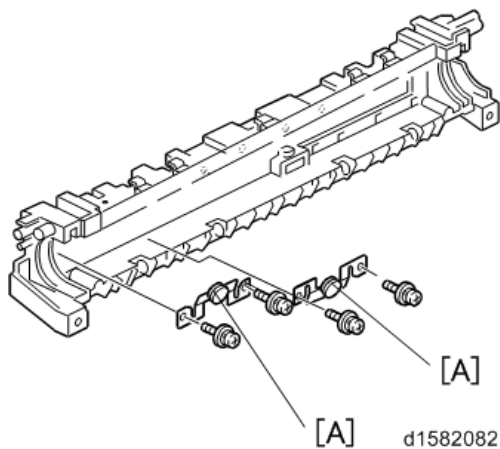

Pressure Roller and Bushings

1. Separate the hot roller section from the pressure roller section (🔧 p.230 "Fusing Lamps").
2. Fusing entrance guide [A] (🔩 x 2)
3. 2 springs [B]
4. 2 pressure arms [C]
5. 2 Bushings [D]

6. Pressure roller [E]

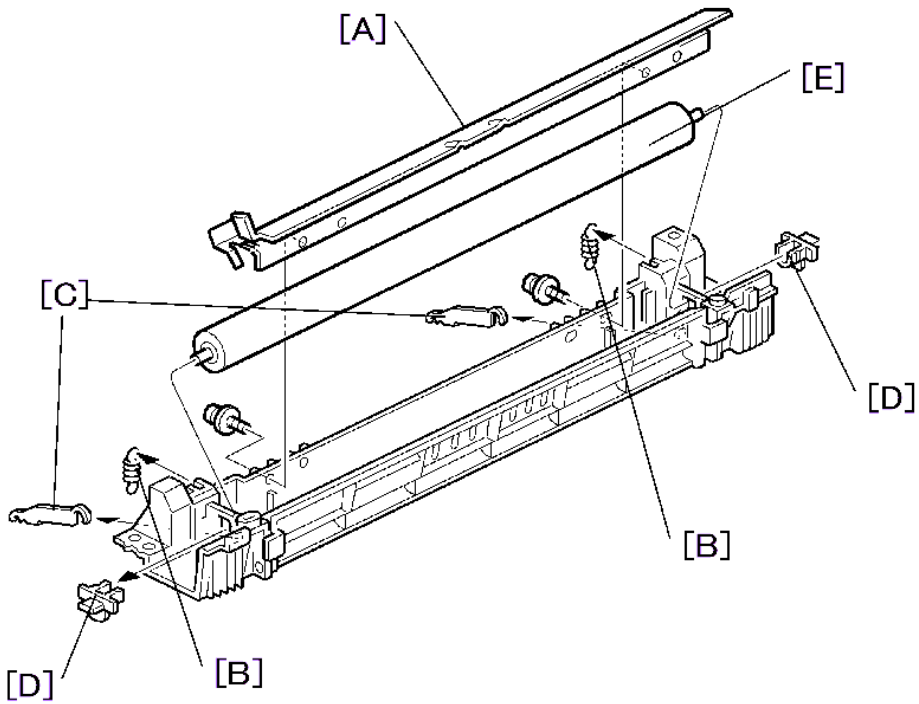



4

NIP Band Width Adjustment

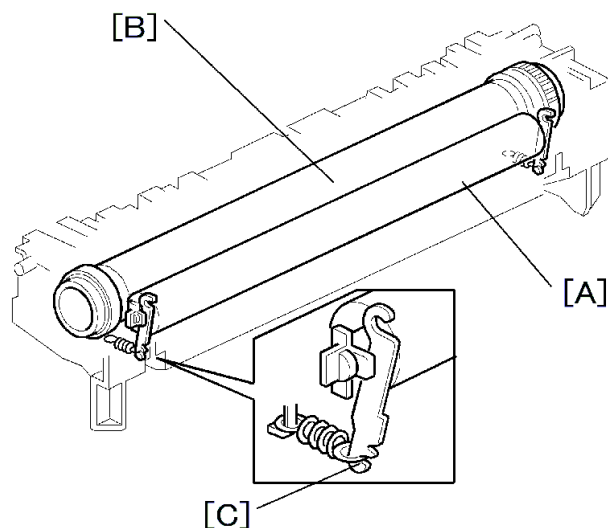
Do this adjustment when the fusing unit is at its operating temperature. The size of the OHP sheet must be A4/LT LEF. Any other sizes may cause a paper jam.



- [A] Pressure roller
- [B] Hot roller
- [C] Spring hook

1. Place an OHP sheet on the by-pass feed table.
2. Enter SP mode, and run SP 1-152-001 (Fusing Nip Band Check).
3. Press '1' (Yes), or "Execute".
4. Press  twice. The machine feeds the OHP sheet into the by-pass feed, stops it at the registration roller for 300 seconds, then 20 seconds in the fusing unit.
5. Check that the OHP sheet is ejected to the copy tray.
6. Press the  key.
7. Quit the SP mode.
8. Check that the nip band (the opaque stripe) across the ejected OHP sheet is symmetrical, with both ends slightly thicker than the center.

 **Note**

- There is no standard value for the nip band on this machine. Make the adjustment based on the band's appearance.
9. If the band is not as described above, change the position of the spring hooks [C] (one on each side), and then check the band again.

 **Note**

- The higher hook position produces greater tension.

Duplex Unit (Duplex Models Only)

★ Important

- Unplug the machine power cord before starting the following procedures.

↓ Note

- Duplex models - D158, D159, D160, D161
- Non-duplex model - D170

Duplex Exit Sensor

4

1. Open the right door.
2. Sensor bracket [A] (🔩 x 1)

↓ Note

- Another bracket [B] comes off with the sensor bracket.

3. Duplex exit sensor [C] (🔩 x 1)

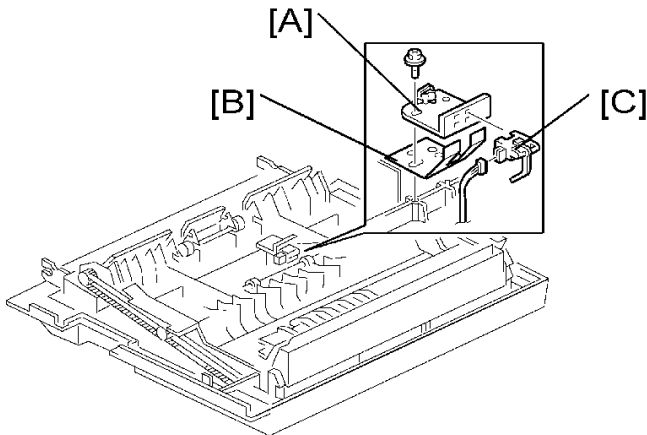

Duplex Entrance Sensor

1. Open the right door.
2. Lift the duplex guide [A].
3. Entrance sensor bracket [B] and bracket cover [C] (🔩 x 2)

4. Duplex entrance sensor [D]

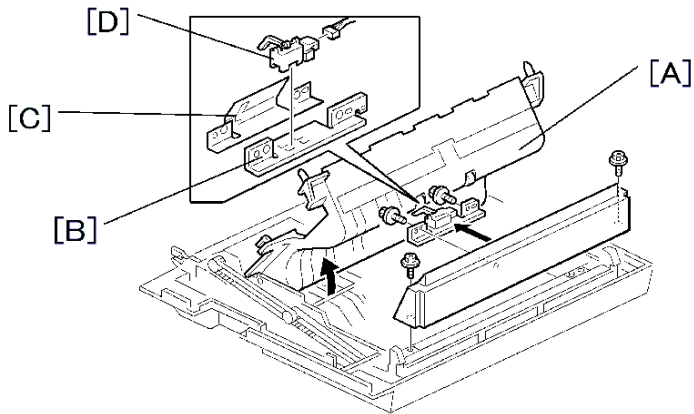

4

Duplex Inverter Sensor

1. Copy tray [A] (🔩 x 2)
2. Exit cover [B] (🔩 x 1)
3. Sensor bracket [C] (🔩 x 1, 📦 x 1)
4. Duplex inverter sensor [D] (🔩 x 1)

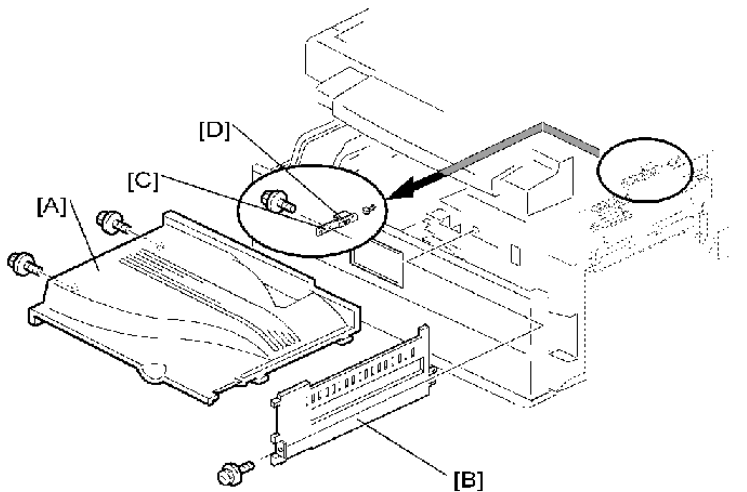

Duplex Transport Motor

1. Open the right door.
2. Detach the chain and spring from the frame, and lower the right door.

3. Cover [A] (🔩 x 1)
4. Motor bracket [B] (🔩 x 4, 📏 x 1).
5. Duplex transport motor [C] (🔩 x 2)

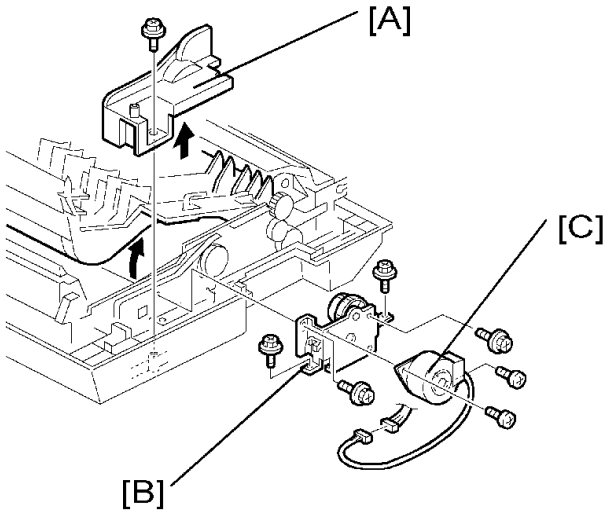

Duplex Inverter Motor

1. Platen cover, or ARDF (if installed)
2. Rear cover (📄 p.152)
3. Top rear cover (📄 p.153)
4. Bracket [A] (🔩 x 4)

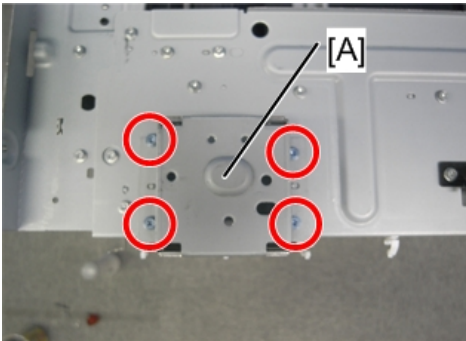

d1582079

5. Rear exhaust fan [A] (🔧 x 3)

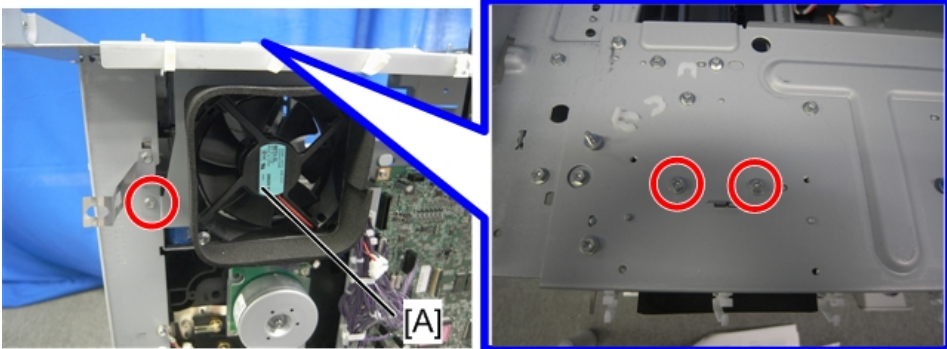

d1582080

6. Duplex inverter motor [A] (🔧 x 2, 📏 x 1)

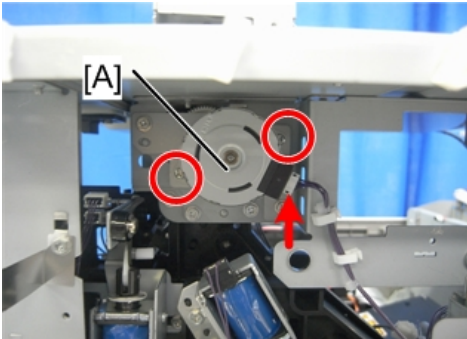

d1582081

Electrical Components

★ Important

- Unplug the machine power cord before starting the following procedures.

Controller Board (GW+/GDI)

⚠ CAUTION

- The battery on the control board can explode if replaced incorrectly.
- Dispose of the old battery in accordance with the instructions.

4

Types of Controller board

There are two types of controller, depending on the machine.

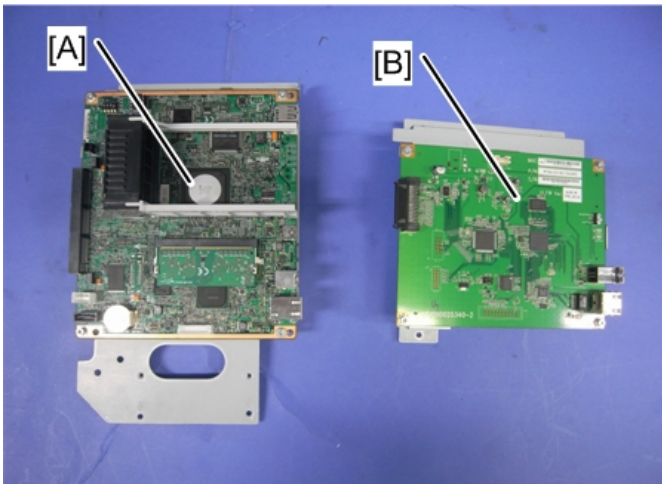

d1582100

- GW+ controller board [A]: D158/D159
- GDI controller board [B]: D160/D161
- No controller board : D170

Replacement Procedure (GW+ Controller)

Before Replacing the GW+ Controller Board in the Model without HDD

When you replace the controller board in a model without a HDD, address book data can be copied from an old controller board to a new controller board using an SD card.

Copy the address book data to an SD card from the flash ROM on the controller board with SP5846-051 if possible.

1. Rear cover (☛ p.152)
2. Separate the BICU [A] from the CTL board [B] (🔧 x 5, 📧 x 2).

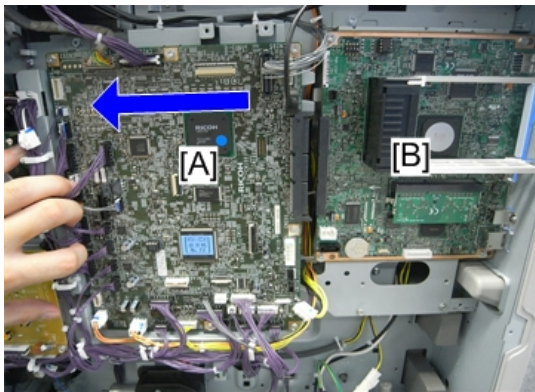
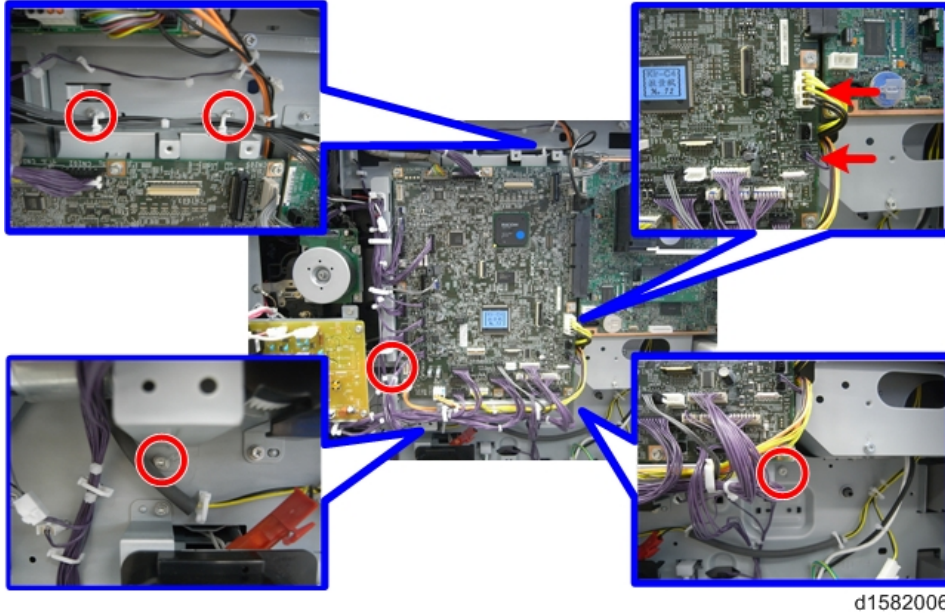

3. CTL board [A] (with bracket) (⚙️ x 3)

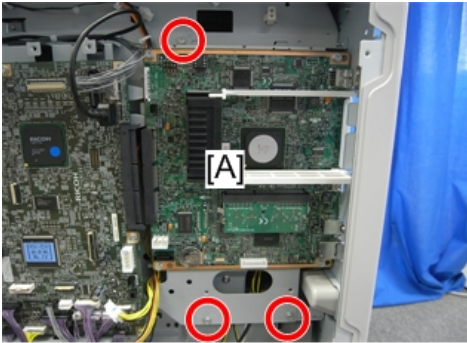

d1583008

4. Slide the CTL board [A] to the left and pull down as shown below.

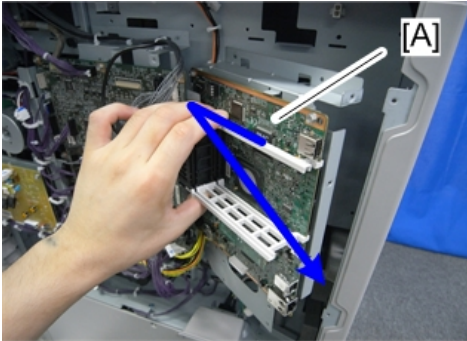

d1582009

5. NVRAM [A]

6. DIMM-RAM [B]

7. CTL board (⚙️ x 4) [C]

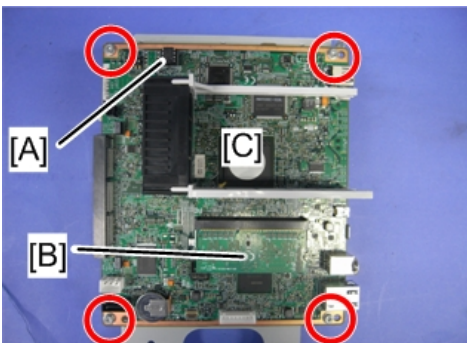

d1582101

8. Install the new CTL board.

When Replacing the New Controller Board (GW+ Controller)

1. Remove the NVRAM [A] from the old controller board.

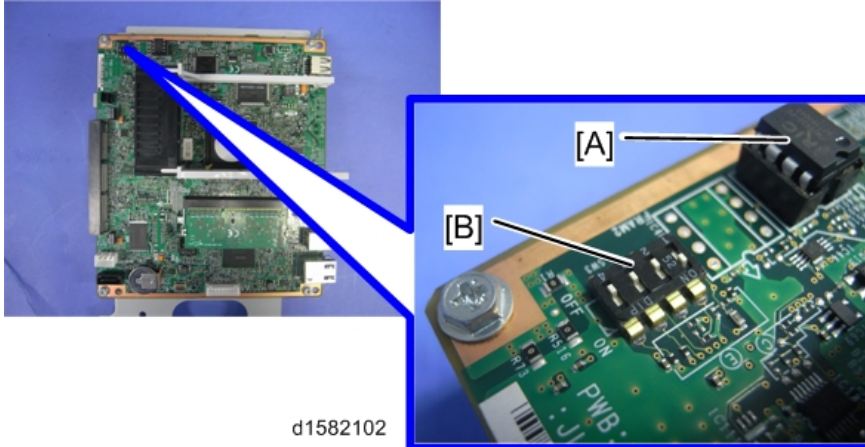

2. Install the old NVRAM [A] on the new controller board after you replace the controller board.
3. Replace the NVRAM if the NVRAM on the old controller board is defective.

↓ Note

- Make sure you print out the SMC reports ("SP Mode Data" and "Logging Data") before you replace the NVRAM.

⚠ CAUTION

- Keep NVRAM away from any objects that can cause static electricity. Static electricity can damage NVRAM data.
- Make sure the NVRAM are correctly installed on the controller board.
- Make sure that the DIP-switch [B] settings on the old controller board are the same for the new controller board. Do not change the DIP switches on the controller board in the field.

After Installing the Controller Board (GW+ Controller)

1. For a model without a HDD, do SP5-846-052 to copy back the address book to the flash ROM on the controller board from the SD card to which you have already copied the address book data if possible.
2. For a model with a HDD, if the customer is using the data encryption feature, the encryption key must be restored.
3. Turn the main power switch off/on.

Replacement Procedure (GDI Controller)

1. Rear cover (☛ p.152)

2. Interface cover [A]

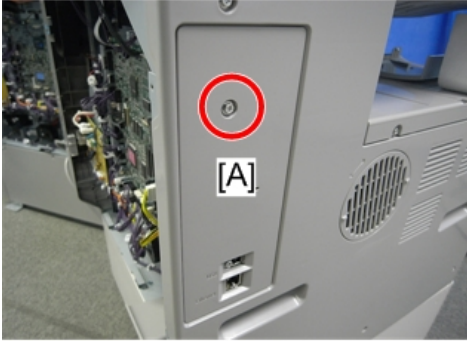

d1582013

3. Separate the BICU [A] from the CTL board (☛ x 5).

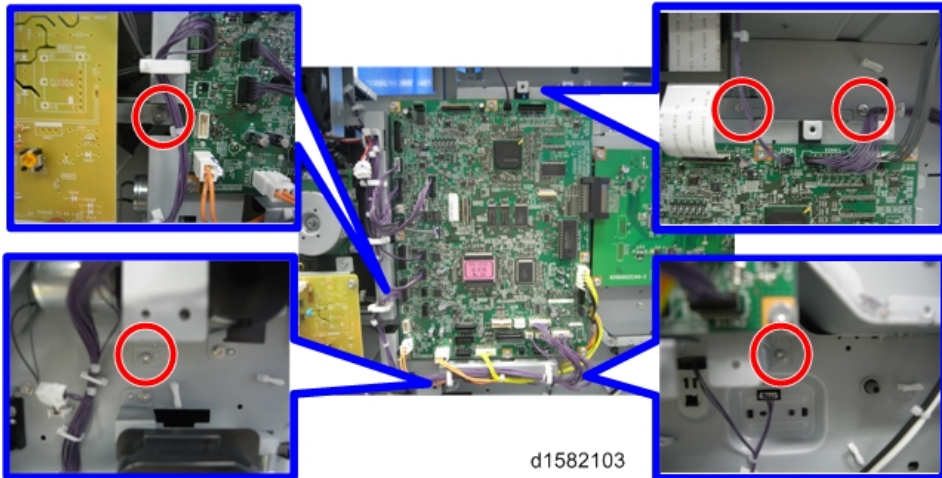

d1582103

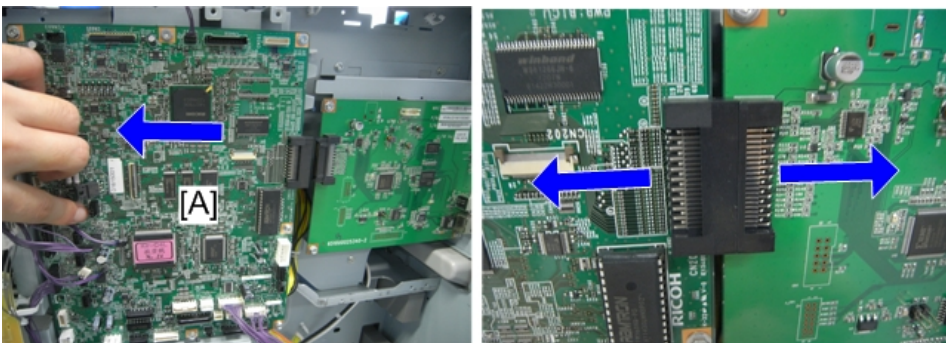

d1582104

4. CTL board [A] (with bracket) (⚙️ x 5)



d1582016

5. CTL board [A] (⚙️ x 4)

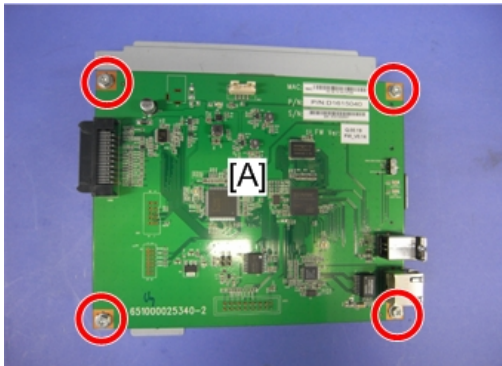

d1582105

6. Install the new CTL board.

When Replacing the New Controller Board (GDI)

There is no removable NV-RAM on the CTL board. When the controller board is replaced, it is necessary to re-enter the information manually.

1. Do SP5-990-002 (SP) and SP5-990-003 (User Program) before you replace the controller board.
2. After replacing the controller board, enter all the SP/UP data manually.

⚠️ Note

- If you cannot print the SMC data lists, refer to the factory SMC lists, and enter the values.

HDD Unit (for D158/D159)

★ Important

- Unplug the machine power cord before starting the following procedure.

Before Replacing the HDD Unit:

- Copy the address book data to an SD card from the HDD with SP5-846-051 if possible.

Disposal of HDD Units:

- Never remove an HDD unit from the work site without the consent of the client.
- If the customer has any concerns about the security of any information on the HDD, the HDD must remain with the customer for disposal or safe keeping.
- The HDD may contain proprietary or classified (Confidential, Secret) information. Specifically, the HDD contains document server documents and data stored in temporary files created automatically during copy job sorting and jam recovery. Such data is stored on the HDD in a special format so it cannot normally be read but can be recovered with illegal methods.

4

Replacement:

- Explain to the customer that the following information stored on the HDD is lost when the HDD is replaced: document server documents, fixed stamps, document server address book
- The address book and document server documents (if needed) must be input again.

Replacement Procedure

1. The HDD [A] is attached behind the controller board.

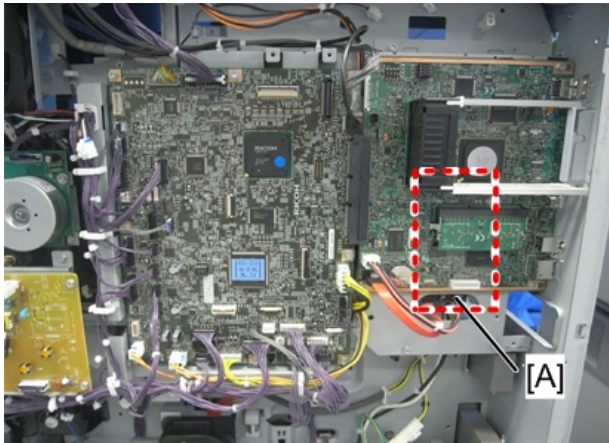

d1582106

2. Rear cover (🔧 p.152)
3. Controller board (with bracket) (🔧 p.240)

4. Replace the HDD [A] (🔧 x 4, 📏 x 2)

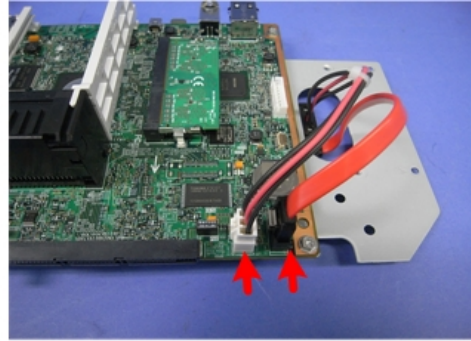
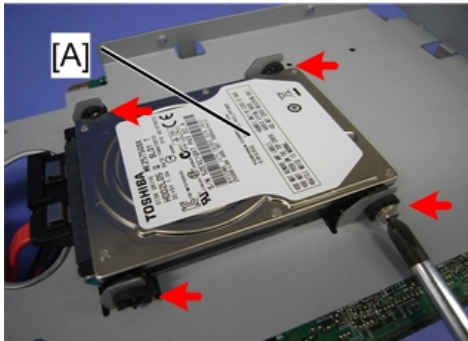

d1582107

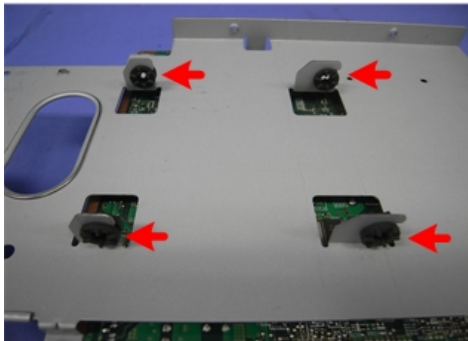

5. When you turn the main power switch on after installing the hard disk, initialization of the disk starts automatically.
6. Once a completion message appears, turn the power off.
7. Download the address book data to an SD card.

Quenching Lamp

1. PCU (🔧 p.200)

2. Quenching lamp [A] (🔌 x 1)

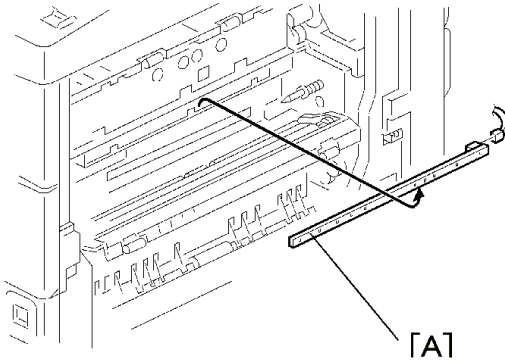

4

High-Voltage Power Supply Board

1. Rear cover (🔑 p.152)
2. Right rear cover (🔑 p.160)
3. High-voltage power supply board [A] (🔌 x 3, 🔌 x 4)

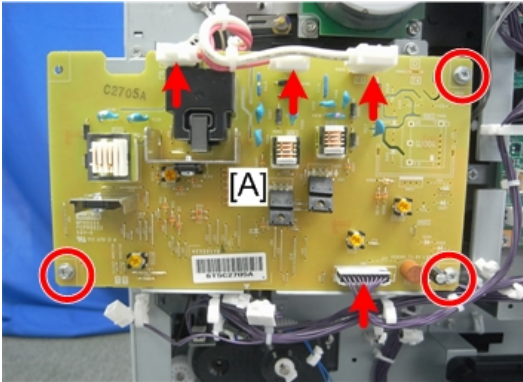

d1582083

BICU (Base-Engine Image Control Unit)

1. Rear cover (🔑 p.152)

2. Separate the BICU [A] from the CTL board [B] (⚡ x 5, 🗑️ x 2).

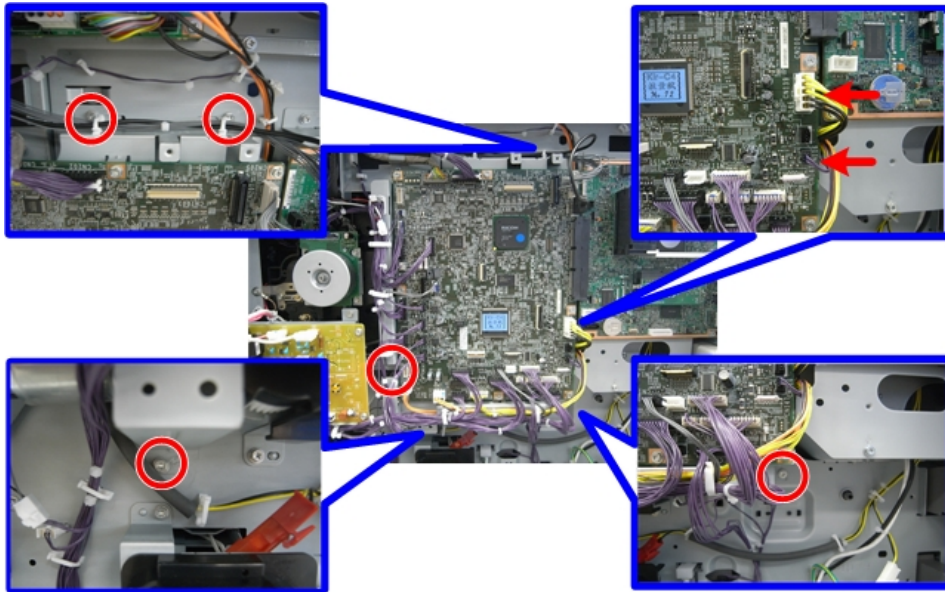

d1582006

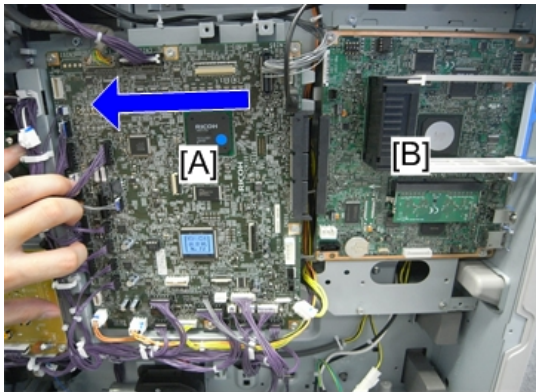

d1582007

3. BICU [A] (🔧 x 8, 📁 All).

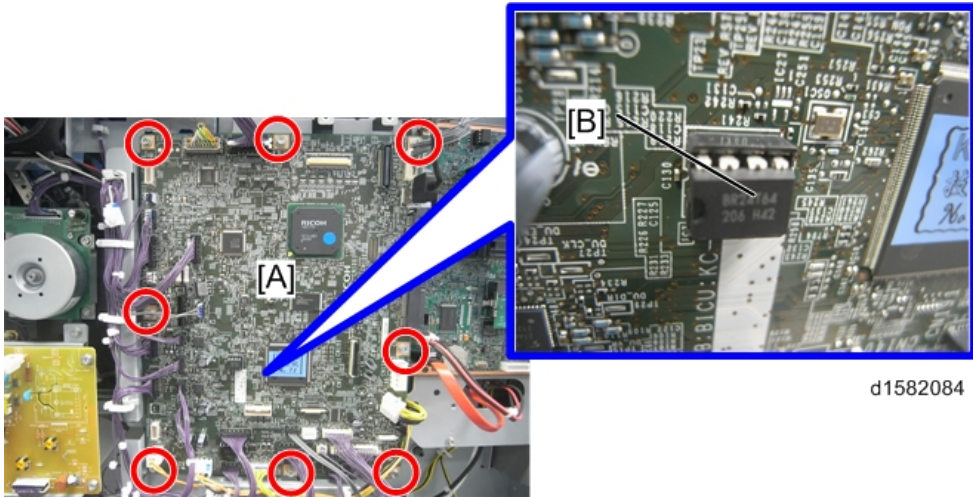

d1582084

↓ Note

- Remove the NVRAM [B] from the old BICU and install it on the new BICU when you replace the BICU. The NVRAM keeps machine-specific data.

Replacing the NVRAM on the BICU

1. Replace the NVRAM if the NVRAM on the old BICU board is defective.
2. After replacing the NVRAM, clear the engine NVRAM with SP5801-002. Then input the following values from the most recent SMC list:
 - SP4-609-001, 002
 - SP4-610-001, 002, 003, 004
 - SP4-611-001, 002

Main Motor

1. Rear cover (📄 p.152)

2. Main motor [A] (🔩 x 3, 🛠️ x 1)

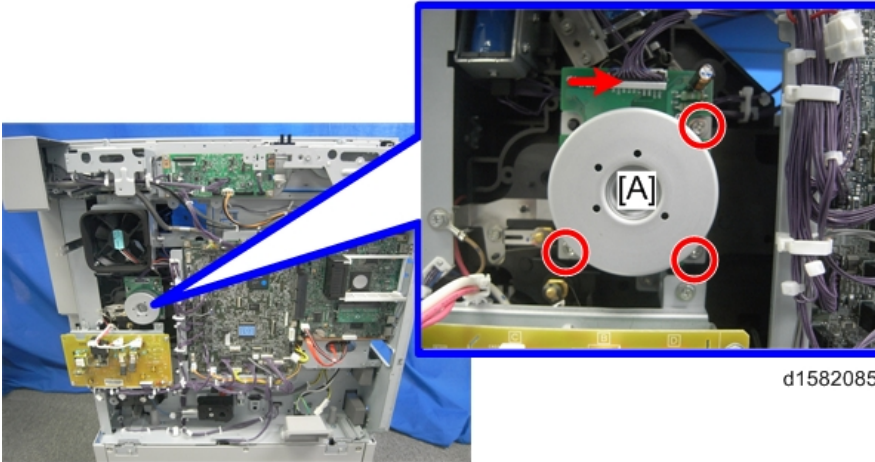

4

Rear Exhaust Fan (Duplex Models Only)

1. Platen cover, or ARDF (if installed)
2. Rear cover (🔩 p.152)
3. Top rear cover (🔩 p.153)
4. Bracket [A] (🔩 x 4)

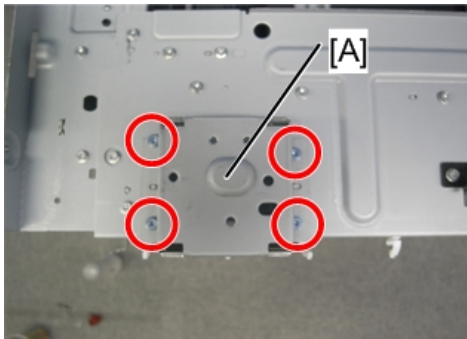

d1582079

5. Rear exhaust fan [A] (🔧 x 3)

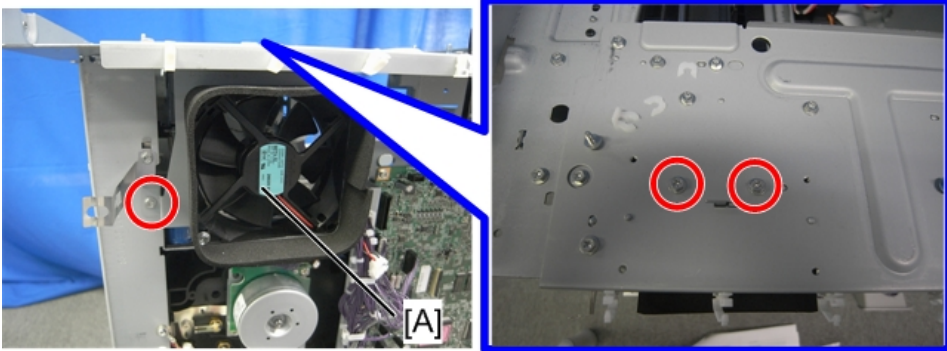

d1582080

4

★ Important

- Make sure that the arrow on the fan [A] points to the outside of the copier when you reassemble. The arrow indicates the direction of the air current.

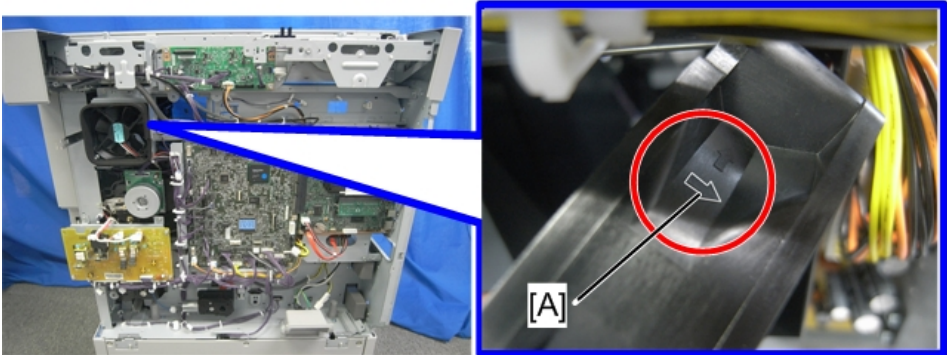

d1582086

Left Exhaust Fan

1. Rear cover (🔧 p.152)
2. Left cover (🔧 p.158)

3. Fan cover [A] (🔩 x 2)

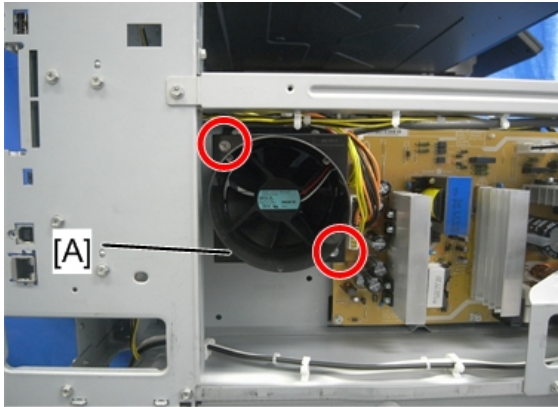

d1582087

4. Fan [A] (🌀 x 1, 📡 x 1)

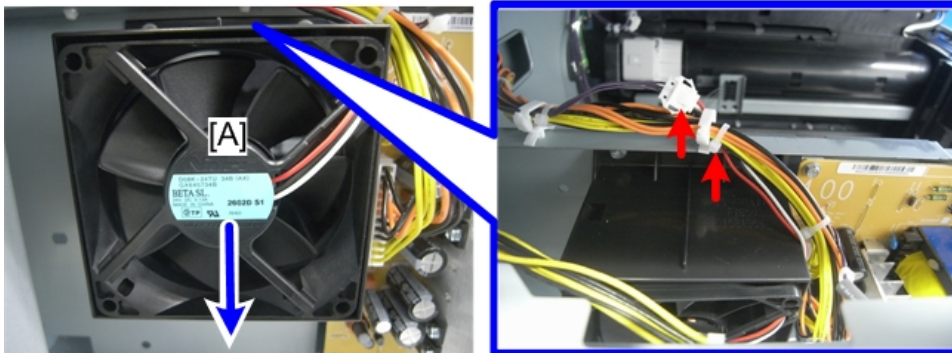

d1582089

★ Important

- Make sure that the arrow on the fan [A] points to the outside of the copier when you reassemble. The arrow indicates the direction of the air current.

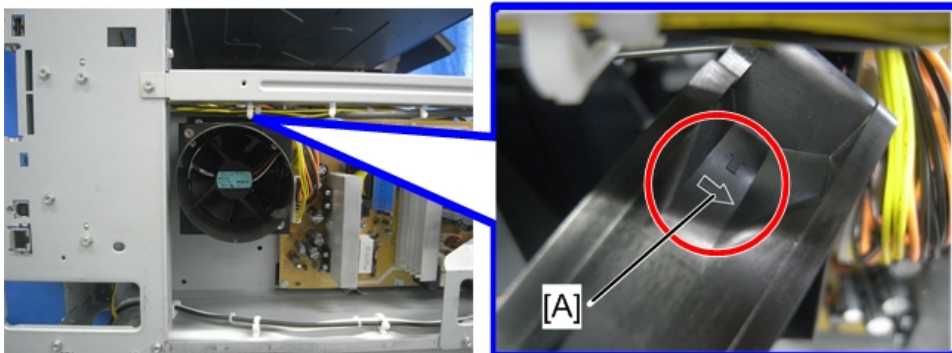

d1582087

PSU (Power Supply Unit)

1. Left cover (🔧 p.158)
2. PSU [A] (All connectors, 🔧 x 6)

RTB 36

Caution: Some parts of the PSU retain charge for a long period after disconnecting the power. See the diagrams in this RTB for details.

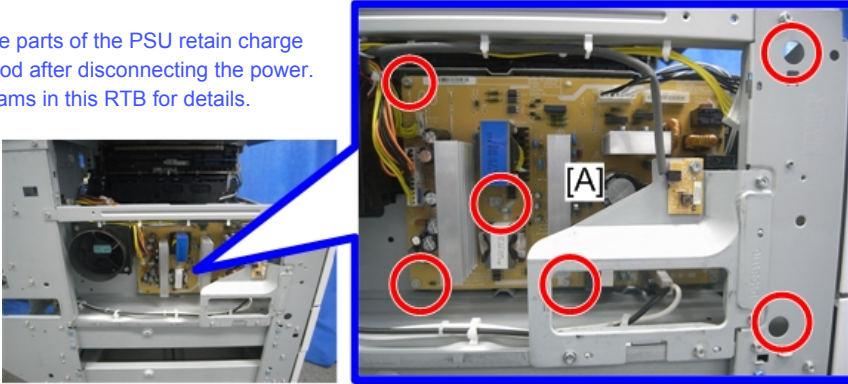

d1582090

4

Gearbox

Replacement Procedure

1. Inverter tray [A]
2. Exit rear cover (🔧 p.152 "Output Tray, Exit Cover, Exit Rear Cover")

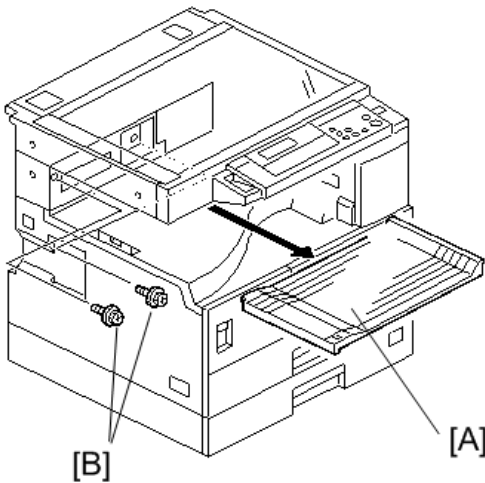

d1582098

Note

- This step releases the topmost part of the BICU bracket.

3. High-voltage power supply board (with the bracket) (🔧 p.248)
4. BICU (with the bracket) (🔧 p.248)
5. Main motor (🔧 p.250)
6. Rear exhaust fan (Duplex Models Only) (🔧 p.251)
7. Registration clutch (🔧 p.213)
8. PCU (🔧 p.200)

Note

- This step releases the gear (on the gearbox) that drives the PCU.

9. Ground plate [E] (🔧 x 2)

10. Gearbox [F] (⚙ x 5, 1 belt)

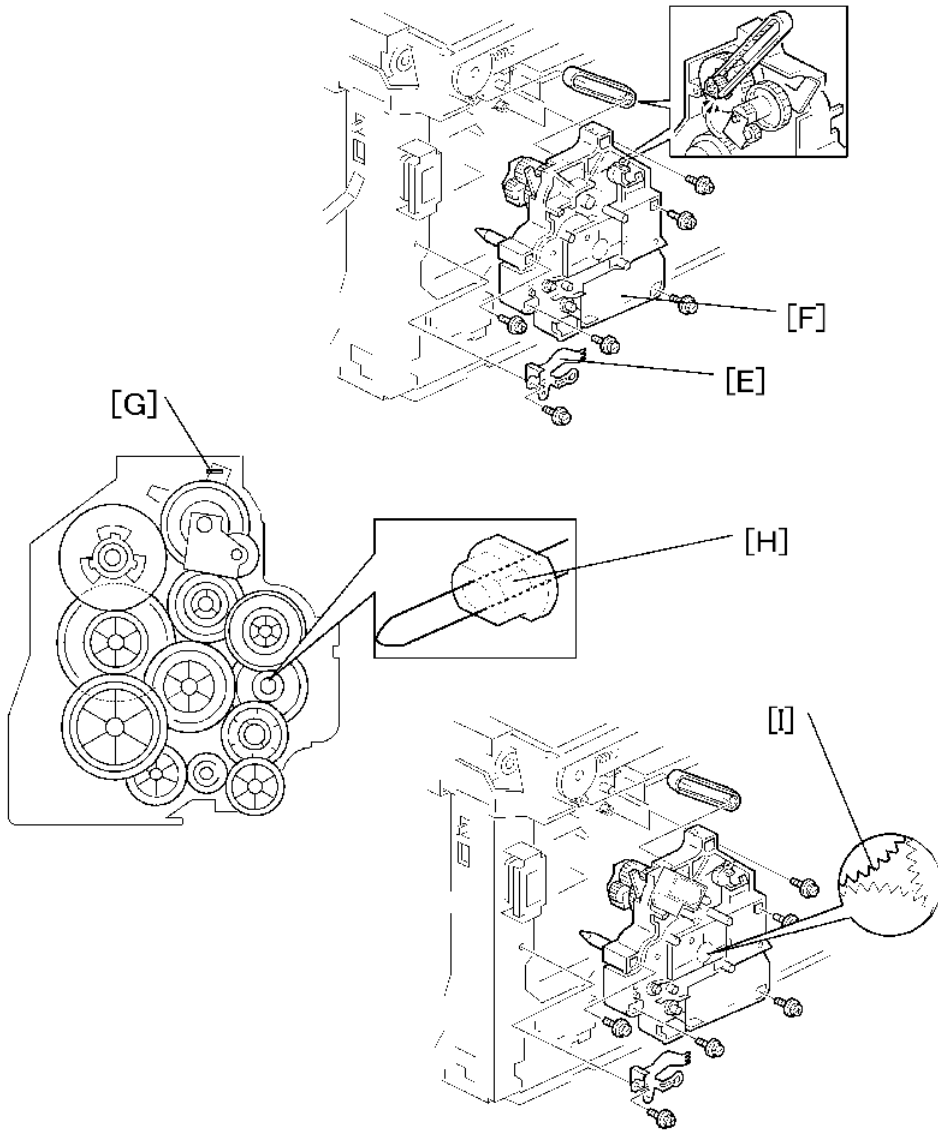

Do not change the position of the spring [G] and make sure that the bushing [H] on the PCU drive shaft is in the correct position you when you reassemble. You can adjust its position by rotating the gear [I] seen from the opening of the gearbox.

Gear Arrangement in the Gearbox

The gears are numbered 1 to 12 in the order in which they are to be installed in the gearbox. These numbers show both on the gearbox and on the front (exposed) surface of each gear. If the gears fall out, start by finding gear number 1 and installing it onto location number 1 (setting it into place so that

the side with the printed number stays visible). Then install the remaining gears (2 to 12) in the same way.

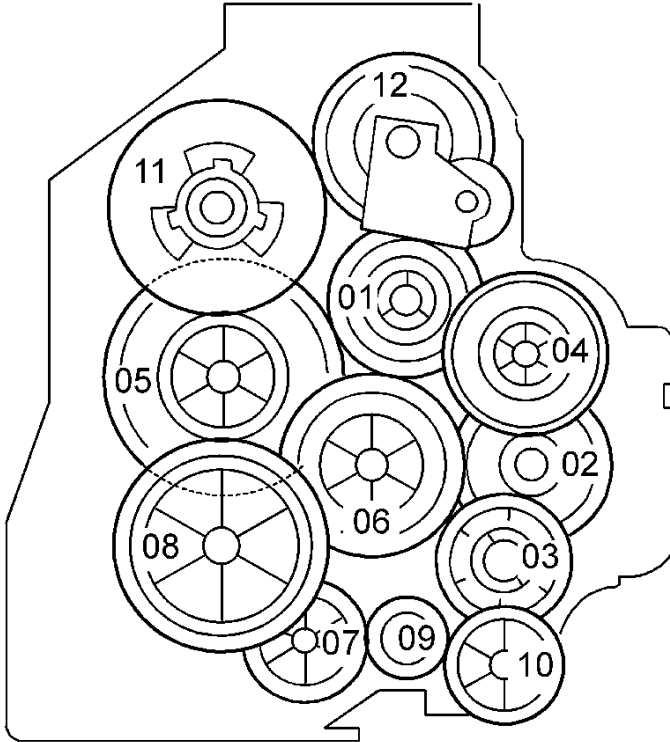

Copy Adjustments Printing/Scanning

↓ Note

- You need to perform the adjustment after you do a Memory All Clear, and after you replace or adjust any of the following parts.
 - First or second scanner
 - Lens Block
 - Scanner Motor
 - Polygonal Mirror Motor
 - Paper Tray
 - Paper Side Fence
- For detailed explanations about how to access and use the SP modes, see Section 5.

4

Printing

↓ Note

- Make sure the paper is installed correctly in each paper tray before you start these adjustments.
- Use the Trimming Area Pattern SP5-902, No. 10 (D160/D161/D170) or SP2-109, No.14 (D158/D159) to print the test pattern for the printing adjustments below.
- Set SP5-902 (D160/D161/D170) or SP2-109 (D158/D159) to 0 again after you complete these printing adjustments.

- Registration - Leading Edge/Side-to-Side -

1. Check the leading edge registration for each paper feed station, and adjust each of these registrations using SP1-001.
2. Check the side-to-side registration for each paper feed station, and adjust these registrations using SP1-001. (Adjust the trays in order: the 1st tray first, then the 2nd tray, etc.)

Tray	SP mode	Specification
Any paper tray: Plain	SP1-001-002	2 ± 1.5 mm
Any paper tray: Mid Thick	SP1-001-003	
Any paper tray: Thick	SP1-001-004	
By-pass feed: Plain	SP1-001-007	
By-pass feed: Mid Thick	SP1-001-008	
By-pass feed: Thick	SP1-001-009	
Duplex: Plain	SP1-001-013	
Duplex: Mid Thick	SP1-001-014	
Duplex: Thick	SP1-001-015	
By-pass feed	SP1-002-001	
Tray Main 1	SP1-002-002	
Tray Main 2	SP1-002-003	
Tray Bank 1	SP1-002-004	
Tray Bank 2	SP1-002-005	
Duplex	SP1-002-006	

4

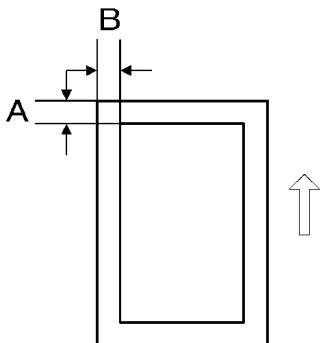

A: Leading Edge Registration

B: Side-to-side Registration

- Blank Margin -

Note

- If the leading edge or side-to-side registration cannot be adjusted to within the specification, then adjust the leading-edge blank margin or the left-side blank margin.
1. Check the trailing edge and right side edge blank margins, and adjust them using the following SP modes.

<D160/D161/D170>

	SP mode	Specification
Trailing edge	SP2-101-002	2 +2.5/-1.5 mm
Right edge	SP2-101-004	
Leading edge	SP2-101-001	2 ± 1.5 mm
Left edge	SP2-101-003	

<D158/D159>

	SP mode	Specification
Trailing edge	SP2-103-002	3.0 mm [0.0-9.0 mm]
Leading edge	SP2-103-001	
Right edge	SP2-103-004	2.0 mm [0.0-9.0 mm]
Left edge	SP2-103-003	
Duplex Trail: L Size: Plain	SP2-103-005	1.0 mm [0.0-4.0 mm]
Duplex Trail: M Size: Plain	SP2-103-006	0.8 mm [0.0-4.0 mm]
Duplex Trail: S Size: Plain	SP2-103-007	0.6 mm [0.0-4.0 mm]
Duplex Left: Plain	SP2-103-008	0.3 mm [0.0-1.5 mm]
Duplex Right: Plain	SP2-103-009	
Duplex Trail: L Size: Thick	SP2-103-010	0.8 mm [0.0-4.0 mm]
Duplex Trail: M Size: Thick	SP2-103-011	0.6 mm [0.0-4.0 mm]
Duplex Trail: S Size: Thick	SP2-103-012	0.4 mm [0.0-4.0 mm]

	SP mode	Specification
Duplex Left: Thick	SP2-103-013	0.1 mm [0.0-1.5 mm]
Duplex Right: Thick	SP2-103-014	

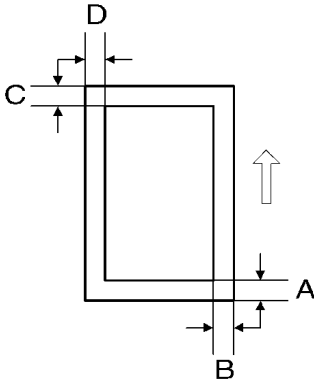

- A: Trailing Edge Blank Margin
 B: Right Edge Blank Margin
 C: Leading Edge Blank Margin
 D: Left Edge Blank Margin

- Main Scan Magnification -

1. Print the single-dot grid pattern (D160/D161/D170: SP5-902-001, No.5, D158/D159: SP2-109-001, No.7).
2. Check the magnification (the grid size should be 2.7 x 2.7 mm), and if necessary use SP 2998 to adjust it. The specification is $100 \pm 1\%$.

Scanning

↓ Note

- Before doing the following scanner adjustments, check and adjust the printing leading-edge and side-to-side registrations and the printing blank margins (as described above).
- Use an A3 test chart to perform the following adjustments.

- Registration: Platen Mode -

1. Place the test chart on the exposure glass and make a copy from one of the feed stations.
2. Check the leading edge and side-to-side registration, and adjust as necessary with the following SP modes.

	SP mode	Specification
Leading edge	SP4-010	2 ± 2.0 mm
Side-to-side	SP4-011	2 ± 2.5 mm

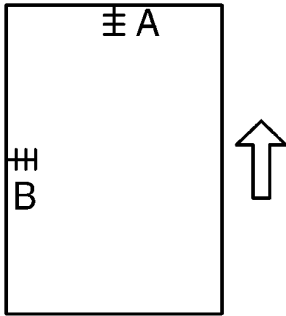

A: Leading edge registration
 B: Side-to-side registration

- Magnification -

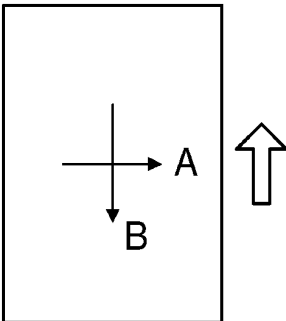

A: Main scan magnification
 B: Sub-scan magnification

- Main Scan Magnification (Only for D160/D161/D170) -

1. Place the OS-A3 test chart on the exposure glass and make a copy from one of the feed stations.
2. Check the magnification ratio. If necessary, adjust the magnification with the following SP mode.

	SP mode	Specification
Main-scan magnification	SP4-009	$\pm 1.0\%$

- Sub-Scan Magnification -

1. Place the OS-A3 test chart on the exposure glass and make a copy from one of the feed stations.

2. Check the magnification ratio. If necessary, adjust the magnification with the following SP mode.

	SP mode	Specification
Sub-scan magnification	SP4-008	± 1.0%

ARDF Image Adjustment

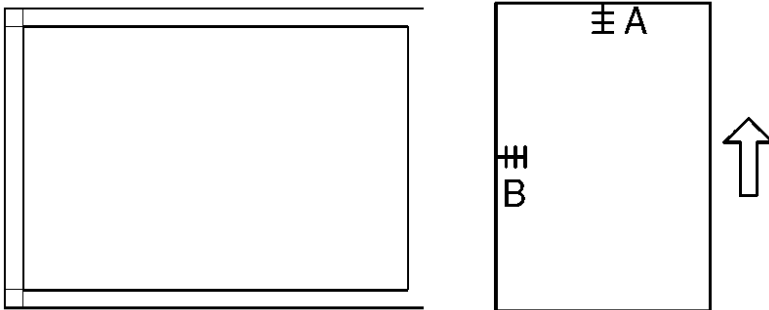

A: Leading edge registration

B: Side-to-side registration

Note

- Make a temporary test chart as shown above, using A3/11" x 17" paper.
1. Place the temporary test chart on the ARDF and make a copy from one of the feed stations.
 2. Check the registrations, and adjust as necessary with the appropriate SP modes, as follows.

	SP mode
ADF Adjustment - Side to Side Registration	SP6-006-001 (D160/D161/D170)
ADF Adjustment - Leading Registration	SP6-006-002 (D160/D161/D170)
ADF Adjustment - Magnification	SP6-006-005 (D160/D161/D170)
ADF Adjustment - Side to Side Registration: Front	SP6-006-001 (D158/D159)
ADF Adjustment - Side to Side Registration: Rear	SP6-006-002 (D158/D159)
ADF Adjustment - Leading Edge Registration	SP6-006-003 (D158/D159)
DF Magnification Adjustment	SP6-017-001 (D158/D159)

- Sub-scan Magnification -

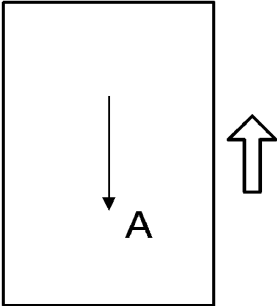

4

A: Sub-scan magnification

Note

- Make a temporary test chart as shown above, with A3/11" x 17" paper.
1. Place the temporary test chart on the ARDF and make a copy from one of the feed stations.
 2. Check the registration, and if necessary adjust it with SP6-017-001. The specification is $\pm 1.0\%$.

5. Troubleshooting

Troubleshooting Image Quality Problems

Marks (Vertical Streaks) on Prints and Copies due to Scanning Problems

Marks on prints and copies are mostly due to dirt on the DF exposure glass [A], generally caused by adhesive contaminants (such as ball point pen ink and correction fluid).

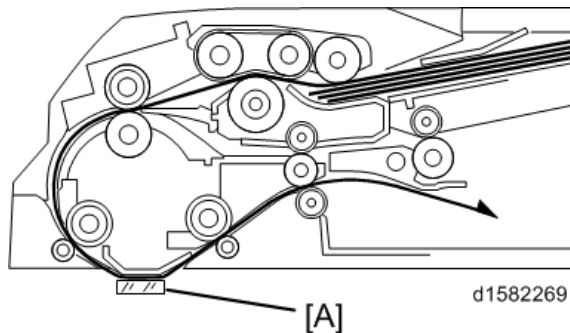

Compared to non-adhesive contaminants (such as paper fragments and eraser dust), adhesive contaminants are more likely to lead to complaints from customers because of the following:

- Vertical streaks caused by adhesive contaminants are more visible in terms of image quality.
- Unless removed by cleaning, adhesive contaminants continue to produce vertical streaks, while non-adhesive contaminants stop producing streaks after they are dislodged.
- Many adhesive contaminants are difficult to remove by cleaning.

The ARDF DF2020 (D684) features a system (non-contact scanning) to reduce vertical streaks caused by adhesive contaminants.

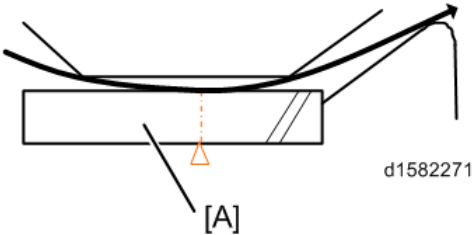
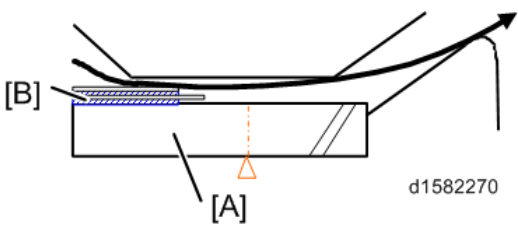
Contact scanning: Other ADFs/ARDFs	Non-contact scanning: ARDF DF2020 (D684)
 <p>In contact scanning, the whole of the original comes into contact with the DF exposure glass [A] so that non-adhesive contaminants can be removed.</p>	 <p>By means of the Mylar sheet [B], originals are kept slightly above the DF exposure glass [A], preventing adhesive contaminants from adhering to the glass.</p>

5

The ARDF DF2020 (D684) can be converted from non-contact scanning to contact scanning for users who wish to reduce vertical streaks caused by non-adhesive contaminants.

Converting the ARDF DF2020 (D684) to Contact Scanning

★ Important

- Unplug the machine power cord before starting the following procedure.

1. ARDF front cover [A] (🔧 x 1)

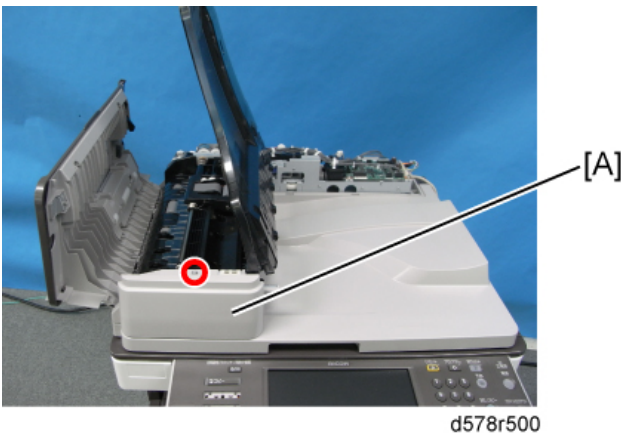

2. Scanning guide plate [B] (🔧 [A] x 1)

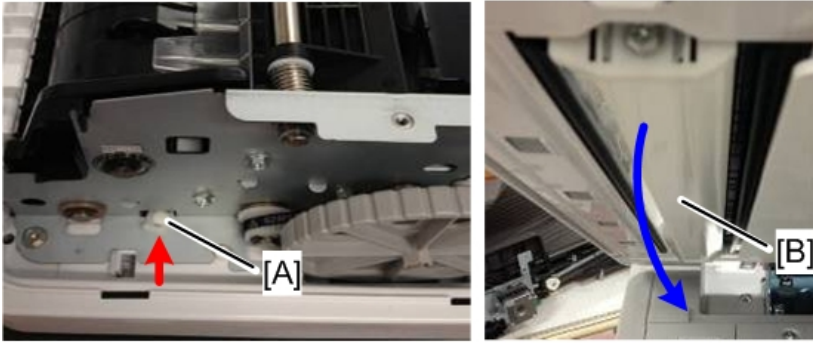

d1582263

3. Remove the plastic guides [A] on the sides of the scanning guide plate. (⚒ x 1)

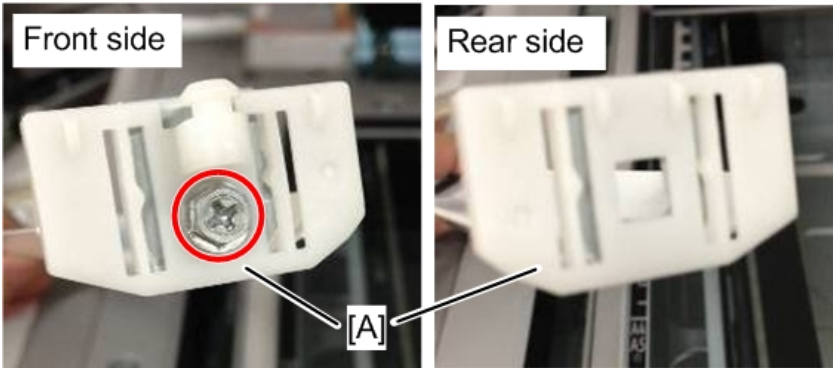

w_d1582264

4. Attach the guides for contact scanning. Each guide has a hole [B].

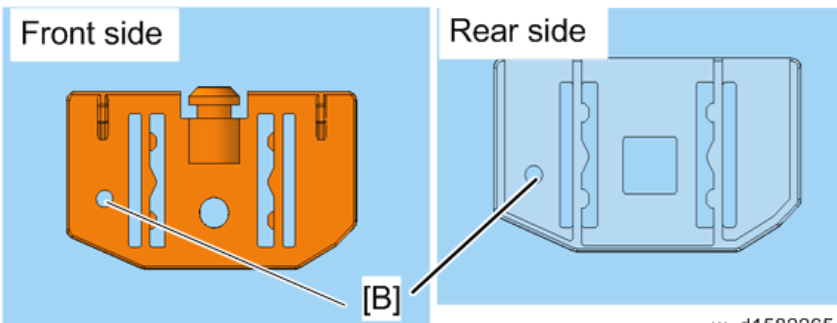

w_d1582265

5. Mount the scanning guide plate, taking care not to damage the Mylar sheet [A].

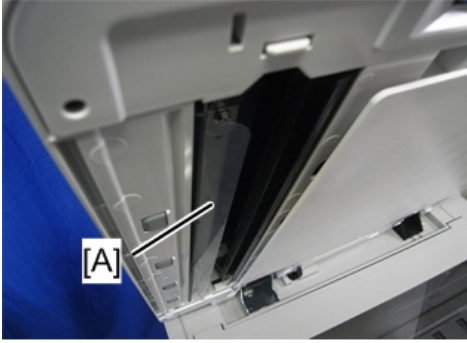

d1582266

6. Peel off the mylar from the DF exposure glass with your hands.

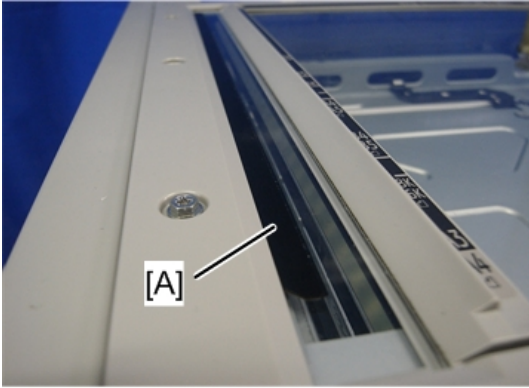

d1582267

7. Use alcohol to clean the DF exposure glass [A].

Note

- To avoid paper jams, make sure adhesive is completely removed.

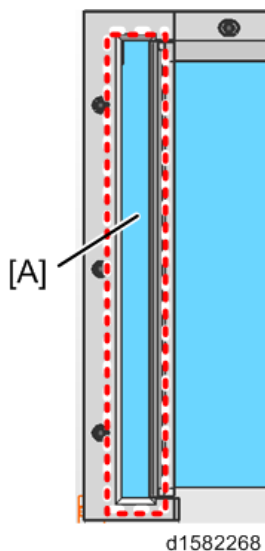

8. Turn the main switch on.
9. Start the SP mode.
10. Select SP4-688-001 (DF Density Adjustment) and change the setting to "101%" (For the non-contact method, select "106%").

Service Call Conditions

Summary

There are four levels of service call conditions.

Level	Definition	Reset Procedure
A	To prevent damage to the machine, the main machine cannot be operated until the SC has been reset by a service representative (see the note below).	Enter SP mode, and then turn the main power switch off and on.
B	If the SC was caused by incorrect sensor detection, the SC can be reset by turning the main power switch off and on.	Turn the main power switch off and on.
C	The main machine can be operated as usual, excluding the unit related to the service call.	Turn the main power switch off and on.
D	The SC history is updated. The machine can be operated as usual.	The SC will not be displayed. Only the SC history is updated.

↓ Note

- If the problem concerns electrical circuit boards, first disconnect then reconnect the connectors before replacing the PCBs.
- If the problem concerns a motor lock, first check the mechanical load before replacing motors or sensors.

SC Code Descriptions

SC1xx: Scanning

No. Definition		Symptom	Possible Cause
101 -01	B	Exposure Lamp Error (D158/D159)	
		The standard white level was not detected properly when scanning the white plate.	<ul style="list-style-type: none"> • Exposure lamp • Exposure lamp stabilizer • Exposure lamp connector • Dirty scanner mirror or scanner mirror out of position • SBU board • SBU connector • Lens block out of position
101 -02	B	Exposure Lamp Error (LED light adjustment) (D158/D159)	
		LED error flag is on	<ul style="list-style-type: none"> • Defective LED • Defective LED driver • Defective harness
101	B	Exposure Lamp Error (D160/D161/D170)	
		The standard white level was not detected properly when scanning the white plate.	<ul style="list-style-type: none"> • Defective LED • Defective harness • Dirty scanner mirror or scanner mirror out of position
102	B	LED light adjustment error (D158/D159)	
		Reading white plate level is over prescribed rate.	<ul style="list-style-type: none"> • Defective LED • Defective LED driver • Defective SBU • Defective BICU • Defective harness

No. Definition		Symptom	Possible Cause
120	B	Scanner home position error 1	
		The scanner home position sensor does not detect the off condition during initialization or copying.	<ul style="list-style-type: none"> • Scanner home position sensor • Scanner drive motor • Scanner home position sensor connector • Scanner drive motor connector • BICU board
121	B	Scanner home position error 2	
		The scanner home position sensor does not detect the on condition during initialization or copying.	<ul style="list-style-type: none"> • Scanner home position sensor • Scanner drive motor • Scanner home position sensor connector • Scanner drive motor connector • BICU board
141	B	Black level correction error	
		Black level is over prescribed rate.	<ul style="list-style-type: none"> • Defective SBU • Defective BICU • Defective harness
142	B	White level correction error	
		White level is over prescribed rate.	<ul style="list-style-type: none"> • Defective SBU • Defective LED • Defective LED driver • Defective BICU • Defective harness • Scanner unit condensation • Dirty scanner mirror or lens • Dirty platen sheet

No. Definition		Symptom	Possible Cause
144	B	Communication Error between BICU and SBU	
		The BICU board cannot detect the SBU connect signal.	<ul style="list-style-type: none"> • The flat cable between the BICU board and the SBU has a poor connection • The flat cable between the BICU board and the SBU is damaged • BICU board • SBU
161-01	B	IPU (BICU) error (LSYNC error) (D158/D159)	
		Error was detected in the result of the BICU self-check at startup.	<ul style="list-style-type: none"> • Defective BICU • Bad cable connection between the SBU and the BICU.
161-02	B	IPU (BICU) error (RI response error) (D158/D159)	
		Error was detected on access to the RI.	<ul style="list-style-type: none"> • Defective BICU
165	B	Unauthorized copy protection Failed (D158/D159)	
		Detected the wrong type of copy data protection unit, or no unit was found when copy protection was turned on, or a problem was detected with the unit at startup.	<ul style="list-style-type: none"> • Copy data protection unit not attached firmly. • Defective copy data protection unit
195	B	Serial number mismatch	
		Checking if the serial number matches.	<ul style="list-style-type: none"> • Serial numbers (11 digits) do not match.

SC2xx: Exposure (D158/D159)

No. Definition		Symptom	Possible Cause
202	C	Polygon motor error : ON timeout	
		When the polygon motor is rotating.	<ul style="list-style-type: none"> • Defective or disconnected harness to polygon motor • Defective polygon motor • The polygon motor drive pulse is not released correctly.
203	C	Polygon motor error : OFF timeout	
		When the polygon motor is OFF.	<ul style="list-style-type: none"> • Defective or disconnected harness to polygon motor • Defective polygon motor • The polygon motor drive pulse is not released correctly.
204	C	Polygon motor error : PMRDY_N signal error	
		When the polygon motor is rotating.	<ul style="list-style-type: none"> • Defective or disconnected harness to polygon motor • Defective polygon motor
220	C	Laser synchronizing detection error	
		When the laser synchronizing detection is ON	<ul style="list-style-type: none"> • Disconnected or defective I/F harness to laser unit. • The laser fails to reach the photo detector. • Defective laser unit • Defective BICU
230	C	FGATE ON error	
		When processing the image	<ul style="list-style-type: none"> • Disconnected or defective connector between BICU and controller board • Disconnected or defective harness between BICU and laser unit

No. Definition		Symptom	Possible Cause
231	C	FGATE OFF error	
		When processing the image	<ul style="list-style-type: none"> Defective BICU Disconnected or defective connector between BICU and controller board
240	D	LD error	
		The LD driver's error signal is detected after LD initialization.	<ul style="list-style-type: none"> Worn-out LD Disconnected or broken harness of the LD Defective LD drive component Defective laser unit
270	B	GAVD communication error	
		Energy saver mode was turned off during main power is ON.	<ul style="list-style-type: none"> Defective BICU

SC3xx: Image Processing

No. Definition		Symptom	Possible Cause
302	B	Charge roller current leak	
		A current leak signal for the charge roller is detected.	<ul style="list-style-type: none"> Charge roller damaged High voltage supply board Poor connection of the PCU
320	B	Polygonal mirror motor error	
		The polygon mirror motor does not reach operating speed within 10 seconds after the motor ON signal is sent, or does not turn on within one of the 200 ms check intervals during operation.	<ul style="list-style-type: none"> Polygon mirror motor Poor connection between the polygonal mirror motor driver and the BICU board Damaged cable between BICU and polygonal mirror motor driver BICU board

No. Definition		Symptom	Possible Cause
321	C	No laser writing signal (F-GATE) error	
		The laser-writing signal (F-GATE) fails to turn Low after the laser crosses 5 mm on the drum surface from the laser writing start position.	<ul style="list-style-type: none"> • BICU board • The fax controller or printer controller has a poor connection • Fax controller or printer controller
322	B	Laser synchronization error	
		The main scan synchronization detector board cannot detect the laser synchronization signal for more than 5 consecutive 100 ms intervals.	<ul style="list-style-type: none"> • Poor connection between the laser unit and the BICU board • Damaged cable between BICU and laser unit • Laser unit • BICU board
350	B	ID sensor error (In-process)	
		Vsg adjustment error Vsp error Vsg error Vsg-Vsp error TD sensor error	<ul style="list-style-type: none"> • Dirt on the ID sensor • ID sensor not installed at the correct angle. • Defective ID sensor • Defective PCU • Development roller is not rotating
351	B	ID sensor : Vsg measurement error (In-process) (D158/D159)	
		When the ID sensor detects that Vsg is 5 V and LED drive current is minimum (PWM=0).	<ul style="list-style-type: none"> • Defective ID sensor • Disconnection of the harness to the ID sensor • Bad electrical contact of the ID sensor connector • Defective BCU • Defective laser unit • Defective developer density • Defective high-voltage power pack • Dirty ID sensor

No. Definition	Symptom	Possible Cause
353		ID sensor : Auto adjustment value error (In-process) (D158/D159)
	B When the ID sensor is adjusting Vsg automatically.	<ul style="list-style-type: none"> • Defective ID sensor • Disconnection of the harness to the ID sensor • Bad electrical contact of the ID sensor connector • Defective BCU • Defective laser unit • Defective developer density • Defective high-voltage power pack • Dirty ID sensor
354		ID sensor : Auto adjustment time-out (In-process) (D158/D159)
	B When the ID sensor is adjusting Vsg automatically.	<ul style="list-style-type: none"> • Defective ID sensor • Disconnection of the harness to the ID sensor • Bad electrical contact of the ID sensor connector • Defective BCU • Defective laser unit • Defective developer density • Defective high-voltage power pack • Dirty ID sensor

No. Definition		Symptom	Possible Cause
355	D	P sensor error (D158/D159)	
		SC350~354 happen during normal operation. This error isn't displayed on the panel but is left in the error log.	<ul style="list-style-type: none"> • Defective ID sensor • Disconnection of the harness to the ID sensor • Bad electrical contact of the ID sensor connector • Defective BCU • Defective laser unit • Defective developer density • Defective high-voltage power pack • Dirty ID sensor
389	D	TD sensor error (D158/D159)	
		Detected the following value TD sensor output value < 0.2V TD sensor output value > 4.0V 10 times in series.	<ul style="list-style-type: none"> • Defective TD sensor • Bad contact of the connector to the TD sensor
390	B	TD sensor error	
		The TD sensor outputs less than 0.2 V or more than 4.0 V 10 times consecutively during copying.	<ul style="list-style-type: none"> • TD sensor abnormal • Poor connection of the PCU
391	B	Development bias leak	
		A development bias leak signal is detected.	<ul style="list-style-type: none"> • Poor connection of the PCU • High voltage supply board

No. Definition		Symptom	Possible Cause
392	B	TD sensor initial setting error	
		TD sensor initial setting is not performed correctly.	<ul style="list-style-type: none"> • ID sensor • No developer • Drum does not turn • Development roller does not turn • Poor connection of the PCU • The voltage is not applied to charge roller

SC4xx: Image Processing

5

No. Definition		Symptom	Possible Cause
440	B	Image transfer positive electrode current error	
		An interrupt checks the status of the power pack every 20 ms. This SC is issued if the BCU detects a short in the power pack 10 times consecutively.	<ul style="list-style-type: none"> • Defective image transfer roller • Defective high voltage supply unit • Connection error • Image transfer unit is not installed correctly.
460	B	Separation power pack output error (D158/D159)	
		An interrupt checks the status of the power pack every 20 ms. This SC is issued if the BCU detects a short in the power pack 10 times at D (ac).	<ul style="list-style-type: none"> • High-voltage leak • Loose connection • Broken harness • Defective-high voltage supply unit
490	B	Toner transport motor error (D158/D159)	
		When the toner transport motor is ON	<ul style="list-style-type: none"> • Motor lock • Defective motor drive

SC5xx: Paper Feed and Fusing

No. Definition		Symptom	Possible Cause
501	C	Tray 1 lift motor malfunction (Optional paper tray units)	
		The paper lift sensor fails to activate twice continuously after the tray lift motor has been on for 12 seconds.	<ul style="list-style-type: none"> • Paper lift sensor • Tray lift motor • Too much load on the drive mechanism • Poor tray lift motor connection
502	C	Tray 2 lift motor malfunction (Optional paper tray units)	
		The paper lift sensor fails to activate twice continuously after the tray lift motor has been on for 12 seconds.	<ul style="list-style-type: none"> • Paper lift sensor • Tray lift motor • Too much load on the drive mechanism • Poor tray lift motor connection
503 -01 -11	C	Paper bank 1 error (Paper Feed Unit or LCT) (Paper lift error) (D158/D159)	
		The paper lift sensor fails to activate after the tray lift motor has been on for 18 seconds	<ul style="list-style-type: none"> • Paper lift sensor • Tray lift motor • Poor tray lift motor connection • Broken harness • Defective bank controller board
503 -02 -12	C	Paper bank 1 error (Paper Feed Unit or LCT) (Upper limit error) (D158/D159)	
		The paper lift sensor fails to activate three times continuously right after the tray lift motor has been turned on.	<ul style="list-style-type: none"> • Paper lift sensor • Broken harness • Defective bank controller board
503	C	Tray 3 error (D160/D161/D170)	
		The paper lift sensor fails to activate three times continuously after the tray lift motor has been on for 18 seconds.	<ul style="list-style-type: none"> • Paper lift sensor • Tray lift motor • Broken harness • Defective bank controller board

No. Definition		Symptom	Possible Cause
504 -01 -11	C	Paper bank 2 error (Paper Feed Unit or LCT) (Paper lift error) (D158/D159)	
		The paper lift sensor fails to activate after the tray lift motor has been on for 18 seconds.	<ul style="list-style-type: none"> • Paper lift sensor • Tray lift motor • Broken harness • Defective bank controller board
504 -02 -12	C	Paper bank 2 error (Paper Feed Unit or LCT) (Upper limit error) (D158/D159)	
		The paper lift sensor fails to activate right after the tray lift motor has been turned on.	<ul style="list-style-type: none"> • Paper lift sensor • Broken harness • Defective bank controller board
504	C	Tray 4 error (D160/D161/D170)	
		The paper lift sensor fails to activate three times continuously after the tray lift motor has been on for 18 seconds.	<ul style="list-style-type: none"> • Paper lift sensor • Tray lift motor • Broken harness • Defective bank controller board
508	C	By-pass bottom plate error	
		The signal from the by-pass tray HP sensor does not change for 1.0 second after the by-pass motor has rotated counterclockwise. If this condition occurs three consecutive times, the SC is generated.	<ul style="list-style-type: none"> • Disconnect or defective harness of the by-pass motor • Defective or disconnected connection for the by-pass motor.
520	C	Registration motor error	
		When the registration motor is rotating	<ul style="list-style-type: none"> • Motor lock • Defective motor driver

No. Definition		Symptom	Possible Cause
521 -01 -11	C	Bank transport motor error (D158/D159)	<ul style="list-style-type: none"> • Defective bank transport motor • Loose connection • Disconnected or broken harness • Defective bank controller board
		An error code is issued from the paper bank unit.	
521	C	Bank transport motor error (D160/D161/D170)	<ul style="list-style-type: none"> • Defective bank transport motor • Loose connection • Defective bank controller board
		The error code occurs when the optional paper tray unit (D698) is installed.	
530	B	Fusing fan error (D158/D159)	
531	B	QSU fan error (D158/D159)	
532	B	CTL fan error (D158/D159)	
		Lock signal is not issued for more than 50 consecutive 100 ms intervals, during fan is rotating.	<ul style="list-style-type: none"> • Motor overload • Loose connection
541	A	Fusing thermistor open (center)	<ul style="list-style-type: none"> • Fusing thermistor defective or out of position • Loose connectors
		The fusing temperature is below 0°C for 5 seconds (detected by the thermistor).	
542 -01	A	Fusing reload failed (center) (D158/D159)	<ul style="list-style-type: none"> • Fusing thermistor defective or out of position • Power supply board
		The fusing temperature rises less than 4 degrees in 2 seconds, and this continues 5 times consecutively.	

No. Definition		Symptom	Possible Cause
542 -03	A	Fusing reload failed (center) (D158/D159)	
		The fusing temperature does not reach the target within 28 seconds after the fusing lamp controller is activated.	<ul style="list-style-type: none"> • Broken fusing lamp cables
542	A	Fusing reload failed (center) (D160/D161/D170)	
		NOT reaching the reload temperature in 20 ms after starting fusing lamp control.	<ul style="list-style-type: none"> • Defective thermistor • Disconnected fusing lamp
543	A	Fusing overheat error (center)	
		The fusing temperature is over 230°C for 1 second (detected by the thermistor).	<ul style="list-style-type: none"> • Fusing thermistor • Power supply board
544	A	Fusing overheat error (center) 2	
		The fusing temperature is over 250°C for more than a certain time (zero cross signal x 3). (detected by the fusing temperature monitor circuit).	<ul style="list-style-type: none"> • Fusing thermistor • Power supply board
545	A	Fusing lamp overheat error (center)	
		After the fusing temperature reaches the target temperature, the fusing lamp does not turn off for 29 consecutive seconds.	<ul style="list-style-type: none"> • Fusing thermistor defective or out of position • Power supply board • Broken fusing lamp cables
547 -01	B	Zero cross signal malfunction(D158/D159)	
		Zero cross signals are detected three consecutive times at 50 ms intervals. This error is detected before the fusing relay is turned on after turning on the main power or closing all the doors.	<ul style="list-style-type: none"> • Defective fusing relay • Defective fusing relay circuit • Defective PSU • Power supply board

No. Definition		Symptom	Possible Cause
547 -02	B	Zero cross signal malfunction (D158/D159)	
		The zero cross signal is not detected for 3 seconds even though the fusing relay is on after turning on the main power or closing all the doors.	<ul style="list-style-type: none"> • Defective fusing relay • Defective fusing relay circuit • Defective PSU • Power supply board
547 -03	B	Zero cross signal malfunction(D158/D159)	
		A detection error occurs twice or more in 11 frequency detections. This error is defined when the detected zero cross signal is less than 45.	<ul style="list-style-type: none"> • Defective fusing relay • Defective fusing relay circuit • Defective PSU • Power supply board
547	B	Zero cross signal malfunction (D160/D161/D170)	
		Detecting low-frequency wave	<ul style="list-style-type: none"> • Defective PSU • Defective BICU
551	A	Fusing thermistor open (rear)	
		The fusing temperature is below 0°C for 5 seconds (detected by the thermistor).	<ul style="list-style-type: none"> • Fusing thermistor defective or out of position • Loose connectors
552 -01	A	Fusing temperature warm-up error (rear) (D158/D159)	
		The fusing temperature rises less than 4 degrees in 2 seconds, and this continues 5 times consecutively.	<ul style="list-style-type: none"> • Fusing thermistor defective or out of position • Power supply board
552 -03	A	Fusing temperature warm-up error (rear) (D158/D159)	
		The fusing temperature does not reach the target with in 28 seconds after the fusing lamp controller is activated.	<ul style="list-style-type: none"> • Broken fusing lamp cables

No. Definition		Symptom	Possible Cause
552	A	Fusing reload failed (rear) (D160/D161/D170)	
		NOT reaching the reload temperature in 20 ms after starting fusing lamp control.	<ul style="list-style-type: none"> • Defective thermistor • Disconnection of fusing lamp
553	A	Fusing overheat error (rear)	
		The fusing temperature is over 230°C for 1 second (detected by the thermistor).	<ul style="list-style-type: none"> • Fusing thermistor • Power supply board
554	A	Heating roller fusing lamp overheat 2 (hardware error) (D158/D159)	
		-	<ul style="list-style-type: none"> • The triac has shorted out. • Defective BICU • Defective fusing control system
555	A	Fusing lamp overheat error (rear)	
		After the fusing temperature reaches the target temperature, the fusing lamp does not turn off for 20 consecutive seconds.	<ul style="list-style-type: none"> • Fusing thermistor defective or out of position • Power supply board
557	D	Zero cross frequency error (D158/D159)	
		The detection error occurs 10 times or more in 11 frequency detections. This error is defined when the detected zero cross signal is more than 66.	<ul style="list-style-type: none"> • Caused by noise
559	A	Jam error detected 3 times in succession	
		<p>The exit sensor and the duplex sensor detect a paper jam 3 times in succession</p> <p>This condition can occur when SP1-159-001 is set to 'on'. The default is 'off'.</p>	<ul style="list-style-type: none"> • Paper jams can occur for the following reasons. • Dampness • Paper curl • Incorrect paper setting in the paper tray • Stripper pawls coming apart

No. Definition		Symptom	Possible Cause
590	B	Left exhaust fan motor error (D160/D161/D170)	
		The CPU detects an exhaust fan lock signal for more than 5 seconds.	<ul style="list-style-type: none"> • Loose connection of the exhaust fan motor • Too much load on the motor drive
591	B	Rear exhaust fan motor error (D160/D161/D170)	
		The CPU detects an exhaust fan lock signal for more than 5 seconds.	<ul style="list-style-type: none"> • Loose connection of the exhaust fan motor • Too much load on the motor drive

5

SC6xx: Device Communication

No. Definition		Symptom	Possible Cause
620	B	Communication error between BICU and ADF	
		<p>The BICU does not receive a response from the ARDF main board for 4 seconds or more.</p> <p>The BICU receives a break signal from the ARDF main board.</p>	<ul style="list-style-type: none"> • Poor connection between the BICU and ARDF main board (DF connector) • ARDF main board • BICU defective
621	B	ADF connection error (D160/D161/D170)	
		<p>An incorrect ARDF is detected.</p> <p>An ARDF (including the correct ARDF) is installed while the copier is in the energy saver mode.</p>	<ul style="list-style-type: none"> • ARDF incorrect • The connector of the ARDF is installed while the machine is in the energy saver mode.

No. Definition		Symptom	Possible Cause
622	B	Paper Bank communication error	
		An error occurs during line connection. A communication error report is received from the UART.	<ul style="list-style-type: none"> The paper bank's control board is faulty. Defective BCU/IOB The paper bank's connection is faulty.
632	B	Accounting error 1	
		An error is detected during the communication with the MF accounting device.	<ul style="list-style-type: none"> Accounting device Loose connection
634	C	Accounting RAM error	
		An error is detected in the RAM that saves the information on the MF accounting.	<ul style="list-style-type: none"> Accounting device
635	C	Accounting RAM error	
		An error is detected in the RAM that saves the information on the MF accounting.	<ul style="list-style-type: none"> Accounting device
669	B	EEPROM communication error – ID error (D158/D159)	
-01	B	EEPROM communication error – Channel error (D158/D159)	
-02	B	EEPROM communication error – Device error (D158/D159)	
-03	B	EEPROM communication error – Communication failed error (D158/D159)	
-04	B	EEPROM communication error – Communication suspended error (D158/D159)	
-05	B	EEPROM communication error – Timeout error (D158/D159)	
-06	B	EEPROM communication error – Communication suspended error (D158/D159)	
-07	B	EEPROM communication error – Buffer full error (D158/D159)	

No. Definition		Symptom	Possible Cause
-08	B	EEPROM communication error – No error code (D158/D159)	
-09	B	EEPROM communication error – ID error (D158/D159)	
-10	B	EEPROM communication error – No error code (D158/D159)	
-11	B	EEPROM communication error – ID error (D158/D159)	
-12	B	EEPROM communication error – Channel error (D158/D159)	
-13	B	EEPROM communication error – Device error(D158/D159)	
-14	B	EEPROM communication error – Communication failed error (D158/D159)	
-15	B	EEPROM communication error – Timeout error (D158/D159)	
-16	B	EEPROM communication error – Communication suspended error (D158/D159)	
-17	B	EEPROM communication error – Buffer full error (D158/D159)	
-18	B	EEPROM communication error – No error code (D158/D159)	
-19	B	EEPROM communication error – ID error (D158/D159)	
-20	B	EEPROM communication error – Channel error (D158/D159)	
-21	B	EEPROM communication error – Device error (D158/D159)	
-22	B	EEPROM communication error – Communication failed error (D158/D159)	
-23	B	EEPROM communication error – Timeout error (D158/D159)	
-24	B	EEPROM communication error – Communication suspended error (D158/D159)	
-25	B	EEPROM communication error – Buffer full error (D158/D159)	
-26	B	EEPROM communication error – No error code (D158/D159)	
		Retry of EEPROM communication fails three times after the machine has detected the EEPROM error.	<ul style="list-style-type: none"> • Caused by noise • Defective EEPROM

No. Definition		Symptom	Possible Cause
681 -01	B	Device ID is not identified. (D158/D159)	
-06	B	Channel error (D158/D159)	
-11	B	Device error (No ID chip) (D158/D159)	
-16	B	Communication failed (D158/D159)	
-21	B	Timeout error (D158/D159)	
-26	B	Device detection suspended (D158/D159)	
-31	B	The requested buffer is full (D158/D159)	
-36	B	No error code (D158/D159)	
		Retry of ID tag communication fails three times after the machine has detected the ID tag error.	<ul style="list-style-type: none"> • Caused by noise
687	B	Memory address command error (D158/D159)	
		From among the I/F commands with the controller, the image transfer available report (for each command) cannot be received.	<ul style="list-style-type: none"> • Caused by noise • Defective controller board
692	C	Controller board communication abnormal (D160/D161/D170)	
		Communication error between the printer part of the controller board and BICU.	<ul style="list-style-type: none"> • The connector is abnormal between the controller board and the BICU board.
694	C	Controller board communication abnormal (D160/D161/D170)	
		Communication error between the scanner part of the controller board and BICU.	<ul style="list-style-type: none"> • The connector is abnormal between the controller board and the BICU board.

SC7xx: Peripherals

No. Definition		Symptom	Possible Cause
701 -03	B	Paper feed motor driver error (ARDF) (D158/D159)	
-08	B	Paper exit motor driver error (ARDF) (D158/D159)	
		Error signal from the motor driver	<ul style="list-style-type: none"> • Loose connection • Defective encoder • Motor overload • Worn-out motor
702 -01	B	Protected element block error 1 (ARDF) (D158/D159)	
-02	B	Protected element block error 2 (ARDF) (D158/D159)	
-03	B	Protected element block error 3 (ARDF) (D158/D159)	
		Protected element block is detected.	<ul style="list-style-type: none"> • Defective motor • Defective solenoid • Harness shorted
		ADF gate abnormal 1	
760	B	The ARDF Gate signal line between the ARDF main board and the BICU is disconnected.	<ul style="list-style-type: none"> • ARDF main board • Input/output board • Poor connection (ARDF Gate line) between the ARDF main board and the BICU.

SC9xx: Miscellaneous

No. Definition		Symptom	Possible Cause
901	B	Mechanical total counter	
		The mechanical total counter does not work properly.	<ul style="list-style-type: none"> • Defective total counter • Loose connection • Defective IOB
903	B	Engine total counter error (D160/D161/D170)	
		The checksum of the total counter is not correct.	<ul style="list-style-type: none"> • NVRAM on the BICU
928	B	Memory error (D160/D161/D170)	
		The machine detects a discrepancy in the write/read data during its write/read test (done at power off/on and at recovery from low power or night/off mode).	<ul style="list-style-type: none"> • BICU • Poor connection between BICU and memory
929	B	IMAC error (hardware) (D160/D161/D170)	
		Error register for IMAC is on, while IMAC is operating. Mechanical problem (e.g. interlock does not turned off when right door is open and .bypass tray is used at the same time.)	<ul style="list-style-type: none"> • Defective BICU • Defective interlock switch
981	B	NV-RAM error (D160/D161/D170)	
		If the machine fails to read the specific value written onto the NV-RAM on program startup, an SC code appears.	<ul style="list-style-type: none"> • Defective NV-RAM • NV-RAM is not installed

No. Definition		Symptom	Possible Cause
982	B	Localization error (D160/D161/D170)	
		The localization settings in the nonvolatile ROM and RAM are different (SP5807).	<ul style="list-style-type: none"> • First machine start after the NVRAM is replaced. • Incorrect localization setting • NVRAM
995	B	Machine information error	
		Checking if the serial number matches.	<ul style="list-style-type: none"> • Serial numbers (11 digits) do not match.

Electrical Component Defects

Sensors

Component	CN	Condition	Symptom
Registration	123-6 (BICU)	Open	The Paper Jam message will appear whenever a copy is made (paper has not reached the sensor).
		Shorted	The Paper Jam message appears even if there is no paper at the sensor.
Relay 1	123-9 (BICU)	Open	The Paper Jam message will appear whenever a copy is made except for 1st and by-pass tray feeding.
		Shorted	The Paper Jam message appears even if there is no paper at the sensor.
Paper End 1	114-2 (BICU)	Open	The Paper End indicator lights when the 1st paper tray is selected, even if there is paper in the tray.
		Shorted	The Paper End indicator does not light when the 1st paper tray is selected, even if there is no paper in the tray. The Paper Jam message will appear whenever a copy is made from the 1st paper tray.
Vertical Transport	110-2 (BICU)	Open	The Paper Jam message will appear whenever a copy is made from an optional paper tray unit.
		Shorted	The Paper Jam message appears even if there is no paper at the sensor.

Component	CN	Condition	Symptom
Paper End 2	113-7 (BICU)	Open	The Paper End indicator lights when the 2nd paper tray is selected, even if there is paper in the tray.
		Shorted	The Paper End indicator does not light when the 2nd paper tray is selected, even if there is no paper in the tray. The Paper Jam message will appear whenever a copy is made from the 2nd paper tray.
		Shorted	
By-pass Paper End	136-12 (BICU)	Open	The Paper End indicator lights when the bypass tray is selected, even if there is paper in the tray.
		Shorted	The Paper End indicator does not light when the bypass tray is selected, even if there is no paper in the tray. The Paper Jam message will appear whenever a copy is made from the bypass tray.
Exit	124-2 (BICU)	Open	The Paper Jam message will appear whenever a copy is made (paper has not reached the sensor).
		Shorted	The Paper Jam message appears even if there is no paper at the sensor.
Toner Density	125-3 (BICU)	Open	SC390 is displayed.
		Shorted	
Image Density	123-2 (BICU)	Open	The toner density control process is changed (see the note below the table).
		Shorted	
Scanner H.P. (D158/D159)	318-2 (SIO)	Open	SC120 shows.
		Shorted	

Component	CN	Condition	Symptom
Scanner H.P. (D160/D161/D170)	404-14	Open	SC120 shows.
		Shorted	
Platen Cover (D158/D159)	318-5 (SIO)	Open	APS and Auto Reduce/Enlarge do not function correctly.
		Shorted	If the Start button is pressed with the platen cover or ARDF closed, "Cannot detect original size" is displayed.
Platen Cover (D160/D161/D170)	402-2 (SIO)	Open	APS and Auto Reduce/Enlarge do not function correctly.
		Shorted	If the Start button is pressed with the platen cover or ARDF closed, "Cannot detect original size" is displayed.
APS 1 (D158/D159)	313-2 (SIO)	Open	The CPU cannot detect the original size properly. APS and Auto Reduce/Enlarge do not function correctly.
		Shorted	
APS 2 (D158/D159)	313-5 (SIO)	Open	The CPU cannot detect the original size properly. APS and Auto Reduce/Enlarge do not function correctly.
		Shorted	
APS (Width) (D160/D161/ D170)	404-11, 14 (BICU)	Open	The CPU cannot detect the original size properly. APS and Auto Reduce/Enlarge do not function correctly.
		Shorted	
APS (Length) (D160/D161/ D170)	404-5, 8 (BICU)	Open	The CPU cannot detect the original size properly. APS and Auto Reduce/Enlarge do not function correctly.
		Shorted	
Duplex Entrance	143-2 (BICU)	Open	The Paper Jam message will appear whenever a duplex copy is made (paper has not reached the sensor).
		Shorted	The Paper Jam message appears even if there is no paper at the sensor.

Component	CN	Condition	Symptom
Duplex Exit	143-5 (BICU)	Open	The Paper Jam message will appear whenever a duplex copy is made (paper has not reached the sensor).
		Shorted	The Paper Jam message appears even if there is no paper at the sensor.
Inverter (D158/D159/D160/ D161)	145-4 (BICU)	Open	The Paper Jam message will appear whenever a duplex copy is made (paper has not reached the sensor).
		Shorted	The Paper Jam message appears even if there is no paper at the sensor.

5

↓ Note

- SC392 is activated when the CPU detects an ID sensor error during developer initialization (SP2-801). However, SC392 is not displayed on the LCD but simply logged in the SC log (SMC printout), unless the technician exits SP Mode as soon as an error message is displayed.

Switches

Component	CN	Condition	Symptom
Upper Paper Size	115- 1,2,3,5 (BICU)	Open	The CPU cannot detect the proper paper size, and misfeeds may occur when a copy is made from the 1st paper tray.
		Shorted	
Vertical Transport Door	110-5 (BICU)	Open	The Cover Open indicator is lit even if the vertical transport door is closed.
		Shorted	The Cover Open indicator is not lit even if the vertical transport door is opened.
Lower Paper Size	113- 1,2,3,5 (BICU)	Open	The CPU cannot detect the proper paper size, and misfeeds may occur when a copy is made from the 2nd paper tray.
		Shorted	
By-pass Paper Size	136- 3,4,5,6,7 (BICU)	Open	The CPU misdetects or is not able to detect the size of the paper set in the bypass tray, causing possible misfeeds when feeding from this tray.

Component	CN	Condition	Symptom
Right Door	124-5 (BICU)	Open	The Cover Open indicator is lit even if the right door is closed.
		Shorted	The Cover Open indicator is not lit even if the right door is open.
Front/Right Cover	130-1 (BICU)	Open	The Cover Open indicator is lit even if doors are closed.
		Shorted	The Cover Open indicator is not lit even if doors are open.
Main	281-3,4 (PSU)	Open	The machine does not turn on.
		Shorted	The machine does not turn off.

Blown Fuse Conditions

All the fuses in the following table are on the power supply board.

The fuses below are not replaceable.

Fuse	Rating	
	NA/TWN	EU/AA/CHN
FU1	15A/250V	8A/250V
FU2	8A/250V	5A/250V
FU3	1A/250V	1A/250V
FU4	5A/250V	5A/250V
FU5	6.3A/250V	6.3A/250V
FU6	6.3A/250V	6.3A/250V

6. Service Tables

Service Program Mode

↓ Note

- Do not let the user access the SP mode. Only service representatives are allowed to access the SP mode. The machine quality or its operation is NOT guaranteed if persons other than service representatives accesses the SP mode.

SP Tables

See "Appendices" for the following information:

System/Copy SP Tables

Printer SP Tables

Scanner SP Tables

Firmware Update

Firmware Update Procedure (D158/D159)

Before You Begin

An SD card is a precision device. Always observe the following precautions when you handle SD cards:

- Always switch the machine off before you insert an SD card. Never insert the SD card into the slot with the power on.
- Do not remove the SD card from the service slot after the power has been switched on.
- Never switch the machine off while the firmware is downloading from the SD card.
- Keep SD cards in a safe location where they are not exposed to high temperature, high humidity, or exposure to direct sunlight.
- Always handle SD cards with care. Do not bend or scratch them. Do not let the SD card get exposed to shock or vibration.
- Make sure that the write protection of an SD card is unlocked when you download an application to it. If not, downloading fails and a download error (e.g. Error Code 44) occurs during a firmware upgrade.
- Keep the following points in mind when you use the firmware update software:
- "Upload" means to send data from the machine to the SD card. "Download" means to send data from the SD card to the machine.
- To select an item on the LCD, touch the appropriate button on the soft touch-screen of the LCD.
- Disconnect the Ethernet interface cable, Gigabit Ethernet cable, IEEE1284 interface cable and remove the Wireless LAN interface board before you start the firmware update procedure. Make sure that the machine is disconnected from the network to prevent a print job for arriving while the firmware update is in progress.

Preparation

- If the SD card is blank, copy the entire "romdata" folder onto the SD card.
- If the card already contains the "romdata" folder, copy the "D158" folder onto the card.

If the card already contains folders up to "D158", copy the necessary firmware files (e.g. D158xxxx.fwu) into this folder.

Note

- Do not put multiple machine firmware programs on the same SD card. Copy the only model firmware you want.

Updating Procedure

1. Turn the main power switch off.

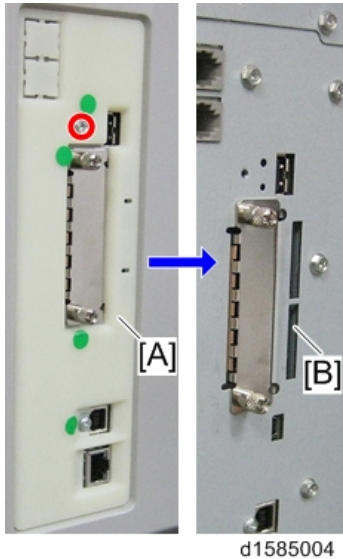

2. Remove the slot cover [A] (⚙ x 1).
3. Insert the SD card into SD Card Slot 2 [B]. Make sure the label on the SD card faces the front side of the machine.
4. Slowly push the SD card into the slot so it locks in place. You will hear it click. Make sure the SD card locks in place.

⚠ Note

- To remove the SD, push it in to unlock the spring lock. Then release it so it pops out of the slot.
5. Disconnect the network cable if the machine is connected to a network.
 6. Switch the main power switch on. After about 45 seconds, the initial version update screen appears on the LCD in English.
 7. On the screen, touch the button or press the corresponding number key on the operation panel to select the item in the menu that you want to update.

ROM/NEW	What it means
ROM:	Tells you the number of the module and name of the version currently installed. The first line is the module number, the second line the version name.
NEW:	Tells you the number of the module and name version on the SD card. The first line is the module number, the second line the version name.

Note

- Controller, engine and operation panel firmware cannot be updated at the same time. It is recommended to update firmware modules one by one.

8. Touch "UpDate (#)" to start the update.

Note

- The progress bar appears on the operation panel.
9. The "Update is Done" message appears on the operation panel after completing the updating. The message differs depending on the firmware that has been updated.
10. Switch the machine main power switch off when you see the "Update is Done" message or follow the procedure that is displayed on the operation panel.
11. Press in the SD card to release it. Then remove it from the slot.
12. Switch the machine on for normal operation.

Firmware Update Error

6

If firmware update fails, an error code appears.

The following example (E36) reports that the program which you wish to update is not in the machine or the data in the machine you wish to update does not correspond to the data in the card.

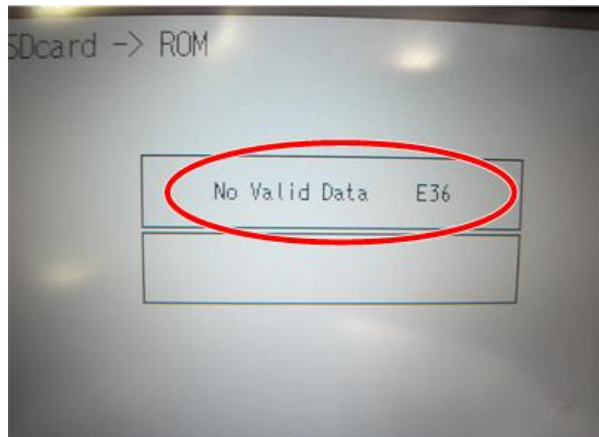

w_m1242089

Firmware Update Procedure (D160/D161/D170)

Engine (BICU)

An IC card and the bridge board [A] (with FFC [B]) are required for updating the engine firmware.

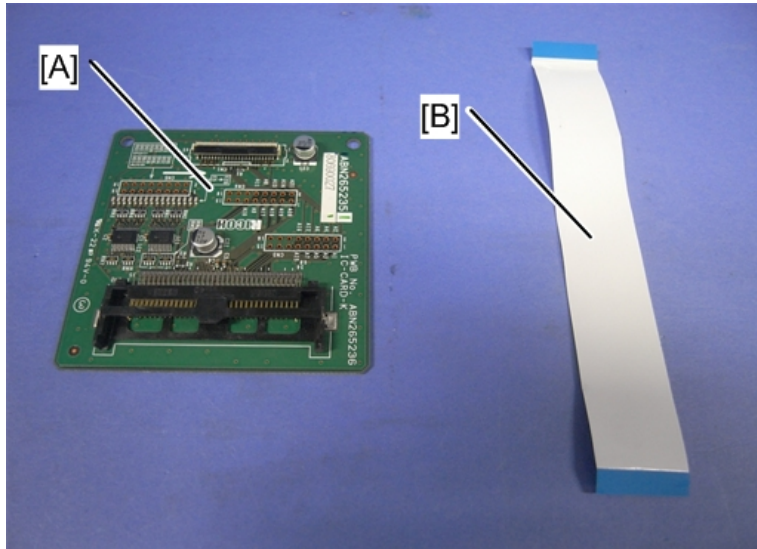

d1582156

1. Acquire the update data then install it on the IC card.
2. Insert the IC card [A] into the bridge board [B].
3. Connect the FFC to the board, and pull the hook [C] up to lock it. Be sure to attach the FFC on its correct side as shown below.

6

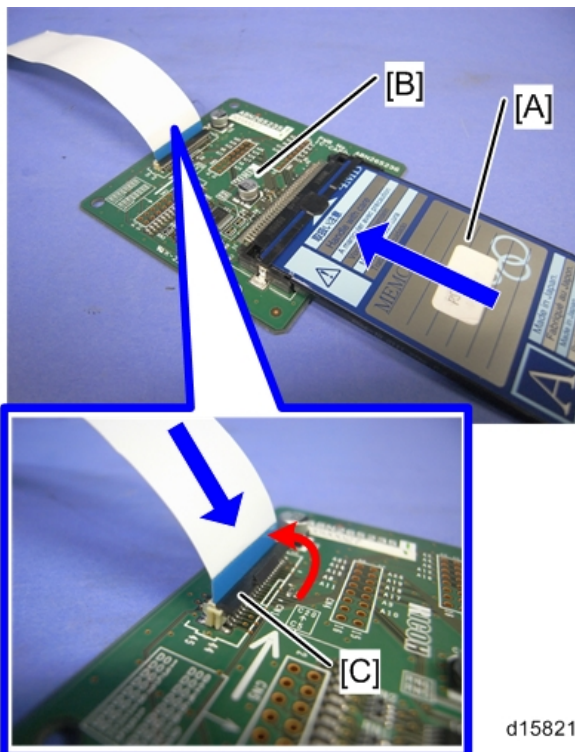

d1582157

4. Turn the main power switch off, and connect the bridge board and BICU board (CN190).

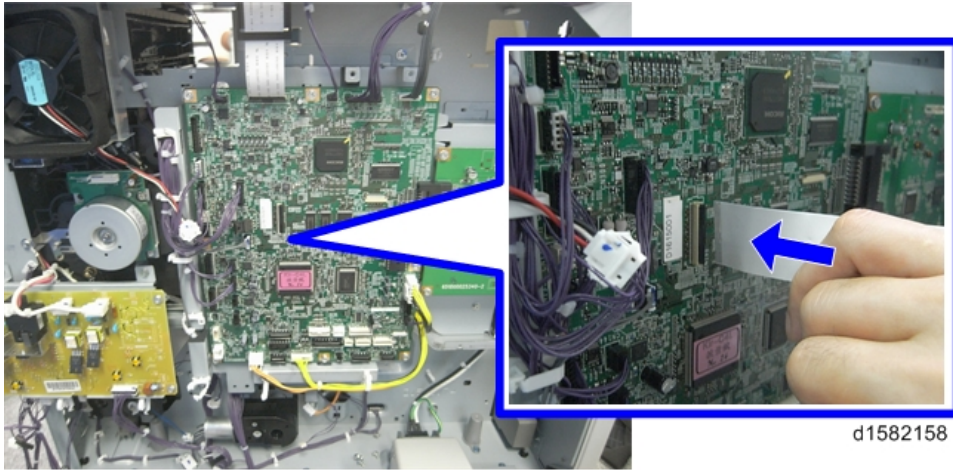

5. Turn the main switch on while holding down the operation switch [A] on the operation panel.



6. "BOOT (IC CARD)" appears, then switch to SP5-827-001 (Program Download) on the display.
7. Press "Execute". Update will start.
8. "End" appears, then confirm the version and the SUM value on the display.
9. Turn the main power OFF and detach the FFC from the BICU board.

GDI (Printer/Scanner)

An SD card is used to update the controller firmware.

1. Setup a folder on the SD card, "model name"(E.g., "D161").
2. Re-name the update file to "D161*****.brn", and save under the relevant folder on the SD Card.

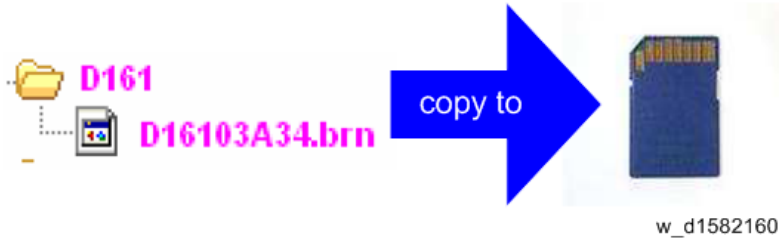
**Note**

- The name of the new firmware saved in the SD card should be made up of numbers '0' to '9' or characters "A" to "Z". E.g., "D16103A34.brn" is correct, "D161_03A4.brn" is incorrect.

3. Remove the slot cover [A] (ⓘ x 1).
4. Insert the SD card into SD Card Slot 2 [B]. Make sure the label on the SD card faces the front side of the machine.

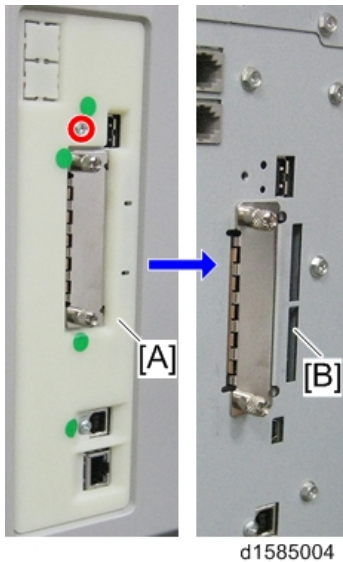

5. Turn the update switch (SW2) [A] on.

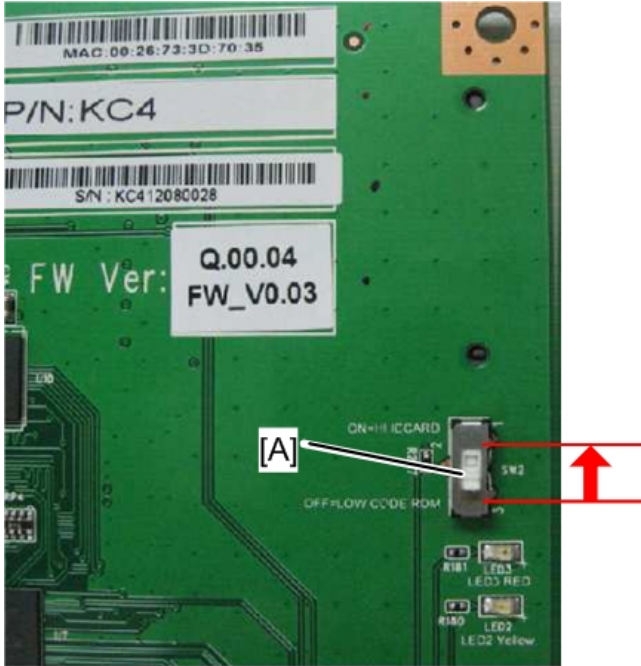

- 6. Turn the main power switch. "Please wait..." appears.
- 7. Press the "OK" key
- 8. Press "Execute". Update will start.

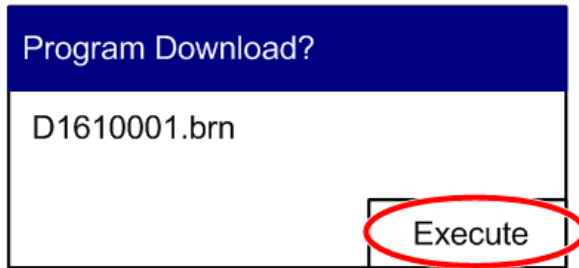
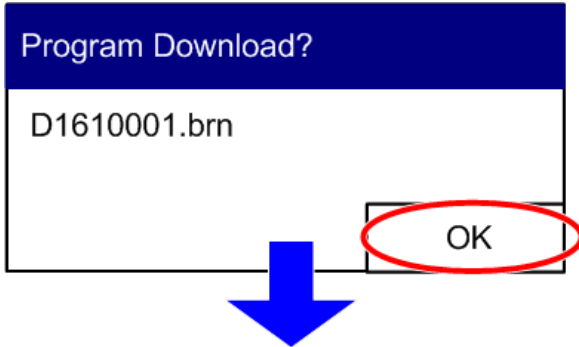

w_d1582162

9. After update is finished, turn off the main power, switch SW2 to OFF, and unplug the SD card.
10. Turn on the main power, then the new firmware will be working.

Note

- During firmware update, there is no LED indication (no lighting).
- When update is finished, A Yellow LED [A] flashes if the update was OK or a Red LED [B] if the update failed.



d1582163

NVRAM Data Upload/Download

Uploading Content of NVRAM to an SD card (D158/D159)

Do the following procedure to upload SP code settings from NVRAM to an SD card.

↓ Note

- This data should always be uploaded to an SD card before the NVRAM is replaced.
 - Make sure that the write protection of an SD card is unlocked
1. Do SP5-990-001 (SMC Print) before you switch the machine off. You will need a record of the NVRAM settings if the upload fails.
 2. Switch the machine main power switch off.

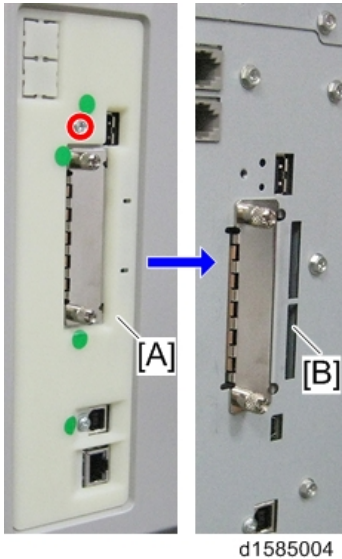

3. Remove the SD slot cover [A] (1 x 1).
4. Insert the SD card into SD card slot 2 [B]. Then switch the machine on.
5. Execute SP5-824-001 (NVRAM Data Upload) and then press the "Execute" key.
6. The following files are copied to an NVRAM folder on the SD card when the upload procedure is finished. The file is saved to the path and the following filename:

NVRAM\<<serial number>.NV

Here is an example with Serial Number "K5000017114":

NVRAM\K5000017114.NV

7. In order to prevent an error during the download, be sure to mark the SD card that holds the uploaded data with the number of the machine from which the data was uploaded.

Downloading an SD Card to NVRAM (D158/D159)

Do the following procedure to download SP data from an SD card to the NVRAM in the machine.

★ Important

- If copying of the data required for NV-RAM replacement fails, you need to specify the region and serial number when you replace the NV-RAM.
- Contact your supervisor for details on how to enter the serial number and destination code.
- SC995 or "Fusing Unit Setting Error" can be shown until the serial number and destination code are correctly programmed.

↓ Note

- The NVRAM data download may fail if the SD card with the NVRAM data is damaged, or if the connection between the controller and BCU is defective.
- Do the download procedure again if the download fails.
- Do the following procedure if the second attempt fails:
Enter the NVRAM data manually using the SMC print you created before uploading the NVRAM data.

1. Switch the machine main power switch off.

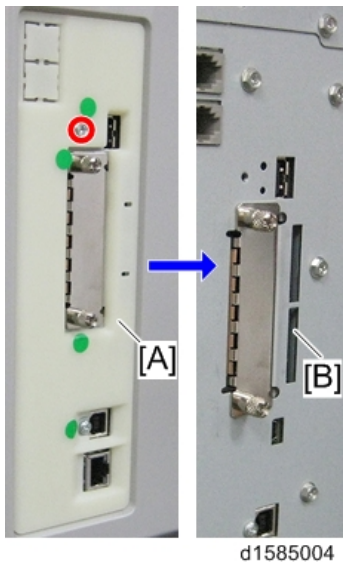

2. Remove the SD slot cover [A] (1 x 1).
3. Insert the SD card with the NVRAM data into SD Card Slot 2 [B].
4. Switch the machine main power switch on.
5. Do SP5-825-001 (NVRAM Data Download) and press the "Execute" key.

Note

- The serial number of the file on the SD card must match the serial number of the machine for the NVRAM data to download successfully. The download fails if the serial numbers do not match.

This procedure does not download the following data to the NVRAM:

- Total Count
- C/O, P/O Count

NVRAM Data Upload/Download (D160/D161/D170)

Engine

D160/D161/D170 models do not support "uploading/downloading" functions, that are usually used in order to save the data stored in the BICU NVRAM out to external media for back-up before memory clearing. So if you need to make a back-up of the data, do the following steps.

1. Print out all SMCs.
2. Prepare a new NV-RAM
3. Remove the original NV-RAM and install the new NV-RAM that you just prepared.
4. Turn on the machine. All engine SP data will be overwritten to the default values from the new NV-RAM (this does exactly the same as executing the engine memory clear in SP mode)
5. Refer the SMC list you printed in step 1 and input all data manually.
6. Now you have two NV-RAMs with the same settings. Keep one of these as a backup.

Before you change the NVRAM for uploading, do SP5-990-001 (SMC Print). You will need this engine data to restore the values after replacing the NV-RAM.

After replacing the NVRAM, specify the serial number and destination code of the machine.

Note

- Installing a new NV-RAM initializes the engine information in the NVRAM.

Controller

There is no removable NV-RAM on the CTL board. When the controller board is replaced, it is necessary to re-enter the information manually (see p.245 "When Replacing the New Controller Board (GDI)").

Using SP Modes

Adjusting Registration and Magnification

To adjust the registration and magnification, you need to use several service programs. The chart shows an example of the procedure to adjust the machine in the basic configuration.

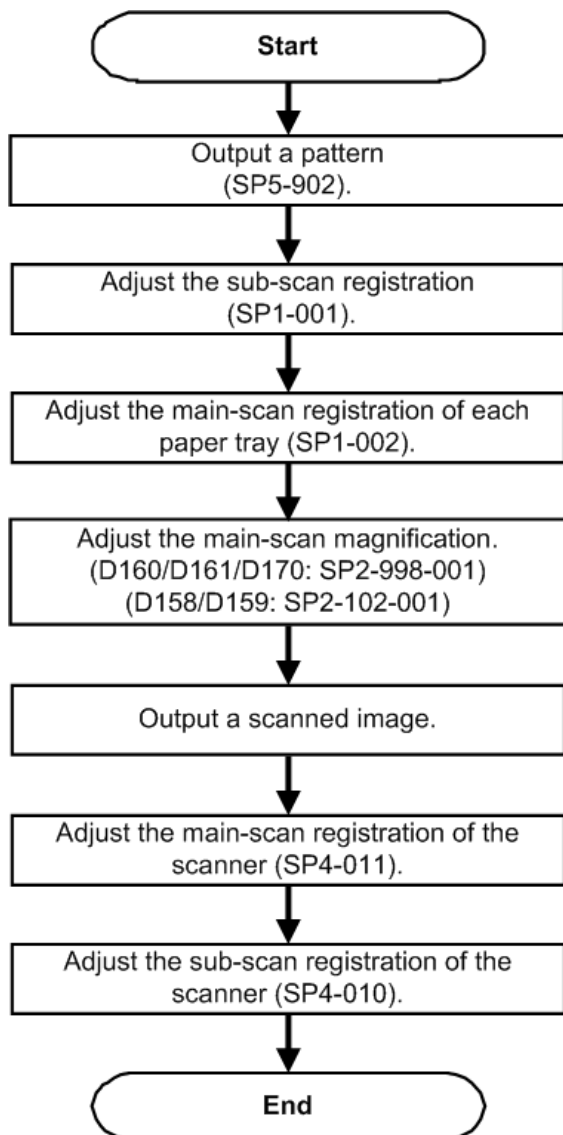

w_d1585050

Display APS Data (SP 4301 1)

D170/D160/D161 Models

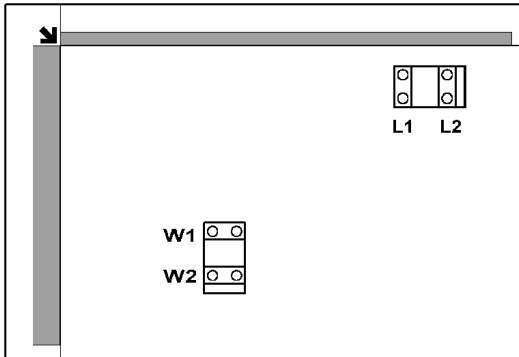

- Sensor Positions -

The APS (auto paper select) sensors are arranged as shown in the diagram.



6

- Reading the Data -

<p>Example 1</p> <p>Paper Size: 11000000 8¹/₂x13 </p> <p>DF Open: 1</p>	<p>Example 2</p> <p>Paper Size: 00110000 A4 </p> <p>DF Open: 0</p>
--	--

Example 1 indicates that the paper size and its orientation is "8¹/₂ x 13 SEF," and that the document feeder (or platen cover) is open. Example 2 indicates that the paper size and its orientation is "A4 LEF," and that the document feeder (or platen cover) is closed.

The "Paper Size" data starts with eight digits. The first digit indicates the output of L2; the second digit, L1; the third digit, W2; and the fourth digit, W1. The other four digits (from the fifth through the eighth) are always "0000." In Example 1, the APS sensors L2 and L1 detect paper (W2 and W1 do not).

In Example 2, APS sensors W2 and W1 detect paper (L2 and L1 do not). The paper size and its orientation is based on the outputs of these four APS sensors.

The "DF Open" data shows "1" or "0," indicating if the document feeder (or platen cover) is open or closed respectively. The data is based on the output of the platen cover sensor [A].

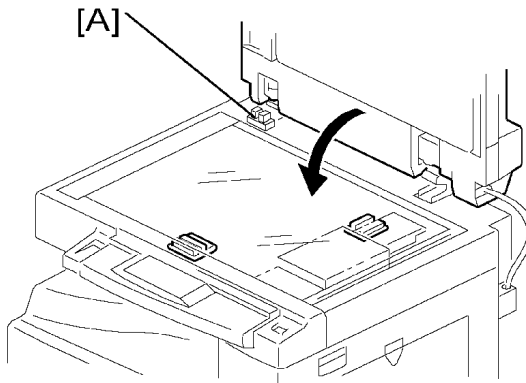

D158/D159 Models

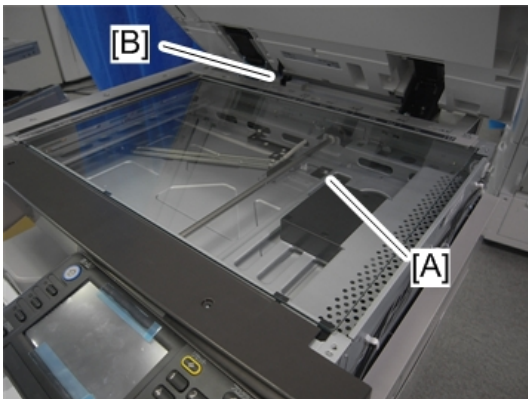

d1585020

- There is no APS sensor (width) in the scanner unit. However, the original width can be detected by CCD. The APS sensor (length) [A] detects the original length.
- The BICU board checks each sensor status when the platen cover sensor [B] is activated as it is closed. It detects the original size by the on/off signals it gets from each sensor.
- If the copy is made with the platen cover fully open, the CPU determines the original size from the sensor outputs after the Start key is pressed.

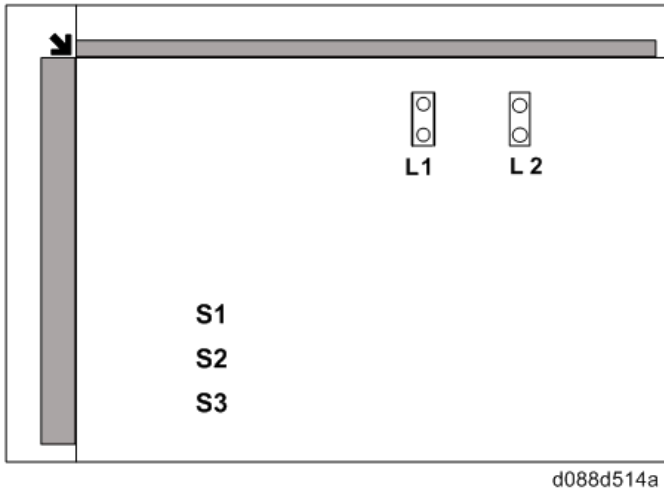

Memory Clear

6

The basic machine (D170: the machine without the optional controller) stores all the data in the NVRAM on the BICU. The data is cleared by SP5-801-002 (Memory Clear - Engine) (see exceptions).

The GDI or GW+ machines (the machines with the optional controller) store the engine data in the NVRAM on the BICU, and store the other data in the NVRAM on the optional controller. To distinguish between the engine data and the other data, see SP5-801-003 through -024. This service program (003-024) handles the controller data. Any data that is not handled by SP 5801 is the engine data. The data in the BICU NVRAM (engine data) is cleared by SP5-801-002.

Machine	Data	NVRAM	Cleared by	Remarks
Basic (D170)	All data	BICU	SP5-801-002	
GW+ (D158/ D159)	Engine data	BICU	SP5-801-002	Any data other than controller data
	Controller data	GW + Controller	SP5-801-001 -003 to -025	SCS, IMH, MCS, Copier application, Printer application, Scanner application, Web service/network application, NCS, R- Fax, DCS, UCS

Machine	Data	NVRAM	Cleared by	Remarks
GDI (D160/ D161)	Engine data	BICU	SP5-801-002	Any data other than controller data
	Controller data	GDI Controller	SP5-801-001 -003 to -025	Copier application, Printer application, Scanner application, Web service/network application

- Exceptions -

SP5-801-002 (Memory Clear - Engine) clears most of the settings and counters stored in the NVRAM on the BICU (the values return to their default values). However, the following settings are not cleared:

- SP5-807-001 (Area Selection)
- SP5-811-001 (Serial Num Input [Code Set])
- SP5-811-003 (Serial Num Input [ID2 Code Display])
- SP5-812-001 (Service TEL [Telephone])
- SP5-812-002 (Service TEL [Facsimile])
- SP5-907-001 (Plug & Play)
- SP 7 (Data Log)
- SP 8 (History)

SP5-801-002 (Memory Clear - Engine) after you have replaced the BICU NVRAM or when the BICU NVRAM data is corrupted. When the program ends normally, the message "Completed" shows. When you have replaced the controller NVRAM or when the controller NVRAM data is corrupted, use SP5-801-001 (Memory Clear / All Clear)

- With SD Card (D158/D159 models only)-

1. Upload the NVRAM data to the SD card (☛ p.308 "NVRAM Data Upload/Download").
2. Print out all SMC data lists (☛ p.333).

↓ Note

- Be sure to print out all the lists. You have to manually change the SP settings if the NVRAM data upload ends abnormally.
3. Select SP5-801-002.
 4. Press the OK key.
 5. Select "Execute." The messages "Execute?" followed by "Cancel" and "Execute" shows.
 6. Select "Execute."

7. When the program has ended normally, the message "Completed" shows. If the program has ended abnormally, an error message shows.
8. Press the cancel key.
9. Turn the main switch off and on.
10. Download the NVRAM data from the SD card.

- Without SD Card -

1. Print out all SMC data lists (● p.333).
2. Select SP5-801-002.
3. Press the OK key.
4. Select "Execute" The messages "Execute?" followed by "Cancel" and "Execute" show.
5. Select "Execute".
6. When the program has ended normally, the message "Completed" is displayed. If the program has ended abnormally, an error message shows.
7. Turn the main switch off and on.
8. Adjust the printer and scanner registration and magnification (● p.258 "Copy Adjustments Printing/Scanning").
9. Refer to the factory SMC lists, and enter any values that differ from the factory settings.
10. Initialize the TD sensor (SP2-801-001 (Developer Initialization))
11. Check the copy quality and the paper path.

Input Check

Input Check Table for Copier (D160/D161/D170)

- Conducting an Input Check -

1. Select SP5-803.
2. Select the number (see the table below) corresponding to the component.
3. Select "Execute." The copy mode is activated.
4. Either "01H" or "00H" appears (see the table below).

Num.	Sensor/Switch	00H	01H
001	Safety SW	OFF	ON
002	Safety SW-LD 5V	OFF	ON

Num.	Sensor/Switch	00H	01H
003	Right Cover SW	Closed	Open
004	Right Low Cover SW	Closed	Open
006	Upper Relay S	Not detected	Paper detected
007	Lower Relay S	Not detected	Paper detected
009	Registration Sensor	Not detected	Paper detected
010	Exit Sensor	Not detected	Paper detected
011	Duplex Inverter S	Not detected	Paper detected
012	Duplex Entrance S	Not detected	Paper detected
013	Duplex Exit S	Not detected	Paper detected
014	By-pass PE S	Not detected	Paper detected
015	By-pass P Size S	* 1	
016	Upper PE S	Not detected	Paper detected
017	Lower PE S	Not detected	Paper detected
018	Upper P Size SW	* 1	
019	Lower P Size SW	* 1	
032	Main M Lock	Not locked	Locked
033	Polygon M Lock	Not locked	Locked
035	Total CO Install	Not installed	Installed
036	Key CO Install	Not installed	Installed
037	L-Synchronization	Not detected	Detected
045	Platen Cover S	Closed	Open
050	Fan Motor Lock	Locked* 2	Not locked
051	2 Tray BK Install	Not installed	Installed
053	HP Sensor	Not detected	Detected
054	Duplex Fan M Lock	Locked* 2	Not locked

Num.	Sensor/Switch	00H	01H
055	Tray1: Tray Set	Not installed	Installed
056	Tray2: Tray Set	Not installed	Installed
057	Tray1: Paper Lift	Not at upper limit	At upper limit
058	Tray2: Paper Lift	Not at upper limit	At upper limit
059	Bypass: Length	Not detected	Paper detected
060	Bypass: HP	Not lifted	Lifted
061	Key Card Install	Not installed	Installed
071	Bank: CPU-Port2	*3	
072	Bank: CPU-Port3	*3	
073	Bank: CPU-PortA	*3	
074	Bank: CPU-PortB	*3	
080	ADF Lift Up	Closed	Open
081	ADF Feed Cover	Closed	Open
082	ADF Original Set	Not detected	Paper detected
083	ADF Registration	Not detected	Paper detected
084	ADF Exit Sensor	Not detected	Paper detected
085	ADF Rear Edge	Not detected	Paper detected
086	ADF Org Length1	*4	
087	ADF Org Length2	*4	
088	ADF Org Length3	*4	
089	ADF Org Width1	*4	
090	ADF Org Width2	*4	
091	ADF Org Width3	*4	
092	ADF Org Width4	*4	
093	ADF Skew Correct	Not detected	Paper detected

* 1: Paper size code

Copier	00	01	02	03	04	05	06	07
EU	LT SEF	B5 SEF	HLT LEF	A3 SEF	A4 SEF	B5 LEF	A4 LEF	B4 SEF
NA	LT SEF	B5 SEF	A5 LEF	DLT SEF	A4 SEF	Exe	LT LEF	LGT SEF

By-Pass Tray	00	01	02	03	04	05	06	07	08	09	0C	0C	10	11	18	19
EU	A5 SEF	A5 SEF	B5 SEF	B5 SEF	B5 LEF	B4 SEF	A5 LEF	A4 SEF	A5 SEF	A5 SEF	A4 SEF	A4 LEF	A5 SEF	A5 SEF	B6 SEF	B6 SEF
NA	HLT SEF	HLT SEF	LTS / LG	LTS / LG	LT LEF	DLT	LTS / LG	LTS / LG	HLT SEF	HLT SEF	LT LEF	LT LEF	HLT SEF	HLT SEF	HLT SEF	HLT SEF

*2: Fan motor lock – High speed rotation only.

*3: Bank: CPU-port information

*4: ADF: Combination of the APS sensor (length) and APS sensor (width)

Size (W x L) [mm]	APS sensor (Width)				APS sensor (Length)		
	1	2	3	4	B5	A4	LG
A3 SEF (297 x 420)	Y	Y	Y	Y	Y	Y	Y
B4 SEF (257 x 364)	Y	Y	-	-	Y	Y	Y
A4 SEF (210 x 297)	Y	-	-	-	Y	Y	-
A4 LEF (297 x 210)	Y	Y	Y	Y	-	-	-
B5 SEF (182 x 257)	-	-	-	-	Y	-	-
B5 LEF (257 x 182)	Y	Y	-	-	-	-	-
A5 SEF (148 x 210)	-	-	-	-	-	-	-

Size (W x L) [mm]	APS sensor (Width)				APS sensor (Length)		
	1	2	3	4	B5	A4	LG
A5 LEF (210 x 148)	Y	-	-	-	-	-	-
DLT SEF (11" x 17")	Y	Y	Y	-	Y	Y	Y
Folio SEF (11" x 15")	Y	Y	Y	-	Y	Y	Y
Folio SEF (10" x 14")	Y	Y	-	-	Y	Y	Y
LG SEF (8 ¹ / ₂ " x 14")	Y	-	-	-	Y	Y	Y
Foolscap SEF (8 ¹ / ₂ " x 13")	Y	-	-	-	Y	Y	Y
Folio SEF (8 ¹ / ₄ " x 13")	Y	-	-	-	Y	Y	Y
F SEF (8" x 13")	Y	-	-	-	Y	Y	Y
LT SEF (8 ¹ / ₂ " x 11")	Y	-	-	-	Y	-	-
LT LEF (11" x 8 ¹ / ₂ ")	Y	Y	Y	-	-	-	-
US EXE SEF (7 ¹ / ₄ " x 10 ¹ / ₂ ")	Y	-	-	-	Y	-	-
US EXE LEF (10 ¹ / ₂ " x 7 ¹ / ₄ ")	Y	Y	Y	-	-	-	-
Folio SEF (8" x 10")	Y	-	-	-	Y	-	-
HLT SEF (5 ¹ / ₂ " x 8 ¹ / ₂ ")	-	-	-	-	-	-	-
HLT LEF (8 ¹ / ₂ " x 5 ¹ / ₂ ")	Y	-	-	-	-	-	-
8K SEF (267 x 390)	Y	Y	Y	-	Y	Y	Y
16K SEF (195 x 267)	Y	-	-	-	Y	-	-
16K LEF (267 x 195)	Y	Y	Y	-	-	-	-

Remarks:

Y:	Detected
-:	Not supported

Input Check Table for Copier (D158/D159)

-Conducting an Input Check -

1. Select SP5-803.
2. Select the number (see the table below) corresponding to the component.
3. Select "Execute." The copy mode is activated.
4. Either "01H" or "00H" appears (see the table below).

Num.	Sensor/Switch	00H	01H
001	Tray 1: Paper Size Sensor	* 1: See "Table 1"	* 1: See "Table 1"
002	Tray 2: Paper Size Sensor	* 1: See "Table 1"	* 1: See "Table 1"
003	Tray 1: Tray Set Sensor	Installed	Not installed
004	Tray 2: Tray Set Sensor	Installed	Not installed
009	Tray 1: Paper End Sensor	Paper detected	Paper end
010	Tray 2: Paper End Sensor	Paper detected	Paper end
011	Tray 1: Paper Lift Sensor	Not at upper limit	At upper limit
012	Tray 2: Paper Lift Sensor	Not at upper limit	At upper limit
015	By-pass: Paper Size Sensor	* 1: See "Table 1"	* 1: See "Table 1"
016	By-pass: Paper End Sensor	Paper detected	Paper end
017	By-pass: Paper Length Sensor	Paper detected	Not detected
018	By-pass: Home Position Sensor	Lowered	Lifted
019	Paper Exit Sensor	Paper detected	Not detected
020	Paper Feed Sensor 1	Paper detected	Not detected
021	Paper Feed Sensor 2	Paper detected	Not detected
022	Registration Sensor	Paper detected	Not detected
023	Interchange Sensor	Paper detected	Not detected
024	Duplex: Exit Sensor	Paper detected	Not detected
025	Duplex: Entrance Sensor	Paper detected	Not detected
027	Front Safety Sw - 24V	Front door: Open	Front door: Closed
029	Right Cover Open	Right door: Closed	Right door: Open

Num.	Sensor/Switch	00H	01H
030	Duplex Fan Lock	Locked	Not locked
033	Fan Lock	Locked	Not locked
035	Main Motor Lock	Locked	Not locked
037	PCU Set	Not set	Set
039	Key Card Set	Set	Not set
040	Mechanical Counter Set	Not set	Set
041	Key Counter Set	*2: See "Table 2"	*2: See "Table 2"
042	BICU Version	*2: See "Table 2"	
043	VFEEDCOVER	Closed	Open
071	Bank: CPU-Port 2	*3: See "Table 3"	*3: See "Table 3"
072	Bank: CPU-Port 3	*3: See "Table 3"	*3: See "Table 3"
073	Bank: CPU-Port A	*3: See "Table 3"	*3: See "Table 3"
074	Bank: CPU-Port B	*3: See "Table 3"	*3: See "Table 3"
200	HP Sensor	Not home position	Home position
201	Platen Cover Sensor	Open	Closed

* 1: Table 1: Paper Size Switch

Paper Size		Bit 2	Bit 1	Bit 0
EU/ASIA	NA			
A3 SEF (DLT SEF)	DLT SEF(A3 SEF)	1	0	0
B4 SEF (LG SEF)	LG SEF (B4 SEF)	0	0	0
A4 SEF	A4 SEF	0	1	1
LT SEF	LT SEF	1	1	1
B5 SEF	B5 SEF	1	1	0
A4 LEF (LT LEF)	LT LEF (A4 LEF)	0	0	1

Paper Size		Bit 2	Bit 1	Bit 0
EU/ASIA	NA			
B5 LEF (Exe LEF)	Exe LEF (B5 LEF)	0	1	0
A5 LEF (HLT LEF)	HLT LEF (A5 LEF)	1	0	1

*2: Table 2: Indication

Status	Set detection 1 (Bit 1)	Set detection 2 (Bit 0)
Installed	0	1
Not installed	1	0

*3: Table 3: Bit meaning

CPU	Valid Bit number	Meaning
CPU-Port 2	Bit:0	Bank motor lock signal
CPU-Port 3	Bit:0	Paper pressure revision sensor 1
	Bit:2	Paper pressure revision sensor 2
CPU-Port A	Bit:0	Relay sensor
	Bit:1	Paper end detection 1
	Bit:2	Upper limit detection 1
	Bit:4	Upper limit detection 2
	Bit:6	Paper end detection 2
	Bit:7	Right door open detection

CPU	Valid Bit number	Meaning
CPU-Port B	Bit:0	Tray set detection 1
	Bit:1	Size detection 1-1
	Bit:2	Size detection 1-2
	Bit:3	Size detection 1-3
	Bit:4	Tray set detection 2
	Bit:5	Size detection 2-1
	Bit:6	Size detection 2-2
	Bit:7	Size detection 2-3

Output Check

6

- Conducting an Output Check -

Note

- To prevent mechanical or electrical damage, do not keep an electrical component on for a long time.
- 1. Select SP5-804.
- 2. Select the number (see the table below) corresponding to the component.
- 3. Select "ON."
- 4. To stop the operation, select "OFF."

- Output Check Table -

Number 005, 006, 040, and 041 may not respond when the fusing temperature is high.

Num.	Component (D160/D161/D170)
001	Main Motor Forward
002	Main Motor Reverse
003	Quenching Lamp
004	Toner Supply Motor Forward
005	Fan Motor High

Num.	Component (D160/D161/D170)
006	Fan Motor Low
007	Registration Clutch
008	By-pass Feed Clutch
009	Upper Feed Clutch
010	Lower Feed Clutch
011	BK-Low Lift Motor Up
012	BK-Low Lift Motor Down
013	Relay Clutch
014	BK-Relay Clutch
015	BK-Upper Feed Clutch
016	BK-Lower Feed Clutch
017	BK-Lift Motor
018	BK-Up Lift Motor Up
019	BK-Up Lift Motor Down
020	Duplex Inv Motor Reverse
021	Duplex Inv Motor Forward
022	Duplex Trans Motor
023	Duplex Gate Solenoid
024	Duplex Inv Motor Hold
025	Dup Trans Motor Hold
026	Polygon Motor
027	Polygon M/LD
038	Fusing Solenoid
040	Duplex Fan Motor High
041	Duplex Fan Motor Low

Num.	Component (D160/D161/D170)
042	1st Tray Up
043	1st Tray Down
044	2nd Tray Up
045	2nd Tray Down
046	Bypass Tray CL
071	Bank: Motor
072	Bank: Feed Clutch 1
073	Bank: Feed Clutch 2
074	Bank: Trans Clutch
080	ADF Feed Motor F
081	ADF Relay Motor F
082	ADF Feed Clutch
083	ADF Inverter Sol
084	ADF Feed Motor R
085	ADF Relay Motor R
086	ADF Feed Solenoid
087	ADF Stamp
202	Scanner Lamp
203	Scanner Light: BW

Num.	Component (D158/D159)
001	Main Motor: CW: High
002	Main Motor: CW: Low
003	Main Motor: CCW: High
004	Main Motor: CCW: Low

Num.	Component (D158/D159)
005	Duplex Motor: Hold
006	Duplex Motor: CCW: 582.4
007	Duplex Motor: CCW: 636.6
008	Duplex Motor: CCW: 708.5
009	Duplex Motor: CCW: 774.8
010	Interchange Motor: Hold
011	Interchange Motor: CW: 430.1
012	Interchange Motor: CW: 524.5
013	Interchange Motor: CCW: 430.1
014	Interchange Motor: CCW: 474.3
015	Interchange Motor: CCW: 524.5
016	Interchange Motor: CCW: 577.3
020	Toner Bottle Motor
021	1st Tray Up
022	1st Tray Down
023	2nd Tray Up
024	2nd Tray Down
025	Exhaust Fan Motor: High
026	Exhaust Fan Motor: Low
027	Duplex Fan
032	Registration CL
033	1st Paper Feed CL
034	2nd Paper Feed CL
035	Paper Transport CL 1
039	Interchange SOL

Num.	Component (D158/D159)
040	Fusing SOL
041	Dehumidification Heater
042	PP.: Image Transfer: -
043	PP.: Image Transfer: +
044	PP.: Separation Voltage
045	PP.: Development
046	PP.: Charge
047	P Sensor
048	Anti-static LED
049	Polygon Motor: High
050	Polygon Motor: Low
051	LD On
055	By-pass CL
056	By-pass Tray CL
071	Bank: Motor
072	Bank: Feed Clutch 1
073	Bank: Feed Clutch 2
074	Bank: Trans Clutch
202	Scanner Lamp

Serial Number Input (SP 5811) (D158/D159)

- Specifying Characters -

SP5-811-004 specifies the serial number.

A serial number consists of 11 characters. You can change each character by pressing one of the first 11 keys on the numeric keypad (1, 2, 3, ..., 9, 0, *).

For example, when you press the 1 key, the first character of the serial number changes as follows:

0 ⇒ 1 ⇒ 2 ⇒ ... ⇒ 8 ⇒ 9 ⇒ A ⇒ B ⇒ ... ⇒ X ⇒ Y ⇒ Z.

When you press the **2** key, the second character changes likewise.

You can specify a digit ("0" to "9") or a capital letter ("A" to "Z") for the first four characters of a serial number, and you can specify a digit in the other seven characters (not capital letters).

Test Pattern Print

D160/D161/D170 models

- Executing Test Pattern Printing -

1. Turn the main switch on.
2. Start the SP mode.
3. Select SP5-902-001 (Test Pattern).
4. Specify the pattern number and press the OK key.
5. Press the copy start key. The copy mode is activated
6. Specify copy settings and press the Start key.
7. To return to the SP mode, press the Stop key.

- Test Patterns -

Test Patterns Using VCU	
No.	Pattern
0	(No print)
1	Vertical Lines (Single Dot)
2	Horizontal Lines (Single Dot)
3	Vertical Lines (Double Dot)
4	Horizontal Lines (Double Dot)
5	Grid Pattern (Single Dot)
6	Grid Pattern (Double Dot)
7	Alternating Dot Pattern
8	Isolated one dot
9	Black Band (Horizontal)

Test Patterns Using VCU	
10	Trimming Area
11	Argyle Pattern (Single Dot)
12	Grayscales (Horizontal)
13	Grayscales (Vertical)
14	Grayscales (Vertical/Horizontal)
15	Grayscales (Vertical/Horizontal Overlay)
16	Grayscales With White Lines (Horizontal)
17	Grayscales with White Lines (Vertical)
18	Grayscales with White Lines (Vertical/Horizontal)

D158/D159 models

-Executing Test Pattern Printing-

1. Turn the main switch on.
2. Start the SP mode.
3. Select SP2-109-001 (Test Pattern Select).
4. Specify the pattern number and press the OK key.
5. Press the copy start key. The copy mode is activated
6. Specify copy settings and press the Start key.
7. To return to the SP mode, press the Stop key.

- Test Patterns -

Test Patterns	
No.	Pattern
0	None
1	Vertical Line (1 dot)
2	Vertical Line (2 dot)
3	Horizontal Line (1 dot)

Test Patterns	
4	Horizontal Line (2 dot)
5	Grid Vertical Line
6	Grid Horizontal Line
7	Grid Pattern Small
8	Grid Pattern Large
9	Argyle Pattern Small
10	Argyle Pattern Large
11	Independent Pattern (1 dot)
12	Independent Pattern (2 dot)
13	Independent Pattern (4 dot)
14	Trimming Area
15	Black Band (Horizontal)
16	Black Band (Vertical)
17	Checker Flag Pattern
18	Grayscale (Vertical)
19	Grayscale (Horizontal)
20	Full Dot Pattern
21	All White Pattern

Paper Jam Counters (SP 7504)

The table lists the menu numbers (the last three digits of SP7-504-XXX) and the paper jam timings and locations.

Code	Timing and Locations (D160/D161/D170)
001	At Power On
010	Off-Regist NoFeed

Code	Timing and Locations (D160/D161/D170)
011	Off-1 Vertical SN
012	On-1 Vertical SN
021	Off-2 Vertical SN
022	On-2 Vertical SN
031	Off-3 Vertical SN
032	On-3 Vertical SN
050	Off-Regist Bypass
060	Off-Regist Duplex
070	On-Regist SN
120	On-Exit SN
121	Off-Exit SN
122	On-Exit SN
123	Off-Dup Inverter
125	On-Dup Inverter
126	Off-Dup Entrance
127	On-Dup Entrance
128	Off-Duplex Exit
129	On-Duplex Exit
130	Off-1 Bin Exit
131	On-1 Bin Exit

Code	Timing and Locations (D158/D159)
001	Paper Jam Loc At Power On
003	Paper Jam Loc MainTray1:No Feed
004	Paper Jam Loc MainTray2:No Feed

Code	Timing and Locations (D158/D159)
005	Paper Jam Loc Bank 1: On
006	Paper Jam Loc Bank 2: On
008	Paper Jam Loc Bypass: On
009	Paper Jam Loc Duplex: On
011	Paper Jam Loc Vertical Transport 1: On
012	Paper Jam Loc Vertical Transport 2: On
017	Paper Jam Loc Registration: On
020	Paper Jam Loc Paper Exit: On
024	Paper Jam Loc Inverter SN: On
025	Paper Jam Loc Duplex Exit: On
027	Paper Jam Loc Duplex Entrance: On
051	Paper Jam Loc Vertical Transport 1: Off
052	Paper Jam Loc Vertical Transport 2: Off
053	Paper Jam Loc Bank: Transport: Off
057	Paper Jam Loc Registration Sensor: Off
060	Paper Jam Loc Paper Exit: Off
064	Paper Jam Loc Inverter SN: Off
065	Paper Jam Loc Duplex Exit: Off
067	Paper Jam Loc Duplex Entrance: Off

SMC Print (SP 5990)

SP 5990 outputs machine status lists.

1. Select SP5-990.
2. Select from the menu:

D160/D161/D170: 001 All, 002 SP, 003 User Program, 004 Logging Data, or 005 Big Font

D158/D159: 001 All (Data List), 002 SP (Mode Data List), 003 User Program, 004 Logging Data, 005 Diagnostic Report, 006 Non-Default, 007 NIB Summary, 008 Net File Log, 021 Copier User Program, 022 Scanner SP, 023 Scanner User Program, 024 SDK/J Summary, or 025 SDK/J Application information, 026 SP Print Mode Printer SP, 064 SP Print Mode Normal Count Print, 065 SP Print Mode User Code Counter, 066 SP Print Mode Key Operator Counter, 067 SP Print Mode Contact List Print, 069 SP Print Mode Heading1 print, 070 SP Print Mode Heading2 print, 071 SP Print Mode Heading3 print, 072 SP Print Mode Group List Print, 074 SP Print Mode Key Code Print, 080 SP Print Mode TCRU Print

Note

- The output given by the menu "Big Font" is suitable for faxing.

3. Press the "Execute" key.

D158/D159: The copy mode is activated

Specify copy settings and press the Start key. The machine status lists is output.

D160/D161/D170: The machine status list is output.

4. To return to the SP mode, press the Start key.

SMC Print to SD Card (SP 5992)

Overview

The SMC List Card Save (SP Text Mode) function is used to save the SMC list as CSV files to the SD card inserted into the operation panel SD-card slot or SD card slot 2 (lower). If both the slots are in use, the list is saved in the SD card in the operation panel preferentially.

Procedure

1. Turn the main power switch OFF.
2. Insert the SD card into the operation panel SD card slot. Then turn the power ON.
3. Enter SP mode.
4. Select "Copy SP".

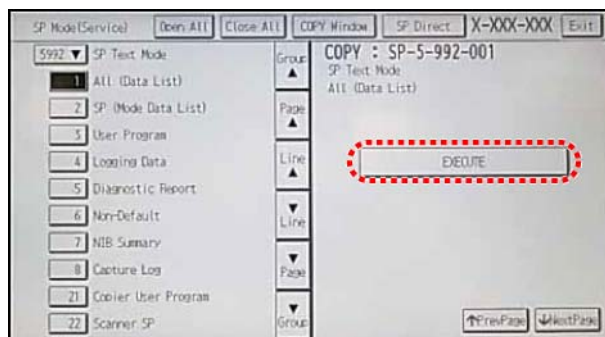

d1440127

5. Select SP-5992 "SP Text Mode".
6. Select a detail SP number shown below to save data on the SD card.
7. SP-5992-xxx (SP Text Mode)

Detail No.	SMC Categories to Save
001	All (Data List)
002	SP (Mode Data List)
003	User Program
004	Logging Data
005	Diagnostic Report
006	Non-Default
007	NIB Summary
008	Capture Log
021	Copier User Program
022	Scanner SP
023	Scanner User Program
024	SDK/J Summary
025	SDK/J Application Info
026	Printer SP

8. Press [EXECUTE].

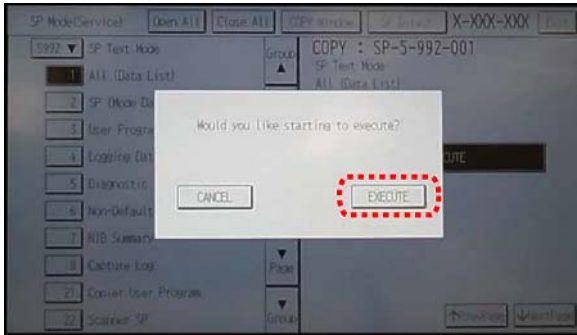

d1440128

9. Press [EXECUTE] again to start. Press [CANCEL] to cancel the saving.



d1440130

10. "It is executing it" is shown on the screen while executing.

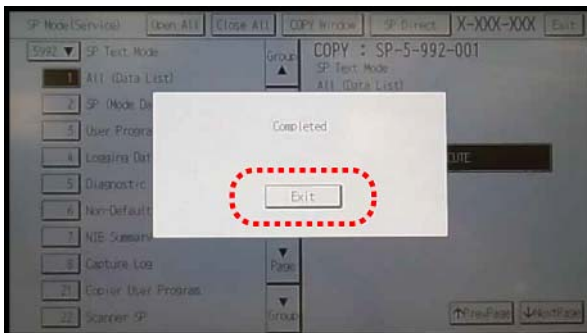

d1440129

11. Wait for 2 to 3 minutes until "Completed" is shown.

Note

- The SMC list saving may take from 2 to 3 minutes to complete.
- Press [CANCEL] to abort executing.

12. Press [Exit] to exit from SP mode.

File Names of the Saved SMC Lists

The SMC list data saved on the SD card will be named automatically. The file naming rules are as follows.

Example:

W490M000006_59921_20111011_53954.csv

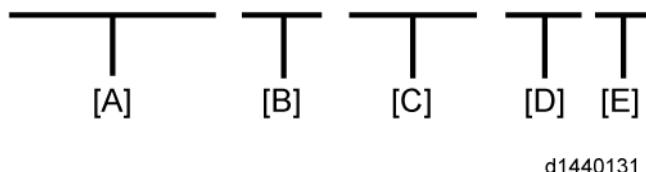

Note

- The information on jam history is saved in the NVRAM.
1. Select SP7-508.
 2. Select one of the menu items ("Latest 1" through Latest 10").
 3. Press the OK key. The summary of the jam history shows.
 4. To view more information, select "Detail."

Jam History Codes

Code	Meaning
001	Original Jam History Latest
002	Original Jam History Latest 1
003	Original Jam History Latest 2
004	Original Jam History Latest 3
005	Original Jam History Latest 4
006	Original Jam History Latest 5
007	Original Jam History Latest 6
008	Original Jam History Latest 7
009	Original Jam History Latest 8
010	Original Jam History Latest 9

SC History Display (SP 7403)**- Viewing the SC History -**

You can view the information on the most recent 10 events. The information on older events is deleted automatically.

Note

- The information on SC history is saved in the NVRAM.
1. Press the OK key.
 2. Select SP7-403.
 3. Select one of the menu items ("Latest 1" through Latest 10").

4. Press the OK key. The summary of the SC history appears.
5. To view more information, select "Detail."

SC History Codes

Code	Meaning
001	Latest
002	Latest 1
003	Latest 2
004	Latest 3
005	Latest 4
006	Latest 5
007	Latest 6
008	Latest 7
009	Latest 8
010	Latest 9

MEMO

Model K-C4/C4L
Machine Codes:
D158/D159D160/D161/D170

Appendices

18 Dec. 2012

TABLE OF CONTENTS

1. Appendix: General Specifications

- Specifications.....3
 - General Specifications.....3
- Supported Paper Sizes.....7
 - Original Size Detection.....7
 - Paper Feed.....10
 - Mainframe, Bank (Optional Paper Trays), Bypass Tray.....10
 - Paper Exit.....12
 - Main: Mainframe / 1-bin: 1-bin tray (D158/D159 only).....12
- Software Accessories.....15
 - Printer Drivers.....15
 - D158/D159.....15
 - D160/D160/D170.....15
 - Scanner and LAN Fax drivers.....16
 - D158/D159.....16
 - D160/D161/D170.....17
- Optional Equipment.....18
 - ARDF (D724).....18
 - ARDF (D684).....19
 - One-Tray Paper Tray Unit.....19
 - Two-Tray Paper Tray Unit.....20
 - One-Bin Tray.....21

2. Appendix: PM Tables

- Maintenance Tables.....23
 - Preventive Maintenance Items.....23
 - Mainframe (D158, D159).....23
 - Mainframe (D170, D160, D161).....26

3. Appendix: Service Program Mode Tables

- Main SP Tables-1.....31
 - SP1-XXX (Feed).....31
- Main SP Tables-2.....45
 - SP2-XXX (Drum).....45
- Main SP Tables-3.....62

SP3-XXX (Process).....	62
Main SP Tables-4.....	63
SP4-XXX (Scanner).....	63
Main SP Tables-5.....	97
SP5-XXX (Mode).....	97
Main SP Tables-6.....	200
SP6-XXX (Peripherals).....	200
Main SP Tables-7.....	208
SP7-XXX (Data Log).....	208
System SP Tables-8.....	224
SP8-xxx: Data Log 2.....	224
Input and Output Check.....	256
Input Chek.....	256
Output Check.....	265
Printer SP Tables.....	272
SP1-XXX (Service Mode).....	272
D158/D159.....	272
Scanner SP Tables.....	285
SP1-XXX (System and Others).....	285
D158/159.....	285
SP2-XXX (Scanning-image quality).....	286
D158/D159.....	286
Test Pattern Printing.....	288
D158/D159.....	288
D160/D161/D170.....	289

1. Appendix: General Specifications

Specifications

General Specifications

Configuration:	Desktop	
Photosensitivity type:	OPC drum	
Original scanning:	One-dimensional solid-state scanning system through CCD (D158/D159) or CIS (D170/D160/D161)	
Copy Process:	Laser beam scanning/marking & electro-photographic printing.	
Development:	Dry two-component magnetic brush development system	
Fusing:	Heating roller pressure system	
Resolution:	Scanning originals: 600 dpi Copying: 600 dpi	
Exposure glass:	Stationary original exposure type	
Original reference position:	Rear left corner	
Warm-up time:	Less than 20 seconds (23°C (73.4°F), rated voltage)	
Originals:	Sheet/Book/Object	
Maximum original size:	A3/11" x 17"	
Copy Paper Size:	Trays:	A3 LEF - A5 SEF, 11" x 17" LEF - 5 ¹ / ₂ " x 8 ¹ / ₂ " SEF
	Bypass:	A3 LEF - A6 LEF, 11" x 17" LEF - 5 ¹ / ₂ " x 8 ¹ / ₂ " LEF
	Bypass (Custom size):	Vertical: 90–297 mm, 3.55"–11.69" Horizontal: 148–600 mm, 5.83"–23.62"
Copy Paper Weight:	Paper Tray:	60–105 g/m ² , 16–28 lb.
	Bypass:	52–162 g/m ² , 14–43 lb.

Missing image area:	<p>Leading edge: 3 ± 2 mm (0.12" ± 0.08")</p> <p>Trailing edge: 3 ± 2 mm (0.12" ± 0.08") (4.2 ± 2 mm (0.17" ± 0.08") for even pages when using the duplex function.)</p> <p>Left edge: 2 ± 1.5 mm (0.08" ± 0.06")</p> <p>Right edge: 2 + 2.5/-1.5 mm (0.08" + 0.1"/-0.06")</p> <p>-Note-</p> <p>Missing image area of envelopes is 10 mm (0.40") and that of thick paper is 5 mm (0.20").</p>		
First copy time:	<p>D158/D159: Less than 5 seconds</p> <p>D170/D160/D161: Less than 6.5 seconds</p> <p>(A4 LEF, 8 1/2" × 11" LEF, 100 %, feeding from Tray 1)</p>		
Copying speed:	<p>D158/D160/D170: 20 copies/minute (A4 LEF, 8 1/2" × 11" LEF)</p> <p>D159/D161: 25 copies/minute (A4 LEF, 8 1/2" × 11" LEF)</p>		
Reproduction ratio:	3 enlargement and 4 reduction		
		A3/A4 Version	LT/DLT Version
	Enlargement	200 %	155 %
		141 %	129 %
		122 %	121 %
	Full Size	100 %	100 %
Reduction	93 %	93 %	
	82 %	78 %	
	71 %	65 %	
	50 %	50 %	
Zoom:	25 % to 200 %, in 1 % steps		
Continuous copying count:	1-99 copies		

Copy Paper Capacity:	Paper Tray:	250 sheets (D158/D160/D170) (80 g/m ² , 20 lb.) 250 sheets x 2 (D159/D161) (80 g/m ² , 20 lb.)
	Bypass Tray:	100 sheets
	Optional Paper Tray Unit:	500 x 2
Manual Image Density:		D160/D161/D170: 5 steps D158/D159: Less than 7 steps
Automatic Reset:		Default is 60 seconds. Can be set from 10 to 999 seconds with user tools.
Automatic Shut-off:		Default is 1 minute. Can be set from 1 to 240 minutes with user tools.
Toner Replenishment:		Cartridge replacement (260 g/cartridge)
Optional Equipment:		Platen cover Auto-reverse document feeder Paper tray unit (1 tray) Paper tray unit (2 trays) 1-bin tray (D158/D159 only)
Toner Yield:		NA, EU, Asia, Taiwan: 9k copies (A4 LEF, 6 % full black, 1 to 2 copying, normal text mode) China: 6.5k copies (A4 LEF, 6 % full black, 1 to 2 copying, normal text mode)
Memory:		D158/D159: 1024 MB D158/D159: 1536 MB (with expanded memory) D160/D161/D170: 128 MB
Power source:	Taiwan:	110V 60Hz 13A
	North and South America:	120 - 127V 60Hz 12A
	Europe, Asia, China:	220V - 240V 50/60Hz 8A

Power consumption:	Complete system:	Not more than 1.55 kW
	Sleep Mode:	D160/D161/D170: Not more than 2.5 W D158/D159: Not more than 1 W
	Off Mode:	D160/D161/D170: Not more than 1 W
Noise emission:	Complete system:	Stand-by: Not more than 40 dB(A) Copying: D159/D160/D170: Not more than 67 dB(A) D158/D161: Not more than 68.8 dB(A)
<p>-Note- The above measurements were made in accordance with ISO7779. Measurements were taken from the normal position of the operator.</p>		
Dimensions (W x D x H up to exposure glass):	D158	587 x 568 x 460 mm (23.1" x 22.4" x 18.1")
	D159	587 x 568 x 558 mm (23.1" x 22.4" x 22.0")
	D160/D170	587 x 568 x 431 mm (23.1" x 22.4" x 17.0")
	D161	587 x 568 x 529 mm (23.1" x 22.4" x 20.8")
Weight:	D158	Less than 45 kg (99.2 lb)
	D159/D161	Less than 47 kg (103.6 lb)
	D160	Less than 37 kg (81.6 lb)
	D170	Less than 35 kg (77.2 lb)
Duplex (D158/D159/D160/D161 only)		
Paper size:	A3 LEF, B4 JIS LEF, A4 SEF/LEF, B5 JIS SEF/LEF, A5 SEF/LEF, 11" x 17" LEF, 8" x 14" LEF, 8 1/2" x 13" LEF, 8 1/4" x 13" LEF, 8" x 13" LEF, 8 1/2" x 11" SEF/LEF, 7 1/4" x 10 1/2" SEF/LEF, 8K LEF, 16K SEF/LEF	

Supported Paper Sizes

Original Size Detection

D160/D161/D170 Models

Size (W x L) [mm]	NA		EU/Asia/Oceania		China	
	Platen	ARDF	Platen	ARDF	Platen	ARDF
A3 SEF (297 x 420)	-	Y	Y	Y	Y*1	
B4 SEF (257 x 364)	-	-	Y	Y	Y*1	
A4 SEF (210 x 297)	Y*1	Y	Y*1	Y	Y*1	
A4 LEF (297 x 210)	Y*1	Y	Y*1	Y	Y*1	
B5 SEF (182 x 257)	-	-	-	Y	Y*1	
B5 LEF (257 x 182)	-	-	Y	Y	Y*1	
A5 SEF (148 x 210)	-	-	Y*3	Y	Y*3	
A5 LEF (210 x 148)	-	-	Y*3	Y	Y*3	
B6 SEF (128 x 182)	-	-	-	-	-	-
B6 LEF (182 x 128)	-	-	-	-	-	-
DLT SEF (11" x 17")	Y	Y*2	-	Y*2	-	Y*2
LG SEF (8 ¹ / ₂ " x 14")	Y	Y*2	-	-	-	-
LT SEF (8 ¹ / ₂ " x 11")	Y*1	Y*2	Y*1	Y*2	-	Y*2
LT LEF (11" x 8 ¹ / ₂ ")	Y*1	Y*2	Y*1	Y*2	-	Y*2
HLT SEF (5 ¹ / ₂ " x 8 ¹ / ₂ ")	Y*3	Y	-	-	-	-
HLT LEF (8 ¹ / ₂ " x 5 ¹ / ₂ ")	Y*3	Y	-	-	-	-
F SEF (8" x 13")	-	-	Y*4	Y*4	-	Y*4

Foolscape SEF (8 ¹ / ₂ " x 13")	-	Y*2	Y*4	Y*4	-	Y*4
Folio SEF (8 ¹ / ₄ " x 13")	-	-	Y*4	Y*4	-	Y*4
Folio SEF (11" x 15")	-	Y*2	-	-	-	-
Folio SEF (10" x 14")	-	Y	-	-	-	-
Folio SEF (8" x 10")	-	Y*2	-	-	-	-
US EXE SEF (7 ¹ / ₄ " x 10 ¹ / ₂ ")	-	Y	-	-	-	-
US EXE LEF (10 ¹ / ₂ " x 7 ¹ / ₄ ")	-	Y*2	-	-	-	-
8K SEF (267 x 390)	-	-	-	Y*2	Y*1	Y*2
16K SEF (195 x 267)	-	-	-	Y*2	Y*1	Y*2
16K LEF (267 x 195)	-	-	-	Y*2	Y*1	Y*2

D158/D159 Models

Size (W x L) [mm]	NA		EU/Asia/Oceania/TW/China	
	Platen	ARDF	Platen	ARDF
A3 SEF (297 x 420)	-	Y	Y*1	Y
B4 SEF (257 x 364)	-	-	Y*1	Y
A4 SEF (210 x 297)	Y*1	Y	Y*1	Y
A4 LEF (297 x 210)	Y*1	Y	Y*1	Y
B5 SEF (182 x 257)	-	-	Y*1	Y
B5 LEF (257 x 182)	-	-	Y*1	Y
A5 SEF (148 x 210)	-	-	Y*3/Y*1	Y
A5 LEF (210 x 148)	-	-	Y*1	Y
B6 SEF (128 x 182)	-	Y*5	-	Y
B6 LEF (182 x 128)	-	Y*5	-	Y

DLT SEF (11" x 17")	Y	Y*2	-	Y*2
LG SEF (8 ¹ / ₂ " x 14")	Y	Y*2	-	-
LT SEF (8 ¹ / ₂ " x 11")	Y*1	Y*2	Y*1	Y*2
LT LEF (11" x 8 ¹ / ₂ ")	Y*1	Y*2	Y*1	Y*2
HLT SEF (5 ¹ / ₂ " x 8 ¹ / ₂ ")	Y*3	Y	-	-
HLT LEF (8 ¹ / ₂ " x 5 ¹ / ₂ ")	Y	Y	-	-
F SEF (8" x 13")	-	-	Y*4	Y*4
Foolscap SEF (8 ¹ / ₂ " x 13")	-	Y*2	Y*4	Y*4
Folio SEF (8 ¹ / ₄ " x 13")	-	-	Y*4	Y*4
Folio SEF (11" x 15")	-	Y*2	-	-
Folio SEF (10" x 14")	-	Y	-	-
Folio SEF (8" x 10")	-	Y*2	-	-
US EXE SEF (7 ¹ / ₄ " x 10 ¹ / ₂ ")	-	Y	-	-
US EXE LEF (10 ¹ / ₂ " x 7 ¹ / ₄ ")	-	Y*2	-	-
8K SEF (267 x 390)	-	-	Y*1	Y*2
16K SEF (195 x 267)	-	-	Y*1	Y*2
16K LEF (267 x 195)	-	-	Y*1	Y*2

* 1: The machine can detect the paper size depending on the setting of SP4-305-001 (D160/D161/D170), SP4-305-001 (D158/D159).

* 2: The machine can detect the paper size depending on the setting of SP6-016-001.

* 3: The machine can detect the paper size depending on the setting of SP4-303-001 (D160/D161/D170).

* 4: The machine can detect the paper size depending on the setting of SP5-126-001.

* 5: The machine can detect the paper size when the optional ARDF is installed.

Remarks:

Y	Supported
-	Not supported.

Paper Feed

Mainframe, Bank (Optional Paper Trays), Bypass Tray

Size (W x L) [mm]	Mainframe tray		Bank		Bypass-Tray	
	NA	EU/ Asia/ TW	NA	EU/ Asia/ TW	NA	EU/ Asia/ TW
A3 SEF (297 x 420)	S	A	S	A	M	M
A4 SEF (210 x 297)	A	A	A	A	M	M
A4 LEF (297 x 210)	S	A	S	A	M	M
A5 SEF (148 x 210)	-	-	M	B	M	M
A5 LEF (210 x 148)	S	A	A	A	M	M
A6 SEF (105 x 148)	-	-	-	-	M	M
B4 SEF (257 x 364)	S	A	S	A	M	M
B5 SEF (182 x 257)	A	A	A	A	M	M
B5 LEF (257 x 182)	S	A	S	A	M	M
B6 SEF (128 x 182)	-	-	M	M	M	M
DLT SEF (11" x 17")	A	S	A	S	M	M
Legal SEF (8 ¹ / ₂ " x 14")	A	S	A	S	S	M
Foolscap SEF (8 ¹ / ₂ " x 13")	M	M	M	M	M	M
LT SEF (8 ¹ / ₂ " x 11")	A	A	A	A	M	M

LT LEF (11" x 8 ¹ / ₂ ")	A	S	A	S	M	M
Gov. LG SEF (8 ¹ / ₄ " x 14")	M	M	M	M	M	M
Folio SEF (8 ¹ / ₄ " x 13")	M	M	M	M	M	M
F/GL SEF (8" x 13")	M	M	M	M	M	M
G LT SEF (8" x 10 ¹ / ₂ ")	M	M	M	M	M	M
G LT LEF (10 ¹ / ₂ " x 8")	M	M	M	M	M	M
Eng Quatro SEF (8" x 10")	M	M	M	M	M	M
Eng Quatro LEF (10" x 8")	M	M	M	M	M	M
Executive SEF (7 ¹ / ₄ " x 10 ¹ / ₂ ")	M	M	M	M	M	M
Executive LEF (10 ¹ / ₂ " x 7 ¹ / ₄ ")	A	S	A	S	M	M
HLT SEF (5 ¹ / ₂ " x 8 ¹ / ₂ ")	-	-	M	M	M	M
HLT LEF (8 ¹ / ₂ " x 5 ¹ / ₂ ")	A	S	-	-	M	M
Com10 SEF (4 ¹ / ₈ " x 9 ¹ / ₂ ")	-	-	-	-	M	M
Monarch SEF (3 ⁷ / ₈ " x 7 ¹ / ₂ ")	-	-	-	-	M	M
C5 SEF (162 x 229)	-	-	-	-	M	M
C5 LEF (229 x 162)	-	-	-	-	M	M
C6 Env SEF (114 x 162)	-	-	-	-	M	M
DL Env SEF (110 x 220)	-	-	-	-	M	M
8K SEF (267 x 390)	M	M	M	M	M	

16K SEF (195 x 267)	M	M	M	M	M	M
16K LEF (267 x 195)	M	M	M	M	M	M
12" x 18" SEF	-	-	-	-	M	M
Folio SEF (11" x 15")	M	M	M	M	M	M
Folio SEF (11" x 14")	M	M	M	M	M	M
Folio SEF (10" x 15")	M	M	M	M	M	M
Folio SEF (10" x 14")	M	M	M	M	M	M

Remarks:

A:	Supported: the sensor detects the paper size.
M:	Supported: the user specifies the paper size.
S:	Supported: depends on a technician adjustment
-:	Not supported

Paper Exit

Main: Mainframe / 1-bin: 1-bin tray (D158/D159 only)

Size (W x L) [mm]	Main	1-bin
A3 SEF (297 x 420)	A	A
A4 SEF (210 x 297)	A	A
A4 LEF (297 x 210)	A	A
A5 SEF (148 x 210)	A	A
A5 LEF (210 x 148)	A	A
A6 SEF (105 x 148)	A	A
B4 SEF (257 x 364)	A	A
B5 SEF (182 x 257)	A	A

Size (W x L) [mm]	Main	1-bin
B5 LEF (257 x 182)	A	A
B6 SEF (128 x 182)	A	A
Ledger (11" x 17")	A	A
Legal SEF (8.5" x 14")	A	A
Foolscap SEF (8.5" x 13")	A	A
Letter SEF (8.5" x 11")	A	A
Letter LEF (11" x 8.5")	A	A
Government LG SEF (8.25" x 14")	A	A
Folio SEF (8.25" x 13")	A	A
F/GL SEF (8" x 13")	A	A
G LT SEF (8" x 10.5")	A	A
G LT LEF (10.5" x 8")	A	A
Eng Quatro SEF (8" x 10")	A	A
Eng Quatro LEF (10" x 8")	A	A
Executive SEF (7.25" x 10.5")	A	A
Executive LEF (10.5" x 7.25")	A	A
Half Letter SEF (5.5" x 8.5")	A	A
Half Letter LEF (8.5" x 5.5")	A	A
Com10 SEF (4.125" x 9.5")	A	-
Monarch SEF (3.875" x 7.5")	A	-
C5 SEF (162 x 229)	A	-
C5 LEF (229 x 162)	A	-
C6 SEF (114 x 162)	A	-
DL SEF (110 x 220)	A	-
8K SEF (267 x 390)	A	A

Size (W x L) [mm]	Main	1-bin
16K SEF (195 x 267)	A	A
16K LEF (267 x 195)	A	A
12" x 18" SEF	A	A
11" x 15" SEF	A	A
11" x 14" SEF	A	A
10" x 15" SEF	A	A
10" x 14" SEF	A	A

Remarks:

A	Supported
-	Not supported

Software Accessories

The printer drivers and utility software are provided on one CD-ROM. An auto-run installer allows you to select which components to install.

Printer Drivers

D158/D159

Printer Language	Windows XP ^{*1*6}	Windows Vista ^{*2*6}	Windows 7 ^{*3*6}
PCL 5c/6	Yes	Yes	Yes
GDI	No	No	No
PS3	Yes	Yes	Yes

Printer Language	Windows Server 2003 ^{*4*6}	Windows Server 2008 or later ^{*5*6}	Macintosh ^{*7}
PCL 5c/6	Yes	Yes	No
GDI	No	No	No
PS3	Yes	Yes	Yes

D160/D160/D170

Printer Language	Windows XP ^{*1*6}	Windows Vista ^{*2*6}	Windows 7 ^{*3*6}
PCL 5c/6	No	No	No
GDI	Yes	Yes	Yes
PS3	No	No	No

Printer Language	Windows Server 2003 ^{*4*6}	Windows Server 2008 or later ^{*5*6}	Macintosh ^{*7}
PCL 5c/6	No	No	No

Printer Language	Windows Server 2003 ^{*4*6}	Windows Server 2008 or later ^{*5*6}	Macintosh ^{*7}
GDI	Yes	Yes	No
PS3	No	No	No

*1 Microsoft Windows XP Professional Edition / Home Edition

*2 Microsoft Windows Vista Ultimate / Enterprise / Business / Home Premium / Home Basic

*3 Microsoft Windows 7 Home Premium / Professional / Ultimate / Enterprise

*4 Microsoft Windows Server 2003 Standard Edition / Enterprise Edition / Microsoft Windows Server 2003 R2 Standard Edition / Enterprise Edition

*5 Microsoft Windows Server 2008 Standard / Enterprise / Microsoft Windows Server 2008 R2 Standard / Enterprise

*6 Supports both versions (32/64 bit)

*7 Mac OS X 10.5 or later (native mode).

↓ Note

- The PS3 drivers are all genuine AdobePS drivers, except for Windows 2000, which uses Microsoft PS.
- A PPD file for each operating system is provided with the driver.

Scanner and LAN Fax drivers

D158/D159

Driver	Windows XP ^{*1*6}	Windows Vista ^{*2*6}	Windows 7 ^{*3*6}
Network TWAIN	Yes	Yes	Yes
LAN-FAX	Yes	Yes	Yes

Driver	Windows Server 2003 ^{*4*6}	Windows Server 2008 or later ^{*5*6}	Macintosh
Network TWAIN	Yes	Yes	No
LAN-FAX	Yes	Yes	No

D160/D161/D170

Driver	Windows XP ^{*1*6}	Windows Vista ^{*2*6}	Windows 7 ^{*3*6}
Network TWAIN	Yes: D160, D161 No:D170	Yes: D160, D161 No:D170	Yes: D160, D161 No:D170
LAN-FAX	No	No	No

Driver	Windows Server 2003 ^{*4*6}	Windows Server 2008 or later ^{*5*6}	Macintosh
Network TWAIN	Yes: D160, D161 No:D170	Yes: D160, D161 No:D170	No
LAN-FAX	No	No	No

* 1 Microsoft Windows XP Professional Edition / Home Edition

* 2 Microsoft Windows Vista Ultimate / Enterprise / Business / Home Premium / Home Basic

* 3 Microsoft Windows 7 Home Premium / Professional / Ultimate / Enterprise

* 4 Microsoft Windows Server 2003 Standard Edition / Enterprise Edition / Microsoft Windows Server 2003 R2 Standard Edition / Enterprise Edition

* 5 Microsoft Windows Server 2008 Standard / Enterprise / Microsoft Windows Server 2008 R2 Standard / Enterprise

* 6 Supports both versions (32/64 bit)

 **Note**

- The LAN Fax driver lets you fax documents directly from your PC. Address Book Editor and Cover Sheet Editor must be installed as well.
- The Network TWAIN driver operates in 32-bit compatibility mode on 64-bit operating systems
- The Network TWAIN driver is provided on the scanner driver CD-ROM.

Optional Equipment

1

ARDF (D724)

Original Size:	<p>Standard sizes</p> <p>Single-sided mode: A3 to A5, 11" x 17" to 5¹/₂" x 8¹/₂"</p> <p>Double-sided mode: A3 to A5, 11" x 17" to 5¹/₂" x 8¹/₂"</p> <p>Non-standard sizes (Single-sided mode only)</p> <p>Max. width 297 mm</p> <p>Min. width 128 mm</p> <p>Max. length 1260 mm</p> <p>Min. length 128 mm</p>
Original Weight:	<p>Single-sided mode: 40 – 128 g/m², 10 – 34 lb</p> <p>Double-sided mode: 52 – 105 g/m², 14 – 28 lb</p>
Table Capacity:	50 sheets (81.4 g/m ² , 70 kg)
Original Standard Position:	Rear left corner
Separation:	FRR
Original Transport:	Roller transport
Original Feed Order:	From the top original
Reproduction Range:	33.3 to 200% (Sub scan direction only)
Power Source:	24 and 5 Vdc from the copier
Power Consumption:	33 W
Dimensions (W x D x H):	550 x 496 x 120 mm (21.6" x 19.6 x 4.7")
Weight:	Not more than 10 kg (22 lb)

ARDF (D684)

Original Size:	<p>Standard sizes (Single-sided mode only): A3 to B6, 11" x 17" to 5¹/₂" x 8¹/₂"</p> <p>Non-standard sizes (Single-sided mode only): Max. width 297 mm Min. width 128 mm Max. length 1,260 mm Min. length 128 mm</p>
Original Weight:	52 – 105 g/m ² (14 – 28 lb)
Table Capacity:	100 sheets (81.4 g/m ² , 22 lb)
Original Standard Position:	Rear left corner
Separation:	RF
Original Transport:	Roller transport
Original Feed Order:	From the top original
Reproduction Range:	50 – 200%
Power Source:	24 and 5 Vdc (from the mainframe)
Power Consumption:	42 W
Dimensions (W x D x H):	565 x 500 x 125 mm (22.4" x 19.6 x 4.9")
Weight:	Not more than 8.2 kg (18 lb)

One-Tray Paper Tray Unit

Paper Size:	A5 to A3, 5 ¹ / ₂ " x 8 ¹ / ₂ " SEF to 11" x 17"
Paper Weight:	60 – 105 g/m ² , 16 – 28 lb
Tray Capacity:	500 sheets (80 g/m ² , 20 lb) x 1 tray 570 sheets (67 g/m ² , 20 lb) x 1 tray
Paper Feed System:	Feed roller and friction pad

Paper Height Detection:	2 steps (100%, End)	
Power Source:	24 Vdc and 5Vdc (from the copier/printer): 120 Vac (120 V version) from the copier/printer when the optional tray heater is installed 220 – 240 Vac (230 V version) from the copier/printer when the optional tray heater is installed	
Power Consumption:	Max:	15 W (Copying/printing)
Weight:	12 kg (26.4 lb)	
Size (W x D x H):	553 x 548 x 137 mm (21.7" x 21.5 x 5.3")	

Two-Tray Paper Tray Unit

Paper Size:	A5 to A3, 5 ¹ / ₂ " x 8 ¹ / ₂ " SEF to 11" x 17"	
Paper Weight:	60 – 105 g/m ² , 16 – 28 lb	
Tray Capacity:	500 sheets (80 g/m ² , 20 lb) x 2 trays 570 sheets (67 g/m ² , 20 lb) x 2 trays	
Paper Feed System:	Feed roller and friction pad	
Paper Height Detection:	2 steps (100%, End)	
Power Source:	24 Vdc and 5Vdc (from the copier/printer): 120 Vac (120 V version) from the copier/printer when the optional tray heater is installed 220 – 240 Vac (230 V version) from the copier/printer when the optional tray heater is installed	
Power Consumption:	Max:	35 W (Copying/printing)
Weight:	25 kg (55 lb)	
Size (W x D x H):	553 x 548 x 271 mm (21.7" x 21.5 x 10.6")	

One-Bin Tray

Paper Size:	Width: 140 ~ 297 mm Length: 140 – 432 mm
Output Standard Position:	Center
Paper Weight:	60 – 105 g/m ² , 16 – 28 lb
Tray Capacity:	100 sheets (A4 LEF 80 g/m ² , 20 lb)
Power Source:	5 VDC, 24 VDC (from the copier)
Power Consumption:	Max. 9 W
Weight:	2 kg (4.4 lb)
Size (W x D x H):	193 x 388 x 63 mm (7.5" x 15.2 x 2.4") (when tray is not extended)

2. Appendix: PM Tables

Maintenance Tables

Preventive Maintenance Items

Chart: A4 (LT)/5%

Mode: 2 copies / original (prints/job)

Ratio 20%

Environment: Normal temperature and humidity

Yield may change depending on circumstances and print conditions.

Symbol keys: C: Clean, R: Replace, L: Lubricant, I: Inspect

Mainframe (D158, D159)

Item	60K	120K	180K	EM	Remarks
Scanner					
Reflector	C				Optics cloth
1st / 2nd / 3rd mirrors	C			C	Optics cloth
Scanner Guide Rails	C				Do not use alcohol.
Platen cover	C			I	Replace the platen sheet if necessary. Blower brush or alcohol
Exposure Glass	C			C	Blower brush or alcohol
Toner Shield Glass	C			C	Optics cloth
APS Sensor	C				Blower brush or dry cloth
PCU					
PCU	I				

Item	60K	120K	180K	EM	Remarks
OPC Drum	R				Replace parts every 60K
Charge Roller	R				
Charge Roller Cleaning Roller	R				
Drum Cleaning Blade	R				
Pick-off Pawls	R				
Transfer					
Transfer Rollers		R			
Static Charge Needle		R			
ID Sensor	C			C	Blower brush or dry cloth
Fusing					
Hot Roller		R/C			Lubricate the bearings, when replacing hot roller.
Pressure Roller		R			
Fusing Thermistors		R			
Hot roller stripper pawls	C	R			Washed with alcohol after cleaning with OA cleaner.
Fusing Entrance Guide Plates	C				Washed with alcohol after cleaning with OA cleaner.
Fusing Exit Guide Plates	C				Washed with alcohol after cleaning with OA cleaner.

Item	60K	120K	180K	EM	Remarks
Bearing		C			Lubricate if necessary.
Paper Path					
Registration Roller	C			C	Damp cloth
Registration Sensor				C	Blower brush or dry cloth
Registration Roller Dust Blade	C			C	Blower brush
Feed Rollers (Tray)		R		C	Damp cloth
Friction Pad (Tray)		R		C	Blower brush or dry cloth
Home position Sensor (Tray)				C	Blower brush or dry cloth
By-pass Feed Roller				C	Blower brush or dry cloth
By-pass Friction Pad				C	Blower brush or dry cloth
By-pass Home Position Sensor				C	Damp cloth
Paper Path (Optional Tray)					
Paper feed rollers				C	Damp cloth
Feed sensor				C	Blower brush or dry cloth
Feed Rollers				C	Blower brush or dry cloth
Separate roller				C	Blower brush or dry cloth
Paper Path (Duplex)					
Duplex Rollers				C	Damp cloth

Item	60K	120K	180K	EM	Remarks
Duplex Entrance Sensor				C	Blower brush or dry cloth
Duplex Exit Sensor				C	Blower brush or dry cloth
Output					
Exit Roller				C	Damp cloth
Reverse Roller				C	Damp cloth
Reverse Sensor				C	Blower brush or dry cloth

Mainframe (D170, D160, D161)

Item	60K	120K	180K	EM	Remarks
Scanner					
Platen cover	C			I	Replace the platen sheet if necessary. Blower brush or alcohol
Exposure Glass	C			C	Blower brush or alcohol
Toner Shield Glass	C			C	Optics cloth
PCU					
PCU	I				
OPC Drum	R				Replace parts every 60K
Charge Roller	R				
Charge Roller Cleaning Roller	R				
Drum Cleaning Blade	R				

Item	60K	120K	180K	EM	Remarks
Pick-off Pawls	R				
Transfer					
Transfer Rollers		R			
Static Charge Needle		R			
ID Sensor	C			C	Blower brush or dry cloth
Fusing					
Hot Roller		R/C			Lubricate the bearings, when replacing hot roller.
Pressure Roller		R			
Fusing Thermistors		R			
Hot roller stripper pawls	C	R			Washed with alcohol after cleaning with OA cleaner.
Cleaning Roller		C			Clean the bearing also. Washed with alcohol after cleaning with OA cleaner.
Fusing Entrance Guide Plates	C				Washed with alcohol after cleaning with OA cleaner.
Fusing Exit Guide Plates	C				Washed with alcohol after cleaning with OA cleaner.
Bearing		C			Lubricate if necessary.

Item	60K	120K	180K	EM	Remarks
Paper Path					
Registration Roller	C			C	Damp cloth
Registration Sensor				C	Blower brush or dry cloth
Registration Roller Dust Blade	C			C	Blower brush
Feed Rollers (Tray)		R		C	Damp cloth
Friction Pad (Tray)		R		C	Blower brush or dry cloth
Home position Sensor (Tray)				C	Blower brush or dry cloth
By-pass Feed Roller				C	Blower brush or dry cloth
By-pass Friction Pad				C	Blower brush or dry cloth
By-pass Home Position Sensor				C	Damp cloth
Paper Path (Optional Tray)					
Paper feed rollers				C	Damp cloth
Feed sensor				C	Blower brush or dry cloth
Feed Rollers				C	Blower brush or dry cloth
Separate roller				C	Blower brush or dry cloth
Paper Path (Duplex)					
Duplex Rollers				C	Damp cloth
Duplex Entrance Sensor				C	Blower brush or dry cloth

Item	60K	120K	180K	EM	Remarks
Duplex Exit Sensor				C	Blower brush or dry cloth
Output					
Exit Roller				C	Damp cloth
Reverse Roller				C	Damp cloth
Reverse Sensor				C	Blower brush or dry cloth

3. Appendix: Service Program Mode Tables

Main SP Tables-1

SP1-XXX (Feed)

1001	<p>[Leading Edge Registration] (D158/D159) [LE Regist] (D160/D161/D170) Leading Edge Registration Adjustment (Tray Location, Paper Type, Color Mode), Paper Type: Plain, Thick 1, Thick 2 or Thick3</p> <p>Adjusts the leading edge registration by changing the registration motor operation timing for each mode.</p> <p>Increasing a value: an image is moved to the trailing edge of paper. Decreasing a value: an image is moved to the leading edge of paper.</p>		
	002	Tray: Plain	*ENG [-9.0 to 9.0 / 0.0 / 0.1 mm / step]
003	Tray: Middle Thick	*ENG [-9.0 to 9.0 / 0.0 / 0.1 mm / step]	
004	Tray: Thick	*ENG [-9.0 to 9.0 / 0.0 / 0.1 mm / step]	
007	By-pass: Plain	*ENG [-9.0 to 9.0 / 0.0 / 0.1 mm / step]	
008	By-pass: Middle Thick	*ENG [-9.0 to 9.0 / 0.0 / 0.1 mm / step]	
009	By-pass: Thick	*ENG [-9.0 to 9.0 / 0.0 / 0.1 mm / step]	
013	Duplex: Plain:	*ENG [-9.0 to 9.0 / 0.0 / 0.1 mm / step]	
014	Duplex: Middle Thick	*ENG [-9.0 to 9.0 / 0.0 / 0.1 mm / step]	
015	Duplex: Thick	*ENG [-9.0 to 9.0 / 0.0 / 0.1 mm / step]	

1002	[Side-to-Side Registration] (D158/D159) [S-to-S Regist] (D160/D161/D170)		
	Adjusts the printing side-to-side registration from each paper feed station, using the Trimming Area Pattern (SP 5902, No.10). Adjustments are supported for all 4 possible feed trays (including optional trays). The SP 1002 1 setting is applied to all trays, not just the 1st tray. Settings for trays 2 to 4 are offsets relative to the SP 1002 1 setting. For duplex copies, the value for the front side is determined by SP 1002 1 to 4, and the value for the rear side is determined by SP 1002 6.		
001	By-pass	*ENG	[-4.0 to 4.0 / 0.0 / 0.1 mm / step]
002	Tray Main1	*ENG	[-4.0 to 4.0 / 0.0 / 0.1 mm / step]
003	Tray Main2	*ENG	[-4.0 to 4.0 / 0.0 / 0.1 mm / step]
004	Tray Bank1	*ENG	[-4.0 to 4.0 / 0.0 / 0.1 mm / step]
005	Tray Bank2	*ENG	[-4.0 to 4.0 / 0.0 / 0.1 mm / step]
006	Duplex	*ENG	[-4.0 to 4.0 / 0.0 / 0.1 mm / step]

1003	[Paper Buckle] Paper Buckle Adjustment (Tray Location, Paper Type)		
	Adjusts the amount of paper buckle on the registration roller.		
002	Tray1: Plain	*ENG	[-9 to 5 / 0 / 1 mm / step]
003	Tray1: Middle Thick	*ENG	[-9 to 5 / 0 / 1 mm / step]
004	Tray1: Thick	*ENG	[-9 to 5 / 0 / 1 mm / step]
007	Tray2/3/4: Plain	*ENG	[-9 to 5 / 0 / 1 mm / step]
008	Tray2/3/4: Plain: Middle Thick	*ENG	[-9 to 5 / 0 / 1 mm / step]
009	Tray2/3/4: Plain: Thick	*ENG	[-9 to 5 / 0 / 1 mm / step]
012	By-pass: Plain	*ENG	[-9 to 5 / 0 / 1 mm / step]
013	By-pass: Middle Thick	*ENG	[-9 to 5 / 0 / 1 mm / step]
014	By-pass: Thick	*ENG	[-9 to 5 / 0 / 1 mm / step]
018	Duplex: Plain	*ENG	[-9 to 5 / 0 / 1 mm / step]

019	Duplex: Middle Thick	*ENG	[-9 to 5 / 0 / 1 mm / step]
020	Duplex: Thick	*ENG	[-9 to 5 / 0 / 1 mm / step]

1007	[By-pass Size Adjust]		
	0: LT SEF 1: LG		
002	Bypass: 1 (Bypass Size Adj)	*ENG	[0 or 1 / 0 / 1/step]

1101	[Flicker Control] (D158/D159)		
	[Inrush Control] (D160/D161/D170)		
Enables or disables the Flicker Control.			
001	Flicker Control (Inrush Control)	*ENG	[0 or 1 / 0 / 1 / step] 0: Disable 1: Enable

1103	[Reload Permit Setting] (D158/D159)		
	[Reload Setting] (D160/D161/D170)		
Specifies the settings of the reload permit for cold temperature in color mode.			
001	0:OFF 1:ON 2:OFF+Temp (Set1)	*ENG	[0 to 2 / 0 / 1 / step] 0:OFF 1:ON 2:OFF+Temp
002	Reload: Temp: Center (Temp:Cen)	*ENG	[100 to 150 / 125 / 1 deg / step]
003	Reload Temp: Ends (Temp:Ends)	*ENG	[100 to 150 / 125 / 1 deg / step]
004	Temp: Cold: Center (Temp: Cold: Cen)	*ENG	[100 to 150 / 125 / 1 deg / step]

005	Temp: Cold: End (Temp:Cold:Ends)	*ENG	[100 to 150 / 125 / 1 deg / step]
-----	-------------------------------------	------	--

1105	[Fusing Temperature Adjustment] (D158/D159)		
	[Fusing Temp Adj] (D160/D161/D170)		
Adjusts the target fusing temperature. "Center" indicates the center of the roller; "End" indicates the front and rear ends.			

001	Roller Center: Plain1 (D158/ D159)	*ENG	[100 to 200 / 145 / 1 deg / step]
002	Roller Ends: Plain1 (D158/ D159)	*ENG	[100 to 200 / 145 / 1 deg / step]
003	Roller Center: Plain2 (Roller Cen:Pl2)	*ENG	[100 to 200 / 155 / 1 deg / step]
004	Roller Ends: Plain2 (Roller Ends:Pl2)	*ENG	[100 to 200 / 155 / 1 deg / step]
005	Roller Center: M-Thick (D158/ D159)	*ENG	[100 to 200 / 160 / 1 deg / step]
006	Roller Ends: M-Thick (D158/ D159)	*ENG	[100 to 200 / 160 / 1 deg / step]
007	Roller Center: Thick Paper (Roller Cen:Thick)	*ENG	[100 to 200 / 175 / 1 deg / step]
008	Roller Ends: Thick Paper (Roller Ends:Thick)	*ENG	[100 to 200 / 175 / 1 deg / step]
009	Roller Center: Thin (D158/ D159)	*ENG	[100 to 200 / 135 / 1 deg / step]
010	Roller Ends: Thin (D158/D159)	*ENG	[100 to 200 / 135 / 1 deg / step]
011	Energy Saver	*ENG	[100 to 200 / 135 / 1 deg / step]
012	Wait Temp: Center (Wait Temp:Cen)	*ENG	[100 to 200 / 145 / 1 deg / step]
013	Wait Temp: Ends	*ENG	[100 to 200 / 150 / 1 deg / step]

014	Thresh: S1	*ENG	[0 to 50 / 16 / 1 deg / step]
015	Thresh: delta t	*ENG	[0 to 50 / 0 / 1 deg / step]
016	Low: Plain1 (D158/D159)	*ENG	[0 to 30 / 5 / 1 deg / step]
017	Low: Plain2	*ENG	[0 to 30 / 5 / 1 deg / step]
018	Low: M-Thick (D158/D159)	*ENG	[0 to 30 / 5 / 1 deg / step]
019	Low: Thick	*ENG	[0 to 30 / 10 / 1 deg / step]
020	Registration Waiting: Plain 1 (D158/D159)	*ENG	[0 or 1 / 1 / 1 / step]
021	Registration Waiting: Plain2 (Waiting:Pl2)	*ENG	[0 or 1 / 1 / 1 / step]
022	Registration Waiting: M-Thick (D158/D159)	*ENG	[0 or 1 / 1 / 1 / step]
023	Registration Waiting:Thick (Waiting:Thick)	*ENG	[0 or 1 / 1 / 1 / step]
024	Waiting: Center Lower:Plain 1: Center (D158/D159)	*ENG	[0 to 60 / 60 / 1 deg / step]
025	Waiting: Center Lower:Plain 1: Ends (D158/D159)	*ENG	[0 to 60 / 60 / 1 deg / step]
026	Waiting: Center Lower:Plain2: Center (Lower:Pl2:cen)	*ENG	[0 to 60 / 60 / 1 deg / step]
027	Waiting: Center Lower:Plain2: Ends (Lower:Pl:ends)	*ENG	[0 to 60 / 60 / 1 deg / step]
028	Waiting: Center Lower:M-Thick: Center	*ENG	[0 to 60 / 5 / 1 deg / step]
029	Waiting: Center Lower:M-Thick: Ends	*ENG	[0 to 60 / 5 / 1 deg / step]

030	Waiting: Center Lower: Thick: Center (Lower Thick:cen)	*ENG	[0 to 60 / 0 / 1 deg / step]
031	Waiting: Center Lower: Thick: Ends (Lower Thick:ends)	*ENG	[0 to 60 / 0 / 1 deg / step]
032	Waiting: Center Upper: Plain1: Center (D158/D159)	*ENG	[0 to 60 / 40 / 1 deg / step]
033	Waiting: Center Upper: Plain1: Ends (D158/D159)	*ENG	[0 to 60 / 40 / 1 deg / step]
034	Waiting: Center Upper: Plain2: Center (Upper:Pl2:cen)	*ENG	[0 to 60 / 40 / 1 deg / step]
035	Waiting: Center Upper: Plain2: Ends (Upper:Pl2:ends)	*ENG	[0 to 60 / 40 / 1 deg / step]
036	Waiting: Center Upper: M- Thick: Center (D158/D159)	*ENG	[0 to 60 / 40 / 1 deg / step]
037	Waiting: Center Upper: M- Thick: Ends (D158/D159)	*ENG	[0 to 60 / 40 / 1 deg / step]
038	Waiting: Center Upper: Thick: Center (Upper:Thick:cen)	*ENG	[0 to 60 / 40 / 1 deg / step]
039	Waiting: Center Upper: Thick: Ends (Upper:Thick:ends)	*ENG	[0 to 60 / 40 / 1 deg / step]
040	Low: Thin (D158/D159)	*ENG	[0 to 30 / 5 / 1 deg / step]
041	Waiting: Thin (D158/D159)	*ENG	[0 or 1 / 1 / 1 deg / step]
042	Waiting: Center Lower: Thin:Center (D158/D159)	*ENG	[0 to 60 / 60 / 1 deg / step]
043	Waiting: Center Lower: Thin:Ends (D158/D159)	*ENG	[0 to 60 / 60 / 1 deg / step]

044	Waiting: Center Upper: Thin:Center (D158/D159)	*ENG	[0 to 60 / 40 / 1 deg / step]
045	Waiting: Center Upper: Thin:Ends (D158/D159)	*ENG	[0 to 60 / 40 / 1 deg / step]
046	Pint Ready: Center (Print Ready:cen)	*ENG	[120 to 180 / 150 / 1 deg / step]
047	Pint Ready: Ends (Print Ready:ends)	*ENG	[120 to 180 / 155 / 1 deg / step]

1106	[Fusing Temperature Display] Fusing Temperature Display (Heating or Pressure)		
	Displays the current temperature of the heating and pressure rollers.		
001	Roller Center	ENG	[-20 to 250 / 0 / 1 deg / step]
002	Roller Ends	ENG	[-20 to 250 / 0 / 1 deg / step]
	The heating roller has two lamps. One heats the center of the heating roller and the other heats both ends of the heating roller.		
003	In The Machine at Power On (Mac at Power On)	ENG	[-20 to 250 / 0 / 1 deg / step]
	The pressure roller has two lamps. One heats the center of the heating roller and the other heats both ends of the heating roller.		

1107	[Fusing Soft Start] (D160/D161/D170)		
	-		
003	Softstop 100V	*ENG	[0 to 1 / 0 / 1 / step]
004	Softstop 200V	*ENG	[0 to 1 / 0 / 1 / step]

1108	[Fusing Soft Start Setting] (D158/D159)		
	[Fusing Soft St Set] (D160/D161/D170)		
Sets the target temperature for immediately after reload temperature has been achieved or paper has been fed.			
001	Warming-Up	*ENG	[100 to 2000 / 1000 / 100 msec / step]

002	Print	*ENG	[100 to 2000 / 1000 / 100 msec / step]
003	Wait	*ENG	[100 to 2000 / 1000 / 100 msec / step]
004	Print Start	*ENG	[100 to 2000 / 1000 / 100 msec / step]
005	Print Start Time	*ENG	[0 to 999 / 5 / 1 sec / step]

1110	[Fan Control Timer] (D160/D161/D170)		
	Specifies the fan control time. The fan motor keeps its operating speed for the specified time before changing the speed or stopping. The fan control timer prevents the exhaust fan from suddenly stopping. This function protects the copier from overheating.		
001	Fan Control Timer	*ENG	[30 to 60 / 30 / 100 msec / step]

1112	[Image Process Temp.]		
	These SPs are used for the fusing temperature control for variable job images. This control saves the power consumption when the machine copies or prints a job text image in black and white mode.		
001	Correction Temp. : Normal: Level1	*ENG	[-25 to 10 / 0 / 1 deg / step]
002	Correction Temp. : Normal: Level2	*ENG	[-25 to 10 / -5 / 1 deg / step]

1124	[CPM Down Setting] (D160/D161/D170)		
	Sets the temperature differential used to calculate CPM down for low and high temperatures. Also, sets the interval for temperature checks for CPM down.		
001	Low:Down Temp. (Low:Down Tp)	*ENG	[-50 to 0 / -25 / 1 deg / step]
002	Low:Up Temp. (Low:Up Tp)	*ENG	[-50 to 0 / -5 / 1 deg / step]
003	Low :1st CPM	*ENG	[10 to 100 / 75 / 5 % / step]
004	Low :2nd CPM	*ENG	[10 to 100 / 65 / 5 % / step]
005	Low :3rd CPM	*ENG	[10 to 100 / 40 / 5 % / step]

006	High:1st CPM :Plain 1 (High:1st CPM:20)	*ENG	[10 to 100 / D158/D160/D161/ D170:60, D159:50 / 5%/step]
007	High:2nd CPM :Plain 1 (High:2nd CPM:20)	*ENG	[10 to 100 / D158/D160/D161/ D170:60, D159:50 / 1%/step]
008	High:3rd CPM (High:3rd CPM:20)	*ENG	[10 to 100 / D158/D160/D161/ D170:60, D159:50 / 5%/step]
009	High:1st CPM Down Temp.:A3 (High:1st Down:A3)	*ENG	[100 to 250 / 215 / 1deg/step]
010	High:2nd CPM Down Temp.:A3 (High:2nd Down:A3)	*ENG	[100 to 250 / 220 / 1deg/step]
011	High:3rd CPM Down Temp.:A3 (High:3rd Down:A3)	*ENG	[100 to 250 / 225 / 1 deg / step]
012	High:1st CPM Down Temp.:A4 (High:1st Down:A4)	*ENG	[100 to 250 / 215 / 1 deg / step]
013	High:2nd CPM Down Temp.:A4 (High:2nd Down:A4)	*ENG	[100 to 250 / 220 / 1 deg / step]
014	High:3rd CPM Down Temp.:A4 (High:3rd Down:A4)	*ENG	[100 to 250 / 225 / 1 deg / step]
015	High:1st CPM Down Temp.:B5 (High:1st Down:B5)	*ENG	[100 to 250 / 205 / 1 deg / step]
016	High:2nd CPM Down Temp.:B5 (High:2nd Down:B5)	*ENG	[100 to 250 / 205 / 1 deg / step]
017	High:3rd CPM Down Temp.: B5 (High:3rd Down:B5)	*ENG	[100 to 250 / 205 / 1 deg / step]
018	High:1st CPM Down Temp.:A5 (High:1st Down:A5)	*ENG	[100 to 250 / 205 / 1 deg / step]
019	High:2nd CPM Down Temp.:A5 (High:2nd Down:A5)	*ENG	[100 to 250 / 205 / 1 deg / step]

020	High:3rd CPM Down Temp.:A5 (High:3rd Down:A5)	*ENG	[100 to 250 / 205 / 1 deg / step]
021	High:1st CPM Down Temp.:A6 (High:1st Down:A6)	*ENG	[100 to 250 / 205 / 1 deg / step]
022	High:2nd CPM Down Temp.:A6 (High:2nd Down:A6)	*ENG	[100 to 250 / 205 / 1 deg / step]
023	High:3rd CPM Down Temp.:A6 (High:3rd Down:A6)	*ENG	[100 to 250 / 205 / 1 deg / step]
024	Judging Interval	*ENG	[1 to 250 / 10 / 1sec / step]
025	Setting Start Timing (Start Timing)	*ENG	[1 to 999 / 10 / 1 sec / step]
026	High:1st CPM:25 (D160/D161/ D170)	*ENG	[10 to 100 / 50 / 1 % / step]
027	High:2nd CPM:25 (D160/ D161/D170)	*ENG	[10 to 100 / 50 / 1 % / step]
028	High:3rd CPM:25 (D160/ D161/D170)	*ENG	[10 to 100 / 50 / 1 % / step]

1152	[Fusing Nip Band Check]		
	Checks and adjusts the nip of the hot roller and pressure roller.		
001	0:OFF, 1:ON	ENG	[0 or 1 / 1 / 1 / step]
002	Pre-idling Time	*ENG	[0 to 999 / 300 / 1 sec / step]
003	Stop Time	*ENG	[0 to 100 / 20 / 1 sec / step]

1159	[Fusing Jam Detection] (D158/D159) [Fusing Jam SC] (D160/D161/D170)		
	This SP mode detects SC559. Set this SP mode to 'Yes' if the machine experiences paper jam problems on a continual basis.		
001	SC Display (Fusing Jam SC)	*ENG	[0 to 1 / 0 / 1 / step]

1801	[MotorSpeedAdjust]		
	Adjusts the speeds of each motor.		
001	MainMonitor: 122	*ENG	[-4.00 to 4.00 / 0.00 / 0.01 % / step]
	Adjusts the speed of main motor.		
002	MainMonitor: 100 (D158/D159)	*ENG	[-4.00 to 4.00 / 0.00 / 0.01 % / step]
	Adjusts the speeds of main motor.		
010	Duplex:Low (D158/D159)	*ENG	[-4.0 to 4.0 / 0.0 / 0.1 % / step]
	Directly reflects the adjusted value.		
011	Duplex:High (D158/D159)	*ENG	[-4.0 to 4.0 / 0.0 / 0.1 % / step]
	Directly reflects the adjusted value		
024	Reverse:Low (D158/D159)	*ENG	[-4.0 to 4.0 / 0.0 / 0.1 % / step]
	Directly reflects the adjusted value		
029	Reverse:High (D158/D159)	*ENG	[-4.0 to 4.0 / 0.0 / 0.1 % / step]
	Directly reflects the adjusted value		

1902	[Zero Cross] (D160/D161/D170)		
	It reflects the number of zero-cross interrupted times that has been measured when frequency is determined.		
	More than 11 times: 60Hz		
	Less than 10 times: 50Hz		
001	Count Value	ENG	[0 to 255 / 0 / 1 / step]
	Less than 3 times: SC547		

1903	[Feed CI Re-energize]		
	Directly reflects the adjusted value.		
	<ul style="list-style-type: none"> • A "+" setting increases the amount of driving. • A "-" setting decreases the amount of driving. 		
001	By-pass Feed	*ENG	[-10 to 10 / 0 / 1 mm / step]

002	Tray1 Feed	*ENG	[-10 to 10 / 0 / 1 mm / step]
003	Tray2/3/4 (Other Teays)	*ENG	[-10 to 10 / 0 / 1 mm / step]

1907	[Paper Feed Timing Adj.]		
	Adjusts the timing of paper feed. (A "+" setting broadens paper feed interval, a "-" setting narrows paper feed interval.)		
005	Inverter Stop Position (Inverter Stop Pos)	*ENG	[-10 to 10 / 0 / 1 mm / step]
006	Inverter Wait	*ENG	[0 or 1 / 0 / 1 / step]
010	Main1 Plate Pressure (Main1 Plate Press)	*ENG	[-1000 to 1000 / 0 / 20 msec / step]
011	Main1 Plate Base Up (Main1 Plate Up)	*ENG	[-1000 to 1000 / 0 / 20 msec / step]
012	Main1 Plate Base Down (Main1 Plate Down)	*ENG	[-1000 to 1000 / 0 / 20 msec / step]
013	Main1 Plate Paper End (Main1 Plate End)	*ENG	[-500 to 500 / 0 / 20 msec / step]
015	Re-Feed Stop Position (Re-Feed Stop Pos)	*ENG	[-10 to 10 / 0 / 1 mm / step]
020	Main2 Plate Pressure (Main2 Plate Press)	*ENG	[-1000 to 1000 / 0 / 20 msec / step]
021	Main2 Plate Base Up (Main2 Plate Up)	*ENG	[-1000 to 1000 / 0 / 20 msec / step]
022	Main2 Plate Base Down (Main2 Plate Down)	*ENG	[-1000 to 1000 / 0 / 20 msec / step]
023	Main2 Plate Paper End (Main2 Plate End)	*ENG	[-500 to 500 / 0 / 20 msec / step]

032	BANK1 FEED TIMING ADJ C4b (TypeB Bank1)	*ENG	[-20 to 0 / 0 / 1 mm / step]
033	BANK2 FEED TIMING ADJ C4b (TypeB Bank2)	*ENG	[-20 to 0 / 0 / 1 mm / step]
034	BANK1 FEED TIMING ADJ C4c (TypeC Bank1)	*ENG	[-20 to 0 / 0 / 1 mm / step]
035	BANK2 FEED TIMING1 ADJ C4c (TypeC Bank2: <206)	*ENG	[-20 to 0 / 0 / 1 mm / step]
036	BANK2 FEED TIMING2 ADJ C4c (TypeC Bank2: >206)	*ENG	[-20 to 0 / 0 / 1 mm / step]

1908	[Paper Feed Timing Adj.] (D158/D159) [Option Tray Adj.] (D160/D161/D170)		
	Adjusts the timing of paper feed. (A "+" setting broadens paper feed interval, a "-" setting narrows paper feed interval.)		
001	1st Optional (D160/D161/ D170)	*ENG	[-2 to 2 / 0 / 1 / step]
	Adjusts the paper feeding pressure for 1st optional tray. -2 ----- 0 ----- +2 ←Low Pressure High Pressure→ (uses when double feed) (uses when non-paper feed) Controls 100ms by 1 step.		
002	2nd Optional (D160/D161/ D170)	*ENG	[-2 to 2 / 0 / 1 / step]
	Adjusts the paper feeding pressure for 2nd optional tray. -2 ----- 0 ----- +2 ←Low Pressure High Pressure→ (uses when double feed) (uses when non-paper feed) Controls 100ms by 1 step.		
015	Junction Gate SOL1:ON	*ENG	[-10 to 10 / 0 / 1 mm / step]

017	Junction Gate SOL1:OFF	*ENG	[-10 to 10 / 0 / 1 mm / step]
-----	------------------------	------	-------------------------------

1911	[By-pass Envelope]		
	0 = Disabled / 1 = Enabled The program dedicated to envelope printing runs when you enable this program (SP 1911 1) and you select "Thick Paper" as the paper type of the by-pass tray (System Settings > Tray Paper Settings > Paper Type: Bypass Tray).		

001	By-Pass Envelope	*ENG	[0 or 1 / 0 / 1 / step]
-----	------------------	------	-------------------------

1950	[Fan Cooling Time Set] (D158/D159)		
	Adjust the rotation time for each fan motor after a job end.		

001	Fan	*ENG	[0 to 600 / 0 / 1 sec / step]
-----	-----	------	-------------------------------

1991	[Max Fusing Lamp Duty] (D158/D159)		
	[Max Fusing Lp Duty] (D160/D161/D170)		
-			

001	Roller Center	*ENG	[40 to 100 / 100 / 10 % / step]
-----	---------------	------	---------------------------------

002	Roller Ends	*ENG	[40 to 100 / 100 / 10 % / step]
-----	-------------	------	---------------------------------

003	After Warming-up- Center (After Warmup Cen)	*ENG	[40 to 100 / 100 / 10 % / step]
-----	--	------	---------------------------------

004	After Warming-up- Ends (After Warnup Ends)	*ENG	[40 to 100 / 100 / 10 % / step]
-----	---	------	---------------------------------

1996	[Heater Forced Off]		
	-		

005	After Printing	*ENG	[0 to 120 / 7 / 10 sec / step]
-----	----------------	------	--------------------------------

006	Temp (After Printing Tp)	*ENG	[100 to 200 / 135 / 1 deg / step]
-----	-----------------------------	------	-----------------------------------

Main SP Tables-2

SP2-XXX (Drum)

2001	[Charge Roller Bias Adjust] (D158/D159)		
	[CR Bias Adj] (D160/D161/D170)		
	-		
001	Setting (Copying) (Printing)	*ENG	[-2100 to -1500 / -1600 / 10 vol / step]
	Adjusts the voltage applied to the charge roller when printing. The actually applied voltage changes automatically as charge roller voltage correction is carried out. The value you set here becomes the base value on which this correction is carried out.		
002	ID Sensor Pattern	*ENG	[0 to 400 / 200 / 10 vol / step]
	Adjusts the voltage applied to the charge roller when generating the Vsdp ID sensor pattern (as part of charge roller voltage correction). The actual chargeroller voltage is obtained by adding this value to the value of SP 2001 1.		
003	Temporally Input (D158/D159)	*ENG	[-2500 to 0 / 0 / 10 vol / step]
	Enter the voltage values directly. Background dirt occurs when the value is too low, and easy to adhere the toner careers when it is too high. Between 1600V to -1800V recommended.		

2005	[Charge Bias Correction] (D158/D159)		
	[CR Bias Vsdp] (D160/D161/D170)		
001	Vsdp Min (Min)	*ENG	[0 to 100 / 90 / 1 % / step]
	Sets the minimum value of Vsdp.		
002	Vsdp Max (Max)	*ENG	[0 to 100 / 95 / 1 % / step]
	Sets the maximum value of Vsdp.		

003	Revision Step (Step)	*ENG	[0 to 200 / 50 / 10 vol / step]
-----	-------------------------	------	--

2101	[Erase Margin Adj] (D160/D161D170)		
	Adjusts the width of the erased area of the each edges.		
001	Leading Edge	*ENG	[0.0 to 90.0 / 20.0 / 0.1 mm / step]
002	Trailing Edge	*ENG	[0.0 to 90.0 / 30.0 / 0.1 mm / step]
003	Left Side	*ENG	[0.0 to 90.0 / 20.0 / 0.1 mm / step]
004	Right Side	*ENG	[0.0 to 90.0 / 20.0 / 0.1 mm / step]

2102	[Main Scan Mag. Adjustment] (D158/D159)		
	Adjust the image scale for main scan magnification. <ul style="list-style-type: none"> • A "+" setting stretches the image. • A "-" setting compresses the image. 		
001	-	*ENG	[-0.5 to 0.5 / 0.0 / 0.1 % / step]

2103	[Erase Margin Adjustment] (Area, Paper Size) (D158/D159)		
	Adjusts the erase margin by deleting image data at the margins.		
001	Lead Edge	*ENG	[0.0 to 9.0 / 3.0 / 0.1 mm / step]
	Directly reflects the adjusted value		
002	Trailing Edge	*ENG	[0.0 to 9.0 / 3.0 / 0.1 mm / step]
	Directly reflects the adjusted value		
003	Left	*ENG	[0.0 to 9.9 / 2.0 / 0.1 mm / step]
004	Right	*ENG	
005	Duplex Trail.: L Size: Plain	ENG	[0.0 to 4.0 / 1.2 / 0.1 mm / step]
006	Duplex Trail.: M Size: Plain	ENG	[0.0 to 4.0 / 0.8 / 0.1 mm / step]
007	Duplex Trail.: S Size: Plain	ENG	[0.0 to 4.0 / 0.6 / 0.1 mm / step]
008	Duplex Left: Plain	ENG	[0.0 to 1.5 / 0.3 / 0.1 mm / step]

009	Duplex Right: Plain	ENG	[0.0 to 1.5 / 0.3 / 0.1 mm / step]
010	Duplex Trail.: L Size: Thick	ENG	[0.0 to 4.0 / 1.0 / 0.1 mm / step]
011	Duplex Trail.: M Size: Thick	ENG	[0.0 to 4.0 / 0.6 / 0.1 mm / step]
012	Duplex Trail.: S Size: Thick	ENG	[0.0 to 4.0 / 0.4 / 0.1 mm / step]
013	Duplex: Left: Thick	ENG	[0.0 to 1.5 / 0.1 / 0.1 mm / step]
014	Duplex: Right: Thick	ENG	[0.0 to 1.5 / 0.1 / 0.1 mm / step]

2109	[Test Pattern] (D158/D159)		
	Generates the test pattern using "COPY Window" tab in the LCD.		
001	Pattern Selection	ENG	[0 to 21 / 0 / 1 / step]
	0: None 1: Vertical Line (1 dot) 2: Vertical Line (2 dot) 3: Horizontal (1 dot) 4: Horizontal (2 dot) 5: Grid Vertical Line 6: Grid Horizontal Line 7: Grid pattern Small 8: Grid pattern Large 9: Argyle Pattern Small 10: Argyle Pattern Large	11: Independent Pattern (1 dot) 12: Independent Pattern (2 dot) 13: Independent Pattern (4 dot) 14: Trimming Area 15: Black Band (Horizontal) 16: Black Band (Vertical) 17: Checker Flag Pattern 18: Grayscale (Vertical) 19: Grayscale (Horizontal) 20: Full Dot Pattern 21: All White Pattern	
002	Test Pattern Density	ENG	[0 to 15 / 15 / 1 / step]

2201	[Development Bias Adjust] (D158/D159)		
	[Dv Bias Adj] (D160/D161/D170)		
	-		
001	Printing	*ENG	[-1500 to 0 / -550 / 10 V / step]
	Adjusts the voltage applied to the development roller for printing. Image density becomes higher when you specify a smaller value (a greater absolute value). Image density becomes lower when you specify a greater value (a smaller absolute value).		

002	P Pattern Revision (ID Sensor Pattern)	*ENG	[0 to 4 / 0 / 1 / step] 0: Normal 1: Drak 2: Light 3: Darker 4: Lighter
	Adjusts the voltage applied to the development roller for the ID sensor pattern. The voltage applied is obtained by adding SP2-201-002 to SP2-201-001. The setting affects ID sensor pattern density, which in turn affects the toner supply.		
003	ID Sensor Pattern (Temporally Input) (ID Pattern Voltage)	*ENG	[-700 to -300 / -350 / 10 V / step]
	Adjusts the voltage applied to the development roller when generating the ID sensor pattern. The actual voltage applied is this setting plus the value of SP2-201-001. The setting affects ID sensor pattern density, which in turn affects the toner supply.		

2210	[Bias Off Time] (D158/D159)		
	-		
001	Charge Bias	*ENG	[10 to 150 / 100 / 10 / step]
002	Development Bias	*ENG	[10 to 200 / 90 / 10 / step]

2211	[PCU Reverse Interval]		
	Stops printing and reverses PCU every sheets that has been set.		
001	PCU Reverse Int	*ENG	[0 to 999 / 100 / 1 sheet / step]

2213	[Copies After Toner Near End End Limits] (D158/D159)		
	Sets the number of copy/print pages that can be made after toner near-end has been detected. Reduce the number of pages if the user normally makes copies with a high image ratio.		
001	-	*ENG	[0 or 1 / 0 / 1 / step] 0: 50 sheets 1: 20 sheets

2213	[Outputs After NE] (D160/D161/D170)		
	[0 = 50 pages / 1 = 20 pages] Sets the number of copy/print/fax pages that can be made after toner near-end has been detected. Reduce the number of pages if the user normally makes copies with a high image ratio.		
001	-	*ENG	[0 or 1 / 0 / 1 / step]

2220	[Process Data Dilay] (D158/D159)		
	[ID Error Analysis] (D160/D161/D170)		
Displays:			
a) Vt: the current TD sensor output value and			
b) Vref: the target TD output value Vts (SP2-926) + correction for ID sensor output.			
The TD sensor output value changes every copy. If a > b, toner is supplied to the development unit.			
001	Vsp	*ENG	[0.00 to 9.99 / 0.00 / 0.01 vol / step]
002	Vsg	*ENG	[0.00 to 9.99 / 0.00 / 0.01 vol / step]
003	Vsdp	*ENG	[0.00 to 9.99 / 0.00 / 0.01 vol / step]
004	Vt	*ENG	[0.00 to 9.99 / 0.00 / 0.01 vol / step]
005	Vtref	*ENG	[0.00 to 9.99 / 2.5 / 0.01 vol / step]

2224	[Copies After Toner Near End] (D158/D159)		
	Current counter after near end.		
001	Counter	*ENG	[0 to 999 / 0 / 1 sheet / step]

2301	[Transfer Current Adjust] (D158/D159)		
	-		
001	Thin: 1 side: Image Area	*ENG	[-8 to 8 / 0 / 1 uA / step]
002	Thin: 1 side: Lead Edge	*ENG	[-8 to 8 / 0 / 1 uA / step]
003	Thin: 1 side: Trail Edge	*ENG	[-8 to 8 / 0 / 1 uA / step]

004	Thin:2side:Image Area	*ENG	[-8 to 8 / 0 / 1 uA / step]
005	Thin:2side:Lead Edge	*ENG	[-8 to 8 / 0 / 1 uA / step]
006	Thin:2side:Trail Edge	*ENG	[-8 to 8 / 0 / 1 uA / step]
007	Plain:1 side:Image Area	*ENG	[-8 to 8 / 0 / 1 uA / step]
008	Plain:1 side:Lead Edge	*ENG	[-8 to 8 / 0 / 1 uA / step]
009	Plain:1 side:Trail Edge	*ENG	[-8 to 8 / 0 / 1 uA / step]
010	Plain:2side:Image Area	*ENG	[-8 to 8 / 0 / 1 uA / step]
011	Plain:2side:Lead Edge	*ENG	[-8 to 8 / 0 / 1 uA / step]
012	Plain:2side:Trail Edge	*ENG	[-8 to 8 / 0 / 1 uA / step]
013	Middle:1 side:Image Area	*ENG	[-8 to 8 / 0 / 1 uA / step]
014	Middle:1 side:Lead Edge	*ENG	[-8 to 8 / 0 / 1 uA / step]
015	Middle:1 side:Trail Edge	*ENG	[-8 to 8 / 0 / 1 uA / step]
016	Middle:2side:Image Area	*ENG	[-8 to 8 / 0 / 1 uA / step]
017	Middle:2side:Lead Edge	*ENG	[-8 to 8 / 0 / 1 uA / step]
018	Middle:2side:Trail Edge	*ENG	[-8 to 8 / 0 / 1 uA / step]
019	Thick:1 side:Image Area	*ENG	[-8 to 8 / 0 / 1 uA / step]
020	Thick:1 side:Lead Edge	*ENG	[-8 to 8 / 0 / 1 uA / step]
021	Thick:1 side:Trail Edge	*ENG	[-8 to 8 / 0 / 1 uA / step]
022	Input:1 side	ENG	[0 to 30 / 0 / 1 uA / step]
023	Input:2side	ENG	[0 to 30 / 0 / 1 uA / step]
024	Non Image Area	*ENG	[0 to 30 / 10 / 1 uA / step]
025	Temp Inside The Machine	*ENG	[0 to 99 / 20 / 1 deg / step]

2301	[Tr Current Adj] (D160/D161/D170)		
	-		

001	Normal Paper	*ENG	[-2 to 2 / 0 / 1 / step]
	Adjusts the current applied to the transfer roller when feeding from a paper tray. Use a high setting if the user normally feeds relatively thick paper (within spec) from a paper tray.		
002	Thick/Special	*ENG	[-2 to 2 / 0 / 1 / step]
	Adjusts the current applied to the transfer roller when feeding from the by-pass tray. Use a high setting (a) if the user normally feeds relatively thick paper from the by-pass tray, or (b) if waste toner is re-attracted from the drum (which can occur when using transparencies).		
003	Duplex	*ENG	[-2 to 2 / 0 / 1 / step]
	Adjusts the current applied to the transfer roller when carrying out a duplex job. Use this SP if there is poor image transfer on the rear side of duplex copies.		
004	Cleaning/Negative	*ENG	[-10 to 1 / -4 / 1 uA/ step]
	Adjusts the current applied to the transfer roller for roller cleaning. Increase the current if toner remains on the roller after cleaning. (Remaining toner may cause dirty background on the rear side.)		
005	Cleaning/Positive	*ENG	[0 to 20 / 10 / 1 uA/ step]
006	Input/1side	*ENG	[0 to 30 / 0 / 1 uA/ step]
007	Input/2side	*ENG	[0 to 30 / 0 / 1 uA/ step]
008	Non Image Area	*ENG	[0 to 30 / 10 / 1 uA/ step]
009	Inside Temp	*ENG	[0 to 99 / 20 / 1 deg / step]

2302	[Transfer Switch Timing] (D158/D159)		
001	Lead Edge	*ENG	[-10 to 10 / 0 / 1 mm / step]
	Sets to change the image transfer electric current position that is based on the FGATE assert.		
002	Trail Edge	*ENG	[-10 to 10 / 0 / 1mm / step]
	Sets to change the image transfer off position that is based on the FGATE negation.		
2303	[Transfer Roller Cleaning Bias] (D158/D159)		

001	Positive	*ENG	[0 to 20 / 10 / 1 uA / step]
	Adjusts when backside contamination occurred that is caused by reverse polarity toner on the transfer roller or weak charging toner on the drum.		
002	Negative	*ENG	[0 to 20 / 4 / 1 -uA / step]
	Adjusts to improve the toner cleaning performance adhered on the transfer roller due to paper jamming etc...		

3

2401	[Special mode in low image] (D158/D159)		
	-		
001	Special mode in low image	*ENG	[0 to 3 / 0 / 1 / step]
	Switches the special mode in low image On / Off.		
002	Deterioration Threshold	*ENG	[0 to 200 / 21 / 1 cm ² /m / step]
	Threshold of image area per running distance to determine the degree of degradation.		
003	Deterioration Coverage Sum	*ENG	[0 to 30000 / 0 / 1 cm ² / step]
	Accumulates the difference between the image area of the actual image forming operation and threshold (x running distance) set by SP2-401-002.		
004	Deterioration Coverage Sum Threshold	*ENG	[0 to 30000 / 18700 / 1 cm ² / step]
	Controls special mode in low image when this value is reached more than SP2-401-003.		
005	Charge Bias Correction	*ENG	[-300 to 0 / -50 / 10 vol / step]
	Adds this value to SP2-001-001 (the controlling value of the normal charging voltage) when controlling the toner adhesion amount control.		
006	Development Bias Correction	*ENG	[-300 to 0 / -50 / 10 vol / step]
	Adds this value to SP2-201-001 (the controlling value of the normal development voltage) when controlling the toner adhesion amount control.		

2401	[Separation Voltage] (D160/D161/D170)		
	-		
001	1 side/Lead Edge	*ENG	[-4000 to 0 / 0 / 10 V / step]

002	1side/Image Area	*ENG	[-4000 to 0 / 0 / 10 V / step]
003	2side/Lead Edge	*ENG	[-4000 to 0 / 0 / 10 V / step]
004	2side/Image Area	*ENG	[-4000 to 0 / 0 / 10 V / step]
005	Switching Timing	*ENG	[-20 to 20 / 15 / 1 mm / step]

2801	[Developer Initialization] (D158/D159) [Devlpr Initialize] (D160/D161/D170)		
001	Standard Speed (Devlpr Initialize)	ENG	[- / - / -] [Execute]
Executes developer initialization when new PCU is replaced.			

2802	[Developer Mixing] (D158/D159) [Force DevlpChurn] (D160/D161/D170)		
001	-	ENG	[- / - / -] [Execute]
Initializes the developer and checks the TD sensor output (Vt). The machine mixes the developer for 2 minutes while reading and displaying the Vt value. The machine does not initialize the TD sensor output. If the machine has not been used for a long period, prints may have a dirty background. In a case like this, use this SP to mix the developer. The message "Completed" is displayed when the program ends normally.			

2803	[Developer Initialization Date] (D158/D159)		
001	Vtref	*ENG	[0.00 to 9.99 / 2.50 / 0.01 vol / step]
Vtref value at the completion of the initial agent configuration			
002	ID Sensor PWM Value	*ENG	[0 to 1023 / 0 / 1 /step]
ID sensor PWM value at the time of completion of the initial agent configuration			

2901	[Separation Voltage Adjust] (D158/D159)		
001	1side:Lead Edge	*ENG	[0 to 4000 / 0 / 100 -V / step]
Used to improve the separation of the 1side.			

002	1side:Image Area	*ENG	[0 to 4000 / 0 / 100 -V / step]
	Used to improve the separation of the 1 side, the improvement of dust.		
003	2side:Lead Edge	*ENG	[0 to 4000 / 0 / 100 -V / step]
	Used to improve the separation of the 2side.		
004	2side:Image Area	*ENG	[0 to 4000 / 0 / 100 -V / step]
	Used to improve the separation of the 2side, the improvement of dust.		
005	Switch Lead Edge Timing	*ENG	[-20 to 20 / 15 / 1 mm / step]
	Set when you want to change the position of the image separation bias based on the assertion FGATE.		

2906	[Tailing Control Number of Sheets] (D158/D159)		
	[Tailing Crctn] (D160/D161/D170)		
001	Shift Value (D160/D161/ D170)	*ENG	[0.0 to 10.0 / 0.0 / 0.1 mm / step]
	Shifts the image position at the intervals specified by SP2-906-002. When the copier is continuously printing vertical lines (such as in tables), the paper may not separate correctly. This SP can prevent this.		
002	Number of Sheets (Interval)	ENG	D158/D159: [0 to 10 / 0 / 1 sheet / step] D160/D161/D170: [1 to 10 / 1 / 1 sheet / step]
	Changes the interval of the image position shift specified by SP2-906-001.		

2908	[Forced Toner Supply] (D158/D159)		
	[Force Toner Supp] (D160/D161/D170)		

	Number of Sheets (Force Toner Supp)	ENG	[- / - / -] [Execute]
001	Supplies the toner to the development unit. The processing stops under either of the following conditions: <ul style="list-style-type: none"> The toner density in the development unit reaches the standard level. The processing has continued for 2 minutes. 		

2915	[Polygon Rotate Timing] (D158/D159)		
001	Idling Time ADJ	*ENG	[0 to 60 / 15 / 1 sec / step]
	Adjusts the polygon motor idling time.		
002	Post Idling Time ADJ	*ENG	[0 to 60 / 15 / 1 sec / step]
	Adjusts the post idling time		

2915	[Polygon Idling] (D160/D161/D170)		
001	Polygon Idling	*ENG	[0 to 2 / 1 / 1 / step]
	Adjusts the polygon motor idling time.		

2921	[Toner Supply Mode]		
001	Mode Select (Toner Supply Mode)	*ENG	[0 to 3 / 0 / 1 / step]
	0:Normal1 1:Normal2 2:Fixed1 3:Fixed2		

2922	[Toner Supply Time [sec]] (D158/D159) [Toner Supply Time] (D160/D161/D170)		
	Adjusts the toner supply time. The toner supply motor remains on for the specified time. To validate this setting, select "0" in SP2-921-001. Specify a greater value if the user tends to make many copies having high proportions of solid black image areas.		

001	-	*ENG	[0.1 to 5.0 / 0.4 / 0.1 / step]
2923	[Toner Recovery Time] (D158/D159) [Toner Recovery] (D160/D161/D170)		
	Sets the toner recovery time.		
001	-	*ENG	D158/D159: [1 to 60 / 30 / 1 sec / step] D160/D161/D170: [3 to 60 / 30 / 1 sec / step]
2925	[Toner Supply Ratio] (D158/D159) [Toner Supply Rate] (D160/D161/D170)		
	0: x1 1: x2 2: x4 3: x8 4: x12 5: x16 6: Continuation 7: Not Supply		
001	Ratio Select (Toner Supply Rate)	*ENG	[0 to 7 / 0 / 1 / step]
2926	[Standard Vt] DFU		
	Sets reference value of T sensor control to control toner density. This SP clears SP2-224-001: Copies After Toner Near End		
001	-	*ENG	[0.00 to 5.00 / D158/D159:2.50, D160/D161/D170:2.40 / 0.05 vol / step]

2927	[ID Sensor Control Function Select] (D158/D159)		
	[ID Sensor Control] (D160/D161/D170)		
	Determines whether the ID sensor signal is referenced or not for the toner density control. Keep the default value in usual operations.		
001	0: Off , 1: On (ID Sensor Control)	ENG	[0 or 1 / 1 / 1 / step] 0: Correction Off 1: Correction On
2928	[Toner End Clear]		
	Clears the following messages and counters without supplying the toner: <ul style="list-style-type: none"> • Toner near end message • Toner end message • Toner near end counter • Toner end counter Do not use this SP in usual operations. When the toner in the development unit is abnormally insufficient, the drum may attract the toner carrier to its surface. The toner carrier might damage the drum surface.		
001	0: Off , 1: On (Toner End Clear)	ENG	[0 or 1 / 0 / 1 / step]
2929	[Vref Adjustment] (D158/D159)		
	[Vtref Limits] (D160/D161/D170)		
	Adjust the upper or lower Vref limit.		
001	Upper Limit (Upper)	*ENG	[0.50 to 3.50 / D158/D159:2.80, D160/D161/D170:2.45 / 0.05 vol / step]
002	Lower Limit (Lower)	*ENG	[0.50 to 3.50 / D158/D159:1.4, D160/D161/D170:1.25 / 0.05 vol / step]
2930	[TD Sensor Manual Setting] (D158/D159)		
	Manually enters Vtref value. SP2-926-001 will be disabled when this SP is set.		

001	-	*ENG	[0.00 to 5.00 / 0.00 / 0.05 vol / step]
2931	[TD (V/ wt%) Setting]		
	Sets the toner supply ease.		
001	[V/ wt%]	*ENG	[0.01 to 1.50 / 0.40 / 0.01 / step]
2932	[Toner Density Control Level] (D158/D159) [Toner Density Adj] (D160/D161/D170)		
	Enables when SP2-921-001 (the toner supply mode) is set to "1: Normal2". 0:Normal 1:Dark 2:Light 3:Darker 4:Lighter		
001	Level Select	*ENG	[0 to 4 / 0 / 1 / step]
2933	[ID Sensor Control Correction] (D158/D159) [ID Sensor Adj] (D160/D161/D170)		
	Adjusts the correction value for P sensor. This SP is design use only and do not change.		
001	-	*ENG	[0.0 to 3.0 / 1.0 / 0.1 / step]
2934	[ID Sensor PWM Setting] (D158/D159) [ID Error Analysis] (D160/D161/D170)		
	001	Dilay (PWM)	*ENG
003	Displays ID Sensor PWM value.		
	Upper Limit Correction	*ENG	[0 to 1023 / 100 / 1 / step]
Upper limit value of ID sensor PMW.			

2935	[ID Sensor Initialization] (D158/D159)		
	Executes ID Sensor initialization. It must be done after replacing the ID sensor. This SP clears PWM value and executes Vsg adjustment again, then resets PWM value.		
001	-	ENG	[0 or 1 / 0 / 1 / step]
2936	[ID Sensor Detection Interval] (D158/D159)		
	[ID Sensor Detection] (D160/D161/D170)		
Counts every page printed. If this counter reached the number set in SP9-995-002, interrupt the print job and do the process set in SP2-995-003.			
001	Counter	*ENG	[0 to 999 / 0 / 1 page / step]
2992	[After ID Sensor Error] (D158/D159)		
	Displays SC after the limit number of copies printed when ID sensor error is occurred.		
001	Copies Limit	*ENG	[0 or 1 / 0 / 1 / step] 0: 100 1: 200
2995	[ID Sensor Detection] (D158/D159)		
001	Interval Warming-up	*ENG	[0 to 999 / 480 / 1 min / step]
	Performs ID sensor warmup after recovering from energy-saving mode when the machine stayed energy-saving mode more than specified time.		
002	Interval Number of Pages	*ENG	[0 to 999 / 100 / 1 sheet / step]
	Interrupts printing jobs and performs the process set in SP2-995-003 when this number reached SP2-936-001.		
003	Effect Timing	*ENG	[0 or 1 / 0 / 1 / step]
	0:Job End 1:Interrupt		
	Sets executing timing of ID sensor controlling.		

2995	[ID Detect Temp] (D160/D161/D170)		
	-		
001	ID Detect Temp	*ENG	[30 to 90 / 30 / 1 deg/ step]
002	Number of Pages	*ENG	[0 to 999 / 100 / 1 sheet / step]
003	JobEnd/Interrupt	*ENG	[0 or 1 / 0 / 1 / step]

2996	[Transfer Roller Cleaning] (D158/D159)		
	[T Roller Cleaning] (D160/D161/D170)		
001	Function Select (T Roller Cleaning)	*ENG	[0 or 1 / 0 / 1 / step] 0: Off 1: On
	Selects the transfer roller cleaning before printing On / Off.		
002	Interval	*ENG	[0 to 100 / 50 / 1 / step]
	Executes the transfer roller cleaning after job end when the counter (SP2-996-003) reached this SP.		
003	Counter	ENG	[0 to 255 / 0 / 1 sheet / step]
	Counter for executing SP2-996-002. Counts up when registration is resumed.		

2998	[PCU Reverse Rotation Time] (D158/D159)		
001	Wait Time	*ENG	[240 to 999 / 300 / 1 ms / step]
	Sets the time until the reverse rotation starts after the main motor stopped.		
002	Reverse Time	*ENG	[0 to 99 / 60 / 1 ms / step]
	Sets the reverse rotation time.		

2998	[Main Mag-print] (D160/D161/D170)		
001	Main Mag-print	*ENG	[-5.0 to 5.0 / 0.0 / 0.1 % / step]
	Adjusts the magnification for the main scanning direction.		

2999	[Main Motor Adj] (D160/D161/D170)		
-------------	--	--	--

001	Wait Time	*ENG	[-5.0 to 5.0 / 0.0 / 0.1 % / step]
002	Reverse Time	*ENG	[0 to 99 / 60 / 1 ms / step]

Main SP Tables-3

SP3-XXX (Process)

There are no Group 3 SP modes for this machine.

Main SP Tables-4

SP4-XXX (Scanner)

4008	[Sub Scan Magnification Adj] (D158/D159)		
	[Sub Scan Mag] (D160/D161/D170)		
Adjusts the sub-scan magnification by changing the scanner motor speed.			
001	-	ENG	D158/D159: [-1.0 to 1.0 / 0.0 / 0.1 % / step] D160/D161/D170: [-9.0 to 9.0 / 0.0 / 0.1 % / step]
4009	[Main Scan Mag] (D160/D161/D170)		
	Adjusts the main-scan magnification by using the zooming function of IPU.		
001	-	ENG	[-10 to 10 / 0.0 / 0.1 % / step]
4010	[Sub Scan Registration Adj] (D158/D159)		
	[LE Scan Regist] (D160/D161/D170)		
Adjusts the leading edge registration for scanning.			
001	-	ENG	D158/D159: [-2.0 to 2.0 / 0.0 / 0.1 mm / step] D160/D161/D170: [-10.0 to 10.0 / 0.0 / 0.1 mm / step]
4011	[Main Scan Reg] (D158/D159)		
	[StoS Scan Regist] (D160/D161/D170)		
Adjusts the side-to-side registration by changing the scanning start timing in the main scan direction.			
001	-	ENG	[-2.5 to 2.5 / 0.0 / 0.1 mm / step]

4012	<p>[Set Scale Mask] (D158/D159)</p> <p>[Scan Erase Margin] (D160/D161/D170)</p>		
	<p>Adjusts scanning margins for the leading and trailing edges (sub scan) and right and left edge (main scan).</p> <p>Note</p> <ul style="list-style-type: none"> Do not adjust unless the customer desires a scanner margin greater than the printer margin. These settings are adjusted to erase shadows caused by the gap between the original and the scale of the scanner unit. 		
001	Book: Sub Ledge (Leading Edge)	ENG	<p>D158/D159 [0.0 to 3.0 / 1.0 / 0.1 mm / step]</p> <p>D160/D161/D170 [0.0 to 9.0 / 1.0 / 0.1 mm / step]</p>
002	Book: Sub TEdge (Trailing Edge)	ENG	<p>D158/D159 [0.0 to 3.0 / 0.0 / 0.1 mm / step]</p> <p>D160/D161/D170 [0.0 to 9.0 / 1.0 / 0.1 mm / step]</p>
003	Book: Main Ledge (Left Side)	ENG	<p>D158/D159 [0.0 to 3.0 / 1.0 / 0.1 mm / step]</p> <p>D160/D161/D170 [0.0 to 9.0 / 1.0 / 0.1 mm / step]</p>
004	Book: Main TEdge (Right Side)	ENG	<p>D158/D159 [0.0 to 3.0 / 0.0 / 0.1 mm / step]</p> <p>D160/D161/D170 [0.0 to 9.0 / 1.0 / 0.1 mm / step]</p>
005	Scale ADF: Leading Edge (D158/D159)	*ENG	[0.0 to 3.0 / 0.0 / 0.1 mm / step]
007	Scale ADF: Right (D158/ D159)	*ENG	[0.0 to 3.0 / 0.0 / 0.1 mm / step]
008	Scale ADF: left (D158/ D159)	*ENG	[0.0 to 3.0 / 0.0 / 0.1 mm / step]

4013	[Scanner Free Run]		
	Performs a scanner free run with the exposure lamp on or off.		
001	Book mode: Lamp Off (Scanner Free Run)	ENG	[0 or 1 / 0 / 1 / step] 0:OFF, 1:ON
002	Book mode: Lamp On (D158/D159)	ENG	[0 or 1 / 0 / 1 / step] 0:OFF, 1:ON

4014	[Scan] (D158/D159)		
	Executes the scanner free run with each mode.		
001	HP Detection Enable	ENG	[0 or 1 / 0 / 1 / step] 0:OFF, 1:ON
002	HP Detection Disable	ENG	[0 or 1 / 0 / 1 / step] 0:OFF, 1:ON

4020	[Dust Check] (D158/D159)		
	-		
001	Dust Detection:On/Off	*ENG	[0 or 1 / 0 / 1 / step] 0: OFF, 1: ON
002	Dust Detect: Lvl	*ENG	Selects the detect level. [0 to 8 / 4 / 1 / step] 0: lowest detection level 8: highest detection level
003	Dust Reject: Lvl	*ENG	Selects the level. [0 to 4 / 0 / 1 / step]

4301	[Operation Check] (D158/D159)		
	[Display-APS Data] (D160/D161/D170)		
Displays the size detected by APS Sensor which is in the scanner unit.			

001	APS Sensor (Display-APS Data)	ENG	D158/D159 [0 to 255 / 0 / 1 / step] D160/D161/D170 [0 to 0xFFFF / 0 / 1 / step]
-----	-------------------------------	-----	--

4303	[Min Size for APS] (D158/D159) [APS Small Origin] (D160/D161/D170)		
	Determines whether an original of non-standard size is detected as A5/HLT size by the APS sensor.		
001	-	*ENG	[0 to 2 / 0 / 1 / step] 0: No original 1: HLT SEF(US), A5 SEF(The other) 2: HLT LEF(US), A5 LEF(The other)

4305	[8K/16K Detection] (D158/D159)		
	0: Normal Detection 1: A4-Sideways LT-Lengthwise 2: LT-Sideways A4-Lengthwise 3: 8K 16K		
001	Detection ON/OFF	*ENG	[0 to 3 / 0 / 1 / step]

4305	[APS Priority] (D160/D161/D170)		
	0: Normal Detection 1: LT SEF LEF - A4 SEF LEF(US) A4 SEF LEF - LT SEF LEF(Except US/CHN) A3 SEF,B4 SEF – 8K SEF(CHN) A4 SEF,B5 SEF – 16K SEF(CHN) A4 LEF,B5 LEF – 16K LEF(CHN)		
001	-	*ENG	[0 to 1 / 0 / 1 / step]

4308	[Scan Size Detection] (D158/D159)		
	Selects whether the machine detects the scan size. 0:OFF 1:ON 2:APS		
001	Detection ON/OFF	*ENG	[0 to 2 / 1 / 1 / step]

4309	[Scan Size Detect:Setting] (D158/D159)		
001	Original Density Thresh	*ENG	[0 to 255 / 18 / 1 digit / step]
	Adjusts the density for the scan size detection.		
002	Detection Time	*ENG	[20 to 100 / 60 / 20 msec / step]
	Adjusts the detection time for scan size detection.		
003	Lamp ON:Delay Time	*ENG	[40 to 200 / 40 / 10 msec / step]
	Adjusts the timing when to lamp on for the scan size detection.		
004	LED PWM Duty	*ENG	[0 to 100 / 60 / 1 / step]
	Adjusts the light value for the scan size detection.		

4310	[Scan Size Detect Value] (D158/D159)		
	Checks the density of scanning data for the scan size detection.		
001	S1:R	ENG	[0 to 255 / 0 / 1 digit / step]
002	S1:G	ENG	[0 to 255 / 0 / 1 digit / step]
003	S1:B	ENG	[0 to 255 / 0 / 1 digit / step]
004	S2:R	ENG	[0 to 255 / 0 / 1 digit / step]
005	S2:G	ENG	[0 to 255 / 0 / 1 digit / step]
006	S2:B	ENG	[0 to 255 / 0 / 1 digit / step]
007	S3:R	ENG	[0 to 255 / 0 / 1 digit / step]
008	S3:G	ENG	[0 to 255 / 0 / 1 digit / step]

009	S3:B	ENG	[0 to 255 / 0 / 1 digit / step]
-----	------	-----	---------------------------------

4350	[Intermittent Shading: B/W] (D158/D159)		
001	Switch On/Off	ENG	[0 or 1 / 1 / 1 / step]
002	Interval 1	ENG	[0 to 65535 / 180 / 1 sec / step]
003	Interval 1 Times	ENG	[1 to 60 / 1 / 1 / step]
004	Interval 2	ENG	[0 to 65535 / 180 / 1 sec / step]

4350	[ADF Shading Time] (D160/D161/D170)		
	-		
001	ADF Shading Time	*ENG	[0 to 90 / 60 / 1 sec / step]

4351	[Intermittent Shading: Color] (D158/D159)		
	-		
001	Switch On/Off	ENG	[0 or 1 / 1 / 1 / step]
002	Interval 1	ENG	[0 to 65535 / 180 / 1 sec / step]
003	Interval 1 Times	ENG	[1 to 60 / 1 / 1 / step]
004	Interval 2	ENG	[0 to 65535 / 180 / 1 sec / step]

4400	[Org Edge Mask] (D158/D159)		
	Sets the Mask for Original. These SPs set the area to be masked during platen (book) mode scanning.		
001	Book: Sub:LEdge	ENG	[0.0 to 3.0 / 0.0 / 0.1 mm / step]
002	Book: Sub:TEdge	ENG	[0.0 to 3.0 / 0.0 / 0.1 mm / step]
003	Book: Main:LEdge	ENG	[0.0 to 3.0 / 0.0 / 0.1 mm / step]
004	Book: Main:TEdge	ENG	[0.0 to 3.0 / 0.0 / 0.1 mm / step]

4400	[Scanner Erase Margin] (D158/D159)		
	Sets the Mask for Original. These SPs set the area to be masked during ADF mode scanning.		
005	ADF: Leading Edge	*ENG	[0.0 to 3.0 / 0.0 / 0.1 mm / step]
007	ADF: Right	*ENG	[0.0 to 3.0 / 0.0 / 0.1 mm / step]
008	ADF: Left	*ENG	[0.0 to 3.0 / 0.0 / 0.1 mm / step]

4417	[IPU Test Pattern] (D158/D159)		
	Selects the IPU test pattern.		
001	Test Pattern	ENG	[0 to 8 / 0 / 1 / step]
	-		
0	Scanned image	5	Slant grid pattern C
1	Gradation main scan A	6	Slant grid pattern D
2	Patch 16C	7	Scanned+Slant Grid C
3	Grid pattern A	8	Scanned+Slant Grid D
4	Slant grid pattern B	-	

4429	[Select Copy Data Security] (D158/D159)		
	Adjusts the pattern density of illegal copy output for Copy, Scanner, and Fax.		
001	Copying	*ENG	[0 to 3 / 3 / 1 / step] 3: Darkest density
002	Scanning	*ENG	
003	Fax Operation	*ENG	

4450	[Scan Image Pass Selection] (D158/D159)		
	[Image Path] (D160/D161/D170)		
001	Black Subtraction ON/OFF (BK Offset Enable)	ENG	[0 or 1 / 1 / 1 / step] 0: OFF, 1: ON
	Uses or does not use the black reduction image path.		

002	SH ON/OFF (SH Pass Enable)	ENG	D158/D159 [0 or 1 / 0 / 1 / step] D160/D161/D170 [0 or 1 / 0 / 1 / step] 0: OFF, 1: ON
	Uses or does not use the shading image path.		

3

4460	[Digital AE] (D158/D159)		
	Adjusts the background level.		
001	Lower Limit:Value	*ENG	[0 to 1023 / 364 / 1 / step]
002	Background Level	*ENG	[512 to 1535 / 932 / 1 / step]

4550	[Scan Apli:Txt/Print] (D158/D159)		
	Sets the text/print MTF level of the scanner application.		
005	MTF: 0(Off) 1-15 (Weak-Strong)	*ENG	[0 to 15 / 8 / 1 / step]
006	Smoothing: 0(x1) 1-7 (Weak-Strong)	*ENG	[0 to 7 / 4 / 1 / step]
007	Brightness: 1-255	*ENG	[1 to 255 / 128 / 1 / step]
008	Contrast: 1-255	*ENG	[1 to 255 / 128 / 1 / step]
009	Ind Dot Erase: 0(Off) 1-7 (Weak-Strong)	*ENG	[0 to 7 / 0 / 1 / step]

4551	[Scan Apli:Txt] (D158/D159)		
	Sets the text MTF level of the scanner application.		
005	MTF: 0(Off) 1-15 (Weak-Strong)	*ENG	[0 to 15 / 8 / 1 / step]
006	Smoothing: 0(x1) 1-7 (Weak-Strong)	*ENG	[0 to 7 / 4 / 1 / step]
007	Brightness: 1-255	*ENG	[1 to 255 / 128 / 1 / step]

008	Contrast: 1-255	*ENG	[1 to 255 / 128 / 1 / step]
009	Ind Dot Erase: 0(Off) 1-7 (Weak-Strong)	*ENG	[0 to 7 / 0 / 1 / step]

4552	[Scan Apli:Txt Dropout] (D158/D159)		
	Sets the text dropout color MTF level of the scanner application.		
005	MTF: 0(Off) 1-15 (Weak-Strong)	*ENG	[0 to 15 / 8 / 1 / step]
006	Smoothing: 0(x1) 1-7 (Weak-Strong)	*ENG	[0 to 7 / 4 / 1 / step]
007	Brightness: 1-255	*ENG	[1 to 255 / 128 / 1 / step]
008	Contrast: 1-255	*ENG	[1 to 255 / 128 / 1 / step]
009	Ind Dot Erase: 0(Off) 1-7 (Weak-Strong)	*ENG	[0 to 7 / 0 / 1 / step]

4553	[Scan Apli:Txt/Photo] (D158/D159)		
	Sets the text/photo MTF level of the scanner application.		
005	MTF: 0(Off) 1-15 (Weak-Strong)	*ENG	[0 to 15 / 8 / 1 / step]
006	Smoothing: 0(x1) 1-7 (Weak-Strong)	*ENG	[0 to 7 / 4 / 1 / step]
007	Brightness: 1-255	*ENG	[1 to 255 / 128 / 1 / step]
008	Contrast: 1-255	*ENG	[1 to 255 / 128 / 1 / step]
009	Ind Dot Erase: 0(Off) 1-7 (Weak-Strong)	*ENG	[0 to 7 / 0 / 1 / step]

4554	[Scan Apli:Photo] (D158/D159)		
	Sets the photo MTF level of the scanner application.		
005	MTF: 0(Off) 1-15 (Weak-Strong)	*ENG	[0 to 15 / 8 / 1 / step]

006	Smoothing: 0(x1) 1-7 (Weak-Strong)	*ENG	[0 to 7 / 4 / 1 / step]
007	Brightness: 1-255	*ENG	[1 to 255 / 128 / 1 / step]
008	Contrast: 1-255	*ENG	[1 to 255 / 128 / 1 / step]
009	Ind Dot Erase: 0(Off) 1-7 (Weak-Strong)	*ENG	[0 to 7 / 0 / 1 / step]

4565	[Scan Apli:GrayScale] (D158/D159)		
	Sets the Grayscale MTF level of the scanner application.		
005	MTF: 0(Off) 1-15 (Weak-Strong)	*ENG	[0 to 15 / 8 / 1 / step]
006	Smoothing: 0(x1) 1-7 (Weak-Strong)	*ENG	[0 to 7 / 4 / 1 / step]
007	Brightness: 1-255	*ENG	[1 to 255 / 128 / 1 / step]
008	Contrast: 1-255	*ENG	[1 to 255 / 128 / 1 / step]
009	Ind Dot Erase: 0(Off) 1-7 (Weak-Strong)	*ENG	[0 to 7 / 0 / 1 / step]

4570	[Scan Apli:Col Txt/Photo] (D158/D159)		
	Sets the color text/photo MTF level of the scanner application.		
005	MTF: 0(Off) 1-15 (Weak-Strong)	*ENG	[0 to 15 / 8 / 1 / step]
006	Smoothing: 0(x1) 1-7 (Weak-Strong)	*ENG	[0 to 7 / 4 / 1 / step]
007	Brightness: 1-255	*ENG	[1 to 255 / 128 / 1 / step]
008	Contrast: 1-255	*ENG	[1 to 255 / 128 / 1 / step]
009	Ind Dot Erase: 0(Off) 1-7 (Weak-Strong)	*ENG	[0 to 7 / 0 / 1 / step]

4571	[Scan Apli:Col Gloss Photo] (D158/D159)		
	Sets the color gloss photo MTF level of the scanner application.		
005	MTF: 0(Off) 1-15 (Weak-Strong)	*ENG	[0 to 15 / 8 / 1 / step]
006	Smoothing: 0(x1) 1-7 (Weak-Strong)	*ENG	[0 to 7 / 4 / 1 / step]
007	Brightness: 1-255	*ENG	[1 to 255 / 128 / 1 / step]
008	Contrast: 1-255	*ENG	[1 to 255 / 128 / 1 / step]
009	Ind Dot Erase: 0(Off) 1-7 (Weak-Strong)	*ENG	[0 to 7 / 0 / 1 / step]

4572	[Scan Apli:AutoCol] (D158/D159)		
	Sets the automatic color MTF level of the scanner application.		
005	MTF: 0(Off) 1-15 (Weak-Strong)	*ENG	[0 to 15 / 8 / 1 / step]
006	Smoothing: 0(x1) 1-7 (Weak-Strong)	*ENG	[0 to 7 / 4 / 1 / step]
007	Brightness: 1-255	*ENG	[1 to 255 / 128 / 1 / step]
008	Contrast: 1-255	*ENG	[1 to 255 / 128 / 1 / step]
009	Ind Dot Erase: 0(Off) 1-7 (Weak-Strong)	*ENG	[0 to 7 / 0 / 1 / step]

4580	[Fax Apli:Txt/Chart] (D158/D159)		
	Sets the text/chart MTF level of the fax application.		
005	MTF: 0(Off) 1-15 (Weak-Strong)	*ENG	[0 to 15 / 8 / 1 / step]
006	Smoothing: 0(x1) 1-7 (Weak-Strong)	*ENG	[0 to 7 / 4 / 1 / step]
007	Brightness: 1-255	*ENG	[1 to 255 / 128 / 1 / step]
008	Contrast: 1-255	*ENG	[1 to 255 / 128 / 1 / step]

009	Ind Dot Erase: 0(Off) 1-7 (Weak-Strong)	*ENG	[0 to 7 / 0 / 1 / step]
010	Texture Erase: 0 (Fix), 1-2	*ENG	[0 to 2 / 0 / 1 / step]

4581	[Fax Apli:Txt] (D158/D159)		
	Sets the text MTF level of the fax application.		
005	MTF: 0(Off) 1-15 (Weak-Strong)	*ENG	[0 to 15 / 8 / 1 / step]
006	Smoothing: 0(x1) 1-7 (Weak-Strong)	*ENG	[0 to 7 / 4 / 1 / step]
007	Brightness: 1-255	*ENG	[1 to 255 / 128 / 1 / step]
008	Contrast: 1-255	*ENG	[1 to 255 / 128 / 1 / step]
009	Ind Dot Erase: 0(Off) 1-7 (Weak-Strong)	*ENG	[0 to 7 / 0 / 1 / step]

4582	[Fax Apli:Txt/Photo] (D158/D159)		
	Sets the text/photo MTF level of the fax application.		
005	MTF: 0(Off) 1-15 (Weak-Strong)	*ENG	[0 to 15 / 8 / 1 / step]
006	Smoothing: 0(x1) 1-7 (Weak-Strong)	*ENG	[0 to 7 / 4 / 1 / step]
007	Brightness: 1-255	*ENG	[1 to 255 / 128 / 1 / step]
008	Contrast: 1-255	*ENG	[1 to 255 / 128 / 1 / step]
009	Ind Dot Erase: 0(Off) 1-7 (Weak-Strong)	*ENG	[0 to 7 / 0 / 1 / step]
010	Texture Erase: 0 (Fix), 1-2	*ENG	[0 to 2 / 0 / 1 / step]

4583	[Fax Apli:Photo] (D158/D159)		
	Sets the photo MTF level of the fax application.		

005	MTF: 0(Off) 1-15 (Weak-Strong)	*ENG	[0 to 15 / 8 / 1 / step]
006	Smoothing: 0(x1) 1-7 (Weak-Strong)	*ENG	[0 to 7 / 4 / 1 / step]
007	Brightness: 1-255	*ENG	[1 to 255 / 128 / 1 / step]
008	Contrast: 1-255	*ENG	[1 to 255 / 128 / 1 / step]
009	Ind Dot Erase: 0(Off) 1-7 (Weak-Strong)	*ENG	[0 to 7 / 0 / 1 / step]
010	Texture Erase: 0 (Fix), 1-2	*ENG	[0 to 2 / 0 / 1 / step]

4584	[Fax Apli:Original 1] (D158/D159)		
	Sets the original 1 MTF level of the fax application.		
005	MTF: 0(Off) 1-15 (Weak-Strong)	*ENG	[0 to 15 / 8 / 1 / step]
006	Smoothing: 0(x1) 1-7 (Weak-Strong)	*ENG	[0 to 7 / 4 / 1 / step]
007	Brightness: 1-255	*ENG	[1 to 255 / 128 / 1 / step]
008	Contrast: 1-255	*ENG	[1 to 255 / 128 / 1 / step]
009	Ind Dot Erase: 0(Off) 1-7 (Weak-Strong)	*ENG	[0 to 7 / 0 / 1 / step]

4585	[Fax Apli:Original 2] (D158/D159)		
	Sets the original 2 MTF level of the fax application.		
005	MTF: 0(Off) 1-15 (Weak-Strong)	*ENG	[0 to 15 / 8 / 1 / step]
006	Smoothing: 0(x1) 1-7 (Weak-Strong)	*ENG	[0 to 7 / 4 / 1 / step]
007	Brightness: 1-255	*ENG	[1 to 255 / 128 / 1 / step]
008	Contrast: 1-255	*ENG	[1 to 255 / 128 / 1 / step]

009	Independent Dot Erase (0)/ 1-7 (Strong)	*ENG	[0 to 7 / 0 / 1 / step]
-----	--	------	-------------------------

4600	[SBU Version Display] (D158/D159)		
	-		
001	SBU ID	ENG	[0x00 to 0xFF / 0 / 1 / step]
002	SCAT ID	ENG	[0x00 to 0xFF / 0 / 1 / step]

4602	[Scanner Memory Access] (D158/D159)		
	Enables the read and write check for the SBU registers.		
001	Scanner Memory Access	ENG	[0x00000000 to 0xFFFFFFFF / 0x00000000 / - / step]

4603	[Auto Adjustment Operation] (D158/D159)		
	Executes the AGC and enables the home position detection.		
001	HP Detection Enable	ENG	[0 or 1 / 0 / 1 / step]
002	HP Detection Disable	ENG	[0 or 1 / 0 / 1 / step]

4603	[Force AGC] (D160/D161/D170)		
	-		
001	Force AGC	ENG	[0 or 1 / 0 / 1 / step]

4604	[FGATE Open/Close] (D158/D159)		
	Opens or closes the FGATE		
001	FGATE Open/Close	ENG	[0 or 1 / 0 / 1 / step] 0:OFF, 1:ON

4609	[Gray Balance Set: R]		
	Displays the adjustment value of the gray balance for red.		

001	Book Scan	*ENG	D158/D159 [-384 to 255 / -100 / 1 digit / step] D160/D161/D170 [128 to 383 / 256 / 1 / step]
002	DF Scan	*ENG	D158/D159 [-384 to 255 / -100 / 1 digit / step] D160/D161/D170 [128 to 383 / 256 / 1 / step]

3

4610	[Gray Balance Set: G]		
	Displays the adjustment value of the gray balance for green.		
001	Book Scan	*ENG	D158/D159 [-384 to 255 / -100 / 1 digit / step] D160/D161/D170 [128 to 383 / 256 / 1 / step]
002	DF Scan	*ENG	D158/D159 [-384 to 255 / -100 / 1 digit / step] D160/D161/D170 [128 to 383 / 256 / 1 / step]

4610	[Gray Balance Set: BW] (D160/D161/D170)		
	Displays the adjustment value of the gray balance for BW		
003	Book Scan	*ENG	[128 to 383 / 256 / 1 / step]
004	DF Scan	*ENG	[128 to 383 / 256 / 1 / step]

4611	[Gray Balance Set: B]		
	Displays the adjustment value of the gray balance for blue.		

001	Book Scan	*ENG	D158/D159 [-384 to 255 / -100 / 1 digit / step] D160/D161/D170 [128 to 383 / 256 / 1 / step]
002	DF Scan	*ENG	D158/D159 [-384 to 255 / -100 / 1 digit / step] D160/D161/D170 [128 to 383 / 256 / 1 / step]

4623	[Black Level Adj] (D160/D161/D170)		
	-		
001	Latest:RCL_DAC	ENG	[0 to 15 / 0 / 1 / step]
002	Latest:OFFSET_DAC	ENG	[0 to 255 / 0 / 1 / step]

4635	[SSCG Corection] DFU (D158/D159)		
	-		
001	Set Mode Selection	*ENG	[0 to 3 / 1 / 1 / step]

4637	[SSCG Corection Value (Ana.)] DFU (D158/D159)		
	-		
001	Latest: RE	ENG	[-31 to 31 / 0 / 1 digit / step]
002	Latest: RO	ENG	[-31 to 31 / 0 / 1 digit / step]
003	Latest: GE	ENG	[-31 to 31 / 0 / 1 digit / step]
004	Latest: GO	ENG	[-31 to 31 / 0 / 1 digit / step]
005	Latest: BE	ENG	[-31 to 31 / 0 / 1 digit / step]
006	Latest: BO	ENG	[-31 to 31 / 0 / 1 digit / step]

4638	[SSCG Corection Value (Dig.)] DFU (D158/D159)		
	-		

001	Latest: RE	ENG	[-255 to 255 / 0 / 1 digit / step]
002	Latest: RO	ENG	[-255 to 255 / 0 / 1 digit / step]
003	Latest: GE	ENG	[-255 to 255 / 0 / 1 digit / step]
004	Latest: GO	ENG	[-255 to 255 / 0 / 1 digit / step]
005	Latest: BE	ENG	[-255 to 255 / 0 / 1 digit / step]
006	Latest: BO	ENG	[-255 to 255 / 0 / 1 digit / step]

4639	[SSCG Corection Value (Ana.)] DFU (D158/D159)		
	-		
001	Factory Setting: RE	*ENG	[-31 to 31 / 0 / 1 digit / step]
002	Factory Setting: RO	*ENG	[-31 to 31 / 0 / 1 digit / step]
003	Factory Setting: GE	*ENG	[-31 to 31 / 0 / 1 digit / step]
004	Factory Setting: GO	*ENG	[-31 to 31 / 0 / 1 digit / step]
005	Factory Setting: BE	*ENG	[-31 to 31 / 0 / 1 digit / step]
006	Factory Setting: BO	*ENG	[-31 to 31 / 0 / 1 digit / step]

4640	[SSCG Corection Value (Dig.)] DFU (D158/D159)		
	-		
001	Factory Setting: RE	*ENG	[-255 to 255 / 0 / 1 digit / step]
002	Factory Setting: RO	*ENG	[-255 to 255 / 0 / 1 digit / step]
003	Factory Setting: GE	*ENG	[-255 to 255 / 0 / 1 digit / step]
004	Factory Setting: GO	*ENG	[-255 to 255 / 0 / 1 digit / step]
005	Factory Setting: BE	*ENG	[-255 to 255 / 0 / 1 digit / step]
006	Factory Setting: BO	*ENG	[-255 to 255 / 0 / 1 digit / step]

4641	[SSCG Noise Amplitude] (D158/D159)		
	-		

001	RE	ENG	[0 to 1023 / 0 / 1 digit / step]
002	RO	ENG	[0 to 1023 / 0 / 1 digit / step]
003	GE	ENG	[0 to 1023 / 0 / 1 digit / step]
004	GO	ENG	[0 to 1023 / 0 / 1 digit / step]
005	BE	ENG	[0 to 1023 / 0 / 1 digit / step]
006	BO	ENG	[0 to 1023 / 0 / 1 digit / step]

4645	[White Level Adj Loop] (D160/D161/D170)		
	-		
001	Red	ENG	[0 to 30 / 0 / 1 / step]
002	Green	ENG	[0 to 30 / 0 / 1 / step]
003	Blue	ENG	[0 to 30 / 0 / 1 / step]
005	Black Level	ENG	[0 to 20 / 0 / 1 / step]

4646	[Scan Adjust Error] (D158/D159)		
	[Scan Adj Error] (D160/D161/D170)		
Displays the error value of the scanning adjustment.			
001	White level	ENG	D158/D159 [0 to 65535 / 0 / 1 / step] D160/D161/D170 [0 to 127 / 0 / 1 / step]
002	Black level	ENG	D158/D159 [0 to 65535 / 0 / 1 / step] D160/D161/D170 [0 to 3 / 0 / 1 / step]
003	SSCG Correction (D158/D159)	ENG	D158/D159 [0 to 65535 / 0 / 1 / step]

4647	[Scanner Hard Error]		
	Displays the result of the SBU connection check.		
001	Power-ON	ENG	D158/D159 [0 to 65535 / 0 / 1 / step] D160/D161/D170 [0 to 3 / 0 / 1 / step]

4651	[Black Level Adj. Value (Ana.)] (D158/D159)		
	-		
001	Latest: RE	ENG	[0 to 127 / 0 / 1 digit / step]
002	Latest: RO	ENG	[0 to 127 / 0 / 1 digit / step]

4652	[Black Level Adj. Value (Ana.)] (D158/D159)		
	-		
001	Latest: GE	ENG	[0 to 127 / 0 / 1 digit / step]
002	Latest: GO	ENG	[0 to 127 / 0 / 1 digit / step]

4653	[Black Level Adj. Value (Ana.)] (D158/D159)		
	-		
001	Latest: BE	ENG	[0 to 127 / 0 / 1 digit / step]
002	Latest: BO	ENG	[0 to 127 / 0 / 1 digit / step]

4654	[Black Level Adj. Value (Dig.)] (D158/D159)		
	Displays the last correct adjustment value of the black level. RE: Red Even signal, RO: Red Odd signal		
001	Latest: RE	ENG	Displays the black offset value for the even red signal in the CCD circuit board (color printing speed). [0 to 16383 / 0 / 1 digit / step]

002	Latest: RO	ENG	Displays the black offset value for the odd red signal in the CCD circuit board (color printing speed). [0 to 16383 / 0 / 1 digit / step]
-----	------------	-----	--

4655	[Black Level Adj. Value (Dig.)] (D158/D159)		
	Displays the last correct adjustment value of the black level. GE: Green Even signal, GO: Green Odd signal BkE: Black Even signal, BkO: Black Odd signal		
001	Latest: GE	ENG	Displays the black offset value for the even green signal in the CCD circuit board (color printing speed). [0 to 16383 / 0 / 1 digit / step]
002	Latest: GO	ENG	Displays the black offset value for the odd green signal in the CCD circuit board (color printing speed). [0 to 16383 / 0 / 1 digit / step]

4656	[Black Level Adj. Value (Dig.)] (D158/D159)		
	Displays the last correct adjustment value of the black level. BE: Blue Even signal, BO: Blue Odd signal		
001	Latest: BE	ENG	Displays the black offset value for the even blue signal in the CCD circuit board (color printing speed). [0 to 16383 / 0 / 1 digit / step]
002	Latest: BO	ENG	Displays the black offset value for the odd blue signal in the CCD circuit board (color printing speed). [0 to 16383 / 0 / 1 digit / step]

4658	[Analog Gain Adjust] (D158/D159)		
	-		
001	Latest: R	*ENG	[0 to 14 / 0 / 1 digit / step]

4659	[Analog Gain Adjust] (D158/D159)		
	-		
001	Latest: G	*ENG	[0 to 14 / 0 / 1 digit / step]

4660	[Analog Gain Adjust] (D158/D159)		
	-		
001	Latest: B	*ENG	[0 to 14 / 0 / 1 digit / step]

4661	[Digital Gain Adjust] (D158/D159)		
	Displays the last correct adjustment value of the digital gain. RE: Red Even signal, RO: Red Odd signal		
001	Latest: RE	*ENG	[0 to 1023 / 0 / 1 digit / step]
002	Latest: RO	*ENG	

4662	[Digital Gain Adjust] (D158/D159)		
	Displays the last correct adjustment value of the digital gain. GE: Green Even signal, GO: Green Odd signal		
001	Latest: GE	*ENG	[0 to 1023 / 0 / 1 digit / step]
002	Latest: GO	*ENG	[0 to 1023 / 0 / 1 digit / step]

4663	[Digital Gain Adjust] (D158/D159)		
	Displays the last correct adjustment value of the digital gain. BE: Blue Even signal, BO: Blue Odd signal		
001	Latest: BE	*ENG	[0 to 1023 / 0 / 1 digit / step]
002	Latest: BO	*ENG	

4670	[Black Level Adj. Value (Ana.)] (D158/D159)		
	-		
001	Factory Setting: RE	*ENG	[0 to 127 / 0 / 1 digit / step]

002	Factory Setting: RO	*ENG	[0 to 127 / 0 / 1 digit / step]
-----	---------------------	------	---------------------------------

4671	[Black Level Adj. Value (Ana.)] (D158/D159)		
	Displays the factory setting values of the black level.		
001	Factory Setting: GE	*ENG	[0 to 127 / 0 / 1 digit / step]
002	Factory Setting: GO	*ENG	[0 to 127 / 0 / 1 digit / step]

4672	[Black Level Adj. Value (Ana.)] (D158/D159)		
	-		
001	Factory Setting: BE	*ENG	[0 to 127 / 0 / 1 digit / step]
002	Factory Setting: BO	*ENG	[0 to 127 / 0 / 1 digit / step]

4673	[Black Level Adj. Value (Dig.)] (D158/D159)		
	[Black Level Adj] (D160/D161/D170)		
Displays the factory setting values of the black level. RE: Red Even signal, RO: Red Odd signal			
001	Factory Setting: RE (Fact:RLC_DAC)	*ENG	D158/D159 [0 to 16383 / 0 / 1 digit / step] D160/D161/D170 [0 to 15 / 0 / 1 / step]
002	Factory Setting: RO (Fact:OFFSET_DAC)	*ENG	D158/D159 [0 to 16383 / 0 / 1 digit / step] D160/D161/D170 [0 to 255 / 0 / 1 / step]

4674	[Black Level Adj. Value (Dig.)] (D158/D159)		
	Displays the factory setting values of the black level. GE: Green Even signal, GO: Green Odd signal		

001	Factory Setting: GE	*ENG	Displays the factory setting values of the black level adjustment for the even green signal in the CCD circuit board (color printing speed). [0 to 16383 / 0 / 1 digit / step]
002	Factory Setting: GO	*ENG	Displays the factory setting values of the black level adjustment for the odd green signal in the CCD circuit board (color printing speed). [0 to 16383 / 0 / 1 digit / step]

4675	[Black Level Adj. Value (Dig.)] (D158/D159)		
	Displays the factory setting values of the black level. BE: Blue Even signal, BO: Blue Odd signal		
001	Factory Setting: BE	*ENG	Displays the factory setting values of the black level adjustment for the even blue signal in the CCD circuit board (color printing speed). [0 to 16383 / 0 / 1 digit / step]
002	Factory Setting: BO	*ENG	Displays the factory setting values of the black level adjustment for the odd blue signal in the CCD circuit board (color printing speed). [0 to 16383 / 0 / 1 digit / step]

4677	[Analog Gain Adjust] (D158/D159)		
	-		
001	Factory Setting: R	*ENG	[0 to 14 / 0 / 1 digit / step]

4678	[Analog Gain Adjust] (D158/D159)		
	-		
001	Factory Setting: G	*ENG	[0 to 14 / 0 / 1 digit / step]

4679	[Analog Gain Adjust] (D158/D159)		
	-		
001	Factory Setting: B	*ENG	[0 to 14 / 0 / 1 digit / step]

4680	[Analog Gain Adjust] (D158/D159)		
	-		
001	Factory Setting: RE	*ENG	[0 to 1023 / 0 / 1 digit / step]
002	Factory Setting: RO	*ENG	

4681	[Digital Gain Adjust] (D158/D159)		
	Displays the gain value of the amplifiers on the controller for Green. GE: Green Even signal, GO: Green Odd signal		
001	Factory Setting: GE	*ENG	[0 to 1023 / 0 / 1 digit / step]
002	Factory Setting: GO	*ENG	[0 to 1023 / 0 / 1 digit / step]

4682	[Digital Gain Adjust] (D158/D159)		
	-		
001	Factory Setting: BE	*ENG	[0 to 1023 / 0 / 1 digit / step]
002	Factory Setting: BO	*ENG	

4688	[DF Density Adjustment] (D158/D159)		
	[Scan Image Density] (D160/D161/D170)		
Adjust the density difference in the ADF and the Book.			
001	(ARDF)	*ENG	D158/D159 [80 to 120 / 106 / 1 % / step] D160/D161/D170 [80 to 120 / 103 / 1 % / step]

4690	[White Level Peak Read] (D158/D159)		
	[White Level Peak] (D160/D161/D170)		
Displays the peak level of the white level scanning.			

001	RE (Red)	ENG	D158/D159 [0 to 1023 / 0 / 1 digit / step] D160/D161/D170 [0 to 255 / 0 / 1 / step]
002	RO (D158/D159)	ENG	[0 to 1023 / 0 / 1 digit / step]

4691	[White Level Peak Read] (D158/D159) [White Level Peak] (D160/D161/D170)		
	Displays the peak level of the white level scanning. GE: Green Even signal, GO: Green Odd signal		
001	GE (Green)	ENG	D158/D159 [0 to 1023 / 0 / 1 digit / step] 160/D161/D170 [0 to 255 / 0 / 1 / step]
002	GO (D158/D159)	ENG	[0 to 1023 / 0 / 1 digit / step]

4692	[White Level Peak Read] (D158/D159) [White Level Peak] (D160/D161/D170)		
	Displays the peak level of the white level scanning. BE: Blue Even signal, BO: Blue Odd signal		
001	BE (Blue)	ENG	D158/D159 [0 to 1023 / 0 / 1 digit / step] D160/D161/D170 [0 to 255 / 0 / 1 / step]
002	BO (D158/D159)	ENG	[0 to 1023 / 0 / 1 digit / step]

4693	[Black Level Peak Read] (D158/D159)		
	Displays the peak level of the black level scanning. RE: Red Even signal, RO: Red Odd signal		

001	RE	ENG	[0 to 1023 / 0 / 1 digit / step]
002	RO	ENG	

4693	[Black Level Bottom] (D160/D161/D170)		
	-		
001	Black Level	ENG	[0 to 1023 / 0 / 1 / step]

4694	[Black Level Peak Read] (D158/D159)		
	Displays the peak level of the black level scanning. GE: Green Even signal, GO: Green Odd signal		
001	GE	ENG	[0 to 1023 / 0 / 1 digit / step]
002	GO	ENG	

4695	[Black Level Peak Read] (D158/D159)		
	Displays the peak level of the black level scanning. BE: Blue Even signal, BO: Blue Odd signal		
001	BE	ENG	[0 to 1023 / 0 / 1 digit / step]
002	BO	ENG	

4698	[Factory Setting Input] (D158/D159)		
	-		
001	ON/OFF	ENG	[0 or 1 / 0 / 1 / step]
002	Execution Flag	*ENG	

4699	[SBU Test Pattern Change] (D158/D159)		
	-		
001	-	ENG	[0 to 255 / 0 / 1 / step]

4802	[Scanner Free run DF mode] (D158/D159)		
	Executes the document feeder shading free run.		
001	Lamp Off	ENG	Turns off the scanner lamp. [0 or 1 / 0 / 1 / step]
002	Lamp On		Turns on the scanner lamp. [0 or 1 / 0 / 1 / step]

4803	[Home Position Adj Value] (D158/D159)		
	[Home Position Adj] (D160/D161/D170)		
	-		
001	-	*ENG	Adjusts the scanner home position. [-2.0 to 2.0 / 0.0 / 0.1 mm / step]

4804	[Home Position Operation] (D158/D159)		
	-		
001	Home Position Operation	ENG	Executes the scanner HP detection. [0 or 1 / 0 / 0 / step]

4806	[Scan Carriage Retract Op] (D158/D159)		
	-		
001	-	ENG	Moves the carriage from the scanner home position. Dust may fall through the DF exposure glass. Therefore, do this SP when you transport the machine a long distance. [0 or 1 / 0 / 0 / step]

4807	[SBU Off Mode] (D158/D159)		
	-		
001	On/Off	*ENG	[0 or 1 / 1 / 0 / step]

4813	[ALC Selection] (D158/D159)		
	-		
001	FC	*ENG	[0 or 1 / 1 / 1 / step]
002	BW	*ENG	[0 or 1 / 1 / 1 / step]

4850	[PMW] (D158/D159)		
	-		
001	Latest	*ENG	[0 to 8191 / 0 / 1 digit / step]
002	Factory Setting	*ENG	[0 to 8191 / 0 / 1 digit / step]

4850	[LED Lighting Duty:C] (D160/D161/D170)		
	-		
001	Latest:Red	ENG	[0 to 16383 / 0 / 1 / step]
003	Latest:Green	ENG	[0 to 16383 / 0 / 1 / step]
005	Latest:Blue	ENG	[0 to 16383 / 0 / 1 / step]

4851	[LED White Level Peak Read] (D158/D159)		
	[LED Lighting Duty:C] (D160/D161/D170)		
	-		
001	Latest: RE (Last:Red)	*ENG	D158/D159 [0 to 1023 / 0 / 1 digit / step] D160/D161/D170 [0 to 16383 / 1360 / 1 / step]
002	Latest: RO (D158/D159)	*ENG	[0 to 1023 / 0 / 1 digit / step]
003	Latest: GE (Last:Green)	*ENG	D158/D159 [0 to 1023 / 0 / 1 digit / step] D160/D161/D170 [0 to 16383 / 1360 / 1 / step]

004	Latest: GO (D158/D159)	*ENG	[0 to 1023 / 0 / 1 digit / step]
005	Latest: BE (D158/D159)	*ENG	[0 to 1023 / 0 / 1 digit / step]
006	Latest: BO (Last:Blue)	*ENG	D158/D159 [0 to 1023 / 0 / 1 digit / step] D160/D161/D170 [0 to 16383 / 1360 / 1 / step]

4852	[LED White Level Peak Read] (D158/D159)		
	[LED Lighting Duty:C] (D160/D161/D170)		
	-		
001	Factory Setting: BO (Fact:Red)	*ENG	D158/D159 [0 to 1023 / 0 / 1 digit / step] D160/D161/D170 [0 to 16383 / 1 / 1 / step]
002	Factory Setting: RO (D158/D159)	*ENG	[0 to 1023 / 0 / 1 digit / step]
003	Factory Setting: GE (Fact:Green)	*ENG	D158/D159: [0 to 1023 / 0 / 1 digit / step] D160/D161/D170 [0 to 16383 / 0 / 1 / step]
004	Factory Setting: GO (D158/D159)	*ENG	[0 to 1023 / 0 / 1 digit / step]
005	Factory Setting: GO (Fact:Blue)	*ENG	D158/D159 [0 to 1023 / 0 / 1 digit / step] D160/D161/D170 [0 to 16383 / 0 / 1 / step]
006	Factory Setting: BO (D158/D159)	*ENG	[0 to 1023 / 0 / 1 digit / step]

4903	[Filter Setting] (D158/D159)		
	This SP outputs the final data read at the end of ACC execution. A zero is returned if there was an error reading the data.		
001	Ind Dot Erase: Text	*ENG	Photo C Patch Level 1 (8-bit) [0 to 7 / 0 / 1 / step]
002	Ind Dot Erase: Generation Copy	*ENG	Photo M Patch Level 1 (8-bit) [0 to 7 / 0 / 1 / step]

4903	[ADS Level] (D160/D161/D170)		
	Adjusts the ADS level.		
001	ADS Level	*ENG	[0 to 255 / 252 / 1 / step]

4904	[ADS Lower Limit] (D160/D161/D170)		
	Adjusts the ADS lower limit.		
001	ADS Lower Limit	*ENG	[0 to 255 / 80 / 1 / step]

4905	[Select Gradation Level] (D158/D159)		
	-		
001	Select Gradation Level	*ENG	[0 to 255 / 0 / 1 / step]

4905	[ADS Area Select] (D160/D161/D170)		
	Checks the whole area (0 = All) or the specific areas (1 = One) to adjust the ADS level. The specific areas are as follows: ADF: 15 to 90 mm from the left edge Platen Cover: 15 to 90 mm from the left edge		
001	Select Gradation Level	*ENG	[0 or 1 / 0 / 1 / step]

4918	[Man Gamma Adj] (DFU) (D158/D159)		
	Adjusts the manual gamma for Copy/Photo or Copy/Text with the soft keys on the operation panel.		

009	Man Gamma Adj	ENG	[- / - / -]
4921	[Image Adj Select] (D160/D161/D170)		
001	Copy	*ENG	[0 to 10 / 0 / 1 / step]
	<p>Selects which mode the settings from SP4-922 to SP4-932 are used for.</p> <p>0 = None, 1 = Text 1, 2 =Text 2, 3= Photo 1, 4 = Photo 2, 5 = Photo 3, 6 = Special 1, 7 = Special 2, 8 = Special 3, 9 = Special 4, 10 = Special 5</p>		
4922	[Scanner Gamma] (D160/D161/D170)		
001	Copy	*ENG	[0 to 2 / 0 / 1 / step]
	<p>Selects "text" or "photo" as the priority output mode. This setting is applied to all image processing modes of SP4-921.</p> <p>[0=System default / 1=Text / 2=Photo]</p>		
4923	[Notch Selection] (D160/D161/D170)		
001	Copy	*ENG	[-1 to 1 / 0 / 1 / step]
	<p>Selects the value of the center ID adjustment notch for the ID adjustment LEDs.</p> <ul style="list-style-type: none"> • Normally the center notch is 3 (range 1-5). If -1 is selected, each notch shifts down (becomes lighter). If +1 is selected, each notch shifts up (becomes darker). • This setting is applied to all image processing modes of SP4-921. 		
4926	[Texture Removal] (D160/D161/D170)		

	Copy	*ENG	[0 to 6 / 0 / 1 / step]
001	<p>Adjusts the texture removal level that is used with error diffusion. 0: The default value for each mode is used. Text 1, Photo 2, Special 2, and Special 5 have a default of 3 and Photo 1, 3 have a default of 6.</p> <p>1: No removal applied.</p> <p>2 – 6: Removal applied at the level specified here.</p> <p>The higher the setting (level), the less clear the image will become (more texture removal). This setting is only applied to the originals in SP4-921.</p>		

4927	[Line Width] (D160/D161/D170)		
	Copy	*ENG	[-2 to 2 / 0 / 1 / step]
001	<p>Adjusts the line width correction algorithm. Positive settings produce thicker lines; negative settings produce thinner lines. This setting is only applied to the originals in SP4-921.</p>		

4928	[IndpndntDot Erase] (D160/D161/D170)		
	Copy	*ENG	[-2 to 2 / 0 / 1 / step]
001	<p>Selects the dot erase level. Higher settings provide greater erasure. This setting is only applied to the originals in SP4-921.</p>		

4929	[Positive/Negative] (D160/D161/D170)		
	Copy	*ENG	[0 or 1 / 0 / 1 / step]
001	<p>Inverts white and black. This setting is only applied to the originals in SP4-921.</p>		

4930	[Sharpness-Edge] (D160/D161/D170)		
	Copy	*ENG	[-2 to 2 / 0 / 1 / step]
001	<p>Adjust the clarity. This setting is only applied to the originals in SP4-921.</p>		

4931	[Sharpness-Solid] (D160/D161/D170)		
-------------	---	--	--

001	Copy	*ENG	[-2 to 2 / 0 / 1 / step]
	Adjust the clarity. This setting is only applied to the originals in SP4-921.		
4932	[Sharpness-LowID] (D160/D161/D170)		
001	Copy	*ENG	[-2 to 2 / 0 / 1 / step]
	Adjust the clarity. This setting is only applied to the originals in SP4-921.		
4941	[White Line Erase] (D160/D161/D170)		
001	White Line Erase	*ENG	[0 to 2 / 0 / 1 / step]
	Selects the white line erase level. 0: None 1: Weak 2: Strong <ul style="list-style-type: none"> • This setting is effective for all modes. • 0: White line erase is not used, and white level correction is used instead. • This setting is applied regardless of what mode has been selected in SP4-921. 		
4942	[Black Line Erase] (D160/D161/D170)		
001	Black Line Erase	*ENG	[0 to 3 / 2 / 1 / step]
	Selects the black line erase level. This setting is effective only when originals are scanned by the DF. [0 = No / 1 = Very weak / 2 = Weak / 3 = Strong] This setting is applied regardless of what mode has been selected in SP4-921.		
4954	[Read/Restore:Std] (D158/D159)		
Reads or restores the standard chart.			
005	Chroma Rank	*ENG	Restores the standard chromaticity rank. [0 to 255 / 0 / 1 / step]
4991	[IPU Image Pass Selection] (D158/D159)		
-			

001	RGB Frame Memory	ENG	[0 to 19 / 2 / 1 / step]
002	Filter test output	ENG	[0 to 28 / 24 / 1 / step]
003	Filter FM output	ENG	[0 to 15 / 1 / 1 / step]
004	Filter CPR output	ENG	[0 to 15 / 0 / 1 / step]

4993	[High Light Correction] (D158/D159)		
	-		
001	Sensitivity Selection	*ENG	Selects the Highlight correction level. [0 to 9 / 4 / 1 / step] 0: weakest sensitivity 9: strongest sensitivity
002	Range Selection	*ENG	Selects the range level of Highlight correction. [0 to 9 / 4 / 1 / step] 0: weakest skew correction, 9: strongest skew correction

4994	[Adj Txt/Photo Recog Level] (D158/D159)		
	Selects the definition level between Text and Photo for high compression PDF.		
001	High Compression PDF	*ENG	[0 to 2 / 1 / 1 / step]

4996	[White Paper Detection Level] (D158/D159)		
	-		
001	-	*ENG	[0 to 6 / 3 / 1 / step]

Main SP Tables-5

SP5-XXX (Mode)

5001	[All Indicators On] (D160/D161/D170)		
	All LEDs turn on. The LCD turns on or off every 3 seconds. Press the reset key to end this program.		
001	-	CTL	-

3

5009	[Add Disp. Lang] (D158/159)		
	Adds language available in user choice. (Only the languages registered in the machine) Refer to the displayed language list to set in the way showed below. List Num.Assigned Bit Switch No.1~8BIT1 to 8 (SP5009-201) No.9~16BIT1 to 8 (SP5009-202) No.17~24BIT1 to 8 (SP5009-203) No.25~32BIT1 to 8 (SP5009-204) Example: To add American(No.3 in the list) or Czech (No.15) Turn Bit 3 of "SP5009-201" 0 to 1 for American. Turn Bit 7 of "SP5009-202" 0 to 1 for Czech . After setting, turn the main power switch off and on to make the setting valid.		
	201	Bit SW	* CTL
	202	Bit SW	* CTL
	203	Bit SW	* CTL
204	Bit SW	* CTL	[1 to 255/ 0 / 1 / step]

5024	[mm/inch Display Selection] (D158/159)		
	Selects the unit of measurement. After selection, turn the main power switch off and on.		

001	0:mm 1:inch	*CTL	[0 or 1 / 0 / 1 / step] 0: mm (Europe/Asia) 1: inch (North America)
5045	[Accounting Counter] (D158/159) [Dsply-Counter] (D160/D161/D170)		
	Selects the counting method to either developments or prints. Note <ul style="list-style-type: none"> The counting method can be changed only once, regardless of whether the counter value is negative or positive. 		
001	Counter Method	*CTL	[0 or 1 / 0 / 1 / step] 0: Developments 1: Prints
5047	[Paper Display] (D158/159)		
001	-	*CTL	[0 or 1 / - / 1 / step] 0: OFF, 1:ON
5055	[Display IP Address] (D158/159)		
	Display or does not display the IP address on the operation panel.		
001	Display IP Address	*CTL	[0 or 1 / 0 / 1/step] 0: OFF, 1: ON
5062	[Parts PM Display Setting] (D158/159)		
	Display or does not display the PM part yield on the LCD.		
001	-	*CTL	[0 or 1 / 0 / 1/step] 0: No display, 1: Display
5066	[PM Parts Display] (D158/159) Display or does not display the "PM parts" button on the LCD.		

001	PM Parts Display	*CTL	[0 or 1 / 0 / 1/step] 0: No display, 1: Display
-----	------------------	------	--

5067	[Parts PM System Setting] (D158/159)		
	Selects the service maintenance or user maintenance for each PM parts. If the user service is selected, PM alert is displayed on the LCD.		
001	-	*CTL	[0 or 1 / 0 / 1/step] 0: Service, 1: User

5071	[Set Bypass Paper Size Display] (D158/159)		
001	Set Bypass Paper Size Display	CTL	[0 or 1 / 0 / 1/step] 0: Disable, 1: Enable
	Enables or disables the bypass paper size display for confirmation		

5074	[HomeScreenLogin] (D158/159)		
002	Home Screen Login Setting	*CTL	[FFh / 0x0 / 1hex/step] 0:On, 1:Off
091	(0:OFF 1:SDK 2:Reserve)	*CTL	[0 to 2 / 0 / 1/step] 0: Function disable 1: SDK application 2: Legacy application (reserved)
092	Product ID	*CTL	Sets the Application product ID. [0x00 to 0xFFFF FFFF / 0 / 1/step]
093	Application ID	*CTL	Sets the display category of the application that is specified in the SP5075-001,002 [0 to 255 / 0 / 1/step]

5075	[USB Keyboard] (D158/159)		
------	----------------------------------	--	--

001	Function Setting	*CTL	[0 or 1 / 0 / 1/step] 0: Disable 1: Enable
5083	[TonerNearEndLedSetting] (D158/159)		
	Turns LED lighting ON and OFF at Toner Near End.		
001	0: OFF 1: ON	*CTL	[0 or 1 / 1 / 1/step] 0: OFF, 1: ON
5104	[DoubleCount] (D158/159) [A3 Double Count] (D160/D161/D170)		
	Specifies whether the counter is doubled for A3/DLT. "Yes" counts except from the bypass tray. When "Yes" is selected, A3 and DLT paper are counted twice, that is A4 x2 and LT x2 respectively.		
001	0: OFF 1: ON	*CTL	[0 or 1 / 1 / 1/step] 0: OFF, 1: ON
002	ManSizeNoFixExchangeOverA3 (D158/159)	*CTL	[0 or 1 / 0 / 1/step] 0: A4 (LT), 1: A3 (DLT)
5112	[Non-Std. Paper Sel.] (D158/159)		
	Selects On/Off to allow the setting of the custom size.		
001	(0:OFF 1:ON)	*CTL	[0 or 1 / 1 / 1/step] 0: OFF, 1: ON
5113	[Optional Counter Type] (D158/159) [Op Counter Type] (D160/D161/D170)		

001	Default Optional Counter Type (D158/159)	*CTL	This program specifies the counter type. [0 to 9 / 0 / 1/step] 0: None, 1: Key card (RK 3, 4) 2: Key card (down), 3: Prepaid card 4: Coin lock, 5: MF key card 8: Key counter + Vendor 9: Bar-code Printer
001	Op Counter Type (D160/D161/D170)	*CTL	[0 to 12 / 0 / 1/step] 0: None 11: MF key card (Increment) 12: MF key card (Decrement)
002	External Optional Counter Type (D158/159)	*CTL	This program specifies the external counter type. [0 to 3 / 0 / 1/step] 0: None 1: Expansion Device 1 2: Expansion Device 2 3: Expansion Device 3

5114	[Optional Counter I/F] (D158/159)		
	Set when connecting an expansion unit using the MF key card I/F. Use this SP and change the setting to "1" only when the "5" (MF Key Card) is selected with SP5113-001.		
001	MF Key Card Extension	*CTL	[0x00 or 0x01 / 0x00 / 1/step] 0: Not installed 1: Installed (scanning accounting)

5118	[Disable Copying] (D158/159)		
	This program disables copying.		
001	Disable Copying	*CTL	[0 or 1 / 0 / 1/step] 0: Not disabled 1: Disabled

5120	<p>[Mode Clear Opt. Counter Removal] (D158/159) [Clr-OP Count Remv] (D160/D161/D170)</p>		
	<p>This program updates the information on the optional counter. When you install or remove an optional counter, check the settings.</p>		
001	0:Yes 1:StandBy 2:No	*CTL	<p>[0 to 2 / 0 / 1/step] 0: Yes. (Always mode clear) 1: StandBy. (Mode clear before/after a job) 2: No. (No mode clear)</p>
5121	<p>[Counter Up Timing]</p>		
	<p>This program specifies when the counter goes up. The settings refer to "paper feed" and "paper exit" respectively.</p>		
001	0:Feed 1:Exit	*CTL	<p>[0 or 1 / 0 / 1/step] 0: Feed, 1: Exit</p>
5126	<p>[Set F-size Document] (D158/159) [F-size Document] (D160/D161/D170)</p>		
	<p>Selects F size original setting.</p>		
001	-	ENG	<p>[0 to 2 / 0 / 1/step] 0: 8 1/2 x 13 (Foolscap) 1: 8 1/4 x 13 (Folio) 2: 8 x 13 (F)</p>
5127	<p>[APS Mode]</p>		
	<p>Selects whether the APS function is enabled or disabled with the contact of a pre-paid card or coin lock.</p>		
001	APS Mode	*CTL	<p>[0 or 1 / 0 / 1/step] 0: Enabled 1: Disabled</p>

5131	[Paper Size Type Selection] (D158/159)		
	The program selects a paper size system from the following alternatives: the AB system (0), the LT system (1), and the AF system (2).		
001	Paper Size Type Selection	*ENG	[1 to 2 / 1(NA), 2(EU, ASIA, CHN, TW) / 1/step]
5150	[Bypass Length Setting] (D158/159)		
	Sets up the by-pass tray for long paper.		
001	0: OFF 1: ON	CTL	[0 or 1 / 0 / 1/step] 0: OFF, 1: ON
5162	[App. Switch Method] (D158/159)		
	Determines whether the application screen is switched with a hardware switch or software switch.		
001	App. Switch Method	*CTL	[0 or 1 / 0 / 1/step] 0: Soft Key Set 1: Hard Key Set
5166	[Auto Delete Time] (D158/159)		
	Last Deleted Time		
021	Auto Delete Time	*CTL	[0 to 4294967295 / 0 / 1/step]
5167	[Fax Printing Mode at Optional Counter Off] (D158/159)		
	Enables or disables the automatic print out without an accounting device. This SP is used when the receiving fax is accounted by an external accounting device.		
001	FaxPrnt CntOff	*CTL	[0 or 1 / 0 / 1/step] 0: Automatic printing 1: No automatic printing

5169	[CE Login] (D158/159)		
	If you will change the printer bit switches, you must 'log in' to service mode with this SP before you go into the printer SP mode.		
001	CE Login	*CTL	[0 or 1 / 0 / 1/step] 0: Disabled 1: Enabled

5181	[Tray Size Adjust] (D158/159)		
	Adjusts the paper size for each tray.		
001	Tray1:1	*ENG	[0 or 1 / 1(NA), 0(EU, ASIA, CHN,TW) / 1/step] 0: A4 LEF 1: LE LEF
002	Tray1:2	*ENG	[0 or 1 / 1(NA), 0(EU, ASIA, CHN,TW) / 1/step] 0: A3 1: DLT
003	Tray1:3	*ENG	[0 or 1 / 1(NA), 0(EU, ASIA, CHN,TW) / 1/step] 0: B4 1: LG
004	Tray1:4	*ENG	[0 or 1 / 1(NA), 0(EU, ASIA, CHN,TW) / 1/step] 0: B5 LEF 1: Exe LEF
006	Tray2:1	*ENG	[0 or 1 / 1(NA), 0(EU, ASIA, CHN,TW) / 1/step] 0: A4 LEF 1: LE LEF

007	Tray2:2	*ENG	[0 or 1 / 1(NA), 0(EU, ASIA, CHN,TW) / 1/step] 0: A3 1: DLT
008	Tray2:3	*ENG	[0 or 1 / 1(NA), 0(EU, ASIA, CHN,TW) / 1/step] 0: B4 1: LG
009	Tray2:4	*ENG	[0 or 1 / 1(NA), 0(EU, ASIA, CHN,TW) / 1/step] 0: B5 LEF 1: Exe LEF
010	Tray3:1	*ENG	[0 or 1 / 1(NA), 0(EU, ASIA, CHN,TW) / 1/step] 0: A4 LEF 1: LE LEF
011	Tray3:2	*ENG	[0 or 1 / 1(NA), 0(EU, ASIA, CHN,TW) / 1/step] 0: A3 1: DLT
012	Tray3:3	*ENG	[0 or 1 / 1(NA), 0(EU, ASIA, CHN,TW) / 1/step] 0: B4 1: LG
013	Tray3:4	*ENG	[0 or 1 / 1(NA), 0(EU, ASIA, CHN,TW) / 1/step] 0: B5 LEF 1: Exe LEF
014	Tray4:1	*ENG	[0 or 1 / 1(NA), 0(EU, ASIA, CHN,TW) / 1/step] 0: A4 LEF 1: LE LEF

015	Tray4:2	*ENG	[0 or 1 / 1(NA), 0(EU, ASIA, CHN,TW) / 1/step] 0: A3 1: DLT
016	Tray4:3	*ENG	[0 or 1 / 1(NA), 0(EU, ASIA, CHN,TW) / 1/step] 0: B4 1: LG
017	Tray4:4	*ENG	[0 or 1 / 1(NA), 0(EU, ASIA, CHN,TW) / 1/step] 0: B5 LEF 1: Exe LEF
018	Tray1:5	*ENG	[0 or 1 / 1(NA), 0(EU, ASIA, CHN,TW) / 1/step] 0: A5 LEF 1: HLT LEF
019	Tray2:5	*ENG	[0 or 1 / D158: 0(NA,EU, ASIA, CHN,TW), D159:1(NA), 0(EU, ASIA, CHN,TW) / 1/step] 0: A5 LEF 1: HLT LEF

5181	[Tray Size Adjust] (D160/D161/D170)		
	Adjusts the paper size for each tray.		
001	Tray1:1(EU)	*ENG	[0 or 1 / 0 / 1/step] 0: A4 LEF 1: LE LEF
002	Tray1:2(EU)	*ENG	[0 or 1 / 0 / 1/step] 0: A3 1: DLT

003	Tray1:3(EU)	*ENG	[0 or 1 / 0 / 1/step] 0: B4 1: LG
004	Tray1:4(EU)	*ENG	[0 or 1 / 0 / 1/step] 0: B5 LEF 1: Exe LEF
006	Tray2:1(EU)	*ENG	[0 or 1 / 0 / 1/step] 0: A4 LEF 1: LE LEF
007	Tray2:2(EU)	*ENG	[0 or 1 / 0 / 1/step] 0: A3 1: DLT
008	Tray2:3(EU)	*ENG	[0 or 1 / 0 / 1/step] 0: B4 1: LG
009	Tray2:4(EU)	*ENG	[0 or 1 / 0 / 1/step] 0: B5 LEF 1: Exe LEF
010	Tray3:1(EU)	*ENG	[0 or 1 / 0 / 1/step] 0: A4 LEF 1: LE LEF
011	Tray3:2(EU)	*ENG	[0 or 1 / 0 / 1/step] 0: A3 1: DLT
012	Tray3:3(EU)	*ENG	[0 or 1 / 0 / 1/step] 0: B4 1: LG
013	Tray3:4(EU)	*ENG	[0 or 1 / 0 / 1/step] 0: B5 LEF 1: Exe LEF

014	Tray4:1(EU)	*ENG	[0 or 1 / 0 / 1/step] 0: A4 LEF 1: LE LEF
015	Tray4:2(EU)	*ENG	[0 or 1 / 0 / 1/step] 0: A3 1: DLT
016	Tray4:3(EU)	*ENG	[0 or 1 / 0 / 1/step] 0: B4 1: LG
017	Tray4:4(EU)	*ENG	[0 or 1 / 0 / 1/step] 0: B5 LEF 1: Exe LEF
018	Tray1:5(EU)	*ENG	[0 or 1 / 0 / 1/step] 0: A5 LEF 1: HLT LEF
019	Tray2:5(EU)	*ENG	[0 or 1 / 0 / 1/step] 0: A5 LEF 1: HLT LEF
021	Tray1:1(NA)	*ENG	[0 or 1 / 1 / 1/step] 0: A4 LEF 1: LE LEF
022	Tray1:2(NA)	*ENG	[0 or 1 / 1 / 1/step] 0: A3 1: DLT
023	Tray1:3(NA)	*ENG	[0 or 1 / 1 / 1/step] 0: B4 1: LG
024	Tray1:4(NA)	*ENG	[0 or 1 / 1 / 1/step] 0: B5 LEF 1: Exe LEF

026	Tray2:1(NA)	*ENG	[0 or 1 / 1 / 1/step] 0: A4 LEF 1: LE LEF
027	Tray2:2(NA)	*ENG	[0 or 1 / 1 / 1/step] 0: A3 1: DLT
028	Tray2:3(NA)	*ENG	[0 or 1 / 1 / 1/step] 0: B4 1: LG
029	Tray2:4(NA)	*ENG	[0 or 1 / 1 / 1/step] 0: B5 LEF 1: Exe LEF
030	Tray3:1(NA)	*ENG	[0 or 1 / 1 / 1/step] 0: A4 LEF 1: LE LEF
031	Tray3:2(NA)	*ENG	[0 or 1 / 1 / 1/step] 0: A3 1: DLT
032	Tray3:3(NA)	*ENG	[0 or 1 / 1 / 1/step] 0: B4 1: LG
033	Tray3:4(NA)	*ENG	[0 or 1 / 1 / 1/step] 0: B5 LEF 1: Exe LEF
034	Tray4:1(NA)	*ENG	[0 or 1 / 1 / 1/step] 0: A4 LEF 1: LE LEF
035	Tray4:2(NA)	*ENG	[0 or 1 / 1 / 1/step] 0: A3 1: DLT

036	Tray4:3(NA)	*ENG	[0 or 1 / 1 / 1/step] 0: B4 1: LG
037	Tray4:4(NA)	*ENG	[0 or 1 / 1 / 1/step] 0: B5 LEF 1: Exe LEF
038	Tray1:5(NA)	*ENG	[0 or 1 / 1 / 1/step] 0: A5 LEF 1: HLT LEF
039	Tray2:5(NA)	*ENG	[0 or 1 / 1 / 1/step] 0: A5 LEF 1: HLT LEF

5186	[RK4: Setting] (D158/159)		
	Enables or disables the prevention for RK4 (accounting device) disconnection. If the RK4 is disconnected for 10 seconds when this SP is set to "1 (Enable)", the machine automatically jams a sheet of paper.		
001	-	*ENG	[0 or 1 / 0 / 1/step] 0: Disable 1: Enable

5188	[Copy NvVersion] (D158/159)		
	Displays the version number of the NVRAM on the controller board.		
001	Copy MvVersion	*CTL	[- / - / -]

5191	[Power Setting] (D158/159)		
	Shifts to the power save mode or not.		
001	Power Str	*CTL	[0 or 1 / 1 / 1/step] 0: OFF, 1: ON

5193	[External Controller Info. Settings] (D158/159)		
	External controller settings.		
001	-	CTL	[0 to 10 / 0 / 1/step] 0: External Controller is not installed 1: EFI, 2: Ratio, 3: Egret 4: GJ, 5:Creo, 6: QX-100 7: Kurofune 8~10: Reserved
5195	[SC991 Operation Mode Setting] (D158/159)		
	Sets whether or not to display the icon.		
002	SC Icon Display Setting	*CTL	[0 or 1 / 0 / 1/step]
5199	[Paper Exit After Staple End] (D158/159)		
	This SP determines whether the machine can output paper if staple supply runs out.		
001	0: OFF, 1:ON	CTL	[0 to 1 / 0 / 1] 0: OFF. Paper cannot exit if no staples are available. 1: ON. Paper can exit with no staples.
5302	[Set Time] (D158/159)		
	Adjusts the RTC (real time clock) time setting for the local time zone. Examples: For Japan (+9 GMT), enter 540 (9 hours x 60 min.) DOM: +540 (Tokyo) NA: -300 (New York) EU: + 60 (Paris) CH: +480 (Peking) TW: +480 (Taipei) AS: +480 (Hong Kong) KO: +540 (Korea)		
002	Time Difference	*CTL	[-1440 to 1440 / -300 / 1 min./step]

5307		[Summer Time] (D158/159)	
001	Usable	*CTL	[0 to 1 / - / 1/step] 0: Disabled 1: Enabled (Default) 1: NA and EUR 0: ASIA and others
	Enables or disables the summer time mode. Note <ul style="list-style-type: none"> Make sure that both SP5-307-3 and -4 are correctly set. Otherwise, this SP is not activated even if this SP is set to "1". 		
003	start data set	*CTL	[0 to 0xffffffff / - / 1hex/step] (Default) NA: 0x03200210 EUR: 0x03500010 ASIA: 0x10500010 Other: 0x00000000
	Specifies the start setting for the summer time mode. There are 8 digits in this SP. For months 1 to 9, the "0" cannot be input in the first digit, so the eight-digit setting for -2 or -3 becomes a seven-digit setting. 1st and 2nd digits: The month. [1 to 12] 3rd digit: The week of the month. [1 to 5] 4th digit: The day of the week. [0 to 6 = Sunday to Saturday] 5th and 6th digits: The hour. [00 to 23] 7th digit: The length of the advanced time. [0 to 9 / 1 hour /step] 8th digit: The length of the advanced time. [0 to 5 / 10 minutes /step] <ul style="list-style-type: none"> The digits are counted from the left. Make sure that SP5-307-1 is set to "1". 		
	For example: 3500010 (EU default) The timer is advanced by 1 hour at am 0:00 on the 5th Sunday in March		

	end data set	*CTL	[0 to 0xffffffff / - / 1hex/step] (Default) NA: 0x11100200 EUR: 0x10500100 ASIA: 0x03100000 Other: 0x00000000
004	<p>Specifies the end setting for the summer time mode.</p> <p>There are 8 digits in this SP.</p> <p>1st and 2nd digits: The month. [1 to 12]</p> <p>3rd digit: The week of the month. [0 to 5]</p> <p>4th digit: The day of the week. [0 to 7 = Sunday to Saturday]</p> <p>5th and 6th digits: The hour. [00 to 23]</p> <p>The 7th and 8 digits must be set to "00".</p> <ul style="list-style-type: none"> • The digits are counted from the left. • Make sure that SP5-307-1 is set to "1". 		

5401	[Access Control] (D158/159)		
103	Default Document ACL	*CTL	[0 to 3 / 0 / 1/step] 0: Read Only 1: Edit 2: Edit/Delete 3: Full control
104	Authentication Time	*CTL	[1 to 255 / 0 / 1sec/step] 0: 60 seconds 1 to 250 seconds
	Specifies the timeout of the authentication.		
162	ExtAuth Detail	*CTL	[- / 0x00 / 0x01/step]
	<p>Selects the log out type for the extend authentication device.</p> <p>Bit 0: Log-out without an IC card</p> <p>0: Not allowed (default)</p> <p>1: Allowed</p>		

200	SDK1 UniqueID	*CTL	[0 to 0xffffffff / 0 / 1/step]
201	SDK1 Certification Method	*CTL	[0 to 0xff / 0 / 1/step]
210	SDK2 UniqueID	*CTL	[0 to 0xffffffff / 0 / 1/step]
211	SDK2 Certification Method	*CTL	[0 to 0xff / 0 / 1/step]
220	SDK3 UniqueID	*CTL	[0 to 0xffffffff / 0 / 1/step]
221	SDK3 Certification Method	*CTL	[0 to 0xff / 0 / 1/step]
230	SDK Certification Device	*CTL	<p>[- / 0 / -]</p> <p>0-1: SDK authentication available</p> <p>0-0: Disable all functions</p> <p>1-1: SKB Display</p> <p>1-0: Disable</p> <p>2-1: Administrator login</p> <p>2-0: Disable</p> <p>3~7-0: Reserved (set "0" only)</p>
240	Detail Option	*CTL	<p>[/ 0x00 / 0x01/step]</p> <p>0: Logout confirm option</p> <p>-1: ON, 0: OFF</p> <p>2~1: Auto-logout timer(retry timer)</p> <p>-11: 30sec, 10: 20sec,</p> <p>01: 10sec, 00: 60sec</p> <p>3: personal authority / Group authority and operation</p> <p>-1: ON, 0: OFF</p> <p>4: Skip password entry</p> <p>-1: ON, 0: OFF</p> <p>5: Set the display of the remaining Frequence</p> <p>-1: ON, 0: OFF</p> <p>6~7: Set the display time</p> <p>-1: ON, 0: OFF</p>

5402	[Access Control] (D158/159)		
101	SDKJ1 Limit Setting	* CTL	[/ 0x00 / 0x01 /step]
102	SDKJ2 Limit Setting	* CTL	bit0: SDKJ Authentication
103	SDKJ3 Limit Setting	* CTL	-0: Panel Type
104	SDKJ4 Limit Setting	* CTL	-1: Remote Type
105	SDKJ5 Limit Setting	* CTL	bit1: Using user code setup
106	SDKJ6 Limit Setting	* CTL	-0: OFF, 1: ON
107	SDKJ7 Limit Setting	* CTL	bit2: Using key-counter setup
108	SDKJ8 Limit Setting	* CTL	-0: OFF, 1: ON
109	SDKJ9 Limit Setting	* CTL	bit3: Using external billing device setup
110	SDKJ10 Limit Setting	* CTL	-0: OFF, 1: ON bit4: Using extended external billing device setup bit5~6: Not used bit7: Using extended function J limit users -0: OFF, 1: ON
111	SDKJ11 Limit Setting	* CTL	[/ 0x00 / 0x01 /step]
112	SDKJ12 Limit Setting	* CTL	bit0: SDKJ Authentication
113	SDKJ13 Limit Setting	* CTL	-0: Panel Type
114	SDKJ14 Limit Setting	* CTL	-1: Remote Type
115	SDKJ15 Limit Setting	* CTL	bit1: Using user code setup
116	SDKJ16 Limit Setting	* CTL	-0: OFF, 1: ON
117	SDKJ17 Limit Setting	* CTL	bit2: Using key-counter setup
118	SDKJ18 Limit Setting	* CTL	-0: OFF, 1: ON
119	SDKJ19 Limit Setting	* CTL	bit3: Using external billing device setup
120	SDKJ20 Limit Setting	* CTL	-0: OFF, 1: ON bit4: Using extended external billing device setup bit5~6: Not used bit7: Using extended function J limit users -0: OFF, 1: ON

121	SDKJ21 Limit Setting	*CTL	[/ 0x00 / 0x01/step]
122	SDKJ22 Limit Setting	*CTL	bit0: SDKJ Authentication
123	SDKJ23 Limit Setting	*CTL	-0: Panel Type
124	SDKJ24 Limit Setting	*CTL	-1: Remote Type
125	SDKJ25 Limit Setting	*CTL	bit1: Using user code setup
126	SDKJ26 Limit Setting	*CTL	-0: OFF, 1: ON
127	SDKJ27 Limit Setting	*CTL	bit2: Using key-counter setup
128	SDKJ28 Limit Setting	*CTL	-0: OFF, 1: ON
129	SDKJ29 Limit Setting	*CTL	bit3: Using external billing device setup
130	SDKJ30 Limit Setting	*CTL	-0: OFF, 1: ON
			bit4: Using extended external billing device setup
			-0: OFF, 1: ON
			bit5~6: Not used
			bit7: Using extended function J limit users
			-0: OFF, 1: ON

5402	[Access Control] (D158/159)
	Sets limited uses for SDKJ application data.

141	SDKJ1 ProductID	* CTL	[0 to 0xffffffff / 0 / 1/step]
142	SDKJ2 ProductID	* CTL	
143	SDKJ3 ProductID	* CTL	
144	SDKJ4 ProductID	* CTL	
145	SDKJ5 ProductID	* CTL	
146	SDKJ6 ProductID	* CTL	
147	SDKJ7 ProductID	* CTL	
148	SDKJ8 ProductID	* CTL	
149	SDKJ9 ProductID	* CTL	
150	SDKJ10 ProductID	* CTL	
151	SDKJ11 ProductID	* CTL	
152	SDKJ12 ProductID	* CTL	
153	SDKJ13 ProductID	* CTL	
154	SDKJ14 ProductID	* CTL	

155	SDKJ15 ProductID	* CTL	[0 to 0xffffffff / 0 / 1/step]
156	SDKJ16 ProductID	* CTL	
157	SDKJ17 ProductID	* CTL	
158	SDKJ18 ProductID	* CTL	
159	SDKJ19 ProductID	* CTL	
160	SDKJ20 ProductID	* CTL	
161	SDKJ21 ProductID	* CTL	
162	SDKJ22 ProductID	* CTL	
163	SDKJ23 ProductID	* CTL	
164	SDKJ24 ProductID	* CTL	
165	SDKJ25 ProductID	* CTL	
166	SDKJ26 ProductID	* CTL	
167	SDKJ27 ProductID	* CTL	
168	SDKJ28 ProductID	* CTL	
169	SDKJ29 ProductID	* CTL	
170	SDKJ30 ProductID	* CTL	

5404	[User Code Count Clear] (D158/159)		
001	User Code Counter Clear	CTL	Clears all counters for users. [- / - / -] [Execute]

5411	[LDAP-Certification] (D158/159)		
004	Simplified Authentication	* CTL	Turns simple authentication on or off for LDAP. [0 or 1 / 1 / 1/step] 0: OFF, 1: ON

005	Password Null Not Permit	*CTL	This SP is referenced only when SP5411-4 is set to "1" (On). [0 or 1 / 1 / -] 0: Password NULL permitted. 1: Password NULL not permitted.
006	Detail Option	*CTL	Determines whether LDAP option (anonymous certification) is turned on or off. [- / 0x00 / 0x01/step] Bit0 0: OFF, 1: ON

5412	[Access Control] (D158/159)		
	Sets the level of Kerberos Certification.		
100	Encrypt Mode	*CTL	[0x01 to 0xFF / 0x1F / 1bit/step] 0x01:AES256-CTS-HMAC-SHA1-96 0x02:AES128-CTS-HMAC-SHA1-96 0x04:DES3-CBC-SHA1 0x08:RC4-HMAC 0x10:DES-CBC-MD5 0xFF(0x1F):ALL

5413	[Lockout Setting] (D158/159)		
	001	Lockout On/Off	*CTL [0 or 1 / 0 / 1/step] 0: OFF, 1: ON
	Switches on/off the lock on the local address book account.		
002	Lockout Threshold	*CTL	[1 to 10 / 5 / 1time/step]
	Sets a limit on the frequency of lockouts for account lockouts.		

003	Cancellation On/Off	*CTL	[0 or 1 / 0 / 1/step] 0: OFF (lockout not cancelled) 1: ON (system waits, cancels lockout if correct user ID and password are entered)
	Determines whether the system waits the prescribed time for input of a correct user ID and password after an account lockout has occurred.		
004	Cancellation Time	*CTL	[1 to 9999 / 60 / 1 min./step]
	Determines the length of time that the system waits for correct input of the user ID and password after a lockout has occurred. This setting is used only if SP5413-3 is set to "1" (on).		
5414	[Access Mitigation] (D158/159)		
001	Mitigation On/Off	*CTL	[0 or 1 / 0 / 1/step] 0: OFF, 1: ON
	Switches on/off masking of continuously used IDs and passwords that are identical.		
002	Mitigation Time	*CTL	[0 to 60 / 15 / 1 min./step]
	Sets the length of time for excluding continuous access for identical user IDs and passwords.		
5415	[Password Attack] (D158/159)		
001	Permissible Number	*CTL	[0 to 100 / 30 / 1 times/step]
	Sets the threshold number of attempts to attack the system with random passwords to gain illegal access to the system.		
002	Detect Time	*CTL	[1 to 10 / 5 / 1 sec/step]
	Sets a detection time to count a password attack.		
5416	[Access Information] (D158/159)		

001	Access User Max Num	*CTL	[50 to 200 / 200 / 1 users/step]
	Limits the number of users used by the access exclusion and password attack detection functions.		
002	Access Password Num	*CTL	[50 to 200 / 200 / 1/step]
	Limits the number of passwords used by the access exclusion and password attack detection functions.		
003	Monitor Interval	*CTL	[1 to 10 / 3 / 1 sec/step]
	Sets the processing time interval for referencing user ID and password information.		

5417	[Access Attack] (D158/159)		
001	Access Permissible Number	*CTL	[0 to 500 / 100 / 1 times/step]
	Sets a limit on access attempts when an excessive number of attempts are detected for MFP features.		
002	Attack Detect Time	*CTL	[10 to 30 / 10 / 1 sec/step]
	Sets the length of time for monitoring the frequency of access to MFP features.		
003	Productivity Fall Wait	*CTL	[0 to 9 / 3 / 1 sec/step]
	Sets the wait time to slow down the speed of certification when an excessive number of access attempts have been detected.		
004	Attack Max Num	*CTL	[50 to 200 / 200 / 1/step]
	Sets a limit on the number of requests received for certification in order to slow down the certification speed when an excessive number of access attempts have been detected.		

5420	[User Authentication] (D158/159)		
	<p>These settings should be done with the System Administrator.</p> <p> Note</p> <ul style="list-style-type: none"> • These functions are enabled only after the user access feature has been enabled. 		

001	Copy	*CTL	[0 or 1 / 0 / 1/step] 0: Authentication ON 1: Authentication OFF
	Determines whether certification is required before a user can use the copy applications.		
011	DocumentServer	*CTL	[0 or 1 / 0 / 1/step] 0: Authentication ON 1: Authentication OFF
	Determines whether certification is required before a user can use the document server.		
021	Fax	*CTL	[0 or 1 / 0 / 1/step] 0: Authentication ON 1: Authentication OFF
	Determines whether certification is required before a user can use the fax application.		
031	Scanner	*CTL	[0 or 1 / 0 / 1/step] 0: Authentication ON 1: Authentication OFF
	Determines whether certification is required before a user can use the scan applications.		
041	Printer	*CTL	[0 or 1 / 0 / 1/step] 0: Authentication ON 1: Authentication OFF
	Determines whether certification is required before a user can use the printer applications.		
051	SDK1	*CTL	Determines whether certification is required before a user can use the SDK application.
061	SDK2	*CTL	
071	SDK3	*CTL	[0 or 1 / 0 / 1/step] 0: Authentication ON 1: Authentication OFF
081	Browser	*CTL	[0 or 1 / 0 / 1/step] 0: Authentication ON 1: Authentication OFF
	Determines whether certification is required before a user can use the Browser application.		

5430	[Auth Dialog Message Change] (D158/159)		
	Displays the Authentication dialog message or not.		
001	Message Change On/Off	*CTL	[OFF or ON / OFF / 1/step] OFF: Function off. ON: Function on.
	Turns on or off the displayed message change for the authentication.		
002	Message Text Download	CTL	[- / - / -] [Execute]
	Executes the message download for the authentication.		
003	Message Text ID	CTL	[characters(max.16Byte) / \0 /-]
	Inputs message text for the authentication.		
5431	[External Auth User Preset] (D158/159)		

010	Tag	*CTL	[0 or 1 / 1 / 1/step] 0: Not permit, 1: Permit
011	Entry	*CTL	
012	Group	*CTL	
020	Mail	*CTL	
030	Fax	*CTL	
031	FaxSub	*CTL	
032	Folder	*CTL	
033	ProtectCode	*CTL	
034	SmtplAuth	*CTL	
035	LdapAuth	*CTL	
036	Smb Ftp Fldr Auth	*CTL	
037	AcntAcl	*CTL	
038	DocumentAcl	*CTL	
040	CertCrypt	*CTL	
050	UserLimitCount	*CTL	

5481	[Authentication Error Code] (D158/159)		
	These SP codes determine how the authentication failures are displayed.		
001	System Log Disp	*CTL	[0 or 1 / 0 / 1/step] 0: Display OFF 1: Display ON
	Determines whether an error code appears in the system log after a user authentication failure occurs.		
002	Panel Disp	*CTL	[0 or 1 / 0 / 1/step] 0: Display OFF 1: Display ON
	Determines whether an error code appears on the operation panel after a user authentication failure occurs.		

5490	[MF KeyCard] (D158/159)		
	Sets up operation of the machine with a keycard.		
001	Job Permit Setting	*CTL	[0 or 1 / 0 / 1/step] 0: Disabled. Cancels operation without a user code. 1: Enabled. Allows operation without a user code.
5491	[Optional Counter] (D158/159)		
001	Detail Option	*CTL	[- / 0x00 / 0x01/step] bit0: Forced Job Canceling -1:Yes, 2: No
5501	[PM Alarm] (D158/159)		
	[PM Alarm Interval] (D160/D161/D170)		
001	PM Alarm Level (Printout)	*CTL	[0 to 9999 / 0 / 1/step] 0: Alarm off 1 to 9999: Alarm goes off when Value (1 to 9999) x 1000 > PM counter
002	Original Count Alarm (D158/159)	*CTL	[0 or 1 / 0 / 1/step] 0: No alarm sounds 1: Alarm sounds after the number of originals passing through the ARDF > 10,000
5504	[Jam Alarm] (D158/159)		

001	Jam Alarm	*CTL	[0 to 3 / 3 / 1/step] 0: Zero (Off) 1: Low (2.5K jams) 2: Medium (3K jams) 3: High (6K jams)
	Sets the alarm to sound for the specified jam level (document miss feeds are not included).		
5505	[Error Alarm] (D158/159)		
	Sets the error alarm level. The error alarm counter counts "1" when any SC is detected. However, the error alarm counter decreases by "1" when an SC is not detected during a set number of copied sheets (for example, default 2000 sheets). The error alarm occurs when the SC error alarm counter reaches "5".		
001	Error Alarm	*CTL	[0 to 255 / 20 / 1hundred/step]
5507	[Supply Alarm] (D158/159)		
	Enables or disables the notifying a supply call via the @Remote.		
001	Paper Supply Alarm	*CTL	[0 or 1 / 0 / 1/step] 0: OFF, 1: ON
003	Toner Supply Alarm	*CTL	[0 or 1 / 1 / 1/step] 0: OFF, 1: ON
	If you select "1" the alarm will sound when the copier detects toner end.		
080	Toner Call Timing	*CTL	Changes the timing of the "Toner Supply Call" via the @Remote, when the following conditions occur. [0 or 1 / 0 / 1/step] 0: At replacement 1: At near end

128	Interval :Others	*CTL	[250 to 10000 / 1000 / 1 page/step] The "Paper Supply Call Level: nn" SPs specify the paper control call interval for the referenced paper sizes.
132	Interval :A3	*CTL	
133	Interval :A4	*CTL	
134	Interval :A5	*CTL	
141	Interval :B4	*CTL	
142	Interval :B5	*CTL	
160	DLT	*CTL	
166	Interval :LT	*CTL	
172	Interval :HLT	*CTL	

5508	[CC Call] (D158/159)		
001	Jam Remains	*CTL	[0 or 1 / 1 / 1/step] 0: Disable, 1: Enable
	Enables/disables initiating a call for an unattended paper jam.		
002	Continuous Jams	*CTL	[0 or 1 / 1 / 1/step] 0: Disable, 1: Enable
	Enables/disables initiating a call for consecutive paper jams.		
003	Continuous Door Open	*CTL	[0 or 1 / 1 / 1/step] 0: Disable, 1: Enable
	Enables/disables initiating a call when the front door remains open.		
011	Jam Detection: Time Length	*CTL	[3 to 30 / 10 / 1 min./step]
	Sets the time a jam must remain before it becomes an "unattended paper jam". This setting is enabled only when SP5508-004 is set to "1".		
012	Jam Detection: Continuous Count	*CTL	[2 to 10 / 5 / 1 time /step]
	Sets the number of consecutive paper jams required to initiate a call. This setting is enabled only when SP5508-004 is set to "1".		

013	Door Open: Time Length	*CTL	[3 to 30 / 10 / 1 min./step]
	Sets the length of time the door remains open before the machine initiates a call. This setting is enabled only when SP5-508-004 is set to "1".		

5515	[SC/Alarm Setting] (D158/159)	*CTL	-
	With @Remote in use, these SP codes can be set to issue an SC call when an SC error occurs. If this SP is switched off, the SC call is not issued when an SC error occurs.		
001	SC Call	*CTL	[0 or 1 / 1 / 1/step] 0: OFF, 1: ON
002	Service Parts Near End Call	*CTL	
003	Service Parts End Call	*CTL	
004	User Call	*CTL	
006	Communication Test Call	*CTL	
007	Machine Information Notice	*CTL	
008	Alarm Notice	*CTL	
009	Non Genuine Tonner Ararm	*CTL	
010	Supply Automatic Ordering Call	*CTL	
011	Supply Management Report Call	*CTL	
012	Jam/Door Open Call	*CTL	

5713	[Service Blanch Information] (D158/159)		
	Sets the Service Blanch Information Code		
001	Service Blanch Information Code	*CTL	[7digit / - / -/step]

5730	[Extended Function Setting] (D158/159)		
	010	Expiration Prior Alarm Set	*CTL

5731	[Counter Effect] (D158/159)		
001	Change MK1 Cnt (Paper->Combine)	*CTL	[0 or 1 / 0 / 1/step]

5745	[EcoCountTime] (D158/159)		
005	EcoCountTime	*CTL	[0 to 1439 / 0 / -/step]
5745	[PowerConsumption]		
211	Controller Standby	*CTL	[0 to 9999 / 0 / 1/step]
212	STR	*CTL	[0 to 9999 / 0 / 1/step]
213	Main Power Off	*CTL	[0 to 9999 / 0 / 1/step]
214	Scanning and Printing	*CTL	[0 to 9999 / 0 / 1/step]
215	Printing	*CTL	[0 to 9999 / 0 / 1/step]
216	Scanning	*CTL	[0 to 9999 / 0 / 1/step]
217	Engine Standby	*CTL	[0 to 9999 / 0 / 1/step]
218	Low Power Consumption	*CTL	[0 to 9999 / 0 / 1/step]
219	Silent Consumption	*CTL	[0 to 9999 / 0 / 1/step]

5746	[BMLinks] (D158/159)		
001	available	*CTL	[0 or 1 / 1 / 1 /step]
002	Interval: mon	*CTL	[0 to 3600 / 60 / 1 /step]
004	available:log	*CTL	[0 or 1 / 1 / 1 /step]

5747	[JPEG Quality] (D158/159)		
	-		
201	-	*CTL	[0 to 100 / 80 / 1%/step]
203	memory	*CTL	[0 or 1 / 0 / 1/step] 0: Use extended memory 1: Not use extended memory

204	Browser	*CTL	[0 or 1 / 0 / 1/step]
205	Browser2	*CTL	[0 to 3 / 0 / 1/step]
206	Browser3	*CTL	[0 to 255 / 0 / 1/step]

5749	[Import/Export] (D158/159)		
	Imports and exports preference information.		
001	Export	CTL	[- / - / -] Target: System, Printer, Fax, Scanner Option: Unique, Secret Copy config: Encryption, Encryption key(if selected) [Execute]
101	Import	CTL	[- / - / -] Option: Unique Copy config: Encryption, Encryption key(if selected) [Execute]
251	Export Result Print(SP)	CTL	[- / - / -] [Execute]
252	Import Result Print(SP)	CTL	[- / - / -] [Execute]

5792	[MS Debug SW] (D158/159)		
	-		
001	1	CTL	[0 to 255 / - / 1 /step]

5801	[Memory Clear]		
------	-----------------------	--	--

001	All Clear (D158/159)	CTL	[- / - / -] [Execute]
	Resets all correction data for process control and all software counters, and returns all modes and adjustments to their default values.		
002	Engin	ENG	[- / - / -] [Execute]
	Initializes all registration settings for the engine and copy process settings.		
003	SCS (D158/159)	CTL	[- / - / -] [Execute]
	Initializes default system settings, SCS (System Control Service) settings, operation display coordinates, and ROM update information.		
006	Copier Application (D158/159)	CTL	[- / - / -] [Execute]
	Initializes all copier application settings.		
007	FAX Application (D158/159)	CTL	[- / - / -] [Execute]
	Clears the fax application settings.		
008	Printer Application (D158/159)	CTL	[- / - / -] [Execute]
	<p>The following service settings:</p> <ul style="list-style-type: none"> • Bit switches • Gamma settings (User & Service) • Toner Limit <p>The following user settings:</p> <ul style="list-style-type: none"> • Tray Priority • Menu Protect • System Setting except for setting of Energy Saver • I/F Setup (I/O Buffer and I/O Timeout) • PCL Menu 		

009	Scanner Application (D158/159)	CTL	[- / - / -] [Execute]
	Initializes the scanner defaults for the scanner and all the scanner SP modes.		
010	Web Service (D158/159)	CTL	[- / - / -] [Execute]
	Deletes the network file application management files and thumbnails, and initializes the job login ID.		
011	NCS (D158/159)	CTL	[- / - / -] [Execute]
	All setting of Network Setup (User Menu) (NCS: Network Control Service)		
012	R-FAX (D158/159)	CTL	[- / - / -] [Execute]
	Initializes the R-FAX settings.		
014	Clear DCS Setting (D158/159)	CTL	[- / - / -] [Execute]
	Initializes the DCS (Delivery Control Service) settings.		
015	Clear UCS Settings (D158/159)	CTL	[- / - / -] [Execute]
	Initializes the UCS (User Information Control Service) settings.		
016	MIRS Setting (D158/159)	CTL	[- / - / -] [Execute]
	Initializes the MIRS (Machine Information Report Service) settings.		
017	CCS (D158/159)	CTL	[- / - / -] [Execute]
	Initializes the CCS (Certification and Charge-control Service) settings.		

018	SRM (D158/159)	CTL	[- / - / -] [Execute]
	Initializes the SRM (System Resource Manager) settings.		
019	LCS (D158/159)	CTL	[- / - / -] [Execute]
	Initializes the LCS settings.		
020	Web Uapl (D158/159)	CTL	[- / - / -] [Execute]
	Initializes the web user application settings.		
024	BROWSER (D158/159)	CTL	[- / - / -] [Execute]
	Initializes the browser settings.		
025	websys (D158/159)	CTL	[- / - / -] [Execute]

5802	[Machine Free Run] (D160/D161/D170)		
	Starts a free run of both the scanner and the printer. Press "ON" to start; press "OFF" to stop.		
001	Machine Free Run	*ENG	[- / - / -] [Execute]

5803	[INPUT Check] (D158/159)		
001	Tray1: Paper Size Sensor	ENG	[0 to 15 / 0 / 1/step]
002	Tray2: Paper Size Sensor	ENG	[0 to 7 / 0 / 1/step]
003	Tray1: Tray Set Sensor	ENG	[0 or 1 / 0 / 1/step]
004	Tray2: Tray Set Sensor	ENG	[0 or 1 / 0 / 1/step]
009	Tray1: Paper End Sensor	ENG	[0 or 1 / 0 / 1/step]
010	Tray2: Paper End Sensor	ENG	[0 or 1 / 0 / 1/step]

011	Tray1: Paper Lift Sensor	ENG	[0 or 1 / 0 / 1/step]
012	Tray2: Paper Lift Sensor	ENG	[0 or 1 / 0 / 1/step]
015	By-pass: Paper Size Sensor	ENG	[0 to 15 / 0 / 1/step]
016	By-pass: Paper End Sensor	ENG	[0 or 1 / 0 / 1/step]
017	By-pass: Paper Length Sensor	ENG	[0 or 1 / 0 / 1/step]
018	By-pass: Home Position Sensor	ENG	[0 or 1 / 0 / 1/step]
019	Paper Exit Sensor	ENG	[0 or 1 / 0 / 1/step]
020	Paper Feed Sensor1	ENG	[0 or 1 / 0 / 1/step]
021	Paper Feed Sensor2	ENG	[0 or 1 / 0 / 1/step]
022	Registration Sensor	ENG	[0 or 1 / 0 / 1/step]
023	Interchange Sensor	ENG	[0 or 1 / 0 / 1/step]
024	Duplex: Exit Sensor	ENG	[0 or 1 / 0 / 1/step]
025	Duplex: Entrance Sensor	ENG	[0 or 1 / 0 / 1/step]
027	Front Safety Sw-24v	ENG	[0 or 1 / 0 / 1/step]
029	Right Cover Open	ENG	[0 or 1 / 0 / 1/step]
030	Duplex Fan lock	ENG	[0 or 1 / 0 / 1/step]
033	Fan Lock	ENG	[0 or 1 / 0 / 1/step]
035	Main Motor Lock	ENG	[0 or 1 / 0 / 1/step]
037	PCU Set	ENG	[0 or 1 / 0 / 1/step]
039	Key Card Set	ENG	[0 or 1 / 0 / 1/step]
040	Mechanical Counter Set	ENG	[0 or 1 / 0 / 1/step]
041	Key Counter Set	ENG	[0 to 3 / 0 / 1/step]
042	BICU Version	ENG	[0 to 7 / 0 / 1/step]
043	VFEEDCOVER	ENG	[0 or 1 / 0 / 1/step]
071	Bank:CPU-Port2	ENG	[0 to 255 / 0 / 1/step]
072	Bank:CPU-Port3	ENG	[0 to 255 / 0 / 1/step]

073	Bank:CPU-Port A	ENG	[0 to 255 / 0 / 1/step]
074	Bank:CPU-Port B	ENG	[0 to 255 / 0 / 1/step]
200	HP Sensor	ENG	[0 or 1 / 0 / 1/step]
201	Platen Cover Sensor	ENG	[0 or 1 / 0 / 1/step]

5803	[Input Check] (D160/D161/D170)		
001	Safety SW	ENG	[0x00 to 0xFF / 0 / 1/step] 0:OFF 1:ON
002	Safety SW-LD5V	ENG	[0x00 to 0xFF / 0 / 1/step] 0:OFF 1:ON
003	Right Cover SW	ENG	[0x00 to 0xFF / 0 / 1/step] 0:CLOSE 1:OPEN
004	Right LowCover SW	ENG	[0x00 to 0xFF / 0 / 1/step] 0:CLOSE 1:OPEN
006	Upper Relay S	ENG	[0x00 to 0xFF / 0 / 1/step] 0:Not detected 1:Paper detected
007	Lower Relay S	ENG	[0x00 to 0xFF / 0 / 1/step] 0:Not detected 1:Paper detected
009	Regist Sensor	ENG	[0x00 to 0xFF / 0 / 1/step] 0:Not detected 1:Paper detected
010	Exit Sensor	ENG	[0x00 to 0xFF / 0 / 1/step] 0:Not detected 1:Paper detected

011	Duplex Inverter S	ENG	[0x00 to 0xFF / 0 / 1/step] 0:Not detected 1:Paper detected
012	Duplex Entrance S	ENG	[0x00 to 0xFF / 0 / 1/step] 0:Not detected 1:Paper detected
013	Duplex Exit S	ENG	[0x00 to 0xFF / 0 / 1/step] 0:Not detected 1:Paper detected
014	Bypass PE S	ENG	[0x00 to 0xFF / 0 / 1/step] 0:Not detected 1:Paper detected
015	Bypass P Size S	ENG	[0x00 to 0xFF / 0 / 1/step] Refer to *5
016	Upper PE S	ENG	[0x00 to 0xFF / 0 / 1/step] 0:Not detected 1:Paper detected
017	Lower PE S	ENG	[0x00 to 0xFF / 0 / 1/step] 0:Not detected 1:Paper detected
018	Upper P Size SW	ENG	[0x00 to 0xFF / 0 / 1/step] Refer to *5
019	Lower P Size SW	ENG	[0x00 to 0xFF / 0 / 1/step] Refer to *5
032	Main M Lock	ENG	[0x00 to 0xFF / 0 / 1/step] 0:Not locked 1:Locked
033	Polygon M Lock	ENG	[0x00 to 0xFF / 0 / 1/step] 0:Not locked 1:Locked

035	Total CO Install	ENG	[0x00 to 0xFF / 0 / 1/step] 0:Unconnected 1:Connected
036	Key CO Install	ENG	[0x00 to 0xFF / 0 / 1/step] 0:Unconnected 1:Connected
037	L-Synchronization	ENG	[0x00 to 0xFF / 0 / 1/step] 0:Undetected 1:Detected
045	Platen Cover S	ENG	[0x00 to 0xFF / 0 / 1/step] 0:CLOSE 1:OPEN
050	Fan Motor Lock	ENG	[0x00 to 0xFF / 0 / 1/step] 0:*6Lock 1:Unlocked
051	2 Tray BK Install	ENG	[0x00 to 0xFF / 0 / 1/step] 0:Not Connected 1:Connected
053	HP Sensor	ENG	[0x00 to 0xFF / 0 / 1/step] 0:Not Detected 1:Detected
054	Duplex Fan M Lock	ENG	[0x00 to 0xFF / 0 / 1/step] 0:*6Lock 1:Unlocked
055	Tray1: Tray Set	ENG	[0x00 to 0xFF / 0 / 1/step] 0:Unset 1:Set
056	Tray2: Tray Set	ENG	[0x00 to 0xFF / 0 / 1/step] 0:Unset 1:Set

057	Tray1: Paper Lift	ENG	[0x00 to 0xFF / 0 / 1/step] 0:Not Maximum 1:Maximum
058	Tray2: Paper Lift	ENG	[0x00 to 0xFF / 0 / 1/step] 0:Not Maximum 1:Maximum
059	Bypass: Length	ENG	[0x00 to 0xFF / 0 / 1/step] 0:Not Detected 1:Paper Detected
060	Bypass: HP	ENG	[0x00 to 0xFF / 0 / 1/step] 0:Not Lifted 1:Lifted
061	Key Card Install	ENG	[0x00 to 0xFF / 0 / 1/step] 0:Unconnected 1:Connected
071	Bank:CPU-Port2	ENG	[0x00 to 0xFF / 0 / 1/step] 0:*7 1:
072	Bank:CPU-Port3	ENG	[0x00 to 0xFF / 0 / 1/step] 0:*8 1:
073	Bank:CPU-PortA	ENG	[0x00 to 0xFF / 0 / 1/step] 0:*9 1:
074	Bank:CPU-PortB	ENG	[0x00 to 0xFF / 0 / 1/step] 0:*10 1:
080	ADF Lift Up	ENG	[0x00 to 0xFF / 0 / 1/step] 0:CLOSE 1:OPEN

081	ADF Feed Cover	ENG	[0x00 to 0xFF / 0 / 1/step] 0:CLOSE 1:OPEN
082	ADF Original Set	ENG	[0x00 to 0xFF / 0 / 1/step] 0:Not Detected 1:Paper Detected
083	ADF Registration	ENG	[0x00 to 0xFF / 0 / 1/step] 0:Not Detected 1:Paper Detected
084	ADF Exit Sensor	ENG	[0x00 to 0xFF / 0 / 1/step] 0:Not Detected 1:Paper Detected
085	ADF Rear Edge	ENG	[0x00 to 0xFF / 0 / 1/step] 0:No Paper Detected 1:Paper Detected
086	ADF Org Length1	ENG	[0x00 to 0xFF / 0 / 1/step] 0:* 11 1:
087	ADF Org Length2	ENG	[0x00 to 0xFF / 0 / 1/step] * 11
088	ADF Org Length3	ENG	[0x00 to 0xFF / 0 / 1/step] 0:* 11 1:
089	ADF Org Width1	ENG	[0x00 to 0xFF / 0 / 1/step] 0:* 11 1:
090	ADF Org Width2	ENG	[0x00 to 0xFF / 0 / 1/step] 0:* 11 1:

091	ADF Org Width3	ENG	[0x00 to 0xFF / 0 / 1/step] 0:*11 1:
092	ADF Org Width4	ENG	[0x00 to 0xFF / 0 / 1/step] 0:*11 1:
093	ADF Skew Correct	ENG	[0x00 to 0xFF / 0 / 1/step] 0:Not Detected 1:Paper Detected

*5 Size code for PFU (Paper feed unit) / By-pass tray

PFU	00	01	02	03	04	05	06	07
EU	LTT	B5T	HLTY	A3T	A4T	B5Y	A4Y	B4T
NA	LTT	B5T	A5Y	DLTT	A4T	Exe	LTY	LGT

By-pass Tray	00	01	02	03	04	05	06	07	08	09	0C	0D	10	11	18	19
EU	A5T	A5T	B5T	B5Y	B4Y	B4T	A5Y	A4T	A5T	A5T	A4Y	A3T	A5T	A5T	B6T	B6T
NA	HLTT	HLTT	LTS/LG	LTS/G	LY	DLT	LTS/LG	LTS/LG	HLTT	HLTT	LY	DLT	HLTT	HLTT	HLTT	HLTT

*6 Fan motor lock

Only available with High speed revolution.

(Can not refer with Low speed or Stop)

*7 Bank:CPU-Port2

Display CPU port infos "****" of [80 **H] from Bank with 8bit.

*8 Bank:CPU-Port3

Display CPU port infos "****" of [81 **H] from Bank with 8bit.

*9 Bank:CPU-PortA

Display CPU port infos "****" of [82 **H] from Bank with 8bit.

* 10 Bank:CPU-PortB

Display CPU port infos """" of [83 * * H] from Bank with 8bit.

* 11 ADF: Combination of detect sensor for Org Length/ Org Width.

Size (W*L)	Width detect sensor				On table sensor		
	1	2	3	4	B5	A4	LG
A3 vertical (297*420)	YES	YES	YES	YES	YES	YES	YES
B4 vertical (257*364)	YES	YES	-	-	YES	YES	YES
A4 vertical (210/297)	YES	-	-	-	YES	YES	-
A4 landscape (297*210)	YES	YES	YES	YES	-	-	-
B5 vertical (182*257)	-	-	-	-	YES	-	-
B5 landscape (257*182)	YES	YES	-	-	-	-	-
A5 vertical (148*210)	-	-	-	-	-	-	-
A5 landscape (210*148)	YES	-	-	-	-	-	-
11"*17" (DLT) vertical	YES	YES	YES	-	YES	YES	YES
11"*15" vertical	YES	YES	YES	-	YES	YES	YES
10"*14" vertical	YES	YES	-	-	YES	YES	YES
8 1/2"*14"(LG) vertical	YES	-	-	-	YES	YES	YES
8 1/2"*13" (F4) *2 vertical	YES	-	-	-	YES	YES	YES
8 1/4"*13" vertical *	YES	-	-	-	YES	YES	YES
8"*13" (F) * Vertical	YES	-	-	-	YES	YES	YES
8 1/2"*11" (LT) vertical	YES	-	-	-	YES	-	-
11"*8 1/2" (LT) Landscape	YES	YES	YES	-	-	-	-

7 1/4" * 10 1/2" (US EXE) vertical	YES	-	-	-	YES	-	-
10 1/2" * 7 1/4" (US EXE) landscape	YES	YES	YES	-	-	-	-
8" * 10" vertical	YES	-	-	-	YES	-	-
5 1/2" * 8 1/2" (HLT) vertical	-	-	-	-	-	-	-
8 1/2" * 5 1/2" (HLT) landscape	YES	-	-	-	-	-	-
8K vertical (267*390)	YES	YES	YES	-	YES	YES	YES
16K vertical (195*267)	YES	-	-	-	YES	-	-
16K landscape(267*195)	YES	YES	YES	-	-	-	-

5804	[OUTPUT Check] (D158/D159)		
001	Main Motor: CW: High	ENG	[0 or 1 / 0 / 1/step]
002	Main Motor: CW: Low	ENG	[0 or 1 / 0 / 1/step]
003	Main Motor: CCW: High	ENG	[0 or 1 / 0 / 1/step]
004	Main Motor: CCW: Low	ENG	[0 or 1 / 0 / 1/step]
005	Duplex Motor: HOLD	ENG	[0 or 1 / 0 / 1/step]
006	Duplex Motor: CCW: 582.4	ENG	[0 or 1 / 0 / 1/step]
007	Duplex Motor: CCW: 636.6	ENG	[0 or 1 / 0 / 1/step]
008	Duplex Motor: CCW: 708.5	ENG	[0 or 1 / 0 / 1/step]
009	Duplex Motor: CCW: 774.8	ENG	[0 or 1 / 0 / 1/step]
010	Interchange Motor: HOLD	ENG	[0 or 1 / 0 / 1/step]
011	Interchange Motor: CW:430.1	ENG	[0 or 1 / 0 / 1/step]
012	Interchange Motor: CW:524.5	ENG	[0 or 1 / 0 / 1/step]

013	Interchange Motor: CCW: 430.1	ENG	[0 or 1 / 0 / 1/step]
014	Interchange Motor: CCW: 474.3	ENG	[0 or 1 / 0 / 1/step]
015	Interchange Motor: CCW: 524.5	ENG	[0 or 1 / 0 / 1/step]
016	Interchange Motor: CCW: 577.3	ENG	[0 or 1 / 0 / 1/step]
020	Toner Bottle Motor	ENG	[0 or 1 / 0 / 1/step]
021	1st Tray Up	ENG	[0 or 1 / 0 / 1/step]
022	1st Tray Down	ENG	[0 or 1 / 0 / 1/step]
023	2nd Tray Up	ENG	[0 or 1 / 0 / 1/step]
024	2nd Tray Down	ENG	[0 or 1 / 0 / 1/step]
025	Exhaust Fan Motor: High	ENG	[0 or 1 / 0 / 1/step]
026	Exhaust Fan Motor: Low	ENG	[0 or 1 / 1 / 1/step]
027	Duplex Fan	ENG	[0 or 1 / 0 / 1/step]
032	Registration CL	ENG	[0 or 1 / 0 / 1/step]
033	1st Paper Feed CL	ENG	[0 or 1 / 0 / 1/step]
034	2nd Paper Feed CL	ENG	[0 or 1 / 0 / 1/step]
035	Paper Tranort CL1	ENG	[0 or 1 / 0 / 1/step]
039	Interchange SOL	ENG	[0 or 1 / 0 / 1/step]
040	Fusing SOL	ENG	[0 or 1 / 0 / 1/step]
041	Dehumidification Heater	ENG	[0 or 1 / 0 / 1/step]
042	PP:Image Transfer: -	ENG	[0 or 1 / 0 / 1/step]
043	PP:Image Transfer: +	ENG	[0 or 1 / 0 / 1/step]
044	Separation Voltage	ENG	[0 or 1 / 0 / 1/step]

045	PP:Developement	ENG	[0 or 1 / 0 / 1/step] 0:OFF, 1:ON
046	PP:Charge	ENG	[0 or 1 / 0 / 1/step]
047	P Sensor	ENG	[0 or 1 / 0 / 1/step]
048	Anti-static LED	ENG	[0 or 1 / 0 / 1/step] 0:OFF, 1:ON
049	Polygon Motor: High	ENG	[0 or 1 / 0 / 1/step] 0:OFF, 1:ON
050	Polygon Motor: Low	ENG	[0 or 1 / 0 / 1/step] 0:OFF, 1:ON
051	LD On	ENG	[0 or 1 / 0 / 1/step] 0:OFF, 1:ON
055	By-pass CL	ENG	[0 or 1 / 0 / 1/step] 0:OFF, 1:ON
056	By-pass Tray CL	ENG	[0 or 1 / 0 / 1/step] 0:OFF, 1:ON
071	Bank: Motor	ENG	[0 or 1 / 0 / 1/step]
072	Bank: Feed Clutch1	ENG	[0 or 1 / 0 / 1/step] 0:OFF, 1:ON
073	Bank: Feed Clutch2	ENG	[0 or 1 / 0 / 1/step] 0:OFF, 1:ON
074	Bank:Trans Clutch	ENG	[0 or 1 / 0 / 1/step]
202	Scanner Lamp	ENG	[0 or 1 / 0 / 1/step]

5804	[OUTPUT Check] (D160/D161/D170)		
001	Main M-Fwd	ENG	[0 or 1 / 0 / 1 / step]
002	Main M-Rev	ENG	[0 or 1 / 0 / 1 / step]
003	Quenching Lamp	ENG	[0 or 1 / 0 / 1 / step]

004	Toner Sup M-Fwd	ENG	[0 or 1 / 0 / 1 / step]
005	Fan M-High	ENG	[0 or 1 / 0 / 1 / step]
006	Fan M-Low	ENG	[0 or 1 / 0 / 1 / step]
007	Registration CL	ENG	[0 or 1 / 0 / 1 / step]
008	Bypass Feed CL	ENG	[0 or 1 / 0 / 1 / step]
009	Upper Feed CL	ENG	[0 or 1 / 0 / 1 / step]
010	Lower Feed CL	ENG	[0 or 1 / 0 / 1 / step]
011	BK-Low Lift M-Up	ENG	[0 or 1 / 0 / 1 / step]
012	BK-Low Lift M-Dw	ENG	[0 or 1 / 0 / 1 / step]
013	Relay CL	ENG	[0 or 1 / 0 / 1 / step]
014	BK-Relay CL	ENG	[0 or 1 / 0 / 1 / step]
015	BK-Upper Feed CL	ENG	[0 or 1 / 0 / 1 / step]
016	BK-Lower Feed CL	ENG	[0 or 1 / 0 / 1 / step]
017	BK-Lift M	ENG	[0 or 1 / 0 / 1 / step]
018	BK-Up Lift M-Up	ENG	[0 or 1 / 0 / 1 / step]
019	BK-Up Lift M-Dw	ENG	[0 or 1 / 0 / 1 / step]
020	Duplex Inv M-Rev	ENG	[0 or 1 / 0 / 1 / step]
021	Duplex Inv M-Fwd	ENG	[0 or 1 / 0 / 1 / step]
022	Duplex Trans M	ENG	[0 or 1 / 0 / 1 / step]
023	Duplex Gate SOL	ENG	[0 or 1 / 0 / 1 / step]
024	Duplex Inv M-Hold	ENG	[0 or 1 / 0 / 1 / step]
025	Dup Trans M-Hold	ENG	[0 or 1 / 0 / 1 / step]
026	Polygon M	ENG	[0 or 1 / 0 / 1 / step]
027	Polygon M/LD	ENG	[0 or 1 / 0 / 1 / step]
038	Fusing SOL	ENG	[0 or 1 / 0 / 1 / step]
040	Duplex Fan M-High	ENG	[0 or 1 / 0 / 1 / step]

041	Duplex Fan M-Low	ENG	[0 or 1 / 0 / 1 / step]
042	1st Tray Up	ENG	[0 or 1 / 0 / 1 / step]
043	1st Tray Down	ENG	[0 or 1 / 0 / 1 / step]
044	2nd Tray Up	ENG	[0 or 1 / 0 / 1 / step]
045	2nd Tray Down	ENG	[0 or 1 / 0 / 1 / step]
046	Bypass Tray CL	ENG	[0 or 1 / 0 / 1 / step]
071	Bank:Motor	ENG	[0 or 1 / 0 / 1 / step]
072	Bank:Feed Clutch1	ENG	[0 or 1 / 0 / 1 / step]
073	Bank:Feed Clutch2	ENG	[0 or 1 / 0 / 1 / step]
074	Bank:Trans Clutch	ENG	[0 or 1 / 0 / 1 / step]
080	ADF Feed Motor F	ENG	[0 or 1 / 0 / 1 / step]
081	ADF Relay Motor F	ENG	[0 or 1 / 0 / 1 / step]
082	ADF Feed Clutch	ENG	[0 or 1 / 0 / 1 / step]
083	ADF Inverter Sol	ENG	[0 or 1 / 0 / 1 / step]
084	ADF Feed Motor R	ENG	[0 or 1 / 0 / 1 / step]
085	ADF Relay Motor R	ENG	[0 or 1 / 0 / 1 / step]
086	ADF Feed Solenoid	ENG	[0 or 1 / 0 / 1 / step]
087	ADF Stamp	ENG	[0 or 1 / 0 / 1 / step]
202	Scanner Light:C	ENG	[0 or 1 / 0 / 1 / step]
203	Scanner Light:BW	ENG	[0 or 1 / 0 / 1 / step]

5807	[Area Selection] (D160/D161/D170)		
	Selects the display language. 2 North America, 3 Europe, 5 Asia, 6 China SP5-807-001 is not cleared by SP5-801-002. Note <ul style="list-style-type: none"> SC982 is displayed if you specify a language that is inconsistent with your local model. 		
001	-	*ENG	[1 to 7 / 0 / 1 / step]

5810	[SC Reset] (D158/159)		
	Resets a type A service call condition. Note <ul style="list-style-type: none"> Turn the main switch off and on after resetting the SC code. 		
0001	Fusing SC Reset	ENG	[- / - / -] [Execute]

5811	[MachineSerial] (D158/159)		
	Machine Serial Number Display		
001	Set BICU	*ENG	[0 to 255 / 0 / 1/step]
002	Display BICU	*ENG	[0 to 255 / 0 / 1/step]
	Displays the machine serial number.		
004	Set EEPROM	ENG	[0 to 255 / 0 / 1/step]
	Inputs		
005	Display: Novita	ENG	[0 to 255 / 0 / 1/step]
	Inputs		

5811	[Serial Num Input] (D160/D161/D170)		
	Inputs 11 digits serial number (machine code + 7-digit serial number).		

001	Code Set	ENG	
-----	----------	-----	--

5812	[Service Tel. No. Setting] (D158/159)		
001	Service	*CTL	[up to 20 / - / 1/step]
	Sets the telephone number for a service representative. This number is printed on the Counter List, which can be printed with the user's "Counter" menu. This can be up to 20 characters (both numbers and alphabetic characters can be input).		
002	Facsimile	*CTL	[up to 20 / - / 1/step]
	Sets the fax or telephone number for a service representative. This number is printed on the Counter List. This can be up to 20 characters (both numbers and alphabetic characters can be input).		
003	Supply	*CTL	[up to 20 / - / 1/step]
	Use this to input the telephone number of your supplier for consumables. Enter the number and press #.		
004	Operation	*CTL	[up to 20 / - / 1/step]
	Use this to input the telephone number of your sales agency. Enter the number and press #.		

5812	[Service TEL] (D160/D161/D170)		
001	Telephone	CTL	[- / - / -]
	Inputs the telephone number of the CE (displayed when a service call condition occurs.)		
002	Facsimile	CTL	[- / - / -]
	Use this to input the fax number of the CE printed on the Counter Report (UP mode).		

5816	[Remote Service] (D158/159)		
001	I/F Setting	*CTL	[0 to 2 / 2 / 1/step] 0: Remote service off 1: CSS remote service on 2: NRS remote service on
	Selects the remote service setting.		

002	CE Call	*CTL	[0 or 1 / 0 / 1/step] 0: Start of the service 1: End of the service
	Performs the CE Call at the start or end of the service.  Note <ul style="list-style-type: none"> This SP is activated only when SP 5816-001 is set to "2". 		
003	Function Flag	*CTL	[0 or 1 / 0 / 1/step] 0: Disabled, 1: Enabled
	Enables or disables the remote service function.		
007	SSL Disable	*CTL	[0 or 1 / 0 / 1/step] 0: No. SSL used. 1: Yes. SSL not used.
	Controls if RCG (Remote Communication Gate) confirmation is done by SSL during an RCG send for the @Remote over a network interface.		
008	RCG Connect Timeout	*CTL	[1 to 90 / 30 / 1second/step]
	Sets the length of time (seconds) for the time-out when the RCG (Remote Communication Gate) connects during a call via the @Remote network.		
009	RCG Write Timeout	*CTL	[0 to 100 / 60 / 1second/step]
	Sets the length of time (seconds) for the time-out when sent data is written to the RCG during a call over the @Remote network.		
010	RCG Read Timeout	*CTL	[0 to 100 / 60 / 1second/step]
	Sets the length of time (seconds) for the timeout when sent data is written from the RCG during a call over the @Remote network.		
011	Port 80 Enable	*CTL	[0 or 1 / 0 / 1/step] 0: No. Access denied 1: Yes. Access granted.
	Controls if permission is given to get access to the SOAP method over Port 80 on the @Remote network.		

013	RFU Timing	*CTL	[0 or 1 / 1 / 1/step] 0: Any status of a target machine 1: Sleep or panel off mode only
	Selects the timing for the remote firmware updating.		
014	RCG Error Cause	CTL	[0 or 1 / 0 / 1/step] 0: Initial state, normal condition 1: Error
	Displays RCG connection error. cause		
021	RCG-C Registered	*CTL	[0 or 1 / 0 / 1/step] 0: Installation not completed 1: Installation completed
	This SP displays the RCG-N installation end flag.		
023	Connect Type (N/M)	*CTL	[0 or 1 / 0 / 1/step] 0: Internet connection 1: Dial-up connection
	This SP displays and selects the RCG-N connection method.		
061	Cert Expire Timing	*CTL	[0 to 0xffffffff / 0 / 1/step]
	Proximity of the expiration of the certification.		
062	Use Proxy	*CTL	[0 or 1 / 0 / 1/step] 0: Not use 1: Use
	This SP setting determines if the proxy server is used when the machine communicates with the service center.		

063	Proxy Host	*CTL	[up to 127 / - / 1/step]
	<p>This SP sets the address of the proxy server used for communication between the RCG device and the gateway. Use this SP to set up or display the customer proxy server address.</p> <p>The address is necessary to set up the embedded RCG-N.</p> <p>Note</p> <ul style="list-style-type: none"> The address display is limited to 128 characters. Characters beyond the 128 character are ignored. This address is customer information and is not printed in the SMC report. 		
064	Proxy Port Number	*CTL	[0 to 0xffff / 0 / 1/step]
	<p>This SP sets the port number of the proxy server used for communication between the embedded RCG-N and the gateway. This setting is necessary to set up the embedded RC Gate-N.</p> <p>Note</p> <ul style="list-style-type: none"> This port number is customer information and is not printed in the SMC report. 		
065	Proxy User Name	*CTL	[up to 31 / - / 1/step]
	<p>This SP sets the HTTP proxy certification user name.</p> <p>Note</p> <ul style="list-style-type: none"> The length of the name is limited to 31 characters. Any character beyond the 31st character is ignored. This name is customer information and is not printed in the SMC report. 		
066	Proxy Password	*CTL	[up to 31 / - / 1/step]
	<p>This SP sets the HTTP proxy certification password.</p> <p>Note</p> <ul style="list-style-type: none"> The length of the password is limited to 31 characters. Any character beyond the 31st character is ignored. This name is customer information and is not printed in the SMC report. 		

	CERT: Up State	*CTL	[0 to 255 / 0 / 1/step]
	Displays the status of the certification update.		
	0	The certification used by Embedded RC Gate is set correctly.	
	1	The certification request (setAuthKey) for update has been received from the GW URL and certification is presently being updated.	
	2	The certification update is completed and the GW URL is being notified of the successful update.	
	3	The certification update failed, and the GW URL is being notified of the failed update.	
	4	The period of the certification has expired and new request for an update is being sent to the GW URL.	
	11	A rescue update for certification has been issued and a rescue certification setting is in progress for the rescue GW connection.	
067	12	The rescue certification setting is completed and the GW URL is being notified of the certification update request.	
	13	The notification of the request for certification update has completed successfully, and the system is waiting for the certification update request from the rescue GW URL.	
	14	The notification of the certification request has been received from the rescue GW controller, and the certification is being stored.	
	15	The certification has been stored, and the GW URL is being notified of the successful completion of this event.	
	16	The storing of the certification has failed, and the GW URL is being notified of the failure of this event.	
	17	The certification update request has been received from the GW URL, the GW URL was notified of the results of the update after it was completed, but a certification error has been received, and the rescue certification is being recorded.	
	18	The rescue certification of No. 17 has been recorded, and the GW URL is being notified of the failure of the certification update.	

068	CERT: Error	*CTL	[0 to 255 / 0 / 1/step]
	Displays a number code that describes the reason for the request for update of the certification.		
	0	Normal. There is no request for certification update in progress.	
	1	Request for certification update in progress. The current certification has expired.	
	2	An SSL error notification has been issued. Issued after the certification has expired.	
	3	Notification of shift from a common authentication to an individual certification.	
	4	Notification of a common certification without ID2.	
	5	Notification that no certification was issued.	
6	Notification that GW URL does not exist.		
069	CERT:Up ID	*CTL	[- / - / -]
	The ID of the request for certification.		
083	Firm Up Status	*CTL	[0 to 5 / 0 / 1/step] 0: waiting for receiving firmware update. 1: waiting for scheduling firmware update start. 2: waiting for user confirmation 3: preparing for device firmware update. 4: processing device firmware update. 5: termination processing
	Displays the status of the firmware update		
085	Firm Up User Check	*CTL	[- / - / -]
	This SP setting determines if the operator can confirm the previous version of the firmware before the firmware update execution. If the option to confirm the previous version is selected, a notification is sent to the system manager and the firmware update is done with the firmware files from the URL.		
086	Firmware Size	*CTL	[- / - / -]
	Allows the service technician to confirm the size of the firmware data files during the firmware update execution.		

087	CERT:Macro Ver.	CTL	[8digits / - / 1digit/step]
	Displays the macro version of the @Remote certification. This SP displays 8-digit characters.		
088	CERT:PAC Ver.	CTL	[16digits / - / 1digit/step]
	Displays the PAC version of the @Remote certification. This SP displays 16-digit characters.		
089	CERT:ID2Code	CTL	[17digits / - / 1digit/step]
	Displays ID2 for the @Remote certification. Spaces are displayed as underscores (_). Asterisks (***) indicate that no @Remote certification exists. This SP displays 17-digit characters.		
090	CERT:Subject	CTL	[17digits / - / 1digit/step]
	Displays the common name of the @Remote certification subject. CN = the following 17 bytes. Spaces are displayed as underscores (_). Asterisks (***) indicate that no DESS exists.		
091	CERT:Serial No.	CTL	[16digits / - / 1digit/step]
	Displays serial number for the NRS certification. Asterisks (***) indicate that no DESS exists. This SP displays 16-digit characters		
092	CERT:Issuer	CTL	[30digits / - / 1digit/step]
	Displays the common name of the issuer of the @Remote certification. CN = the following 30 bytes. Asterisks (***) indicate that no DESS exists.		
093	CERT:Valid Start	CTL	[10digits / - / 1digit/step]
	Displays the start time of the period for which the current @Remote certification is enabled. This SP displays 10-digit characters.		
094	CERT:Valid End	CTL	[10digits / - / 1digit/step]
	Displays the end time of the period for which the current @Remote certification is enabled. This SP displays 10-digit characters.		
102	CERT:Encrypt Level	*CTL	[1 or 2 / 1 / 1/step] 1: 512 bit 2: 2048 bit
	Displays cryptic strength of the NRS certification.		

150	Selection Country	*CTL	[0 to 10 / 1 / 1/step] 0: Japan, 1: USA, 2: Canada, 3: UK, 4: Germany, 5: France, 6: Italy, 7: Netherlands, 8: Belgium, 9: Luxembourg, 10: Spain
	<p>Select the country where embedded RCG-M is installed in the machine. After selecting the country, you must also set the following SP codes for embedded RCG-M:</p> <ul style="list-style-type: none"> • SP5816-153 • SP5816-154 • SP5816-161 		
151	Line Type Automatic Judgement	CTL	[- / - / -] [Execute]
	<p>Setting this SP classifies the telephone line where embedded RCG-M is connected as either dial-up (pulse dial) or push (DTMF tone) type, so embedded RCG-M can automatically distinguish the number that connects to the outside line.</p> <ul style="list-style-type: none"> • The current progress, success, or failure of this execution can be displayed with SP5816-152. • If the execution succeeded, SP5816-153 will display the result for confirmation and SP5816-154 will display the telephone number for the connection to the outside line. 		

152	Line Type Judgement Result	CTL	[0 to 255 / 0 / 1/step]
<p>Displays a number to show the result of the execution of SP5816-151. Here is a list of what the numbers mean.</p> <p>0: Success</p> <p>1: In progress (no result yet). Please wait.</p> <p>2: Line abnormal</p> <p>3: Cannot detect dial tone automatically</p> <p>4: Line is disconnected</p> <p>5: Insufficient electrical power supply</p> <p>6: Line classification not supported</p> <p>7: Error because fax transmission in progress – ioctl() occurred.</p> <p>8: Other error occurred</p> <p>9: Line classification still in progress. Please wait.</p>			
153	Selection Dial / Push	*CTL	<p>[0 or 1 / 0 / 1/step]</p> <p>0: Tone Dialing Phone</p> <p>1: Pulse Dialing Phone</p> <p>Inside Japan "2" may also be displayed:</p> <p>0: Tone Dialing Phone</p> <p>1: Pulse Dialing Phone 10PPS</p> <p>2: Pulse Dialing Phone 20PPS</p>
<p>This SP displays the classification (tone or pulse) of the telephone line to the access point for embedded RCG-M. The number displayed (0 or 1) is the result of the execution of SP5816-151. However, this setting can also be changed manually.</p>			

154	Outside Line Outgoing Number	*CTL	[4digits / - / 1 digit/step]
	<p>The SP sets the number that switches to PSTN for the outside connection for embedded RCG-M in a system that employs a PBX (internal line).</p> <ul style="list-style-type: none"> • If the execution of SP5816-151 has succeeded and embedded RCG-M has connected to the external line, this SP display is completely blank. • If embedded RCG-M has connected to an internal line, then the number of the connection to the external line is displayed. • If embedded RCG-M has connected to an external line, a comma is displayed with the number. The comma is inserted for a 2 sec. pause. • The number setting for the external line can be entered manually (including commas). 		
155	PPPConnectTimeout	*CTL	[1 to 65536 / 60 / 1 / step]
	Modifies connection timeout when RCG-M is accessing to PPP.		
156	Dial Up User Name	*CTL	[up to 32 char. / - / -/step]
	<p>Use this SP to set a user name for access to remote dial up. Follow these rules when setting a user name:</p> <ul style="list-style-type: none"> • Name length: Up to 32 characters • Spaces and # allowed but the entire entry must be enclosed by double quotation marks (""). 		
157	Dial Up Password	*CTL	up to 32 char.
	<p>Use this SP to set a password for access to remote dial up. Follow these rules when setting a user name:</p> <ul style="list-style-type: none"> • Name length: Up to 32 characters • Spaces and # allowed but the entire entry must be enclosed by double quotation marks (""). 		
161	Local Phone Number	*CTL	up to 24 numbers
	Use this SP to set the telephone number of the line where embedded RCG-M is connected. This number is transmitted to and used by the Call Center to return calls. Limit: 24 numbers (numbers only)		

162	Connection Timing Adjustment Incoming	*CTL	[0 to 24 / 1 / 1/step]
	<p>When the Call Center calls out to an embedded RCG-M modem, it sends a repeating ID tone (*#1#). This SP sets the time the line remains open to send these ID tones after the number of the embedded RCG-M modem is dialed up and connected.</p> <p>The actual amount of time is this setting x 2 sec. For example, if you set "2" the line will remain open for 4 sec.</p>		
163	Access Point	*CTL	up to 16 char.
	<p>This is the number of the dial-up access point for RCG-M. If no setting is done for this SP code, then a preset value (determined by the country selected) is used.</p> <p>Default: 0</p> <p>Allowed: Up to 16 alphanumeric characters</p>		
164	Line Connecting	*CTL	[0 to 1 / 0 / 1/step] 0: Sharing Fax 1: No Sharing Fax
	<p>This SP sets the connection conditions for the customer. This setting dedicates the line to RCG-M only, or sets the line for sharing between RCG-M and a fax unit.</p> <p>Note</p> <ul style="list-style-type: none"> • If this setting is changed, the copier must be cycled off and on. • SP5816187 determines whether the off-hook button can be used to interrupt a RCG-M transmission in progress to open the line for fax transaction. 		
173	Modem Serial No.	*CTL	[- / - / -]
	<p>This SP displays the serial number registered for the RCG-M.</p>		
174	Retransmission Ringing	CTL	[- / - / -] [Execute]
	<p>Normally, it is best to allow unlimited time for certification and ID2 update requests, and for the notification that the certification has been completed. However, RCG-M generates charges based on transmission time for the customer, so a limit is placed upon the time allowed for these transactions.</p> <p>If these transactions cannot be completed within the allowed time, do this SP to cancel the time restriction.</p>		

200	Manual Polling	CTL	[- / - / -] [Execute]
	Executes the center polling manually.		
201	Regist Status	CTL	[0 to 4 / 0 / 1/step]
	<p>Displays a number that indicates the status of the @Remote service device.</p> <p>0: Neither the registered device by the external nor embedded RCG device is set.</p> <p>1: The embedded RCG device is being set. Only Box registration is completed. In this status, this unit cannot answer a polling request from the external RCG.</p> <p>2. The embedded RCG device is set. In this status, the external RCG unit cannot answer a polling request.</p> <p>3. The registered device by the external RCG is being set. In this status the embedded RCG device cannot be set.</p> <p>4 The registered module by the external RCG has not started.</p>		
202	Letter Number	*CTL	[- / - / -]
	Allows entering the number of the request needed for the RCG-N device.		
203	Confirm Execute	CTL	[- / - / -] [Execute]
	Executes the inquiry request to the @Remote GW URL.		
204	Confirm Result	CTL	[0 to 255 / 0 / 1/step]
	<p>Displays a number that indicates the result of the inquiry executed with SP5816 203.</p> <p>0: Succeeded</p> <p>1: Inquiry number error</p> <p>3: Proxy error (proxy enabled)</p> <p>4: Proxy error (proxy disabled)</p> <p>5: Proxy error (Illegal user name or password)</p> <p>6: Communication error</p> <p>8: Other error</p> <p>9: Inquiry executing</p>		
205	Confirm Place	CTL	[- / - / -]
	Displays the result of the notification sent to the device from the GW URL in answer to the inquiry request. Displayed only when the result is registered at the GW URL.		

206	Register Execute	CTL	[- / - / -] [Execute]
	Executes "Embedded RCG Registration".		
207	Register Result	CTL	[0 to 255 / 0 / 1/step]
	<p>Displays a number that indicates the registration result.</p> <p>0: Succeeded</p> <p>1: Inquiry number error</p> <p>2: Registration in progress</p> <p>3: Proxy error (proxy enabled)</p> <p>4: Proxy error (proxy disabled)</p> <p>5: Proxy error (Illegal user name or password)</p> <p>8: Other error</p> <p>9: Registration executing</p>		
208	Error Code	CTL	[-2147483647 to 2147483647 / - / - / step]
	Displays a number that describes the error code that was issued when either SP5816-204 or SP5816-207 was executed.		
	Cause	Code	Meaning
	Illegal Modem Parameter	-11001	Chat parameter error
		-11002	Chat execution error
-11003		Unexpected error	

Operation Error, Incorrect Setting	-12002	Inquiry, registration attempted without acquiring device status.
	-12003	Attempted registration without execution of an inquiry and no previous registration.
	-12004	Attempted setting with illegal entries for certification and ID2.
	-12005	@Remote communication is prohibited. The device has an Embedded RC gate-related problem.
	-12006	A confirmation request was made after the confirmation had been already completed.
	-12007	The request number used at registration was different from the one used at confirmation.
	-12008	Update certification failed because mainframe was in use.
	-12009	D2 mismatch between an individual certification and NVRAM.
	-12010	Certification area is not initialized.

	Error Caused by Response from GW URL	-2385	Attempted dial up overseas without the correct international prefix for the telephone number.
		-2387	Not supported at the Service Center
		-2389	Database out of service
		-2390	Program out of service
		-2391	Two registrations for same device
		-2392	Parameter error
		-2393	Basil not managed
		-2394	Device not managed
		-2395	Box ID for Basil is illegal
		-2396	Device ID for Basil is illegal
		-2397	Incorrect ID2 format
		-2398	Incorrect request number format
209	Install Clear	CTL	[- / - / -] [Execute]
	Releases the machine from its embedded RCG setup.		
250	CommLog Print	CTL	[- / - / -]
	Prints the communication log.  Note <ul style="list-style-type: none"> This SP is activated only when SP 5816-021 is set to "1". 		
5821	[Remote Service Address] (D158/159)		
002	RCG IP Address	*CTL	[00000000h to FFFFFFFFh / 00000000h / 1/step]
	Sets the IP address of the RCG (Remote Communication Gate) destination for call processing at the remote service center.		

003	RCG Port Number	*CTL	[0 to 65535/ 443 / 1/step]
	Sets the port number of the RCG (Remote Communication Gate) destination for call processing at the remote service center.		
004	RCG URL Path	*CTL	[0 to 16 characters (half characters) Default /RCG/services/ -]

5824	[NV-RAM Data Upload] (D158/159)		
	Uploads the NVRAM data to an SD card. Push Execute.		
001	NV-RAM Data Upload	CTL	[- / - / -] [Execute]

5825	[NV-RAM Data Download] (D158/159)		
	Downloads data from an SD card to the NVRAM in the machine. After downloading is completed, remove the card and turn the machine power off and on.		
001	NV-RAM Data Download	CTL	[- / - / -] [Execute]

5827	[Program Download] (D160/D161/D170)		
	Copies the software program from the IC card to the flash ROM. To execute this SP, (1) turn off the main power switch, (2) insert the IC card, (3) press the power key and hold it down, and (4) turn on the main power switch (while you keep holding the power key). The copier reads the software program from the IC card if you turn on the copier like this. The SP mode is automatically activated.		
001	Program Download	CTL	[- / - / -] 0: Disabled, 1: Enabled

5828	[Network Setting] (D158/159)		
065	Job Spooling	*CTL	[0 or 1 / 0 / 1/step] 0: Disabled, 1: Enabled
	Enables/disables Job Spooling.		

066	Job Spooling Clear: Start Time	*CTL	[0 or 1 / 1 / 1/step] 0: Data is cleared) 1: Automatically printed
Treatment of the job when a spooled job exists at power on.			
069	Job Spooling (Protocol)	*CTL	[- / 0x7f : All Active / -] 0: Off 1: Off bit0: LPR bit1: FTP bit2: IPP bit3: SMB bit4: BMLinkS bit5: DIPRINT bit6: sftp bit7: wsprnd
This SP determines whether job spooling is enabled or disabled for each protocol. This is an 8-bit setting.			
087	Protocol usage	*CTL	[0 or 1 / 0x00000000 / 1 bit/step] Shows which protocols have been used with the network. 0: Off (Not used the network with the protocol.) 1: On (Used the network with the protocol once or more.) bit0: IPsec, bit1: IPv6, bit2: IEEE 802. 1X, bit3: Wireless LAN, bit4: Security mode level setting, bit5: Appletalk, bit6: DHCP, bit7: DHCPv6, bit8: telnet, bit9: SSL, bit10: HTTPS, bit11: BMLinkS printing, bit12: diprint printing, bit13: LPR printing, bit14: ftp printing, bit15: rsh printing, bit16: SMB printing, bit17: WSD-Printer, bit18: WSD-Scanner, bit19: Scan to SMB, bit20: Scan to NCP, bit21: Reserve, bit22: Bluetooth, bit23: IEEE 1284, bit24: USB printing, bit25: Dynamic DNS, bit26: Netware printing, bit27: LLTD, bit28: IPP printing, bit29: IPP printing (SSL), bit30: ssh, bit31: sftp

090	TELNET (0: OFF 1: ON)	*CTL	[0 or 1 / 1 / 1/step] 0: Disable, 1: Enable
Enables or disables the Telnet protocol.			
091	Web (0: OFF 1: ON)	*CTL	[0 or 1 / 1 / 1/step] 0: Disable, 1: Enable
Enables or disables the Web operation.			
145	Active IPv6 Link Local Address	CTL	[00000000000000000000000000000000 0000h to FFFFFFFFFFFFFFFFFFFFFFFFFFFFFFFF80h / 00000000000000000000000000000004 0h / -]
This is the IPv6 local address link referenced on the Ethernet or wireless LAN (802.11b) in the format: "Link Local Address" + "Prefix Length" The IPv6 address consists of a total 128 bits configured in 8 blocks of 16 bits each.			
147	SettingActive IPv6 Stateless Address 1	CTL	[00000000000000000000000000000000 0000h to
149	SettingActive IPv6 Stateless Address 2	CTL	FFFFFFFFFFFFFFFFFFFFFFFFFFFFFFFF80h / 00000000000000000000000000000004 0h / -]
151	SettingActive IPv6 Stateless Address 3	CTL	These SPs are the IPv6 status addresses (1 to 5) referenced on the Ethernet or wireless LAN
153	SettingActive IPv6 Stateless Address 4	CTL	(802.11b) in the format: "Status Address" + "Prefix Length"
155	SettingActive IPv6 Stateless Address 5	CTL	The IPv6 address consists of a total 128 bits configured in 8 blocks of 16 bits each.

156	IPv6 Manual Address	*CTL	[00000000000000000000000000000000 0000h to FFFFFFFFFFFFFFFFFFFFFFFFFFFF80h / 00000000000000000000000000000004 0h / -]
	<p>This SP is the IPv6 manually set address referenced on the Ethernet or wireless LAN (802.11b) in the format: "Manual Set Address" + "Prefix Length" The IPv6 address consists of a total 128 bits configured in 8 blocks of 16 bits each.</p>		
158	IPv6 Gateway Address	*CTL	[00000000000000000000000000000000 h to FFFFFFFFFFFFFFFFFFFFFFFFFFh/ 0000000000000000000000000000000h / -]
	<p>This SP is the IPv6 gateway address referenced on the Ethernet or wireless LAN (802.11b). The IPv6 address consists of a total 128 bits configured in 8 blocks of 16 bits each.</p>		
161	IPv6 Stateless Auto Setting	*CTL	[0 or 1 / 1 / 1/step] 0: Disable, 1: Enable
	<p>Enables or disables the automatic setting for IPv6 stateless.</p>		
236	Web Item visible	*CTL	[0x0000 to 0xffff / 0xffff / -] 0: Not displayed, 1:Displayed bit0: Net RICOH bit1: Consumable Supplier bit2-15: Reserved (all)
	<p>Displays or does not display the Web system items.</p>		
237	Web shopping link visible	*CTL	[0 or 1 / 1 / 1/step] 0: Not display, 1:Display
	<p>Displays or does not display the link to Net RICOH on the top page and link page of the web system.</p>		
238	Web supplies Link visible	*CTL	[Up to 31 char / URL1 / 1/step] 0: Not display, 1:Display
	<p>Displays or does not display the link to Consumable Supplier on the top page and link page of the web system.</p>		

239	Web Link1 Name	*CTL	[Up to 31char / URL1 / 1/step]
	This SP confirms or changes the URL1 name on the link page of the web system. The maximum characters for the URL name are 31 characters.		
240	Web Link1 URL	*CTL	[Up to 127char / URL1 / 1/step]
	This SP confirms or changes the link to URL1 on the link page of the web system. The maximum characters for the URL are 127 characters.		
241	Web Link1 visible	*CTL	[0 or 1 / 1 / 1] 0: Not display, 1:Display
	Displays or does not display the link to URL1 on the top page of the web system.		
242	Web Link2 Name	*CTL	Same as "-239"
243	Web Link2 URL	*CTL	Same as "-240"
244	Web Link2 visible	*CTL	Same as "-241"
249	DHCPv6 DUID	*CTL	[- / - / -]

5832	[HDD Formatting] (D158/159)		
	Initializes the hard disk. Use this SP mode only if there is a hard disk error.		

001	HDD Formatting (ALL)	CTL	[- / - / -] [Execute]
002	HDD Formatting (IMH)	CTL	
003	HDD Formatting (Thumbnail)	CTL	
004	HDD Formatting (Job Log)	CTL	
005	HDD Formatting (Printer Fonts)	CTL	
006	HDD Formatting (User Info 1)	CTL	
007	HDD Formatting (User Info 2)	CTL	
008	HDD Formatting (Scanner Mail)	CTL	
009	HDD Formatting (Data for a Design)	CTL	
010	HDD Formatting (Log)	CTL	
011	HDD Formatting (Ridoc I/F)	CTL	

5836	[Capture Settings] (D158/159)		
001	Capture Function (0:Off 1:On)	*CTL	[0 or 1 / 0 / 1] 0: Disable, 1: Enable
	With this function disabled, the settings related to the capture feature cannot be initialized, displayed, or selected.		
002	Panel Setting	*CTL	[0 or 1 / 0 / 1] 0: Displayed, 1: Not displayed
	Displays or does not display the capture function buttons.		
072	Reduction for Copy B&W Text	*CTL	[0 to 3, 6 / 0 / 1/step]
073	Reduction for Copy B&W Other	*CTL	0: 1to-1 1: 1/2 2: 1/3 3: 1/4 6: 2/3

075	Reduction for Printer B&W	*CTL	[0 to 3, 6 / 0 / 1/step] 0: 1to-1 1: 1/2 2: 1/3 3: 1/4 6: 2/3
082	Format for Copy B&W Text	*CTL	[0 to 3 / 1 / 1/step] 0: JFIF/JPEG, 1: TIFF/MMR, 2: TIFF/MH, 3: TIFF/MR
083	Format for Copy B&W Other	*CTL	[0 to 3 / 1 / 1/step] 0: JFIF/JPEG, 1: TIFF/MMR, 2: TIFF/MH, 3: TIFF/MR
085	Format for Printer B&W	*CTL	[0 to 3 / 1 / 1/step] 0: JFIF/JPEG, 1: TIFF/MMR, 2: TIFF/MH, 3: TIFF/MR
091	Default for JPEG	*CTL	[5 to 95 / 50 / 1/step]
	Sets the JPEG format default for documents sent to the document management server via the MLB with JPEG selected as the format. Enabled only when optional MLB (Media Link Board) is installed.		
101	Primary srv IP address	*CTL	[000.000.000.000 to 255.255.255.255 / - / 1/step]
	Sets the IP address for the primary capture server. This is basically adjusted by the remote system.		
102	Primary srv scheme	*CTL	[0 to 6 char / NULL / -/step]
	This is basically adjusted by the remote system.		
103	Primary srv port number	*CTL	[1 to 65535 / 80 / 1/step]
	This is basically adjusted by the remote system.		
104	Primary srv URL path	*CTL	[0 to 16 char / - / 1/step]
	This is basically adjusted by the remote system.		

111	Secondary srv IP address	*CTL	[000.000.000.000 to 255.255.255.255 / - / 1/step]
	Sets the IP address for the secondary capture server. This is basically adjusted by the remote system.		
112	Secondary srv scheme	*CTL	[0 to 6 char / NULL / -/step]
	This is basically adjusted by the remote system.		
113	Secondary srv port number	*CTL	[1 to 65535 / 80 / 1/step]
	This is basically adjusted by the remote system.		
114	Secondary srv URL path	*CTL	[0 to 16 char / - / 1/step]
	This is basically adjusted by the remote system.		
120	Default Reso Rate Switch	*CTL	[0 or 1 / 0 / 1/step]
	This is basically adjusted by the remote system.		
122	Reso: Copy(Mono)	*CTL	[0 to 255 / 3 / 1/step]
	Selects the resolution for BW copy mode. This is basically adjusted by the remote system. 0: 600dpi/ 1: 400dpi/ 2: 300dpi/ 3: 200dpi/ 4: 150dpi/ 5: 100dpi/ 6: 75dpi		
124	Reso: Print(Mono)	*CTL	[0 to 255 / 3 / 1/step]
	Selects the resolution for BW print mode. This is basically adjusted by the remote system. 0: 600dpi/ 1: 400dpi/ 2: 300dpi/ 3: 200dpi/ 4: 150dpi/ 5: 100dpi/ 6: 75dpi		
125	Reso: Fax(Color)	*CTL	[0 to 255 / 4 / 1/step]
	Selects the resolution for color fax mode. This is basically adjusted by the remote system. 0: 600dpi/ 1: 400dpi/ 2: 300dpi/ 3: 200dpi/ 4: 150dpi/ 5: 100dpi/ 6: 75dpi		
126	Reso: Fax(Mono)	*CTL	[0 to 255 / 3 / 1/step]
	Selects the resolution for BW fax mode. This is basically adjusted by the remote system. 0: 600dpi/ 1: 400dpi/ 2: 300dpi/ 3: 200dpi/ 4: 150dpi/ 5: 100dpi/ 6: 75dpi		

127	Reso: Scanner(Color)	*CTL	[0 to 255 / 4 / 1/step]
	Selects the resolution for color scanning mode. This is basically adjusted by the remote system. 0: 600dpi/ 1: 400dpi/ 2: 300dpi/ 3: 200dpi/ 4: 150dpi/ 5: 100dpi/ 6: 75dpi		
128	Reso: Scanner(Mono)	*CTL	[0 to 255 / 3 / 1/step]
	Selects the resolution for BW scanning mode. This is basically adjusted by the remote system. 0: 600dpi/ 1: 400dpi/ 2: 300dpi/ 3: 200dpi/ 4: 150dpi/ 5: 100dpi/ 6: 75dpi		
141	All Addr Info Switch	*CTL	[0 or 1 / 1 / 1/step]
142	Stand-by Doc Max Number	*CTL	[10 to 10000 / 2000 / 1/step]

5840	[IEEE 802.11] (D158/159)		
006	Channel Max	*CTL	[1 to 14 / 11 (NA), 13 (EU), 14 (JPN) / 1/step] Range JPN: 1 to 14 NA: 1 to 11 EU: 1 to 13
	Sets the maximum number of channels available for data transmission via the wireless LAN. The number of channels available varies according to location. The default settings are set for the maximum end of the range for each area. Adjust the upper 4 bits to set the maximum number of channels.		
<div style="border: 1px solid blue; border-radius: 10px; padding: 2px; display: inline-block;">  Note </div> <ul style="list-style-type: none"> • Do not change the setting. 			

007	Channel Min	*CTL	[1 to 14 / 1 / 1/step] Range JPN: 1 to 14 NA: 1 to 11 EU: 1 to 13
Sets the minimum number of channels available for data transmission via the wireless LAN. The number of channels available varies according to location. The default settings are set for the minimum end of the range for each area. Adjust the lower 4 bits to set the minimum number of channels. <p>Note</p> <ul style="list-style-type: none"> Do not change the setting. 			
008	Transmission Speed	*CTL	[0x00 to 0xFF / 0xFF to Auto / -] 0 x FF to Auto [Default] 0 x 11 - 55M Fix 0 x 10 - 48M Fix 0 x 0F - 36M Fix 0 x 0F - 24M Fix 0 x 0E - 18M Fix 0 x 0D - 12M Fix 0 x 0B - 9M Fix 0 x 0A - 6M Fix 0 x 07 - 11M Fix 0 x 06 - 5.5M Fix 0 x 05 - 2M Fix 0 x 08 - 1M Fix 0 x 13 - 0 x FE (reserved) 0 x 12 - 72M (reserved) 0 x 09 - 22M (reserved)

011	WEP key Select	*CTL	[00 to 11 / 00 / 1/step] 00: Key #1 01: Key #2 (Reserved) 10: Key #3 (Reserved) 11: Key #4 (Reserved)
	Selects the WEP key.		
013	RTS/CTS Thresh	*CTL	[0 to 3000 / 2432 / 1/step]
	Adjusts the RTS/CTS threshold for the IEEE802.11 card. This SP is displayed only when the IEEE802.11 card is installed.		
042	Fragment Thresh	*CTL	[256 to 2346 / 2346 / 1/step]
	Adjusts the fragment threshold for the IEEE802.11 card. This SP is displayed only when the IEEE802.11 card is installed.		
043	11g CTS to Self	*CTL	[0 or 1 / 1 / 1/step] 0: OFF, 1: ON
	Determines whether the CTS self function is turned on or off. This SP is displayed only when the IEEE802.11 card is installed.		
044	11g Slot Time	*CTL	[0 or 1 / 0 / 1/step] 0: 20 um, 1: 9 um
	Selects the slot time for IEEE802.11.		
045	WPA Debug Lvl	*CTL	[1 to 3 / 3 / 1/step] 1: Info, 2: warning, 3: error
	Selects the debug level for WPA authentication application. This SP is displayed only when the IEEE802.11 card is installed.		
5841	[Supply Name Setting] (D158/159)		

001	Toner Name Setting:Black	*CTL	Specifies supply names. These appear on the screen when the user presses the Inquiry button in the user tools screen. [0 to 20 / NULL / 1 byte/step]
002	Toner Name Setting:Cyan	*CTL	
003	Toner Name Setting:Yellow	*CTL	
004	Toner Name Setting:Magenta	*CTL	
007	OrgStamp	*CTL	
011	Staple Std1	*CTL	
012	Staple Std2	*CTL	
013	Staple Std3	*CTL	
014	Staple Std4	*CTL	
021	Staple Bind 1	*CTL	
022	Staple Bind 2	*CTL	
023	Staple Bind 3	*CTL	

5842	[GWWS Analysis] (D158/159)		
001	Setting 1	*CTL	[8bit assign / 00000000 / bit switch] 0bit[LSB]: system, other group 1bit: capture related group 2bit: authentication related group 3bit: address book related group 4bit: device management related group 5bit: output related(print, FAX, and delivery) group 6bit: repository, FO,etc. document related group 7bit: debug log level suppression
Default: 00000000 – do not change Netfiles: Jobs to be printed from the document server using a PC and the DeskTopBinder software			

002	Setting 2	*CTL	[8bit assign / 00000000 / bit switch] 0~6bit: unused 7bit: time stamp setting for 5682mmesg log. (1: min./sec/msec, 0: day/hour/min./sec)
Optional settings for debug output mode for each NFA process.			

5844	[USB] (D158/159)		
001	Transfer Rate	*CTL	[0x01 or 0x04 / 0x04 / -] 0x01: Full speed (fixed) 0x04: H-speed, F-speed (auto change)
002	Vendor ID DFU	*CTL	[0x0000 to 0xFFFF / 0x05CA / 1/step]
Displays the vendor ID.			
003	Product ID DFU	*CTL	[0x0000 to 0xFFFF / 0x0403 / 1/step]
Displays the product ID.			
004	Device Release Number DFU	*CTL	[0 to 9999 / 100 / 1/step]
Displays the development release version number.			
005	Fixed USB Port	*CTL	[0x00 to 0x02 / 0x00 / 1/step]
	0x00: Disable 0x01: Enable (Level 1) Device driver reinstallation is not required in the same machine. 0x02: Enable (Level 2) Device driver reinstallation is not required in any machine.		
006	PnP Model Name	*CTL	[20digits character / " Laser Printer " / -]
Displays PnP Model Name.			
007	PnP Serial Number	*CTL	[12digits character / NULL / -]
Displays PnP Serial No.			

008	Mac Supply Level	*CTL	[0 or 1 / 1 / 1/step] 0: Disable, 1: Enable
100	Notify Unsupport	*CTL	[0x00 or 0x01 / 0x01 / 1/step] 0x00: Function disabled 0x01: Function enabled

5845	[Delivery Server Setting] (D158/159)		
	Provides items for delivery server settings.		
001	FTP Port No.	*CTL	[1 to 65535 / 3670 / 1/step]
	Sets the FTP port number used when image files to the Scan Router Server.		
002	IP Address (Primary)	*CTL	[000.000.000.000 to 255.255.255.255 / - / 1/step]
	Use this SP to set the Scan Router Server address. The IP address under the transfer tab can be referenced by the initial system setting.		
006	Delivery Error Display Time	*CTL	[0 to 999 / 300 / 1sec/step]
	Use this setting to determine the length of time the prompt message is displayed when a test error occurs during document transfer with the NetFile application and an external device.		
008	IP Address (Secondary)	*CTL	[000.000.000.000 to 255.255.255.255 / 000.000.000.000 / 1/step]
	Specifies the IP address assigned to the computer designated to function as the secondary delivery server of Scan Router. This SP allows only the setting of the IP address without reference to the DNS setting.		
009	Delivery Server Model	*CTL	[0 to 4/ 0 / 1/step] 0: Unknown 1: SG1 Provided 2: SG1 Package 3: SG2 Provided 4: SG2 Package
			Allows changing the model of the delivery server registered by the I/O device.

010	Delivery Svr. Capability	*CTL	[0 to 255 / 0 / 1 /step]
	<p>Changes the capability of the registered that the I/O device registered.</p> <p>Bit7 = 1 Comment information exists</p> <p>Bit6 = 1 Direct specification of mail address possible</p> <p>Bit5 = 1 Mail RX confirmation setting possible</p> <p>Bit4 = 1 Address book automatic update function exists</p> <p>Bit3 = 1 Fax RX delivery function exists</p> <p>Bit2 = 1 Sender password function exists</p> <p>Bit1 = 1 Function to link MK-1 user and Sender exists</p> <p>Bit0 = 1 Sender specification required (if set to 1, Bit6 is set to "0")</p>		
011	Delivery Svr Capability (Ext)	*CTL	[0 to 255 / - / x2/step]
	<p>Changes the capability of the registered that the I/O device registered.</p> <p>Because SP5845-010 is full, set aside an area for future additional capabilities.</p> <p>Bit7 = 1: Not used</p> <p>Bit6 = 1: Not used</p> <p>Bit5 = 1: Not used</p> <p>Bit4 = 1: Not used</p> <p>Bit3 = 1: Not used</p> <p>Bit2 = 1: Not used</p> <p>Bit1 = 1: Not used</p> <p>Bit0 = 1: Not used</p>		
013	Server Scheme (Primary) DFU	*CTL	[Up to 6 char / - / -/step]
	This SP is used for the scan router program.		
014	Server Port Number (Primary) DFU	*CTL	[1 to 65535 / 80 / 1/step]
	This SP is used for the scan router program.		
015	Server URL Path (Primary) DFU	*CTL	[Up to 16 byte / - / -/step]
	This SP is used for the scan router program.		

016	Server Scheme (Secondary) DFU	*CTL	[Up to 6 char / - / -/step]
	This SP is used for the scan router program.		
017	Server Port Number (Secondary) DFU	*CTL	[1 to 65535 / 80 / 1/step]
	This SP is used for the scan router program.		
018	Server URL Path (Secondary) DFU	*CTL	[Up to 16 byte / - / -/step]
	This SP is used for the scan router program.		
022	Rapid Sending Control	*CTL	[0 or 1 / 1 / -/step] 0: Control disabled 1: Control enabled
	Enables or disables the prevention function for the continuous data sending error.		

5846	[UCS Settings] (D158/159)		
001	Machine ID (for Delivery Server)	*CTL	[- / - / -]
	Displays the unique device ID in use by the delivery server directory. The value is only displayed and cannot be changed. This ID is created from the NIC MAC or IEEE 1394 EUI. The ID is displayed as either 6-byte or 8-byte binary.		
002	Machine ID Clear(for Delivery Server)	*CTL	[- / - / -] [Execute]
	Clears the unique ID of the device used as the name in the file transfer directory. Execute this SP if the connection of the device to the delivery server is unstable. After clearing the ID, the ID will be established again automatically by cycling the machine off and on.		
003	Maximum Entries	*CTL	[2000 to 20000 / 2000 / 1/step]
	Changes the maximum number of entries that UCS can handle. If a value smaller than the present value is set, the UCS managed data is cleared, and the data (excluding user code information) is displayed.		

006	Delivery Server Retry Timer	*CTL	[0 to 255 / 0 / 1/step]
	Sets the interval for retry attempts when the delivery server fails to acquire the delivery server address book.		
007	Delivery Server Retry Times	*CTL	[0 to 255 / 0 / 1/step]
	Sets the number of retry attempts when the delivery server fails to acquire the delivery server address book.		
008	Delivery Server Maximum Entries	*CTL	[2000 to 20000 / 2000 / 1/step]
	Sets the maximum number account entries of the delivery server user information managed by UCS.		
010	LDAP Search Timeout	*CTL	[1 to 255 / 60 / 1/step]
	Sets the length of the timeout for the search of the LDAP server.		
020	WSD Maximum Entries	*CTL	[5 to 250 / 250 / 1/step]
	Sets the maximum entries for the address book of the WSD (WS-scanner).		
021	Folder Auth Change	*CTL	[0 or 1 / 0 / 1/step] 0: Login User, 1: Destination
040	Addr Book Migration(USB->HDD)	*CTL	[- / - / -] [Execute]

041	Fill Addr Acl Info	*CTL	[- / - / -] [Execute]
<p>This SP must be executed immediately after installation of an HDD unit in a basic machine that previously had no HDD. The first time the machine is powered on with the new HDD installed, the system automatically takes the address book from the NVRAM and writes it onto the new HDD. However, the new address book on the HDD can be accessed only by the system administrator at this stage. Executing this SP by the service technician immediately after power on grants full address book access to all users.</p> <p>Procedure</p> <ol style="list-style-type: none"> 1. Turn the machine off. 2. Install the new HDD. 3. Turn the machine on. 4. The address book and its initial data are created on the HDD automatically. 5. However, at this point the address book can be accessed by only the system administrator or key operator. 6. Enter the SP mode and do SP5846-041. After this SP executes successfully, any user can access the address book. 			
043	Addr Book Media	*CTL	[0 to 30 / 0 / 1 / step] 0: Unconfirmed 1: SD Slot 1 2: SD Slot 2 3: SD Slot 3 4: USB Flash ROM 10: SD Slot 10 20: HDD 30: Nothing
Displays the slot number where an address book data is in.			
047	Initialize Local Address Book	CTL	[- / - / -] [Execute]
Clears the local address book information, including the user code.			

048	Initialize Delivery Addr Book	CTL	[- / - / -] [Execute]
	Clears the distribution address book information, except the user code.		
049	Initialize LDAP Addr Book	CTL	[- / - / -] [Execute]
	Clears the LDAP address book information, except the user code.		
050	Initialize All Addr Book	CTL	[- / - / -] [Execute]
	Clears all directory information managed by UCS, including all user codes.		
051	Backup All Addr Book	CTL	[- / - / -] [Execute]
	Uploads all directory information to the SD card.		
052	Restore All Addr Book	CTL	[- / - / -] [Execute]
	Downloads all directory information from the SD card.		
053	Clear Backup Info	CTL	[- / - / -] [Execute]
	<p>Deletes the address book data from the SD card in the service slot.</p> <p>Deletes only the files that were uploaded from this machine.</p> <p>This feature does not work if the card is write-protected.</p> <p> Note</p> <ul style="list-style-type: none"> After you do this SP, go out of the SP mode, and then turn the power off. Do not remove the SD card until the Power LED stops flashing. 		

060	Search Option	*CTL	[0x00 to 0xff / 0x0f / 1]
	<p>This SP uses bit switches to set up the fuzzy search options for the UCS local address book.</p> <p>Bit: Meaning</p> <p>0: Checks both upper/lower case characters</p> <p>1: Japan Only</p> <p>2: Japan Only</p> <p>3: Japan Only</p> <p>4 to 7: Not Used</p>		
062	Complexity Option 1	*CTL	[0 to 32 / 0 / 1/step]
	<p>Use this SP to set the conditions for password entry to access the local address book. Specifically, this SP limits the password entry to upper case and sets the length of the password.</p> <p> Note</p> <ul style="list-style-type: none"> This SP does not normally require adjustment. This SP is enabled only after the system administrator has set up a group password policy to control access to the address book. 		
063	Complexity Option 2 DFU	*CTL	[0 to 32 / 0 / 1/step]
	<p>Use this SP to set the conditions for password entry to access the local address book. Specifically, this SP limits the password entry to lower case and defines the length of the password.</p>		
064	Complexity Option 3 DFU	*CTL	[0 to 32 / 0 / 1/step]
	<p>Use this SP to set the conditions for password entry to access the local address book. Specifically, this SP limits the password entry to numbers and defines the length of the password.</p>		
065	Complexity Option 4 DFU	*CTL	[0 to 32 / 0 / 1/step]
	<p>Use this SP to set the conditions for password entry to access the local address book. Specifically, this SP limits the password entry to symbols and defines the length of the password.</p>		
091	FTP Auth Port Setting	*CTL	[0 to 65535 / 3671 / 1/step]
	<p>Specifies the FTP port for getting a distribution server address book that is used in the identification mode.</p>		

094	Encryption Stat	*CTL	[0 to 255 / - / 1/step]
	Shows the status of the encryption function for the address book data.		
5847	[Repository Resolution Reduction] (D158/159)		
	<p>SP5847-1 through SP5847-8 changes the default settings of image data transferred externally by the Net File page reference function.</p> <p>SP5847-21 sets the default for JPEG image quality of image files handled by NetFile. "Net files" are jobs to be printed from the document server using a PC and the DeskTopBinder software.</p> <p>Each section values are following:</p> <p>0: 1x 1: 1/2x 2: 1/3x 3: 1/4x 4: 1/6x 5: 1/8x 6: 2/3x</p>		
002	Rate for Copy B&W Text	*CTL	[0 to 6 / 0 / 1/step]
003	Rate for Copy B&W Other	*CTL	
005	Rate for Printer B&W	*CTL	[0 to 6 / 0 / 1/step]
021	Default Value of JPEG Quality	*CTL	[5 to 95 / 50 / 1/step]
	Sets the default value for the quality of JPEG images sent as NetFile pages. This function is available only with the MLB (Media Link Board) option installed.		
5848	[Web Service] (D158/159)		
	<p>SP5848-2 sets the 4-bit switch assignment for the access control setting. A setting of 0001 has no effect on access and delivery from Scan Router.</p> <p>5848 100 sets the maximum size allowed for downloaded images. The default is equal to 1 gigabyte.</p>		

002	Access Ctrl: Repository (only Lower 4 bits)	* CTL	[0000, 0001, or 0010 / 0010 / BitSwitch] 0000: access permission 0001: access restriction to DeskTop Binder. 0010: writing restriction
003	Access Contl: Doc.Box Print (only Lower 4 bits)	* CTL	Switches access control on and off. [0000 or 0001 / 0000 / Bit Switch/step] 0000: No access control 0001: Access control
004	Access Contl: uirectory (only Lower 4 bits)	* CTL	
007	Access Ctrl: Comm. Log Fax (Lower 4 bits)	* CTL	
009	Access Ctrl: Job Ctrl (Lower 4 bits)	* CTL	
011	Access Ctrl: Devicemanagement (Lower 4bits)	* CTL	
021	Access Ctrl: Delivery (Lower 4 bits)	* CTL	
022	Access Ctrl: uadministration (Lower 4bits)	* CTL	
099	Repository: Download Image Setting DFU	* CTL	
100	Repository: max size of Download Image	* CTL	[1 to 2048 / 2048 / 1/step]
	Specifies the max size of the image data that the machine can download.		
210	Setting: LogType: Job1	* CTL	Read only. [0 to 0xFFFFFFFF / 0 / 1/step]
211	Setting: LogType: Job2	* CTL	
212	Setting: LogType: Access	* CTL	

217	Setting: Timing	*CTL	Read only. [0 to 2 / 0 / 1/step]
-----	-----------------	------	-------------------------------------

5849	[Installation Date] (D158/159)		
001	Display	*CTL	[- / - / -]
	The "Counter Clear Day" has been changed to "Installation Date" or "Inst. Date".		
002	Switch to Print	*CTL	[0 or 1 / 1 / 1/step] 0: OFF (No Print) 1: ON (Print)
	Determines whether the installation date is printed on the printout for the total counter.		
003	Total Counter	*CTL	[0 to 99999999 / 0 / 1/step]

5851	[Bluetooth] (D158/159)		
001	Mode	*CTL	[0x00 or 0x01 / 0x00 / 1/step] 0x00:Public 0x01:Private
	Sets the operation mode for the Bluetooth Unit. Press either key.		

5853	[Stamp Date Download] (D158/159)		
	Push [Execute] to download the fixed stamp data from the machine ROM onto the hard disk. Then these stamps can be used by the system. If this is not done, the user will not have access to the fixed stamps ("Confidential", "Secret", etc.). You must always execute this SP after replacing the HDD or after formatting the HDD. Always switch the machine off and on after executing this SP.		
001	-	CTL	[- / - / -] [Execute]

5856	[Remote ROM Update] (D158/159)		
	Allows the technician to upgrade the firmware using a local port (IEEE1284) when updating the remote ROM.		

002	Local Port	CTL	[0 or 1 / 0 / 1/step] 0: Disable 1: Enable
5857	[Save Debug Log] (D158/159)		
001	On/Off (1:ON 0:OFF)	*CTL	[0 or 1 / 0 / 1/step] 0: OFF, 1: ON
	Switches the debug log feature on and off. The debug log cannot be captured until this feature is switched on.		
002	Target (2: HDD 3: SD)	*CTL	[2 or 3 / 2 / 1/step] 2: HDD, 3: SD Card
	Selects the storage device to save debug logs information when the conditions set with SP5-858 are satisfied.		
005	Save to HDD	*CTL	[-999999 to 999999 / 0 / 1/step]
	Specifies the decimal key number of the log to be written to the hard disk.		
006	Save to SD Card	*CTL	[-999999 to 999999 / 0 / 1/step]
	Saves the debug log of the input SC number in memory to the SD card.		
009	Copy HDD to SD Card(Latest 4MB)	*CTL	[- / - / -] [Execute]
	<p>Takes the most recent 4 MB of the log written to the hard disk and copies them to the SD Card.</p> <p>A unique file name is generated to avoid overwriting existing file names on the SD Card. Up to 4MB can be copied to an SD Card. 4 MB segments can be copied one by one to each SD Card.</p>		

010	Copy HDD to SD Card(Latest 4MB Any Key)	*CTL	[- / - / -] [Execute]
	<p>Takes the log of the specified key from the log on the hard disk and copies it to the SD Card.</p> <p>A unique file name is generated to avoid overwriting existing file names on the SD Card. Up to 4 MB can be copied to an SD Card. 4 MB segments can be copied one by one to each SD Card. This SP does not execute if there is no log on the HDD with no key specified.</p>		
011	Erase HDD Debug Data	*CTL	[- / - / -] [Execute]
	Erases all debug logs on the HDD		
012	Erase SD Card Debug Data	*CTL	[- / - / -] [Execute]
	<p>Erases all debug logs on the SD Card. If the card contains only debugging files generated by an event specified by SP5858, the files are erased when SP5857 010 or 011 is executed.</p> <p>To enable this SP, the machine must be cycled off and on.</p>		
013	Free Space on SD Card	*CTL	[- / - / -] [Execute]
	Displays the amount of space available on the SD card.		
014	Copy SD to SD(Latest 4MB)	*CTL	[- / - / -] [Execute]
	Copies the last 4MB of the log (written directly to the card from shared memory) onto an SD card.		
015	Copy SD to SD(Latest 4MB Any Key)	*CTL	[-999999 to 999999 / 0 / 1/step]
	This SP copies the log on an SD card (the file that contains the information written directly from shared memory) to a log specified by key number.		
016	Make HDD Debug	*CTL	[- / - / -] [Execute]
	This SP creates a 32 MB file to store a log on the HDD.		

017	Make SD Debug	*CTL	[- / - / -] [Execute]
	This SP creates a 4 MB file to store a log on an SD card.		
5858	[Debug Save When] (D158/159)		
	These SPs select the content of the debugging information to be saved to the destination selected by SP5857-002. SP5858-3 stores one SC specified by number. Refer to Section 4 for a list of SC error codes.		
001	Engine SC Error	*CTL	[0 or 1 / 0 / 1/step] 0: OFF, 1: ON
	Turns on/off the debug save for SC codes generated by printer engine errors.		
002	Controller SC Error	*CTL	[0 or 1 / 0 / 1/step] 0: OFF, 1: ON
	Turns on/off the debug save for SC codes generated by GW controller errors.		
003	Any SC Error	*CTL	[0 to 65535 / 0 / 1/step]
004	Jam	*CTL	[0 or 1 / 0 / 1/step] 0: OFF, 1: ON
	Turns on/off the debug save for jam errors.		
5859	[Debug Save Key No.] (D158/159)		
	These SPs allow you to set up to 10 keys for log files for functions that use common memory on the controller board.		

001	Key 1	*CTL	[-99999999 to 99999999 / 0 / 1/step]
002	Key 2	*CTL	
003	Key 3	*CTL	
004	Key 4	*CTL	
005	Key 5	*CTL	
006	Key 6	*CTL	
007	Key 7	*CTL	
008	Key 8	*CTL	
009	Key 9	*CTL	
010	Key 10	*CTL	

5860	[SMTP/POP3/IMAP4] (D158/159)		
	Partial Mail Receive Timeout	*CTL	[1 to 168 / 72 / 1hour/step]
020	Sets the amount of time to wait before saving a mail that breaks up during reception. The received mail is discarded if the remaining portion of the mail is not received during this prescribed time.		
	MDN Response RFC2298 Compliance	*CTL	[0 or 1 / 1 / 1/step] 0: No, 1: Yes
021	Determines whether RFC2298 compliance is switched on for MDN reply mail.		
	SMTP Auth. From Field Replacement	*CTL	[0 or 1 / 0 / 1/step] 0: No. "From" item not switched. 1: Yes. "From" item switched.
022	Determines whether the FROM item of the mail header is switched to the validated account after the SMTP server is validated.		

025	SMTP Auth. Direct Setting	*CTL	[0 to 255 / - / x2/step]
	Selects the authentication method for SMTP. Bit switch: <ul style="list-style-type: none"> • Bit 0: LOGIN • Bit 1: PLAIN • Bit 2: CRAM MD5 • Bit 3: DIGEST MD5 • Bit 4 to 7: Not used <div style="border: 1px solid blue; border-radius: 10px; padding: 2px; display: inline-block;"> Note </div> <ul style="list-style-type: none"> • This SP is activated only when SMTP authorization is enabled by UP mode. 		
026	S/MIME: MIME Header Setting	*CTL	[0 to 2 / 0 / 1/step] 0: Microsoft Outlook Express standard 1: Internet Draft standard 2: RFC standard
	Selects the MIME header type of an E-mail sent by S/MIME.		
028	S/MIME: Authentication Check	*CTL	[0 to 1 / 0 / 1/step] 0: No (not check), 1: Yes (check)
5869	[RAM Disk Setting] (D158/159)		
001	Mail Function	*CTL	[0 or 1 / 0 / 1/step] 0: Use, 1: Not use
	Set whether the RAM disk is used or not used when using the mail functions.		
5870	[Common keyInfo Writing] (D158/159)		
001	Writing	CTL	[- / - / -] [Execute]
	Writes to flash ROM the common proof for validating the device for @Remote specifications.		

003	Initialize	CTL	[- / - / -] [Execute]
	Initializes the data area of the common proof for validating.		
004	Writing:2048bit	CTL	[- / - / -] [Execute]

5873	[SDCardAppliMove] (D158/159)		
001	MoveExec	CTL	[- / - / -] [Execute]
	This SP copies the application programs from the original SD card in SD card slot 2 to an SD card in SD card slot 1.		
002	UndoExec	CTL	[- / - / -] [Execute]
	This SP copies back the application programs from an SD card in SD Card Slot 2 to the original SD card in SD card slot 1. Use this menu when you have mistakenly copied some programs by using "Move Exec" (SP5873-1).		

5875	[SC Auto Reboot] (D158/159)		
001	Reboot Setting	*CTL	[0 or 1 / 0 / 1/step]
	Enables or disables the automatic reboot function when an SC error occurs. 0: The machine reboots automatically when the machine issues an SC error and logs the SC error code. If the same SC occurs again, the machine does not reboot. 1: The machine does not reboot when an SC error occurs. The reboot is not executed for Type A or C SC codes.		
002	Reboot Type	*CTL	[0 or 1 / 0 / 1/step] 0: Manual reboot 1: Automatic reboot
	Selects the reboot method for SC.		

5878	[Option Setup] (D158/159)		
-------------	----------------------------------	--	--

001	Data Overwrite Security	CTL	[- / - / -] [Execute]
	Enables the Data Overwrite Security unit. Press "EXECUTE" on the operation panel. Then turn the machine off and on.		
002	HDD Encryption	*CTL	[- / - / -] [Execute]
	Installs the HDD Encryption unit.		

5885	[Set WIM Function] (D158/159) Web Image Monitor Settings		
	Close or disclose the functions of web image monitor.		
020	DocSvr Acc Ctrl	*CTL	[8bit assign / 00000000 / bit switch] 0: OFF, 1: ON Bit Meaning 0: Forbid all document server access (1) 1: Forbid user mode access (1) 2: Forbid print function (1) 3: Forbid fax TX (1) 4: Forbid scan sending (1) 5: Forbid downloading (1) 6: Forbid delete (1) 7: Forbid guest user
050	DocSvr Format	*CTL	[0 to 2 / 0 / 1/step] 0: Thumbnail, 1: Icon, 2: Details
	Selects the display type for the document box list.		
051	DocSvr Trans	*CTL	[5 to 20 / 10 / 1/step]
	Sets the number of documents to be displayed in the document box list.		

100	Set Signature	*CTL	[0 to 2 / 0 / 1/step] 0: Setting for each e-mail 1: Signature for all 2: No signature
	Selects whether the signature is added to the scanned documents with the WIM when they are transmitted by an e-mail.		
101	Set Encryption	*CTL	[0 or 1 / 0 / 1/step] 0: Not encrypted, 1:Encryption
	Determines whether the scanned documents with the WIM are encrypted when they are transmitted by an e-mail.		

5887	[SD GetCounter] (D158/159)		
001	SD GetCounter	CTL	[- / - / -] [Execute]
	<p>This SP sends a text file to an SD card inserted in SD card Slot 2 (lower slot). The operation stores.</p> <p>The file is stored in a folder created in the root directory of the SD card called SD_COUNTER.</p> <p>The file is saved as a text file (*.txt) prefixed with the number of the machine.</p> <ol style="list-style-type: none"> 1. Insert the SD card in SD card Slot 2 (lower slot). 2. Select SP5887 then touch [EXECUTE]. <p>Touch [Execute] in the message when you are prompted.</p> <p>Note</p> <ul style="list-style-type: none"> • "SD_COUNTER" folder must be created under the root directory of the SC card before this SP is executed. 		

5888	[Personal Information Protect] (D158/159)		
001	Personal Information Protect	*CTL	[0 or 1 / 0 / 1/step]
	<p>Selects the protection level for logs.</p> <p>0: No authentication, No protection for logs 1: No authentication, Protected logs (only an administrator can see the logs)</p>		

3

5893	[SDK Application Counter] (D158/159)		
	Displays the counter name of each SDK application.		
001	SDK-1	CTL	[- / - / -]
002	SDK-2	CTL	
003	SDK-3	CTL	
004	SDK-4	CTL	
005	SDK-5	CTL	
006	SDK-6	CTL	

5894	[External Counter Setting] (D158/159)		
001	Switch Charge Mode	*ENG	[0 to 2 / 0 / 1/step]

5-900 added
RTB 1b

5901	[Printer Free Run] (D160/D161/D170)		
	Executes the free run. Press "ON" to start; press "OFF" to stop.		
001	Printer Free Run	ENG	[0 or 1 / 0 / 1 / step]

5902	[Test Pattern] (D160/D161/D170)		
	<p>Note</p> <ul style="list-style-type: none"> Do not operate the machine until the test pattern is printed out completely. Otherwise, an SC occurs. <ol style="list-style-type: none"> Enter the SP mode and select SP5-902-001. Enter the number for the test pattern that you want to print and press [#]. When you are prompted to confirm your selection, touch "Yes" to select the test pattern for printing. Touch "Copy Window" to open the copy window, then select the settings for the test print (paper size etc.). Press the "Start" key to start the test print. After checking the test pattern, touch "SP Mode" on the LCD to return to the SP mode display. Reset SP5-902-001 to "0". Touch "Exit" twice to exit SP mode. 		
001	Test Pattern	*ENG	[0 to 255 / 0 / 1 / step]
No.	Pattern	No.	Pattern
0	None	11	Independent Pattern (1 dot)
1	Vertical Line (1 dot)	12	Independent Pattern (2dot)
2	Vertical Line (2dot)	13	Independent Pattern (4dot)
3	Horizontal Line (1 dot)	14	Trimming Area
4	Horizontal Line (2dot)	15	Black Band (Horizontal)
5	Grid Vertical Line	16	Black Band (Vertical)
6	Grid Horizontal Line	17	Checker Flag Pattern
7	Grid Pattern Small	18	Grayscale (Vertical)
8	Grid Pattern Large	19	Grayscale (Horizontal)
9	Argyle Pattern Small	20	Full Dot Pattern
10	Argyle Pattern Large	21	All White Pattern
5907	[Plug & Play Maker/Model Name] (D158/159)		

	Plug & Play Maker/Model/ Name	*CTL	See detail below
001	<p>Selects the brand name and the production name for Windows Plug & Play. This information is stored in the NVRAM. If the NVRAM is defective, these names should be registered again.</p> <p>After selecting, press the "Original Type" key and "#" key at the same time. When the setting is completed, the beeper sounds five times.</p>		

	[Plug & Play] (D160/D161/D170)		
5907	<p>Selects the brand name and production name for the Plug and Play function. These names are stored in the NVRAM. When the NVRAM data is corrupted, select these names once again. Use the right-arrow or left-arrow key to scroll through the list of brand names. To select a brand name, press the OK key. An asterisk (*) indicates which manufacture is currently selected.</p>		
001	Plug & Play	*ENG	[0 to 19 / 0 / 0 / step]

5908	[LCT Paper Size] (D158/159)		
001	0: A4 1: LT	*CTL	[0 or 1 / 1 / 1 / step]
	Specifies the paper size in the LCT.		

5913	[Switchover Permission Time] (D158/159)		
002	Print Application Timer	*CTL	[3 to 30 / 3 / 1sec/step]
	Sets the amount of time to elapse while the machine is in standby mode (and the operation panel keys have not been used) before another application can gain control of the display.		

5919	[State Of Encryption] (D158/159)		
001	State Of Encryption	*CTL	[0 or 1 / 0 / 1/step] 0: OFF (Not working) 1: ON (Working)

5967	[Copy Server Set Function] (D158/159)		
------	--	--	--

001	(0:ON 1:OFF)	*CTL	[0 or 1 / 0 / 1/step] 0: ON, 1: OFF
	Enables and disables the document server. This is a security measure that prevents image data from being left in the temporary area of the HDD. After changing this setting, you must switch the main switch off and on to enable the new setting.		
5973	[User Stamp Registration] (D158/159)		
	-		
101	Frame deletion setting	*CTL	[0 to 3 / 0 / 1mm/step]
5974	[Cherry Server] (D158/159)		
	Specifies which version of ScanRouter, "Light" or "Full", is installed.		
001	(0:Light 1:Full)	*CTL	[0 or 1 / 0 / 1/step] 0:Light 1:Full
5985	[Device Setting] (D158/159)		
	Enables/disables the on-board device.		
001	On Board NIC	CTL	[0 to 2 / 0 / 1/step] 0: Disable, 1: Enable, 2: Function limitation
	When the "Function limitation" is set, "On board NIC" is limited only for the NRS or LDAP/NT authentication. Note <ul style="list-style-type: none"> Other network applications than NRS or LDAP/NT authentication are not available when this SP is set to "2".Even though you can change the initial settings of those network applications, the settings do not work. 		
002	On Board USB	CTL	[0 or 1 / 0 / 1/step] 0: Disable, 1: Enable

5987	[Mech. Counter]		
	This SP detects that a mechanical counter device is removed. If it is detected, SC610 occurs.		
001	0: OFF.; 1: ON:	*ENG	[0 or 1 / 0 / 1/step]

3

5990	[SP Print Mode] (D158/159)		
	[SMC Print] (D160/D161/D170)		
Prints out the SMC sheets.			
001	All(Data List) (All)	CTL	Press "Execute" key to start printing the SMC sheets. [- / - / -] [Execute]
002	SP(Mode Data List) (SP)	CTL	
003	User Program	CTL	
004	Logging Data	CTL	
005	Diagnostic Report (Big Font)	CTL	
006	Non-Default (D158/159)	CTL	
007	NIB Summary (D158/159)	CTL	
008	Capture Log (D158/159)	CTL	
021	Copier User Program (D158/159)	CTL	
022	Scanner SP (D158/159)	CTL	
023	Scanner User Program (D158/159)	CTL	
024	SDK/J Summary (D158/159)	CTL	
025	SDK/J Application Info (D158/159)	CTL	
026	Printer SP (D158/159)	CTL	

5992	[SP Text Mode] (D158/159)		
	Exports the SMC sheet data to the SD Card.		
001	All(Data List)	CTL	Press "Execute" key to start exporting the SMC data in the SP mode display. [- / - / -] [Execute]
002	SP(Mode Data List)	CTL	
003	User Program	CTL	
004	Logging Data	CTL	
005	Diagnostic Report	CTL	
006	Non-Default	CTL	
007	NIB Summary	CTL	
008	Capture Log	CTL	
021	Copier User Program	CTL	
022	Scanner SP	CTL	
023	Scanner User Program	CTL	
024	SDK/J Summary	CTL	
025	SDK/J Application Info	CTL	
026	Printer SP	CTL	

Main SP Tables-6

SP6-XXX (Peripherals)

3

6006	[ADF Adjustment] (D158/159)		
	Adjusts the side-to-side and leading edge registration for simplex and duplex original feeding in ARDF mode. SP6006-5 sets the maximum setting allowed for rear edge erase.		
001	Side-to-Side Regist: Front	*ENG	[-3.0 to 3.0 / 0.0 / 0.1 mm / step]
002	Side-to-Side Regist: Rear	*ENG	[-3.0 to 3.0 / 0.0 / 0.1 mm / step]
003	Leading Edge Registration	*ENG	[-5.0 to 5.0 / 0.0 / 0.1 mm / step]
005	Buckle: Duplex Front	*ENG	[-5.0 to 5.0 / 0.0 / 0.1 mm / step]
006	Buckle: Duplex Rear	*ENG	[-5.0 to 5.0 / 0.0 / 0.1 mm / step]
007	Rear Edge Erase	*ENG	[-10.0 to 10.0 / 0.0 / 0.1 mm / step]

6006	[ADF Adjustment] (D160/D161/D170)		
	-		
001	StoS Regist	*ENG	[-3.0 to 3.0 / 0.0 / 0.1 mm / step]
	Adjusts the side-to-side registration for the front side of the original, for ARDF mode.		
002	Leading Regist	*ENG	[-5.0 to 5.0 / 0.0 / 0.1 mm / step]
	Adjusts the leading edge registration for both front and rear.		
003	Rear Edge Erase	*ENG	[-5.0 to 5.0 / 0.0 / 0.1 mm / step]
	Adjusts the trailing edge erase margin for ARDF mode.		
005	Magnification	*ENG	[-5.0 to 5.0 / 0.0 / 0.1 % / step]
	Adjusts the sub-scan magnification for the ARDF.		
006	Buckle: Front	*ENG	[-5.0 to 5.0 / 0.0 / 0.1 mm / step]
007	Buckle: Rear	*ENG	[-5.0 to 5.0 / 0.0 / 0.1 mm / step]

6007	[ADF INPUT Check] (D158/159)		
	Displays ADF sensor information.		
001	Original Length 1 (B5 Detection Sensor)	ENG	[0 or 1 / 0 / 1 / step] 0: No paper detected 1: Paper Detected
002	Original Length 2 (A4 Detection Sensor)	ENG	[0 or 1 / 0 / 1 / step] 0: No paper detected 1: Paper Detected
003	Original Length3 (LG Detection Sensor)	ENG	[0 or 1 / 0 / 1 / step] 0: No paper detected 1: Paper Detected
004	Original Width 1	ENG	[0 or 1 / 0 / 1 / step] 0: No paper detected 1: Paper Detected
005	Original Width 2	ENG	[0 or 1 / 0 / 1 / step] 0: No paper detected 1: Paper Detected
006	Original Width 3	ENG	[0 or 1 / 0 / 1 / step] 0: No paper detected 1: Paper Detected
007	Original Width 4	ENG	[0 or 1 / 0 / 1 / step] 0: No paper detected 1: Paper Detected
008	Original Width 5	ENG	[0 or 1 / 0 / 1 / step] 0: No paper detected 1: Paper Detected
009	Original Detection	ENG	[0 or 1 / 0 / 1 / step] 0: No paper detected 1: Paper Detected

011	Skew Correction	ENG	[0 or 1 / 0 / 1 / step] 0: No paper detected 1: Paper Detected
013	Registration Sensor	ENG	[0 or 1 / 0 / 1 / step] 0: No paper detected 1: Paper Detected
014	Exit Sensor	ENG	[0 or 1 / 0 / 1 / step] 0: No paper detected 1: Paper Detected
015	Feed Cover Sensor	ENG	[0 or 1 / 0 / 1 / step] 0: Close 1: Open
016	Lift Up Sensor	ENG	[0 or 1 / 0 / 1 / step] 0: Not lifted 1: Lifted
023	Rear Edge Detection	ENG	[0 or 1 / 0 / 1 / step] 0: No paper detected 1: Paper Detected

6008	[ADF OUTPUT Check] (D158/159)		
	-		
003	Feed Motor Forward	ENG	[0 or 1 / 0 / 1 / step] 0:Off 1:On
	Rotates the paper feed motor to check the operation of ADF.		
004	Feed Motor Reverse	ENG	[0 or 1 / 0 / 1 / step] 0:Off 1:On
	Reverses the paper feed motor to check the operation of the load on the ADF.		

005	Relay Motor Forward	ENG	[0 or 1 / 0 / 1 / step] 0:Off 1:On
	Rotates the relay motor to check the operation of ADF.		
006	Relay Motor Reverse	ENG	[0 or 1 / 0 / 1 / step] 0:Off 1:On
	Reverse the relay motor to check the operation of ADF.		
011	Inverter Solenoid	ENG	[0 or 1 / 0 / 1 / step] 0:Off 1:On
	Drives the inverter Solenoid to check the operation of ADF.		
012	Stamp	ENG	[0 or 1 / 0 / 1 / step] 0:Off 1:On
	Drives the stamp to check the operation of ADF.		
013	Fan Motor	ENG	[0 or 1 / 0 / 1 / step] 0:Off 1:On
	Drives the fan motor to check the operation of ADF.		
014	Feed Clutch	ENG	[0 or 1 / 0 / 1 / step] 0:Off 1:On
	Drives the paper feed clutch to checks the operation of ADF.		
015	Feed Solenoid	ENG	[0 or 1 / 0 / 1 / step] 0:Off 1:On
	Drives the paper feed solenoid to check the operation of ADF.		

6009	[ADF Free Run] (D158/159)		
	-		
001	Free Run Simplex Motion	ENG	[- / - / -] [Execute]
	Executes an ARDF free run in simplex motion.		
002	Free Run Duplex Motion	ENG	[- / - / -] [Execute]
	Executes an ARDF free run in duplex motion.		
003	Free Run Stamp Motion	ENG	[- / - / -] [Execute]
	Executes an ARDF free run in stamp motion.		
004	Free Run Simplex Motion(low speed)	ENG	[- / - / -] [Execute]
	Executes an ARDF free run in simplex motion by low linear velocity.		
005	Free Run Simplex Motion(high speed)	ENG	[- / - / -] [Execute]
	Executes an ARDF free run in simplex motion by high linear velocity.		
006	Free Run Duplex Motion(low speed)	ENG	[- / - / -] [Execute]
	Executes an ARDF free run in duplex motion by low linear velocity.		
007	Free Run Simplex Motion(high speed)	ENG	[- / - / -] [Execute]
	Executes an ARDF free run in duplex motion by high linear velocity.		
6009	[ADF Free Run] (D160/161/D170)		
	Executes an ARDF free run in duplex motion.		
002	Duplex Motion	ENG	[- / - / -] [Execute]

6010	[Stamp Positon Adj.] (D158/159)		
	Adjusts the stamp position.		
001	-	*ENG	[-5.0 to 5.0 / 0.0 / 0.1 mm / step]

6016	[Original Size Detect Setting] (D158/159)		
	[ADF Size Detect] (D160/D161/D170)		
Specifies the original size for a size detected by the original sensor, since original sensors cannot recognize all sizes.			
001	-	*ENG	[0 to 255 / 0 / 1 / step]

6017	[DF Magnification Adj.] (D158/159)		
	-		
001	-	*ENG	[-5.0 to 5.0 / 0.0 / 0.1 % / step]

6020	[Skew Correction Moving Setting] (D158/159)		
	Sets whether or not to skew correction operation.		
001	-	*ENG	[0 or 1 / 0 / 1 / step]

6154	[INPUT Check] (D158/159)		
001	1 bin:Set Detection	ENG	[0 or 1 / 0 / 1 / step]
003	1BIN: Paper Remain	ENG	[0 or 1 / 0 / 1 / step]
004	1BIN: Cover Open	ENG	[0 or 1 / 0 / 1 / step]

6155	[OUTPUT Check] (D158/159)		
002	1BIN SOL	ENG	[0 or 1 / 1 / 1 / step]
	Drives the 1 bin solenoid to check the operation. Turns off automatically in 10 seconds after turned on.		

003	1BIN Motor: HOLD	ENG	[0 or 1 / 1 / 1 / step]
	Rotates the 1 bin motor to check the operation. Turns off automatically in 10 seconds after turned on.		
004	1BIN Motor: CW:High	ENG	[0 or 1 / 1 / 1 / step]
	Turns on after holding 50ms.		
005	1BIN Motor: CW:Low	ENG	[0 or 1 / 1 / 1 / step]
	Turns on after holding 50ms.		

6800	[Sheet Conversion (Thick Paper)] (D158/159)		
	Permits punching, including tab sheets.		
<div style="border: 1px solid blue; border-radius: 15px; padding: 2px; display: inline-block;"> Note </div> <ul style="list-style-type: none"> • Do not change this setting. 			
001	-	CTL	[1 to 3 / 3 / 1 / step] 1: 1 pages 2: 2 pages 3: 3 pages

6810	□ (D158/159)		
	-		
001	-	CTL	[1 to 3 / 3 / 1 / step] 1: 1 pages 2: 2 pages 3: 3 pages

6830	[Extra Staples] (D158/159)		
	<p>More than the standard number of sheets can be stapled. This SP sets the additional number of sheets (This Setting + Standard Number = maximum number of sheets).</p> <ul style="list-style-type: none"> • If the number of the maximum for staples is increased, and the mechanical warranty of the unit can be guaranteed, then the setting can take effect without changing the controller software. • However, assurance that mechanical performance can be guaranteed is required before changing the setting to increase the staple load for more than the maximum in the feed/exit specifications. Raising this setting without quality assurance could damage the machine. 		
001	Staple positions other than booklet stapling	*CTL	[0 to 50 / 0 / 1 / step]
002	2 Booklet stapling	*CTL	[0 to 50 / 0 / 1 / step]

6890	[Permits punching] (D158/159)		
001	-	CTL	[1 or 0 / 0 / 1 / step] 0: Disable, 1: Enable
	Permits punching, including tab sheets.		

RTB 1a
SP 6-900

Main SP Tables-7

SP7-XXX (Data Log)

3

7001	[Total Operation] (D160/D161/D170)		
	Displays the total operation time.		
001	SC Counter	*CTL	[0 to 9999999 / - / 1 min / step]

7401	[Total SC Counter] (D158/D159)		
	Displays the number of SC codes detected.		
001	SC Counter	*CTL	[0 to 65535 / - / 1 / step]
002	Total SC Counter	*CTL	[0 to 65535 / - / 1 / step]

7401	[Counter-SC Total] (D160/D161/D170)		
	Displays the number of SC codes detected.		
002	Counter-SC Total	*CTL	[0 to 9999 / - / 1 / step]

7403	[SC History]		
	<p>Logs and displays the SC codes detected.</p> <p>The 10 most recently detected SC Codes are displayed on the screen, and also can be seen on the SMC (logging) outputs.</p> <p>Note</p> <ul style="list-style-type: none"> If the same SC codes are detected continuously and total counter is not increasing, it only logs once in case of deleting other SC code logs. 		

001	Latest	* CTL	[- / - / -]
002	Latest 1	* CTL	
003	Latest 2	* CTL	
004	Latest 3	* CTL	
005	Latest 4	* CTL	
006	Latest 5	* CTL	
007	Latest 6	* CTL	
008	Latest 7	* CTL	
009	Latest 8	* CTL	
010	Latest 9	* CTL	

7404	[SC990 / SC991 History] (D158/D159)		
	<p>Logs and displays the SC990 / SC991 detected. The 10 most recently detected SC.</p> <p>Note</p> <ul style="list-style-type: none"> If the same SC codes are detected continuously and total counter is not increasing, it only logs once in case of deleting other SC code logs. 		
001	Latest	* CTL	[- / - / -]
002	Latest 1	* CTL	
003	Latest 2	* CTL	
004	Latest 3	* CTL	
005	Latest 4	* CTL	
006	Latest 5	* CTL	
007	Latest 6	* CTL	
008	Latest 7	* CTL	
009	Latest 8	* CTL	
010	Latest 9	* CTL	

7502	[Total Paper Jam] (D158/D159)		
	Displays the total number of jams detected.		
001	Jam Counter	*CTL	[00000 to 65535 / - / 1 sheet / step]
	If the JAM occurred in multiple places, it logs as one SC.		
002	Total Jam Counter	*CTL	[00000 to 65535 / - / 1 sheet / step]

7502	[Counter-Paper Jam] (D160/D161/D170)		
	Displays the total number of jams detected.		
001	Counter-Paper Jam	*CTL	[0000 to 9999 / - / 1 sheet / step]

7503	[Df Jam] (D158/D159)		
	Counts when Document Feeder Jam occurred.		
001	Total	*CTL	[00000 to 65535 / - / 1 sheet / step]
002	TotalSave	*CTL	[00000 to 65535 / - / 1 sheet/step]

7503	[Counter-Orgn Jam] (D160/D161/D170)		
	Counts when Document Feeder Jam occurred.		
001	Counter-Orgn Jam	*CTL	[0000 to 9999 / - / 1 sheet / step]

7504	[Paper Jam Loc] Paper Jam Location (D158/D159)		
	Displays the number of jams according to the location where jams were detected.		
001	At Power On	*CTL	Paper is not fed at power on. [0000 to 9999 / - / 1 / step]
003	Tray1: On	*CTL	[0000 to 9999 / - / 1 / step]
004	Tray2: On	*CTL	[0000 to 9999 / - / 1 / step]
005	Tray3: On	*CTL	[0000 to 9999 / - / 1 / step]
006	Tray4: On	*CTL	[0000 to 9999 / - / 1 / step]
008	Bypass: On	*CTL	[0000 to 9999 / - / 1 / step]

009	Duplex: On	*CTL	[0000 to 9999 / - / 1 / step]
018	PFU1: On	*CTL	[0000 to 9999 / - / 1 / step]
019	PFU2: On	*CTL	[0000 to 9999 / - / 1 / step]
020	PFU3: On	*CTL	[0000 to 9999 / - / 1 / step]
024	Fusing Entrance: On	*CTL	[0000 to 9999 / - / 1 / step]
032	Paper Exit On	*CTL	[0000 to 9999 / - / 1 / step]
038	Duplex On	*CTL	Paper stays on the duplex sensor. [0000 to 9999 / - / 1 / step]
087	Resistration: Off	*CTL	[0000 to 9999 / - / 1 / step]
096	Paper Exit: Off	*CTL	[0000 to 9999 / - / 1 / step]
102	Duplex Off	*CTL	Paper does not reach the duplex sensor. [0000 to 9999 / - / 1 / step]

7504	[Count-Each P Jam] (D160/D161/D170)		
	Displays the number of jams according to the location where jams were detected.		
001	At Power On	*CTL	Paper is not fed at power on. [000 to 999 / - / 1 / step]
010	Off-Regist NoFeed	*CTL	[000 to 999 / - / 1 / step]
	Paper does not reach the registration sensor (from a paper tray).		
011	Off-1 Vertical SN	*CTL	[000 to 999 / - / 1 / step]
	Paper does not reach the relay sensor.		
012	On-1 Vertical SN	*CTL	[000 to 999 / - / 1 / step]
	Paper is caught at the relay sensor.		
021	Off-2 Vertical SN	*CTL	[000 to 999 / - / 1 / step]
	Paper does not reach the vertical transport sensor.		
022	On-2 Vertical SN	*CTL	[000 to 999 / - / 1 / step]
	Paper is caught at the vertical transport sensor.		

031	Off-3 Vertical SN	*CTL	[000 to 999 / - / 1 / step]
032	On-3 Vertical SN	*CTL	[000 to 999 / - / 1 / step]
050	Off-Regist Bypass	*CTL	[000 to 999 / - / 1 / step]
	Paper does not reach the registration sensor (from the by-pass tray).		
060	Off-Regist Duplex	*CTL	[000 to 999 / - / 1 / step]
	Paper does not reach the registration sensor during reverse-side printing (for duplex printing).		
070	On-Regist SN	*CTL	[000 to 999 / - / 1 / step]
	Paper is caught at the registration sensor.		
120	On-Exit SN	*CTL	[000 to 999 / - / 1 / step]
	Paper is caught at the exit sensor (previous page).		
121	Off-Exit SN	*CTL	[000 to 999 / - / 1 / step]
	Paper does not reach the exit sensor.		
122	On-Exit SN	*CTL	[000 to 999 / - / 1 / step]
	Paper is caught at the exit sensor.		
123	Off-Dup Inverter	*CTL	[000 to 999 / - / 1 / step]
	Paper does not reach the duplex inverter sensor (from the registration roller).		
125	Off-Dup Inverter	*CTL	[000 to 999 / - / 1 / step]
	Paper is caught at the duplex inverter sensor.		
126	Off-Dup Entrance	*CTL	[000 to 999 / - / 1 / step]
127	On-Dup Entrance	*CTL	[000 to 999 / - / 1 / step]
128	Off-Duplex Exit	*CTL	[000 to 999 / - / 1 / step]
129	On-Duplex Exit	*CTL	[000 to 999 / - / 1 / step]
130	Off-1 Bin Exit	*CTL	[000 to 999 / - / 1 / step]
131	On-1 Bin Exit	*CTL	[000 to 999 / - / 1 / step]
210	Off-Buckle SN	*CTL	[000 to 999 / - / 1 / step]

211	On-Buckle SN	*CTL	[000 to 999 / - / 1 / step]
212	Off-Regist SN	*CTL	[000 to 999 / - / 1 / step]
213	On-Regist SN	*CTL	[000 to 999 / - / 1 / step]
214	Off-Exit SN	*CTL	[000 to 999 / - / 1 / step]
215	On-Exit SN	*CTL	[000 to 999 / - / 1 / step]

7506	[Paper Jam/Size]		
005	A4 LEF	*CTL	<p>Displays the number of jams according to the paper size.</p> <p>[0 to 9999 / 0 / 1 sheet / step]</p>
006	A5 LEF	*CTL	
014	B5 LEF	*CTL	
038	LT LEF	*CTL	
044	HLT LEF	*CTL	
132	A3 SEF	*CTL	
133	A4 SEF	*CTL	
134	A5 SEF	*CTL	
141	B4 SEF	*CTL	
142	B5 SEF	*CTL	
160	DLT SEF	*CTL	
164	LG SEF	*CTL	
166	LT SEF	*CTL	
172	HLT SEF	*CTL	
255	Others	*CTL	

7507	[Dspl-P Jam Hist] (D158/D159) [Dsply-P Jam Hist] (D160/D161/D170) Paper Jam History Display		
	Logs and displays the 10 most recently detected paper jams. (CODE, SIZE, TOTAL, DATE)		
001	Latest	*CTL	[- / - / -]
002	Latest 1	*CTL	
003	Latest 2	*CTL	
004	Latest 3	*CTL	
005	Latest 4	*CTL	
006	Latest 5	*CTL	
007	Latest 6	*CTL	
008	Latest 7	*CTL	
009	Latest 8	*CTL	
010	Latest 9	*CTL	
7508	[Original Jam History] (D158/D159) [Dsply-O Jam Hist] (D160/D161/D170)		
	Logs and displays the 10 most recently detected Original document jams. (CODE, SIZE, TOTAL, DATE)		

001	Latest	*CTL	[- / - / -]
002	Latest 1	*CTL	
003	Latest 2	*CTL	
004	Latest 3	*CTL	
005	Latest 4	*CTL	
006	Latest 5	*CTL	
007	Latest 6	*CTL	
008	Latest 7	*CTL	
009	Latest 8	*CTL	
010	Latest 9	*CTL	

7624	[Parts PM Use Setting] (D158/D159)		
	Part Replacement Operation ON/OFF Selects the PM maintenance for each part.		
001	Drum unit: Bk	*CTL	[0 or 1 / 1 / 1 / step] 0: Not PM maintenance 1: PM maintenance
002	Drum unit: M	*CTL	
003	Drum unit: C	*CTL	
004	Drum unit: Y	*CTL	
005	Development unit: Bk	*CTL	
006	Development unit: M	*CTL	
007	Development unit: C	*CTL	
008	Development unit: Y	*CTL	
009	Developer: Bk	*CTL	
010	Developer: M	*CTL	
011	Developer: C	*CTL	
012	Developer: Y	*CTL	

013	Image Transfer Belt	*CTL	[0 or 1 / 1 / 1 / step] 0: Not PM maintenance 1: PM maintenance
014	Image Transfer Cleaning Unit	*CTL	
015	Fusing Unit	*CTL	
016	Paper Transfer Roller Unit	*CTL	
017	Waste Toner bottle	*CTL	
018	Fusing Roller	*CTL	
019	Pressure Roller	*CTL	

7801	[ROM Info] (D158/D159)		
	Displays ROM numbers in the machine.		
002	Engine	ENG	[- / - / -]
005	ADF	ENG	
009	Bank	ENG	
102	Firmware Version Engine	ENG	
105	Firmware Version ADF	ENG	
109	Firmware Version Bank	ENG	
255	Rom_Version	CTL	Displays the part number and version of all ROMs in the machine.

7801	[Memory/Version/PN] (D160/D161/D170)		
	Displays ROM numbers in the machine.		
002	BICU	ENG	[- / - / -]
005	ADF	ENG	
009	BANK	ENG	
015	Printer/Scanner	ENG	

7803	[Display-PM Count]		
	Displays the PM counter for each unit.		
001	Paper	*CTL	-
002	Sheets 60k part	*ENG	Displays the number of pages printed. [0 to 9999999 / - / 1 sheet / step]
003	Sheets 120k part	*ENG	
004	Distance(mm)60k	*ENG	Displays the rotation distance. [0 to 999999999 / - / 1 mm/step]
005	Distance(mm)120k	*ENG	
006	Distance60k	*ENG	[0 to 255/ - / 1 /step]
007	Distance120k	*ENG	

7804	[Reset-PM Count]		
	Clears the PM counter. Press the Enter key after the machine asks "Execute?", which will store the PM counter value in SP7-906 (PM Counter - Previous) and reset the value of the current PM counter (SP7-803) to "0".		
001	Paper	CTL	[- / - / -] [Execute]
002	60k part	ENG	Clears the unit counter for each unit. [- / - / -] [Execute]
003	120k part	ENG	

7807	[Reset-SC/Jam]		
	Resets the SC, paper, original, and total jam counters. When the program ends normally, the message "Completed" is displayed. Note <ul style="list-style-type: none"> SP7-807-1 does not reset the following logs: SP7-507 (Display-Paper Jam History) and SP7-508 (Display-Original Jam History). 		
001	Reset-SC/Jam	CTL	[- / - / -] [Execute]

7808	[Reset-Counters] (D160/D161/D170)		
	Clears the all counters. <div style="border: 1px solid blue; border-radius: 10px; padding: 2px; display: inline-block;"> ↓ Note </div> <ul style="list-style-type: none"> • Clears all counters below. • SP7-001-001 (Basic model only) • SP7-804-001 • SP7-807-001 • SP7-992-004 (Basic model only) • SP8-192-001 • SP8-422 • SP8-442 • SP8-451 • SP8-462 • SP8-522-001 		
001	Reset-SC/Jam	CTL	[- / - / -] [Execute]

7810	[Reset-Key Op Code] (D160/D161/D170)		
	Clears the access code.		
001	Reset-Key Op Code	CTL	[- / - / -] [Execute]

7826	[MF Error Counter] (D158/D159)		
	Displays the counter that couldn't send count command to the MF charging device.		
001	Error Staple	*CTL	[0 to 9999999 / - / 1 / step]
002	Error Total	*CTL	[0 to 9999999 / - / 1 / step]

7826	[Dsply-KeyCard Err] (D160/D161/D170)		
	Displays the counter that couldn't send count command to the MF charging device.		
001	Error Total	*CTL	[0 to 9999999 / - / 1 / step]

7827	[MF Error Counter Clear] (D158/D159)		
	[Reset KeyCard Err] (D160/D161/D170)		
	Clears MF Error Counter (SP7-826).		
001	-	ENG	[- / - / -] [Execute]
7832	[Display-Self-Diag]		
001	Display-Self-Diag	CTL	Displays the result of the diagnostics. To scroll the return codes, press the up-arrow key or the down-arrow key.
7836	[Resident Memory] (D158/D159)		
001	Resident Memory	CTL	Displays the memory capacity of the controller system.
7851	[-] (D158/D159)		
	-		
001	-	*ENG	[0 to 255 / 0 / 1 / step]
7852	[DF Glass Dust Check Dust Detection] (D158/D159)		
	Dust detection counter of reading glass unit in document feeder		
001	Counter	*ENG	[0 to 65535 / - / 1 / step]
002	Clear Counter	*ENG	[0 to 65535 / 0 / 1 / step]
7856	[Zero cross] (D158/D159)		
001	count value	*ENG	[0 to 255 / 0 / 1 / step]
	Records the count value at the time of frequency detection.		
7901	[Assert Info.] (D158/D159)		

001	File Name	*CTL	Records the location where a problem is detected in the program. The data stored in this SP is used for problem analysis.
002	Number of Lines	*CTL	
003	Location	*CTL	

7906	[Last PM Count] Previous Unit Counter Display		
	Copies the life counter to this sp as a previous counter when the life counter is cleared.		
002	Sheets 60k part	*ENG	Displays the number of pages printed with the previous unit counter. [0 to 9999999 / - / 1 sheet / step]
003	Sheets 120k part	*ENG	
004	Distance(mm)60k	*ENG	[0 to 999999999 / - / 1 mm / step]
005	Distance(mm)120k	*ENG	
006	Distance60k	*ENG	[0 to 255 / - / 1 / step]
007	Distance 120k	*ENG	

7907	[Before 2 PM Count]		
002	Sheets 60k part	*ENG	[0 to 9999999 / - / 1 mm/step]
003	Sheets 120k part	*ENG	
004	Distance(mm) 60k	*ENG	
005	Distance(mm) 120k	*ENG	
006	Distance60k	*ENG	[0 to 255 / - / 1 / step]
007	Distance 120k	*ENG	

7908	[Before 3 PM Count]		
002	Sheets 60k part	*ENG	[0 to 9999999 / - / 1 sheet / step]
003	Sheets 120k part	*ENG	
004	Distance(mm) 60k	*ENG	[0 to 9999999 / - / 1 mm / step]
005	Distance(mm) 120k	*ENG	

006	Distance60k	*ENG	[0 to 255 / - / 1 / step]
007	Distance120k	*ENG	

7935	[Toner Bottle Log 1: Bk] (D158/D159)		
001	SerialNo.	*ENG	Displays the current serial numbers and installation date.
002	Attachment Date	*ENG	
7935	[Toner Bottle Log 2: Bk] (D158/D159)		
005	SerialNo.	*ENG	Displays the previous serial numbers and installation date.
006	Attachment Date	*ENG	
7935	[Toner Bottle Log 3: Bk] (D158/D159)		
009	SerialNo.	*ENG	Displays the serial numbers and installation date the past 2 times before.
010	Attachment Date	*ENG	
7935	[Toner Bottle Log 4: Bk] (D158/D159)		
013	SerialNo.	*ENG	Displays the serial numbers and installation date the past 3 times before.
014	Attachment Date	*ENG	
7935	[Toner Bottle Log 5: Bk] (D158/D159)		
017	SerialNo.	*ENG	Displays the serial numbers and installation date the past 4 times before.
018	Attachment Date	*ENG	
7935	[Toner Bottle Log 6: Bk]		
021	SerialNo.	*ENG	Displays the serial numbers and installation date the past 5 times before.
022	Attachment Date	*ENG	
7935	[Toner Bottle Log 7: Bk] (D158/D159)		
025	SerialNo.	*ENG	Displays the serial numbers and installation date the past 6 times before.
026	Attachment Date	*ENG	
7935	[Toner Bottle Log 8: Bk] (D158/D159)		

029	SerialNo.	*ENG	Displays the serial numbers and installation date the past 7 times before.
030	Attachment Date	*ENG	
7935	[Toner Bottle Log 9: Bk] (D158/D159)		
033	SerialNo.	*ENG	Displays the serial numbers and installation date the past 8 times before.
034	Attachment Date	*ENG	
7935	[Toner Bottle Log 10: Bk] (D158/D159)		
037	SerialNo.	*ENG	Displays the serial numbers and installation date the past 9 times before.
038	Attachment Date	*ENG	

7991	[Dsply-Info Count] (D160/D161/D170)		
	Displays the total operating time or the total number of operations. The time is displayed in the following format: day: hour: minute: second.		
001	Dsply-Timer Count	ENG	Displays the total time while machine is on.
002	Dsply-APS Working	ENG	Displays the total time while APS is working. [0 to 99999999 / - / 1 min / step]
003	Dsply-ID S Work	ENG	Displays the ID sensor operating time. [0 to 99999999 / - / 1 sec / step]
004	Dsply-Dev Counter	ENG	Developer counter. [0 to 99999999 / - / 1 mm / step]
005	Dsply-ID Er Count	ENG	ID sensor error detected counter. [0 to 255 / - / 1 / step]

7992	[Reset-Info Count] (D160/D161/D170)		
001	Reset-Timer Count	ENG	Resets the total time (SP7-991-001) [- / - / -] [Execute]

005	Reset-ID Er Count	ENG	Resets ID sensor error detected counter. (SP7-991-005) [- / - / -] [Execute]
-----	-------------------	-----	---

System SP Tables-8

SP8-xxx: Data Log 2

Many of these counters are provided for features that are currently not available, such as sending color faxes, and so on. However, here are some Group 8codes that when used in combination with others, can provide useful information.

3

SP Numbers	What They Do
SP8211 to SP8216	The number of pages scanned to the document server.
SP8401 to SP8406	The number of pages printed from the document server.
SP8691 to SP8696	The number of pages sent from the document server.

Specifically, the following questions can be answered:

How is the document server actually being used?

What application is using the document server most frequently?

What data in the document server is being reused?

Most of the SPs in this group are prefixed with a letter that indicates the mode of operation (the mode of operation is referred to as an 'application'). Before reading the Group 8 Service Table, make sure that you understand what these prefixes mean.

Prefixes	What It Means	
T:	Total: (Grand Total).	Grand total of the items counted for all applications (C, F, P, etc.).
C:	Copy application.	Totals (pages, jobs, etc.) executed for each application when the job was not stored on the document server.
F:	Fax application.	
P:	Print application.	
S:	Scan application.	

L:	Local storage (document server)	Totals (jobs, pages, etc.) for the document server. The L: counters work differently case by case. Sometimes, they count jobs/pages stored on the document server; this can be in document server mode (from the document server window), or from another mode, such as from a printer driver or by pressing the Store File button in the Copy mode window. Sometimes, they include occasions when the user uses a file that is already on the document server. Each counter will be discussed case by case.
O:	Other applications (external network applications, for example)	Refers to network applications such as Web Image Monitor. Utilities developed with the SDK (Software Development Kit) will also be counted with this group in the future.

The Group 8 SP codes are limited to 17 characters, forced by the necessity of displaying them on the small LCDs of printers and faxes that also use these SPs. Read over the list of abbreviations below and refer to it again if you see the name of an SP that you do not understand.

Key for Abbreviations

Abbreviation	What It Means
/	"By", e.g. "T:Jobs/Apl" = Total Jobs "by" Application
>	More (2> "2 or more", 4> "4 or more"
AddBook	Address Book
Apl	Application
B/W	Black & White
Bk	Black
C	Cyan
ColCr	Color Create
ColMode	Color Mode
Comb	Combine
Comp	Compression
Deliv	Delivery

Abbreviation	What It Means
DesApl	Designated Application. The application (Copy, Fax, Scan, Print) used to store the job on the document server, for example.
Dev Counter	Development Count, no. of pages developed.
Dup, Duplex	Duplex, printing on both sides
Emul	Emulation
FC	Full Color
FIN	Post-print processing, i.e. finishing (punching, stapling, etc.)
Full Bleed	No Margins
GenCopy	Generation Copy Mode
GPC	Get Print Counter. For jobs 10 pages or less, this counter does not count up. For jobs larger than 10 pages, this counter counts up by the number that is in excess of 10 (e.g., for an 11-page job, the counter counts up $11-10=1$)
IFax	Internet Fax
ImgEdt	Image Edit performed on the original with the copier GUI, e.g. border removal, adding stamps, page numbers, etc.
K	Black (YMCK)
LS	Local Storage. Refers to the document server.
LSize	Large (paper) Size
Mag	Magnification
MC	One color (monochrome)
NRS	New Remote Service, which allows a service center to monitor machines remotely. "NRS" is used overseas, "CSS" is used in Japan.
Org	Original for scanning
OrgJam	Original Jam

Abbreviation	What It Means
Palm 2	Print Job Manager/Desk Top Editor: A pair of utilities that allows print jobs to be distributed evenly among the printers on the network, and allows files to moved around, combined, and converted to different formats.
PC	Personal Computer
PGS	Pages. A page is the total scanned surface of the original. Duplex pages count as two pages, and A3 simplex count as two pages if the A3/DLT counter SP is switched ON.
PJob	Print Jobs
Ppr	Paper
PrtJam	Printer (plotter) Jam
PrtPGS	Print Pages
R	Red (Toner Remaining). Applies to the wide format model A2 only. This machine is under development and currently not available.
Rez	Resolution
SC	Service Code (Error SC code displayed)
Scn	Scan
Sim, Simplex	Simplex, printing on 1 side.
S-to-Email	Scan-to-E-mail
SMC	SMC report printed with SP5990. All of the Group 8counters are recorded in the SMC report.
Svr	Server
TonEnd	Toner End
TonSave	Toner Save
TXJob	Send, Transmission
YMC	Yellow, Magenta, Cyan
YMCK	Yellow, Magenta, Cyan, Black

Note

- All of the Group 8 SPs are reset with SP5 801-1 Memory All Clear.

8191	T:Total Scan PGS	*CTL	These SPs count the pages scanned by each application that uses the scanner to scan images. [0 to 9999999 / 0 / 1]
8192	C:Total Scan PGS	*CTL	
8193	F:Total Scan PGS (D158/ D159)	*CTL	
8195	S:Total Scan PGS	*CTL	
8196	L:Total Scan PGS (D158/ D159)	*CTL	

- SP 8191 to 8196 count the number of scanned sides of pages, not the number of physical pages.
- These counters do not count reading user stamp data, or reading color charts to adjust color.
- Previews done with a scanner driver are not counted.
- A count is done only after all images of a job have been scanned.
- Scans made in SP mode are not counted.

Examples

- If 3 B5 pages and 1 A3 page are scanned with the scanner application but not stored, the S: count is 4.
- If both sides of 3 A4 sheets are copied and stored to the document server using the Store File button in the Copy mode window, the C: count is 6 and the L: count is 6.
- If both sides of 3 A4 sheets are copied but not stored, the C: count is 6.
- If you enter document server mode then scan 6 pages, the L: count is 6.

8201	T:LSize Scan PGS (D158/ D159)	*CTL	[0 to 9999999 / 0 / 1]
8203	F Lsize Scan PGS (D158/ D159)	*CTL	[0 to 9999999 / 0 / 1]
8205	S:LSize Scan PGS (D158/ D159)	*CTL	[0 to 9999999 / 0 / 1]
	These SP codes count the total number of large pages input with the scanner for scan jobs only. Large size paper (A3/DLT) scanned for fax transmission are not counted. Note: These counters are displayed in the SMC Report, and in the User Tools display..		

8221	ADF Org Feeds	*CTL	[0 to 9999999 / 0 / 1]
	These SPs count the number of pages fed through the ADF for front and back side scanning.		
001	Front	<p>Number of front sides fed for scanning:</p> <p>With an ADF that can scan both sides simultaneously, the Front side count is the same as the number of pages fed for either simplex or duplex scanning.</p> <p>With an ADF that cannot scan both sides simultaneously, the Front side count is the same as the number of pages fed for duplex front side scanning. (The front side is determined by which side the user loads face up.)</p>	
002	Back	<p>Number of rear sides fed for scanning:</p> <p>With an ADF that can scan both sides simultaneously, the Back count is the same as the number of pages fed for duplex scanning.</p> <p>With an ADF that cannot scan both sides simultaneously, the Back count is the same as the number of pages fed for duplex rear-side scanning.</p>	

- When 1 sheet is fed for duplex scanning the Front count is 1 and the Back count is 1.
- If a jam occurs during the job, recovery processing is not counted to avoid double counting. Also, the pages are not counted if the jam occurs before the first sheet is output.

8281	T:Scan PGS/TWAIN (D158/D159)	*CTL	<p>These SPs count the number of pages scanned using a TWAIN driver. These counters reveal how the TWAIN driver is used for delivery functions.</p> <p>[0 to 9999999 / 0 / 1]</p> <p>Note: At the present time, these counters perform identical counts.</p>
8285	S:Scan PGS/TWAIN (D158/D159)	*CTL	

8291	T:Scan PGS/Stamp (D158/D159)	*CTL	<p>These SPs count the number of pages stamped with the stamp in the ADF unit.</p> <p>[0 to 9999999 / 0 / 1]</p> <p>The L: counter counts the number of pages stored from within the document server mode screen at the operation panel, and with the Store File button from within the Copy mode screen</p>
8293	F:Scan PGS/Stamp (D158/D159)	*CTL	
8295	S:Scan PGS/Stamp (D158/D159)	*CTL	

3

8301	T:Scan PGS/Size (D158/D159)	*CTL	[0 to 9999999 / 0 / 1]
	<p>These SPs count by size the total number of pages scanned by all applications. Use these totals to compare original page size (scanning) and output (printing) page size [SP 8-441].</p>		
8302	C:Scan PGS/Size (D158/D159)	*CTL	[0 to 9999999 / 0 / 1]
	<p>These SPs count by size the total number of pages scanned by the Copy application. Use these totals to compare original page size (scanning) and output (printing) page size [SP 8-442].</p>		
8303	F:Scan PGS/Size (D158/D159)	*CTL	[0 to 9999999 / 0 / 1]
	<p>These SPs count by size the total number of pages scanned by the Fax application. Use these totals to compare original page size (scanning) and output page size [SP 8-443].</p>		
8305	S:Scan PGS/Size (D158/D159)	*CTL	[0 to 9999999 / 0 / 1]
	<p>These SPs count by size the total number of pages scanned by the Scan application. Use these totals to compare original page size (scanning) and output page size [SP 8-445].</p>		
8306	L:Scan PGS/Size (D158/D159)	*CTL	[0 to 9999999 / 0 / 1]
	<p>These SPs count by size the total number of pages scanned and stored from within the document server mode screen at the operation panel, and with the Store File button from within the Copy mode screen. Use these totals to compare original page size (scanning) and output page size [SP 8-446].</p>		

001	A3	
002	A4	
003	A5	
004	B4	
005	B5	
006	DLT	
007	LG	
008	LT	
009	HLT	
010	Full Bleed	
254	Other (Standard)	
255	Other (Custom)	

8381	T:Total PrtPGS	* CTL	<p>These SPs count the number of pages printed by the customer. The counter for the application used for storing the pages increments.</p> <p>[0 to 9999999 / 0 / 1]</p> <p>The L: counter counts the number of pages stored from within the document server mode screen at the operation panel. Pages stored with the Store File button from within the Copy mode screen go to the C: counter.</p>
8382	C:Total PrtPGS	* CTL	
8383	F:Total PrtPGS (D158/ D159)	* CTL	
8384	P:Total PrtPGS	* CTL	
8385	S:Total PrtPGS (D158/ D159)	* CTL	
8386	L:Total PrtPGS (D158/ D159)	* CTL	
8387	O:Total PrtPGS (D158/ D159)	* CTL	

- When the A3/DLT double count function is switched on with SP5104, 1 A3/DLT page is counted as 2.
- When several documents are merged for a print job, the number of pages stored are counted for the application that stored them.

- These counters are used primarily to calculate charges on use of the machine, so the following pages are not counted as printed pages: the following pages are not counted as printed pages:
 - Blank pages in a duplex printing job.
 - Blank pages inserted as document covers, chapter title sheets, and slip sheets.
 - Reports printed to confirm counts.
 - All reports done in the service mode (service summaries, engine maintenance reports, etc.)
 - Test prints for machine image adjustment.
 - Error notification reports.
 - Partially printed pages as the result of a copier jam.

8391	LSize PrtPGS	*CTL	[0 to 99999999 / 0 / 1]
	These SPs count pages printed on paper sizes A3/DLT and larger. Note: In addition to being displayed in the SMC Report, these counters are also displayed in the User Tools display on the copy machine.		
8411	Prints/Duplex	*CTL	This SP counts the amount of paper (front/back counted as 1 page) used for duplex printing. Last pages printed only on one side are not counted. [0 to 99999999 / 0 / 1]
8421	T:PrtPGS/Dup Comb (D158/D159)	*CTL	[0 to 99999999 / 0 / 1]
	These SPs count by binding and combine, and n-Up settings the number of pages processed for printing. This is the total for all applications.		
8422	C:PrtPGS/Dup Comb	*CTL	[0 to 99999999 / 0 / 1]
	These SPs count by binding and combine, and n-Up settings the number of pages processed for printing by the copier application.		
8423	F:PrtPGS/Dup Comb (D158/D159)	*CTL	[0 to 99999999 / 0 / 1]
	These SPs count by binding and combine, and n-Up settings the number of pages processed for printing by the fax application.		
8424	P:PrtPGS/Dup Comb (D158/D159)	*CTL	[0 to 99999999 / 0 / 1]
	These SPs count by binding and combine, and n-Up settings the number of pages processed for printing by the printer application.		

8425	S:PrtPGS/Dup Comb (D158/D159)	*CTL	[0 to 9999999 / 0 / 1]
	These SPs count by binding and combine, and n-Up settings the number of pages processed for printing by the scanner application.		
8426	L:PrtPGS/Dup Comb (D158/D159)	*CTL	[0 to 9999999 / 0 / 1]
	These SPs count by binding and combine, and n-Up settings the number of pages processed for printing from within the document server mode window at the operation panel.		
8427	O:PrtPGS/Dup Comb (D158/D159)	*CTL	[0 to 99999999 / 0 / 1]
	These SPs count by binding and combine, and n-Up settings the number of pages processed for printing by Other applications.		
001	Simplex> Duplex		
002	Duplex> Duplex		
003	Book> Duplex (D158/D159)		
004	Simplex Combine		
005	Duplex Combine		
006	2in1	2 pages on 1 side (2-Up)	
007	4in1	4 pages on 1 side (4-Up)	
008	6in1 (D158/D159)	6 pages on 1 side (6-Up)	
009	8in1 (D158/D159)	8pages on 1 side (8-Up)	
010	9in1 (D158/D159)	9 pages on 1 side (9-Up)	
011	16in1 (D158/D159)	16 pages on 1 side (16-Up)	
012	Booklet (D158/D159)		
013	Magazine (D158/D159)		
014	2in1 + Booklet (D158/D159)		
015	4in1 + Booklet (D158/D159)		

016	6in1 + Booklet (D158/D159)	
017	8in1 + Booklet (D158/D159)	
018	9in1 + Booklet (D158/D159)	
019	2in1 + Magazine (D158/D159)	
020	4in1 + Magazine (D158/D159)	
021	6in1 + Magazine (D158/D159)	
022	8in1 + Magazine (D158/D159)	
023	9in1 + Magazine (D158/D159)	
024	16in1 + Magazine (D158/D159)	

- These counts (SP8421 to SP8427) are especially useful for customers who need to improve their compliance with ISO standards for the reduction of paper consumption.
- Pages that are only partially printed with the n-Up functions are counted as 1 page.
- Here is a summary of how the counters work for Booklet and Magazine modes:

Booklet		Magazine	
Original Pages	Count	Original Pages	Count
1	1	1	1
2	2	2	2
3	2	3	2
4	2	4	2
5	3	5	4
6	4	6	4
7	4	7	4
8	4	8	4

8441	T:PrtPGS/Ppr Size	*CTL	[0 to 9999999 / 0 / 1]
	These SPs count by print paper size the number of pages printed by all applications.		

8442	C:PrtPGS/Ppr Size	*CTL	[0 to 9999999 / 0 / 1]
	These SPs count by print paper size the number of pages printed by the copy application.		
8443	F:PrtPGS/Ppr Size (D158/ D159)	*CTL	[0 to 9999999 / 0 / 1]
	These SPs count by print paper size the number of pages printed by the fax application.		
8444	P:PrtPGS/Ppr Size	*CTL	[0 to 9999999 / 0 / 1]
	These SPs count by print paper size the number of pages printed by the printer application.		
8445	S:PrtPGS/Ppr Size (D158/ D159)	*CTL	[0 to 9999999 / 0 / 1]
	These SPs count by print paper size the number of pages printed by the scanner application.		
8446	L:PrtPGS/Ppr Size (D158/ D159)	*CTL	[0 to 9999999 / 0 / 1]
	These SPs count by print paper size the number of pages printed from within the document server mode window at the operation panel.		
8447	O:PrtPGS/Ppr Size (D158/ D159)	*CTL	[0 to 9999999 / 0 / 1]
	These SPs count by print paper size the number of pages printed by Other applications.		
001	A3		
002	A4		
003	A5		
004	B4		
005	B5		
006	DLT		
007	LG		
008	LT		
009	HLT		
010	Full Bleed (D158/D159)		

254	Other (Standard)	
255	Other (Custom)	

- These counters do not distinguish between LEF and SEF.

8451	PrtPGS/Ppr Tray	*CTL	[0 to 9999999 / 0 / 1]
	These SPs count the number of sheets fed from each paper feed station.		
001	Bypass Tray	Bypass Tray	
002	Tray 1	Copier	
003	Tray 2	Copier	
004	Tray 3	Paper Tray Unit (Option)	
005	Tray 4	Paper Tray Unit (Option)	
006	Tray 5 (D158/D159)	LCT (Option)	
007	Tray 6 (D158/D159)	Currently not used.	
008	Tray 7 (D158/D159)	Currently not used.	
009	Tray 8 (D158/D159)	Currently not used.	
010	Tray 9 (D158/D159)	Currently not used.	
011	Tray 10 (D158/D159)	Currently not used.	
012	Tray 11 (D158/D159)	Currently not used.	
013	Tray 12 (D158/D159)	Currently not used.	
014	Tray 13 (D158/D159)	Currently not used.	
015	Tray 14 (D158/D159)	Currently not used.	
016	Tray 15 (D158/D159)	Currently not used.	

8461	T:PrtPGS/Ppr Type	*CTL	[0 to 9999999 / 0 / 1]
	<p>These SPs count by paper type the number pages printed by all applications.</p> <p>These counters are not the same as the PM counter. The PM counter is based on feed timing to accurately measure the service life of the feed rollers. However, these counts are based on output timing.</p> <p>Blank sheets (covers, chapter covers, slip sheets) are also counted.</p> <p>During duplex printing, pages printed on both sides count as 1, and a page printed on one side counts as 1.</p>		
8462	C:PrtPGS/Ppr Type	*CTL	[0 to 9999999 / 0 / 1]
	These SPs count by paper type the number pages printed by the copy application.		
8463	F:PrtPGS/Ppr Type (D158/D159)	*CTL	[0 to 9999999 / 0 / 1]
	These SPs count by paper type the number pages printed by the fax application.		
8464	P:PrtPGS/Ppr Type	*CTL	[0 to 9999999 / 0 / 1]
	These SPs count by paper type the number pages printed by the printer application.		
8466	L:PrtPGS/Ppr Type (D158/D159)	*CTL	[0 to 9999999 / 0 / 1]
	These SPs count by paper type the number pages printed from within the document server mode window at the operation panel.		
001	Normal		
002	Recycled (D158/D159)		
003	Special (D158/D159)		
004	Thick		
005	Normal (Back) (D158/D159)		
006	Thick (Back) (D158/D159)		
007	OHP		
008	Other		

8511	T:PrtPGS/Emul (D158/ D159)	*CTL	[0 to 9999999 / 0 / 1]
	These SPs count by printer emulation mode the total number of pages printed.		
8514	P:PrtPGS/Emul (D158/ D159)	*CTL	[0 to 9999999 / 0 / 1]
	These SPs count by printer emulation mode the total number of pages printed.		
001	RPCS		
002	RPDL	Japan Only	
003	PS3		
004	R98	Japan Only	
005	R16		
006	GL/GL2		
007	R55		
008	RTIFF		
009	PDF		
010	PCL5e/5c		
011	PCL XL		
012	IPDL-C		
013	BM-Links	Japan Only	
014	Other		
015	IPDS		

- SP8511 and SP8514 return the same results as they are both limited to the Print application.
- Print jobs output to the document server are not counted.

8521	T:PrtPGS/FIN (D158/ D159)	*CTL	[0 to 9999999 / 0 / 1]
	These SPs count by finishing mode the total number of pages printed by all applications.		

8522	C:PrtPGS/FIN	*CTL	[0 to 9999999 / 0 / 1]
	These SPs count by finishing mode the total number of pages printed by the Copy application.		
8523	F:PrtPGS/FIN (D158/D159)	*CTL	[0 to 9999999 / 0 / 1]
	These SPs count by finishing mode the total number of pages printed by the Fax application. Note: Print finishing options for received faxes are currently not available.		
8524	P:PrtPGS/FIN (D158/D159)	*CTL	[0 to 9999999 / 0 / 1]
	These SPs count by finishing mode the total number of pages printed by the Print application.		
8525	S:PrtPGS/FIN (D158/D159)	*CTL	[0 to 9999999 / 0 / 1]
	These SPs count by finishing mode the total number of pages printed by the Scanner application.		
8526	L:PrtPGS/FIN (D158/D159)	*CTL	[0 to 9999999 / 0 / 1]
	These SPs count by finishing mode the total number of pages printed from within the document server mode window at the operation panel.		
001	Sort		
002	Stack (D158/D159)		
003	Staple (D158/D159)		
004	Booklet (D158/D159)		
005	Z-Fold (D158/D159)		
006	Punch (D158/D159)		
007	Other (D158/D159)		
008	Inside-Fold (D158/D159)		
009	Three-IN-Fold (D158/D159)		

010	Three-OUT-Fold (D158/D159)
011	Four-Fold (D158/D159)
012	KANNON-Fold (D158/D159)
013	Perfect-Bind (D158/D159)
014	Ring-Bind (D158/D159)

Note

- If stapling is selected for finishing and the stack is too large for stapling, the unstapled pages are still counted.
- The counts for staple finishing are based on output to the staple tray, so jam recoveries are counted.

8531	Staples (D158/D159)	*CTL	This SP counts the amount of staples used by the machine. [0 to 9999999 / 0 / 1]
------	---------------------	------	---

8551	T:PrtBooks/FIN (D158/D159)		
8552	C:PrtBooks/FIN (D158/D159)		
8554	P:PrtBooks/FIN (D158/D159)		
8556	L:PrtBooks/FIN (D158/D159)		
001	Perfect-Bind	*CTL	Not Used
002	Ring-Bind	*CTL	Not Used

8581	T: Counter (D158/D159)	*CTL	[0 to 9999999 / 0 / 1]
	<p>These SPs count the total output broken down by color output, regardless of the application used. In addition to being displayed in the SMC Report, these counters are also displayed in the User Tools display on the copy machine.</p> <p>Note: This SP is expanded for color MFP and color LP machines. For this machine, the count is done for black only.</p>		

8561	T:A Sheet Of Paper (D158/D159)
8562	C:A Sheet Of Paper (D158/D159)

8563	F:A Sheet Of Paper (D158/D159)		
8564	P:A Sheet Of Paper (D158/D159)		
8566	L:A Sheet Of Paper (D158/D159)		
8567	O:A Sheet Of Paper (D158/D159)		
	These SPs count the totals number of duplex pages printed.		
001	Total: Over A3/DLT	*CTL	[0 to 9999999 / 0 / 1]
002	Total: Under A3/DLT	*CTL	
003	Duplex: Over A3/DLT	*CTL	
004	Duplex: Under A3/DLT	*CTL	

8591	O: Counter (D158/D159)		
	These SPs count the totals for A3/DLT paper use, number of duplex pages printed, and the number of staples used. These totals are for Other (O:) applications only.		
001	A3/DLT	*CTL	[0 to 9999999 / 0 / 1]
002	Duplex	*CTL	

8601	T:Coverage Counter (D158/D159)		
	These SPs count the total coverage for each color and printout pages.		
001	B/W	*CTL	[0 to 2147483647 / 0 / 1]
011	B/W Printing Pages	*CTL	[0 to 9999999 / 0 / 1]

8602	C:Coverage Counter (D158/D159)	*CTL	[0 to 2147483647 / 0 / 1]
	These SPs count the total coverage for B/W.		
8603	F:Coverage Counter (D158/D159)	*CTL	[0 to 2147483647 / 0 / 1]
	These SPs count the total coverage for B/W.		

8604	P:Coverage Counter (D158/D159)	*CTL	[0 to 2147483647 / 0 / 1]
	These SPs count the total coverage for B/W.		
8606	L:Coverage Counter (D158/D159)	*CTL	[0 to 2147483647 / 0 / 1]
	These SPs count the total coverage for B/W.		

8617	SDK Apli Counter (D158/D159)		
	These SPs count the total printout pages for each SDK applicaion.		
001	SDK-1	*CTL	[0 to 9999999 / 0 / 1]
002	SDK-2	*CTL	
003	SDK-3	*CTL	
004	SDK-4	*CTL	
005	SDK-5	*CTL	
006	SDK-6	*CTL	

8621	Func Use Counter (D158/D159)		
	-		
001	Function-001	*CTL	[0 to 99999999 / 0 / 1]
002	Function-002	*CTL	
003	Function-003	*CTL	
004	Function-004	*CTL	
005	Function-005	*CTL	

006	Function-006	*CTL	[0 to 99999999 / 0 / 1]
007	Function-007	*CTL	
008	Function-008	*CTL	
009	Function-009	*CTL	
010	Function-010	*CTL	
011	Function-011	*CTL	[0 to 99999999 / 0 / 1]
012	Function-012	*CTL	
013	Function-013	*CTL	
014	Function-014	*CTL	
015	Function-015	*CTL	
016	Function-016	*CTL	[0 to 99999999 / 0 / 1]
017	Function-017	*CTL	
018	Function-018	*CTL	
019	Function-019	*CTL	
020	Function-020	*CTL	
021	Function-021	*CTL	[0 to 99999999 / 0 / 1]
022	Function-022	*CTL	
023	Function-023	*CTL	
024	Function-024	*CTL	
025	Function-025	*CTL	
026	Function-026	*CTL	[0 to 99999999 / 0 / 1]
027	Function-027	*CTL	
028	Function-028	*CTL	
029	Function-029	*CTL	
030	Function-030	*CTL	

031	Function-031	*CTL	[0 to 99999999 / 0 / 1]
032	Function-032	*CTL	
033	Function-033	*CTL	
034	Function-034	*CTL	
035	Function-035	*CTL	
036	Function-036	*CTL	
037	Function-037	*CTL	
038	Function-038	*CTL	
039	Function-039	*CTL	
040	Function-040	*CTL	
041	Function-041	*CTL	[0 to 99999999 / 0 / 1]
042	Function-042	*CTL	
043	Function-043	*CTL	
044	Function-044	*CTL	
045	Function-045	*CTL	
046	Function-046	*CTL	
047	Function-047	*CTL	
048	Function-048	*CTL	
049	Function-049	*CTL	
050	Function-050	*CTL	

051	Function-051	*CTL	[0 to 99999999 / 0 / 1]
052	Function-052	*CTL	
053	Function-053	*CTL	
054	Function-054	*CTL	
055	Function-055	*CTL	
056	Function-056	*CTL	
057	Function-057	*CTL	
058	Function-058	*CTL	
059	Function-059	*CTL	
060	Function-060	*CTL	
061	Function-061	*CTL	[0 to 99999999 / 0 / 1]
062	Function-062	*CTL	
063	Function-063	*CTL	
064	Function-064	*CTL	

8631	T:FAX TX PGS (D158/D159)		
	These SPs count by color mode the number of pages sent by fax to a telephone number.		
8633	F:FAX TX PGS (D158/D159)		
	These SPs count by color mode the number of pages sent by fax to a telephone number.		
001	B/W	*CTL	Black TX [0 to 9999999 / 0 / 1]

- If a document has color and black-and-white pages mixed, the pages are counted separately as B/W or Color.
- At the present time, this feature is provided for the Fax application only so SP8631 and SP8633 are the same.
- The counts include error pages.
- If a document is sent to more than one destination with a Group transmission, the count is done for each destination.

- Polling transmissions are counted but polling RX are not.
- Relay, memory, and confidential mailbox transmissions and are counted for each destination.

8641	T:FAX TX PGS (D158/D159)		
	These SPs count by color mode the number of pages sent by fax to as fax images using I-Fax.		
8643	F:FAX TX PGS (D158/D159)		
	These SPs count by color mode the number of pages sent by Fax as fax images using I-Fax.		
001	B/W	*CTL	Black TX [0 to 9999999 / 0 / 1]

- If a document has color and black-and-white pages mixed, the pages are counted separately as B/W or Color.
- At the present time, this feature is provided for the Fax application only so SP8641 and SP8643 are the same.
- The counts include error pages.
- If a document is sent to more than one destination with a Group transmission, the count is done for each destination.
- Polling transmissions are counted but polling RX are not.
- Relay, memory, and confidential mailbox transmissions and are counted for each destination.

8651	T:S-to-Email PGS (D158/D159)		
	These SPs count by color mode the total number of pages attached to an e-mail for both the Scan and document server applications.		
8655	S:S-to-Email PGS (D158/D159)		
	These SPs count by color mode the total number of pages attached to an e-mail for the Scan application only.		
001	B/W	*CTL	[0 to 9999999 / 0 / 1]
002	Color	*CTL	

Note

- The count for B/W and Color pages is done after the document is stored on the HDD. If the job is cancelled before it is stored, the pages are not counted.

- If Scan-to-Email is used to send a 10-page document to 5 addresses, the count is 10 (the pages are sent to the same SMTP server together).
- If Scan-to-PC is used to send a 10-page document to 5 folders, the count is 50 (the document is sent to each destination of the SMB/FTP server).
- Due to restrictions on some devices, if Scan-to-Email is used to send a 10-page document to a large number of destinations, the count may be divided and counted separately. For example, if a 10-page document is sent to 200 addresses, the count is 10 for the first 100 destinations and the count is also 10 for the second 100 destinations, for a total of 20).

8661	T:Deliv PGS/Svr (D158/D159)		
	These SPs count by color mode the total number of pages sent to a Scan Router server by both Scan and LS applications.		
8665	S:Deliv PGS/Svr (D158/D159)		
	These SPs count by color mode the total number of pages sent to a Scan Router server by the Scan application.		
001	B/W	*CTL	[0 to 9999999 / 0 / 1]
002	Color	*CTL	

Note

- The B/W and Color counts are done after the document is stored on the HDD of the Scan Router server.
- If the job is canceled before storage on the Scan Router server finishes, the counts are not done.
- The count is executed even if regardless of confirmation of the arrival at the Scan Router server.

8671	T: Deliv PGS/PC (D158/D159)		
	These SPs count by color mode the total number of pages sent to a folder on a PC (Scan-to-PC) with the Scan and LS applications.		
8675	S: Deliv PGS/PC (D158/D159)		
	These SPs count by color mode the total number of pages sent with Scan-to-PC with the Scan application.		
001	B/W	*CTL	[0 to 9999999 / 0 / 1]
002	Color	*CTL	

8681	T:PCFAX TXPGS (D158/D159)	*CTL	These SPs count the number of pages sent by PC Fax. These SPs are provided for the Fax application only, so the counts for SP8681 and SP8683 are the same. [0 to 9999999 / 0 / 1]
8683	F:PCFAX TXPGS (D158/D159)	*CTL	

- This counts pages sent from a PC using a PC fax application, from the PC through the copier to the destination.
- When sending the same message to more than one place using broadcasting, the pages are only counted once. (For example, a 10-page fax is sent to location A and location B. The counter goes up by 10, not 20.)

8701	TX PGS/Port (D158/D159)		
	These SPs count the number of pages sent by the physical port used to send them. For example, if a 3-page original is sent to 4 destinations via ISDN G4, the count for ISDN (G3, G4) is 12.		
001	PSTN-1	*CTL	[0 to 9999999 / 0 / 1]
002	PSTN-2	*CTL	
003	PSTN-3	*CTL	
004	ISDN (G3,G4)	*CTL	
005	Network	*CTL	

8711	T:Scan PGS/Comp (D158/D159)		
	These SPs count the number of compressed pages scanned into the document server, counted by the formats listed below.		
001	JPEG/JPEG2000	*CTL	[0 to 9999999 / 0 / 1]
002	TIFF (Multi/Single)	*CTL	
003	PDF	*CTL	
004	Other	*CTL	
005	PDF/Comp	*CTL	
006	PDF/A	*CTL	

8715	S:Scan PGS/Comp (D158/D159)		
	These SPs count the number of compressed pages scanned by the scan application, counted by the formats listed below.		
001	JPEG/JPEG2000	*CTL	[0 to 9999999 / 0 / 1]
002	TIFF (Multi/Single)	*CTL	
003	PDF	*CTL	
004	Other	*CTL	
005	PDF/Comp	*CTL	
006	PDF/A	*CTL	

8721	T:Deliv PGS/WSD (D158/D159)		
8725	S:Deliv PGS/WSD (D158/D159)		
	These SPs count the number of pages scanned by each scanner mode.		
001	B/W	*CTL	[0 to 9999999 / 0 / 1]
002	Color	*CTL	

8731	T:Scan PGS/Media (D158/D159)		
8735	S:Scan PGS/Media (D158/D159)		
	These SPs count the number of pages scanned and saved in a media by each scanner mode.		
001	B/W	*CTL	[0 to 9999999 / 0 / 1]
002	Color	*CTL	

8741	RX PGS/Port (D158/D159)		
	These SPs count the number of pages received by the physical port used to receive them.		

001	PSTN-1	*CTL	[0to99999999 / 0 / 1]
002	PSTN-2	*CTL	
003	PSTN-3	*CTL	
004	ISDN (G3,G4)	*CTL	
005	Network	*CTL	

8781	Toner_BotoL_Info. (D158/ D159)	*ENG	[0 to 99999999 / 0 / 1]
	This SP displays the number of toner bottles used. The count is done based on the equivalent of 1,000 pages per bottle.		

8801	Toner Remain (D158/ D159)	*CTL	[0 to 100 / 0 / 1% /step]
	<p>This SP displays the percent of toner remaining for each color. This SP allows the user to check the toner supply at any time.</p> <p>Note: This precise method of measuring remaining toner supply (1% steps) is better than other machines in the market that can only measure in increments of 10 (10% steps).</p> <p>This SP is expanded for color MFP and color LP machines. For this machine, the count is done for black only.</p>		

8811	Eco Counter (D158/D159)		
001	Eco Total	*CTL	[0 to 99999999 / 0 / 1]
	Displays the number of pages reduced by using the duplex and the combine function.		
004	Duplex	*CTL	[0 to 99999999 / 0 / 1]
	Displays the number of pages reduced by using the duplex function.		
005	Combine	*CTL	[0 to 99999999 / 0 / 1]
	Displays the number of pages reduced by using the combine function.		
008	Duplex(%)	*CTL	[0 to 100 / 0 / 1%]
	Displays the utilization ratio of the duplex function.		

009	Combine(%)	*CTL	[0 to 100 / 0 / 1%]
	Displays the utilization ratio of the duplex function.		
010	Paper Cut(%)	*CTL	[0 to 100 / 0 / 1%]
	Displays the paper reduction ratio.		
101	Eco Totalr>Last	*CTL	[0 to 99999999 / 0 / 1]
	-		
104	Duplex>Last	*CTL	[0 to 99999999 / 0 / 1]
	-		
105	Combine>Last	*CTL	[0 to 99999999 / 0 / 1]
	-		
108	Duplex(%):Last	*CTL	[0 to 100 / 0 / 1%]
	-		
109	Combine(%):Last	*CTL	[0 to 100 / 0 / 1%]
	-		
110	Paper Cut(%):Last	*CTL	[0 to 100 / 0 / 1%]
	-		

8851	Cvr Cnt:0-10% (D158/D159)		
	These SPs display the number of scanned sheets on which the coverage of black is from 0% to 10%.		
011	0 to 2%: BK	*ENG	[0 to 99999999 / 0 / 1]
021	3 to 4%: BK	*ENG	
031	5 to 7%: BK	*ENG	
041	8 to 10%: BK	*ENG	

8861	Cvr Cnt:11-20% (D158/D159)		
	These SPs display the number of scanned sheets on which the coverage of black is from 11% to 20%.		
001	BK	*ENG	[0 to 99999999 / 0 / 1]

8871	Cvr Cnt:21-30% (D158/D159)		
	These SPs display the number of scanned sheets on which the coverage of black is from 21% to 30%.		
001	BK	*ENG	[0 to 99999999 / 0 / 1]

8881	Cvr Cnt:31%- (D158/D159)		
	These SPs display the number of scanned sheets on which the coverage of black is 30% or higher.		
001	BK	*ENG	[0 to 99999999 / 0 / 1]

8891	Page/Toner Bottle (D158/D159)		
	These SPs display the amount of the remaining current toner for black.		
001	BK	*ENG	[0 to 99999999 / 0 / 1]

8901	Page/Toner_Prev1 (D158/D159)		
	These SPs display the amount of the remaining previous toner.		
001	BK	*ENG	Black toner [0 to 99999999 / 0 / 1]

8911	Page/Toner_Prev2 (D158/D159)		
	These SPs display the amount of the remaining 2nd previous toner.		
001	BK	*ENG	Black toner [0 to 99999999 / 0 / 1]

8921	Cvr Cnt/Total (D158/D159)		
	Displays the total coverage and total printout number for each color.		
001	Coverage (%) BK	*CTL	[0 to 2147483647 / 0 / 1%]
011	Coverage/P:BK	*CTL	[0 to 99999999 / 0 / 1]

8941	Machine Status (D158/ D159)	*CTL	[0 to 99999999 / 0 / 1]
	These SPs count the amount of time the machine spends in each operation mode. These SPs are useful for customers who need to investigate machine operation for improvement in their compliance with ISO Standards.		
001	Operation Time	Engine operation time. Does not include time while controller is saving data to HDD (while engine is not operating).	
002	Standby Time	Engine not operating. Includes time while controller saves data to HDD. Does not include time spent in Energy Save, Low Power, or Off modes.	
003	Energy Save Time	Includes time while the machine is performing background printing.	
004	Low Power Time	Includes time in Energy Save mode with Engine on. Includes time while machine is performing background printing.	
005	Off Mode Time	Includes time while machine is performing background printing. Does not include time machine remains powered off with the power switches.	
006	SC	Total time when SC errors have been staying.	
007	PrtJam	Total time when paper jams have been staying during printing.	
008	OrgJam	Total time when original jams have been staying during scanning.	
009	Supply PM Unit End	Total time when toner end has been staying	

8961	Electricity Status (D158/D159)		
	-		

001	Ctrl Standby Time	*CTL	[0 to 99999999 / 0 / 1]
002	STR Time	*CTL	
003	Main Power Off Time	*CTL	
004	Reading and Printing Time	*CTL	
005	Printing Time	*CTL	[0 to 99999999 / 0 / 1]
006	Reading Time	*CTL	
007	Eng Waiting Time	*CTL	
008	Low Power State Time	*CTL	
009	Silent State Time	*CTL	

8999	AdminCounter (D158/D159)		
	Display the total coverage and total printout number for each color.		
003	Copy: BW	-	[0 to 99999999 / 0 / 1]
007	Printer: BW	-	
010	Fax Print: BW	-	
012	A3/DLT	-	
013	Duplex	-	
023	Copy: BW (%)	-	
027	Printer: BW (%)	-	
030	Fax Print: BW (%)	-	[0 to 2147483647 / 0 / 1]
101	Transmission Total: Color	-	
102	Transmission Total: BW	-	
103	Fax Transmission	-	[0 to 99999999 / 0 / 1]
104	Scanner Transmission: Color	-	
103	Fax Transmission	-	[0 to 99999999 / 0 / 1]
104	Scanner Transmission: Color	-	[0 to 99999999 / 0 / 1]

105	Scanner Transmission: BW	-	[0 to 99999999 / 0 / 1]
-----	--------------------------	---	-------------------------

Input and Output Check

Input Check

5803	[Input Check] (D160/D161/D170)		
001	Safety SW	ENG	[0x00 to 0xFF / 0 / 1/step] 0:OFF 1:ON
002	Safety SW-LD5V	ENG	[0x00 to 0xFF / 0 / 1/step] 0:OFF 1:ON
003	Right Cover SW	ENG	[0x00 to 0xFF / 0 / 1/step] 0:CLOSE 1:OPEN
004	Right LowCover SW	ENG	[0x00 to 0xFF / 0 / 1/step] 0:CLOSE 1:OPEN
006	Upper Relay S	ENG	[0x00 to 0xFF / 0 / 1/step] 0:Not detected 1:Paper detected
007	Lower Relay S	ENG	[0x00 to 0xFF / 0 / 1/step] 0:Not detected 1:Paper detected
009	Regist Sensor	ENG	[0x00 to 0xFF / 0 / 1/step] 0:Not detected 1:Paper detected
010	Exit Sensor	ENG	[0x00 to 0xFF / 0 / 1/step] 0:Not detected 1:Paper detected

011	Duplex Inverter S	ENG	[0x00 to 0xFF / 0 / 1/step] 0:Not detected 1:Paper detected
012	Duplex Entrance S	ENG	[0x00 to 0xFF / 0 / 1/step] 0:Not detected 1:Paper detected
013	Duplex Exit S	ENG	[0x00 to 0xFF / 0 / 1/step] 0:Not detected 1:Paper detected
014	Bypass PE S	ENG	[0x00 to 0xFF / 0 / 1/step] 0:Not detected 1:Paper detected
015	Bypass P Size S	ENG	[0x00 to 0xFF / 0 / 1/step] Refer to *5
016	Upper PE S	ENG	[0x00 to 0xFF / 0 / 1/step] 0:Not detected 1:Paper detected
017	Lower PE S	ENG	[0x00 to 0xFF / 0 / 1/step] 0:Not detected 1:Paper detected
018	Upper P Size SW	ENG	[0x00 to 0xFF / 0 / 1/step] Refer to *5
019	Lower P Size SW	ENG	[0x00 to 0xFF / 0 / 1/step] Refer to *5
032	Main M Lock	ENG	[0x00 to 0xFF / 0 / 1/step] 0:Not locked 1:Locked
033	Polygon M Lock	ENG	[0x00 to 0xFF / 0 / 1/step] 0:Not locked 1:Locked

035	Total CO Install	ENG	[0x00 to 0xFF / 0 / 1/step] 0:Unconnected 1:Connected
036	Key CO Install	ENG	[0x00 to 0xFF / 0 / 1/step] 0:Unconnected 1:Connected
037	L-Synchronization	ENG	[0x00 to 0xFF / 0 / 1/step] 0:Undetected 1:Detected
045	Platen Cover S	ENG	[0x00 to 0xFF / 0 / 1/step] 0:CLOSE 1:OPEN
050	Fan Motor Lock	ENG	[0x00 to 0xFF / 0 / 1/step] 0:*6Lock 1:Unlocked
051	2 Tray BK Install	ENG	[0x00 to 0xFF / 0 / 1/step] 0:Not Connected 1:Connected
053	HP Sensor	ENG	[0x00 to 0xFF / 0 / 1/step] 0:Not Detected 1:Detected
054	Duplex Fan M Lock	ENG	[0x00 to 0xFF / 0 / 1/step] 0:*6Lock 1:Unlocked
055	Tray1: Tray Set	ENG	[0x00 to 0xFF / 0 / 1/step] 0:Unset 1:Set
056	Tray2: Tray Set	ENG	[0x00 to 0xFF / 0 / 1/step] 0:Unset 1:Set

057	Tray1: Paper Lift	ENG	[0x00 to 0xFF / 0 / 1/step] 0:Not Maximum 1:Maximum
058	Tray2: Paper Lift	ENG	[0x00 to 0xFF / 0 / 1/step] 0:Not Maximum 1:Maximum
059	Bypass: Length	ENG	[0x00 to 0xFF / 0 / 1/step] 0:Not Detected 1:Paper Detected
060	Bypass: HP	ENG	[0x00 to 0xFF / 0 / 1/step] 0:Not Lifted 1:Lifted
061	Key Card Install	ENG	[0x00 to 0xFF / 0 / 1/step] 0:Unconnected 1:Connected
071	Bank:CPU-Port2	ENG	[0x00 to 0xFF / 0 / 1/step] 0:*7 1:
072	Bank:CPU-Port3	ENG	[0x00 to 0xFF / 0 / 1/step] 0:*8 1:
073	Bank:CPU-PortA	ENG	[0x00 to 0xFF / 0 / 1/step] 0:*9 1:
074	Bank:CPU-PortB	ENG	[0x00 to 0xFF / 0 / 1/step] 0:*10 1:
080	ADF Lift Up	ENG	[0x00 to 0xFF / 0 / 1/step] 0:CLOSE 1:OPEN

081	ADF Feed Cover	ENG	[0x00 to 0xFF / 0 / 1/step] 0:CLOSE 1:OPEN
082	ADF Original Set	ENG	[0x00 to 0xFF / 0 / 1/step] 0:Not Detected 1:Paper Detected
083	ADF Registration	ENG	[0x00 to 0xFF / 0 / 1/step] 0:Not Detected 1:Paper Detected
084	ADF Exit Sensor	ENG	[0x00 to 0xFF / 0 / 1/step] 0:Not Detected 1:Paper Detected
085	ADF Rear Edge	ENG	[0x00 to 0xFF / 0 / 1/step] 0:No Paper Detected 1:Paper Detected
086	ADF Org Length1	ENG	[0x00 to 0xFF / 0 / 1/step] 0:* 11 1:
087	ADF Org Length2	ENG	[0x00 to 0xFF / 0 / 1/step] * 11
088	ADF Org Length3	ENG	[0x00 to 0xFF / 0 / 1/step] 0:* 11 1:
089	ADF Org Width1	ENG	[0x00 to 0xFF / 0 / 1/step] 0:* 11 1:
090	ADF Org Width2	ENG	[0x00 to 0xFF / 0 / 1/step] 0:* 11 1:

091	ADF Org Width3	ENG	[0x00 to 0xFF / 0 / 1/step] 0:* 11 1:
092	ADF Org Width4	ENG	[0x00 to 0xFF / 0 / 1/step] 0:* 11 1:
093	ADF Skew Correct	ENG	[0x00 to 0xFF / 0 / 1/step] 0:Not Detected 1:Paper Detected

*5 Size code for PFU (Paper feed unit) / By-pass tray

PFU	00	01	02	03	04	05	06	07
EU	LTT	B5T	HLTY	A3T	A4T	B5Y	A4Y	B4T
NA	LTT	B5T	A5Y	DLTT	A4T	Exe	LTY	LGT

By-pass Tray	00	01	02	03	04	05	06	07	08	09	0C	0D	10	11	18	19
EU	A5T	A5T	B5T	B5Y	B4Y	B4T	A5Y	A4T	A5T	A5T	A4Y	A3T	A5T	A5T	B6T	B6T
NA	HLTT	HLTT	LTS/LG	LTS/G	LY	DLT	LTS/LG	LTS/LG	HLTT	HLTT	LY	DLT	HLTT	HLTT	HLTT	HLTT

*6 Fan motor lock

Only available with High speed revolution.

(Can not refer with Low speed or Stop)

*7 Bank:CPU-Port2

Display CPU port infos "****" of [80 **H] from Bank with 8bit.

*8 Bank:CPU-Port3

Display CPU port infos "****" of [81 **H] from Bank with 8bit.

*9 Bank:CPU-PortA

Display CPU port infos "****" of [82 **H] from Bank with 8bit.

* 10 Bank:CPU-PortB

Display CPU port infos “***” of [83 ** H] from Bank with 8bit.

* 11 ADF: Combination of detect sensor for Org Length/ Org Width.

Size (W*L)	Width detect sensor				On table sensor		
	1	2	3	4	B5	A4	LG
A3 vertical (297*420)	YES	YES	YES	YES	YES	YES	YES
B4 vertical (257*364)	YES	YES	-	-	YES	YES	YES
A4 vertical (210/297)	YES	-	-	-	YES	YES	-
A4 landscape (297*210)	YES	YES	YES	YES	-	-	-
B5 vertical (182*257)	-	-	-	-	YES	-	-
B5 landscape (257*182)	YES	YES	-	-	-	-	-
A5 vertical (148*210)	-	-	-	-	-	-	-
A5 landscape (210*148)	YES	-	-	-	-	-	-
11"*17" (DLT) vertical	YES	YES	YES	-	YES	YES	YES
11"*15" vertical	YES	YES	YES	-	YES	YES	YES
10"*14" vertical	YES	YES	-	-	YES	YES	YES
8 1/2"*14"(LG) vertical	YES	-	-	-	YES	YES	YES
8 1/2"*13" (F4) *2 vertical	YES	-	-	-	YES	YES	YES
8 1/4"*13" vertical *	YES	-	-	-	YES	YES	YES
8"*13" (F) * Vertical	YES	-	-	-	YES	YES	YES
8 1/2"*11" (LT) vertical	YES	-	-	-	YES	-	-
11"*8 1/2" (LT) Landscape	YES	YES	YES	-	-	-	-

7 1/4" * 10 1/2" (US EXE) vertical	YES	-	-	-	YES	-	-
10 1/2" * 7 1/4" (US EXE) landscape	YES	YES	YES	-	-	-	-
8" * 10" vertical	YES	-	-	-	YES	-	-
5 1/2" * 8 1/2" (HLT) vertical	-	-	-	-	-	-	-
8 1/2" * 5 1/2" (HLT) landscape	YES	-	-	-	-	-	-
8K vertical (267*390)	YES	YES	YES	-	YES	YES	YES
16K vertical (195*267)	YES	-	-	-	YES	-	-
16K landscape(267*195)	YES	YES	YES	-	-	-	-

6007	[ADF INPUT Check] (D158/159)		
	Displays ADF sensor information.		
001	Original Length 1 (B5 Detection Sensor)	ENG	[0 or 1 / 0 / 1 / step] 0: No paper detected 1: Paper Detected
002	Original Length 2 (A4 Detection Sensor)	ENG	[0 or 1 / 0 / 1 / step] 0: No paper detected 1: Paper Detected
003	Original Length3 (LG Detection Sensor)	ENG	[0 or 1 / 0 / 1 / step] 0: No paper detected 1: Paper Detected
004	Original Width 1	ENG	[0 or 1 / 0 / 1 / step] 0: No paper detected 1: Paper Detected

005	Original Width 2	ENG	[0 or 1 / 0 / 1 / step] 0: No paper detected 1: Paper Detected
006	Original Width 3	ENG	[0 or 1 / 0 / 1 / step] 0: No paper detected 1: Paper Detected
007	Original Width 4	ENG	[0 or 1 / 0 / 1 / step] 0: No paper detected 1: Paper Detected
008	Original Width 5	ENG	[0 or 1 / 0 / 1 / step] 0: No paper detected 1: Paper Detected
009	Original Detection	ENG	[0 or 1 / 0 / 1 / step] 0: No paper detected 1: Paper Detected
011	Skew Correction	ENG	[0 or 1 / 0 / 1 / step] 0: No paper detected 1: Paper Detected
013	Registration Sensor	ENG	[0 or 1 / 0 / 1 / step] 0: No paper detected 1: Paper Detected
014	Exit Sensor	ENG	[0 or 1 / 0 / 1 / step] 0: No paper detected 1: Paper Detected
015	Feed Cover Sensor	ENG	[0 or 1 / 0 / 1 / step] 0: Close 1: Open
016	Lift Up Sensor	ENG	[0 or 1 / 0 / 1 / step] 0: Not lifted 1: Lifted

023	Rear Edge Detection	ENG	[0 or 1 / 0 / 1 / step] 0: No paper detected 1: Paper Detected
-----	---------------------	-----	--

6154	[INPUT Check] (D158/159)		
001	1 bin:Set Detection	ENG	[0 or 1 / 0 / 1 / step]
003	1BIN: Paper Remain	ENG	[0 or 1 / 0 / 1 / step]
004	1BIN: Cover Open	ENG	[0 or 1 / 0 / 1 / step]

Output Check

5804	[OUTPUT Check] (D158/D159)		
001	Main Motor: CW: High	ENG	[0 or 1 / 0 / 1/step]
002	Main Motor: CW: Low	ENG	[0 or 1 / 0 / 1/step]
003	Main Motor: CCW: High	ENG	[0 or 1 / 0 / 1/step]
004	Main Motor: CCW: Low	ENG	[0 or 1 / 0 / 1/step]
005	Duplex Motor: HOLD	ENG	[0 or 1 / 0 / 1/step]
006	Duplex Motor: CCW: 582.4	ENG	[0 or 1 / 0 / 1/step]
007	Duplex Motor: CCW: 636.6	ENG	[0 or 1 / 0 / 1/step]
008	Duplex Motor: CCW: 708.5	ENG	[0 or 1 / 0 / 1/step]
009	Duplex Motor: CCW: 774.8	ENG	[0 or 1 / 0 / 1/step]
010	Interchange Motor: HOLD	ENG	[0 or 1 / 0 / 1/step]
011	Interchange Motor: CW:430.1	ENG	[0 or 1 / 0 / 1/step]
012	Interchange Motor: CW:524.5	ENG	[0 or 1 / 0 / 1/step]
013	Interchange Motor: CCW: 430.1	ENG	[0 or 1 / 0 / 1/step]
014	Interchange Motor: CCW: 474.3	ENG	[0 or 1 / 0 / 1/step]

015	Interchange Motor: CCW: 524.5	ENG	[0 or 1 / 0 / 1/step]
016	Interchange Motor: CCW: 577.3	ENG	[0 or 1 / 0 / 1/step]
020	Toner Bottle Motor	ENG	[0 or 1 / 0 / 1/step]
021	1st Tray Up	ENG	[0 or 1 / 0 / 1/step]
022	1st Tray Down	ENG	[0 or 1 / 0 / 1/step]
023	2nd Tray Up	ENG	[0 or 1 / 0 / 1/step]
024	2nd Tray Down	ENG	[0 or 1 / 0 / 1/step]
025	Exhaust Fan Motor: High	ENG	[0 or 1 / 0 / 1/step]
026	Exhaust Fan Motor: Low	ENG	[0 or 1 / 1 / 1/step]
027	Duplex Fan	ENG	[0 or 1 / 0 / 1/step]
032	Registration CL	ENG	[0 or 1 / 0 / 1/step]
033	1st Paper Feed CL	ENG	[0 or 1 / 0 / 1/step]
034	2nd Paper Feed CL	ENG	[0 or 1 / 0 / 1/step]
035	Paper Tranort CL1	ENG	[0 or 1 / 0 / 1/step]
039	Interchange SOL	ENG	[0 or 1 / 0 / 1/step]
040	Fusing SOL	ENG	[0 or 1 / 0 / 1/step]
041	Dehumidification Heater	ENG	[0 or 1 / 0 / 1/step]
042	PP:Image Transfer: -	ENG	[0 or 1 / 0 / 1/step]
043	PP:Image Transfer: +	ENG	[0 or 1 / 0 / 1/step]
044	Separation Voltage	ENG	[0 or 1 / 0 / 1/step]
045	PP:Development	ENG	[0 or 1 / 0 / 1/step] 0:OFF, 1:ON
046	PP:Charge	ENG	[0 or 1 / 0 / 1/step]
047	P Sensor	ENG	[0 or 1 / 0 / 1/step]

048	Anti-static LED	ENG	[0 or 1 / 0 / 1/step] 0:OFF, 1:ON
049	Polygon Motor: High	ENG	[0 or 1 / 0 / 1/step] 0:OFF, 1:ON
050	Polygon Motor: Low	ENG	[0 or 1 / 0 / 1/step] 0:OFF, 1:ON
051	LD On	ENG	[0 or 1 / 0 / 1/step] 0:OFF, 1:ON
055	By-pass CL	ENG	[0 or 1 / 0 / 1/step] 0:OFF, 1:ON
056	By-pass Tray CL	ENG	[0 or 1 / 0 / 1/step] 0:OFF, 1:ON
071	Bank: Motor	ENG	[0 or 1 / 0 / 1/step]
072	Bank: Feed Clutch 1	ENG	[0 or 1 / 0 / 1/step] 0:OFF, 1:ON
073	Bank: Feed Clutch2	ENG	[0 or 1 / 0 / 1/step] 0:OFF, 1:ON
074	Bank:Trans Clutch	ENG	[0 or 1 / 0 / 1/step]
202	Scanner Lamp	ENG	[0 or 1 / 0 / 1/step]

5804	[OUTPUT Check] (D160/D161/D170)		
001	Main M-Fwd	ENG	[0 or 1 / 0 / 1 / step]
002	Main M-Rev	ENG	[0 or 1 / 0 / 1 / step]
003	Quenching Lamp	ENG	[0 or 1 / 0 / 1 / step]
004	Toner Sup M-Fwd	ENG	[0 or 1 / 0 / 1 / step]
005	Fan M-High	ENG	[0 or 1 / 0 / 1 / step]
006	Fan M-Low	ENG	[0 or 1 / 0 / 1 / step]
007	Registration CL	ENG	[0 or 1 / 0 / 1 / step]

008	Bypass Feed CL	ENG	[0 or 1 / 0 / 1 / step]
009	Upper Feed CL	ENG	[0 or 1 / 0 / 1 / step]
010	Lower Feed CL	ENG	[0 or 1 / 0 / 1 / step]
011	BK-Low Lift M-Up	ENG	[0 or 1 / 0 / 1 / step]
012	BK-Low Lift M-Dw	ENG	[0 or 1 / 0 / 1 / step]
013	Relay CL	ENG	[0 or 1 / 0 / 1 / step]
014	BK-Relay CL	ENG	[0 or 1 / 0 / 1 / step]
015	BK-Upper Feed CL	ENG	[0 or 1 / 0 / 1 / step]
016	BK-Lower Feed CL	ENG	[0 or 1 / 0 / 1 / step]
017	BK-Lift M	ENG	[0 or 1 / 0 / 1 / step]
018	BK-Up Lift M-Up	ENG	[0 or 1 / 0 / 1 / step]
019	BK-Up Lift M-Dw	ENG	[0 or 1 / 0 / 1 / step]
020	Duplex Inv M-Rev	ENG	[0 or 1 / 0 / 1 / step]
021	Duplex Inv M-Fwd	ENG	[0 or 1 / 0 / 1 / step]
022	Duplex Trans M	ENG	[0 or 1 / 0 / 1 / step]
023	Duplex Gate SOL	ENG	[0 or 1 / 0 / 1 / step]
024	Duplex Inv M-Hold	ENG	[0 or 1 / 0 / 1 / step]
025	Dup Trans M-Hold	ENG	[0 or 1 / 0 / 1 / step]
026	Polygon M	ENG	[0 or 1 / 0 / 1 / step]
027	Polygon M/LD	ENG	[0 or 1 / 0 / 1 / step]
038	Fusing SOL	ENG	[0 or 1 / 0 / 1 / step]
040	Duplex Fan M-High	ENG	[0 or 1 / 0 / 1 / step]
041	Duplex Fan M-Low	ENG	[0 or 1 / 0 / 1 / step]
042	1st Tray Up	ENG	[0 or 1 / 0 / 1 / step]
043	1st Tray Down	ENG	[0 or 1 / 0 / 1 / step]
044	2nd Tray Up	ENG	[0 or 1 / 0 / 1 / step]

045	2nd Tray Down	ENG	[0 or 1 / 0 / 1 / step]
046	Bypass Tray CL	ENG	[0 or 1 / 0 / 1 / step]
071	Bank:Motor	ENG	[0 or 1 / 0 / 1 / step]
072	Bank:Feed Clutch1	ENG	[0 or 1 / 0 / 1 / step]
073	Bank:Feed Clutch2	ENG	[0 or 1 / 0 / 1 / step]
074	Bank:Trans Clutch	ENG	[0 or 1 / 0 / 1 / step]
080	ADF Feed Motor F	ENG	[0 or 1 / 0 / 1 / step]
081	ADF Relay Motor F	ENG	[0 or 1 / 0 / 1 / step]
082	ADF Feed Clutch	ENG	[0 or 1 / 0 / 1 / step]
083	ADF Inverter Sol	ENG	[0 or 1 / 0 / 1 / step]
084	ADF Feed Motor R	ENG	[0 or 1 / 0 / 1 / step]
085	ADF Relay Motor R	ENG	[0 or 1 / 0 / 1 / step]
086	ADF Feed Solenoid	ENG	[0 or 1 / 0 / 1 / step]
087	ADF Stamp	ENG	[0 or 1 / 0 / 1 / step]
202	Scanner Light:C	ENG	[0 or 1 / 0 / 1 / step]
203	Scanner Light:BW	ENG	[0 or 1 / 0 / 1 / step]

6008	[ADF OUTPUT Check] (D158/159)		
	-		
003	Feed Motor Forward	ENG	[0 or 1 / 0 / 1 / step] 0:Off 1:On
	Rotates the paper feed motor to check the operation of ADF.		
004	Feed Motor Reverse	ENG	[0 or 1 / 0 / 1 / step] 0:Off 1:On
	Reverses the paper feed motor to check the operation of the load on the ADF.		

005	Relay Motor Forward	ENG	[0 or 1 / 0 / 1 / step] 0:Off 1:On
	Rotates the relay motor to check the operation of ADF.		
006	Relay Motor Reverse	ENG	[0 or 1 / 0 / 1 / step] 0:Off 1:On
	Reverse the relay motor to check the operation of ADF.		
011	Inverter Solenoid	ENG	[0 or 1 / 0 / 1 / step] 0:Off 1:On
	Drives the inverter Solenoid to check the operation of ADF.		
012	Stamp	ENG	[0 or 1 / 0 / 1 / step] 0:Off 1:On
	Drives the stamp to check the operation of ADF.		
013	Fan Motor	ENG	[0 or 1 / 0 / 1 / step] 0:Off 1:On
	Drives the fan motor to check the operation of ADF.		
014	Feed Clutch	ENG	[0 or 1 / 0 / 1 / step] 0:Off 1:On
	Drives the paper feed clutch to checks the operation of ADF.		
015	Feed Solenoid	ENG	[0 or 1 / 0 / 1 / step] 0:Off 1:On
	Drives the paper feed solenoid to check the operation of ADF.		

6155	[OUTPUT Check] (D158/159)		
002	1BIN SOL	ENG	[0 or 1 / 1 / 1 / step]
	Drives the 1 bin solenoid to check the operation. Turns off automatically in 10 seconds after turned on.		
003	1BIN Motor: HOLD	ENG	[0 or 1 / 1 / 1 / step]
	Rotates the 1 bin motor to check the operation. Turns off automatically in 10 seconds after turned on.		
004	1BIN Motor: CW:High	ENG	[0 or 1 / 1 / 1 / step]
	Turns on after holding 50ms.		
005	1BIN Motor: CW:Low	ENG	[0 or 1 / 1 / 1 / step]
	Turns on after holding 50ms.		

Printer SP Tables

SP1-XXX (Service Mode)

D158/D159

3

1001	[Bit Switch]			
001	Bit Switch 1		0	1
	bit 0	Not Used	-	-
	bit 1	Not Used	-	-
	bit 2	Not Used	-	-
	bit 3	No I/O Timeout	Disabled	Enabled
		Enables/Disables MFP I/O Timeouts. If enabled, the MFP I/O Timeout setting will have no affect. I/O Timeouts will never occur.		
	bit 4	SD Card Save Mode	Disabled	Enabled
		If this bit switch is enabled, print jobs will be saved to the GW SD slot and not output to paper.		
	bit 5	Not Used	-	-
	bit 6	Not Used	-	-
bit 7	[RPCS,PCL]: Printable area frame border	Disabled	Enabled	
	Prints all RPCS and PCL jobs with a border around the printable area.			
1001	[Bit Switch]			

002	Bit Switch 2		0	1
	bit 0	Not Used	-	-
	bit 1	Not Used	-	-
	bit 2	Applying a Collate Type	Shift Collate	Normal Collate
	A collate type (shift or normal) will be applied to all jobs that do not explicitly define a collate type. Note: If #5-0 is enabled, this BitSwitch has no effect.			
	bit 3	[PCL5e/c,PS]: PDL Auto Switching	Enabled	Disabled
	bit 4	Not Used	-	-
	bit 5	Not Used	-	-
	bit 6	DFU	-	-
	bit 7	Not Used	-	-

1001	[Bit Switch]			
003	Bit Switch 3		0	1
	bit 0	DFU	-	-
	bit 1	DFU	-	-
	bit 2	[PCL5e/c]: Legacy HP compatibility	Disabled	Enabled
	Uses the same left margin as older HP models such as HP4000/HP8000. In other words, the left margin defined in the job (usually "<ESC>*r0A") will be changed to "<ESC>*r1A".			
	bit 3	Not Used	-	-
	bit 4	DFU	-	-
	bit 5	DFU	-	-
	bit 6	DFU	-	-
	bit 7	Not Used	-	-

1001	[Bit Switch]			
004	Bit Switch 4	0	1	
	bit 0	DFU	-	-
	bit 1	DFU	-	-
	bit 2	DFU	-	-
	bit 3	DFU	-	-
	bit 4	DFU	-	-
	bit 5	DFU	-	-
	bit 6	DFU	-	-
	bit 7	DFU	-	-

1001	[Bit Switch]			
005	Bit Switch 5	0	1	
		Show "Collate Type", "Staple Type" and "Punch Type" buttons on the operation panel.	Disabled	Enabled
	bit 0	<p>If enabled, users will be able to configure a Collate Type, Staple Type, and Punch Type from the operation panel. The available Types will depend on the device and configured options.</p> <p>After enabling this BitSw, the settings will appear under: "User Tools > Printer Features > System"</p>		
	bit 1	Multiple copies if a paper size or type mismatch occurs	Disabled (single copy)	Enabled (multiple)
	<p>If a paper size or type mismatch occurs during the printing of multiple copies, only a single copy is output by default. Using this BitSw, the device can be configured to print all copies even if a paper mismatch occurs.</p>			

bit 2	Prevent SDK applications from altering the contents of a job.	Disabled	Enabled
	<p>If this BitSw is enabled, SDK applications will not be able to alter print data. This is achieved by preventing SDK applications from accessing a module called the "GPS Filter".</p> <p>Note: The main purpose of this BitSw is for troubleshooting the effects of SDK applications on data.</p>		
bit 3	[PS] PS Criteria	Pattern 3 (2 to 4): The larger the pattern number, the greater the number of criterion used. Pattern 4 includes most PS commands	Pattern 1: A small number of PS tags and headers
	Change the number of PS criterion used by the PS interpreter to determine whether a job is PS data or not.		
bit 4	Increase max number of the stored jobs.	Disabled (100)	Enabled (750)
	Changes the maximum number of jobs that can be stored on the HDD. The default (disabled) is 100. If this is enabled, the max. will be raised to 750.		
bit 5	DFU	-	-
bit 6	Method for determining the image rotation for the edge to bind on.	Disabled	Enabled
	<p>If enabled, the image rotation will be performed as they were in the specifications of older models for the binding of pages of mixed orientation jobs.</p> <p>The old models are below:</p> <ul style="list-style-type: none"> - PCL: Pre-04A models - PS/PDF/RPCS:Pre-05S models 		

	bit 7	Letterhead mode printing	Disabled	Enabled (Duplex)
	<p>Routes all pages through the duplex unit.</p> <p>If this is disabled, simplex pages or the last page of an odd-paged duplex job, are not routed through the duplex unit. This could result in problems with letterhead/pre-printed pages.</p> <p>Only affects pages specified as Letterhead paper.</p>			

1001	[Bit Switch]			
006	Bit Switch 6		0	1
	bit 0	DFU	-	-
	bit 1	Not used	-	-
	bit 2	Not used	-	-
	bit 3	Not used	-	-
	bit 4	Not used	-	-
	bit 5	Not used	-	-
	bit 6	DFU	-	-
	bit 7	Not used	-	-

1001	[Bit Switch]		
-------------	---------------------	--	--

007	Bit Switch 7		0	1
		Print path	Disabled	Enabled
	bit 0	If enabled, simplex pages (in mixed simplex/duplex PS/PCL5 jobs only) and the last page of an odd paged duplex job (PS, PCL5, PCL6), are always routed through the duplex unit. Not having to switch paper paths increases the print speed slightly.		
	bit 1	Not Used	-	-
	bit 2	Not Used	-	-
	bit 3	DFU	-	-
	bit 4	DFU	-	-
	bit 5	Not Used	-	-
	bit 6	Not Used	-	-
bit 7	DFU	-	-	

1001	[Bit Switch]			
008	Bit Switch 8		0	1
	bit 0	Not Used	-	-
	bit 1	Not Used	-	-
	bit 2	Not Used	-	-
	bit 3	DFU	-	-
	bit 4	Not Used	-	-
	bit 5	Not Used	-	-
	bit 6	Not Used	-	-
	bit 7	RTIFF(TIFFDP): Switches the rotation angle of the image	Disabled	Enabled

1001	[Bit Switch]		
-------------	---------------------	--	--

009	Bit Switch 9		0	1
	bit 0	PDL Auto Detection timeout of jobs submitted via USB or Parallel Port (IEEE 1284).	Disabled (Immediately)	Enabled (10 seconds)
To be used if PDL auto-detection fails. A failure of PDL autodetection doesn't necessarily mean that the job can't be printed. This bit switch tells the device whether to time-out immediately (default) upon failure or to wait 10 seconds.				
	bit 1	DFU	-	-
	bit 2	Job Cancel	Disabled (Not cancelled)	Enabled (Cancelled)
If this bit switch is enabled, all jobs will be cancelled after a jam occurs. Note: If this bit switch is enabled, printing under the following conditions might result in problems: - Job submission via USB or Parallel Port - Spool printing (WIM > Configuration > Device Settings > System)				
	bit 3	PCL/PS bypass tray paper rotation (SEF/LEF)	Disabled	Enabled
	This bit switch causes the device to revert to the behavior of previous generations. It only takes effect if "Bypass Tray Setting Priority" = "Driver/Command". Previous spec (bit switch=1): If a standard sized paper mismatch occurred in the bypass tray, the MFP always prompted for SEF paper. If this bit switch=0 (default) then in the event of a standard sized paper mismatch, the MFP will always prompt for paper of the rotation (SEF/LEF) determined by the MFP bypass tray paper setting or by the bypass tray sensor.			
	bit 4	Timing of the PDL Status ReadBack (JOB END) when printing multiple collated copies.	Disabled	Enabled
	This bit switch determines the timing of the PDL USTATUS JOB END sent when multiple collated copies are being printed. 0 (default): JOB END is sent by the device to the client after the first copy has completed printing. This causes the page counter to be incremented after the first copy and then again at the end of the job. 1: JOB END is sent by the device to the client after the last copy has finished printing. This causes the page counter to be incremented at the end of each job.			

	bit 5	Display UTF-8 text in the operation panel	Enabled	Disabled
	<p>Enabled (=0): Text composed of UTF-8 characters can be displayed in the operation panel.</p> <p>Disabled (=1): UTF-8 characters cannot be displayed in the operation panel.</p> <p>For example, job names are sometimes stored in the MIB using UTF-8 encoded characters. When these are displayed on the operation panel, they will be garbled unless this BitSw is enabled (=0).</p>			
	bit 6	DFU	-	-
	bit 7	Enable/Disable Print from USB/SD's Preview function	Enabled	Disabled
	<p>Determines whether Print from USB/SD will have the Preview function.</p> <p>Enabled (=0): Print from USB/SD will have the Preview function.</p> <p>Disabled (=1): Print from USB/SD will not have the Preview function.</p>			

1001	[Bit Switch]			
010	Bit Switch A		0	1
	bit 0	DFU	-	-
	bit 1	DFU	-	-
	bit 2	DFU	-	-
	bit 3	DFU	-	-
	bit 4	Not Used	-	-
	bit 5	Auto Job Promotion locks the queue	Queue is not locked after AJP	Queue locked after AJP
	<p>If this is 1, then after a job is stored using Auto Job Promotion, new jobs cannot be added to the queue until the stored job has been completely printed.</p>			

	bit 6	Allow use of Auto Job Promotion if connected to an external charge device.	Does not allow AJP with ECD	Allows AJP with ECD
	If this is 0, Auto Job Promotion will be automatically disabled if an external charge device is connected. Note: We do not officially support enabling this switch (1). Use it at your own risk.			
	bit 7	DFU	-	-

1001	[Bit Switch]			
011	Bit Switch B		0	1
	bit 0	DFU	-	-
	bit 1	DFU	-	-
	bit 2	Not Used	-	-
	bit 3	Not Used	-	-
	bit 4	Not Used	-	-
	bit 5	Not Used	-	-
	bit 6	Not Used	-	-
	bit 7	Not Used	-	-

1001	[Bit Switch]			
-------------	---------------------	--	--	--

012	Bit Switch C		0	1
	bit 0	DFU	-	-
	bit 1	Not Used	-	-
	bit 2	Not Used	-	-
	bit 3	Not Used	-	-
	bit 4	Not Used	-	-
	bit 5	Not Used	-	-
	bit 6	Not Used	-	-
	bit 7	Not Used	-	-

1003	[Clear Setting]		
001	Initialize System	*CTL	[- / - / -] [Execute]
	Initializes settings in the "System" menu of the user mode.		
003	Delete Program	*CTL	[- / - / -] [Execute]

1004	[Print Summary]		
Prints the service summary sheet (a summary of all the controller settings).			
001	Service Summary	CTL	[- / - / -] [Execute]
002	Service Summary 2	CTL	[- / - / -] [Execute]

1005	[Display Version]		
001	Printer Version	CTL	[- / - / -]
	Displays the version of the controller firmware.		

1006	[Sample / Proof Print]		
001	-	*CTL	[0 or 1 / 0 / 1 / step]
	-		

1110	[Media Print Device Setting]		
	Selects the setting for the media print device.		
002	0: Disable 1: Enable	*CTL	[0 or 1 / 1 / 1 / step]

1111	[All Job Delete Mode]		
001	-	*CTL	[0 or 1 / 0 / 1 / step] 0: Excluding New Job 1: Including New Job
	Selects whether to include an image processing job in jobs subject to full cancellation from the SCS job list.		

7910	[PDL]		
-------------	--------------	--	--

	-	CTL	[- / NULL / -]
001	RPCS 150 PS 151 RPDL 152 R98 153 R16 154 RPGL 155 R55 156 RTIFF 157 PCL 158 PCLXL 159 MSIS 160 MSIS(OPT) 161 PDF 162 BMLinks 163 PICTBRIDGE 164 PJI 165 IPDS 166 MediaPrint:JPEG 167 MediaPrint:TIFF 168 FONT 180 FONT1 181 FONT2 182 FONT3 183 FONT4 184 FONT5 185		

7911

[PDL Version]

	-	CTL	[- / NULL / -]
001	RPCS 150 PS 151 RPDL 152 R98 153 R16 154 RPGL 155 R55 156 RTIFF 157 PCL 158 PCLXL 159 MSIS 160 MSIS(OPT) 161 PDF 162 BMLinkS 163 PICTBRIDGE 164 PJI 165 IPDS 166 MediaPrint:JPEG 167 MediaPrint:TIFF 168 FONT 180 FONT1 181 FONT2 182 FONT3 183 FONT4 184 FONT5 185		

Scanner SP Tables

SP1-XXX (System and Others)

D158/159

1001	[Scan Nv Version]		
	Displays the version of the scanner NV.		
005	-	*CTL	[- / - / -]
1005	[Erase Margin(Remote scan)]		
	Creates an erase margin for all edges of the scanned image. If the machine has scanned the edge of the original, create a margin. This SP is activated only when the machine uses TWAIN scanning.		
001	Range from 0 to 5 mm	*CTL	[0 to 5 / 0 / 1 mm / step]
1009	[Remote scan disable]	*CTL	[0 or 1 / 0 / 1 / step] 0: enable, 1: disable
001	Enable or disable remote scan.		
1010	[Non Display Clear Light PDF]	*CTL	[0 or 1 / 0 / 1 / step] 0: Display, 1: No display
001	Display or Nondisplay remote scan.		
1011	[Org Count Disp]	*CTL	[0 or 1 / 0 / 1 / step] 0:OFF, 1: ON
001	This SP codes switches the original count display on/off.		
1012	[User Info Release]	*CTL	[0 or 1 / 1 / 1 / step] 0: No, 1: Yes

001	<p>This SP code sets the machine to release or not release the following items at job end.</p> <ul style="list-style-type: none"> • Destination (E-mail/Folder/CS) • Sender name • Mail Text • Subject line • File name
-----	--

1013	[Scan to Media Device Setting]	*CTL	[0 or 1 / 1 / 1 / step] 0:OFF, 1:ON
002	<p>This SP code enables/disables the multi-media function option (USB 2.0/SD Slot) mounted on the front of the machine. Operators can scan documents to either an SD card or a USB memory device inserted into this unit. This SP must be enabled (set to "1") in order for the device to function.</p>		

1015	[Time Stamp to File Name]	*CTL	[0 or 1 / 1 / 1 / step] 0: Disable, 1: Enable
001	<p>This SP code enables/disables to give a file name consisting of time and date of scanning when sending scanned file by E-mail, or sending to a folder.</p>		

SP2-XXX (Scanning-image quality)

D158/D159

2021	[Compression Level (Gray-scale)]		
	<p>Selects the compression ratio for grayscale processing mode (JPEG) for the five settings that can be selected at the operation panel.</p>		
001	Comp1:5-95	*CTL	[5 to 95 / 20 / 1 / step]
002	Comp2:5-95		[5 to 95 / 40 / 1 / step]
003	Comp3:5-95		[5 to 95 / 65 / 1 / step]
004	Comp4:5-95		[5 to 95 / 80 / 1 / step]
005	Comp5:5-95		[5 to 95 / 95 / 1 / step]

2024	[Compression ratio of ClearLight PDF]		
	Selects the compression ratio for clearlight PDF for the two settings that can be selected at the operation panel.		
001	Compression Ratio (Normal image)	*CTL	[5 to 95 / 25 / 1 / step]
002	Compression Ratio (High)		[5 to 95 / 20 / 1 / step]

2025	[Compression ratio of ClearLightPDF JPEG2000]		
	Selects the compression ratio for clearlight PDF for the two settings that can be selected at the operation panel.		
001	Compression Ratio (Normal) JPEG2000	*CTL	[5 to 95 / 25 / 1 / step]
002	Compression Ratio (High) JPEG2000		[5 to 95 / 20 / 1 / step]

Test Pattern Printing

D158/D159

Printing Test pattern: SP2-109

Some of these test patterns are used for copy image adjustments but most are used primarily for design testing.

3

Note

- Do not operate the machine until the test pattern is printed out completely. Otherwise, an SC occurs.
1. Enter the SP mode and select **SP2-109-001**.
 2. Enter the number for the test pattern that you want to print and press [#].
 3. When you want to change the density of printing a test pattern, select the density with SP2-109-002.
 4. When you are prompted to confirm your selection, touch "Yes" to select the test pattern for printing.
 5. Touch "Copy Window" to open the copy window, then select the settings for the test print (paper size etc.).
 6. Press the "Start" key to start the test print.
 7. After checking the test pattern, touch "SP Mode" on the LCD to return to the SP mode display.
 8. Reset all settings to the default values.
 9. Touch "Exit" twice to exit SP mode.

No.	Pattern	No.	Pattern
0	(No print)	10	Trimming Area
1	Vertical Lines (Single Dot)	11	Argyle Pattern (Single Dot)
2	Horizontal Lines (Single Dot)	12	Grayscales (Horizontal)
3	Vertical Lines (Double Dot)	13	Grayscales (Vertical)
4	Horizontal Lines (Double Dot)	14	Grayscales (Vertical/Horizontal)
5	Grid Pattern (Single Dot)	15	Grayscales (Vertical/Horizontal Overlay)
6	Grid Pattern (Double Dot)	16	Grayscales With White Lines (Horizontal)

7	Alternating Dot Pattern	17	Grayscales with White Lines (Vertical)
8	Isolated one dot	18	Grayscales with White Lines (Vertical/Horizontal)
9	Black Band (Horizontal)	-	-

D160/D161/D170

Printing Test pattern: SP5-902

Some of these test patterns are used for copy image adjustments but most are used primarily for design testing.

↓ Note

- Do not operate the machine until the test pattern is printed out completely. Otherwise, an SC occurs.
1. Enter the SP mode and select **SP5-902-001**.
 2. Enter the number for the test pattern that you want to print and press [#].
 3. When you are prompted to confirm your selection, touch "Yes" to select the test pattern for printing.
 4. Touch "Copy Window" to open the copy window, then select the settings for the test print (paper size etc.).
 5. Press the "Start" key to start the test print.
 6. After checking the test pattern, touch "SP Mode" on the LCD to return to the SP mode display.
 7. Reset all settings to the default values.
 8. Touch "Exit" twice to exit SP mode.

No.	Pattern	No.	Pattern
0	None	11	Independent Pattern (1 dot)
1	Vertical Line (1 dot)	12	Independent Pattern (2dot)
2	Vertical Line (2dot)	13	Independent Pattern (4dot)
3	Horizontal Line (1 dot)	14	Trimming Area
4	Horizontal Line (2dot)	15	Black Band (Horizontal)
5	Grid Vertical Line	16	Black Band (Vertical)
6	Grid Horizontal Line	17	Checker Flag Pattern

7	Grid Pattern Small	18	Grayscale (Vertical)
8	Grid Pattern Large	19	Grayscale (Horizontal)
9	Argyle Pattern Small	20	Full Dot Pattern
10	Argyle Pattern Large	21	All White Pattern

MEMO

MEMO