



**RICOH UNIVERSITY**

Learning ♦ Knowledge ♦ Performance



**M132**  
**SERVICE MANUAL**

**LANIER RICOH SAVIN**

It is the reader's responsibility when discussing the information contained within this document to maintain a level of confidentiality that is in the best interest of Ricoh Americas Corporation and its member companies.

***NO PART OF THIS DOCUMENT MAY BE REPRODUCED IN ANY FASHION AND DISTRIBUTED WITHOUT THE PRIOR PERMISSION OF RICOH AMERICAS CORPORATION.***

All product names, domain names or product illustrations, including desktop images, used in this document are trademarks, registered trademarks or the property of their respective companies.

They are used throughout this book in an informational or editorial fashion only and for the benefit of such companies. No such use, or the use of any trade name, or web site is intended to convey endorsement or other affiliation with Ricoh products.

## **WARNING**

*The Service Manual contains information regarding service techniques, procedures, processes and spare parts of office equipment distributed by Ricoh Americas Corporation. Users of this manual should be either service trained or certified by successfully completing a Ricoh Technical Training Program.*

*Untrained and uncertified users utilizing information contained in this service manual to repair or modify Ricoh equipment risk personal injury, damage to property or loss of warranty protection.*

*Ricoh Americas Corporation*

# LEGEND

PRODUCT CODE	COMPANY		
	LANIER	RICOH	SAVIN
M132	SP 8300DN	Aficio SP 8300DN	SP 8300DN

# DOCUMENTATION HISTORY

REV. NO.	DATE	COMMENTS
*	10/2012	Original Printing



# M132 SERVICE MANUAL

## TABLE OF CONTENTS

<b>1. PRODUCT INFORMATION.....</b>	<b>1-1</b>
1.1 SPECIFICATIONS.....	1-1
1.2 MACHINE CONFIGURATION.....	1-2
1.2.1 PRINTER.....	1-2
1.3 GUIDANCE FOR THOSE WHO ARE FAMILIAR WITH PREDECESSOR PRODUCTS.....	1-4
1.4 OVERVIEW.....	1-5
1.4.1 COMPONENT LAYOUT.....	1-5
1.4.2 PAPER PATH.....	1-7
1.4.3 DRIVE LAYOUT.....	1-8
<b>2. INSTALLATION.....</b>	<b>2-1</b>
2.1 INSTALLATION REQUIREMENTS.....	2-1
2.1.1 ENVIRONMENT.....	2-1
2.1.2 MACHINE LEVEL.....	2-2
2.1.3 MINIMUM SPACE REQUIREMENTS.....	2-3
2.1.4 POWER REQUIREMENTS.....	2-4
2.2 MAIN MACHINE INSTALLATION.....	2-5
2.2.1 INSTALLATION OVERVIEW.....	2-5
2.2.2 POWER SOCKET FOR PERIPHERAL.....	2-6
2.2.3 INSTALLATION FLOW CHART.....	2-7
2.2.4 MOVING THE MACHINE.....	2-7
2.2.5 TRANSPORTING THE MACHINE.....	2-7
2.3 1200-SHEET LCT INSTALLATION (D631).....	2-8
2.3.1 COMPONENT CHECK.....	2-8
2.3.2 INSTALLATION PROCEDURE.....	2-9
2.3.3 SIDE FENCE POSITION CHANGE.....	2-11
2.4 BRIDGE UNIT INSTALLATION (D634).....	2-12
2.4.1 COMPONENT CHECK.....	2-12
2.4.2 INSTALLATION PROCEDURE.....	2-13
2.5 1000-SHEET FINISHER (D588).....	2-17
2.5.1 ACCESSORY CHECK.....	2-17
2.5.2 INSTALLATION PROCEDURE.....	2-18

2.6	3000-SHEET FINISHER (D636)	2-21
2.6.1	ACCESSORY CHECK	2-21
2.6.2	INSTALLATION PROCEDURE	2-22
	Support Tray Installation	2-25
2.7	PUNCH UNIT INSTALLATION (D570)	2-26
2.7.1	COMPONENT CHECK	2-26
2.7.2	INSTALLATION PROCEDURE	2-27
2.8	OUTPUT JOGGER UNIT INSTALLATION (B703)	2-31
2.8.1	ACCESSORY CHECK LIST	2-31
2.8.2	INSTALLATION PROCEDURE	2-31
2.9	TRAY HEATER	2-33
2.9.1	INSTALLATION PROCEDURE	2-33
2.10	TRAY HEATER (OPTIONAL PAPER FEED UNIT)	2-35
2.10.1	COMPONENT CHECK	2-35
2.10.2	INSTALLATION PROCEDURE	2-36
	For installing the tray heater in the D580 (Two-tray paper feed unit)	2-36
	For installing the tray heater in the D581 (LCT)	2-38
2.11	EXTERNAL USB KEYBOARD INSTALLATION	2-42
2.11.1	INSTALLATION PROCEDURE	2-42
2.12	CONTROLLER OPTIONS	2-44
2.12.1	OVERVIEW	2-44
	Controller Options	2-44
	Board, SD Card Slots	2-45
2.12.2	APPLICATION MERGE	2-47
	Overview	2-47
	Important Notes about SD Card Appli Move	2-47
	Move Exec	2-48
	Undo Exec	2-49
<b>3.</b>	<b>PREVENTIVE MAINTENANCE</b>	<b>3-1</b>
3.1	PM TABLES	3-1
<b>4.</b>	<b>REPLACEMENT AND ADJUSTMENT</b>	<b>4-1</b>
4.1	GENERAL CAUTIONS	4-1
4.1.1	LASER UNIT	4-1
4.1.2	USED TONER	4-1
4.2	SPECIAL TOOLS AND LUBRICANTS	4-2
4.2.1	SPECIAL TOOLS	4-2
4.2.2	LUBRICANTS	4-2

4.3 EXTERIOR COVERS .....	4-3
4.3.1 FRONT DOOR, UPPER AND LOWER INNER COVER .....	4-3
Upper Inner Cover .....	4-3
Lower Inner Cover .....	4-3
4.3.2 LEFT COVER .....	4-4
4.3.3 REAR COVER .....	4-4
4.3.4 RIGHT REAR COVER .....	4-5
4.3.5 TOP RIGHT AND TOP REAR COVER .....	4-6
4.3.6 OPERATION PANEL .....	4-6
When Installing the New Operation Panel .....	4-8
4.3.7 PAPER EXIT COVER .....	4-8
4.3.8 OUTPUT TRAY .....	4-8
4.4 LASER UNIT .....	4-10
4.4.1 CAUTION DECAL LOCATIONS .....	4-10
4.4.2 LASER UNIT .....	4-11
4.4.3 POLYGON MIRROR MOTOR .....	4-12
4.4.4 LASER SYNCHRONIZATION DETECTOR .....	4-12
4.4.5 LD UNIT .....	4-13
Laser Beam Pitch Adjustment .....	4-14
4.5 PCDU .....	4-16
4.5.1 PCDU (PHOTOCONDUCTOR AND DEVELOPMENT UNIT) .....	4-16
Reinstallation .....	4-17
4.5.2 DRUM .....	4-17
Re-installation .....	4-18
4.5.3 PICK-OFF PAWLS .....	4-19
Pick-off Pawl Position Adjustment .....	4-19
4.5.4 CHARGE ROLLER AND CLEANING ROLLER .....	4-20
4.5.5 DRUM CLEANING BLADE .....	4-21
Re-installation .....	4-21
4.5.6 ID SENSOR .....	4-21
4.6 DEVELOPMENT .....	4-22
4.6.1 DEVELOPMENT FILTER .....	4-22
4.6.2 DEVELOPMENT ROLLER .....	4-22
Cleaning Procedure .....	4-23
4.6.3 DEVELOPER .....	4-24
4.6.4 TD SENSOR .....	4-27
4.7 TRANSFER .....	4-28
4.7.1 TRANSFER BELT UNIT .....	4-28

4.7.2	TRANSFER BELT.....	4-29
4.7.3	TONER OVERFLOW SENSOR.....	4-31
4.7.4	TRANSFER BELT CLEANING BLADE.....	4-31
4.8	PAPER FEED .....	4-32
4.8.1	PAPER FEED UNIT.....	4-32
Tray 1 and Tray 2.....		4-32
4.8.2	PICK-UP, FEED AND SEPARATION ROLLERS.....	4-33
Tray 1 and Tray 2.....		4-33
4.8.3	TRAY LIFT MOTOR.....	4-34
4.8.4	RELAY, TRAY LIFT, PAPER END AND PAPER FEED SENSORS.....	4-35
Tray 1 and Tray 2.....		4-35
4.8.5	REGISTRATION SENSOR.....	4-36
Reinstall the registration sensor .....		4-37
4.9	FUSING .....	4-38
4.9.1	FUSING UNIT.....	4-38
4.9.2	WEB ROLLER UNIT .....	4-39
4.9.3	BRAKE PAD .....	4-40
4.9.4	WEB HOLDER ROLLER AND WEB ROLLERS .....	4-41
Installing a new web holder roller .....		4-42
Installing new web rollers .....		4-43
4.9.5	PRESSURE ROLLER CLEANING ROLLER .....	4-44
4.9.6	THERMOSTATS.....	4-45
4.9.7	THERMISTOR .....	4-46
4.9.8	HOT ROLLER STRIPPERS.....	4-47
4.9.9	FUSING LAMPS .....	4-48
4.9.10	HOT ROLLER AND PRESSURE ROLLER .....	4-50
4.10	PAPER EXIT .....	4-51
4.10.1	PAPER EXIT UNIT .....	4-51
4.10.2	FUSING EXIT, PAPER OVERFLOW, AND PAPER EXIT SENSORS	4-52
4.10.3	JUNCTION JAM SENSOR .....	4-53
4.10.4	PAPER EXIT MOTOR .....	4-53
4.11	DUPLEX.....	4-54
4.11.1	DUPLEX UNIT .....	4-54
4.11.2	RIGHT DOOR COVER .....	4-56
4.11.3	DUPLEX DOOR SENSOR.....	4-57
4.11.4	DUPLEX ENTRANCE SENSOR.....	4-57
4.11.5	DUPLEX EXIT SENSOR .....	4-58

4.11.6	DUPLEX/BY-PASS MOTOR.....	4-60
4.11.7	DUPLEX INVERTER MOTOR.....	4-61
4.12	BY-PASS.....	4-63
4.12.1	BY-PASS PAPER SIZE SENSOR/BY-PASS PAPER LENGTH SENSOR.....	4-63
	When reinstalling the by-pass paper size sensor .....	4-65
4.12.2	BY-PASS PAPER END SENSOR .....	4-66
4.12.3	BY-PASS PICK-UP, FEED AND SEPARATION ROLLER, TORQUE LIMITER.....	4-66
4.12.4	BY-PASS FEED CLUTCH.....	4-67
4.13	DRIVE AREA .....	4-68
4.13.1	PAPER FEED CLUTCH.....	4-68
	Tray 1 and Tray 2.....	4-68
4.13.2	DEVELOPMENT PADDLE MOTOR .....	4-68
4.13.3	TRANSFER/DEVELOPMENT MOTOR .....	4-69
4.13.4	DRUM MOTOR.....	4-69
4.13.5	FUSING MOTOR.....	4-70
4.13.6	WEB MOTOR .....	4-71
4.13.7	PAPER FEED MOTOR.....	4-72
4.13.8	TRANSFER BELT CONTACT MOTOR.....	4-72
4.13.9	REGISTRATION MOTOR.....	4-73
4.13.10	TONER SUPPLY MOTOR.....	4-74
4.14	ELECTRICAL COMPONENTS .....	4-75
4.14.1	CONTROLLER UNIT.....	4-75
4.14.2	CONTROLLER BOARD.....	4-75
	Before Replacing the Controller Board in the Model without HDD .....	4-75
	Replacement Procedure.....	4-75
	When Installing the New Controller Board.....	4-77
4.14.3	AFTER INSTALLING THE CONTROLLER BOARD.....	4-77
4.14.4	MOTHER BOARD .....	4-78
4.14.5	BCU .....	4-81
	When installing the new BCU.....	4-81
4.14.6	BRIDGE BOARD .....	4-82
4.14.7	IOB .....	4-82
4.14.8	PSU .....	4-83
4.14.9	HIGH VOLTAGE POWER SUPPLY .....	4-83
4.14.10	FUSING EXHAUST FAN.....	4-84
	When installing the fusing exhaust fan.....	4-84

4.14.11	CONTROLLER FAN .....	4-84
	When installing the controller fan .....	4-84
4.14.12	SD USB BOARD.....	4-85
4.14.13	LCDC BOARD .....	4-86
	When Installing the New LCDC Board .....	4-87
4.15	PRINT ADJUSTMENTS .....	4-88
4.15.1	OVERVIEW .....	4-88
4.15.2	PRINTING.....	4-88
	Registration - Leading Edge/Side-to-Side .....	4-88
	Blank Margin .....	4-89
	Main Scan Magnification .....	4-91
	Parallelogram Image Adjustment .....	4-91
4.15.3	TOUCH SCREEN CALIBRATION .....	4-92

## **5. SERVICE TABLES..... 5-1**

5.1	SERVICE PROGRAM MODE .....	5-1
5.1.1	SERVICE PROGRAM MODE OPERATION.....	5-1
	Service Mode Lock/Unlock.....	5-1
5.1.1	ENTERING SP MODE.....	5-1
	If The Power is Already On: .....	5-1
	If The Power is Already Off: .....	5-1
5.1.2	SERVICE PROGRAM MODE TABLES .....	5-2
	Service Table Key .....	5-2
5.2	SERVICE PROGRAM MODE TABLES .....	5-3
5.2.1	SP TABLES .....	5-3
5.3	SERVICE MAIN SP TABLES.....	5-4
5.3.1	SP1-XXX.....	5-4
5.4	ENGINE MAIN SP TABLES-1.....	5-14
5.4.1	SP1-XXX: FEED .....	5-14
5.5	ENGINE MAIN SP TABLES-2.....	5-23
5.5.1	SP2-XXX: DRUM.....	5-23
5.6	ENGINE MAIN SP TABLES-3.....	5-28
5.6.1	SP3-XXX: PROCESS .....	5-28
5.7	ENGINE MAIN SP TABLES-4.....	5-29
5.8	ENGINE MAIN SP TABLES-5.....	5-30
5.8.1	SP5-XXX: MODE .....	5-30
5.9	ENGINE MAIN SP TABLES-6.....	5-80
5.9.1	SP6-XXX: PERIPHERALS.....	5-80
5.10	ENGINE MAIN SP TABLES-7.....	5-86

5.10.1	SP7-XXX: DATA LOG .....	5-86
5.11	ENGINE MAIN SP TABLES-8.....	5-100
5.11.1	SP8-XXX: DATA LOG2 .....	5-100
5.12	ENGINE MAIN SP TABLES-9.....	5-127
5.12.1	INPUT CHECK TABLE .....	5-127
Copier.....		5-127
Table 1: Paper Height Sensor.....		5-130
Table 2: Paper Size Switch .....		5-130
Table 3: Paper Size (By-pass Table) .....		5-131
APS Original Size Detection.....		5-132
3000-Sheet Finisher (D636).....		5-133
1000-Sheet Finisher (D588).....		5-136
5.12.2	OUTPUT CHECK TABLE .....	5-137
Copier.....		5-137
1000-Sheet Finisher (D588).....		5-142
5.12.3	3000-SHEET FINISHER (D636).....	5-143
5.13	UPDATING THE FIRMWARE.....	5-145
5.13.1	BEFORE YOU BEGIN .....	5-145
5.13.2	UPDATING FIRMWARE.....	5-146
Preparation.....		5-146
Updating Procedure .....		5-146
Error Messages.....		5-147
Firmware Update Error.....		5-148
Recovery after Power Loss .....		5-148
5.13.3	HANDLING FIRMWARE UPDATE ERRORS.....	5-149
Error Message Table.....		5-149
5.14	UPLOADING/DOWNLOADING NVRAM DATA .....	5-151
5.14.1	UPLOADING NVRAM DATA (SP5-824).....	5-151
5.14.2	DOWNLOADING NVRAM DATA (SP5-825).....	5-152
5.15	SELF-DIAGNOSTIC MODE .....	5-153
5.15.1	SELF-DIAGNOSTIC MODE AT POWER ON .....	5-153
5.15.2	SELF-DIAGNOSTIC TEST FLOW.....	5-154
5.15.3	DETAILED SELF-DIAGNOSTIC MODE .....	5-154
5.16	USING THE DEBUG LOG .....	5-155
5.16.1	OVERVIEW .....	5-155
5.16.2	SWITCHING ON AND SETTING UP SAVE DEBUG LOG .....	5-155
4-Digit Entries for Keys 1 to 10.....		5-158
Key to Acronyms .....		5-159

Retrieving the Debug Log from the HDD.....	5-160
5.17 SMC LIST CARD SAVE FUNCTION.....	5-161
5.17.1 OVERVIEW .....	5-161
SMC List Card Save.....	5-161
5.17.2 PROCEDURE.....	5-161
5.17.3 FILE NAMES OF THE SAVED SMC LISTS .....	5-163
5.17.4 ERROR MESSAGES.....	5-163
<b>6. TROUBLESHOOTING .....</b>	<b>6-1</b>
6.1 SERVICE CALL CONDITIONS.....	6-1
6.1.1 SUMMARY .....	6-1
6.1.2 SC CODE DESCRIPTIONS.....	6-2
SC Tables: SC1xx.....	6-2
SC Tables: SC2xx.....	6-3
SC Tables: SC3xx.....	6-6
SC Tables: SC4xx.....	6-9
SC Tables: SC5xx.....	6-11
SC Tables: SC6xx.....	6-20
SC Tables: SC7xx.....	6-27
SC Tables: SC8xx.....	6-41
SC Tables: SC9xx.....	6-63
6.2 ELECTRICAL COMPONENT DEFECTS.....	6-68
6.2.1 SENSORS .....	6-68
6.2.2 SWITCHES.....	6-72
6.3 BLOWN FUSE CONDITIONS.....	6-73
6.4 FUSES.....	6-74
<b>7. ENERGY SAVING.....</b>	<b>7-1</b>
7.1 ENERGY SAVE .....	7-1
7.1.1 ENERGY SAVER MODES .....	7-1
Timer Settings .....	7-1
Return to Stand-by Mode .....	7-2
Recommendation .....	7-2
7.1.2 ENERGY SAVE EFFECTIVENESS.....	7-2
7.2 PAPER SAVE .....	7-3
7.2.1 EFFECTIVENESS OF DUPLEX/COMBINE FUNCTION.....	7-3
1. Duplex: .....	7-3
2. Combine mode:.....	7-3
3. Duplex + Combine:.....	7-4



How to calculate the paper reduction ratio ..... 7-5

# READ THIS FIRST

## Safety Notices

### Important Safety Notices

#### Prevention of Physical Injury

1. Before disassembling or assembling parts of the main machine and peripherals, make sure that the power cord of the main machine is unplugged.
2. The wall outlet should be near the machine and easily accessible.
3. Note that some components of the machine and the paper tray unit are supplied with electrical voltage even if the main power switch is turned off.
4. If any adjustment or operation check has to be made with exterior covers off or open while the main switch is turned on, keep hands away from electrified or mechanically driven components.
5. If the Start key is pressed before the machine completes the warm-up period (the Start key starts blinking red and green alternatively), keep hands away from the mechanical and the electrical components as the machine starts making prints as soon as the warm-up period is completed.
6. The inside and the metal parts of the fusing unit become extremely hot while the machine is operating. Be careful to avoid touching those components with your bare hands.

#### **WARNING**

- To prevent a fire or explosion, keep the machine away from flammable liquids, gases, and aerosols.

#### Health Safety Conditions

1. Toner and developer are non-toxic, but if you get either of them in your eyes by accident, it may cause temporary eye discomfort. Immediately wash eyes with plenty of water. If unsuccessful, get medical attention.
2. This machine, which uses a high voltage power source, can generate ozone gas. High ozone density is harmful to human health. Therefore, the machine must be installed in a well-ventilated room.

## Observance of Electrical Safety Standards

1. This machine and its peripherals must be serviced by a customer service representative who has completed the training course on those models.
2. The NVRAM on the system control board has a lithium battery which can explode if replaced incorrectly. Replace the NVRAM only with an identical one. The manufacturer recommends replacing the entire NVRAM. Do not recharge or burn this battery. Used NVRAM must be handled in accordance with local regulations.

## Handling Toner

- Work carefully when removing paper jams or replacing toner bottles or cartridges to avoid spilling toner on clothing or the hands.
- If toner is inhaled, immediately gargle with large amounts of cold water and move to a well ventilated location. If there are signs of irritation or other problems, seek medical attention.
- If toner gets on the skin, wash immediately with soap and cold running water.
- If toner gets into the eyes, flush the eyes with cold running water or eye wash. If there are signs of irritation or other problems, seek medical attention.
- If toner is swallowed, drink a large amount of cold water to dilute the ingested toner. If there are signs of any problem, seek medical attention.
- If toner spills on clothing, wash the affected area immediately with soap and cold water. Never use hot water! Hot water can cause toner to set and permanently stain fabric.
- Always store toner and developer supplies such as toner and developer packages, cartridges, and bottles (including used toner and empty bottles and cartridges) out of the reach of children.
- Always store fresh toner supplies or empty bottles or cartridges in a cool, dry location that is not exposed to direct sunlight.

### **WARNING**

- Do not use a vacuum cleaner to remove spilled toner (including used toner). Vacuumed toner may cause a fire or explosion due to sparks or electrical contact inside the cleaner. However, it is possible to use a cleaner designed to be dust explosion-proof. If toner is spilled over the floor, sweep up spilled toner slowly and clean up any remaining toner with a wet cloth.

## Safety and Ecological Notes for Disposal

1. Do not incinerate toner bottles or used toner. Toner dust may ignite suddenly when exposed to an open flame.
2. Dispose of used toner, the maintenance unit which includes developer or the organic photoconductor in accordance with local regulations. (These are non-toxic supplies.)
3. Dispose of replaced parts in accordance with local regulations.
4. When keeping used lithium batteries in order to dispose of them later, do not put more than 100 batteries per sealed box. Storing larger numbers or not sealing them apart may lead to chemical reactions and heat build-up.

## Laser Safety

The Center for Devices and Radiological Health (CDRH) prohibits the repair of laser-based optical units in the field. The optical housing unit can only be repaired in a factory or at a location with the requisite equipment. The laser subsystem is replaceable in the field by a qualified Customer Engineer. The laser chassis is not repairable in the field. Customer engineers are therefore directed to return all chassis and laser subsystems to the factory or service depot when replacement of the optical subsystem is required.

### **WARNING**

- Use of controls, or adjustment, or performance of procedures other than those specified in this manual may result in hazardous radiation exposure.

### **WARNING**

- Turn off the main switch before attempting any of the procedures in the Laser Optics Housing Unit section. Laser beams can seriously damage your eyes.

### CAUTION MARKING:









3d-laser\_decal

# Conventions in this Manual

## Symbols and Abbreviations

This manual uses several symbols and abbreviations. The meaning of those symbols and abbreviations are as follows:

	See or Refer to
	Clip ring
	Screw
	Connector
	Clamp
	E-ring
SEF	Short Edge Feed
LEF	Long Edge Feed

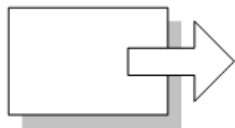

**Short Edge Feed (SEF)**

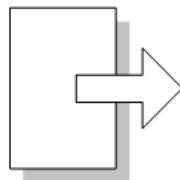

**Long Edge Feed (LEF)**

## Cautions, Notes, etc.

The following headings provide special information:

### **WARNING**

- FAILURE TO OBEY WARNING INFORMATION COULD RESULT IN SERIOUS INJURY OR DEATH.

### **CAUTION**

- Obey these guidelines to ensure safe operation and prevent minor injuries.

### **Note**

- This information provides tips and advice about how to best service the machine.

# **PRODUCT INFORMATION**



---

# 1. PRODUCT INFORMATION

## 1.1 SPECIFICATIONS

See "Appendices" for the following information:

- General Specifications
- Optional Equipment



## 1.2 MACHINE CONFIGURATION

### 1.2.1 PRINTER

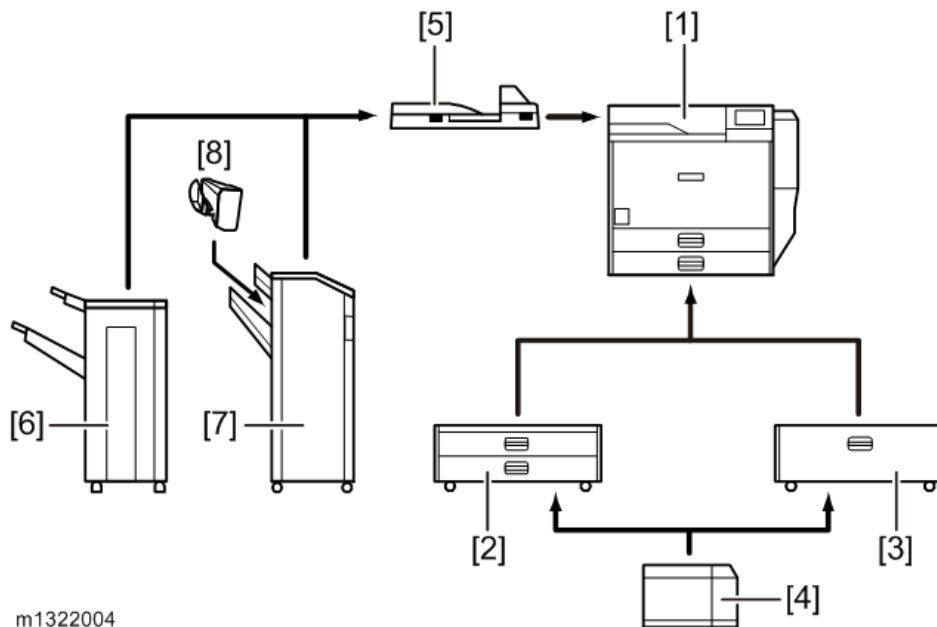

**Key:** Symbol: **U:** Unique option, **C:** Option also used with other products

Item		Callout	Key	Machine Code
Main Frame	M132	[1]	-	M132
External Options	Two-Tray Paper Feed Unit	[2]	C	D580
	2000-sheet LCT	[3]	C	D581
	1200-sheet LCT	[4]	C	D631
	Bridge Unit	[5]	C	D634
	1000-sheet Finisher (See Note 1)	[6]	C	D588
	3000-Sheet Finisher (See Note 1)	[7]	C	D636
	-Punch Unit (See Note 2)	-	C	D570-00 (2/3-hole) (NA)

Item		Callout	Key	Machine Code
	-Punch Unit (See Note 2)	-	C	D570-01 (2/4-hole) (EU)
	-Punch Unit (See Note 2)	-	C	D570-02 (4-hole) (Scandinavia)
	-Output Jogger Unit (See Note 2)	[8]	C	B703
Internal Options	HDD	-	U	M416
	Memory Unit 512 MB	-	C	D594
	IPDS Unit	-	C	M416
	Netware	-	C	M416
	VM Card	-	C	D640
	Font SD Card	-	C	D641 (EU)
	Gigabit Ethernet	-	C	G874 (EU) M394 (NA)
	IEEE 802.11a/g, g	-	C	M344
	IEEE 1284	-	C	B679

**NOTE:**

1. The finisher requires the bridge unit and two-tray paper feed unit or 2000-sheet LCT. The 1000-sheet finisher and 3000-sheet finisher cannot be installed together.
2. The punch unit and output jogger unit requires the 3000-sheet finisher.

## 1.3 GUIDANCE FOR THOSE WHO ARE FAMILIAR WITH PREDECESSOR PRODUCTS

The M132 series are successor models to the G179 series. If you have experience with the predecessor products, the following information will be of help when you read this manual.

### Different Points from Predecessor Products

	M132	G179
Controller Type	GW+ Controller	GW Controller
Operation Panel	4.3" touch panel includes USB/SD slot	4-line LCD
USB2.0/SD Slot	Standard	Not supported
Light Detect Function	Available	Not supported
SMC data	SD card down load or printing	Printing only
Safety Shut Down Function	Available	Not Available
PDF Direct	Standard	Not supported
Data Overwrite Security	Standard	Option
HDD Encryption	Standard	Option

## 1.4 OVERVIEW

### 1.4.1 COMPONENT LAYOUT

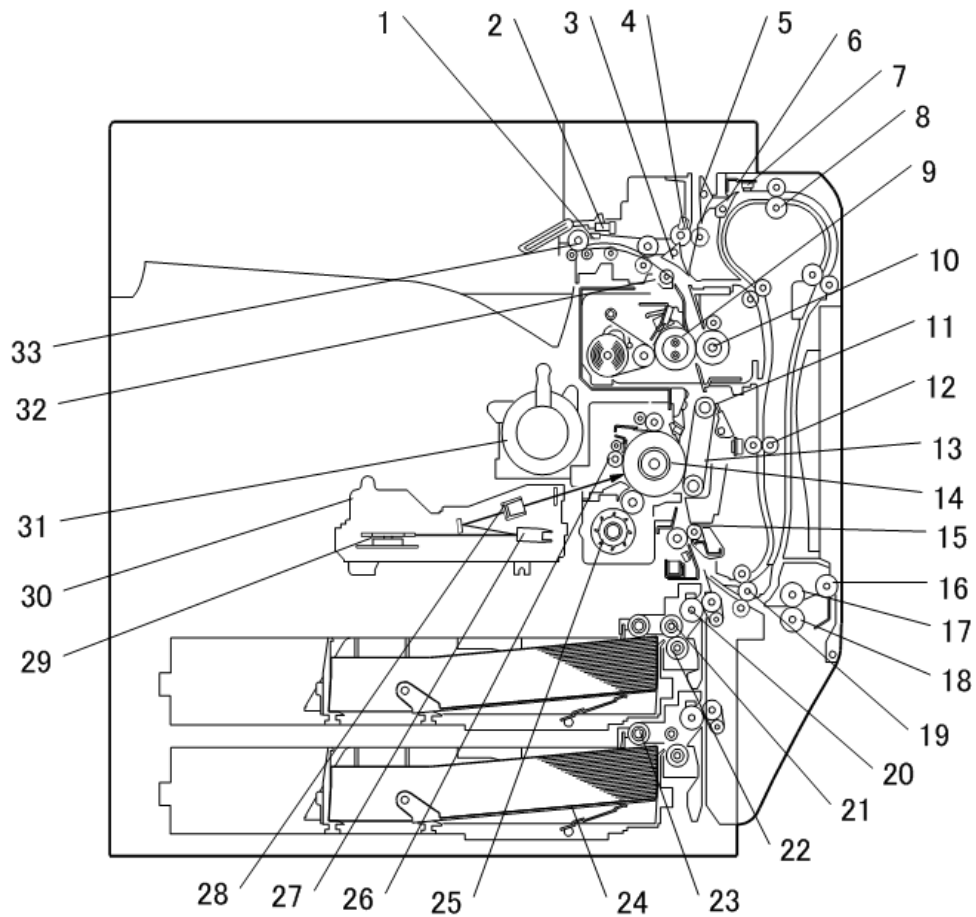

g179D002

1	Paper Exit Sensor	17	By-pass Feed Roller
2	Paper Overflow Sensor	18	By-pass Separation Roller
3	Junction Gate 1	19	Duplex/by-pass transport roller
4	Junction Jam Sensor	20	Upper Relay Belt
5	Duplex Inverter Gate	21	Feed Roller
6	Junction Gate 2	22	Separation Roller
7	Duplex Entrance Sensor	23	Pick-up Roller
8	Duplex Inverter Roller	24	Bottom Plate

## Overview

9	Hot Roller	25	Development Unit
10	Pressure Roller	26	Charge Roller
11	Transfer Belt Cleaning Blade	27	F $\theta$ Mirror
12	Duplex Transport Roller	28	Barrel Toroidal Lens (BTL)
13	Transfer Belt	29	Polygonal Mirror Motor
14	OPC Drum	30	Laser Unit
15	Registration Roller	31	Toner Bottle Holder
16	By-pass Pick-up Roller	32	Fusing Exit Sensor
		33	Exit Roller

### 1.4.2 PAPER PATH

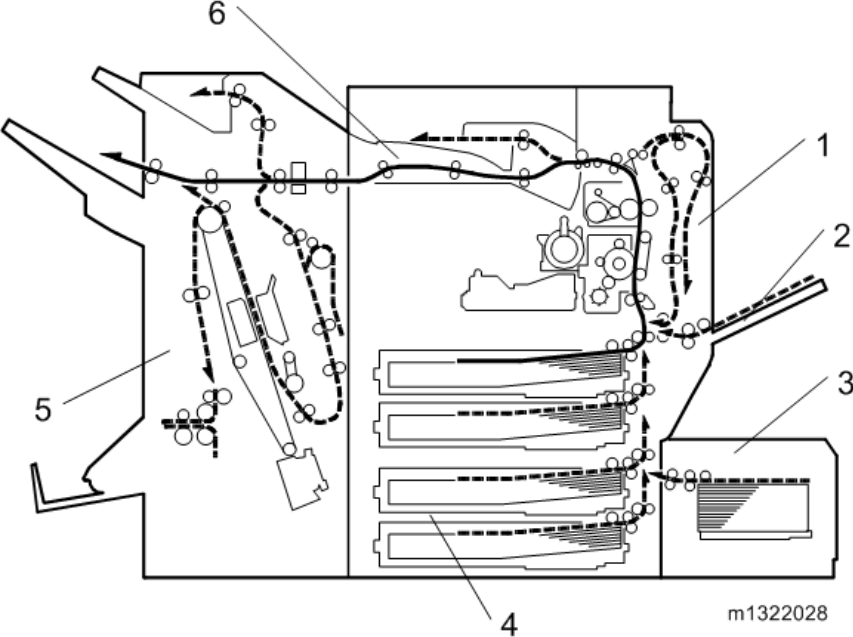

1	Duplex Unit
2	By-pass Tray
3	Large Capacity Tray (LCT: 1200-sheet)
4	Paper Tray Unit
5	Two-Tray Finisher
6	Bridge Unit

### 1.4.3 DRIVE LAYOUT

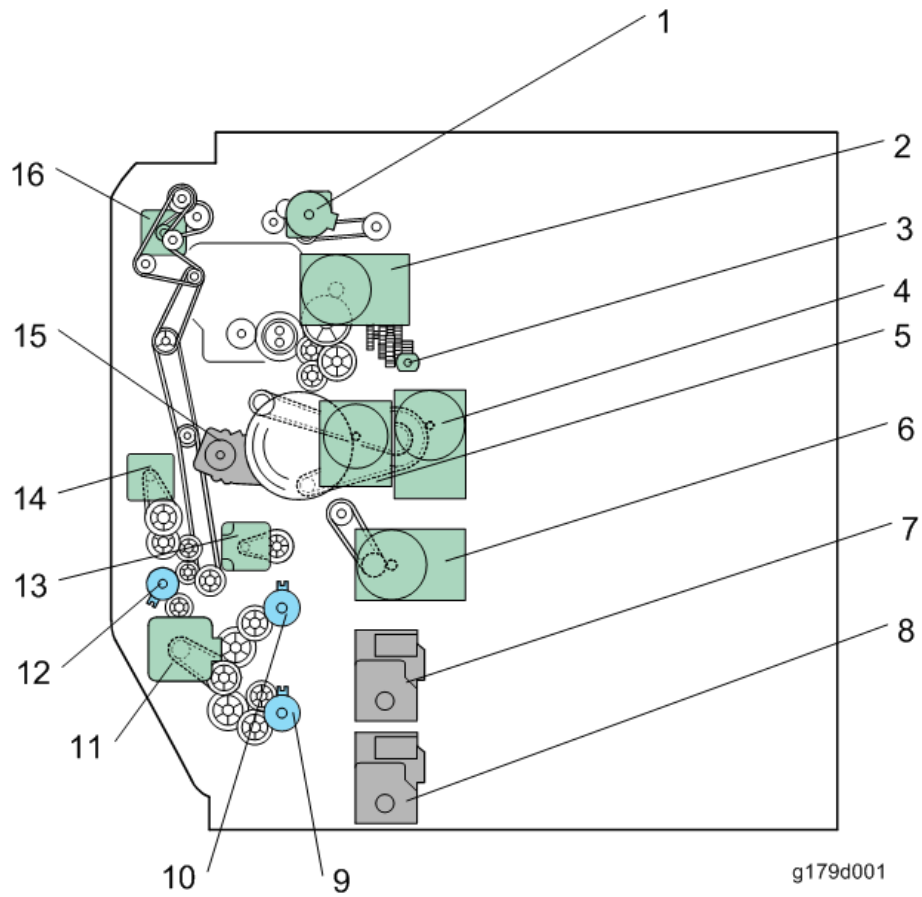

1	Paper Exit Motor	9	Paper Feed Clutch 2
2	Fusing Motor	10	Paper Feed Clutch 1
3	Web Motor	11	Feed Motor
4	Transfer/Development Motor	12	By-pass Paper Feed Clutch
5	Drum Motor	13	Registration Motor
6	Development Paddle Motor	14	Duplex/By-pass Motor
7	Tray Lift Motor 1	15	Transfer Belt Contact Motor
8	Tray Lift Motor 2	16	Duplex Inverter Motor

# **INSTALLATION**





## 2. INSTALLATION

### 2.1 INSTALLATION REQUIREMENTS

**★ Important**

- Install the machine in a safe place for keeping security.
- Make sure that the operation instructions are kept at a customer's hand.

#### 2.1.1 ENVIRONMENT

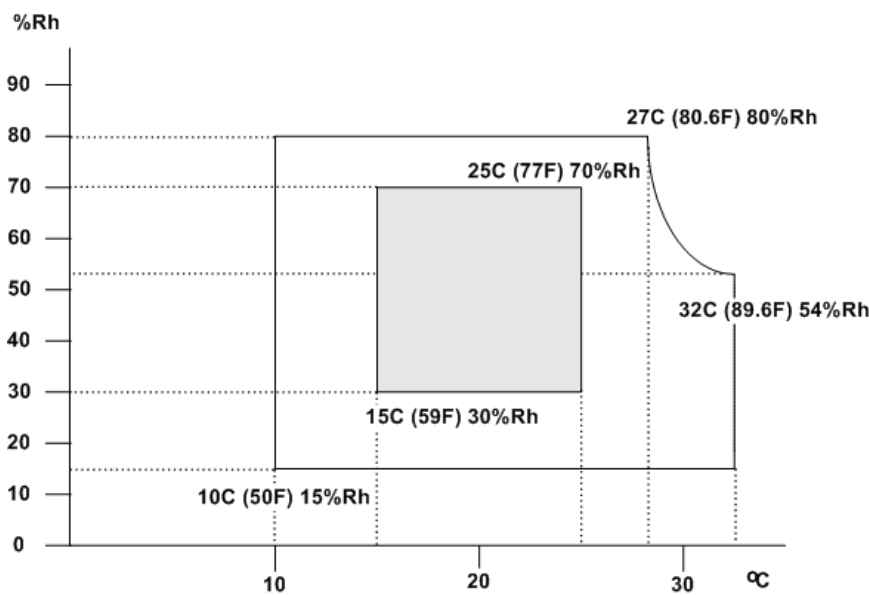

Temperature Range:	10°C to 32°C (50°F to 90°F)
Humidity Range:	15% to 80% RH
Ambient Illumination:	Less than 1,500 lux (do not expose to direct sunlight.)
Ventilation:	Room air should turn at least 30 m <sup>3</sup> /hr/person
Ambient Dust:	Less than 0.10 mg/m <sup>3</sup> (2.7 x 10 <sup>-6</sup> oz/yd <sup>3</sup> )

## Installation Requirements

1. Avoid areas exposed to sudden temperature changes:
  - 1) Areas directly exposed to cool air from an air conditioner.
  - 2) Areas directly exposed to heat from a heater.
2. Do not place the machine where it will be exposed to corrosive gases.
3. Do not install the machine at any location over 2,000 m (6,500 ft.) above sea level.
4. Place the main machine on a strong and level base. Inclination on any side should be no more than 5 mm (0.2").
5. Do not place the machine where it may be subjected to strong vibrations.

### 2.1.2 MACHINE LEVEL

Front to back:	Within 5 mm (0.2") of level
Right to left:	Within 5 mm (0.2") of level

### 2.1.3 MINIMUM SPACE REQUIREMENTS

Place the main machine near the power source, providing clearance as shown:

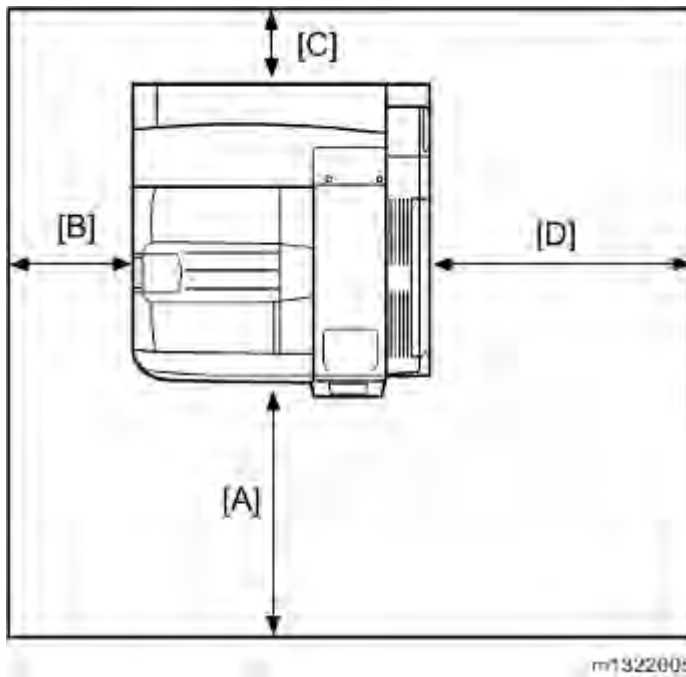

- Front [A]: Over 75 cm (29.6")
- Left [B]: 10 cm (4")
- Rear [C]: 10 cm (4")
- Right [D]: 55 cm (21.7")

#### ⓘ Note

- The 75 cm (29.6") recommended for the space at the front is for pulling out the paper tray only. If the operator stands at the front of the main machine, more space is required.

## 2.1.4 POWER REQUIREMENTS

### CAUTION

- Make sure that the wall outlet is near the main machine and easily accessible. Make sure the plug is firmly inserted in the outlet.
  - Avoid multi-wiring.
  - Be sure to ground the machine.
1. Input voltage level:  
North America 120 V to 127 V, 60 Hz: More than 12 A  
Europe/Asia 220 V to 240V, 50 Hz/60 Hz: More than 7 A
  2. Permissible voltage fluctuation:

	For printing images	For operating
North America	+8.66 / -10 %	+8.66 / -15 %
Others	+/-10 %	+/-15 %

3. Never set anything on the power cord.

## 2.2 MAIN MACHINE INSTALLATION

### 2.2.1 INSTALLATION OVERVIEW

The installation procedures of the following items are in the Operating Instructions:

#### Main Machine and Hardware Options

- Printer M132 (main machine) Installation
- Paper Feed Unit: D580
- LCIT PB3140: D581

#### Controller Options

- HDD: M416
- Data Storage Card: D594
- IEEE1284 Interface Board: B679
- IEEE802.11a/g Interface Unit: M344
- Gigabit Ethernet: G874 (EU only), M394 (NA only)
- VM Card: D640
- IPDS Unit: M416
- SD Card for Netware Printing: M416
- SD Card for fonts: D641 (EU only)

#### Note

- The bridge unit (D634) and either the 2,000-sheet LCT (D581) or the paper tray (D580) must be installed before the finisher SR3120 (D636) or SR3090 (D588) is installed.

The installation procedures of the following options are in this service manual:

#### Hardware Options

- LCIT RT3020: D631
- Bridge Unit: D634 (for Finisher SR3120 and SR3090)
- Finisher SR3120: D636
  - Punch Unit: D570 (for Finisher SR3120)
  - Jigger Unit: B703 (for Finisher SR3120)
- Finisher SR3090: D588

## 2.2.2 POWER SOCKET FOR PERIPHERAL

### **⚠ CAUTION**

- Rating voltage for peripheral: Make sure to plug the cable into the correct socket.



**Finisher**  
Rating voltage output  
connector for accessory  
Max. DC24V

w\_m1322002

## 2.2.3 INSTALLATION FLOW CHART

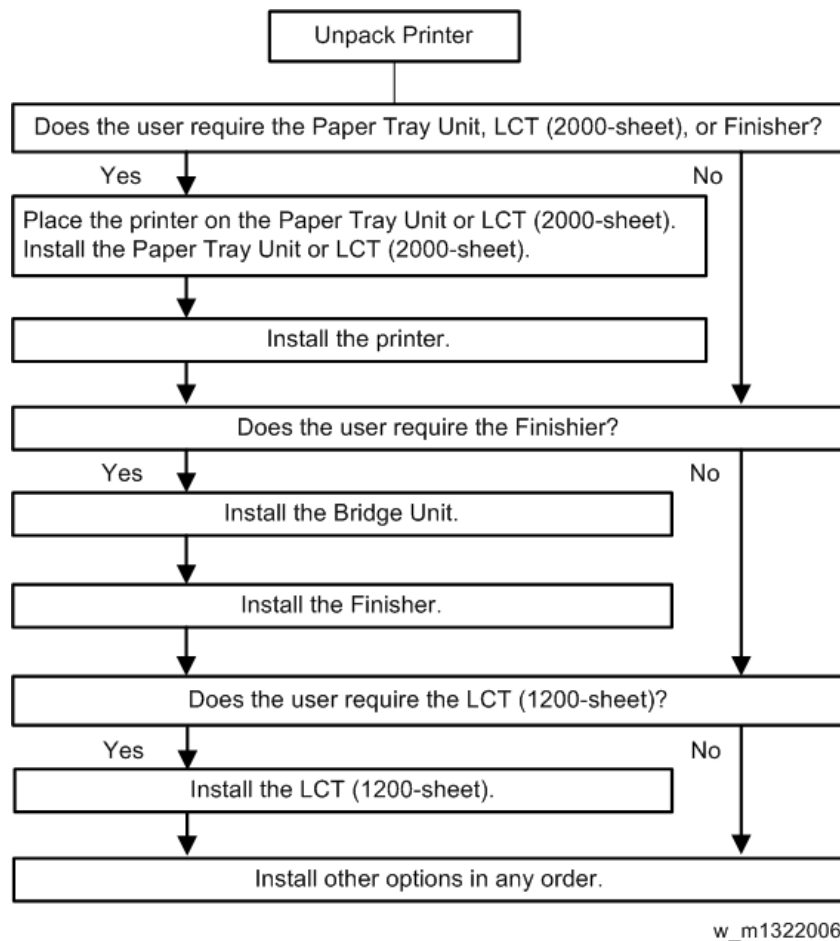

## 2.2.4 MOVING THE MACHINE

This section shows you how to manually move the machine from one floor to another floor. See the section "Transporting the Machine" if you have to pack the machine and move it a longer distance.

1. Remove all trays from the optional paper feed unit or LCT.

## 2.2.5 TRANSPORTING THE MACHINE

1. Make sure there is no paper left in the paper trays. Then fix down the bottom plates with a sheet of paper and tape.
2. Do one of the following:
  - Attach shipping tape to the covers and doors.
  - Shrink-wrap the machine tightly.



## 2.3 1200-SHEET LCT INSTALLATION (D631)

### 2.3.1 COMPONENT CHECK

Check the quantity and condition of the components against the following list.

No.	Description	Q'ty
1	Front Bracket	1
2	Rear Bracket	1
3	Stud Screw	4
4	Joint Pin	2
5	LCT	1

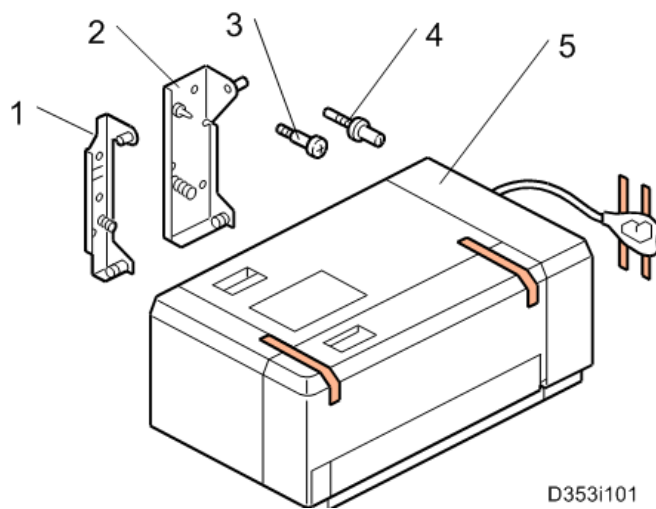

## 2.3.2 INSTALLATION PROCEDURE

### ⚠ CAUTION

- Unplug the main machine power cord before starting the following procedure.

### 📌 Note

- The Paper Tray Unit (D580) or LCT 2000-sheet (D581) must be installed before installing this 1200-sheet LCT.

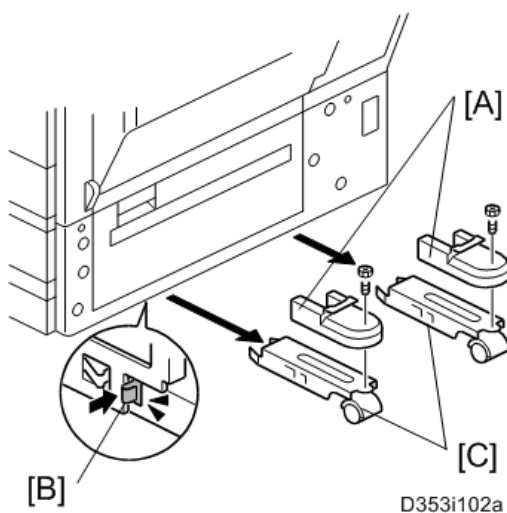

- Unpack the LCT and remove the tapes.
- Remove the stand covers [A].
- Release the locks [B] of the front and rear caster stands.
- Remove the caster stands [C].

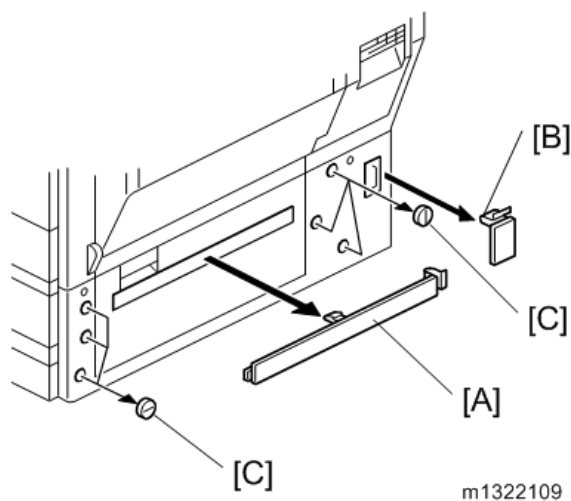

- Remove the paper path cover [A], connector cover [B] and six hole covers [C].

## 1200-sheet LCT Installation (D631)

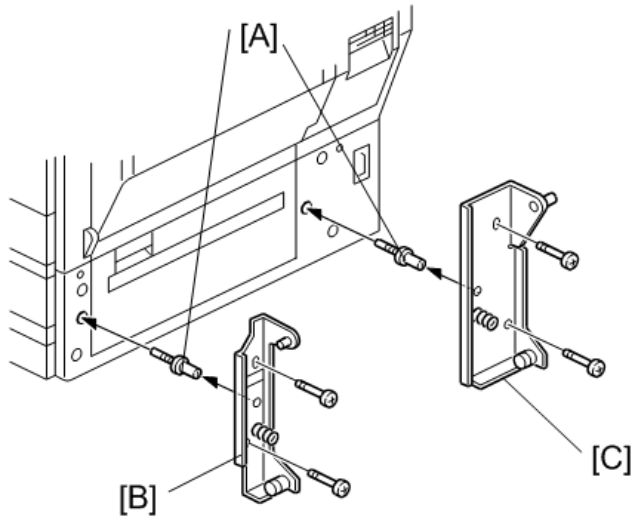

D353i104a

6. Insert the joint pins [A].
7. Attach the front [B] and rear brackets [C]. (⚙️ x2 each)

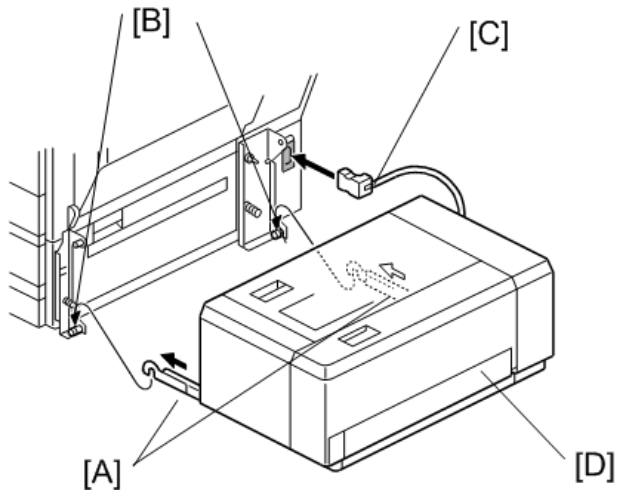

D353i105a

8. Pull out the front and rear rails [A], and then hang them on each bracket [B].
9. Connect the LCT cable [C] to the main machine.
10. Slide the LCT [D] into the main machine.
11. Make sure that the front and rear sides of the LCT are closely attached to the main machine.

### 2.3.3 SIDE FENCE POSITION CHANGE

1. Open the right door of the LCT.
2. Push the down switch to lower the tray bottom plate until it reaches its lowest position.

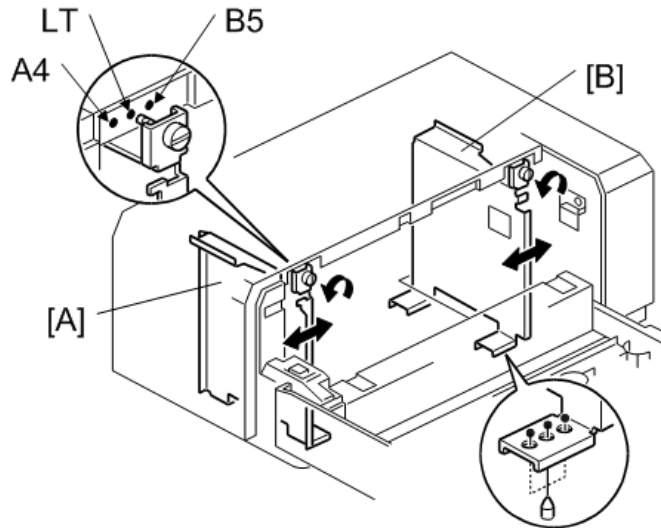

d353i106

3. Remove the front and rear side fences [A, B] (🔧 x 1 each).
4. Install the side fences in the correct position (A4 LEF/ LT LEF/ B5 LEF).

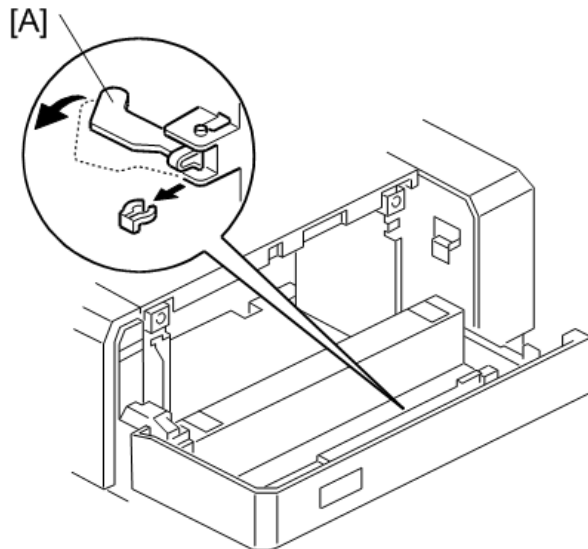

d353i107a

5. Pull the end fence [A] for B5 size paper as shown (🔧 x 1) if the side fences are adjusted for B5 size paper.
6. Close the right door.
7. Turn on the main power switch, and then go into the SP mode.
8. Input the correct paper size for the 1200-sheet LCT with SP5181-017.

## 2.4 BRIDGE UNIT INSTALLATION (D634)

### 2.4.1 COMPONENT CHECK

Check the quantity and condition of the components against the following list.

No.	Description	Q'ty
1	Bridge Unit	1
2	Frame Cover	1
3	Knob Screw	1
4	Long Knob Screw	1
5	Holder Bracket Cover	1
6	Guide	2

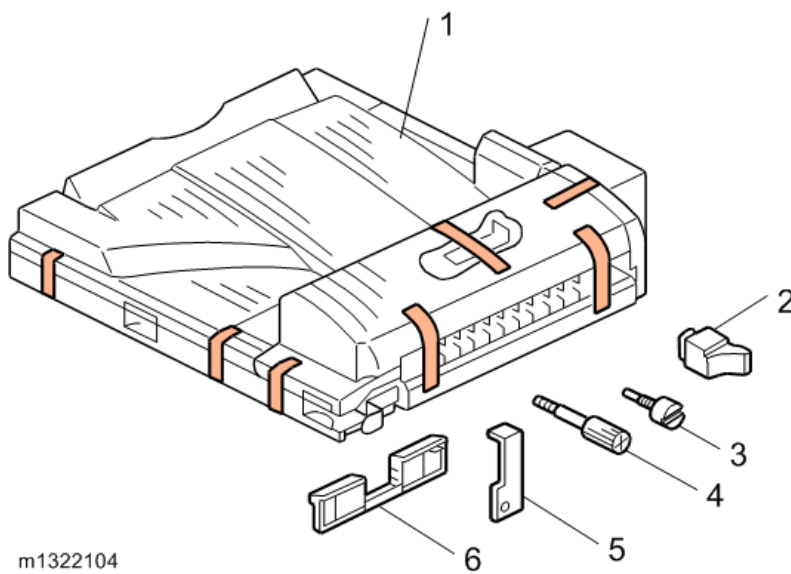

## 2.4.2 INSTALLATION PROCEDURE

### ⚠ CAUTION

- Unplug the power cord of the main machine before starting the following procedure.

### 📌 Note

- If you will install the finisher unit (D588, D636) on the machine, install it after installing the bridge unit (D634).

1. Remove all tapes.



2. If the sensor feeler [A] is out, fold it into the machine.



3. Remove the operation panel cover [A] (🔑 x 1).

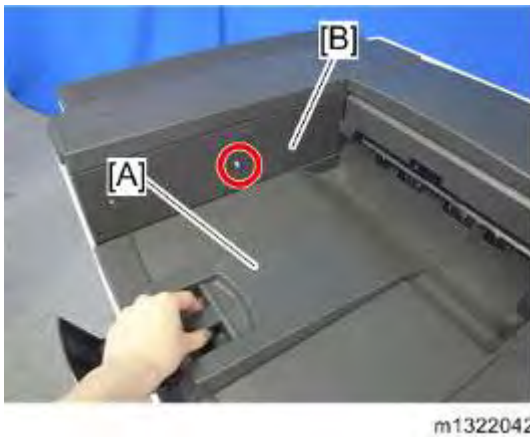

4. Remove the inner tray [A].

## Bridge Unit Installation (D634)

5. Remove the connector cover [B] (🔑 x 1).

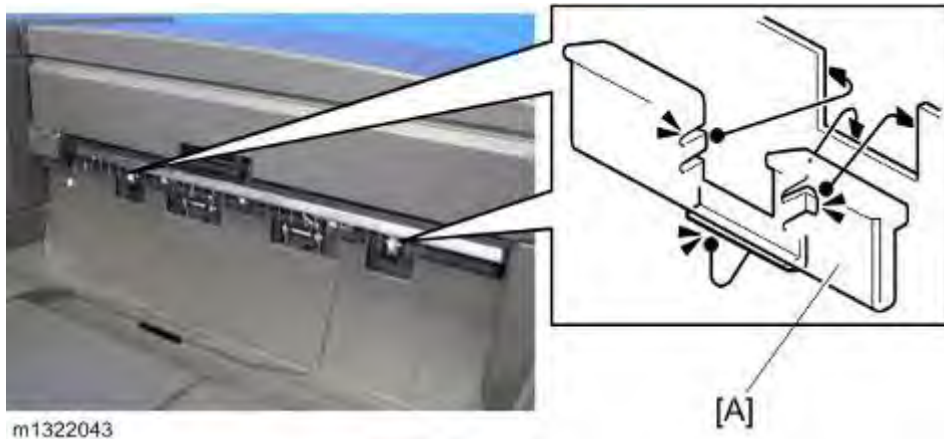

6. Attach the two guides [A] to the cutouts in the paper exit.

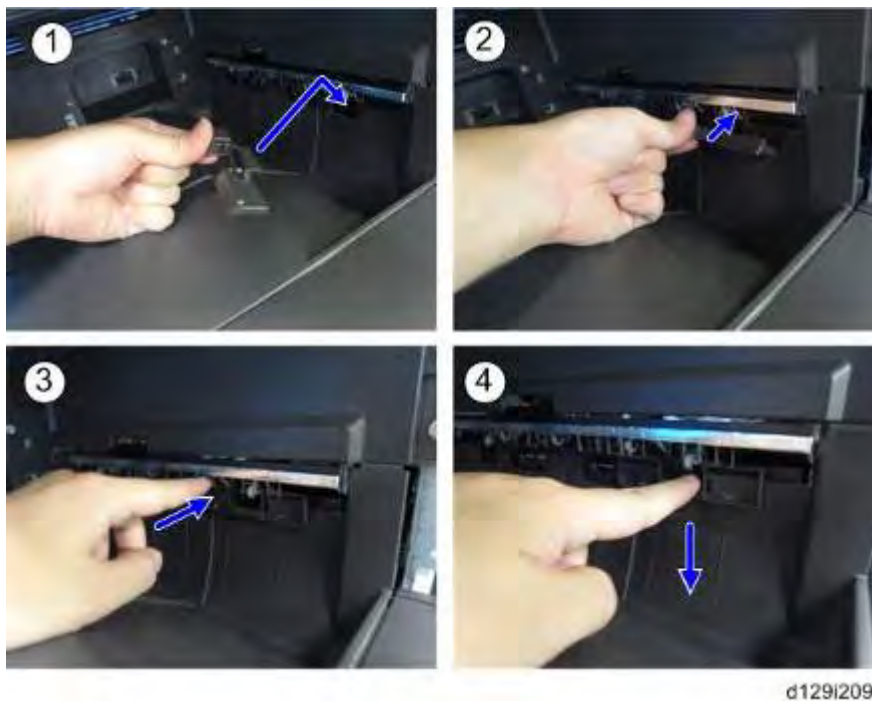

- 1) Place the lower hook of the guide in the cutout of the paper exit.
- 2) Attach the guide as shown until the two side hooks hold the paper exit.
- 3) Press the guide.
- 4) Press down the guide as shown.



7. Install the bridge unit [A] in the machine.



8. Secure the bridge unit with the long knob screw [A].



9. Open the bridge unit cover [A].

10. Secure the bridge unit with knob screw [B].



## Bridge Unit Installation (D634)

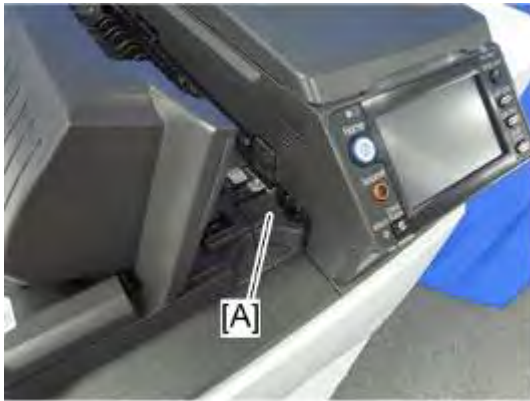

m1322047

11. Attach the frame cover [A].
12. Close the bridge unit cover.
13. Reinstall the machine.
14. Install the optional finisher (refer to the finisher installation procedure).

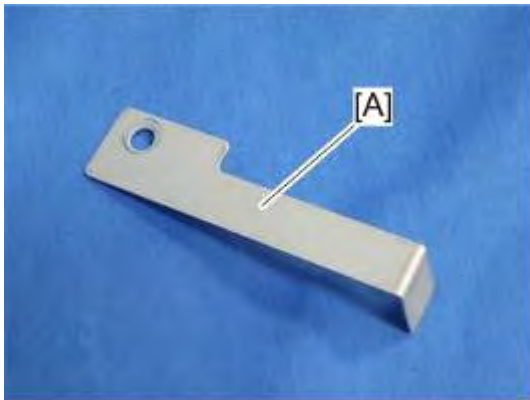

m1322048

### ↓ Note

- The holder bracket [A] is used in the installation procedure of the finisher (D588, D636). Do not install it at this time.



m1322049

15. Pull out the extension tray [A] only if the 1000-sheet finisher (D588) will be installed on the main machine.
16. Turn on the main power switch of the machine.
17. Check the bridge unit operation.

## 2.5 1000-SHEET FINISHER (D588)

### 2.5.1 ACCESSORY CHECK

Check the quantity and condition of the accessories against the following list.

No.	Description	Q'ty	For this model
1	Grounding Plate	1	Yes
2	Rear Joint Bracket	1	Not used
3	Front Joint Bracket	1	Yes
4	Rear Joint Bracket	1	Yes
5	Copy Tray	1	Yes
6	Screw - M3 x 8	1	Yes
7	Screw - M4 x 13	4	Yes
8	Knob Screw - M3 x 8	1	Yes
9	Knob Screw - M4 x 10	1	Yes
10	Screw - M4 x 25	3	Not used
11	Staple Position Decal	1	Not used

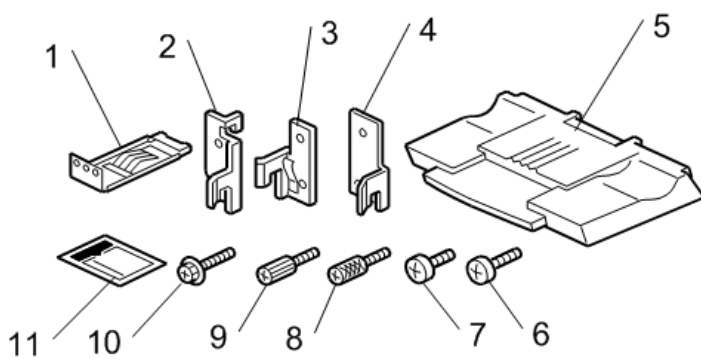

d588i100

## 2.5.2 INSTALLATION PROCEDURE

### ⚠ CAUTION

- Unplug the main machine power cord before starting the following procedure.

If this finisher is installed, the Bridge Unit (D634) and Paper Feed Unit (D580) or LCT (D581) must be installed before installing this finisher.

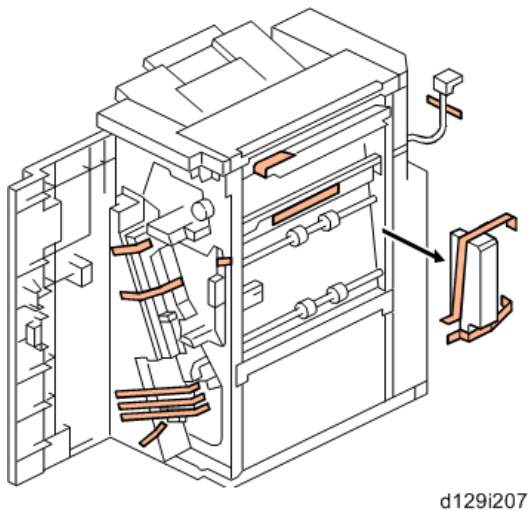
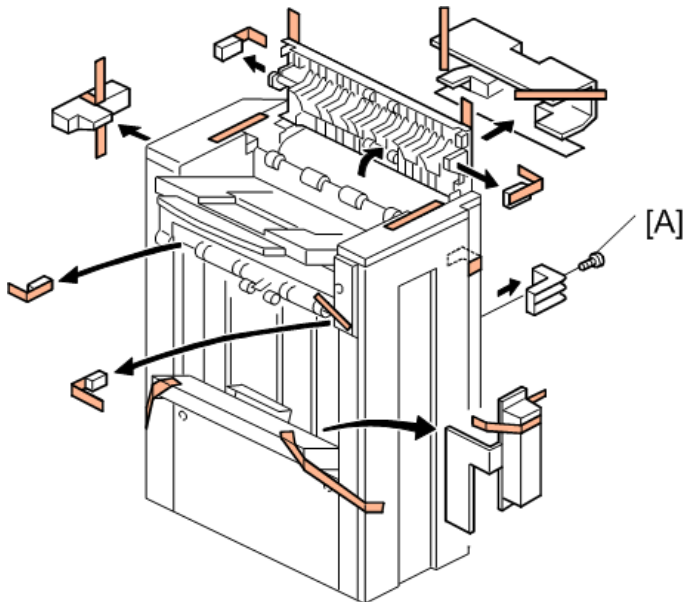

1. Unpack the finisher and remove the tapes.

#### ↓ Note

- Be sure to keep screw [A]. It will be needed to secure the grounding plate in step 3.

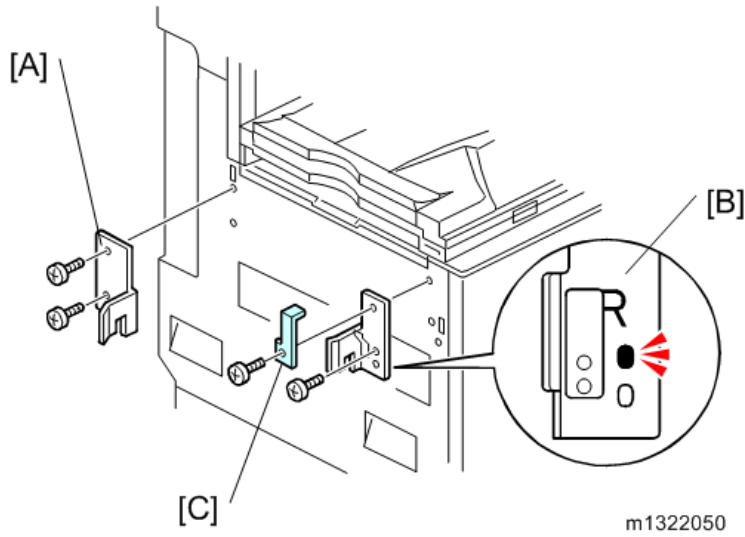

2. Install the rear joint bracket [A] (🔩 x 2; M4 x 13) and front joint bracket [B] (🔩 x 2; M4 x 13).

**Note**

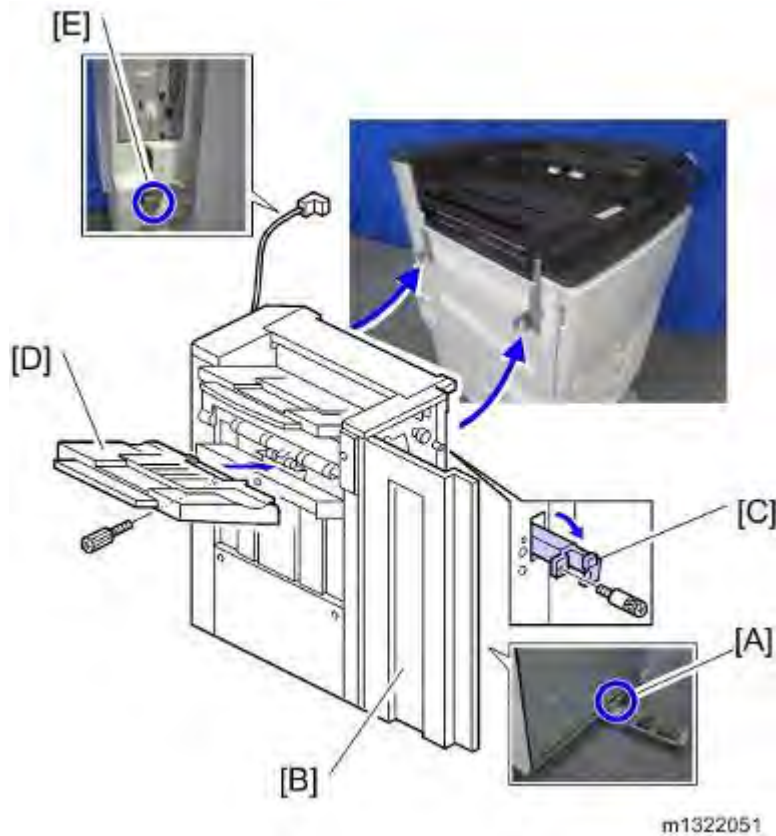

- Holder bracket [C] must be placed outside the front joint bracket [B]. This bracket is provided with the Bridge Unit (D634).



3. Install the grounding plate [A] on the finisher (🔩 x 2; M3 x 8)

## 1000-sheet Finisher (D588)

### Note

- Use the screw removed in step 1 and the screw from the accessory box.
4. Open the front door [B]. Then pull the locking lever [C].
  5. Align the finisher on the joint brackets, and lock it in place by pushing the locking lever.
  6. Secure the locking lever ( x 1; knob M3 x 8) and close the front door.
  7. Install the copy tray [D] ( x 1; knob M4 x 10).
  8. Connect the finisher cable [E] to the main machine as shown above.
  9. Turn on the main power switch and check the finisher operation.

## 2.6 3000-SHEET FINISHER (D636)

### 2.6.1 ACCESSORY CHECK

Check the quantity and condition of the accessories against the following list.

No.	Description	Q'ty
1	Rear joint bracket	1
2	Front joint bracket	1
3	Ground (earth) plate	1
4	Tapping screws - M4 x14	4
5	Tapping screws - M3 x 8	1
6	Tapping screws - M3 x 6	6
7	Upper output tray	1
8	Support Tray	1
9	Cushion (with double-sided tape)	1
10	Small Ground (earth) plate	2

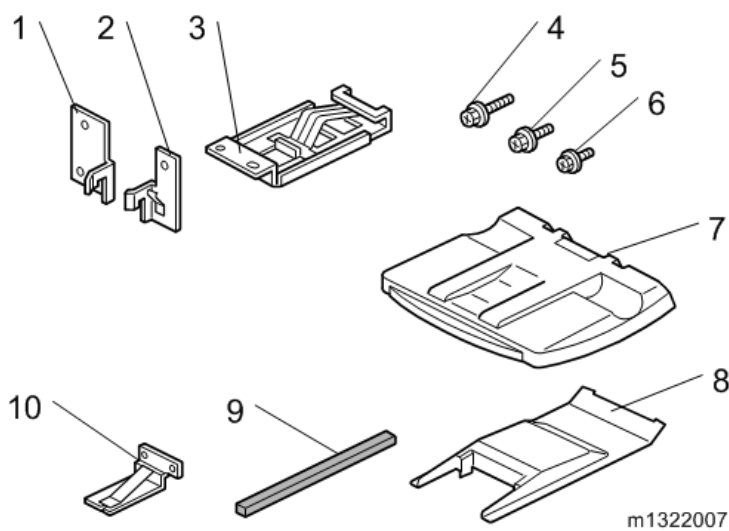

## 2.6.2 INSTALLATION PROCEDURE

### ⚠ CAUTION

- Unplug the main machine power cord before starting the following procedure.

If this finisher is installed on this machine, the following options must be installed before installing this finisher.

- Bridge Unit (D634)
- Paper Feed Unit (D580) or LCIT (D581)

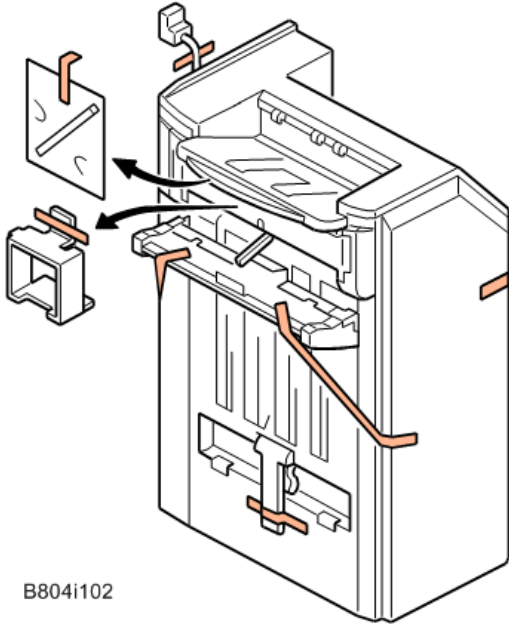

1. Unpack the finisher and remove all tapes and packing materials from the finisher.

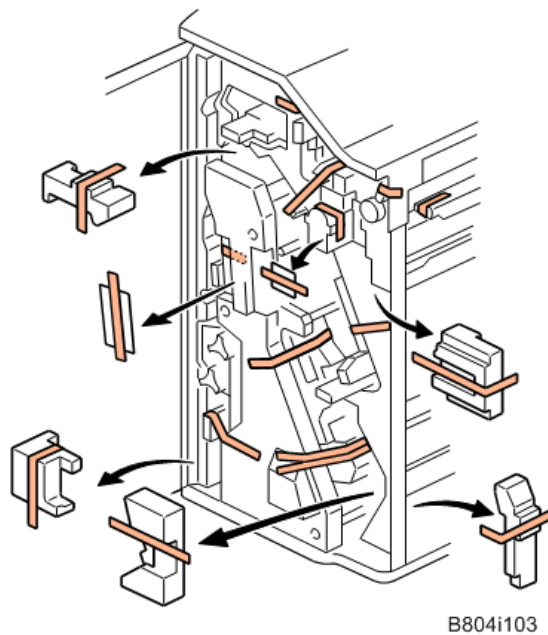

2. Open the front door, and then remove all tapes and packing materials from the inside of the finisher.

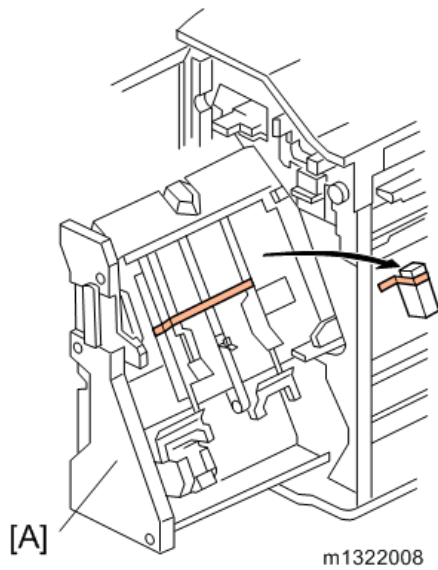

3. Pull out the jogger unit [A], and then remove all tapes and retainers.

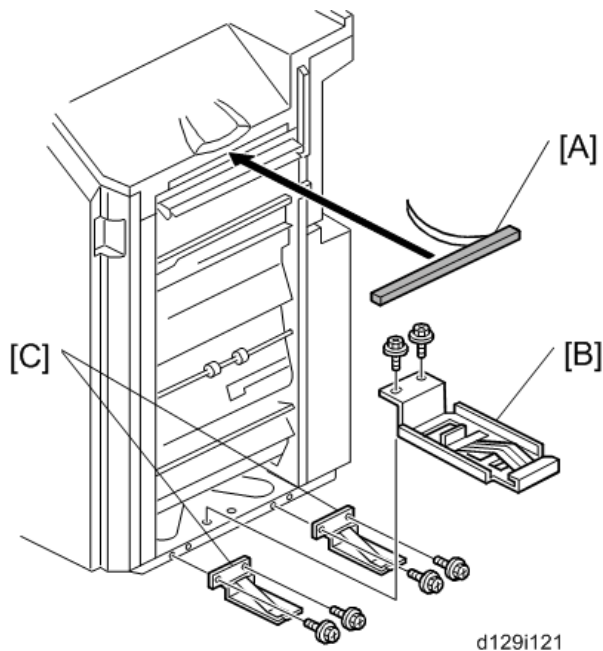

4. Attach the cushion [A] to the finisher.

**Note**

- Make sure that the cushion is placed within 0 to 1 mm from the edge of the cover.

5. Install the ground plate [B] on the finisher (⚙ x 2; M3 x 6).
6. Install the small ground plates [C] on the finisher (⚙ x 2; M3 x 6 each).



## 3000-sheet Finisher (D636)

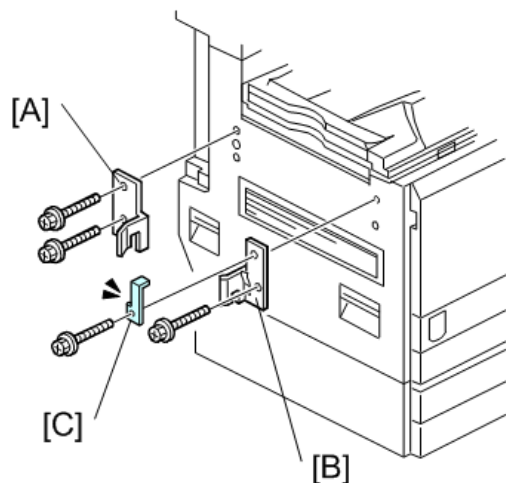

m1322052

7. Attach the rear joint bracket [A] (🔩 x 2; M4 x 14).
8. Attach the front joint bracket [B] and the holder bracket [C] (🔩 x 2; M4 x 14).

### ⬇️ Note

- Holder bracket [C] must be placed outside the front joint bracket [B]. This bracket is provided with the Bridge Unit (D634).

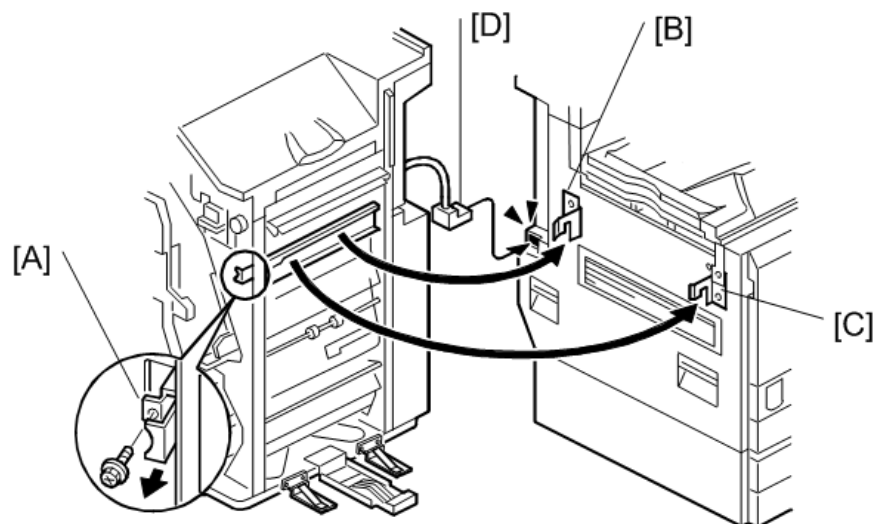

m1322105

9. Pull the lock lever [A] (🔩 x 1).
10. Slowly push the finisher to the left side of the machine, keeping its front door open until the brackets [B] [C] go into their slots.
11. Push the lock lever [A], and then secure it (🔩 x 1).
12. Close the front door of the finisher.
13. Connect the finisher connector [D] to the machine.

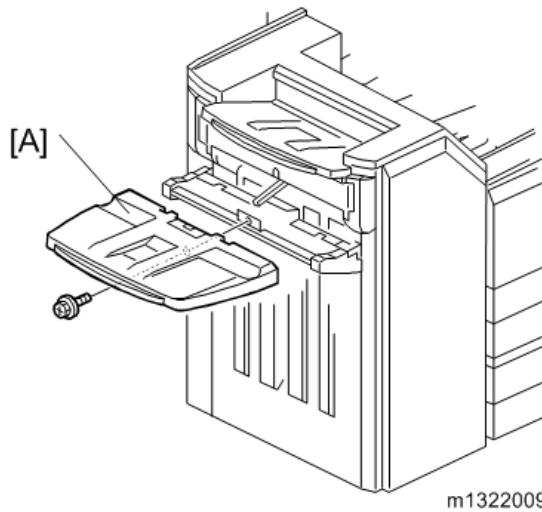

14. Install the upper output tray [A] (1 x 1; M3 x 8).
15. Turn on the main power switch of the machine.
16. Check the finisher operation.

### ***Support Tray Installation***

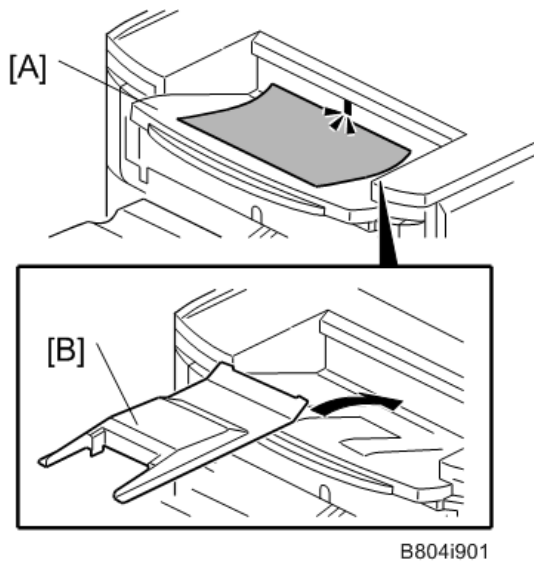

If a stacking problem occurs several times on the upper output tray [A], put the support tray [B] on the tray as shown.

## 2.7 PUNCH UNIT INSTALLATION (D570)

The Punch Unit D570 can be installed in the 3000-Sheet Finisher D636.

### 2.7.1 COMPONENT CHECK

Check the quantity and condition of the components against the following list.

No.	Description	Q'ty
1	Punch-out Waste Unit	1
2	Slide Drive Unit	1
3	Punch Waste Hopper	1
4	Wire harness: short-circuit	1
5	Screws (M3 x 6)	5
6	Side-to-Side Detection Unit	1
7	Punching Unit	1

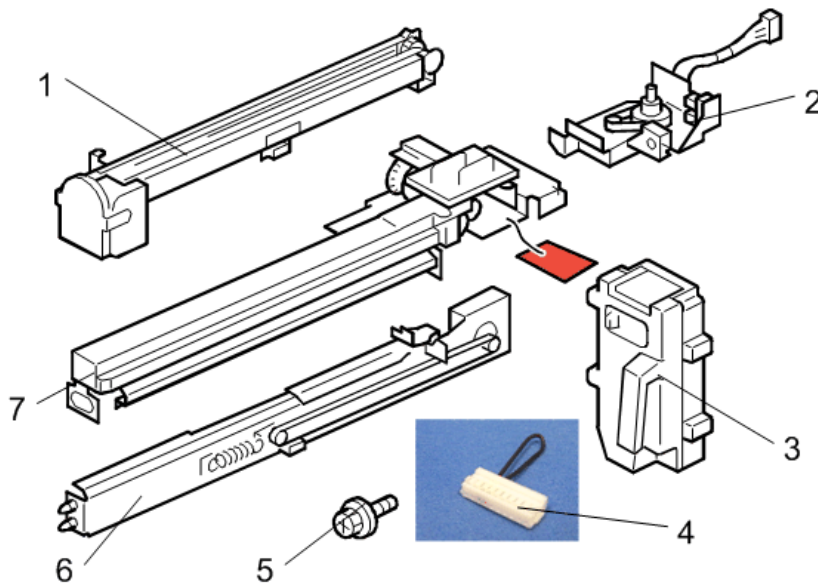

d570i101

### 2.7.2 INSTALLATION PROCEDURE

**⚠ CAUTION**

- Unplug the main machine power cord before starting the following procedure. If the 3000-sheet finisher has been installed, disconnect it and pull it away from the machine.

1. Remove all tapes and shipping retainers.

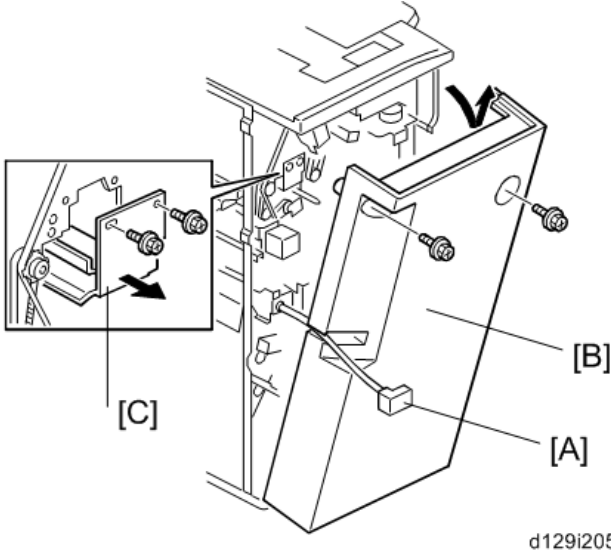

2. If the finisher is connected to the machine, disconnect the power connector [A] and separate the finisher from the machine.
3. Remove the rear cover [B] (⚙ x 2) and open the front door.

**⬇ Note**

- At the base of the back cover, be sure to disconnect the tabs that fasten the cover to the frame.

4. Remove the guide plate [C] (⚙ x 2).

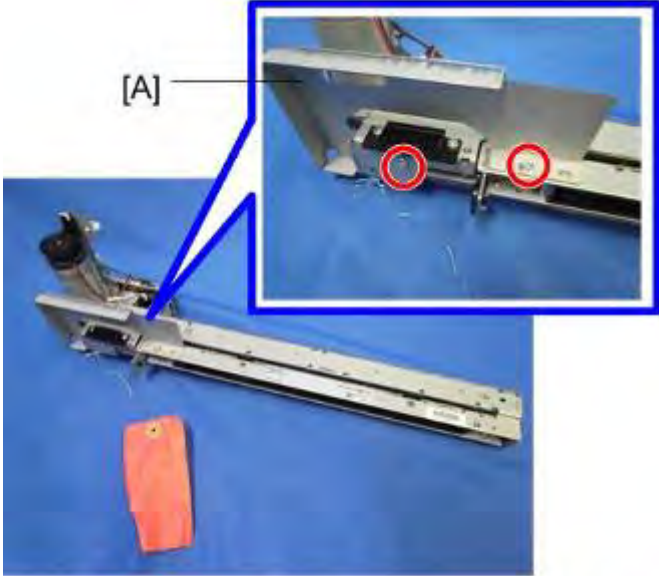

## Punch Unit Installation (D570)

5. Remove the shipping retainer [A] (🔑 x 2) from the punch unit.

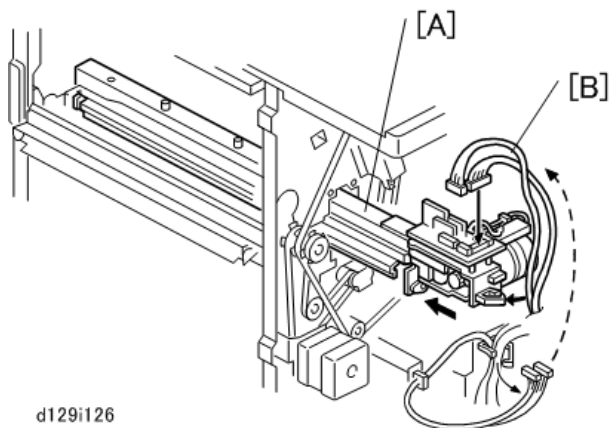

6. Move the punch unit [A] along its rails into the finisher. Make sure that the pin engages correctly at the front and rear.
7. Connect the cables [B] of the finisher to the connectors (CN601 and CN602) on the punch unit board (🔌 x 2, 🖨️ x 1).
  - The cables [B] are coiled and attached to the PCB.

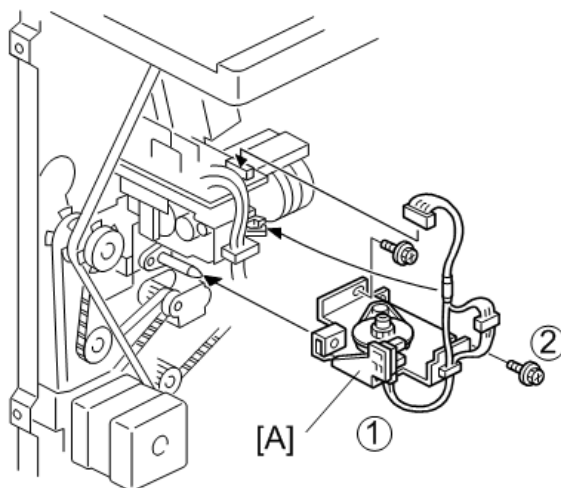

8. Attach the slide drive unit [A] to the finisher and connect it to the punch unit (🔑 x 2, 🖨️ x 1). Push in the slide drive unit at ① when you attach the screw ②.
9. Make sure that the punch unit moves freely and is not blocked by the screws.

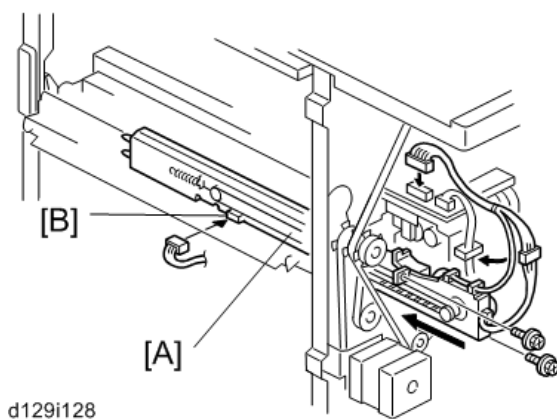

10. Put the side-to-side detection unit [A] in the machine. Make sure that the two pins are engaged correctly at the front.
11. Make sure that the side-to-side detection unit moves smoothly on its rails. If it does not, make sure that the rails are aligned with their grooves.
12. Attach the side-to-side detection unit and connect it at the rear (🔑 x 2, 📁 x 1, 📁 x 1).
13. Pull the short connector out of the connector [B], then connect the cable of the finisher (📁 x 1).

**Note**

- This is the 3-pin connector.

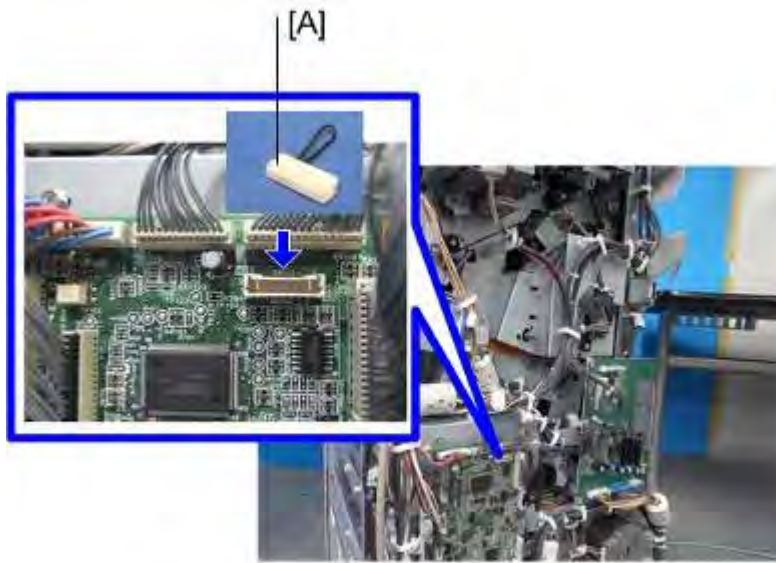

d129i133

14. Connect "Wire harness: short-circuit" [A] to the CN110 connector.

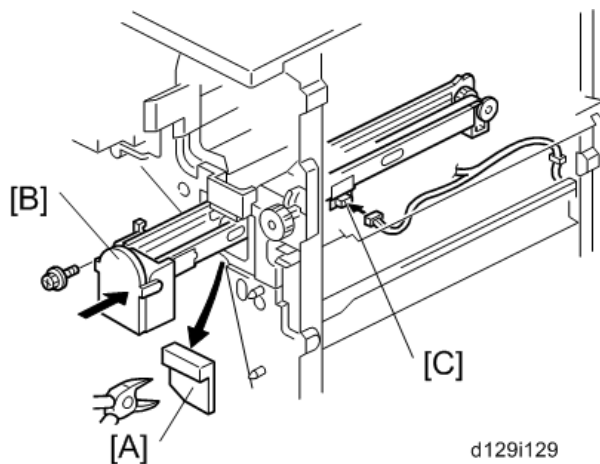

d129i129

15. At the front, use a pair of wire cutters to remove the part [A] of the cover.
16. Install the punch-waste transport unit [B] in the finisher.
17. Make sure that the punch-waste transport unit moves smoothly on its rails. If it does not, make sure that the rails are aligned with the grooves.
18. Remove the short connector from the connector [C].

## Punch Unit Installation (D570)

### Note

- This is the 4-pin connector.

19. Connect the cable to connector [C] and attach the punch-waste transport unit (🗑️ x 1, 🗑️ x 1, 🗑️ x 1).

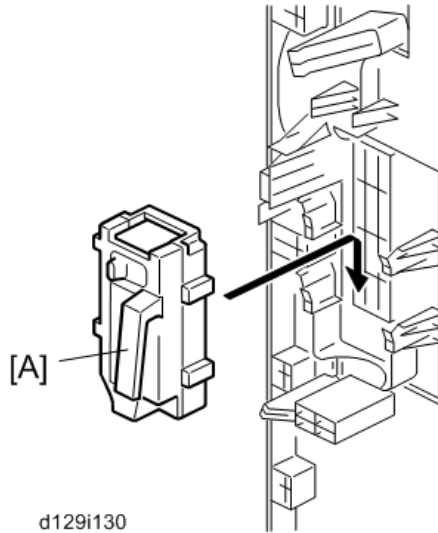

20. Set the hopper [A] in its holder.
21. Reassemble the finisher, and then install it on the main machine.
22. Connect the power cord to the outlet, and then turn the main power switch on.
23. Check the punch unit operation.

## 2.8 OUTPUT JOGGER UNIT INSTALLATION (B703)

### 2.8.1 ACCESSORY CHECK LIST

Check the accessories and their quantities against this list.

No.	Description	Q'ty
1	Jogger Unit	1
2	Tapping Screws M3x6	2

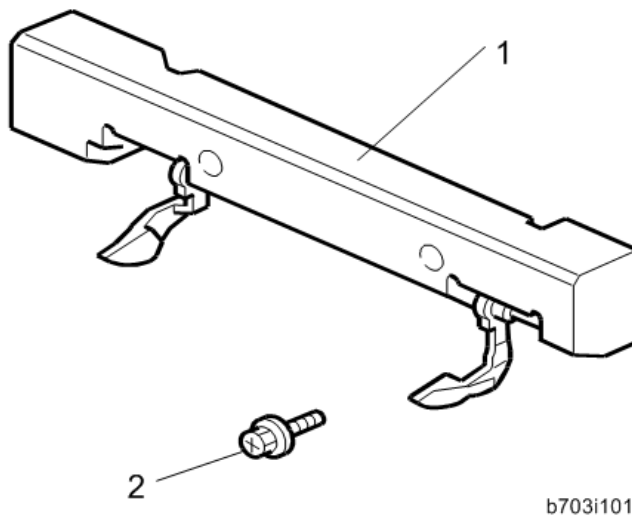

### 2.8.2 INSTALLATION PROCEDURE

The Output Jogger Unit B703 is installed only on the 3000-Sheet Finisher D636.

#### **⚠ WARNING**

- Always switch the machine off and unplug the machine before doing any of the following procedures.
1. Turn the main machine switch off.
  2. Disconnect the finisher from the main frame.



## Output Jogger Unit Installation (B703)

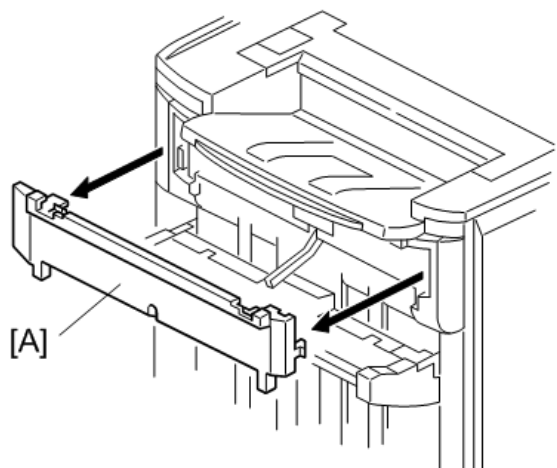

m1322010

3. Use the flat head of a screwdriver to remove the left upper cover [A].

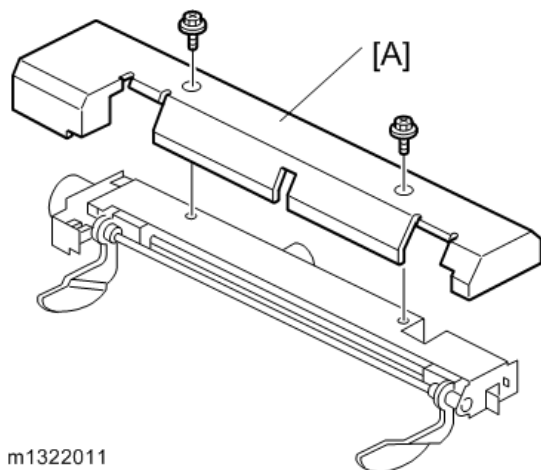

m1322011

4. Remove the cover plate [A] (⚙️ x 2). Keep the screws.

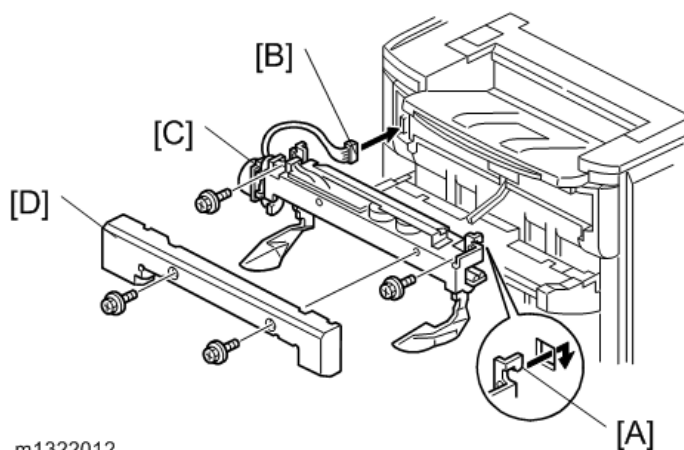

m1322012

5. While holding the jogger unit with the connector on the left, put the hooks on the frame of the jogger unit [A] into the holes in the left and right side of the finisher frame.
6. Connect connector [B] to the socket (⚙️ x 1).
7. Attach the jogger unit [C] to the finisher (⚙️ x 2).
8. Reattach the jogger unit cover [D] to the jogger unit (⚙️ x 2).

## 2.9 TRAY HEATER

### 2.9.1 INSTALLATION PROCEDURE

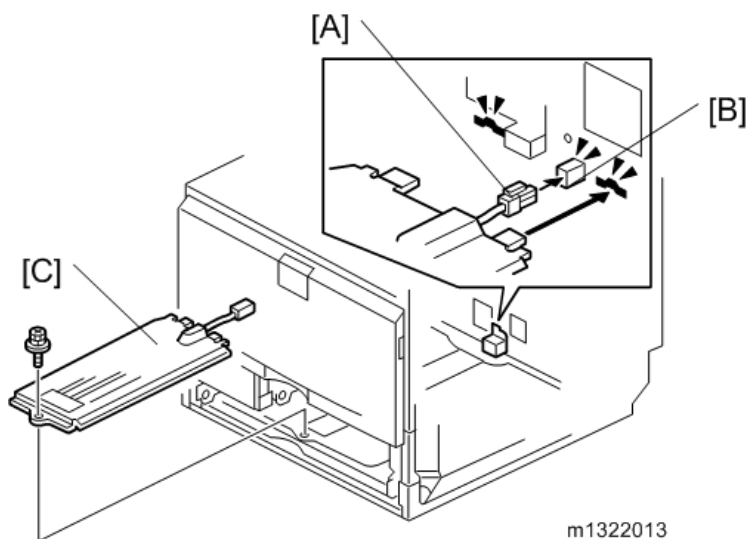

1. Remove trays 1 and 2 from the machine.
2. Connect the connector [A] of the heater to the connector [B] of the main machine.
3. Install the heater [C] inside the machine (⚙ x 1).



4. Remove the connector cover [A] (⚙ x 1).

## Tray Heater



m1322015

5. Release the heater relay connector [A] (🔌 x 1).
6. Connect the heater relay connector to the connector [B] (front side) of the main frame (🔌 x 1).
7. Reassemble the machine.

## 2.10 TRAY HEATER (OPTIONAL PAPER FEED UNIT)

### 2.10.1 COMPONENT CHECK

No.	Description	Q'ty	For this model
1	Tray heater	1	Yes
2	On-standby decal	1	Not used
3	Harness 2	1	Not used
4	Harness 1	1	Yes
5	Screw M4 x 10	2	Yes
-	Installation procedure	1	Yes

Installation

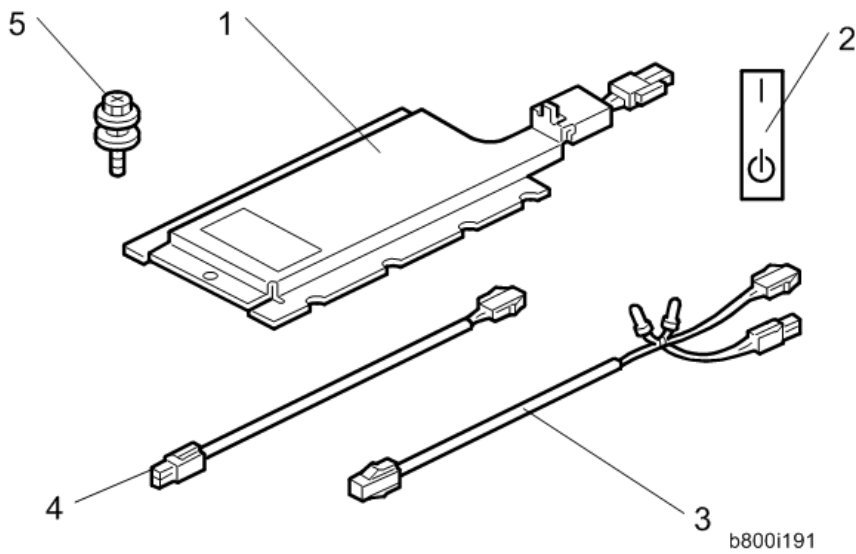

## 2.10.2 INSTALLATION PROCEDURE

### ⚠ CAUTION

- Unplug the machine power cord before starting the following procedure.

#### ***For installing the tray heater in the D580 (Two-tray paper feed unit)***

1. Pull out the two trays from the optional paper feed unit.

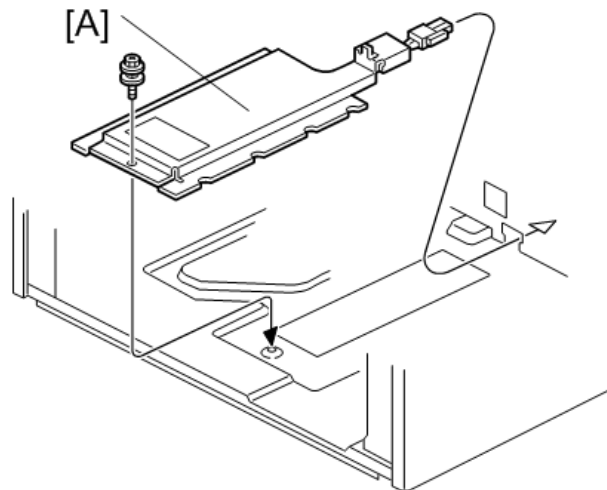

2. Install the tray heater [A] in the optional paper feed unit (🔩 x 1).
3. Pull out tray 2 from the mainframe.

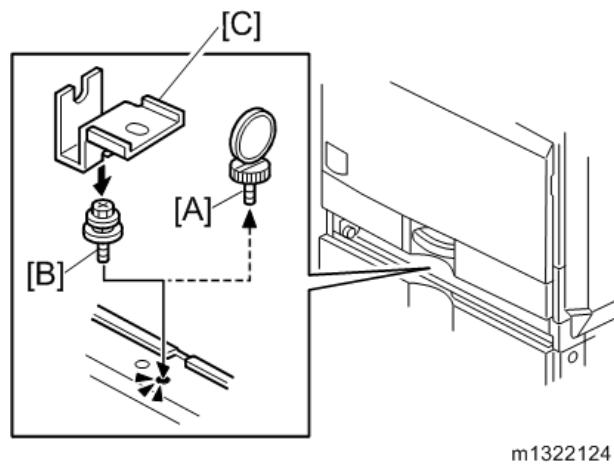

4. Replace the shoulder screw [A] with the washer screw [B], using the securing bracket [C] (🔩 x 1).

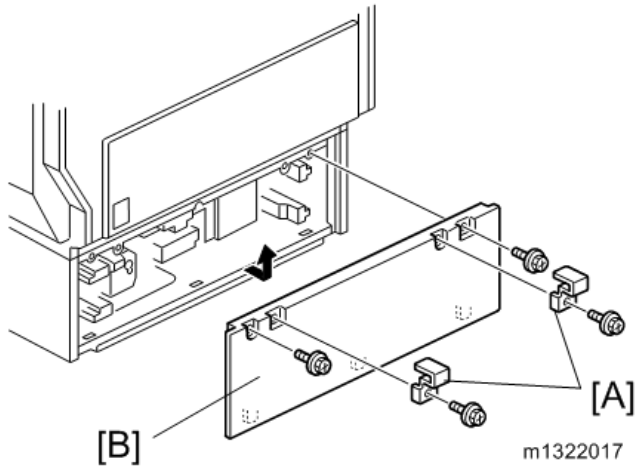

5. Remove the two securing brackets [A] (🔧 x 1 each), and then the rear cover [B] of the optional paper feed unit (🔧 x 2).

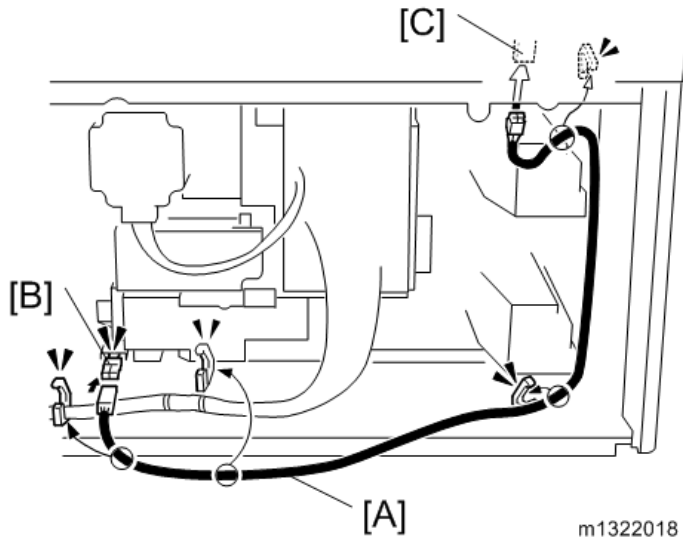

6. Connect the harness [A] to the connector [B] of the tray heater.
7. Route the harness [A] as shown and clamp it with four clamps (🔧 x 4).
8. Connect the harness [A] to the connector [C] of the mainframe.



9. Remove the connector cover [A] (🔧 x 1).

## Tray Heater (Optional Paper Feed Unit)

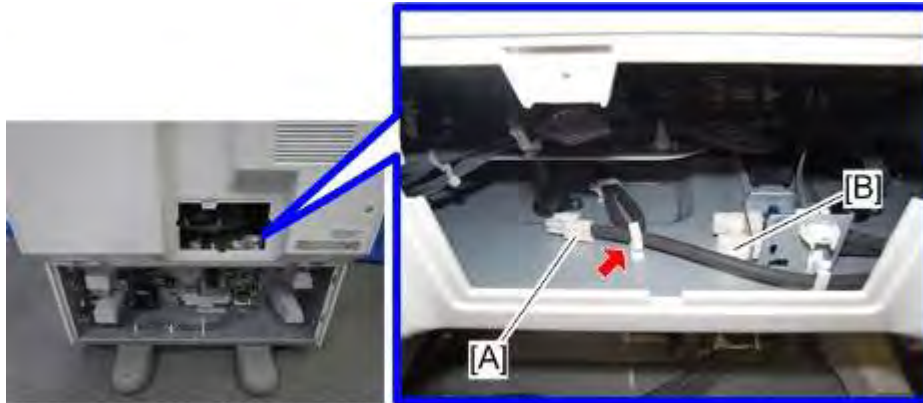

m1322020

10. Release the optional heater relay connector [A] (🔌 x 1).
11. Connect the optional heater relay connector to the connector [B] (rear side) of the main frame (🔌 x 1).
12. Reassemble the mainframe and optional paper feed unit.

### ***For installing the tray heater in the D581 (LCT)***

1. Remove the rear cover of the mainframe (🔩 x 6).
2. Pull out the LCT drawer.

#### ⬇ Note

- If the right tray comes out with the left tray, push the right tray into the LCT.

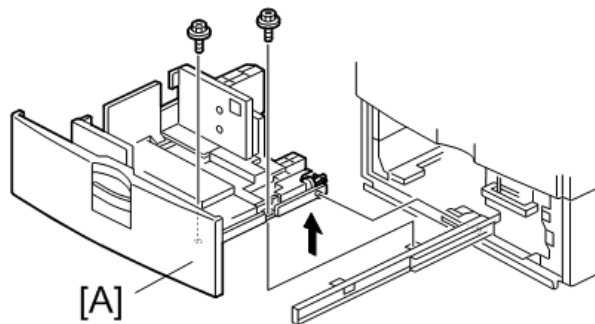

m1322021

3. Left tray [A] (🔩 x 2)

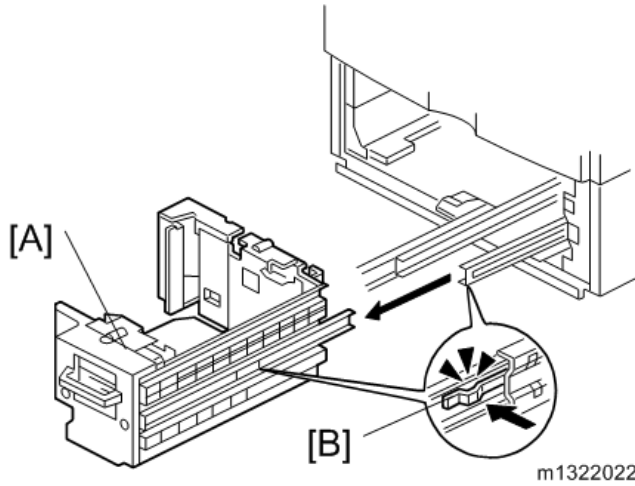

4. Remove the right tray [A] while pressing down the stopper [B].

**Note**

- When reinstalling the right tray, set the right tray on the guide rail and carefully push the tray in, making sure to keep the tray level.

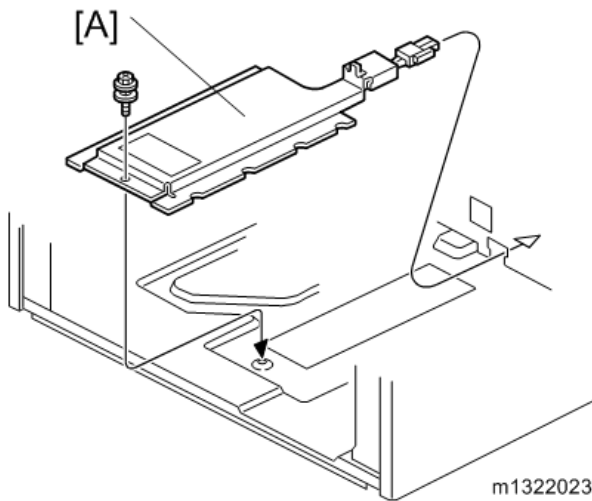

5. Install the tray heater [A] in the optional LCT (1 x 1).
6. Pull out tray 2 from the mainframe.

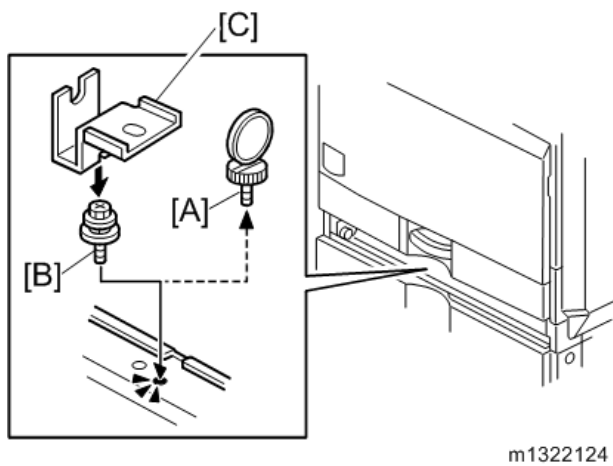



## Tray Heater (Optional Paper Feed Unit)

7. Replace the shoulder screw [A] with the washer screw [B], using the securing bracket [C] (🔩 x 1).

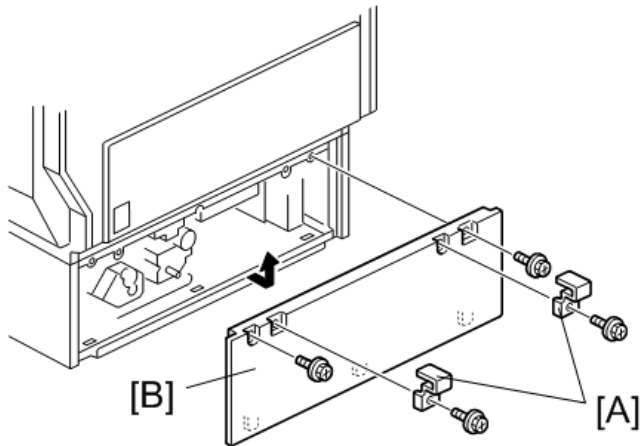

m1322024

8. Remove the two securing brackets [A] (🔩 x 1 each), and then the rear cover [B] of the optional LCT (🔩 x 2).

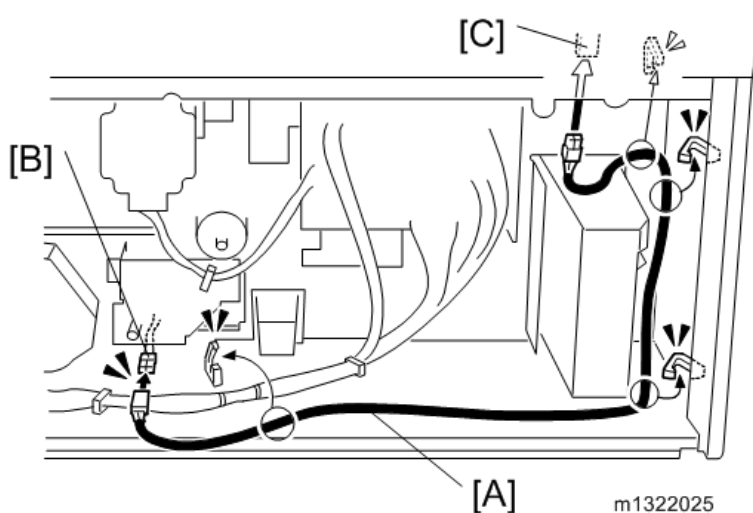

m1322025

9. Connect the harness [A] to the connector [B] of the tray heater.
10. Route the harness [A] as shown and clamp it with four clamps (🔧 x 4).
11. Connect the harness [A] to the connector [C] of the mainframe.
12. Reassemble the rear cover of the optional LCT.



m1322026

13. Remove the connector cover [A] (🔑 x 1).

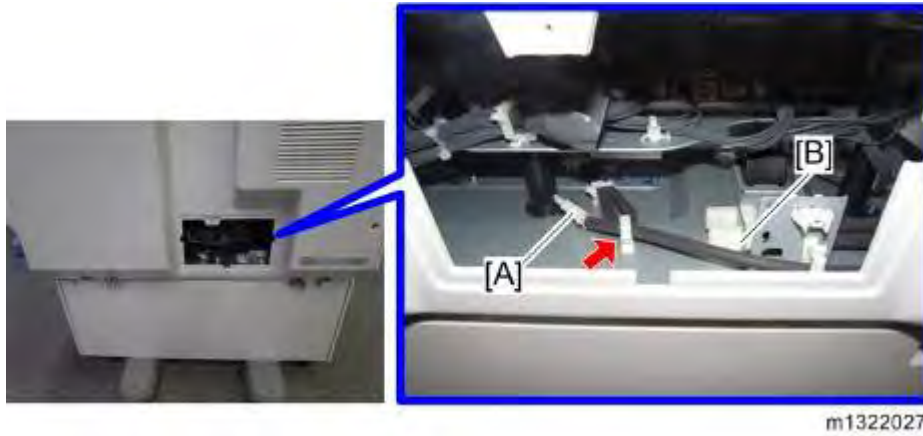

14. Release the optional heater relay connector [A] (🔑 x 1).
15. Connect the optional heater relay connector to the connector [B] (rear side) of the main frame (🔑 x 1).
16. Reassemble the mainframe and optional LCT.

Installation

## 2.11 EXTERNAL USB KEYBOARD INSTALLATION

### 2.11.1 INSTALLATION PROCEDURE

Customers can use an external USB keyboard when the software keyboard is shown on the operation panel, if an external USB keyboard is connected to the USB port at the side of the operation panel or the controller box USB port.

If customers would like to use an external USB keyboard, execute the following steps to enable this feature.

1. Connect the external keyboard to the USB port at the right side of the operation panel or the controller box USB port.

**Note**

- The external keyboard that is available in this machine is principally for the Windows OS. However, no compatibility check is done, and there is no warranty.

2. Enter the SP mode.
3. Select "Engine" SP.
4. Select "5075 USB Keyboard".

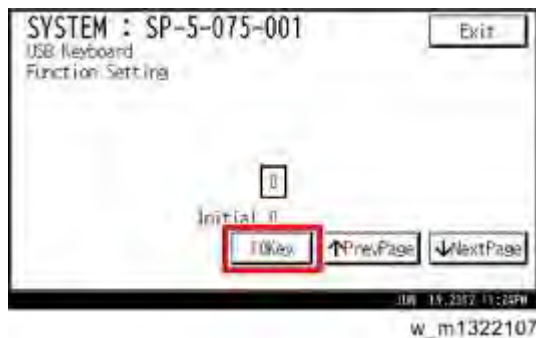

5. Press [10Key] to open the number entry screen.



6. Enter "1" then press [OK]. This switches the USB Keyboard feature on.
7. Exit the SP mode and turn the main power off and on.

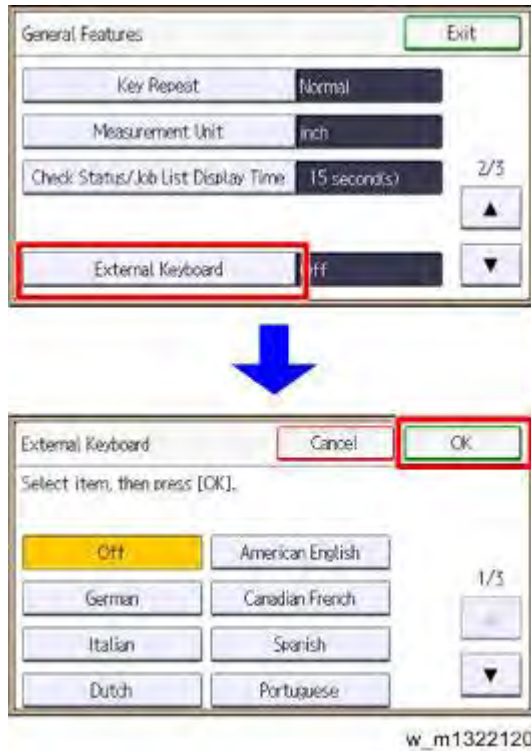

8. Select a language type for the external USB keyboard with [User Tools] > [System Settings] > [General Features] > [External Keyboard].
9. Press [OK] to set it.
10. Turn the main power off and on.

## 2.12 CONTROLLER OPTIONS

### 2.12.1 OVERVIEW

This section describes the installation procedures for controller options for M132 series machines.

#### *Controller Options*

No.	Item	Slots
G874	Gigabit Ethernet Board Type A (EU only)	Board Slot. Only one of these boards can be installed at one time.
M394	Gigabit Ethernet Board Type C (NA only)	
M344	IEEE 802.11 a/g Interface Unit Type L -or- IEEE 802.11g Interface Unit Type M -or- IEEE 802.11g Interface Unit Type P	
B679	IEEE 1284 Interface Board Type A	
M416	IPDS Unit Type 8300	
D640	VM Card Type U	SD Card Slot 1 (Upper Slot)
M416	SD Card for NetWare printing Type N	SD Card Slot 1 (Upper Slot)
D641	SD Card for Fonts Type D (EU only)	SD Card Slot 1 (Upper Slot)
M416	Hard Disk Drive Option Type 8300	Controller Board
D594	Memory Unit Type L 512MB	

#### Note

- If more than one SD card application is required, the applications must be moved to one SD card with SP5873-1. For more details about merging applications from SD card Slot 2 (Lower Slot) to Slot 1 (Upper Slot), see “Application Merge” in this section.

**Board, SD Card Slots**

The machine controller box has one board slot and two SD card slots.

Only one interface board option can be installed.

Only two SD cards are available for applications and maintenance.

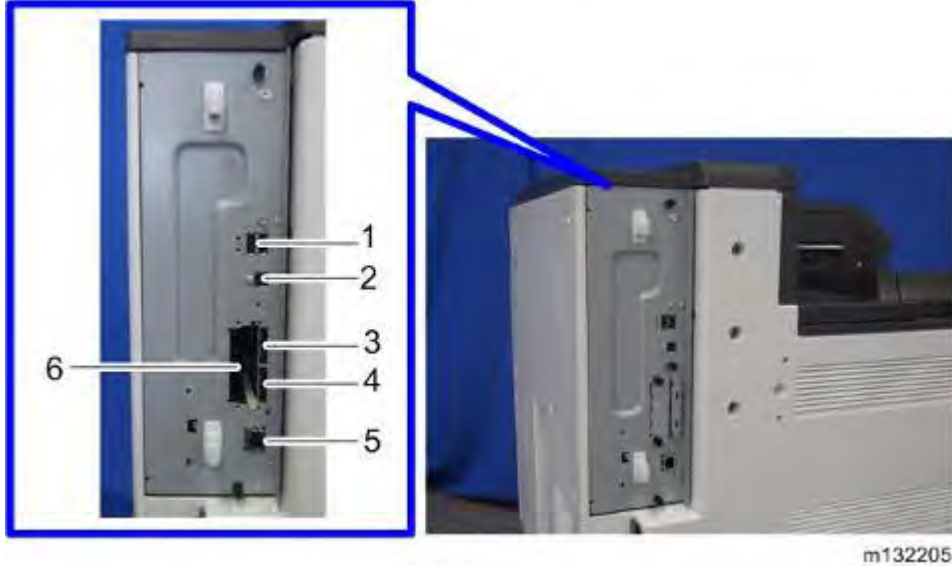

Installation

No.	Name	Description
1	USB-A	Both USB slots are used for a card authentication device.
2	USB-B	Built-in for connection of USB devices (USB 2.0)
3	SD Card Slot 1 (Upper Slot)	For options provided on SD cards. The application SD card can be installed in Slot 1 (Upper Slot). If two or more applications are to be used, move the applications to the same SD card with SP5873-1.
4	SD Card Slot 2 (Lower Slot)	For servicing.
5	Ethernet	Standard LAN connection point. 100BASE-TX/10BASE-T LAN <ul style="list-style-type: none"> <li>▪ Orange LED: Lights when 100BASE-TX is operating.</li> <li>▪ Green LED: Lights when 10BASE-TX is operating.</li> </ul>
6	Board Slot	Optional interface boards are installed here.

**Note**

- Only two SD Card slots are available for applications.
- To install more applications, they must be moved onto one SD Card.
- **Board Slot:**  
The following optional interface boards are available. There is only one board slot so only one can be installed.

No.	Interface Board
G874	Gigabit Ethernet Board Type A (EU)
M394	Gigabit Ethernet Board Type C (NA)
M344	IEEE 802.11a/g Interface Unit Type L -or- IEEE 802.11g Interface Unit Type M -or- IEEE 802.11g Interface Unit Type P
B679	IEEE 1284 Interface Board Type A

**Note**

- Only one of these boards can be installed at one time.
- **SD Card Slot:**  
The following options are provided on SD cards.
  - Two SD card slots are available.
  - Options provided on SD cards should be installed in Slot 1 (Upper Slot). If more than one application is required, applications can be moved onto one SD card with SP5873-1.

No.	SD Card Applications
M416	IPDS Unit Type 8300
M416	SD card for NetWare printing Type N
D641	SD Card for Fonts Type D (EU only)
D640	VM Card Type U

## 2.12.2 APPLICATION MERGE

### Overview

This machine has two SD card slots only. However, more than two optional applications are supplied for this machine. Always keep SD card Slot 2 (Lower Slot) vacant for servicing. Because of this, SD card merge is required if a customer wants to use many applications.

The service program "SD Card Appli Move" (SP5-873) lets you to copy application programs from one SD card to another SD card.

You can move application programs from Slot 2 (Lower Slot) to Slot 1 (Upper Slot).

### Important Notes about SD Card Appli Move

1. Consider the following limitations when you try to merge SD cards.  
The destination SD card should have the largest memory size of all the application SD cards.  
Refer to the following table for the memory size of each SD card.

SD Card Options	SD Card Size
IPDS Unit Type 8003	128 MB
SD card for NetWare printing Type N	128 MB
VM Card Type U	256 MB
SD Card for Fonts Type D (EU only)	128 MB

2. The data necessary for authentication is transferred with the application program from an SD card to another SD card. Authentication fails if you try to use the SD card after you copy the application program from one card to another card.
3. Do not use the SD card if it has been used by the user on the computer. Normal operation is not guaranteed when such an SD card is used.

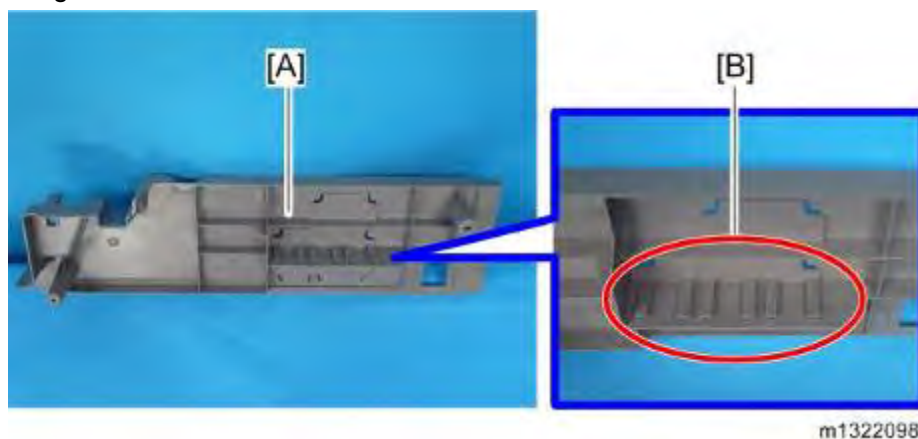



- Remove the lower inner cover [A] (☛ p.4-3 "Front Door, Upper and Lower Inner Cover"), and then keep the SD card in the place [B] after you move the application program from one card to another card. This is done for the following reasons:
  - The SD card can be the only proof that the user is licensed to use the application program.
  - You may need to check the SD card and its data to solve a problem in the future.
- Before storing the card from which an application has been copied, label it carefully so that you can identify it easily if you need to do the undo procedure later.

### **Move Exec**

The menu "Move Exec" (SP5-873-001) lets you copy application programs from the original SD card to another SD card.

#### **★ Important**

- Do not turn ON the write protect switch of the system SD card or application SD card on the machine. If the write protect switch is ON, a download error (e.g. Error Code 44) occurs during a firmware upgrade or application merge.**
- Turn the main switch off.



- Remove the SD card slot cover [A] (☛ x 1).
- Make sure that an SD card is in SD Card Slot 1 (Upper Slot). The application program is copied into this SD card.
- Insert the SD card (having stored the application program) to SD Card Slot 2 (Lower Slot). The application program is copied from this SD card.
- Turn the main switch on.
- Start the SP mode.
- Select SP5-873-001 "Move Exec."
- Touch "Execute".
- Follow the messages shown on the operation panel.
- Turn the main switch off.
- Remove the SD card from SD Card Slot 2 (Lower Slot).

12. Turn the main switch on.
13. Enter the printer user mode. Then print the configuration page.  
Check that the application programs run normally.
  - User Tools > Printer Features > List / Test Print > Configuration Page
 All installed options are shown in the "System Reference" column.
14. Turn the main switch off again, and then reattach the SD card slot cover.

### **Undo Exec**

The menu "Undo Exec" (SP5-873-002) lets you copy back application programs from an SD card to the original SD card. You can use this program when, for example, you have mistakenly copied some programs by using Move Exec (SP5-873-001).

#### **★ Important**

- **Do not turn ON the write protect switch of the system SD card or application SD card on the machine. If the write protect switch is ON, a download error (e.g. Error Code 44) occurs during a firmware upgrade or application merge.**
1. Turn the main switch off.
  2. Insert the original SD card in SD Card Slot 2 (Lower Slot). The application program is copied back into this card.
  3. Insert the SD card (having stored the application program) to SD Card Slot 1 (Upper Slot).  
The application program is copied back from this SD card.
  4. Turn the main switch on.
  5. Start the SP mode.
  6. Select SP5-873-002 "Undo Exec."
  7. Touch "Execute".
  8. Follow the messages shown on the operation panel.
  9. Turn the main switch off.
  10. Remove the SD card from SD Card Slot 2 (Lower Slot).

#### **↓ Note**

- This step assumes that the application programs in the SD card are used by the machine.
11. Turn the main switch on.
  12. Make sure that the machine can recognize the option.
  13. Enter the printer user mode. Then print the configuration page.  
Check that the application programs run normally.
    - User Tools > Printer Features > List / Test Print > Configuration Page
 All installed options are shown in the "System Reference" column.
  14. Turn the main switch off again, and then reattach the SD card slot cover.



# **PREVENTIVE MAINTENANCE**



---

## 3. PREVENTIVE MAINTENANCE

### 3.1 PM TABLES

See "Appendices" for the following information:

- PM Tables



# **REPLACEMENT AND ADJUSTMENT**





---

## 4. REPLACEMENT AND ADJUSTMENT

### 4.1 GENERAL CAUTIONS

#### CAUTION

- To avoid damage to the transfer belt, drum, or development unit when it is removed or re-installed, never turn off power switch while electrical components are active.

#### CAUTION

- Turn off the main power switch and unplug the machine before attempting any of the procedures in this section.

#### 4.1.1 LASER UNIT

1. Do not loosen the screws that secure the LD drive board to the laser diode casing. Doing so would throw the LD unit out of adjustment.
2. Do not adjust the variable resistors on the LD unit, as they are adjusted in the factory.
3. The polygon mirror and F-theta lenses are very sensitive to dust. Do not open the optical housing unit.
4. Do not touch the glass surface of the polygon mirror motor unit with bare hands.
5. After replacing the LD unit, do the laser beam pitch adjustment.

#### 4.1.2 USED TONER

Dispose of used toner in accordance with local regulations. Never throw toner into an open flame, for toner dust may ignite.

## 4.2 SPECIAL TOOLS AND LUBRICANTS

### 4.2.1 SPECIAL TOOLS

Part Number	Description	Q'ty
A2309003	Adjustment Cam – Laser Unit	1
A2309004	Positioning Pin – Laser Unit	1
B6455010	SD Card 128MB	1
B6455020	SD Card 1GB	1
G0219350	Loop Back Connector: Parallel *1	1
B6795100	Plug - IEEE1284 Type C	1

\*1 “Loop Back Connector: Parallel” requires “Plug - IEEE1284 Type C”.

#### ↓ Note

- A PC (Personal Computer) is required for creating the Encryption key file on an SD card when replacing the controller board for a model in which HDD encryption has been enabled.

### 4.2.2 LUBRICANTS

Part Number	Description	Q'ty
A2579300	Grease Barrierta – S552R	1
52039502	Silicone Grease G501	1

## 4.3 EXTERIOR COVERS

### 4.3.1 FRONT DOOR, UPPER AND LOWER INNER COVER

1. Left Cover (🔑 p.4-4)

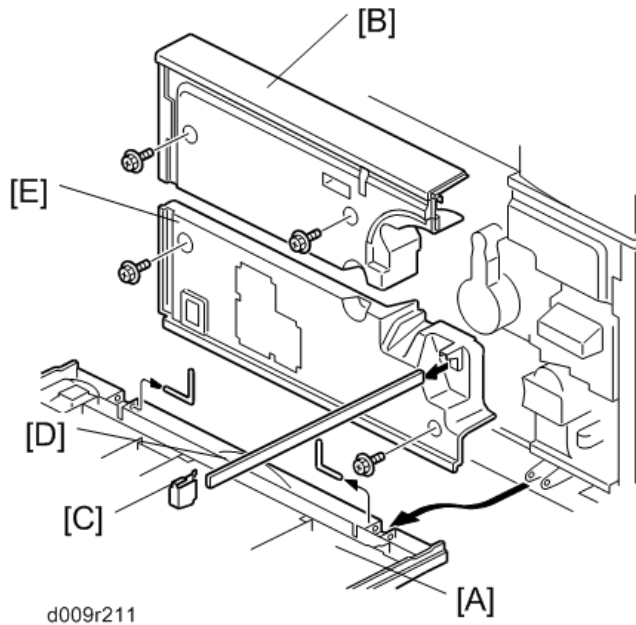

2. Open and remove the front door [A] (pin x 2).

#### ***Upper Inner Cover***

1. Open the front door [A].
2. Upper inner cover [B] (🔑 x 2)

#### ***Lower Inner Cover***

1. Remove the front door [A] (pin x 2)
2. Shield glass cover [C]
3. Shield glass [D] (🔑 x 2)
4. Lower inner cover [E]

### 4.3.2 LEFT COVER

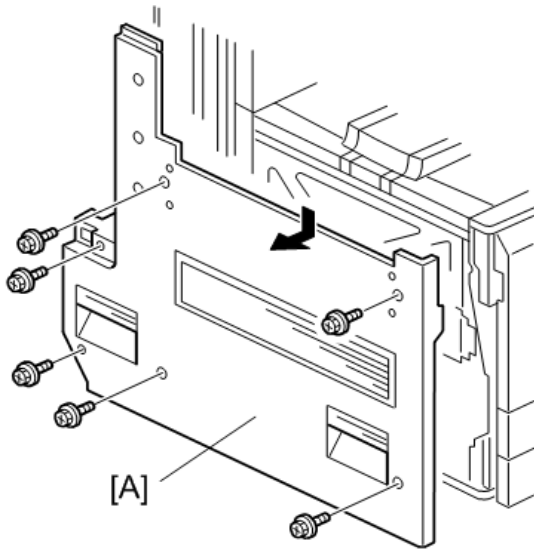

g179r201

1. Left cover [A] (🔩 x 6)

### 4.3.3 REAR COVER

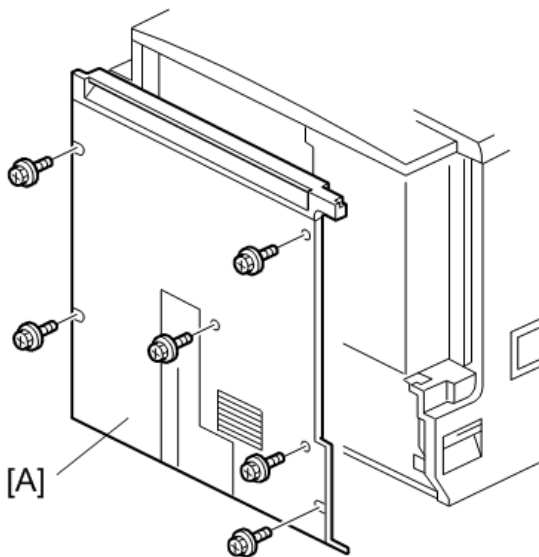

g179r106

1. Rear cover [A] (🔩 x 6)

### 4.3.4 RIGHT REAR COVER

1. Rear cover (🔑 p.4-4)
2. Top right and top rear cover (🔑 p.4-6)



m1322069

3. Open the right door [A].



m1322070

4. Right rear cover [A] (🔑 x 4)

Replacement  
and  
Adjustment

### 4.3.5 TOP RIGHT AND TOP REAR COVER

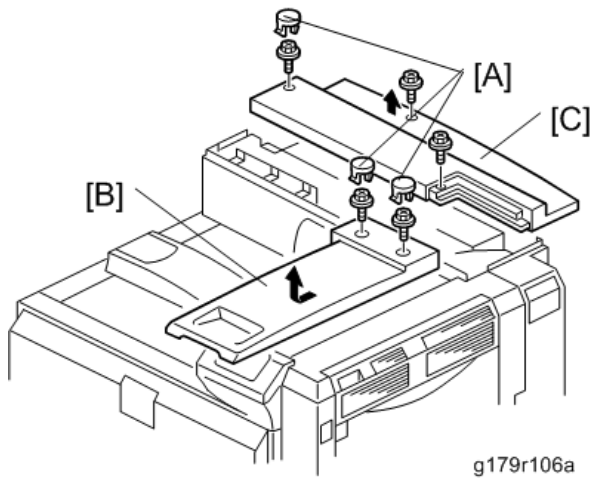

1. Remove the screw caps [A].
2. Top right cover [B] (🔩 x 2)
3. Top rear cover [C] (🔩 x 3)

### 4.3.6 OPERATION PANEL



1. Open the right door [A].
2. Top right cover (🔩 p.4-6 "Top Right and Top Rear Cover")

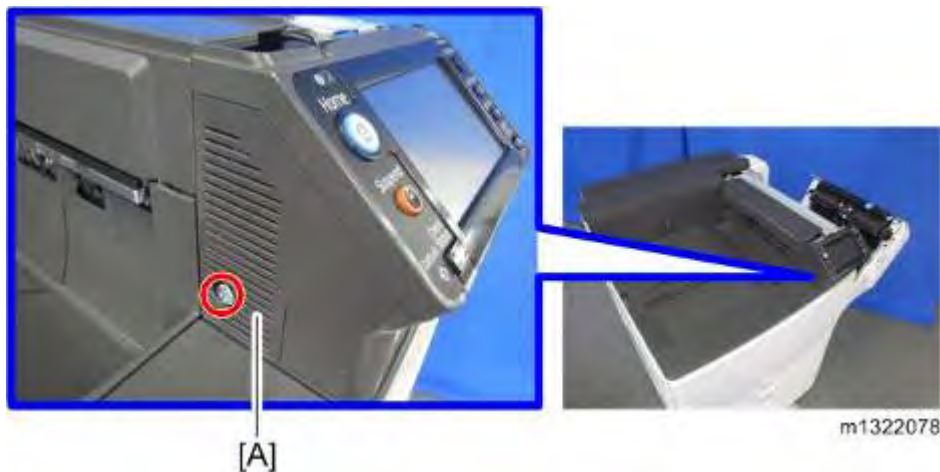

3. Operation panel cover [A] (🔩 x 1)

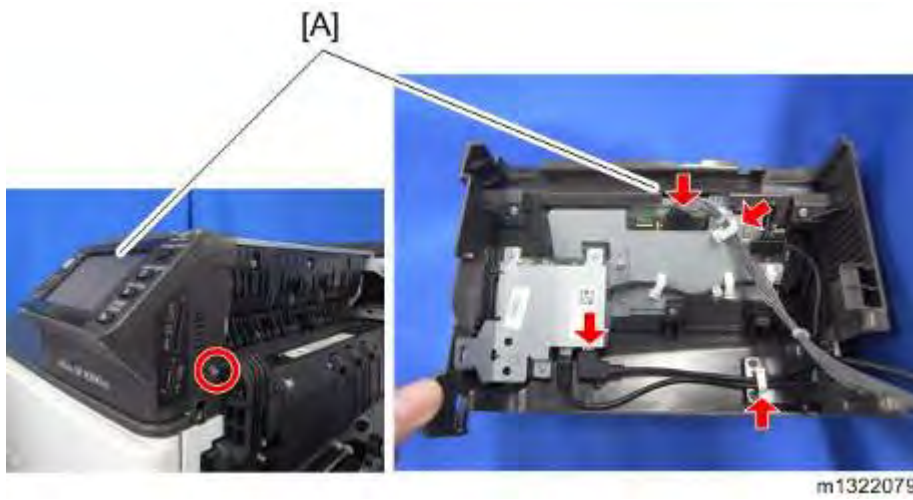

4. Operation panel unit [A] (🔩 x 1, 📎 x 2, 📎 x 2)

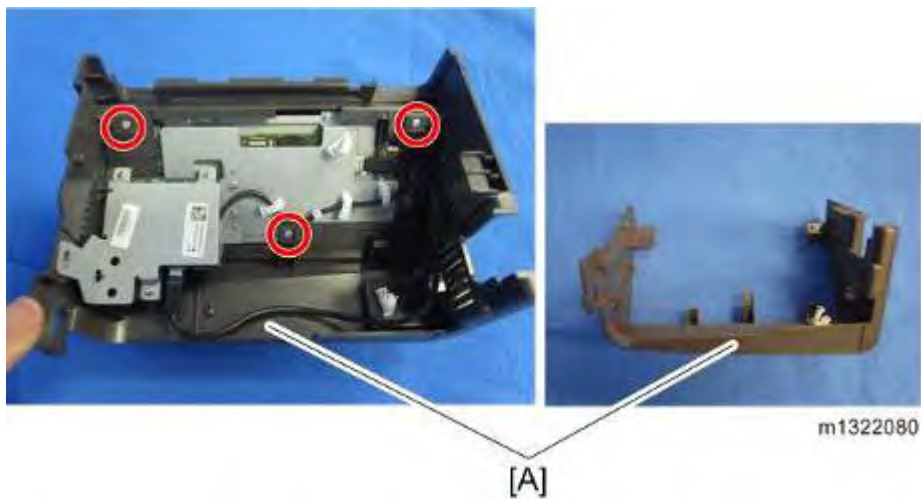

5. Operation panel bracket [A] (small 🔩 x 3)



6. Operation panel [A]

Replacement  
and  
Adjustment



### ***When Installing the New Operation Panel***

Do the touch screen calibration after you replace the operation panel. (☛ p.4-92 "Touch Screen Calibration")

#### **4.3.7 PAPER EXIT COVER**

1. Top right cover (☛ p.4-6 "Top Right and Top Rear Cover")
2. Operation panel unit (☛ p.4-6 "Operation Panel")

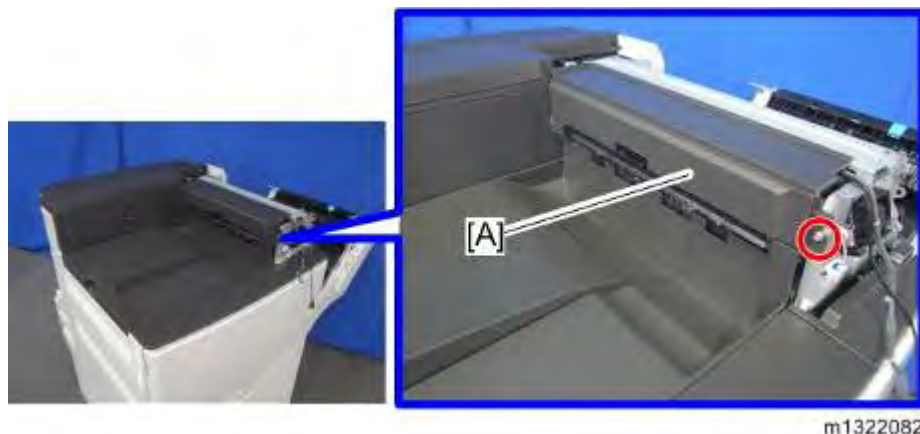

3. Paper exit cover [A] (☛ x 1)

#### **4.3.8 OUTPUT TRAY**

1. Left cover (☛ p.4-4)
2. Upper inner cover (☛ p.4-3 "Front Door, Upper and Lower Inner Cover")
3. Paper exit cover (☛ p.4-8)

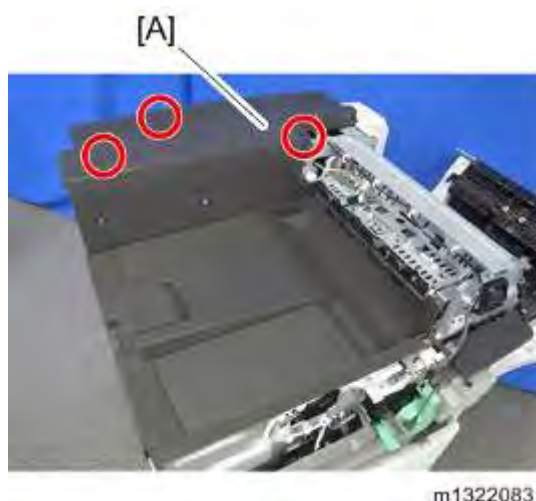

4. Top rear cover [A] (screw cap x 1, ☛ x 3)

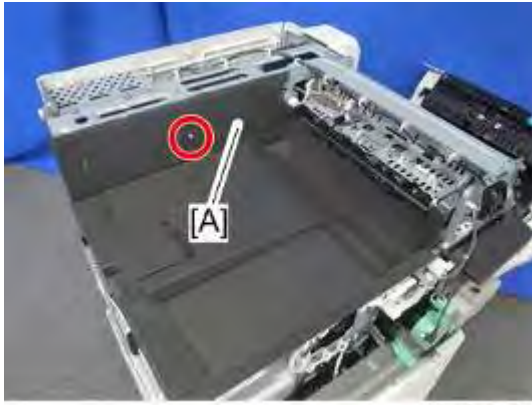

m1322084

- 5. Connector cover [A] (🔑 x 1)

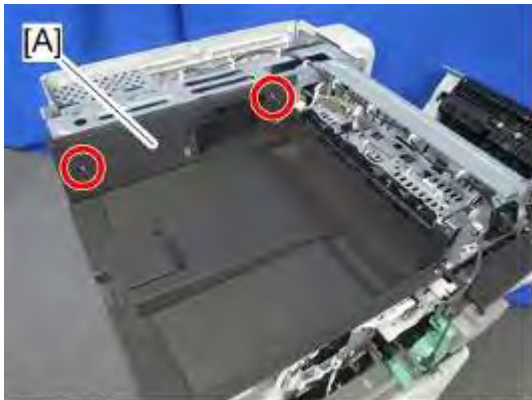

m1322085

- 6. Inner rear cover [A] (🔑 x 2)

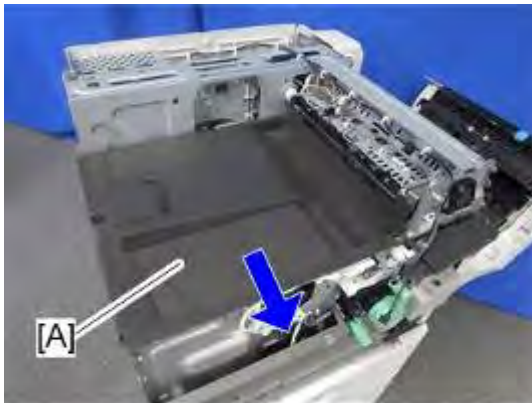

m1322086

- 7. Output tray [A]

Replacement  
and  
Adjustment

## 4.4 LASER UNIT

### **⚠ WARNING**

- Turn off the main power switch and unplug the machine before attempting any of the procedures in this section. Laser beams can seriously damage your eyes.

### 4.4.1 CAUTION DECAL LOCATIONS

Two caution decals are located in the laser section as shown below. (See the next page for removal instructions.)

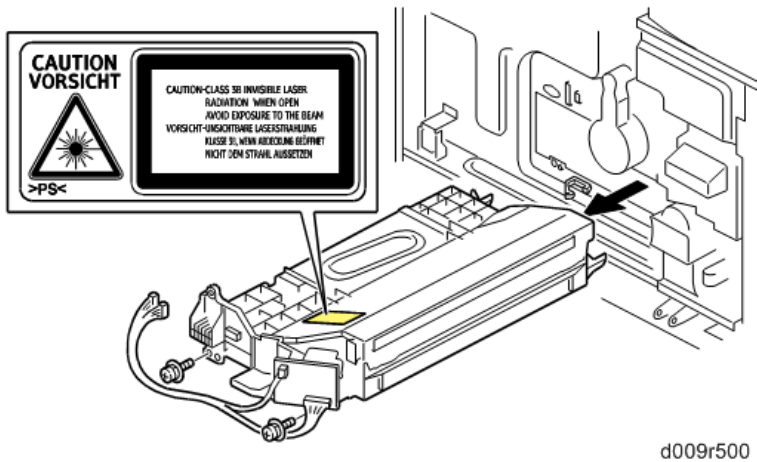

d009r500

## 4.4.2 LASER UNIT

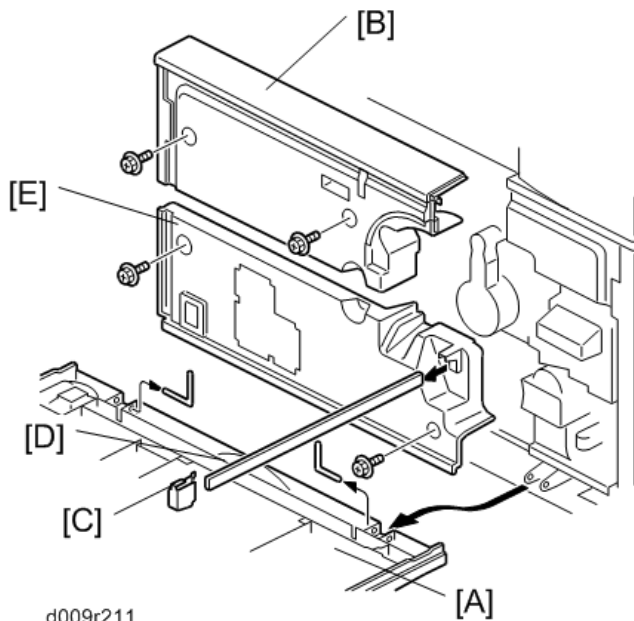

1. Open the front door.
2. Front door [A] (pins x 2)
3. Upper inner cover [B] (⚙️ x 2)
4. Glass cap [C]
5. Shield glass [D]
6. Lower inner cover [E] (⚙️ x 2)

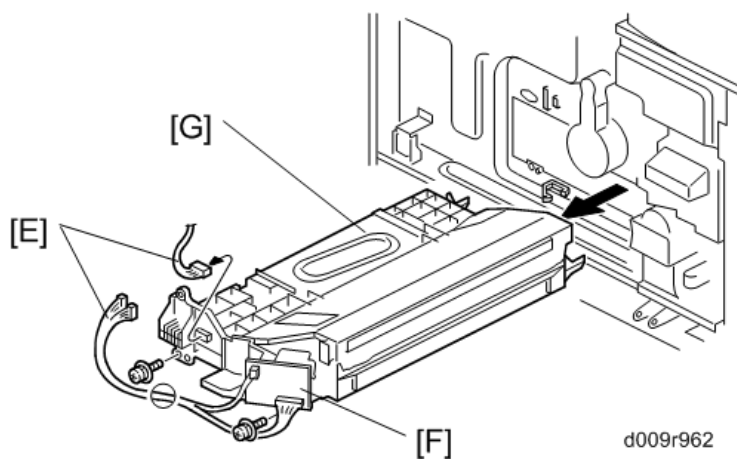

7. Laser unit connectors [E] (⚙️ x 3, ⚙️ x 1)

**★ Important**

- Do not disconnect the harnesses on the LD board [F] unless the LD unit has to be replaced. This board is precisely adjusted in the factory.

8. Laser unit [G] (⚙️ x 2)

**★ Important**

- When sliding out the laser unit, do not hold the LD board. Hold the laser unit.

### 4.4.3 POLYGON MIRROR MOTOR

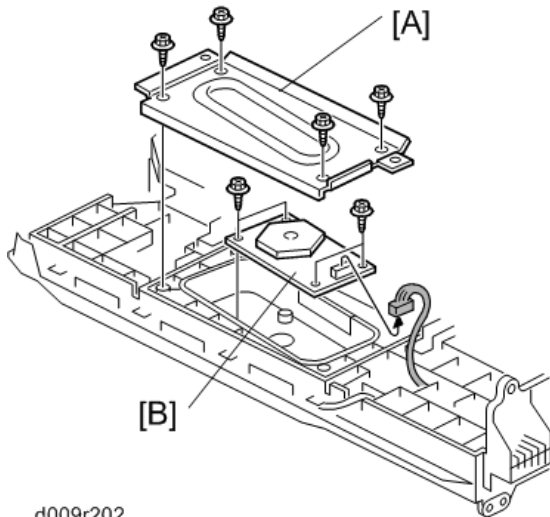

d009r202

1. Laser unit (☛ p.4-11)
2. Laser unit cover [A] (🔩 x 4)
3. Polygon mirror motor [B] (🔩 x 4, 📏 x 1)
4. After replacing the polygon mirror motor, do the image adjustment (☛ p.4-88 "Print Adjustments").

### 4.4.4 LASER SYNCHRONIZATION DETECTOR

1. Laser unit (☛ p.4-11)

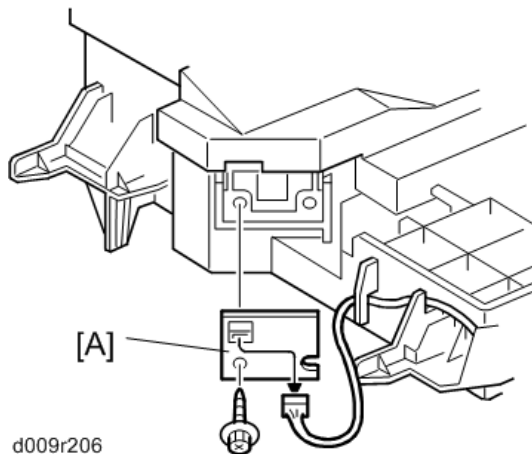

d009r206

2. Laser synchronization detector [A] (🔩 x1, 📏 x1)

## 4.4.5 LD UNIT

1. Laser unit (☞ p.4-11)

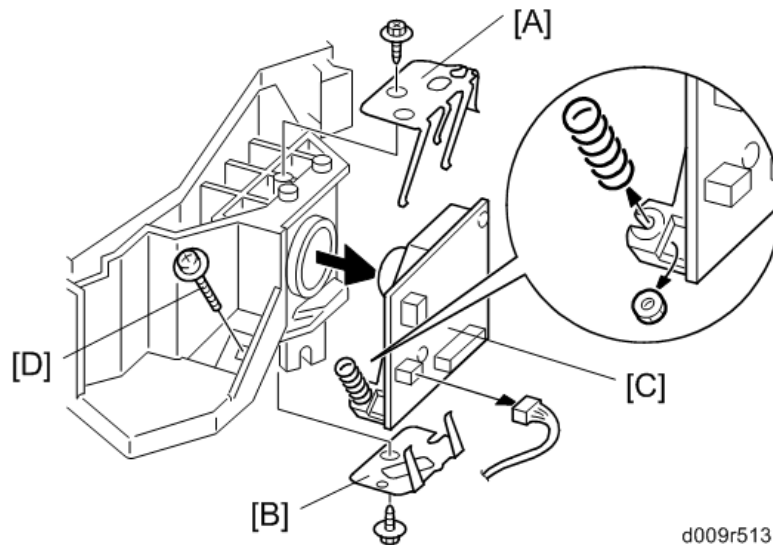

2. Upper spring plate [A] (☞ x 1)
3. Lower spring plate [B] (☞ x 1)
4. LD unit [C] (☞ x 1, ☞ x1, spring x 1)

**Note**

- To avoid damaging the LD board, hold it securely when disconnecting the connectors. Hold the laser unit casing.

5. After replacing the LD board, do the "Laser Beam Pitch Adjustment" (described in the following section). Keep the lower inner cover removed before doing this adjustment because you need to adjust the adjustor screw [D] on the LD unit with a screwdriver.

### **Laser Beam Pitch Adjustment**

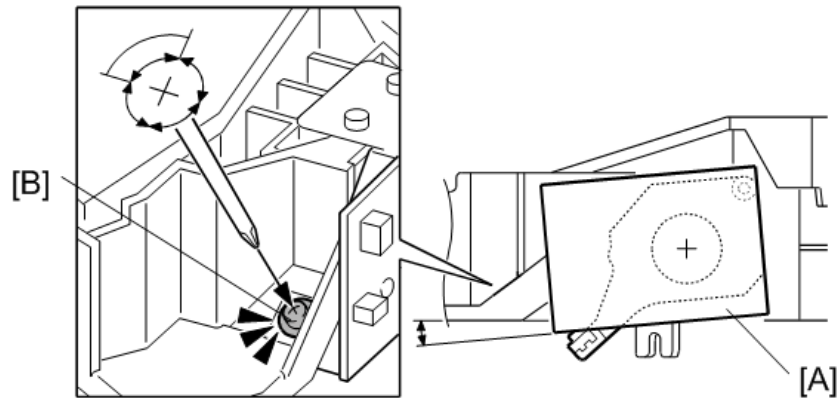

d009r513a

1. Install a (new) LD unit [A] with the left side of the LD unit being lower than the right side. (This makes this adjustment easier.)
2. Print the test pattern "Hounds Tooth Check (Horizontal)" (No. 16 in SP2109-001).
3. Check if the vertical stripes appear on the second pattern (counted from the leading edge) of the printout.
  - Correct: No vertical stripes appear (see the sample following this procedure.)
  - Wrong: Vertical stripes appear (see the sample following this procedure.)
4. Turn the adjustor screw [B] by 90 degrees clockwise (counterclockwise).

**Note**

- If the image of the printout is getting worse, try reverse rotation (clockwise  $\leftrightarrow$  counterclockwise)
5. Print the test pattern and check it out.
  6. Try steps 2 to 4 again until you get an image with no vertical stripes.
  7. Reassemble the machine after completing this adjustment.

**Correct: No vertical stripes appear**

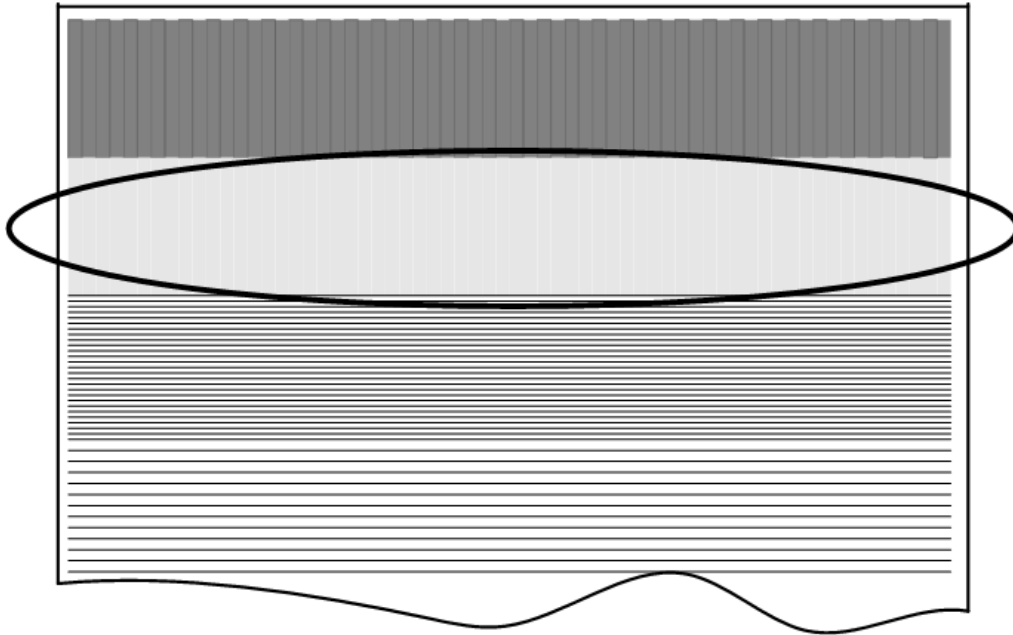

d009r552

**Incorrect: Vertical stripes appear**

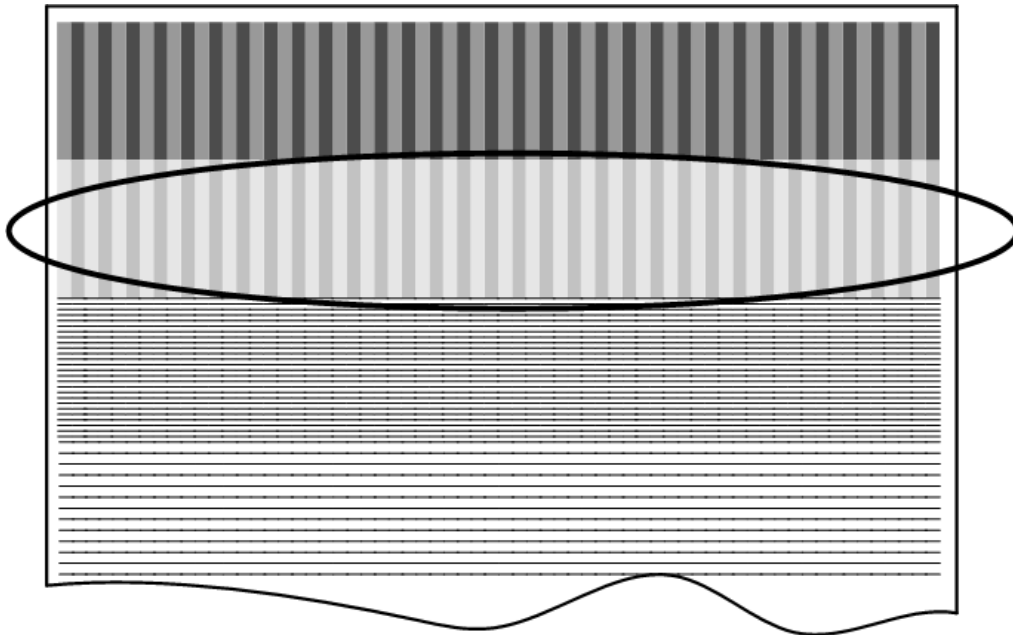

d009r553

Replacement  
and  
Adjustment



## 4.5 PCDU

### 4.5.1 PCDU (PHOTOCONDUCTOR AND DEVELOPMENT UNIT)

1. Open the front door.

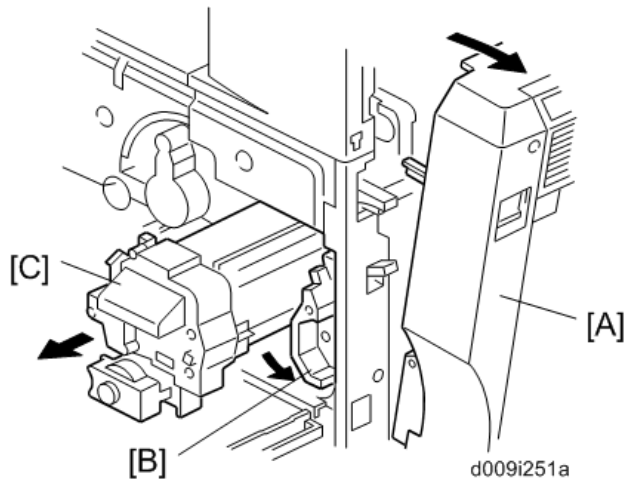

2. Open the right door [A].
3. Release the lock lever [B].
4. Pull out the PCDU [C] and place it on a clean flat surface.

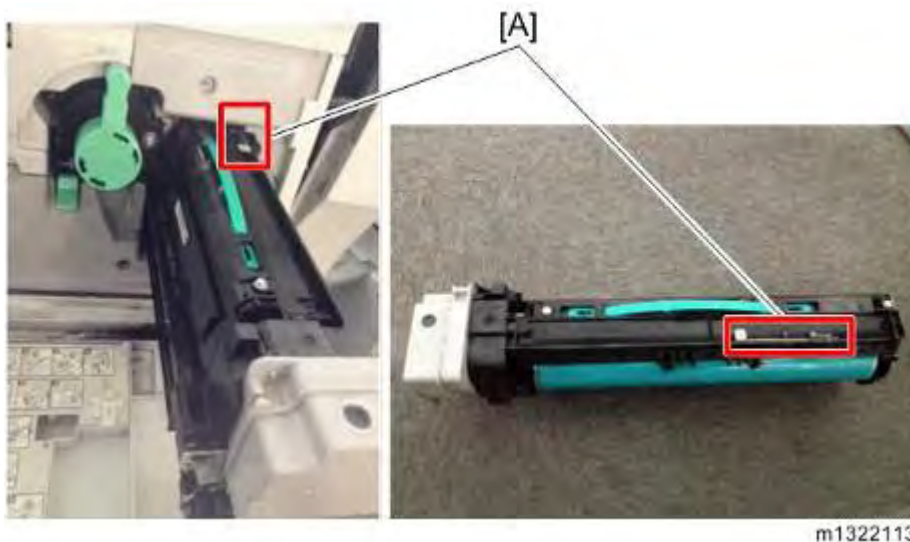

#### ↓ Note

- When you pull out the PCDU, push the security lock [A] of the PCDU. If the lock is not pressed, the PCDU will be stuck in the machine and cannot be pulled out completely. The lock prevents the PCDU from coming out accidentally.
  - You don't need to push the security lock when installing a PCDU.
5. Spread a large piece of paper on a flat surface.

**Note**

- Make sure the area is free of pins, paper clips, staples, etc. to avoid attraction to the magnetic development roller.

## Reinstallation

Open the right cover before you install the PCDU in the machine.

### 4.5.2 DRUM

- Remove the PCDU (☞ p.4-16)

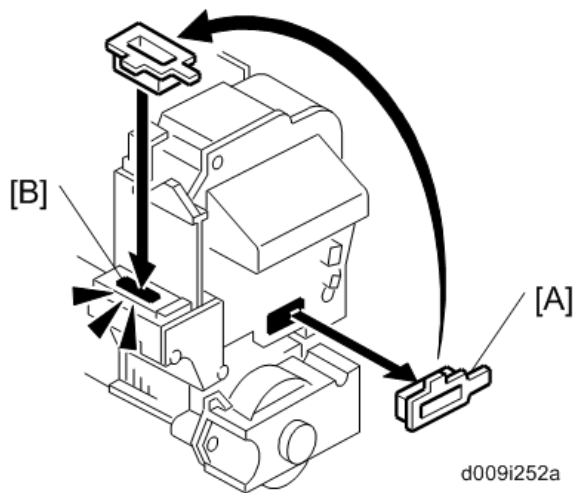

- Toner cap [A]
- Insert cap [A] into the opening of the PCDU [B].

**Note**

- Make sure that the cap is inserted completely into the opening.

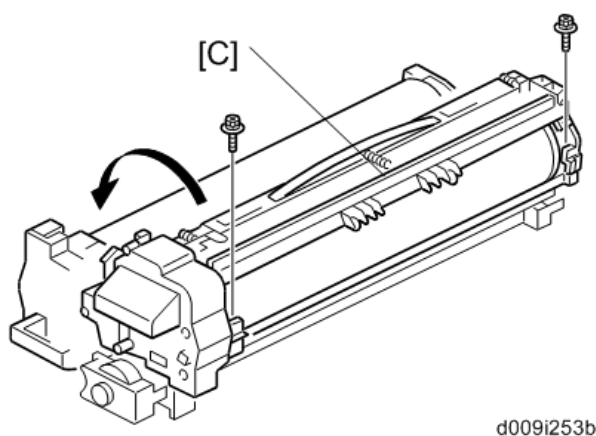

- Open the PCDU [C] (☞ x 2).

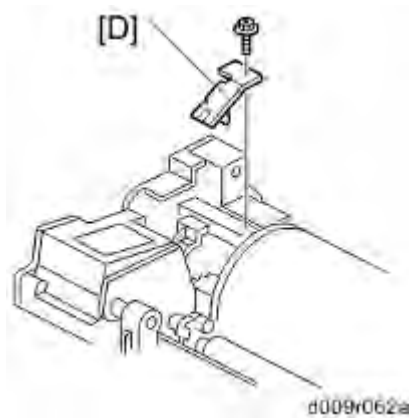

5. Bracket [D] (🔑 x 1)

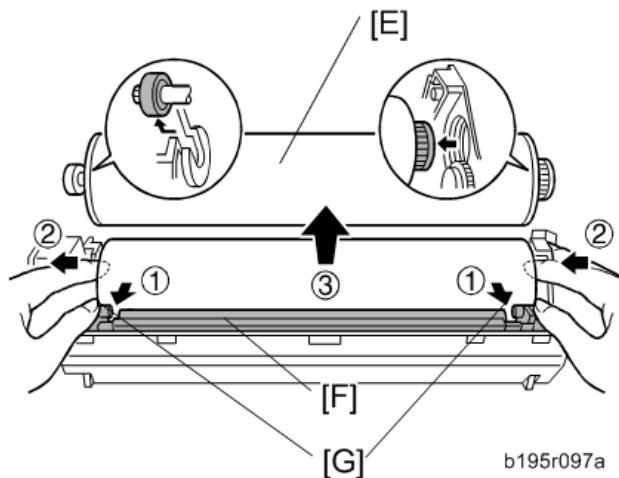

6. Pull the drum [E] towards the front ② (the left side in the illustration) while releasing the charge roller [F] using the release levers ① [G], and then remove the drum ③.

**⚠ CAUTION**

- Never touch the drum surface with bare hands.

***Re-installation***

1. Replace the drum and close the PCDU (🔑 x 2).
2. Put the opening cap [A in the previous procedure] back in its original place.
3. After replacing the drum, do these SPs:
  - SP 2001: Charge Bias Setting – make sure that this is at the default setting
  - SP 3001-2: P Sensor Initial Setting (P sensor = ID Sensor)
  - SP 2805: Process Setting
  - SP 2810-1: Grayscale Setting

### 4.5.3 PICK-OFF PAWLS

1. Drum (☛ p.4-17)

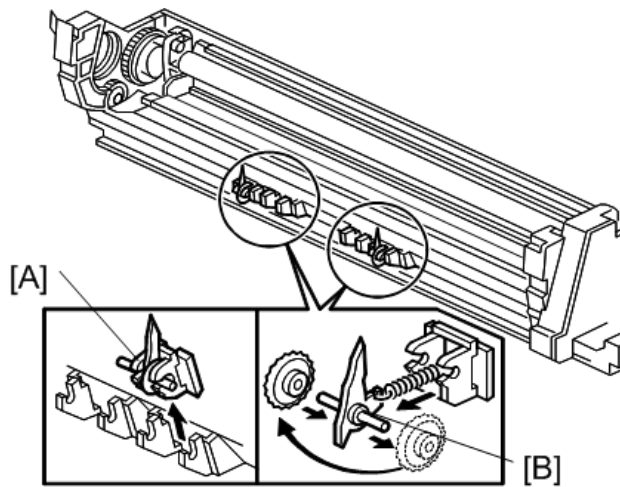

b195r933

2. Pawl assembly [A]
3. Pick-off pawl [B] (spring x 1, spur x 1)

#### ***Pick-off Pawl Position Adjustment***

If the pick-off pawl has marked the drum with a line, the pick-off pawl position can be adjusted using either method:

- Changing the spur position
- Changing the pick-off pawl assembly position

## 4.5.4 CHARGE ROLLER AND CLEANING ROLLER

1. Drum (☞ p.4-17)

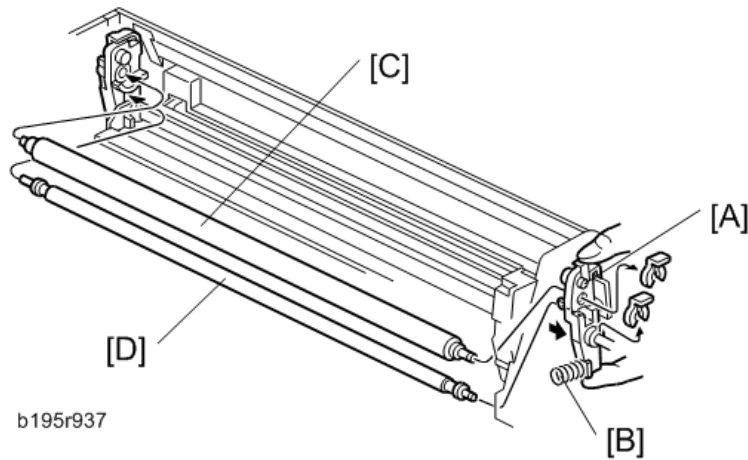

2. Push the charge roller holder [A] toward the front of the drum (☞ x 2) and remove the spring [B].
3. Charge roller [C].

**Note**

- Disengage the charge roller on the right side to remove it. Try to avoid touching the charge roller.

4. Cleaning roller [D]

**Note**

- Disengage the cleaning roller on the left to remove it.

5. After replacing the charge roller and cleaning roller, check the value of SP2001-001. If it is not at the standard value (1500), set SP2001-001 to "1500".

**Note**

- If this is not done, the carrier will be attracted to the drum because the charge roller voltage will be too high.

## 4.5.5 DRUM CLEANING BLADE

1. Drum (☛ p.4-17)
2. Charge roller and cleaning roller (☛ p.4-20)

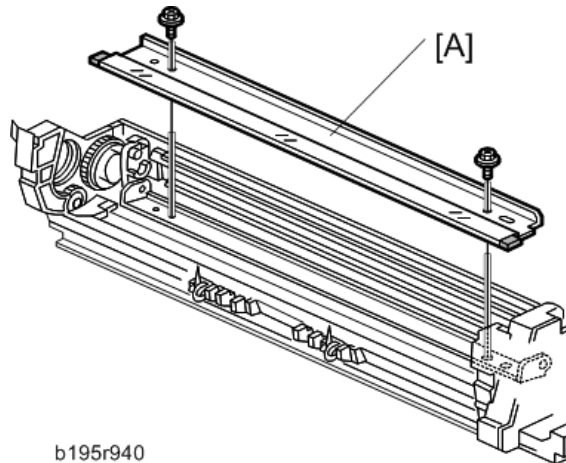

3. Remove drum cleaning blade [A] (☛ x 2)

### **Re-installation**

Put toner on the edge of cleaning blade and the mylar at the back side of cleaning blade before re-installing this blade.

## 4.5.6 ID SENSOR

1. PCDU (☛ p.4-16)
2. Fusing unit (☛ p.4-38)

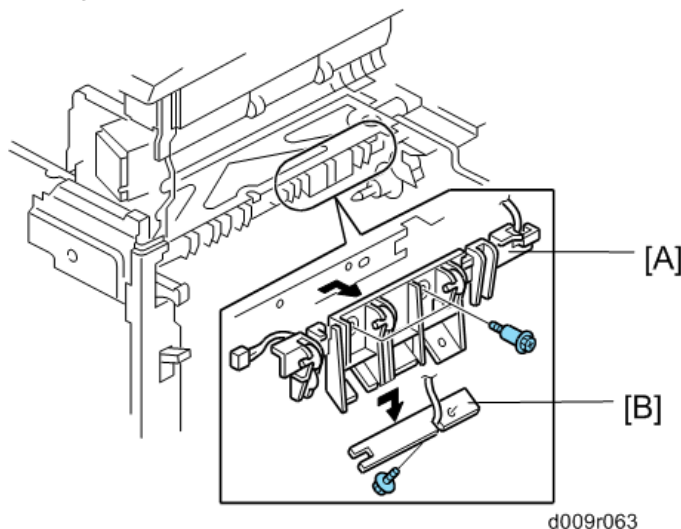

3. ID sensor bracket [A] (☛ x 2, ☛ x 1)
4. ID sensor [B] (☛ x 1)

#### **Note**

- Do SP3-001-002 to initialize the ID sensor after replacing.

## 4.6 DEVELOPMENT

### 4.6.1 DEVELOPMENT FILTER

1. PCDU (☛ p.4-16)
2. Open the PCDU. (☛ p.4-17 "Drum")

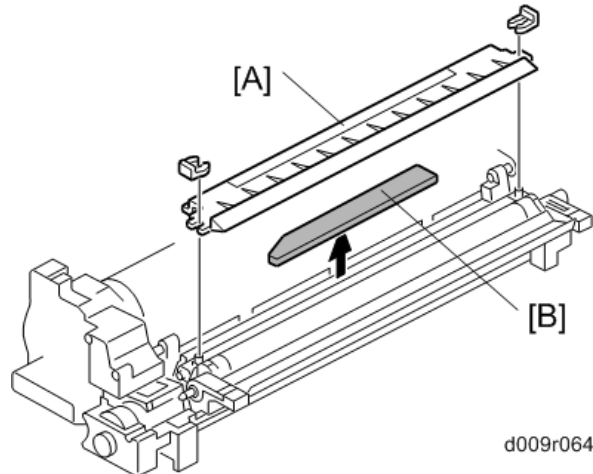

3. Upper development cover [A] (☛ x2)
4. Development filter [B]

### 4.6.2 DEVELOPMENT ROLLER

1. PCDU (☛ p.4-16)
2. Open the PCDU. (☛ p.4-17 "Drum")
3. Upper development cover (☛ p.4-22 "Development Filter")

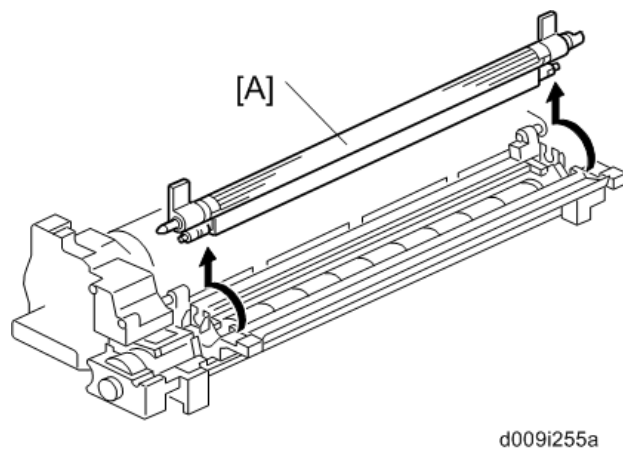

4. Development roller [A]

**Note**

- Work carefully to avoid scratching or nicking the development roller.

## Cleaning Procedure

1. PCDU (☛ p.4-16)

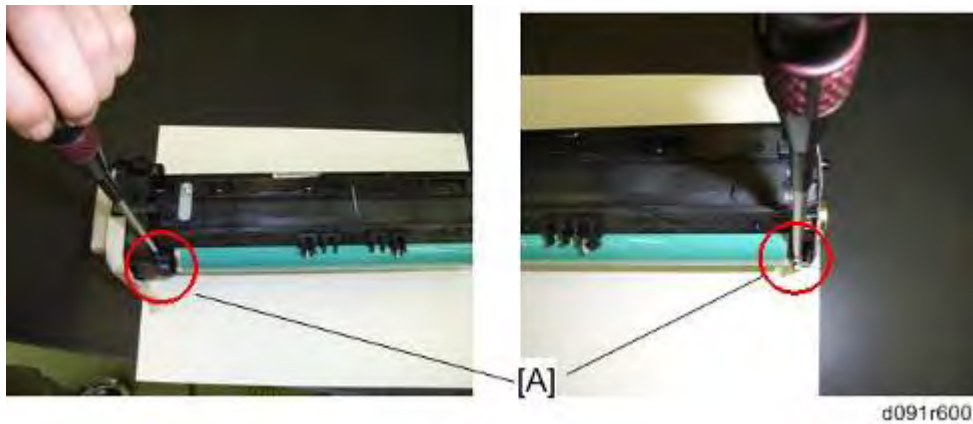

2. Remove the two screws [A] and open the PCDU as shown above.



3. Remove the upper development cover [A] (☛ x 2).

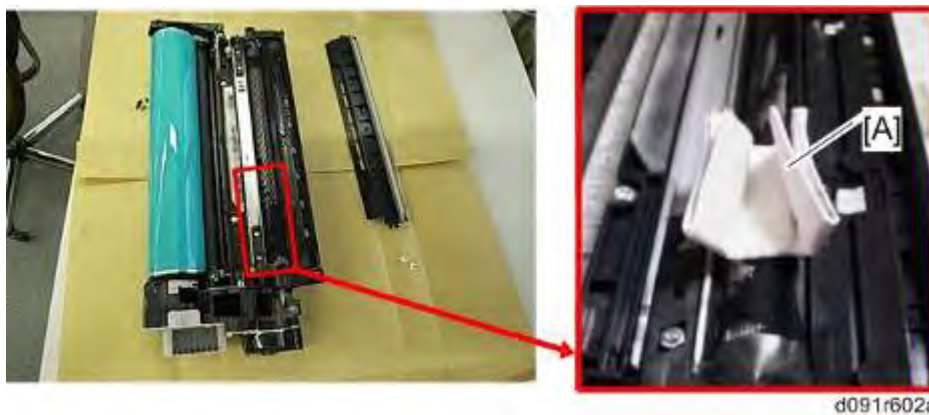

4. Fold up a sheet of copy paper [A] to fit the width of the uncovered area of the development roller, as shown below.
5. Slide the paper [A] along the length of the roller to clean the toner off the surface.





6. Rotate the development roller [A] in the direction of the arrow until the section you cleaned is no longer visible.
7. Repeat steps 5 and 6 until you have cleaned the entire surface of the roller.
8. Reassemble the PCDU and install the PCDU into the machine.

### 4.6.3 DEVELOPER

1. PCDU (☛ p.4-16)
2. Open the PCDU. (☛ p.4-17 "Drum")
3. Development roller (☛ p.4-22)

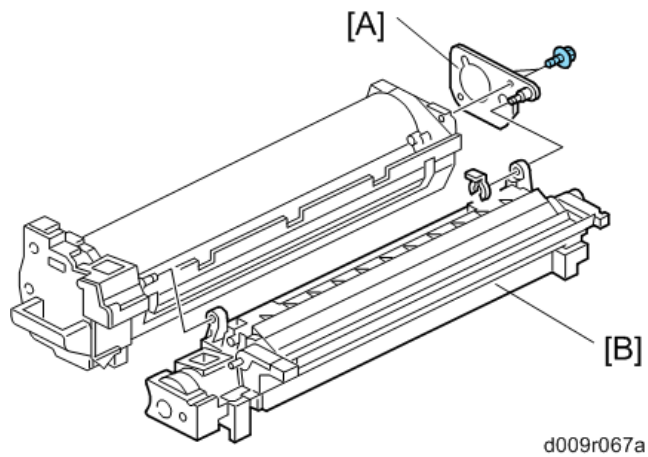

4. Joint bracket [A] (☛ x 2, ☛ x 1)
5. Development unit [B]

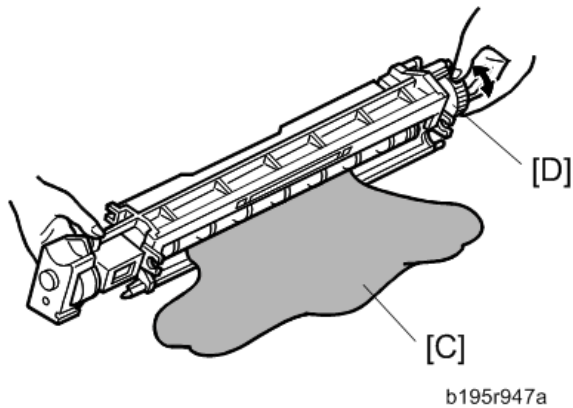

6. Tip out the old developer [C].
7. Turn drive gear [D] to ensure that no developer remains in the unit or on the developer roller.

**Note**

- Dispose of the used developer in accordance with local regulations. Work carefully to avoid scratching or nicking the development roller.
8. Clean the development roller with a dry cloth.

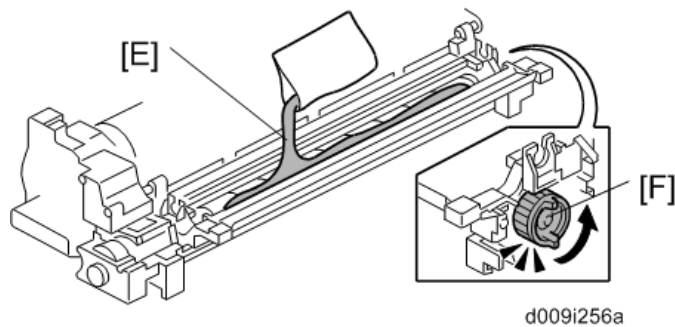

9. Pour approximately 1/3 of the developer [E] evenly along the length of the development unit.
10. Rotate the drive gear [F] to work the developer into the unit.
11. Repeat steps 8 and 9 until all toner is in the unit and level with the edges.
12. Re-install the development roller.

**Note**

- Make sure that the seals at the both sides of the development roller are set inside the case after you re-install the development roller.

## Development

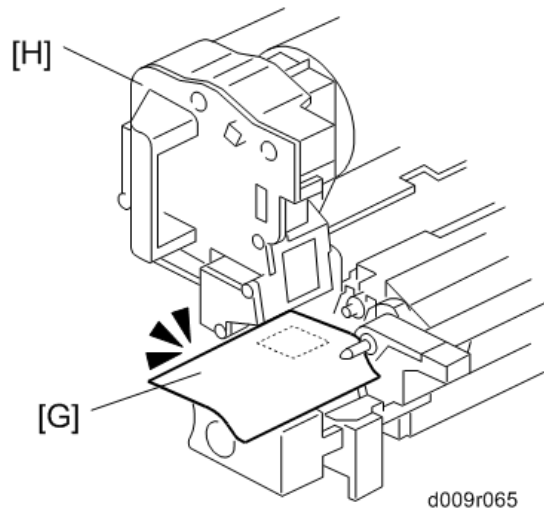

13. Place a piece of paper [G] over the toner entrance hole. This prevents used toner falling from the drum into the development unit during the TD sensor initial setting and interfering with the Vref setting (toner density reference voltage)
14. Secure the drum [H] to the development unit, to close the PCDU (🔑 x 2).
15. Install the PCDU in the machine and close the front and right doors.
16. Turn on the main power switch, and wait for the machine to warm up.
17. Do SP2801 to initialize the TD sensor and enter the developer lot number.
18. After performing the TD sensor initial setting, remove the sheet of paper from the PCDU.

## 4.6.4 TD SENSOR

1. PCDU (☛ p.4-16)
2. Empty all developer from the development unit. (☛ p.4-24 "Developer")

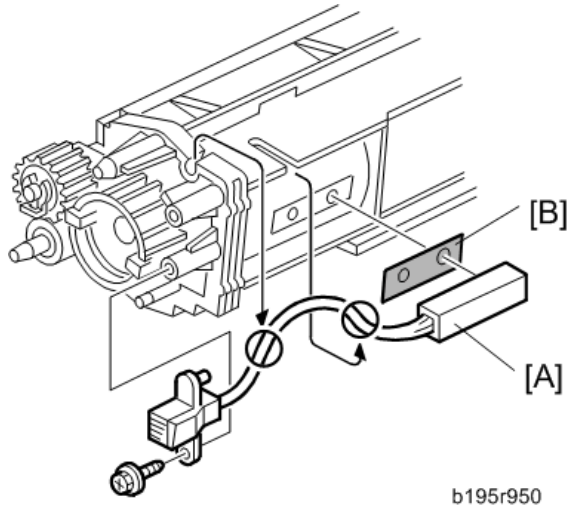

3. Seal
4. TD sensor [A] (☛ x1)
  - ⓘ **Note**
    - The TD sensor is attached to the casing with double-sided tape [B]. Pry it off with the flat head of a screwdriver. Use fresh double-sided tape to re-attach the sensor.
5. Pour new developer into the development unit and perform the TD sensor initial setting using SP2-801.

ⓘ **Note**

- When performing the TD sensor initial setting, cover the toner entrance hole with a piece of paper.

## 4.7 TRANSFER

### 4.7.1 TRANSFER BELT UNIT

**Note**

- To avoid exposing the drum to strong light, cover it with paper if the right cover will be open for a long period.

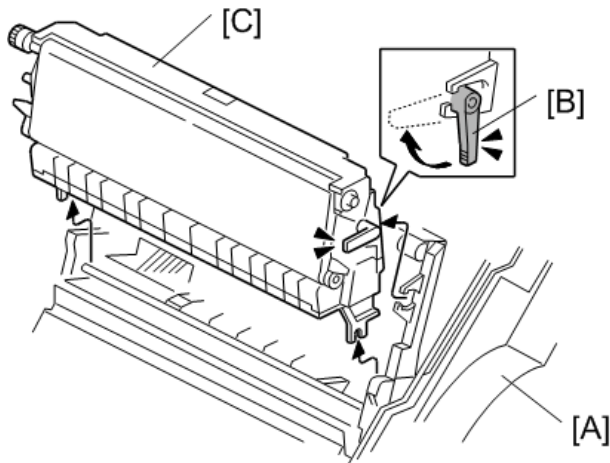

d009r025

1. Open the right door [A].
2. Release the lever [B].
3. Transfer belt unit [C]

**Note**

- Avoid touching the transfer belt surface.

## 4.7.2 TRANSFER BELT

1. Transfer belt unit (☛ p.4-28)

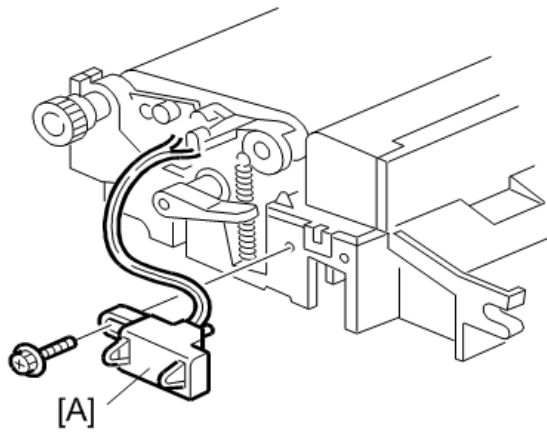

d009r027

2. Connector [A] (☛ x 1)

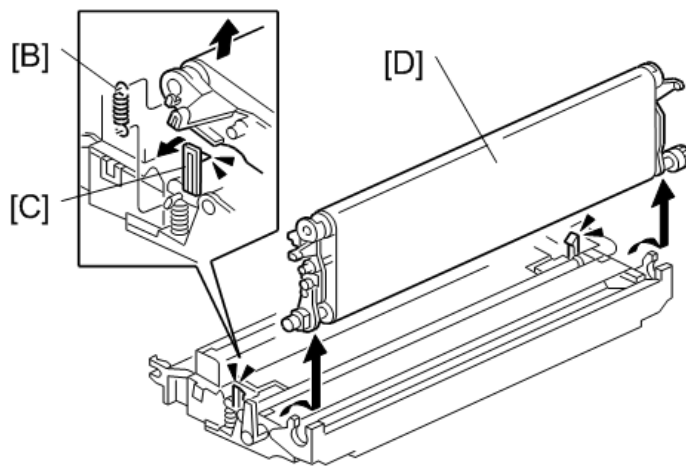

d009r028

3. Remove the springs (front and rear) [B].
4. Release the hooks (front and rear) [C].
5. Transfer belt with rollers [D]

## Transfer

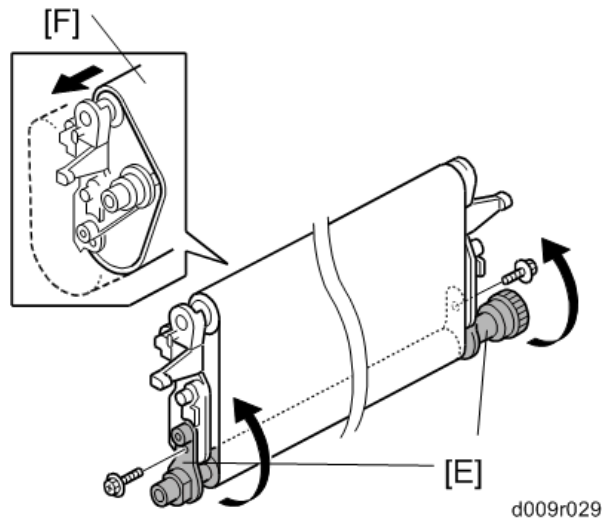

6. Lay the transfer belt with rollers on a flat clean surface, and fold the unit [E] to release the tension on the belt (⚙ x 2).



7. Transfer belt [F]

### ⚠ Note

- Avoid touching the transfer belt surface.
- Before installing the new transfer belt, clean all the rollers and shafts with alcohol to prevent the belt from slipping.
- When reinstalling the transfer belt, make sure that the belt is under the pin [F].
- To avoid damaging the transfer belt during installation, manually turn the rollers and make sure that the new transfer belt is not running over the edges of any of the rollers.

### 4.7.3 TONER OVERFLOW SENSOR

1. Transfer belt unit (🔧 p.4-29)

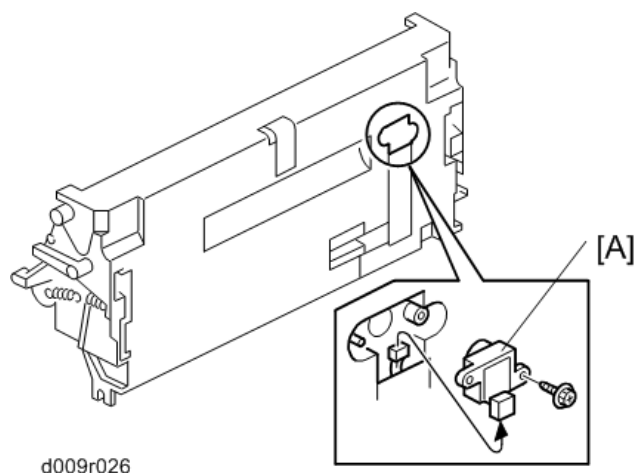

2. Toner overflow sensor [A] (🔧 x 1, 📦 x 1)

### 4.7.4 TRANSFER BELT CLEANING BLADE

1. Transfer belt unit (🔧 p.4-28)
2. Transfer belt (🔧 p.4-29)

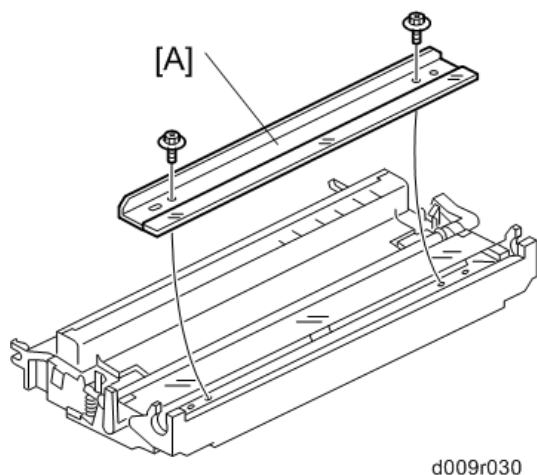

3. Transfer belt cleaning blade [A] (🔧 x 2)

**Note**

- Avoid touching the edge of the new blade. Check the new blade for dust or damage.



## 4.8 PAPER FEED

### 4.8.1 PAPER FEED UNIT

#### *Tray 1 and Tray 2*

1. Right rear cover (🔧 p.4-5)
2. Duplex unit (🔧 p.4-54)
3. Pull out tray 1 and tray 2.



4. Paper guide plate [A] (hook x 2)



5. Harness cover [A] (🔧 x 1)

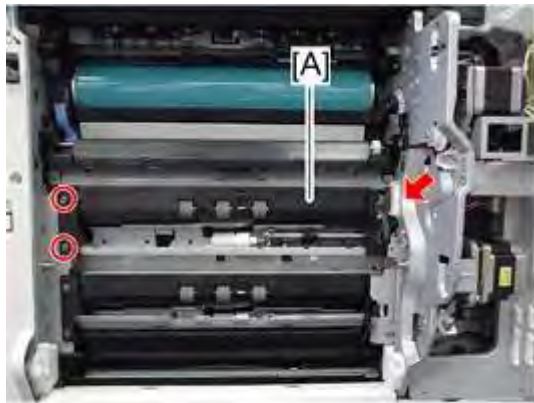

d129r807

6. Paper feed unit [A] (🔧 x 2, 📄 x 1)

## 4.8.2 PICK-UP, FEED AND SEPARATION ROLLERS

### Tray 1 and Tray 2

1. Paper feed unit (📄 p.4-32)

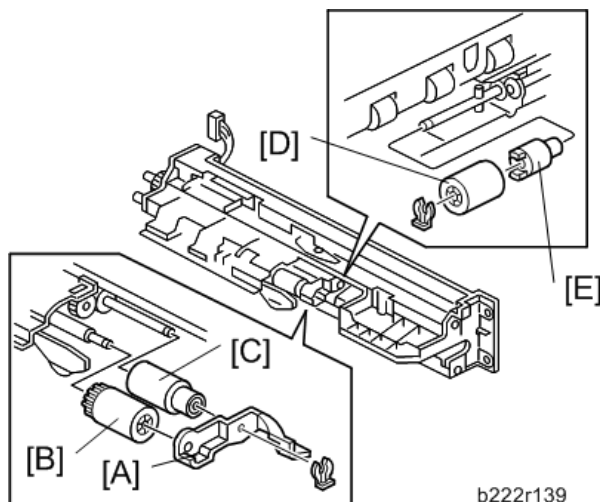

b222r139

2. Roller holder [A] (🔧 x 1)
3. Pick-up roller [B]
4. Feed roller [C]
5. Separation roller [D] and torque limiter [E] (🔧 x 1)

Replacement  
and  
Adjustment

### 4.8.3 TRAY LIFT MOTOR

1. Rear cover (🔧 p.4-4)

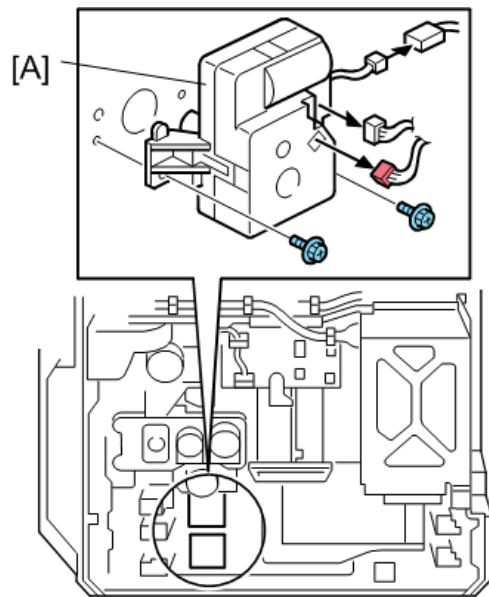

d009r013

2. Tray lift motor 1 or 2 [A] (🔧 x 2, 📦 x 3)

## 4.8.4 RELAY, TRAY LIFT, PAPER END AND PAPER FEED SENSORS

### Tray 1 and Tray 2

1. Right rear cover (☛ p.4-5)
2. Duplex unit (☛ p.4-54)
3. Paper feed unit (☛ p.4-32)

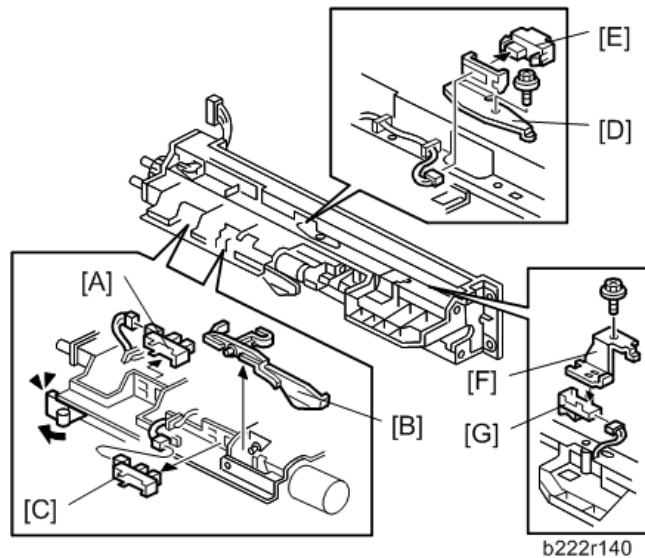

4. Tray lift sensor [A] (☛ x 1)
5. Paper end feeler [B] and paper end sensor [C] (hook, ☛ x 1 each)
6. Relay sensor bracket [D] (☛ x 1)
7. Relay sensor [E] (☛ x 1, hook)
8. Paper feed sensor bracket [F] (☛ x 1)
9. Paper feed sensor [G] (☛ x 1, hook)

## 4.8.5 REGISTRATION SENSOR

1. Right rear cover (☛ p.4-5)
2. Duplex unit (☛ p.4-54)
3. Paper feed unit for tray 1 (☛ p.4-32 "Paper Feed Unit")
4. Paper Trays 1 and 2

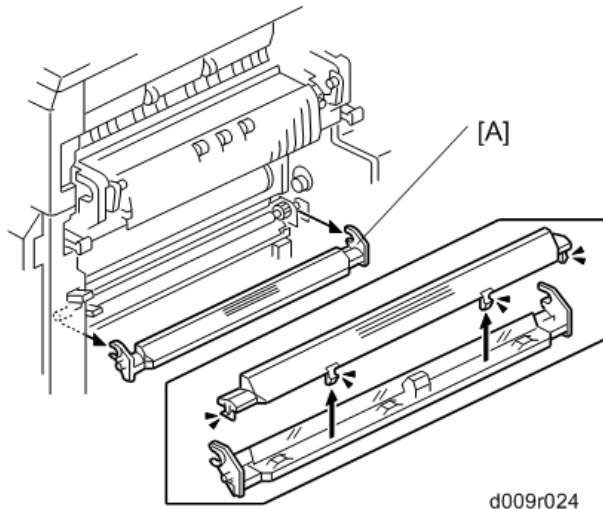

5. Paper dust box [A]

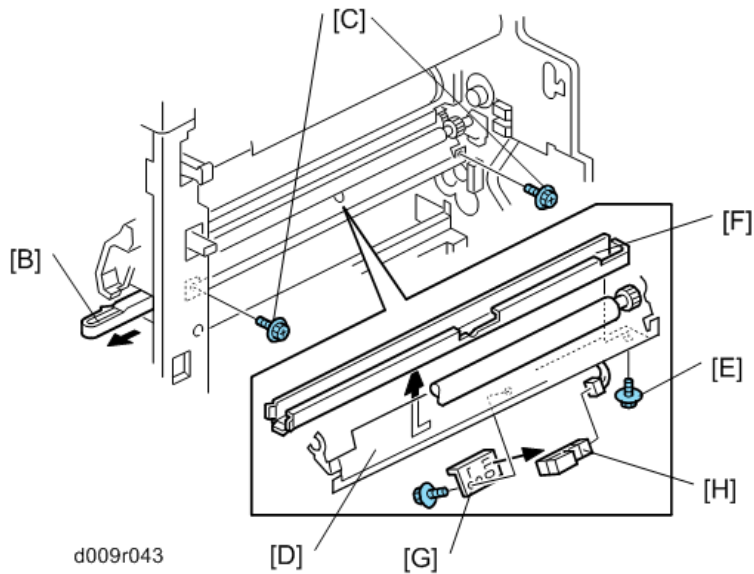

6. Open the front door.
7. Pull out the paper dust container [B].
8. Remove two screws [C].

**Note**

- This makes the paper guide [D] tilt a little bit. Now you can access the screw [E].

9. Dust container rail [F] (🔩 [E] x 1)

10. Sensor bracket [G] (🔩 x 1)

**Note**

- You can only access the screw on the sensor bracket from the inside (paper tray location) of the machine.

11. Registration sensor [H] (🔩 x 1, hooks)

***Reinstall the registration sensor***

It is very difficult to secure the sensor bracket to the frame. First attach the sensor bracket with tape temporarily.

## 4.9 FUSING

### 4.9.1 FUSING UNIT

#### **⚠ CAUTION**

- Turn off the main switch and wait until the fusing unit cools down before beginning any of the procedures in this section. The fusing unit can cause serious burns.

1. Turn off the main power switch.
2. Open the right door.

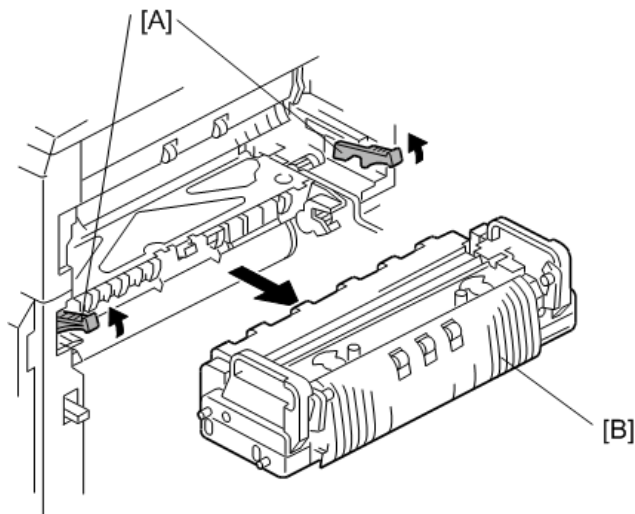

d009r045

3. Pull up the lock levers [A].
4. Pull the fusing unit [B] until you hear a click.

#### **↓ Note**

- The lock levers lock the fusing unit again at this time to prevent the fusing unit from falling down.
5. Pull up the lock levers [A] again, and then remove the fusing unit [B].

## 4.9.2 WEB ROLLER UNIT

1. Fusing unit (☛ p.4-38)

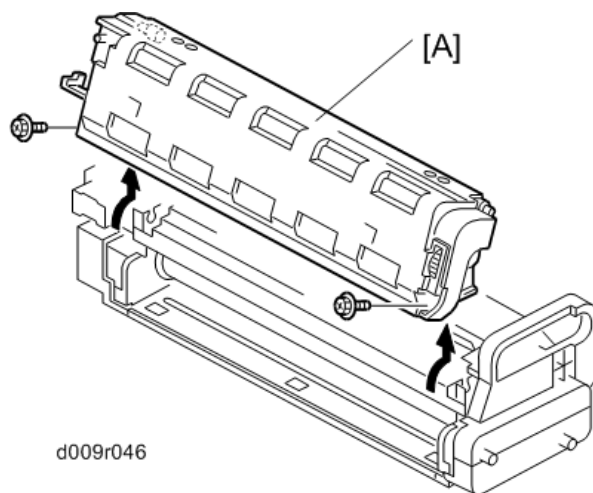

2. Web roller unit [A] (☛ x 2)



### 4.9.3 BRAKE PAD

1. Web roller unit (☛ p.4-39)

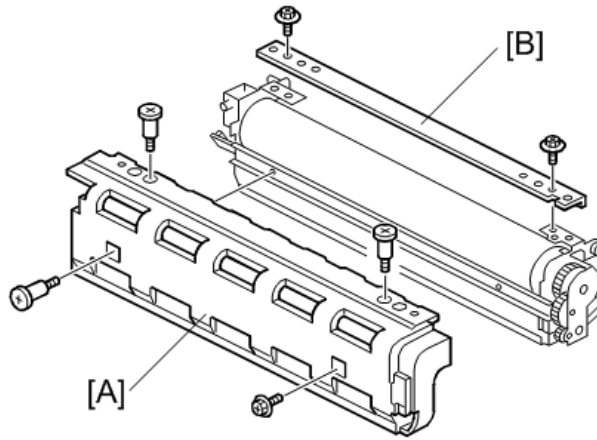

d129r103

2. Web left cover [A] (☛ x 1, stepped screw x 3)
3. Web top frame [B] (☛ x 2)

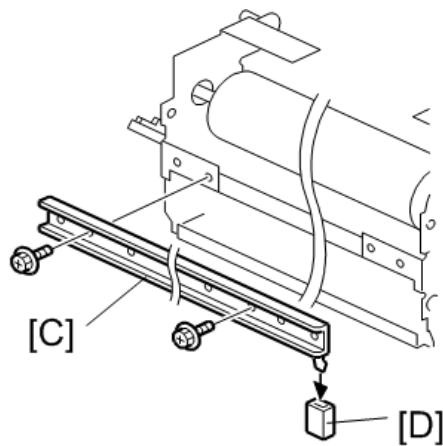

d009r048a

4. Web left frame [C] (☛ x 2)
5. Brake pad [D]

## 4.9.4 WEB HOLDER ROLLER AND WEB ROLLERS

1. Web roller unit (🔧 p.4-39)
2. Web left cover (🔧 p.4-40 "Brake Pad")
3. Web top frame (🔧 p.4-40 "Brake Pad")
4. Web left frame (🔧 p.4-40 "Brake Pad")

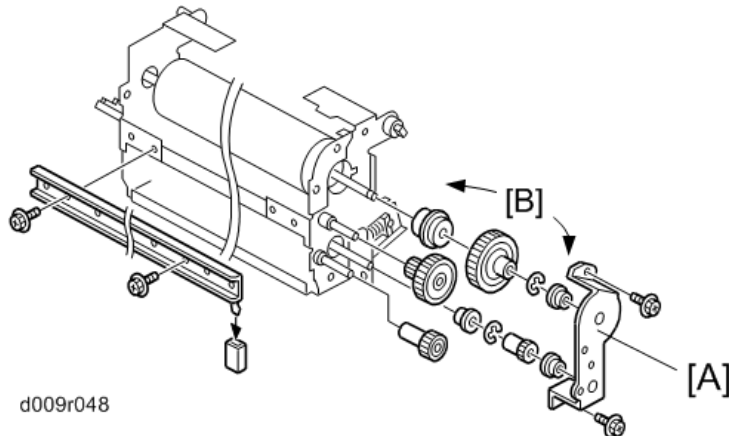

5. Front gear bracket [A] (🔧 x 2)
6. All gears and bushings (rear side) [B] (Ⓒ x 2)

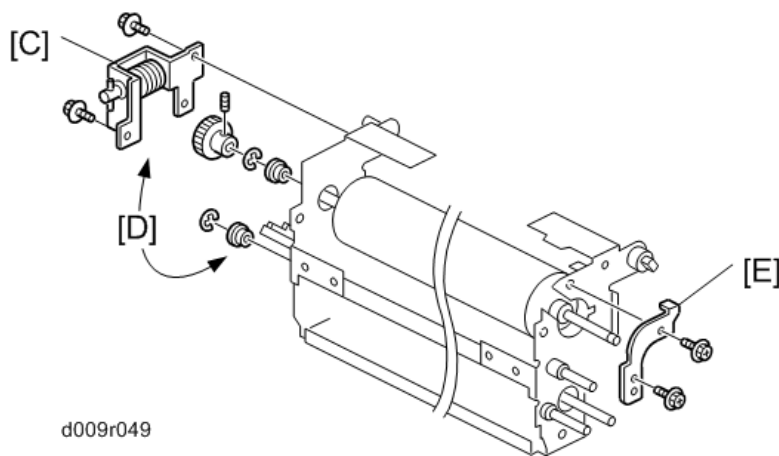

7. Rear gear bracket [C] (🔧 x 2)
8. All gear and bushings (rear side) [D] (Ⓒ x 2, spring x 1)
9. Front bracket [E] (🔧 x 2)

## Fusing

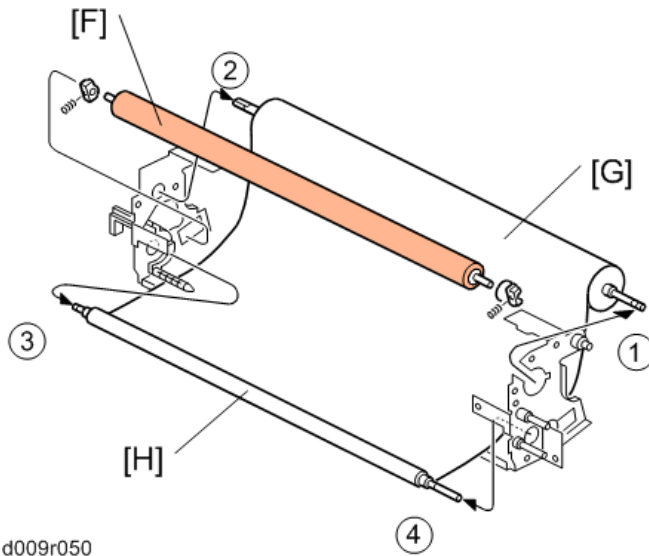

d009r050

10. Web holder roller [F] (holder x 2, spring x 2)
11. Web take up roller [G] (① → ②)
12. Web supply roller [H] (③ → ④)

### ***Installing a new web holder roller***

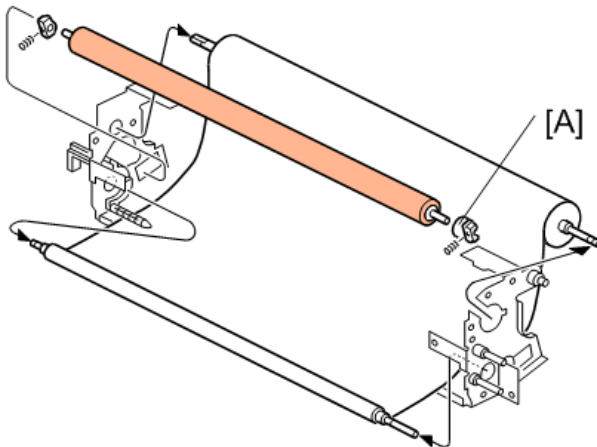

d009r050a

The holder [A] has a one-way clutch. Make sure that the holder [A] is set at the front side.

## Installing new web rollers

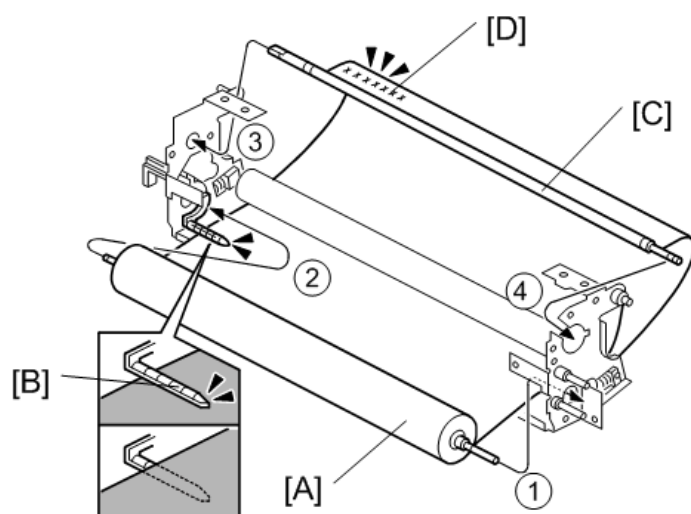

d009r051

1. Install the web supply roller [A] first (① → ②). Make sure that the web sheet is under the pin [B].
2. Install the web take up roller [C] (③ → ④). Make sure that the printed number [D] is outside the web take up roller.
3. Reinstall the rear gear bracket (☛ p.4-41 "Web Holder Roller and Web Rollers").
4. Reinstall the front and rear gears and bushings (☛ p.4-41 "Web Holder Roller and Web Rollers").
5. Reinstall the rear gear bracket (☛ p.4-41 "Web Holder Roller and Web Rollers").

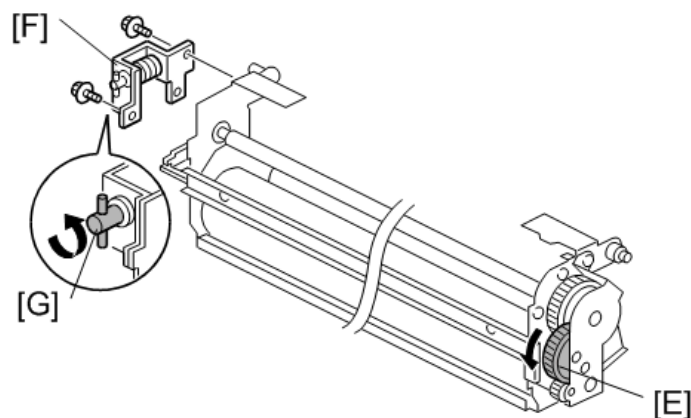

d009r051a

6. Turn the rear gear [E] in the arrow direction to remove the slack in the web sheet.
7. Reinstall the front gear bracket [F] (☛ p.4-41 "Web Holder Roller and Web Rollers").
8. Turn the coupling [G] in the arrow direction to remove the slack in the web sheet.
9. Reinstall the web unit.
10. If you install a new cleaning web, reset SP 7806-008 (press "Execute" on the LCD).

## 4.9.5 PRESSURE ROLLER CLEANING ROLLER

1. Fusing unit (☛ p.4-38)

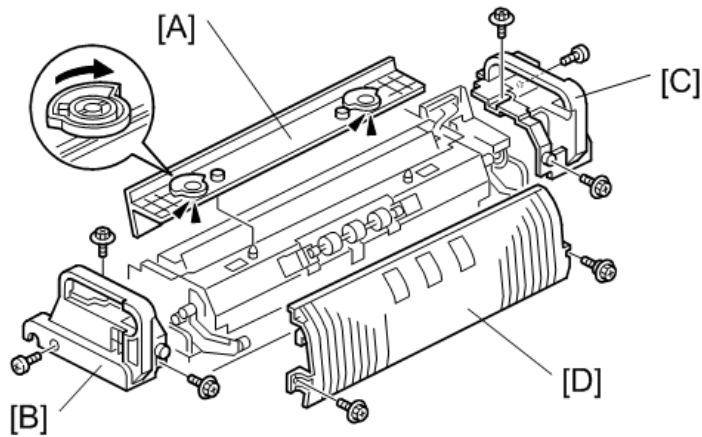

d009r052

2. Fusing exit guide [A] (lock x 2)
3. Fusing front upper cover [B] (☛ x 3)
4. Fusing rear upper cover [C] (☛ x 3)
5. Fusing outer guide [D] (front: ☛ x 1, rear: stepped screw x 1)

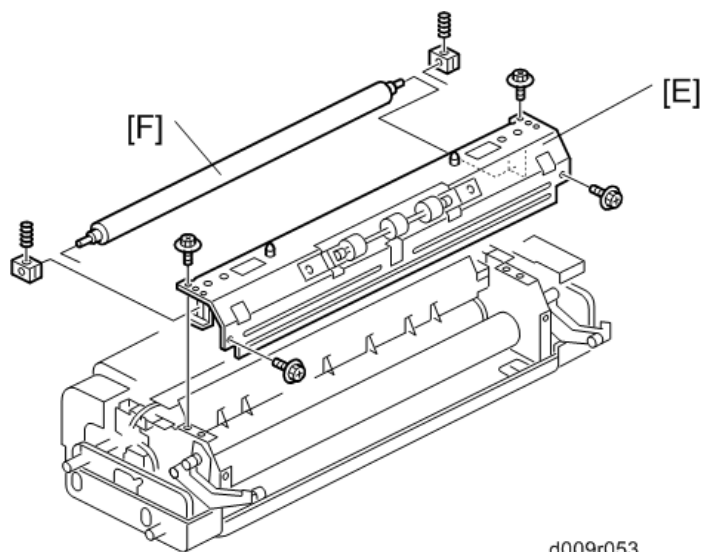

d009r053

6. Cleaning roller unit [E] (☛ x 4)
7. Pressure roller cleaning roller [F] (spring x 2, holder x 2)

## 4.9.6 THERMOSTATS

1. Fusing unit (☛ p.4-38)
2. Web roller unit (☛ p.4-39)

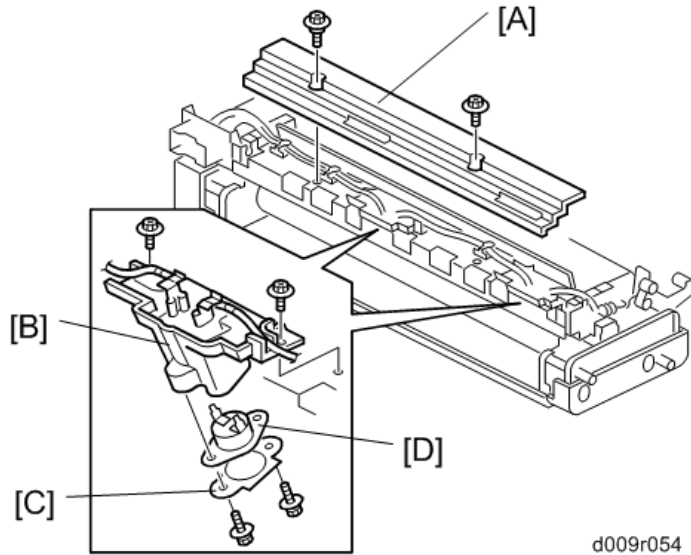

3. Fusing top cover [A] (front: ☛ x 1, rear: stepped screw x 1)
4. Thermostat holder [B] (☛ x 2)
5. Thermostat cover [C] (☛ x 2)
6. Thermostat [D] (terminal x 2)

## 4.9.7 THERMISTOR

1. Fusing unit (☛ p.4-38)
2. Web roller unit (☛ p.4-39)
3. Fusing top cover (☛ p.4-45 "Thermostats")

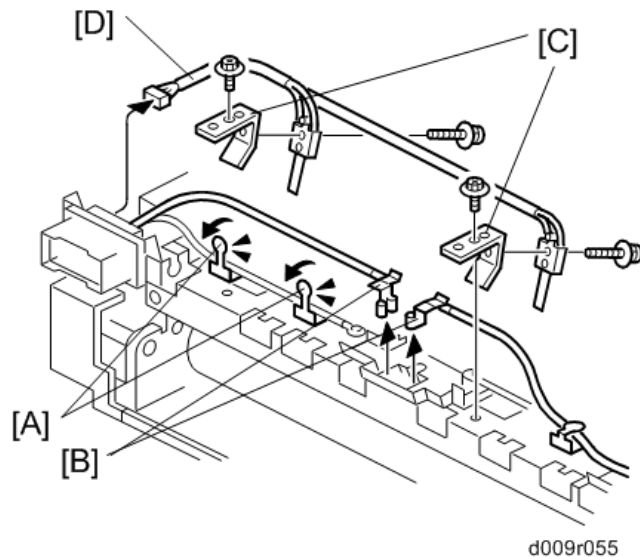

4. Pull the two tabs [A].
5. Disconnect the two terminals [B].
6. Sensor stays [C] (☛ x 1 each)
7. Thermistors [D] (☛ x 2, ☛ x 1)

## 4.9.8 HOT ROLLER STRIPPERS

1. Fusing unit (☛ p.4-38)
2. Web roller unit (☛ p.4-39)
3. Fusing top cover (☛ p.4-45 "Thermostats")

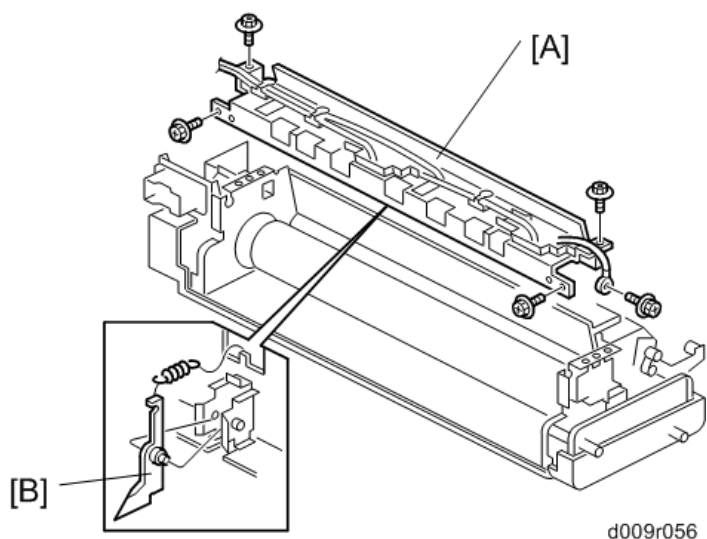

4. Fusing top frame [A] (☛ x 5)

**Note**

- The cords on this frame are still connected to the fusing unit at this time. Be careful not to damage the cords when removing the hot roller stripper [B].

5. Hot roller stripper [B] (spring x 1)



## 4.9.9 FUSING LAMPS

1. Fusing unit (☛ p.4-38)
2. Web roller unit (☛ p.4-39)
3. Fusing top cover (☛ p.4-45 "Thermostats")

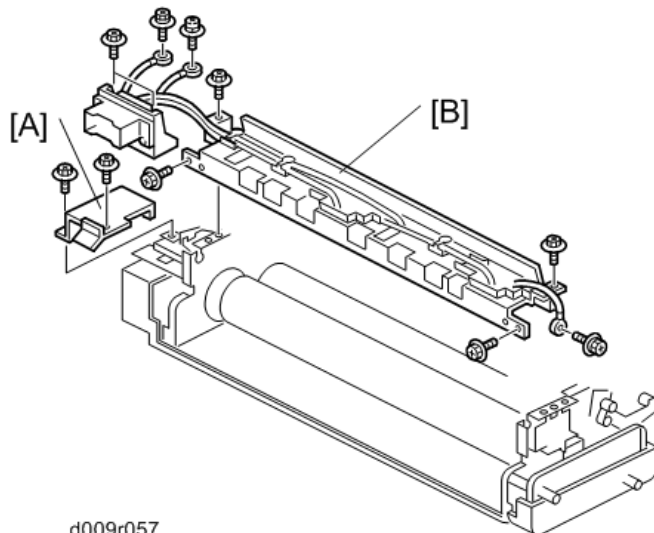

4. Connector cover [A] (☛ x 2)
5. Fusing top frame with connector [B] (☛ x 9)

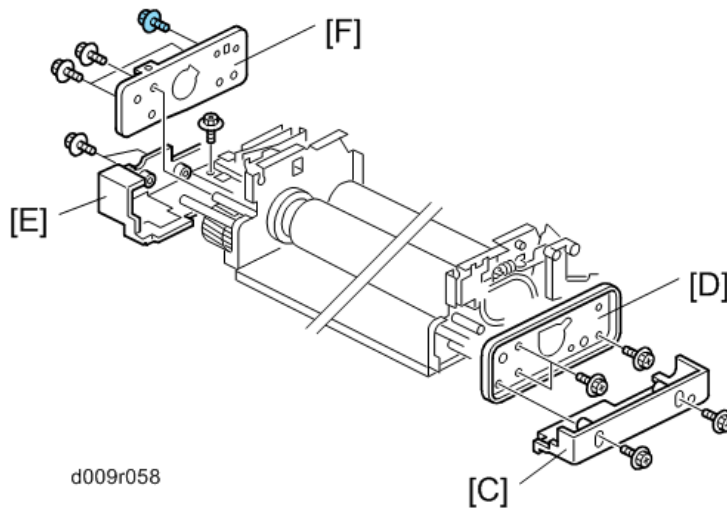

6. Fusing front lower cover [C] (☛ x 2)
7. Fusing front frame [D] (☛ x 3)
8. Fusing rear lower cover [E] (☛ x 2)
9. Fusing rear frame [F] (☛ x 5)

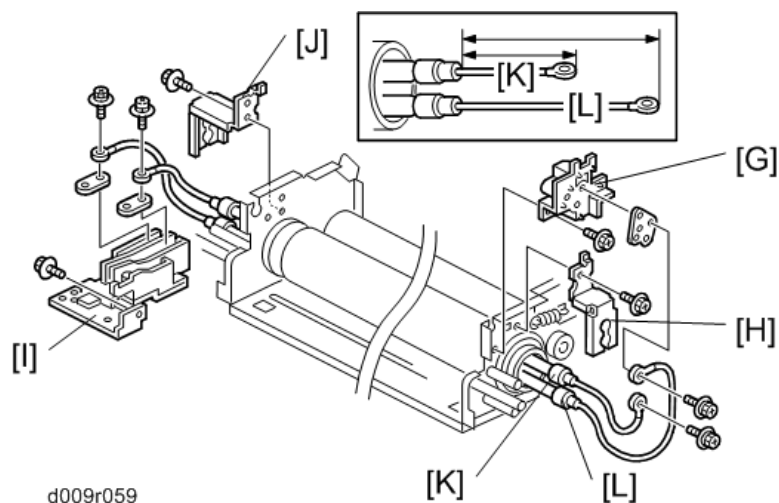

d009r059

10. Terminal bracket [G] (🔩 x 4)
11. Front holder bracket [H] (🔩 x 1)
12. Terminal base [I] (🔩 x 3)
13. Rear holder bracket [J] (🔩 x 1)
14. Fusing lamp-Center (550W) [K]
15. Fusing lamp-End (750W) [L]

### 4.9.10 HOT ROLLER AND PRESSURE ROLLER

1. Fusing lamps-Center and End (☛ p.4-48 "Fusing Lamps")

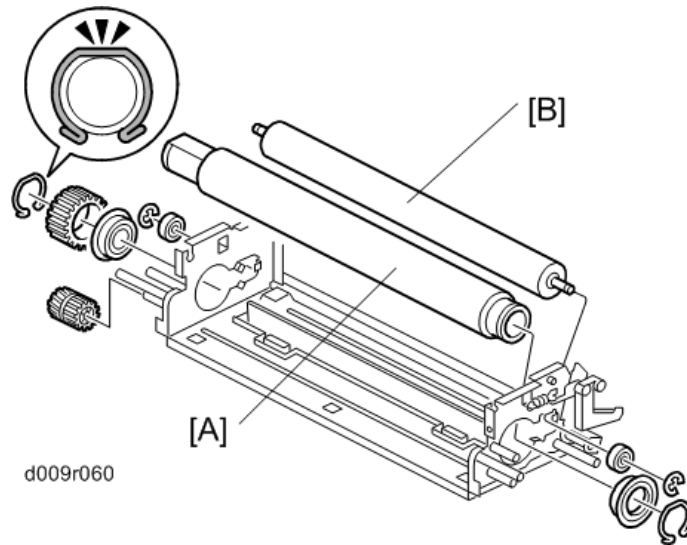

2. Hot roller [A] (snap ring x 2, gear x 2, bushing x 2)
3. Pressure roller [B] (☛ x 2, bushing x 2)

## 4.10 PAPER EXIT

### 4.10.1 PAPER EXIT UNIT

1. Fusing unit (☛ p.4-38)
2. Fusing exhaust fan duct (☛ p.4-84 "Fusing Exhaust Fan")

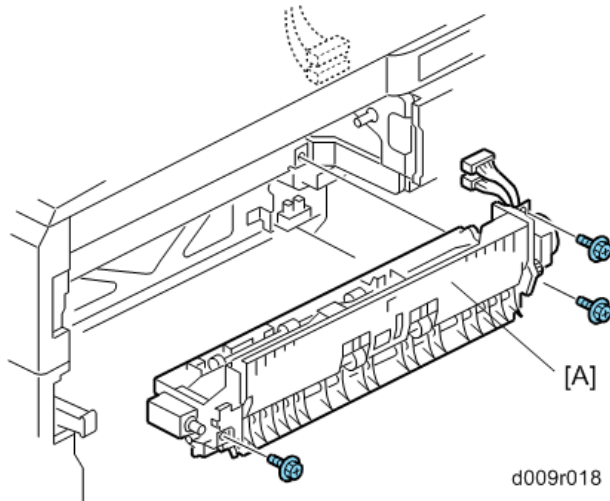

3. Paper exit unit [A] (☛ x 3, ☛ x 2)

## 4.10.2 FUSING EXIT, PAPER OVERFLOW, AND PAPER EXIT SENSORS

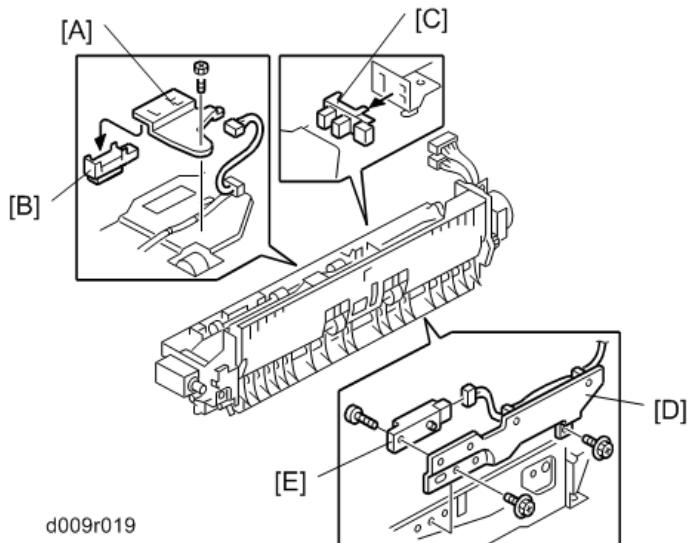

- d009r019
1. Paper exit unit ( p.4-51)
  2. Sensor bracket [A] ( x 1)
  3. Paper exit sensor [B] ( x 1, hooks)
  4. Paper overflow sensor [C] ( x 1, hooks)
  5. Sensor bracket [D] ( x 2)
  6. Fusing exit sensor [E] ( x 1, x 1)

### 4.10.3 JUNCTION JAM SENSOR

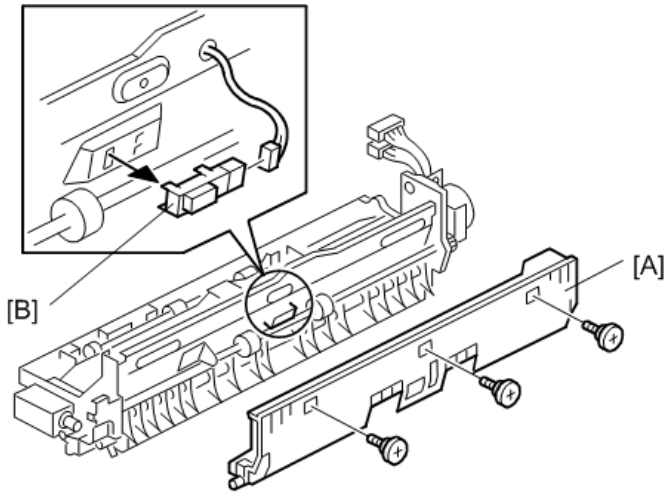

d009r020

1. Paper exit unit (☛ p.4-51)
2. Paper guide [A] (🔩 x 3)
3. Junction jam sensor [B] (🔩 x 1)

### 4.10.4 PAPER EXIT MOTOR

1. Paper exit unit (☛ p.4-51)

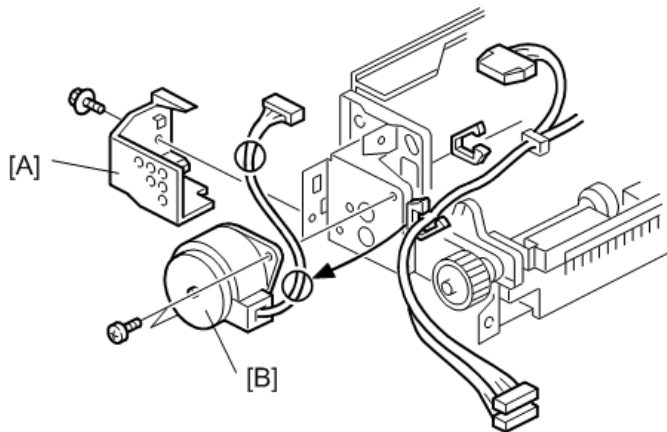

d009r021

2. Motor cover [A] (🔩 x 1)
3. Exit motor [B] (🔩 x 2, 🛠️ x 2, 🛠️ x 1)

Replacement  
and  
Adjustment

## 4.11 DUPLEX

### 4.11.1 DUPLEX UNIT

1. Right rear cover (☛ p.4-5)

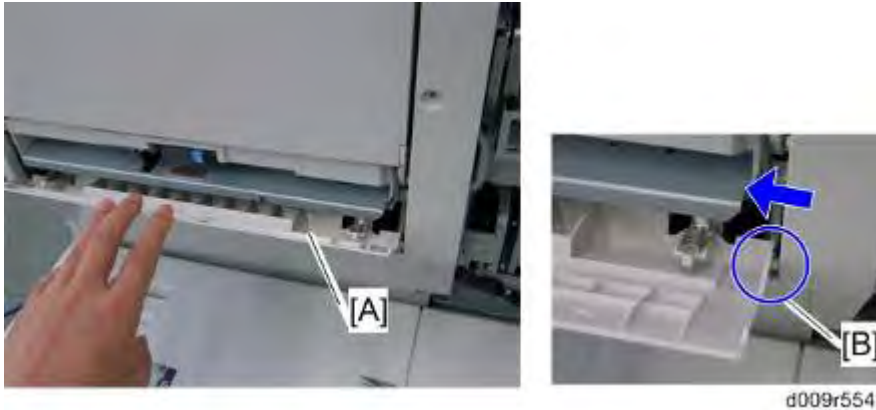

2. Open the lower right cover [A] at the duplex unit.
3. Release the tab [B] and remove the lower door (spring x 2).
4. Open the right door.



5. Release the front link [C] (☛ x 1).



6. Keep the right door fully open.



7. Push up the duplex unit a little bit, while pressing the bracket [D] to lock the spring [E].

**Note**

- Do not let the duplex unit open fully before releasing the wire (step 8). Otherwise, the lock for the spring [E] is released.

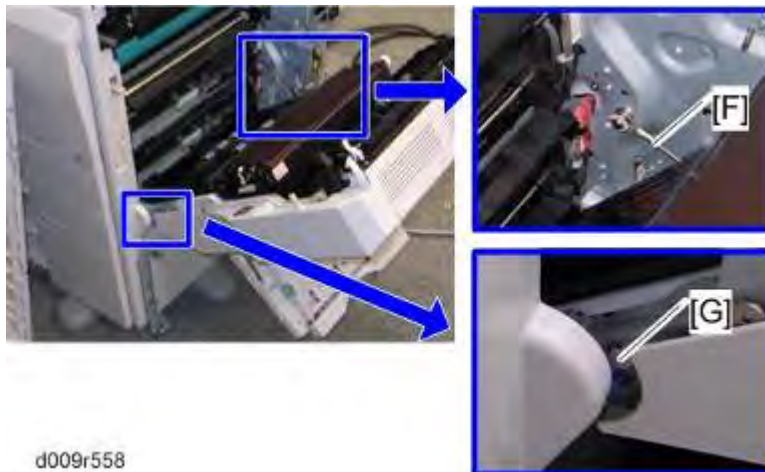

8. Wire [F] (Ⓜ x 1)

9. Push the projection [G].



10. Duplex unit (Ⓜ x 3, Ⓜ x 1, ground cable x 1)

Replacement and Adjustment



## 4.11.2 RIGHT DOOR COVER



m1322087

1. Open the duplex door [A] and by-pass tray.

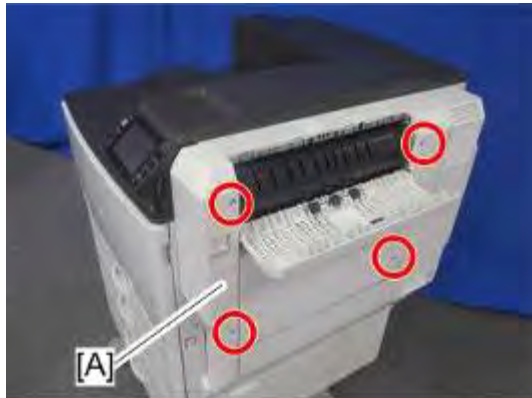

m1322088

2. Right door cover [A] (🔑 x 4)

### 4.11.3 DUPLEX DOOR SENSOR

1. Right door cover (☛ p.4-56)

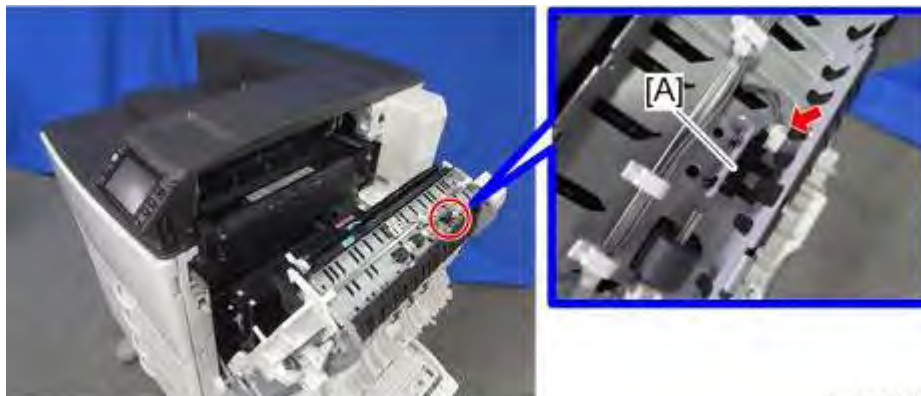

m1322090

2. Duplex door sensor [A] (☛ x 1, hook)

### 4.11.4 DUPLEX ENTRANCE SENSOR

1. Right door cover (☛ p.4-56)
2. Open the right door.

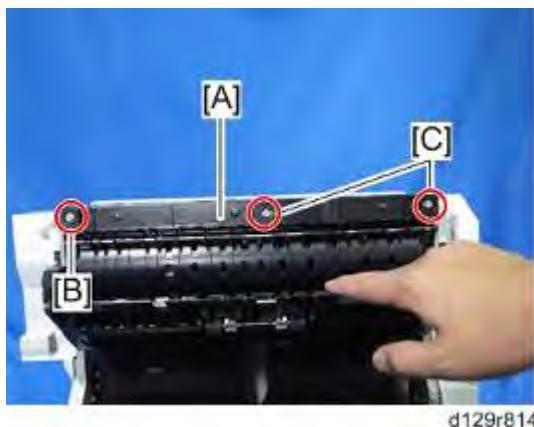

d129r814

3. Duplex entrance guide [A] ([B]: ☛ x 1, [C]: Stepped screw x 2)



d129r815

4. Duplex entrance sensor bracket [A] (☛ x 1, ☛ x 1)

Replacement and Adjustment

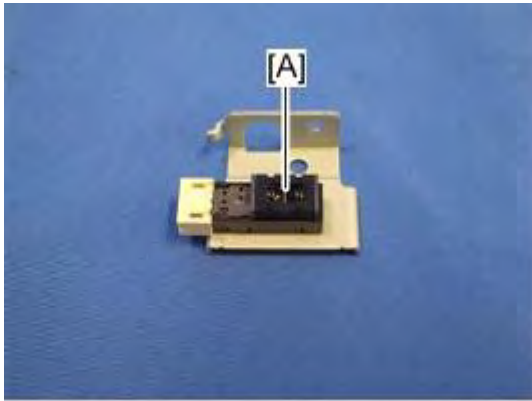

d129r816

5. Duplex entrance sensor [A] (hooks)

### 4.11.5 DUPLEX EXIT SENSOR

1. Transfer belt unit (☛ p.4-28)

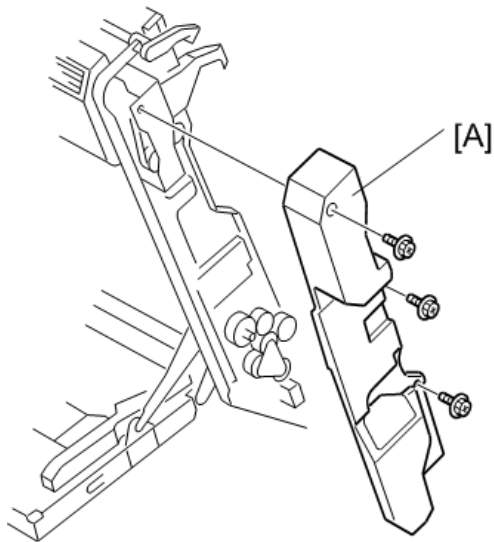

d009r036

2. Right door rear cover [A] (☛ x 3)

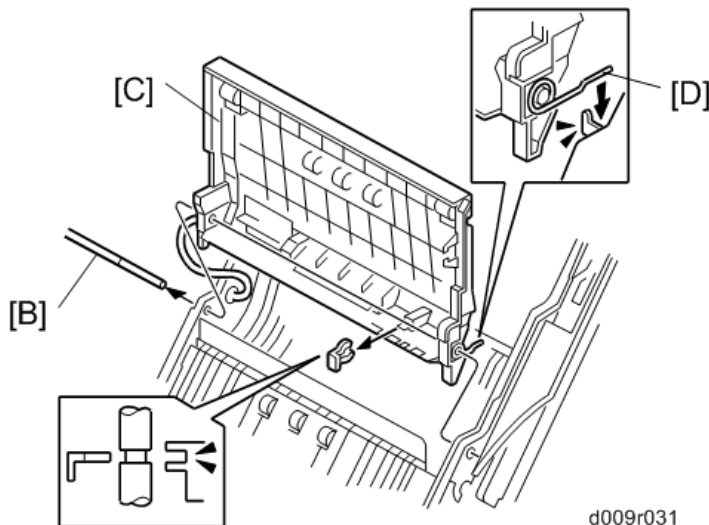

d009r031

3. Remove the shaft [B] (☛ x 1).

4. Transfer belt unit holder [C] (🔌 x 1, 🌀 x 1)

⬇️ **Note**

- When re-installing the transfer belt unit holder, make sure that the spring [D] correctly hooks onto the frame.

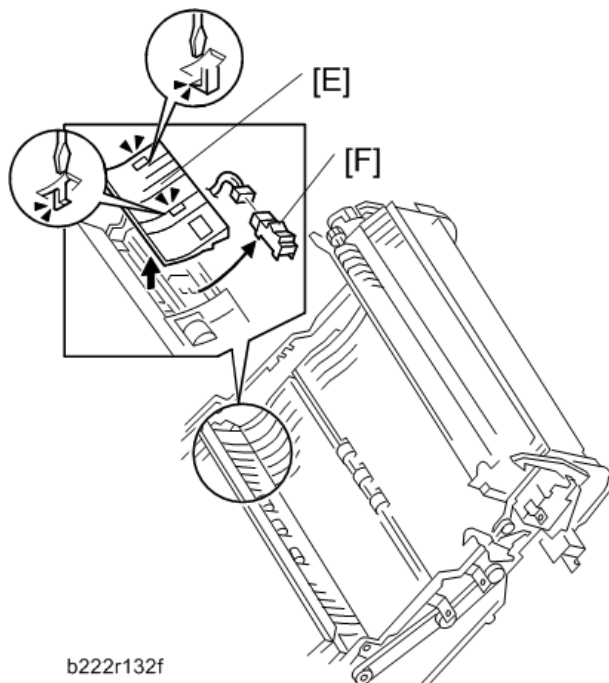

5. Guide plate [E] (two hooks)  
6. Duplex exit sensor [F] (🔌 x 1, hooks)

### 4.11.6 DUPLEX/BY-PASS MOTOR

1. Rear cover (🔩 p.4-4)
2. Right rear cover (🔩 p.4-5)

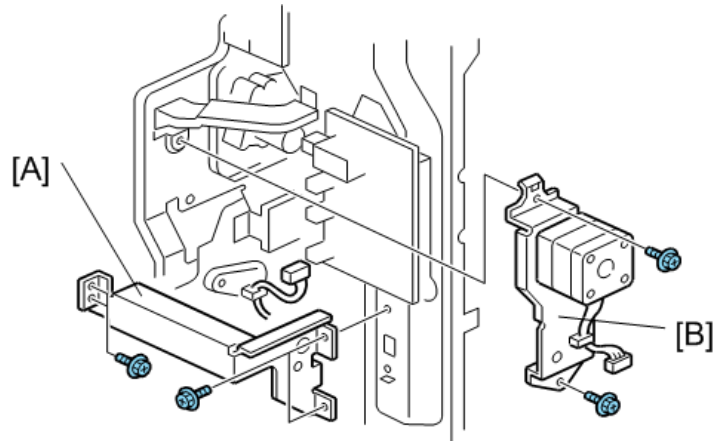

d009r034

3. Frame [A] (🔩 x 4)
4. Duplex/By-pass motor bracket [B] (🔩 x 2, 📏 x 1)

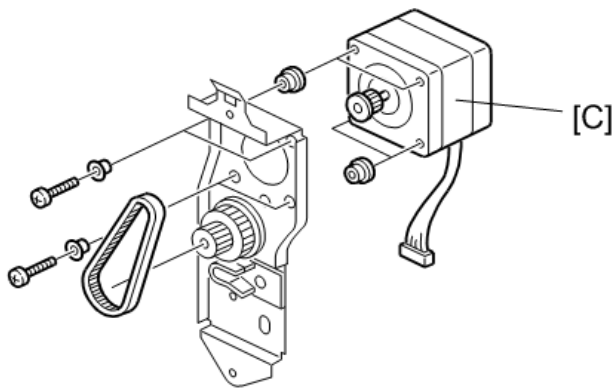

d009r035

5. Duplex/By-pass motor [C] (🔩 x 4, bushing x 8, timing belt x 1)

### 4.11.7 DUPLEX INVERTER MOTOR

1. Right door cover (☛ p.4-56)
2. Open the right door.

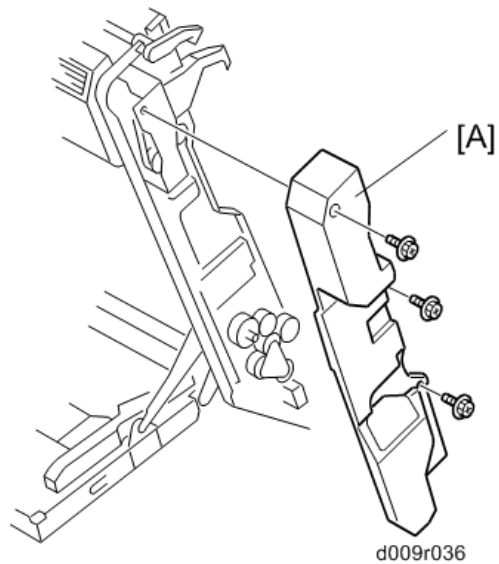

3. Right door rear cover [A] (☛ x 3)

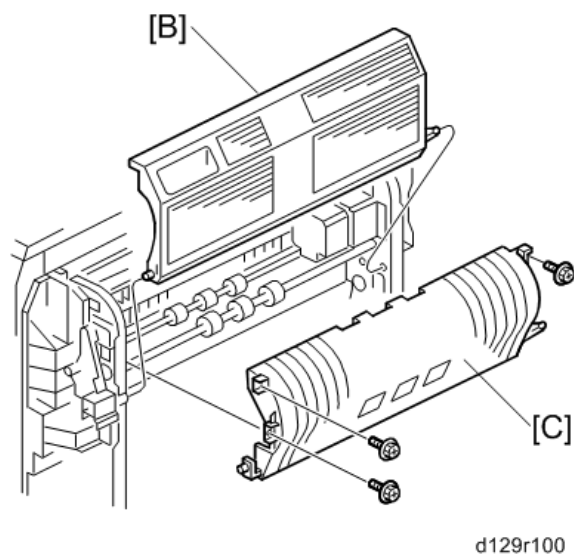

4. Duplex door [B]
5. Duplex guide plate [C] (☛ x 3)

## Duplex

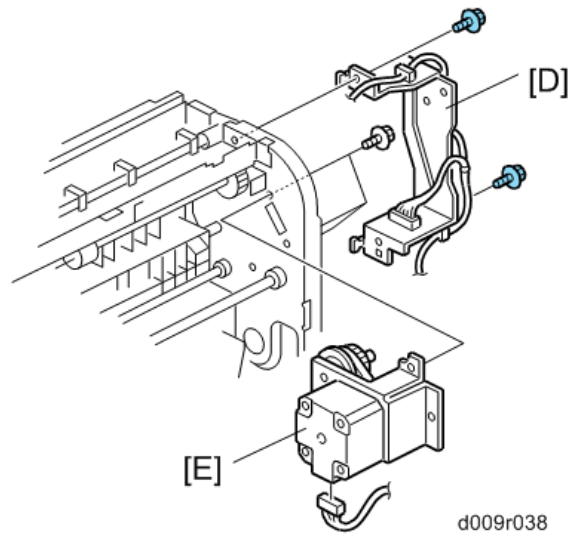

6. Bracket [D] (🔩 x 2)
7. Duplex inverter motor [E] (🔩 x 3, 🍆 x 1)

# 4.12 BY-PASS

## 4.12.1 BY-PASS PAPER SIZE SENSOR/BY-PASS PAPER LENGTH SENSOR

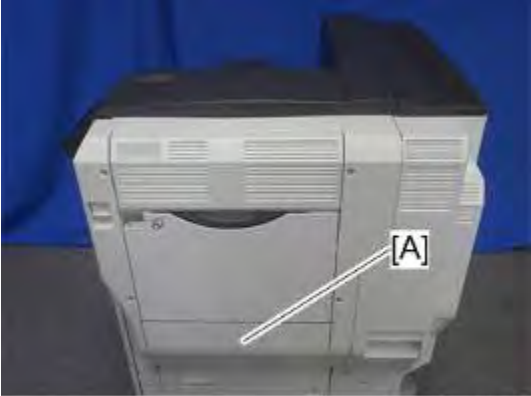

m1322091

- 1. Open the lower right cover [A].

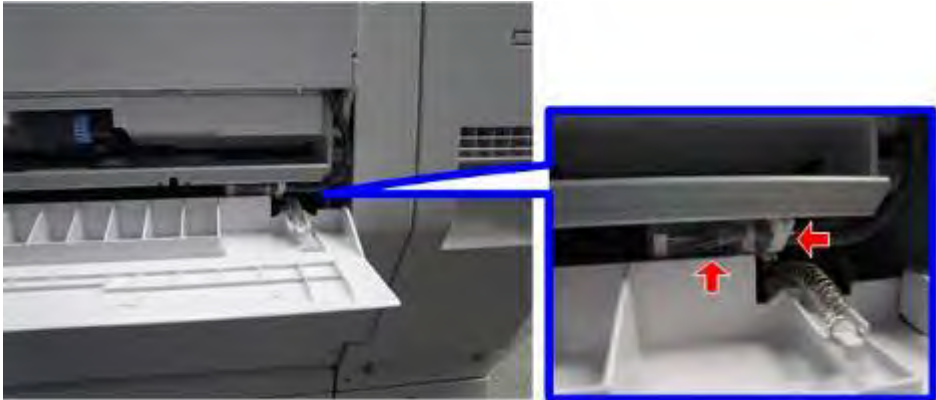

d129r808

- 2. Disconnect the connector and clamp.



m1322092

- 3. Open the by-pass tray [A].

Replacement and Adjustment



## By-pass

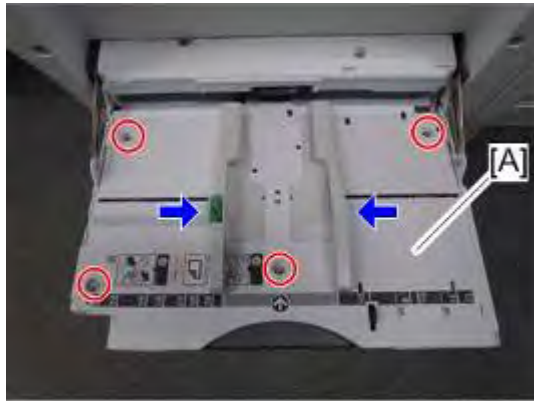

4. Move the side fences to the center.
5. By-pass tray cover [A] (🔑 x 4)

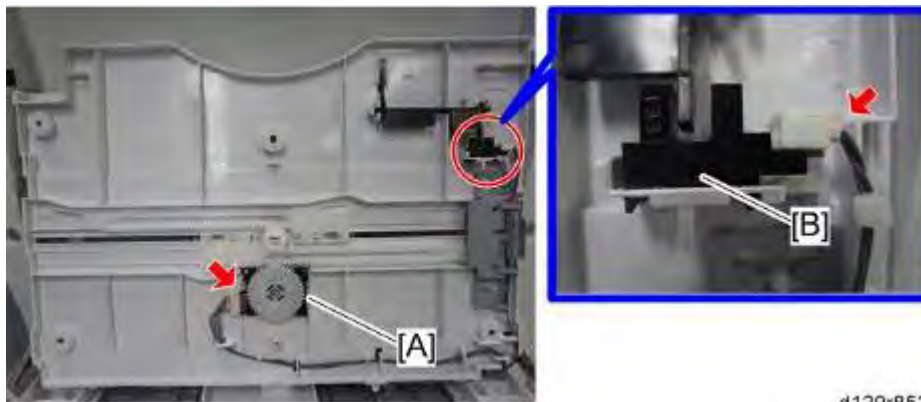

6. By-pass paper size sensor [A] (🔑 x 1)
7. By-pass paper length sensor [B] (🔑 x 1)

### When reinstalling the by-pass paper size sensor

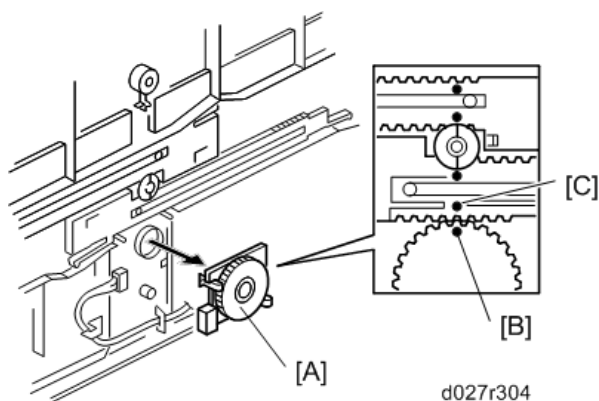

1. Adjust the projection [A] of the left side fence bar (it must be centered).
2. Install the by-pass paper size detection switch so that the hole [B] in this switch faces the projection [C] of the left side fence bar.
3. Reassemble the machine.
4. Plug in and turn on the main power switch.
5. Check this switch operation with SP5803-024 (By-pass: Paper Size Sensor< Input Check).

#### - Display on the LCD -

Paper Size	Display	Paper Size	Display
A3 SEF	00001110	A5 SEF	00001011
B4 SEF	00001100	B6 SEF	00000011
A4 SEF	00001101	A6 SEF	00000111
B5 SEF	00001001	Smaller A6 SEF	00001111

## 4.12.2 BY-PASS PAPER END SENSOR

1. Right door cover (☛ p.4-56)

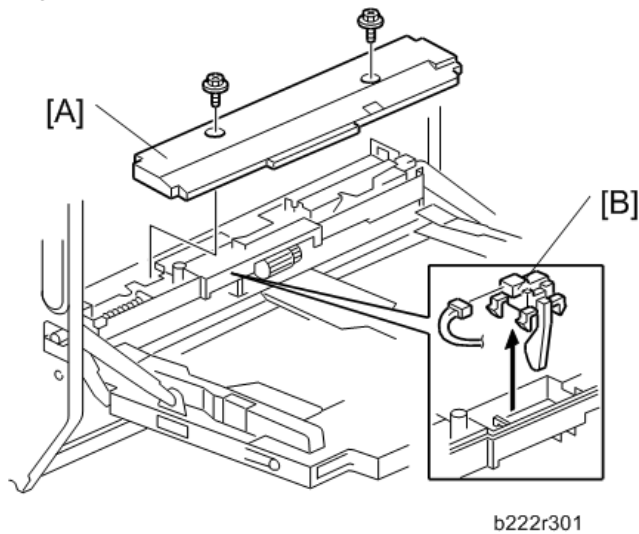

2. By-pass feed unit cover [A] (☛ x 2).
3. By-pass paper end sensor [B] (☛ x 1, hooks)

## 4.12.3 BY-PASS PICK-UP, FEED AND SEPARATION ROLLER, TORQUE LIMITER

1. Right door cover (☛ p.4-56)
2. By-pass feed unit cover (☛ p.4-66 "By-pass Paper End Sensor")

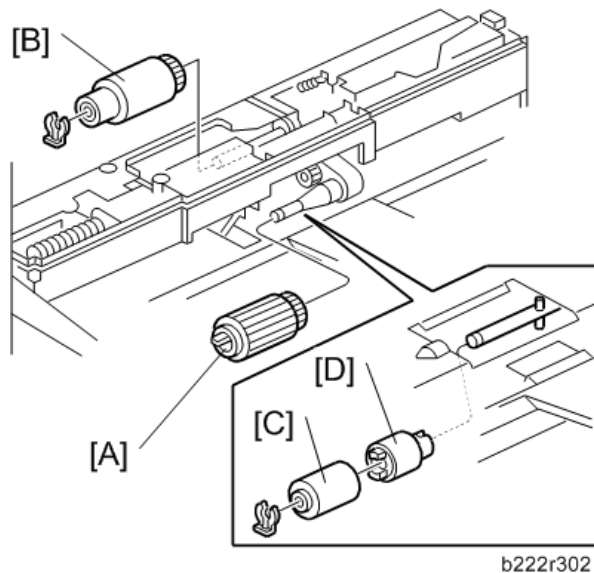

3. By-pass pick-up roller [A] (hook)
4. By-pass feed roller [B] (☛ x 1)
5. By-pass separation roller [C] (☛ x 1)
6. Torque limiter [D]

#### 4.12.4 BY-PASS FEED CLUTCH

1. Open the right door.
2. Right door rear cover (🔧 p.4-58 "Duplex Exit Sensor")
3. Transfer belt unit (🔧 p.4-28)
4. Transfer belt unit holder (🔧 p.4-58 "Duplex Exit Sensor")

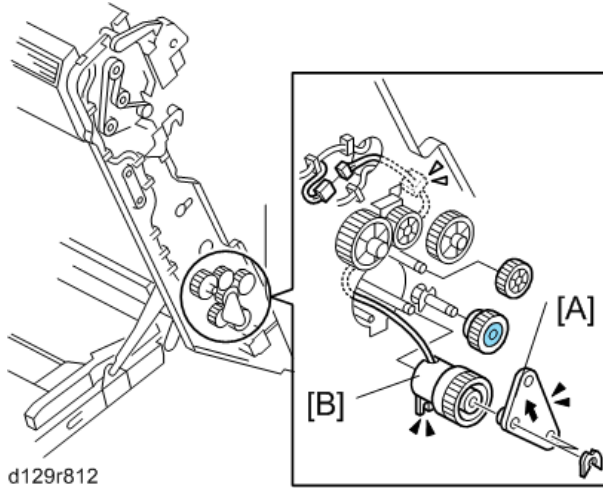

5. By-pass feed clutch holder [A] (🔧 x 2)
6. By-pass feed clutch [B] (🔧 x 1, 🔧 x 1)

## 4.13 DRIVE AREA

### 4.13.1 PAPER FEED CLUTCH

#### Tray 1 and Tray 2

1. Rear cover (☛ p.4-4)

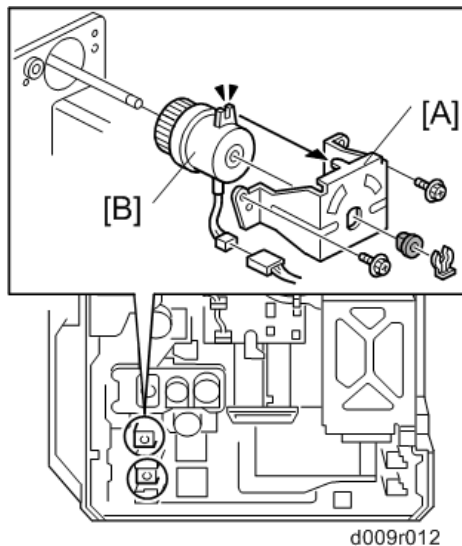

2. Clutch bracket [A] (☛ x 2, ☛ x 1, bushing x 1)
3. Paper feed clutch [B] (☛ x 1)

### 4.13.2 DEVELOPMENT PADDLE MOTOR

1. Rear cover (☛ p.4-4)

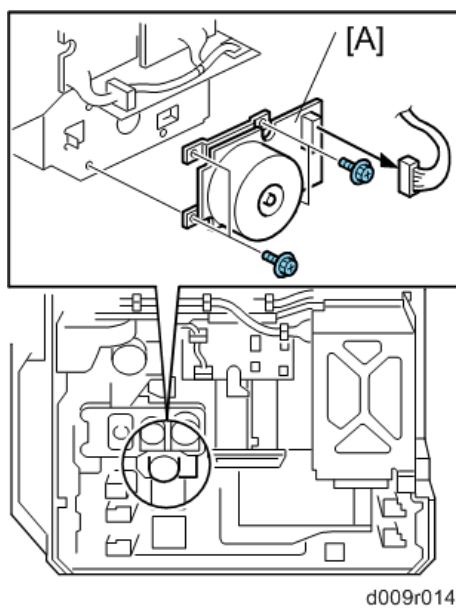

2. Development paddle motor [A] (☛ x 4, ☛ x 1)

### 4.13.3 TRANSFER/DEVELOPMENT MOTOR

1. Rear cover (🔧 p.4-4)

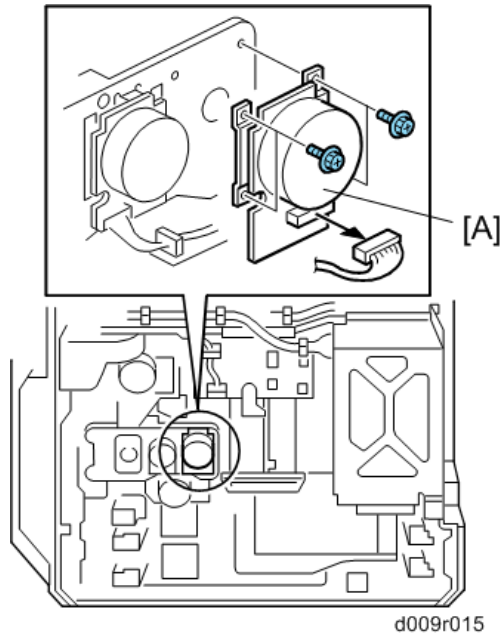

2. Transfer/development motor [A] (🔧 x 4, 📦 x 1)

### 4.13.4 DRUM MOTOR

1. Rear cover (🔧 p.4-4)

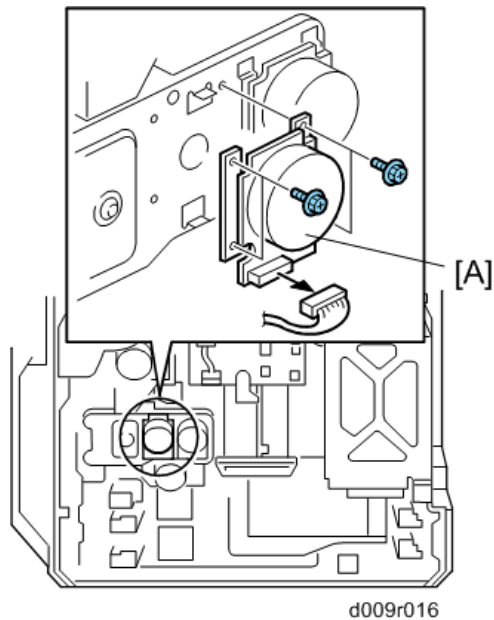

2. Drum motor [A] (🔧 x 4, 📦 x 1)

Replacement  
and  
Adjustment

### 4.13.5 FUSING MOTOR

1. Rear cover (🔧 p.4-4)

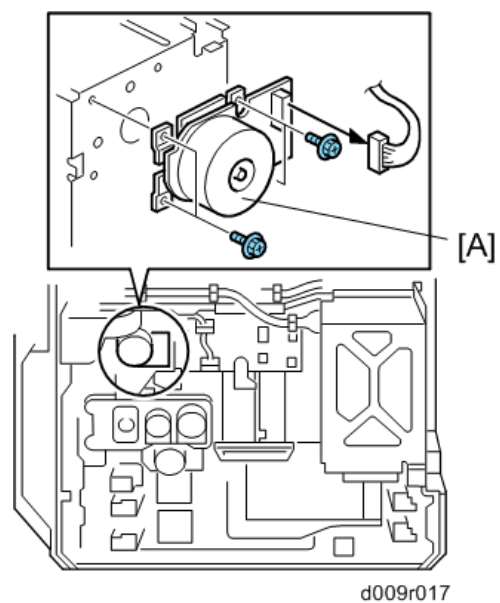

2. Fusing motor [A] (🔧 x 4, 📦 x 1)

### 4.13.6 WEB MOTOR

1. Rear cover (🔧 p.4-4)

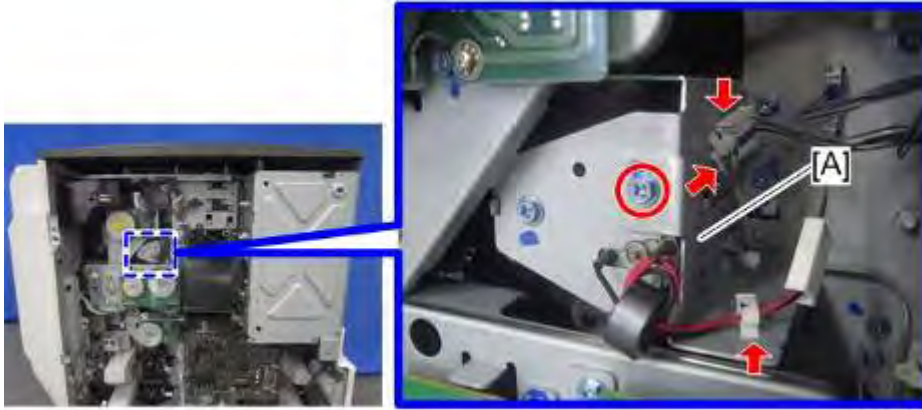

m1322093

2. Bracket [A] (🔧 x 1, 🛠️ x 2, 🛠️ x 1)

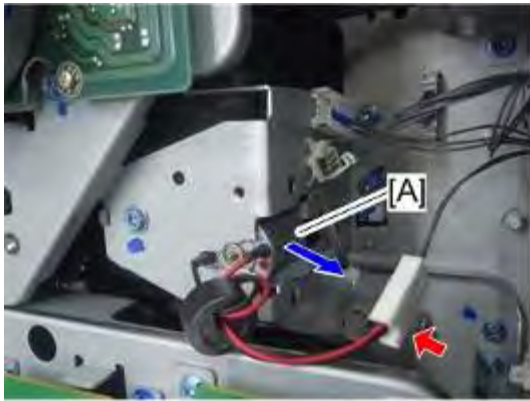

m1322094

3. Web motor [A] (🛠️ x 1)

Replacement  
and  
Adjustment



### 4.13.7 PAPER FEED MOTOR

1. Rear cover (🔧 p.4-4)
2. Right rear cover (🔧 p.4-5)

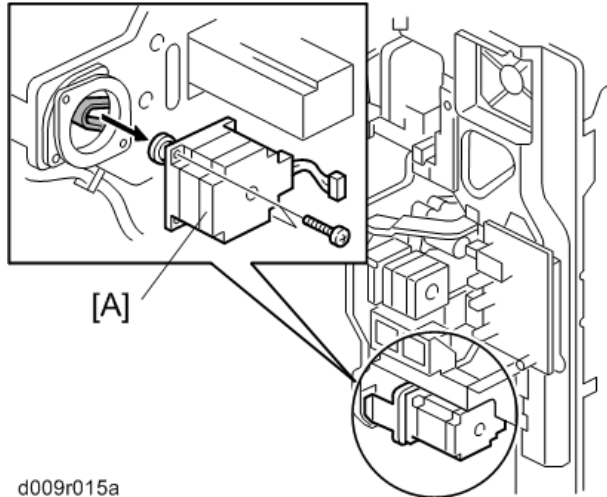

d009r015a

3. Paper feed motor [A] (🔧 x 2, 📦 x 1)

### 4.13.8 TRANSFER BELT CONTACT MOTOR

1. Rear cover (🔧 p.4-4)
2. Right rear cover (🔧 p.4-5)

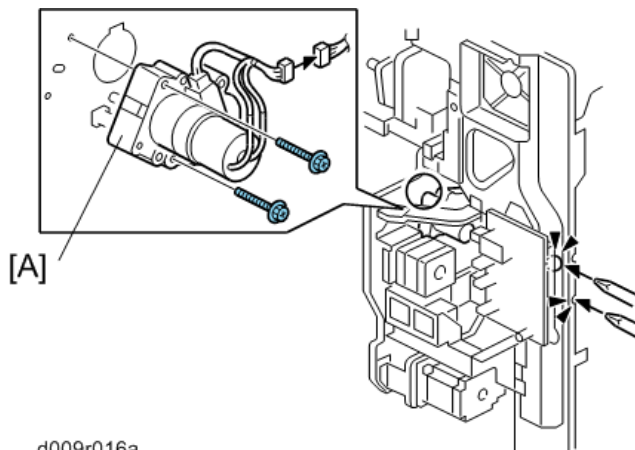

d009r016a

3. Transfer belt contact motor [A] (🔧 x 2, 📦 x 1)

### 4.13.9 REGISTRATION MOTOR

1. Rear cover (☛ p.4-4)
2. Right rear cover (☛ p.4-5)

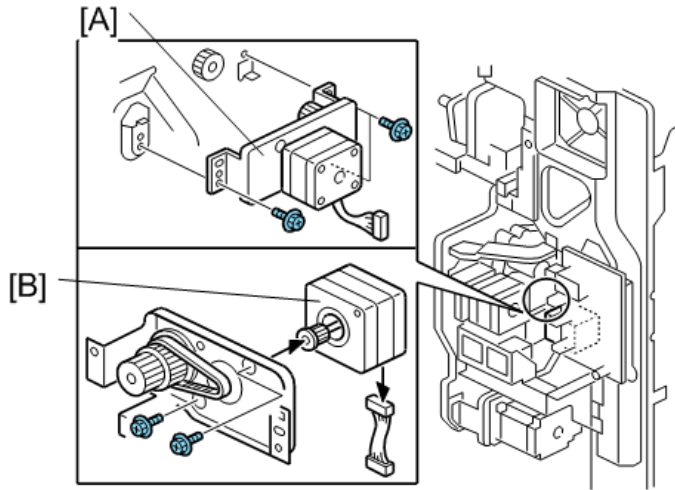

d009r017a

3. Registration motor bracket [A] (☛ x 3, ☛ x 1)
4. Registration motor [B] (☛ x 2, ☛ x 1)

Replacement  
and  
Adjustment

### 4.13.10 TONER SUPPLY MOTOR

1. Left cover (🔩 p.4-4)
2. Upper inner cover (🔩 p.4-3 "Front Door, Upper and Lower Inner Cover")
3. Output Tray (🔩 p.4-8)

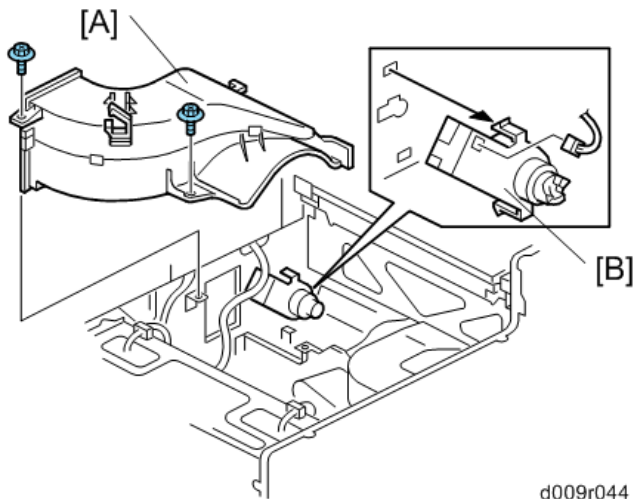

d009r044

4. Exhaust duct [A] (🔩 x 2)
5. Toner supply motor [B] (hooks, 📌 x 1)

## 4.14 ELECTRICAL COMPONENTS

### 4.14.1 CONTROLLER UNIT



1. Controller unit [A] (🔑 x 2)

### 4.14.2 CONTROLLER BOARD

#### ⚠ CAUTION

- The battery on the control board can explode if replaced incorrectly.
- Dispose of the old battery in accordance with the instructions.

#### ***Before Replacing the Controller Board in the Model without HDD***

When you replace the controller board in a machine without a HDD, address book data can be copied from an old controller board to a new controller board using an SD card.

Copy the address book data to an SD card from the flash ROM on the controller board with **SP5846-051** if possible.

#### ***Replacement Procedure***

1. Controller unit (🔑 p.4-75)
2. HDD unit (if it has been installed.)

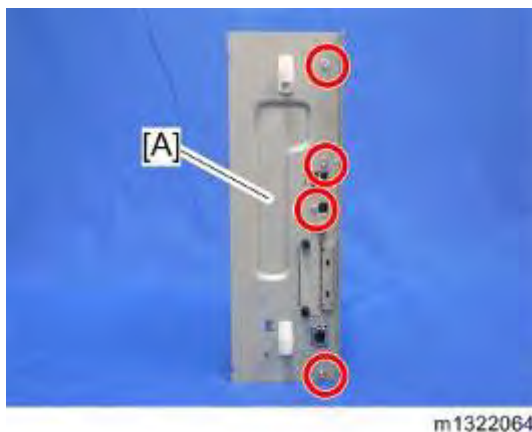

## Electrical Components

3. Controller right bracket [A] (⚙️ x 4)

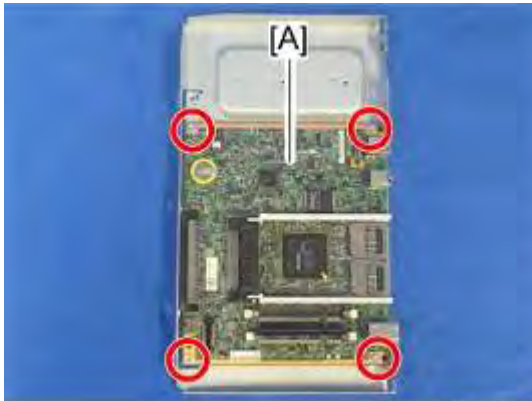

4. Controller board assembly [A] (⚙️ x 4)

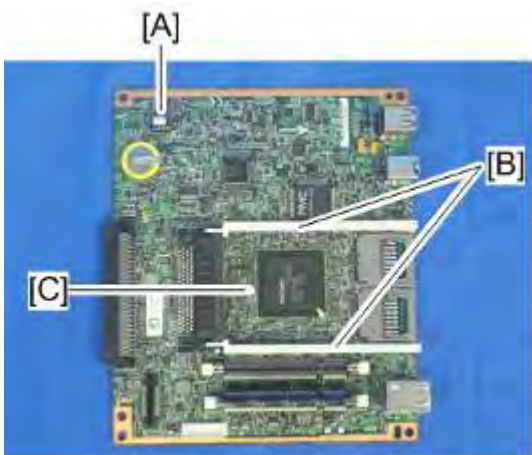

5. NVRAM [A]
6. Interface rails [B] (hooks each)
7. DIMM-RAM (If it is installed.)
8. Controller board [C]

### When Installing the New Controller Board

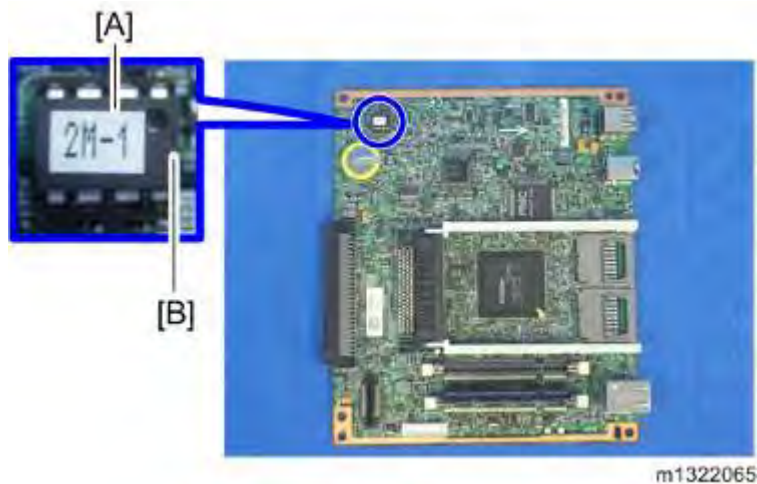

1. Remove the NVRAM [A] from the old controller board.
2. Install it on the new controller board after you replace the controller board.
3. Replace the NVRAM if the NVRAM on the old controller board is defective.

#### ↓ Note

- Make sure the NVRAM is correctly installed on the controller board. Insert the NVRAM in the NVRAM slot with the “half-moon” pointing [B] to the right side.
- Make sure you print out the SMC reports ("SP (Mode Data List)" and "Logging Data") before you replace the NVRAM.

#### ⚠ CAUTION

- Keep NVRAM away from any objects that can cause static electricity. Static electricity can damage NVRAM data.
- Make sure the NVRAM is correctly installed on the controller board.
- Make sure that the DIP-switch settings on the old controller board are the same for the new controller board. Do not change the DIP switches on the controller board in the field.

### 4.14.3 AFTER INSTALLING THE CONTROLLER BOARD

1. For a model without a HDD, do **SP5846-052** to copy back the address book to the flash ROM on the controller board from the SD card to which you have already copied the address book data if possible.
2. If the customer is using the data encryption feature, the encryption key must be restored.
3. Do the touch screen calibration. (☛ p.4-92 "Touch Screen Calibration")
4. Turn the main power switch off/on.

### 4.14.4 MOTHER BOARD

1. Rear cover (🔩 p.4-4)
2. Controller unit (🔩 p.4-75)

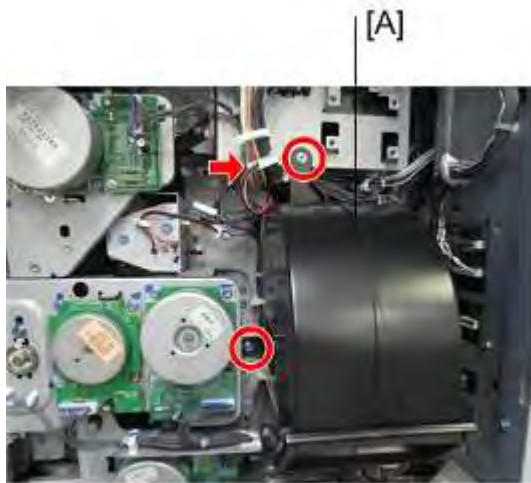

d129r104

3. Exhaust fan duct [A] (🔩 x 2, 📏 x 1)

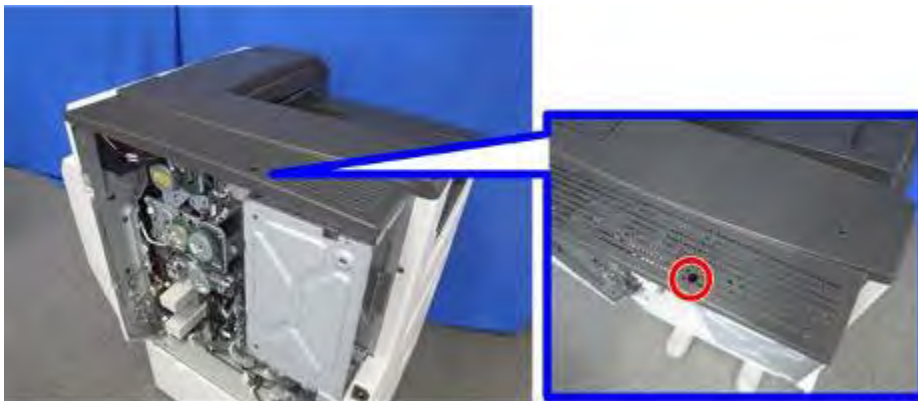

m1322063

4. Screw of the top rear cover (🔩 x 1)



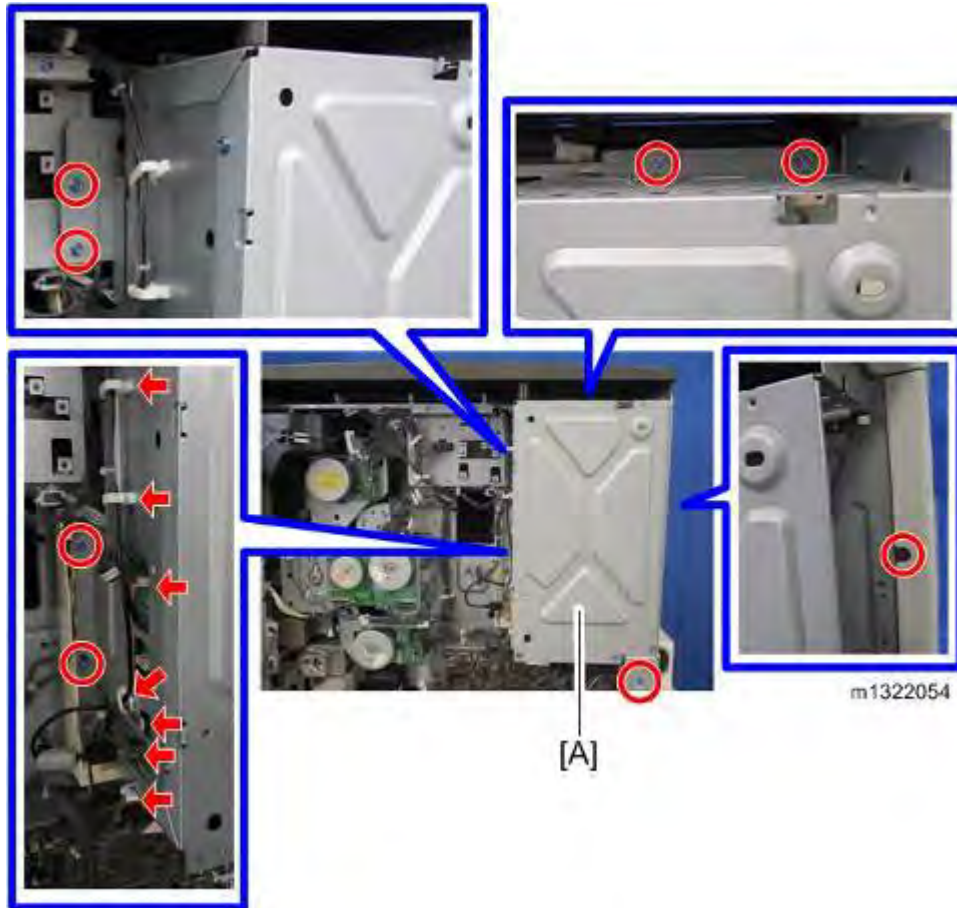

5. Controller box [A] (🔩 x 8, 🛠️ x 4, 🛠️ x 3)

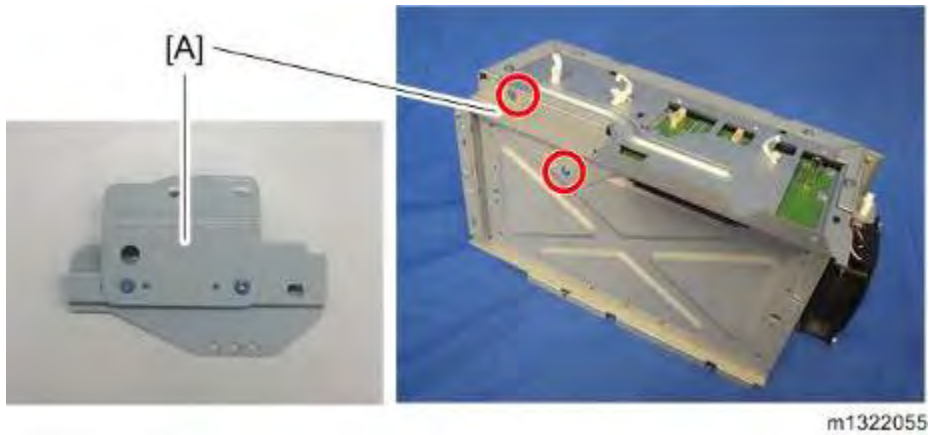

6. Controller light bracket [A] (🔩 x 2)

Replacement and Adjustment



## Electrical Components

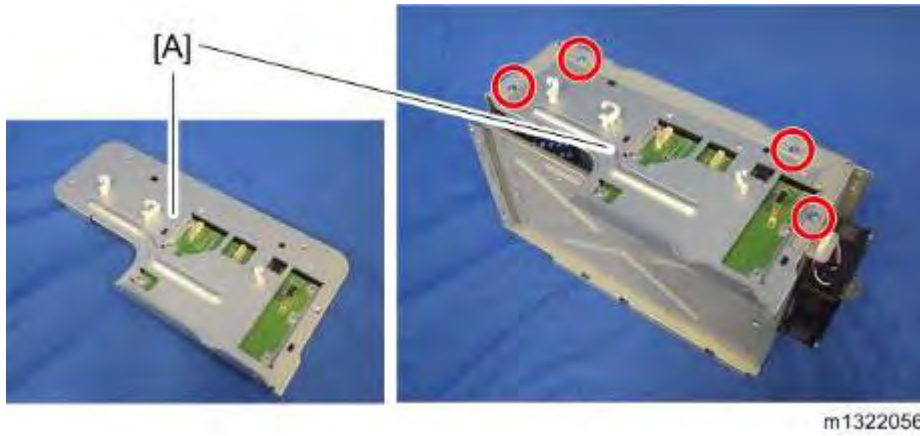

7. Controller box right cover [A] (🔩 x 4)

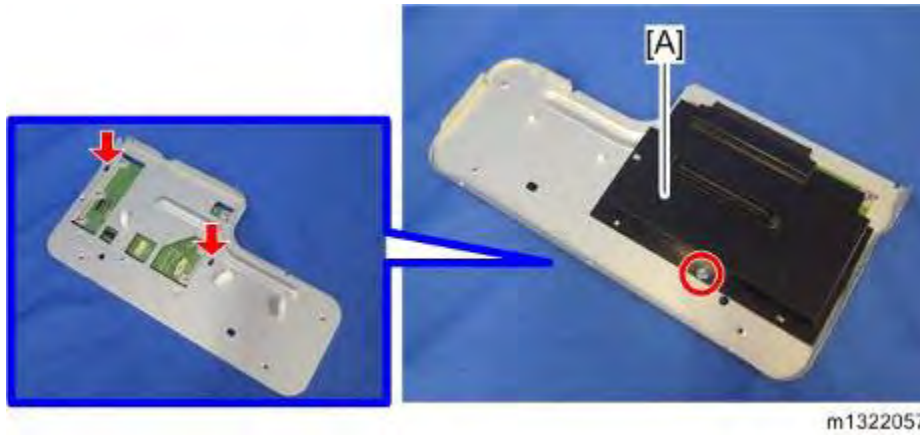

8. Mother board bracket [A] (🔩 x 1, hook x 2)

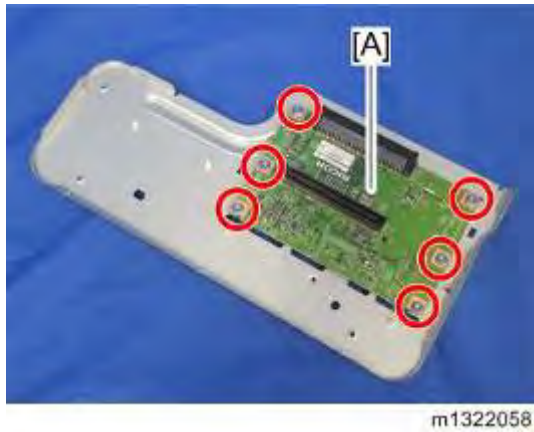

9. Mother board [A] (🔩 x 6)

### 4.14.5 BCU

1. Controller box (👉 p.4-78 "Mother Board")

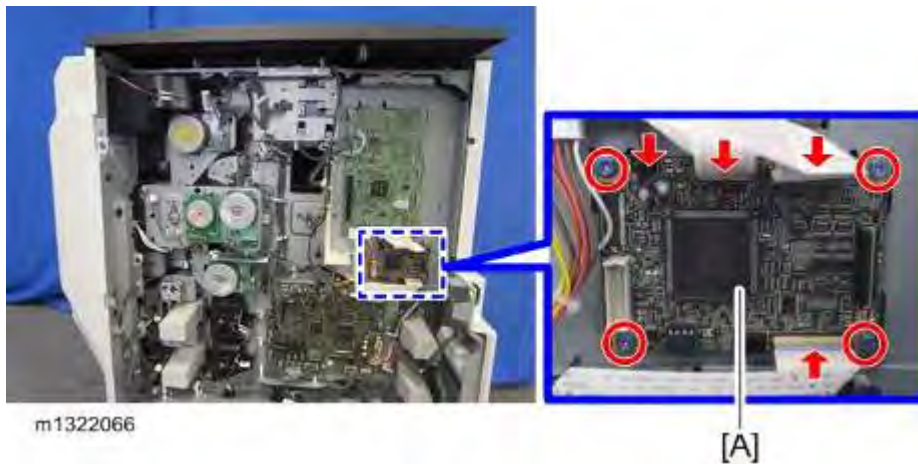

2. BCU [A] (🔑 x 4, 📁 x 4)

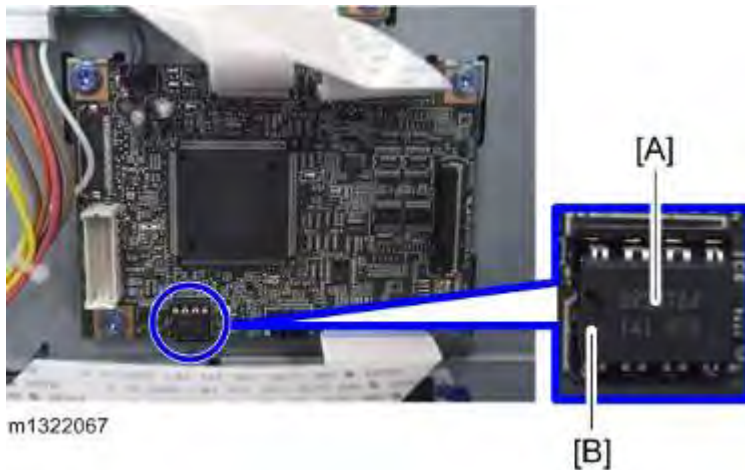

3. Remove the NVRAM [A] from the old board and install it on the new board.
4. Set the DIP switches on the new BCU board to the same settings as the old board.

**Note**

- Make sure the NVRAM is correctly installed on the BCU. Insert the NVRAM in the NVRAM slot with the "half-moon" pointing [B] to the left side.

#### ***When installing the new BCU***

1. Remove the NVRAM from the old BCU.
2. Install the NVRAM on the new BCU after you replace the BCU.
3. Reassemble the machine.
4. Turn on the main power switch.
5. Enter the serial number with SP5-811-004.
6. Turn the main power switch off and on.
7. Do the touch screen calibration. (👉 p.4-92 "Touch Screen Calibration")

**Note**

- Make sure you print out the SMC reports ("SP (Mode Data List)" and "Logging Data") before you replace the NVRAM.

**CAUTION**

- Keep NVRAM away from any objects that can cause static electricity. Static electricity can damage NVRAM data.

### 4.14.6 BRIDGE BOARD

1. Controller box (☛ p.4-78 "Mother Board")

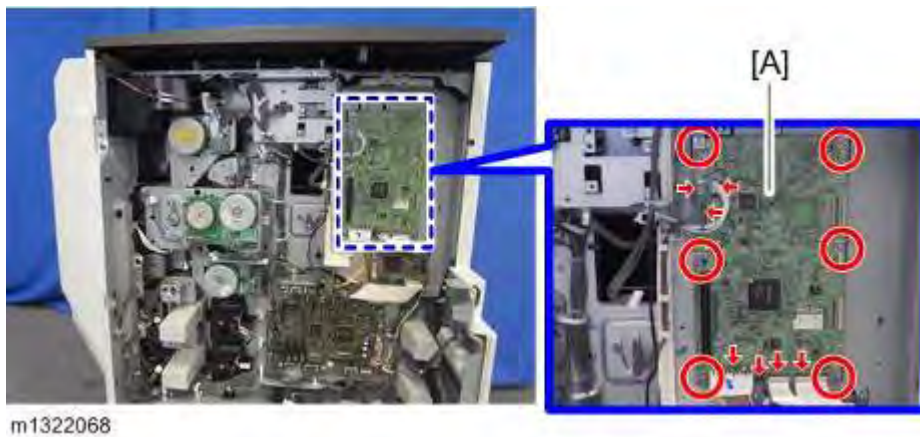

2. Bridge board [A] (☛ x 6, ☛ x 7)

### 4.14.7 IOB

1. Rear cover (☛ p.4-4)

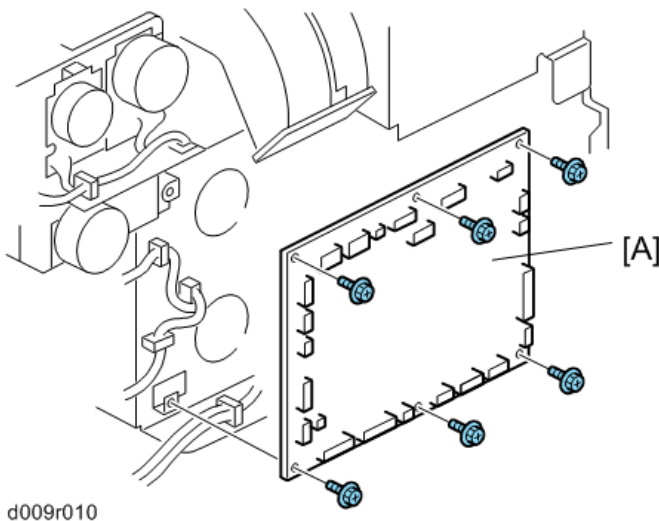

2. IOB [A] (☛ x 6, ☛ x all)

### 4.14.8 PSU

1. Left cover (🔧 p.4-4)

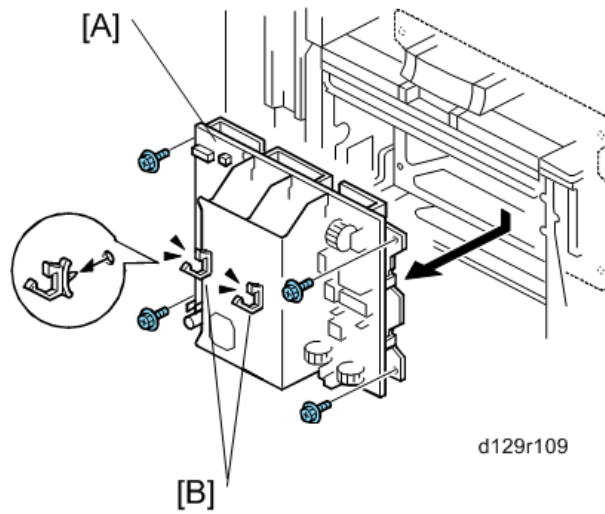

2. PSU [A] (🔧 x 4, 🛠️ x all)
3. Two clamps [B] (These clamps will be used for the new PSU.)

### 4.14.9 HIGH VOLTAGE POWER SUPPLY

1. Rear cover (🔧 p.4-4)
2. Right rear cover (🔧 p.4-5)

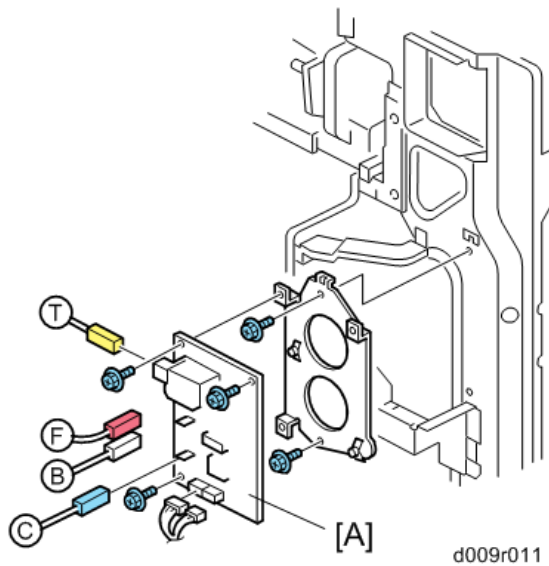

3. High voltage power supply board [A] (🔧 x 5, 🛠️ x all)

### 4.14.10 FUSING EXHAUST FAN

1. Rear cover (☛ p.4-4)

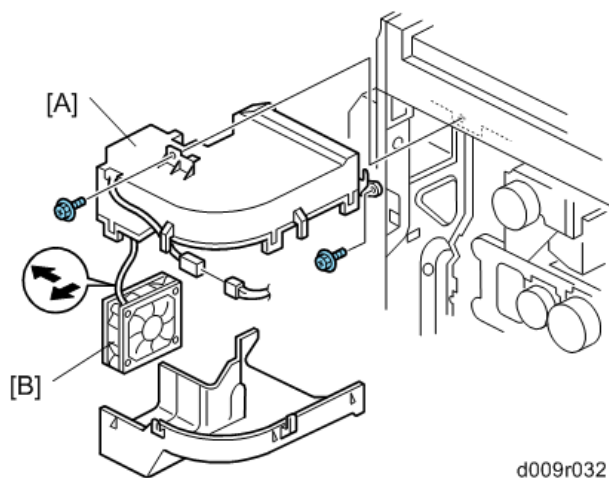

2. Fusing exhaust duct [A] (☛ x 2, ☛ x 1)
3. Separate the duct (hooks).
4. Fusing exhaust fan [B]

#### ***When installing the fusing exhaust fan***

Make sure that the fusing fan is installed with its decal facing the right side of the machine.

### 4.14.11 CONTROLLER FAN

1. Controller box (☛ p.4-78 "Mother Board")

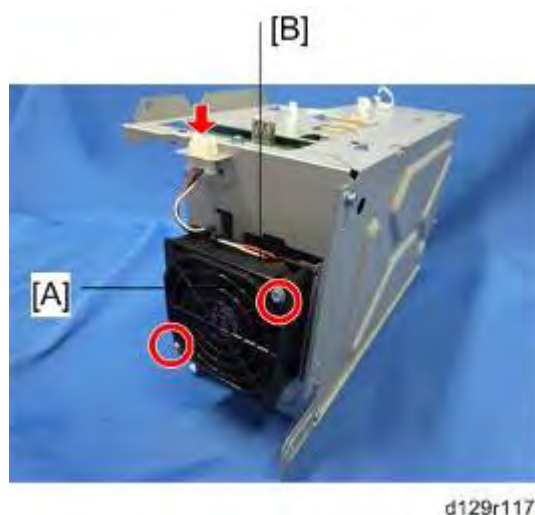

2. Fan cover [A] (☛ x 2)
3. Controller fan [B] (☛ x 1)

#### ***When installing the controller fan***

Make sure that the controller fan is installed with its decal facing upward.



### 4.14.12 SD USB BOARD

1. Operation panel (🔧 p.4-6)

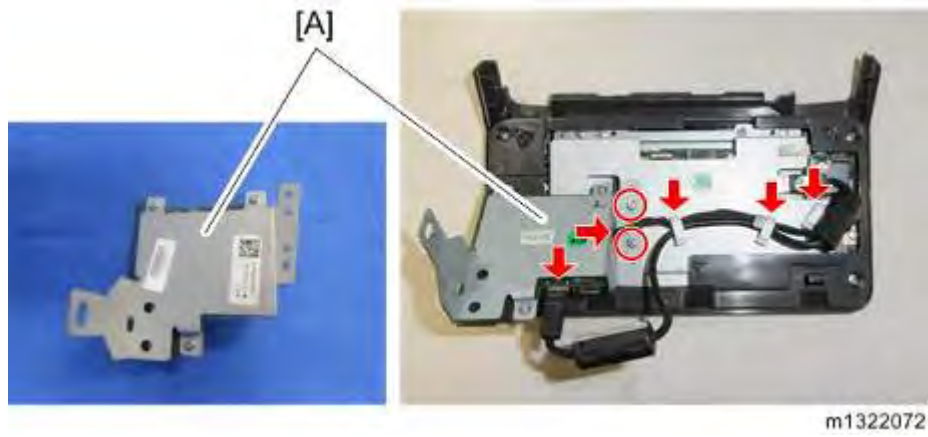

2. SD USB board bracket [A] (small 🔧 x 2, 📏 x 2, 📏 x 3)

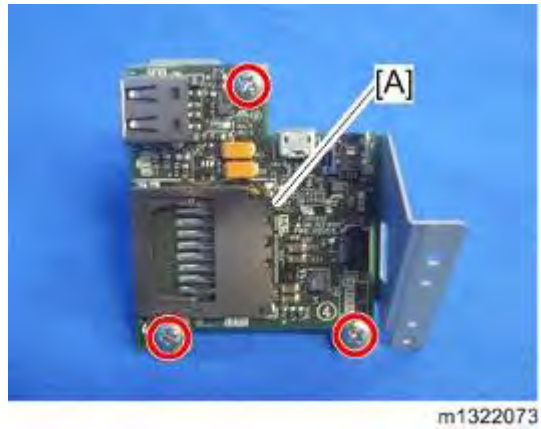

3. SD USB board [A] (🔧 x 3)

Replacement and Adjustment

### 4.14.13 LCDC BOARD

1. SD USB Board (🔑 p.4-85)

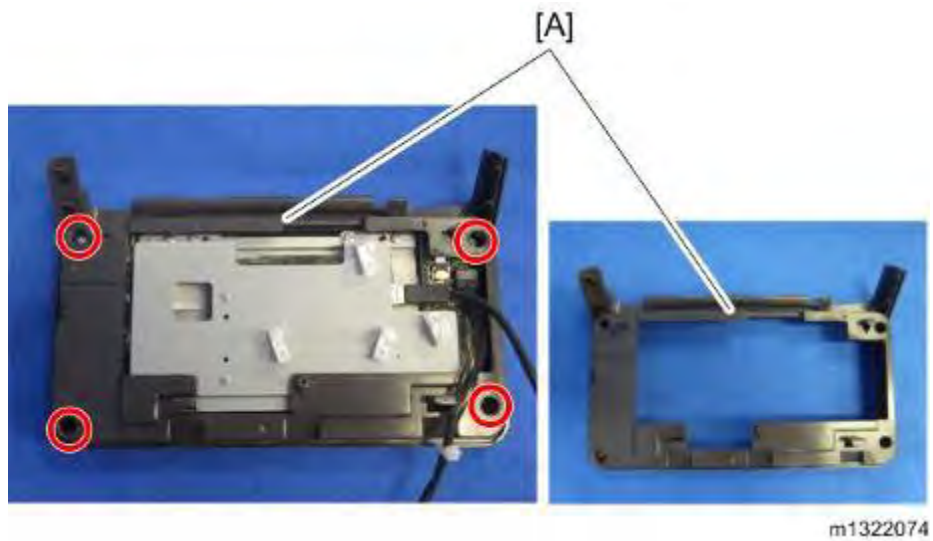

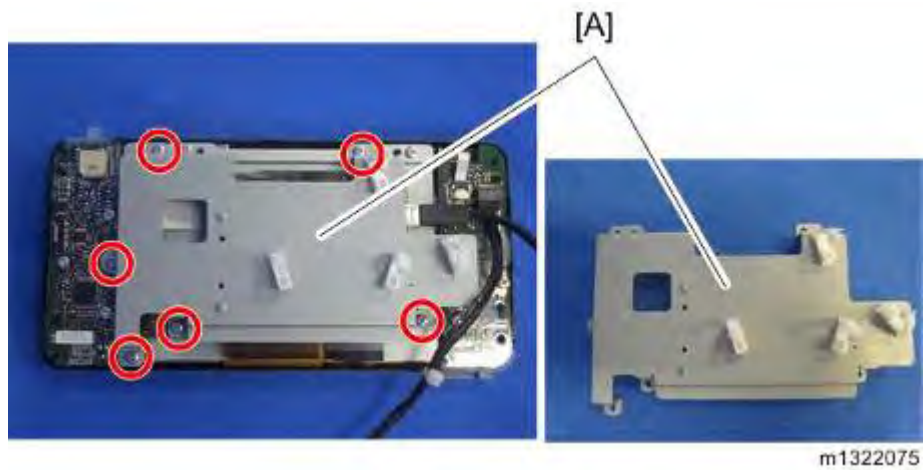

2. Operation panel inner bracket [A] (small 🔑 x 4)

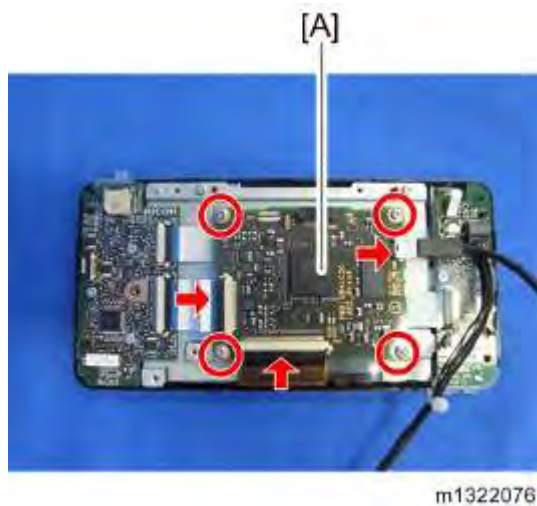

3. LCDC bracket [A] (small 🔑 x 6)



4. LCDC board [A] (small  x 4,  x 3)

***When Installing the New LCDC Board***

Do the touch screen calibration after you replace the LCDC board. ( p.4-92 "Touch Screen Calibration")



## 4.15 PRINT ADJUSTMENTS

### 4.15.1 OVERVIEW

Perform these adjustments after replacing any of the following:

- Polygon Mirror Motor
- Paper Side Fence
- Memory All Clear

### 4.15.2 PRINTING

1. Make sure paper is installed correctly in each paper tray before you start these adjustments.
2. Use the Trimming Area Pattern (SP2-109-1, No. 14) to print the test pattern for the following procedures.

#### ***Registration - Leading Edge/Side-to-Side***

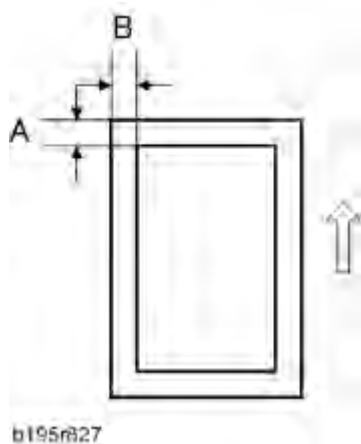

1. Check the leading edge registration [A] for each paper type and paper feed station, and adjust it with following SP modes.

	SP No.	Specification
Tray: Plain	SP1-001-1	0 ±9.0 mm
Tray: Thick 1	SP1-001-2	
Tray: Thick 2	SP1-001-3	
By-pass: Plain	SP1-001-4	
By-pass: Thick 1	SP1-001-5	

	SP No.	Specification
By-pass: Thick 2	SP1-001-6	
Duplex: Plain	SP1-001-7	
Duplex: Thick 1	SP1-001-8	

2. Check side-to-side registration [B] for each paper feed station, and adjust with the following SP modes.

	SP No.	Specification
By-pass	SP1-002-1	0 ±4.0 mm
Tray 1	SP1-002-2	
Tray 2	SP1-002-3	
Tray 3	SP1-002-4	
Tray 4	SP1-002-5	
LCT	SP1-002-6	
Duplex	SP1-002-7	

Replacement  
and  
Adjustment

### Blank Margin

**Note**

- If the leading edge/side-to-side registration cannot be adjusted within specifications, adjust the leading/left side edge blank margin.

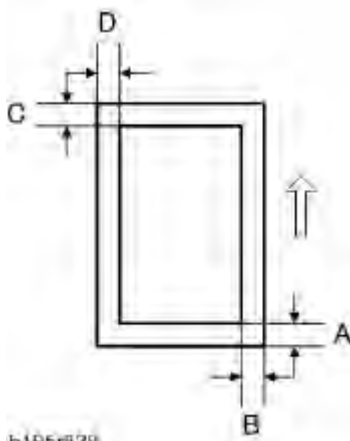

b195r828

## Print Adjustments

1. Check the trailing edge [A], right edge [B], leading edge [C] and left edge [D] blank margins, and adjust them with the following SP modes.

	SP No.	Specification
Leading Edge	SP2-103-1	3.0 mm [0.0 to 9.0 mm]
Trailing Edge	SP2-103-2	
Left	SP2-103-3	2.0 mm [0.0 to 9.0 mm]
Right	SP2-103-4	
Duplex: Trailing Edge: L Size: Plain	SP2-103-5	1.0 mm [0.0 to 4.0 mm]
Duplex: Trailing Edge: M Size: Plain	SP2-103-6	0.8 mm [0.0 to 4.0 mm]
Duplex: Trailing Edge: S Size: Plain	SP2-103-7	0.6 mm [0.0 to 4.0 mm]
Duplex: Left: Plain	SP2-103-8	0.3 mm [0.0 to 1.5 mm]
Duplex: Right: Plain	SP2-103-9	
Duplex: Trailing Edge: L Size: Thick	SP2-103-10	0.8 mm [0.0 to 4.0 mm]
Duplex: Trailing Edge: M Size: Thick	SP2-103-11	0.6 mm [0.0 to 4.0 mm]
Duplex: Trailing Edge: S Size: Thick	SP2-103-12	0.4 mm [0.0 to 4.0 mm]
Duplex: Left: Thick	SP2-103-13	0.1 mm [0.0 to 1.5 mm]
Duplex: Right: Thick	SP2-103-14	

- L Size: Paper length is 297.1 mm or more.
- M Size: Paper length is 216.1 to 297 mm
- S Size: Paper length is 216 mm or less.

### Main Scan Magnification

1. Use SP2-109-001 no 5 (Grid Vertical Line) to print a single dot pattern.
2. Check magnification, and then SP2-102-001 (Magnification Adjustment Main Scan) to adjust magnification if required. Specification:  $\pm 1\%$ .

### Parallelogram Image Adjustment

Do the following procedure if a parallelogram prints while adjusting the printing registration or printing margin using a trimming area pattern.

The following procedure should be done after adjusting the side-to-side registration for each paper tray station.

Use SP2-109-001 No. 14 (Trimming Area) to determine whether a parallelogram image appears.

If the parallelogram pattern appears, perform the following procedure.

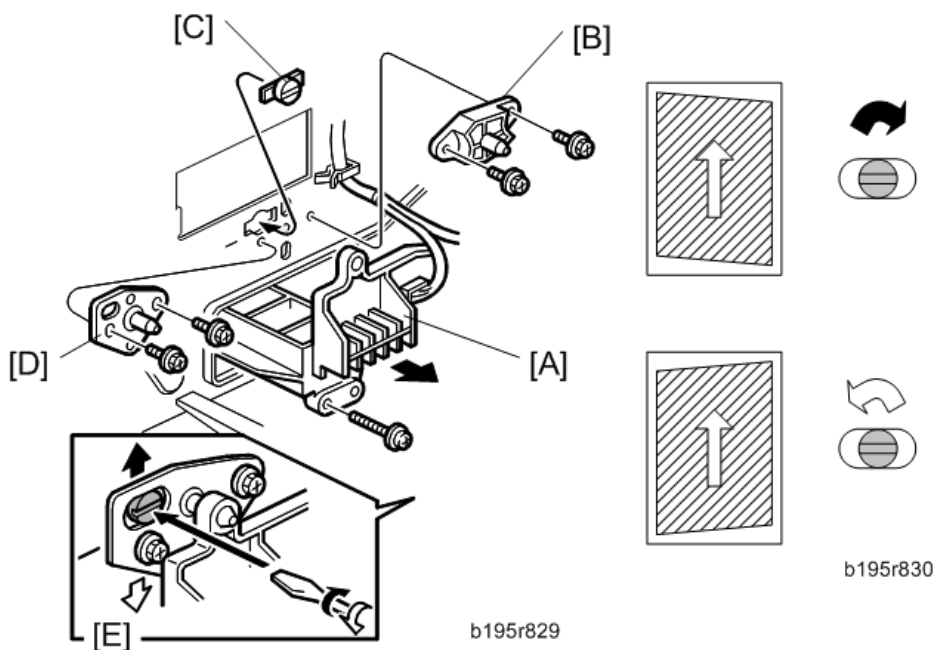

1. Laser unit [A]
2. Bracket [B] (x2)
3. Install adjustment cam [C] (P/N: A2309003).
4. Secure positioning pin [D] (P/N A2309004) with the two screws removed with the bracket [B]. Do not tighten the screws at this time.
5. To adjust the position of the laser unit [E]
  - 1) Adjust the laser unit position by turning the adjustment cam. (See the illustration above.)
  - 2) Tighten the adjustment bracket.
  - 3) Print the trimming area pattern to check the image. If the results are not satisfactory, repeat steps 5-1) to 5-3).

### 4.15.3 TOUCH SCREEN CALIBRATION

Do the following procedure to calibrate the touch screen after you clear the memory, replace the operation panel, LCDC board or NVRAM, or if the touch panel detection function is not working correctly.

**Note**

- Do not attempt to use items [2] to [5], and [7] on the Self Diagnostic Menu. These items are for design use only.

- Turn on the main switch.
- Press the “Simple Screen” key 4 times, the “Suspend” key one time, and then the “Simple Screen” key 4 times to open the Self Diagnostic menu.

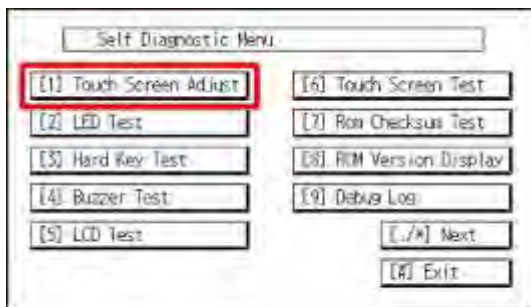

w\_m1322110

- On the touch panel screen, press “[1] Touch Screen Adjust”.



w\_m1322111

- Use a pointed (not sharp!) tool to press the mark + that appears in the upper left, lower right, lower left, center, and upper right in turns on the LCD panel.



w\_m1322115

- Press “[#] OK”.
- Press “[6] Touch Screen Test” on the Self Diagnostic menu.

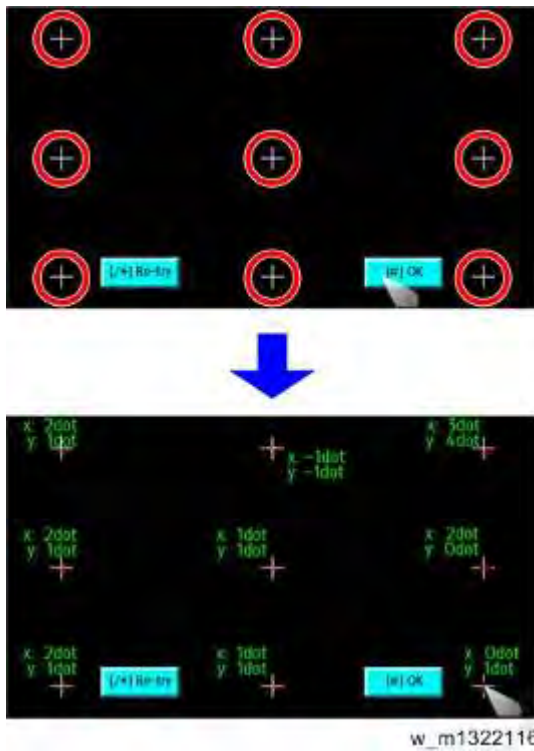

7. Touch the nine points circled in red in the illustration above, and make sure that each point (both x and y) is within +/- 5 dots of the original "+" displayed.



8. When you are finished, press "[#] OK" on the screen.
9. Touch "[#] Exit" on the screen to close the Self Diagnostic menu and save the calibration settings.

Replacement and Adjustment



# SERVICE TABLES

REVISION HISTORY		
Page	Date	Added/Updated/New
1	01/15/2013	Added <i>Entering SP Mode</i> .
72	5/9/2013	SP5749 Import/Export
98	2/25/2014	SP7952
187 ~ 193	5/9/2013	SP5749 Import/Export





## 5. SERVICE TABLES

### 5.1 SERVICE PROGRAM MODE

#### CAUTION

- Make sure that the data-in LED () is not on before you go into the SP mode. This LED indicates that some data is coming to the machine. When the LED is on, wait for the machine to process the data.

#### 5.1.1 SERVICE PROGRAM MODE OPERATION

##### *Service Mode Lock/Unlock*

At locations where the machine contains sensitive data, the customer engineer cannot operate the machine until the Administrator turns the service mode lock off. This function makes sure that work on the machine is always done with the permission of the Administrator.

- If you cannot go into the SP mode, ask the Administrator to log in with the User Tool and then set "Service Mode Lock" to OFF. After he or she logs in:

**[User Tools] > [System Settings] > [Administrator Tools] > [Service Mode Lock] > [OFF]**



- This unlocks the machine and lets you get access to all the SP codes.
  - The service technician can do servicing on the machine and turn the machine off and on. It is not necessary to ask the Administrator to log in again each time the machine is turned on.
- If you must use the printer bit switches, go into the SP mode and set **SP5169** to "1".
  - After machine servicing is completed:
    - Change **SP5169** from "1" to "0".
    - Turn the machine off and on.
    - Tell the administrator that you completed servicing the machine.
    - The administrator will then set the "Service Mode Lock" to ON.

#### ⇒ 5.1.2 ENTERING SP MODES

##### *If The Power is Already On:*

Press the "Home"  and "Simple screen"  keys at the same time for more than 3 seconds, and then press the "User tool"  key.

##### *If The Power is Already Off:*

Press the "Home"  and "Suspend"  keys at the same time while turning the main switch on.

## 5.1.2 SERVICE PROGRAM MODE TABLES

Please note these general changes in this section:

- Group 8 (Data Log 2) is a new group of counters.
- Along with the addition of Group 8, many of the Group 7 counters have been removed.

### ***Service Table Key***

Notation	What it means
[range / <b>default</b> / step]	Example: [-9 to +9 / <b>0</b> / 0.1 mm step]. The setting can be adjusted in the range $\pm 9$ , value reset to +3.0 after an NVRAM reset, and the value can be changed in 0.1 mm steps with each key press.
*	Value stored in NVRAM. After a RAM reset, this default value (factory setting) is restored.
DFU	Denotes "Design or Factory Use". Do not change this value.
Japan only	The feature or item is for Japan only. Do not change this value.
SSP	This denotes a "Special Service Program" mode.

## 5.2 SERVICE PROGRAM MODE TABLES

### 5.2.1 SP TABLES

There are the most commonly used SP codes in the "Service Main SP Tables" and "Engine Main SP Tables - 1 to - 9" of "Main Chapters".

See "Appendices" for the following information:

- Service SP Tables
- Engine SP Tables

## 5.3 SERVICE MAIN SP TABLES

### 5.3.1 SP1-XXX

1001	Bit Switch			
001	Bit Switch 1		0	1
	bit 0	DFU	-	-
	bit 1	DFU	-	-
	bit 2	DFU	-	-
	bit 3	<b>No I/O Timeout</b>	0: Disable	1: Enable
		Enable: The MFP I/O Timeout setting will have no effect. I/O Timeouts will never occur.		
	bit 4	<b>SD Card Save Mode</b>	0: Disable	1: Enable
		Enable: Print jobs will be saved to an SD Card in the GW SD slot.		
	bit 5	DFU	-	-
	bit 6	DFU	-	-
bit 7	<b>[RPCS,PCL]: Printable area frame border</b>	0: Disable	1: Enable	
	Enable: The machine prints all RPCS and PCL jobs with a border on the edges of the printable area.			

1001	Bit Switch			
002	Bit Switch 2		0	1
	bit 0	DFU	-	-
	bit 1	DFU	-	-
	bit 2	<b>Applying a collation Type</b>	Shift Collate	Normal Collate
		<p>A collation type (shift or normal) will be applied to all jobs that do not already have a 'Collate Type' configured.</p> <p><b>Note</b></p> <ul style="list-style-type: none"> <li>If #5-0 is enabled, this Bit Switch has no effect.</li> </ul>		
	bit 3	<b>[PCL5e/c,PS]: PDL Auto Switching</b>	0: Enable	1: Disable
		<p>Disable: The MFPs ability to change the PDL processor mid-job. Some host systems submit jobs that contain both PS and PCL5e/c. If Auto PDL switching is disabled, these jobs will not be printed properly.</p>		
	bit 4	DFU	-	-
	bit 5	DFU	-	-
bit 6	DFU	-	-	
bit 7	DFU	-	-	

Service Tables

1001	Bit Switch			
003	Bit Switch 3		0	1
	bit 0	DFU	-	-
	bit 1	DFU	-	-
	bit 2	<b>[PCL5e/c]: Legacy HP compatibility</b>	0: Disable	1: Enable
		<p>Enable: Uses the same left margin as older HP models such as HP4000/HP8000. In other words, the left margin defined in the job (usually "&lt;ESC&gt;*r0A") will be changed to "&lt;ESC&gt;*r1A"</p>		

Service Main SP Tables

	bit 3	DFU	-	-
	bit 4	DFU	-	-
	bit 5	DFU	-	-
	bit 6	DFU	-	-
	bit 7	DFU	-	-

<b>1001</b>	<b>Bit Switch</b>			
004	Bit Switch 4		0	1
	bit 0	DFU	-	-
	bit 1	DFU	-	-
	bit 2	DFU	-	-
	bit 3	<b>IPDS print-side reversal</b>	0: Disable	1: Enable
	Enable: Increases printing speed but simplex pages may be printed on the back side of the sheet.			
	bit 4	DFU	-	-
	bit 5	DFU	-	-
	bit 6	DFU	-	-
	bit 7	<b>IPDS support tools</b>	0: Disable	1: Enable
	Enable: Enables the port for IPDS support tools.			

1001	Bit Switch		
005	Bit Switch 5	0	1
	bit 0	<b>Show "Collate Type", "Staple Type" and "Punch Type" buttons on the operation panel.</b>	Disable      Enable
		<p>If enabled, users will be able to configure a Collate Type, Staple Type, and Punch Type from the operation panel. The available types will depend on the device and configured options.</p> <p>After enabling the function, the settings will appear under: "User Tools &gt; Printer Features &gt; System"</p>	
	bit 1	<b>Multiple copies if a paper size or type mismatch occurs</b>	0: Disable (Single copy)      1: Enable (Multiple copy)
		<p>If a paper size or type mismatch occurs during the printing of multiple copies, only a single copy is output by default. Using this Bit Switch, the device can be configured to print all copies even if a paper mismatch occurs.</p>	
	bit 2	<b>Prevent SDK applications from altering the contents of a job</b>	0: Disable      1: Enable
		<p>If this switch is enabled, SDK applications will not be able to alter print data. This is achieved by preventing SDK applications from accessing a module called the "GPS Filter".</p> <p>Note: The main purpose of this switch is for troubleshooting the effects of SDK applications on data.</p>	
	bit 3	<b>[PS] PS Criteria</b>	Pattern3      Pattern1
		<p>Change the number of PS criterion used by the PS interpreter to determine whether a job is PS data or not.</p> <p>Pattern3: includes most PS commands.</p> <p>Pattern1: A small number of PS tags and headers</p>	





	bit 4	<b>Increase max number of the stored jobs to 1000 jobs.</b>	Disable (100)	Enable (1000)
		Enable: Changes the maximum number of jobs that can be stored on the HDD via Job Type settings to 1000. The default is 100.		
	bit 5	DFU	-	-
	bit 6	<b>Method for determining the image rotation for the edge to bind on.</b>	0: Disable	1: Enable
		<p>If enabled, the image rotation will be performed as they were in the specifications of older models for the binding of pages of mixed orientation jobs.</p> <p>The old models are below:</p> <ul style="list-style-type: none"> <li>- PCL: Pre-04A models</li> <li>- PS/PDF/RPCS:Pre-05S models</li> </ul>		
	bit 7	<b>Letterhead mode printing</b>	0: Disable	1: Enable (Duplex)
		<p>Routes all pages through the duplex unit.</p> <p>If this is disabled, simplex pages or the last page of an odd-paged duplex job are not routed through the duplex unit. This could result in problems with letterhead/pre-printed pages.</p> <p>Only affects pages specified as Letterhead paper.</p>		

1001	Bit Switch		
006	Bit Switch 6 <b>DFU</b>	-	-

1001	Bit Switch			
007	Bit Switch 7		0	1
	bit 0	<b>Print path</b>	0: Disable	1: Enable
		If enabled, simplex pages (in mixed simplex/duplex PS/PCL5 jobs only) and the last page of an odd paged duplex job (PS, PCL5, PCL6), are always routed through the duplex unit. Not having to switch paper paths increases the print speed slightly.		
	bit 1 to 7	DFU	-	-

1001	Bit Switch			
008	Bit Switch 8 <b>DFU</b>		-	-
	bit 0 to 3	DFU	-	-
	bit 4	<b>PCL edge to edge printing setting</b>	0: Disable (Standard)	1: Enable (BMS)
		Switches the edge to edge printing setting for custom-made machines (BMS).		
	bit 5 to 7	DFU	-	-

Service Tables

1001	Bit Switch			
009	Bit Switch 9	0	1	
	bit 0	<b>PDL Auto Detection timeout of jobs submitted via USB or Parallel Port (IEEE 1284).</b>	"Disabled (Immediately)"	"Enabled (10 seconds)"
		To be used if PDL auto-detection fails. A failure of PDL autodetection doesn't necessarily mean that the job can't be printed. This bit switch tells the device whether to time-out immediately (default) upon failure or to wait 10 seconds.		
	bit 1	DFU	-	-
	bit 2	<b>Job Cancel</b>	Disabled (Not cancelled)	Enabled (Cancelled)
		If this bit switch, all jobs will be cancelled after a jam occurs. Note: If this bitsw is enabled, printing under the following conditions might result in problems: - Job submission via USB or Parallel Port - Spool printing (WIM >Configuration > Device Settings > System)		
	bit 3	<b>PCL/PS bypass tray paper rotation (SEF/LEF)</b>	0: Disable	1: Enable
		This bitsw causes the device to revert to the behavior of previous generations. It only takes effect if "Bypass Tray Setting Priority" = "Driver/Command". Previous spec (bitsw=1): If a standard sized paper mismatch occurred in the bypass tray, the MFP always prompted for SEF paper. If this bitsw=0 (default) then in the event of a standard sized paper mismatch, the MFP will always prompt for paper of the rotation (SEF/LEF) determined by the MFP bypass tray paper setting or by the bypass tray sensor.		
	bit 4	<b>Response to PJI USTATUS when multiple collated copies are printed</b>	0: Disable	1: Enable

		When enabled, if multiple collated copies are printed, the device no longer responds to PJJ USTATUS with the number of pages in the current copy. Instead the device will return the total number of pages for all copies.	
	Bit 5 to 7	DFU	-

1001	Bit Switch		
010	Bit Switch 10		0
	bit 0 to 4	DFU	-
	bit 5	<b>List / Test Print Lock</b>	0: Disable
		If enabled, you can lock or unlock the [List/Test Print] items under the Pinter Features menu when the Store and Skip Errored Job Function is on.	
	Bit 6	<b>Optional charge machines</b>	-
		If enabled, you can use the optional charge machines when the Store and Skip Errored Job Function is on.	0: Disable
	Bit 7	DFU	-



Service Main SP Tables

1001	Bit Switch			
011	Bit Switch 11		0	1
	bit 0	<b>List / Test Print menu</b>	0: Disable	1: Enable
		When enabled, the [Multiple Lists] menu is displayed in [List / Test Print] under the Printer Features menu.		
	bit 1	<b>Interrupt printing</b>	0: Job	1: Page
		Selects the units for the interrupt printing function. When you select "0," you can interrupt printing of a job while being processed. When you select "1," you can interrupt printing of a page while being processed.		
	Bit 2 to 7	DFU	-	-

1001	Bit Switch			
012	Bit Switch 12		0	1
	bit 0 to 7	DFU	-	-

1003	<b>[Clear Setting]</b>			
1003 001	Initialize Printer System			
	Initializes settings in the "System" menu of the user mode.			
1003 003	Delete Program			

1004	<b>[Print Summary]</b>			
1004 001	Print Printer Summary			
	Prints the service summary sheet (a summary of all the controller settings).			

1005	<b>[Display Version]</b>	
1005 002	Printer Version	
	Displays the version of the printer application.	

1007	<b>[Supply Info.]</b>	
1007 001	[0 to 1 / 1 ]	
	0: Displays the info. 1: Does not display the info.	

1110	<b>[Media Print Device Setting]</b>	
1110 002	0: Disable 1: Enable	Selects the setting for the media print device.

1111	<b>[All Job Delete Mode]</b>	
1111 001	0: Excluding New Job 1: Including New Job	Select whether to include an image processing job in jobs subject to full cancellation from the SCS job list.

## 5.4 ENGINE MAIN SP TABLES-1

### 5.4.1 SP1-XXX: FEED

1001*	Leading Edge Registration	
	Adjusts the leading edge registration by changing the registration clutch operation timing.	
001	Tray: Plain	[-9 to 9/ <b>0</b> / 0.1 mm step]
002	Tray: Thick 1	
003	Tray: Thick 2	
004	By-pass: Plain	
005	By-pass: Thick 1	
006	By-pass: Thick 2	
007	Duplex: Plain	
008	Duplex: Thick 1	

1002*	Side-to-Side Registration	
	Adjusts the side to side registration by changing the laser main scan start position for each mode.	
001	By-pass	[-4 to 4/ <b>0</b> / 0.1 mm step]
002	Tray 1	
003	Tray 2	
004	Tray 3	
005	Tray 4	
006	LCT	
007	Duplex	

1003*	Registration Buckle Adjustment	
	Adjusts the paper feed motor timing. Paper feed motor timing determines the amount of paper buckle at Registration. (A "+" setting causes more buckling.)	
001	Tray 1: Plain	[-9 to 5 / -4 / 1 mm step]
002	Tray 1: Thick 1	
003	Tray 1: Thick 2	
004	Tray 2, 3, 4: Plain	
005	Tray 2, 3, 4: Thick1	
006	Tray 2, 3, 4: Thick2	
007	By-pass: Plain	[-9 to 5 / -2 / 1 mm step]
008	By-pass: Thick 1	
009	By-pass: Thick 2	
010	Duplex: Plain	[-9 to 5 / -4 / 1 mm step]
011	Duplex: Thick 1	[-9 to 5 / -3 / 1 mm step]
012	LCT: Plain	[-9 to 5 / -4 / 1 mm step]
013	LCT: Thick1	
014	LCT: Thick2	

Service  
Tables

1007*	By-pass Paper Size Detection	
	Controls paper size detection for the by-pass feed table.	
001	Detection Timing	[-15 to 15 / 0 / 5 mm step]
002	LG Detection	[0 to 1 / 0 / 1] 0: LT SEF, 1: LG



1105*	Fusing Temperature Adjustment	
	<p>Allows adjustment of the hot roller temperature at the center and ends of the roller for the quality or thickness of the paper. The hot roller in this machine has two fusing lamps: one heats the center of the roller, the other heats both ends. Each fusing lamp can be adjusted separately.</p> <p>The "re-load temperature" is the "print ready temperature". When the fusing temperature exceeds this setting, the machine can operate. Do not set up a re-load temperature (Re-load Temp. = Fusing. Temp – SP Value.) that is higher than the SP1-105-2 setting.</p>	
001	Roller Center	[100 to 170 / <b>150</b> / 1 deg]
	Adjusts the fusing temperature at the center of the hot roller.	
002	Roller Ends	[100 to 170 / <b>155</b> / 1 deg]
	Adjusts the fusing temperature at the ends of the hot roller.	
003	Re-load Temp. Minus: Roller Center	[0 to 60 / <b>0</b> / 1 deg]
	<p>Sets the reload temperature for the center of the hot roller. This setting depends on the target temperature.</p> <p>Reload temp. = Target Temp – This SP Setting</p> <p><b>Note</b></p> <ul style="list-style-type: none"> <li>Do not set a temperature that is higher than the setting for SP1105 1 (Roller Center: Trays)</li> </ul>	
004	Re-load Temp. Minus: Roller Ends	[0 to 60 / <b>0</b> / 1 deg]
	<p>Sets the reload temperature for the ends of the hot roller. This setting depends on the target temperature.</p> <p>Reload temp. = Target Temp – This SP Setting</p> <p><b>Note</b></p> <ul style="list-style-type: none"> <li>Do not set a temperature that is higher than the setting for SP1105 2 (Roller Ends: Trays)</li> </ul>	
005 to 022	The following SPs adjust the fusing temperature at the center or ends of the hot roller for each paper type.	
005	Roller Center: M-Thick	[100 to 170 / <b>155</b> / 1 deg]

006	Roller Ends: M-Thick	[100 to 170 / <b>160</b> / 1 deg]
007	Roller Center: Thick 1	[100 to 170 / <b>130</b> / 1 deg]
008	Roller Ends: Thick 1	
009	Roller Center: Thick 2	[100 to 170 / <b>150</b> / 1 deg]
010	Wait Temp: Center Minus	
011	Wait Temp: Ends Minus	[100 to 170 / <b>140</b> / 1 deg]
012	Roller Ends: Thin	[100 to 170 / <b>145</b> / 1 deg]
013	Roller Center: OHP: Plain	[100 to 170 / <b>150</b> / 1 deg]
014	Roller Ends: OHP: Plain	[100 to 170 / <b>155</b> / 1 deg]
015	Roller Center: OHP: Thick	
016	Roller Ends: OHP: Thick	[100 to 170 / <b>160</b> / 1 deg]
017	Roller Center: Special 1	[100 to 170 / <b>150</b> / 1 deg]
018	Roller Ends: Special 1	[100 to 170 / <b>155</b> / 1 deg]
019	Roller Center: Special 2	[100 to 170 / <b>150</b> / 1 deg]
020	Roller Ends: Special 2	[100 to 170 / <b>155</b> / 1 deg]
021	Roller Center: Special 3	[100 to 170 / <b>150</b> / 1 deg]
022	Roller Ends: Special 3	[100 to 170 / <b>155</b> / 1 deg]
023	Feed Waiting: Plain	<p>Turns the feed waiting mode on or off for each paper type.</p> <p>[0 to 1 / <b>0</b> / 1]</p> <p>0=Off, 1=On</p> <p>The paper waits at the registration roller until the fusing temperature reaches the prescribed temperature (adjustable with SP1105-028 to -37).</p> <p>If you enable this feature, also set SP 1105-38 to a convenient value for the customer.</p>
024	Feed Waiting: M-Thick	
025	Feed Waiting: Thick 1	
026	Feed Waiting: Thick 2	
027	Feed Waiting: Thin	

Service  
Tables

Engine Main SP Tables-1

028	Feed Wait: Center Minus: Plain	Adjusts the offset value for each re-load temperature to exit the feed waiting mode. [0 to 60 / 0 / 1 deg]
029	Feed Wait: Ends Minus: Plain	
030	Feed Wait: Center Minus: M-Thick	
031	Feed Wait: Ends Minus: M-Thick	
032	Feed Wait: Center Minus: Thick 1	
033	Feed Wait: Ends Minus: Thick 1	
034	Feed Wait: Center Minus: Thick 2	
035	Feed Wait: Ends Minus: Thick 2	
036	Feed Wait: Center Minus: Thin	
037	Feed Wait: Ends Minus: Thin	
038	Feed Waiting: Maximum Time	Sets the maximum feed waiting time. [0 to 30 / 0 / 1 sec] The paper is fed when the time specified with this SP has passed even though the fusing temperature has not reached the prescribed temperature. 0: Disabled.

1106	Fusing Temperature Display	
001	Roller Center	Displays the temperature of the fusing unit. [-20 to 250 / 0 / 1 deg]
002	Roller Ends	
003	Machine Inside at Power On	Displays the temperature inside the machine. [-20 to 250 / 0 / 1 deg]
004	Machine Inside	

1801*	MotorSpeedAdjust	
	<p>Adjusts the speeds of each motor. Each step decreases or increases motor speed in 0.05% increments</p> <p>Regist: Registration motor, Feed: Feed motor,                  Duplex: Duplex/By-pass motor, Inverter: Duplex inverter motor,                  Exit: Paper exit motor, Bridge: Bridge unit drive motor,                  OpcMot: Drum motor, TransferMot: Transfer/Development Motor,                  FusingMot: Fusing motor,                  DevPuddleMot: Development Paddle motor</p>	
001	Regist: 90: Thick 2	[-2 to 2 / <b>0.4</b> / 0.05 %]
002	Regist: 154: Thick 1	
003	Regist: 180: Plain	
004	Regist: 230: Plain	
005	Feed: 90: Thick 2	[-2 to 2 / <b>-0.4</b> / 0.05 %]
006	Feed: 154: Thick 1	
007	Feed: 180: Plain	[-2 to 2 / <b>-1</b> / 0.05 %]
008	Feed: 230: Plain	
009	Duplex_CW: 90: Thick 2	[-4 to 4 / <b>0.4</b> / 0.1 %]
010	Duplex_CW: 154: Thick 1	
011	Duplex_CW: 180: Plain	[-4 to 4 / <b>-2.3</b> / 0.1 %]
012	Duplex_CW: 230: Plain	
013	Duplex_CCW: 90: Thick 2	[-4 to 4 / <b>0.4</b> / 0.1 %]
014	Duplex_CCW: 154: Thick 1	
015	Duplex_CCW: 180: Plain	[-4 to 4 / <b>-0.2</b> / 0.1 %]
016	Duplex_CCW: 230: Plain	
017	Inverter_CW: 90: Thick 2	[-4 to 4 / <b>0</b> / 0.1 %]
018	Inverter_CW: 154: Thick 1	

Service  
Tables

Engine Main SP Tables-1

019	Inverter_CW: 180: Plain	
020	Inverter_CW: 230: Plain	
021	Inverter_CCW: 90: Thick 2	
022	Inverter_CCW: 154: Thick 1	
023	Inverter_CCW: 180: Plain	
024	Inverter_CCW: 230: Plain	
025	Exit_CW: 90: Thick 2	
026	Exit_CW: 154: Thick 1	
027	Exit_CW: 180: Plain	
028	Exit_CW: 230: Plain	
029	Bridge: 90: Thick 2	
030	Bridge: 154: Thick 1	
031	Bridge: 180: Plain	
032	Bridge: 230: Plain	
033	OpcMot:90	[-4 to 4 / <b>0</b> / 0.01 %]
034	OpcMot:154	
035	OpcMot:180	
036	OpcMot:230	
037	TransferMot:90	
038	TransferMot:154	
039	TransferMot:180	
040	TransferMot:230	
041	FusingMot:90	
042	FusingMot:154	
043	FusingMot:180	

044	FusingMot:230	
045	DevPuddleMot	[-4 to 4 / <b>0</b> / 0.1 %]

1902*	Cleaning Web Setting	
001	Web Consumption	[0 to 120 / <b>0</b> / 1 %]
	Displays the consumed amount of the web roll.	
002	Web Motor Interval	[3 to 130 / <b>6.7</b> / 0.1 sec]
	Adjusts the interval for web motor rotation.	
003	Web Motor Time	[0.3 to 10 / <b>4.2</b> / 0.1 sec]
	Adjusts the rotation time of the web motor.	
004	Web Near End Setting	EU [0 to 100 / <b>90</b> / 1 %] ASIA/NA [0 to 100 / <b>92</b> / 1 %]
	Adjusts the threshold for web near end.	
005	Web Motor Interval: Thick 1	[3 to 130 / <b>11.2</b> / 0.1 sec]
	Adjusts the interval for web motor rotation (thick 1).	
006	Web Motor Interval: Thick 2	[3 to 130 / <b>16.8</b> / 0.1 sec]
	Adjusts the interval for web motor rotation (thick 2).	
007	Paper Interval Time	[0 to 10 / <b>5</b> / 1 sec]
	Adjusts the threshold for paper feeding. When the time between trailing edge detection and leading edge detection is within the value of this setting, the machine determines that the paper is still being fed.	
008	Web Motor Setting: Web End	[0 to 60 / <b>27</b> / 1 sec]
	Adjusts the motor rotation time after the web end.	
009	Web Motor Rotation: Power On	[0 to 10 / <b>0</b> / 1 times]
	Adjusts the number of web motor rotations at the re-load state.	

Service  
Tables

Engine Main SP Tables-1

010	Web Motor Interval: Pre-idle	[0 to 30 / <b>0</b> / 1 sec]
	Adjusts the motor waiting time after the fusing motor idling.	
011	Web Motor Rotation: Pre-idle	[0 to 10 / <b>0</b> / 1 times]
	Adjusts the number of web motor rotations at the fusing idling state.	

1950*	Tray Lock at Jam	[0 or 1 / <b>0</b> / 1 ] 0= OFF, 1= ON
	<b>Not used</b>	

## 5.5 ENGINE MAIN SP TABLES-2

### 5.5.1 SP2-XXX: DRUM

2005*	Bias Control	
001	Bias Correction 1	[0.1 to 1 / <b>0.85</b> / 0.05 step]
	Adjusts the lower threshold value for the charge roller correction. When the value of VSDP/VSG is greater than this value, the charge roller voltage increases by 30 V (e.g., from -500 to -530).	
002	Bias Correction 2	[0.1 to 1 / <b>0.9</b> / 0.05 step]
	Adjusts the upper threshold value for the charge roller correction. When the value of VSDP/VSG is greater than this value, the charge roller voltage decreases by 30 V (absolute value).	
003	Bias Adjustment 1	[1000 to 2000 / <b>1500</b> / 10 vol]
	Adjusts the lower limit value for charge roller voltage correction.	
004	Bias Adjustment 2	[1000 to 2000 / <b>2000</b> / 10 vol]
	Adjusts the upper limit value for charge roller voltage correction.	
005	Bias Adjustment 3	[0 to 100 / <b>30</b> / 10 vol]
	Adjusts the correction voltage adjustment step size.	

2103*	Erase Margin Adjustment	
	Adjusts the erase margin by deleting image data at the margins. L Size: 297.1 mm or more (length) M Size: 216.1 to 297 mm (length) S Size: 216 mm or less (length)	
001	Leading Edge	[0 to 9 / <b>3</b> / 0.1mm]
002	Trailing Edge	
003	Left	[0 to 9 / <b>2</b> / 0.1mm]

Service Tables



Engine Main SP Tables-2

004	Right	
005	Duplex Trail.: L Size: Plain	[0 to 4 / <b>1</b> / 0.1mm]
006	Duplex Trail.: M Size: Plain	[0 to 4 / <b>0.8</b> / 0.1mm]
007	Duplex Trail.: S Size: Plain	[0 to 4 / <b>0.6</b> / 0.1mm]
008	Duplex Left: Plain	[0 to 1.5 / <b>0.3</b> / 0.1mm]
009	Duplex Right: Plain	
010	Duplex Trail.: L Size: Thick	[0 to 4 / <b>0.8</b> / 0.1mm]
011	Duplex Trail.: M Size: Thick	[0 to 4 / <b>0.6</b> / 0.1mm]
012	Duplex Trail.: S Size: Thick	[0 to 4 / <b>0.4</b> / 0.1mm]
013	Duplex Left: Thick	[0 to 1.5 / <b>0.1</b> / 0.1mm]
014	Duplex Right: Thick	

2105*	LD Power (DFU)	
	Adjusts the LD power for each mode. Each LD power setting is decided by the process control.	
001	Process control	[-50 to 79 / <b>35</b> / 1 ]
002	Process control	
003	Print	[-50 to 79 / <b>5</b> / 1 ]
004	Print	

2109	Test Pattern	
001	Pattern Selection	[0 to 24 / <b>0</b> / 1 ] Test pattern of the GAVD
	0: None 1: Vertical Line (1 dot) 2: Vertical Line (2 dot) 3: Horizontal Line (1 dot) 4: Horizontal Line (2 dot) 5: Grid Vertical Line 6: Grid Horizontal Line 7: Grid pattern small 8: Grid Pattern Large 9: Argyle Pattern Small 10: Argyle Pattern Large 11: Independent pattern (1 dot) 12: Independent Pattern (2 dot)	13: Independent Pattern (4 dot) 14: Trimming Area 15: Hound's Tooth Check (Vertical) 16: Hound's Tooth Check (Horizontal) 17: Black Band (Horizontal) 18: Black band ( Vertical) 19: Checker Flag Pattern 20: Grayscale (Vertical Margin) 21: Grayscale (Horizontal Margin) 22: Two Beam Density Pattern 23: Full Dot Pattern 24: All white Pattern
002	Density	[0 to 15 / <b>15</b> / 1 ] Set the density of the test pattern which is output in SP2109-001. This SP is not used for the Grayscale patterns.



2220*	Vref Setting
	Adjusts the TD sensor reference voltage (Vref). Change this value after replacing the development unit with another development unit that contains toner. [1 to 5 / <b>4</b> / 0.01 ] 1. Check the value of SP2-220 in both the machine containing the test unit and the machine that you are going to move it to. 2. Install the test development unit, and then input the VREF for this unit into SP2-220. 3. After the test, put back the old development unit, and change SP2-220 back to the original value.

2221*	Reverse Interval Drum, Transfer	[0 to 2000 / 0 / 1 sheets]
	Adjusts the threshold for the reverse rotation of the drum and development/transfer motors. This helps the drum and transfer belt cleaning operations. This reverse rotation will interrupt a multiple printing job.	

2801*	TD Sensor Initial Setting	Initialization
	<p>Performs the TD sensor initial setting and allows the service technician to enter the lot number of the developer. (The lot number is embossed on the edge of the developer package.) This SP mode controls the voltage applied to the TD sensor to make the TD sensor output about 3.0 V. Press "Execute" to start. After finishing this, the TD sensor output voltage is displayed.</p> <p>Use this mode only after installing the machine, changing the TD sensor, or adding new developer.</p>	

2960*	Toner Overflow Sensor	[0 = OFF, 1= ON]
	Selects whether or not the toner overflow sensor is activated.	

2972*	Grayscale Limit ( <b>SSP</b> )	
	Controls the halftone density level to prevent deterioration of the OPC. The halftone density is detected by the ID sensor, and the machine adjusts the intensity of the LD beam according to the upper/lower limit setting.	
001	Upper Limit	[0 to 100 / 63 / 1vol ]
	<p>Defines the upper limit for grayscale.</p> <p>A larger value allows a wider range of halftones at the pale end of the scale. If the image contains pale areas with fuzzy borders surrounded by dark areas, reduce this value to make the borders clearer.</p>	
002	Lower Limit	[0 to 100 / 57 / 1vol ]
	<p>Defines the lower limit for grayscale.</p> <p>A smaller value allows a wider range of halftones at the dark end of the scale.</p>	

2973*	Grayscale Cycle ( <b>SSP</b> )	[0 to 1000 / <b>100</b> / 10 sheets ]
	Set s the halftone operation interval in order to prevent deterioration of the OPC. If the number of copies exceeds this setting, at the end of the job, or if the door is opened and closed, charge correction is executed.	

2974*	Image Density	
001	Adjustment Mode	[1 to 5 / <b>3</b> / 1 ]
	Adjusts image density. Changing this setting adjusts development bias and ID sensor output voltage that in turn raises or lowers image density.	

2980*	Charge Counter	[0 to 1000000 / <b>0</b> / 1 sheets ]
	<p>Set the number of pages to print after toner and carrier initialization before the charge input is increased to compensate for deterioration over time in the polarity of the carrier.</p> <p>The strength in the polarity of the carrier in the toner will eventually decrease and cause lower charge output. Setting the charge output to increase after a specified number of copies can compensate for this effect.</p>	

## 5.6 ENGINE MAIN SP TABLES-3

### 5.6.1 SP3-XXX: PROCESS

3001	P Sensor Setting	
	Current	[0 to 43 / <b>13</b> / 0.1 mA ]
001*	Allows you to reset the PWM of the ID sensor LED to avoid a service call error after clearing NVRAM or replacing the NVRAM. The PWM data is stored by executing SP-3001-2.	
	Initialization	-
002	Performs the ID sensor initial setting. ID sensor output for the bare drum (VSG) is adjusted automatically to 4.0 ±0.2 V. Press "Execute" to start. Perform this setting after replacing or cleaning the ID sensor, replacing the drum, or clearing NVRAM.	

3045*	Toner End Setting <b>DFU</b>	
001	ON/OFF	[0 to 1 / <b>0</b> / 1] 0=Off, 1=On

3902*	New PCU Detection ( <b>Not used</b> )	
	ON/OFF Setting	[0 to 1 / <b>0</b> / 1] 0: On, 1: Off
001	Turns on or off the new unit detection for the transfer belt unit and fusing unit.	

## 5.7 ENGINE MAIN SP TABLES-4

There are no Group 4 SP modes for this machine.



## 5.8 ENGINE MAIN SP TABLES-5

### 5.8.1 SP5-XXX: MODE

5009*	Add Display Language	Bit SW		
201,202,203,204	Adds language available in user choice. (Only the languages registered in the machine) The available languages are shown below.			
	<b>List Num.</b>	<b>language</b>	<b>List Num.</b>	<b>language</b>
	1	Japanese	15	Czech
	3	US English	16	Finnish
	4	French	17	Traditional Chinese
	5	German	18	Simplified Chinese
	6	Italian	19	Thai
	7	Spanish	20	Russian
	8	Dutch	22	Hebrew
	9	Norwegian	23	Greek
	10	Danish	24	Korean
	11	Swedish	25	Catalan
	12	Polish	26	Turkish
	13	Portuguese	27	Brazilian Portuguese
	14	Hungarian		
	Check the list number of the language to add from the list above. And then change the bit switch settings of the SP5009-201, -202, -203, or -204 refer to the table below.			

	List Num.	Assigned Bit Switch
	No.1~8	BIT1 to 8 (SP5009-201)
	No.9~16	BIT1 to 8 (SP5009-202)
	No.17~24	BIT1 to 8 (SP5009-203)
	No.25~32	BIT1 to 8 (SP5009-204)
<p>Example: To add US English (No.3 in the list) or Czech (No.15)                      Turn Bit 3 of "SP5009-201" 0 to 1 for US English.                      Turn Bit 7 of "SP5009-202" 0 to 1 for Czech.                      After setting, turn the main power switch off and on to make the setting valid.</p>		

5024*	mm/inch Display Selection	0: Europe/Asia (mm) 1: North America (inch)
	Selects the unit of measurement. After selection, turn the main power switch off and on.	

5047*	Paper Display
	Turns on or off the printed paper display on the LCD. [0 to 1 / 0 / 1] 0: Not displayed, 1: Displayed

5055*	Display IP Address
	Display or does not display the IP address on the LCD. [0 to 1 / 0 / 1] 0: OFF, 1: ON

5061*	Toner Remaining Icon Display Change
	Display or does not display the remaining toner display icon on the LCD. [0 to 1 / 0 / 1] 0: Not display, 1: Display

Service Tables



5083*	LED ON-OFF setting at Toner Near End
001	Turns LED yellow lighting ON and OFF at Toner Near End. [0 to 1 / 0 / 1 ] 0: OFF, 1: ON

5104*	A3/DLT Double Count ( <b>SSP</b> )
	Specifies whether the counter is doubled for A3/DLT. "Yes" counts except from the bypass tray. When "Yes" is selected, A3 and DLT paper are counted twice, that is A4 x2 and LT x2 respectively.

5112*	Non-Std. Paper Sel.
	Non-Standard Paper Selection [0 to 1 / 1 / 1] 0: Not used, 1: Used

	Paper Size Type Selection
5131*	Selects the paper size (type) for both originals and copy paper. [0 to 2 / - / 1 step] 0: Japan, 1: North America, 2: Europe After changing the setting, turn the copier off and on. If the paper size of the archive files stored on the HDD is different, abnormal copies could result.

	Bypass Length Setting
5150	Sets up the by-pass tray for long paper. [0 to 1 / 0 / 1] 0: Off [Default] 1: On. Sets the tray for feeding paper up to 600 mm long. With this SP selected on, paper jams are not detected in the paper path.

5181*	Paper Size Setting	
	Adjusts the paper size for each tray. [0 to 1 / - / 1]	
001	Tray 1: 1	0: A4 LEF, 1: LT LEF
002	Tray 1: 2	0: A3, 1: DLT
003	Tray 1: 3	0: B4, 1: LG
004	Tray 1: 4	0: B5 LEF, 1: Exe LEF
005	Tray 2: 1	0: A4 LEF, 1: LT LEF
006	Tray 2: 2	0: A3, 1: DLT
007	Tray 2: 3	0: B4, 1: LG
008	Tray 2: 4	0: B5 LEF, 1: Exe LEF
009	Tray 3: 1 (Tandem)	0: A4 LEF, 1: LT LEF
010	Tray 3: 2	0: A3, 1: DLT
011	Tray 3: 3	0: B4, 1: LG
012	Tray 3: 4	0: B5 LEF, 1: Exe LEF
013	Tray 4: 1	0: A4 LEF, 1: LT LEF
014	Tray 4: 2	0: A3, 1: DLT
015	Tray 4: 3	0: B4, 1: LG
016	Tray 4: 4	0: B5 LEF, 1: Exe LEF
017	LCT	[0 to 2 / - / 1] 0: A4 LEF, 1: LT LEF, 2: B5 LEF



5186	RK4: Setting <b>(Japan only)</b>
	<p>Enable or distance the prevention for RK4 (Accounting device) Disconnection. If the RK4 is disconnected for 10 seconds when this SP is set to "1 (Enable)", the machine automatically jams a sheet of paper and stops.</p> <p>[0 to 1 / <b>0</b> / 1]</p>

5199	Paper Exit After Staple End
	<p>This SP determines whether the machine can output paper if staples run out.</p> <p>[0 to 1 / <b>0</b> / 1]</p> <p>0: OFF. Paper cannot exit if no staples are available. 1: ON. Paper can exit with no staples.</p>

5302*	Set Time
002	Time Difference
	<p>Sets the time clock for the local time. This setting is done at the factory before delivery. The setting is GMT expressed in minutes.</p> <p>[-1440 to 1440 / - / 1 min.]</p> <p>Japan: +540 (Tokyo) NA: -300 (NY) EU: +60 (Paris) CH: +480 (Peking) TW: +480 (Taipei) AS: +480 (Hong Kong) KO: +540 (Korea)</p>

5307	Summer Time	
001	Setting	[0 to 1 / 1 (NA/EU), 0 (ASIA) / 1 /step] 0: Disabled 1: Enabled
	<p>Enables or disables the summer time mode.</p> <p><b>Note</b></p> <ul style="list-style-type: none"> <li>Make sure that both SP5-307-3 and -4 are correctly set. Otherwise, this SP is not activated even if this SP is set to "1".</li> </ul>	
003	Rule Set (Start)	
	<p>Specifies the start setting for the summer time mode.</p> <p>There are 8 digits in this SP. For months 1 to 9, the "0" cannot be input in the first digit, so the eight-digit setting for -2 or -3 becomes a seven-digit setting.</p> <p>1st and 2nd digits: The month. [1 to 12] 3rd digit: The week of the month. [1 to 5] 4th digit: The day of the week. [0 to 6 = Sunday to Saturday] 5th and 6th digits: The hour. [00 to 23] 7th digit: The length of the advanced time. [0 to 9 / 1 hour /step] 8th digit: The length of the advanced time. [0 to 5 / 10 minutes /step]</p> <p>For example: 3500010</p> <p>The timer is advanced by 1 hour at am 0:00 on the 5th Sunday in March.</p> <p>The digits are counted from the left.</p> <p>Make sure that SP5-307-1 is set to "1".</p>	
004	Rule Set (End)	
	<p>Specifies the end setting for the summer time mode.</p> <p>There are 8 digits in this SP.</p> <p>1st and 2nd digits: The month. [1 to 12] 3rd digit: The week of the month. [0 to 5] 4th digit: The day of the week. [0 to 7 = Sunday to Saturday] 5th and 6th digits: The hour. [00 to 23]</p> <p>The 7th and 8 digits must be set to "00".</p> <p>The digits are counted from the left.</p> <p>Make sure that SP5-307-1 is set to "1".</p>	



Engine Main SP Tables-5

5404	User Code Count Clear	
	Clears the counts of the user codes assigned by the key operator to restrict the use of the machine. Press [Execute] to clear.	

5413	Lockout Setting	
001	Lockout On/Off	[0 to 1 / <b>0</b> / 1] 0: OFF, 1:ON
	Turns on or off the account lock for the local address book account.	
002	Lockout Threshold	[1 to 10 / <b>5</b> / 1]
	Sets the maximum trial times for accessing the address book account.	
003	Cancellation On/Off	[0 to 1 / <b>0</b> / 1] 0: OFF (Lockout is not cancelled.) 1: ON (Lockout is cancelled if a user ID and password are correctly entered after the lockout function has been executed and a specific time has passed.)
	Turns on or off the cancellation function of the account lockout.	
004	Cancellation Time	[1 to 9999 / <b>60</b> / 1 min]
	Sets the interval of the retry for accessing the local address book account after the lockout function has been executed. This setting is enabled only if SP5413-3 is set to "1" (ON).	

5414	Access Mitigation	
001	Mitigation On/Off	
	Permits or does not permit consecutive access to the machine with the same ID and password. [0 to 1 / <b>0</b> / 1] 0: OFF (Permitted) 1: ON (Not permitted)	
002	Mitigation Time	
	Sets the prohibiting time for consecutive access to the machine with the same ID and password. [0 to 60 / <b>15</b> / 1 min]	

5415*	Password Attack	
001	Permissible Number	[0 to 100 / <b>30</b> / 1 times]
	Sets the threshold number of attempts to attack the system with random passwords to gain illegal access to the system.	
002	Detect Time	[1 to 10 / <b>5</b> / 1 sec]
	Sets a detection time to count a password attack.	

5416*	Access Information	
001	Access User Max Num	[50 to 200 / <b>200</b> / 1 ]
	Sets the number of users for the access exclusion and password attack detection function.	
002	Access Password Num	[50 to 200 / <b>200</b> / 1 ]
	Sets the number of passwords for the access exclusion and password attack detection function.	
003	Monitor interval	[1 to 10 / <b>3</b> / 1 sec]
	Sets the interval of watching out for user information and passwords.	

5417	Access Attack	
001	Access Permissible number	[0 to 500 / <b>100</b> / 1]
	Sets a limit on access attempts to prevent password cracking.	
002	Access Detect Time	[10 to 30 / <b>10</b> / 1 sec]
	Sets a detection time to count password cracking.	
003	Productivity Fall Waite	[0 to 9 / <b>3</b> / 1 sec]
	Sets the wait time to slow down the speed of certification when an excessive number of access attempts have been detected.	
004	Attack Max Num	[50 to 200 / <b>200</b> / 1]
	Sets a limit on the number of requests received for certification in order to slow down the certification speed when an excessive number of access attempts have been detected.	

5420*	User Authentication	
	<p>These settings should be done with the System Administrator.</p> <p> <b>Note</b></p> <ul style="list-style-type: none"> <li>These functions are enabled only after the user access feature has been enabled.</li> </ul>	
041	Printer	[0 or 1/ <b>0</b> / 1] 0: ON. 1: OFF Determines whether certification is required before a user can use the printer application.
051	SDK1	[0 or 1/ <b>0</b> / 1] 0: ON. 1: OFF Determines whether certification is required before a user can use the SDK application.
061	SDK2	
071	SDK3	

5481	Authentication Error Code	
	These SP codes determine how the authentication failures are displayed.	
001	System Log Disp	<p>[0 or 1 / 0 / -]                      0: OFF [Default], 1: ON                      Determines whether an error code appears in the system log after a user authentication failure occurs.</p>
002	Panel Disp	<p>[0 or 1 / 1 / 1]                      0: OFF, 1: ON [Default]                      Determines whether an error code appears on the operation panel after a user authentication failure occurs.</p>

5501*	PM Alarm	
001	PM Alarm Level	
	<p>Sets the PM alarm level.                      [0 to 9999 / 0 / 1 k copies/step]                      0: No PM alarm</p>	
002	Original Count Alarm (DFU)	
	<p>Selects whether the PM alarm for the number of scans is enabled or not.                      If this is "1", the PM alarm function is enabled.                      [0 = No / 1 = Yes]</p>	





5504*	Jam Alarm
	<p>Sets the alarm to sound for the specified jam level (document misfeeds are not included).</p> <p>[0 to 3 / <b>3</b> / 1 step]</p> <p>0: Zero (Off)</p> <p>1: Low (2.5K jams)</p> <p>2: Medium (3K jams)</p> <p>3: High (6K jams)</p>

5505*	Error Alarm
	<p>Sets the number of sheets to clear the error alarm counter.</p> <p>The error alarm counter counts "1" when any SC is detected. However, the error alarm counter decreases by "1" when an SC is not detected during a set number of copied sheets (for example, default 5000 (C1b) or 10000 (C1c) sheets). The error alarm occurs when the SC error alarm counter reaches "5".</p> <p>[0 to 255 / <b>60</b> / 100 copies / step]</p>

5508	CC Call	
001	Jam Remains	<p>Enables/disables initiating a call.</p> <p>[0 to 1 / <b>1</b> / 1]</p> <p>0: Disable</p> <p>1: Enable</p>
002	Continuous Jams	
003	Continuous Door Open	
011	Jam Detection: Time Length	<p>Sets the length of time to determine the length of an unattended paper jam.</p> <p>[3 to 30 / <b>10</b> / 1 minute]</p>
012	Jam Detection Continuous Count	<p>Sets the number of continuous paper jams required to initiate a call.</p> <p>[2 to 10 / <b>5</b> / 1 time]</p>
013	Door Open: Time Length	<p>Sets the length of time the remains opens to determine when to initiate a call.</p> <p>[3 to 30/ <b>10</b> / 1 minute]</p>

5515*	SC/Alarm Setting	
	With @Remote in use, these SP codes can be set to issue an SC call when an SC error occurs. If this SP is switched off, the SC call is not issued when an SC error occurs.	
001	SC Call	[0 or 1 / 1 / 1] 0: OFF 1: ON
002	Service Parts Near End Call	
003	Service Parts End Call	
004	User Call	
006	Communication Information Test Call	
007	Machine Information Notice	
008	Alarm Notice	
010	Supply Automatic Ordering Call	
011	Supply Management Report Call	
012	Jam/Door Open Call	

5516	Individual PM Part Alarm Call	
	With @Remote in use, these SP codes can be set to issue an PM alarm call when one of SP parts reaches its yield.	
001	Disable/Enable Setting (0: Not send, 1: Send)	[0 or 1 / 1 / -] 0: Not send, 1: Send
004	Percent yield for triggering PM alert	[1 to 255 / 75 / 1 %/step]

5731	Counter Effect <b>(Not used)</b>	
001	Change Mk1 Cnt(Paper->Combine)	[0 or 1 / 0 / -] 0:Disable, 1: Enable

Service Tables

5746	<b>BMLinkS (Japan only)</b>	
001	available	Disables or enables the BMLinkS feature. [0 or 1 / <b>1</b> / - ] 0:Disable, 1: Enable
002	interval:mon	Displays the polling interval when the BMLinsS monitor service monitors the machine status. [10 to 3600 / <b>60</b> / 1 sec./step]
004	available:log	Displays the sending feature status of the BMLinkS log service. [0 or 1 / <b>1</b> / - ] 0:Disable, 1: Enable

5749	Import/Export	
	Touch "Execute" to export or import the selected preference information.	
001	Export	Target: [System] [Printer] [Fax] [Scanner] Option: [Unique] [Secret] Crypt config: [Encryption] [Execute]
101	Import	Option: [Unique] Crypt config: [Encryption] Encryption key (if selected) [Execute]

5750	Job Access Log			
	Changes the capacity of log storage.			
	<b>SP7-750-001</b>	<b>Job Log</b>	<b>Access Log</b>	<b>Eco Log</b>
	0:OFF (Default)	2000	6000	2000
	1:ON	8000	1000	1000

5801	Memory Clear	
	Resets NVRAM data to the default settings. Before executing any of these SP codes, print an SMC Report.	
001	All Clear	Initializes items 2 to 19 below.
002	Engine	Initializes all registration settings for the engine and copy process settings.
003	SCS	Initializes default system settings, SCS (System Control Service) settings, operation display coordinates, and ROM update information.
004	IMH Memory Clr	Initializes the image file system. (IMH: Image Memory Handler)
005	MCS	Initializes the automatic delete time setting for stored documents. (MCS: Memory Control Service)
008	Printer Application	Initializes the printer defaults, programs registered, the printer SP bit switches, and the printer CSS counter.
010	Web Service	Deletes the Netfile (NFA) management files and thumbnails, and initializes the Job login ID. Netfiles: Jobs to be printed from the document server using a PC and the DeskTopBinder software

Service Tables

Engine Main SP Tables-5

011	NCS	Initializes the system defaults and interface settings (IP addresses also), the SmartDeviceMonitor for Admin settings, WebStatusMonitor settings, and the TELNET settings. (NCS: Network Control Service)
014	Clear DCS Setting	Initializes the DCS (Delivery Control Service) settings.
015	Clear UCS Setting	Initializes the UCS (User Information Control Service) settings.
016	MIRS Setting	Initializes the MIRS (Machine Information Report Service) settings.
017	CCS	Initializes the CCS (Certification and Charge-control Service) settings.
018	SRM Memory Clr	Initializes the SRM (System Resource Manager) settings.
019	LCS	Initializes the LCS (Log Count Service) settings.
021	ECS	Initializes ECS (Engine Control Service).
025	websys	Initializes websys (Web System).

5802*	FreeRun	
	<p>Performs a free run on the copier engine.</p> <p>The correct paper should be loaded in the 1st tray or 2nd tray, but paper is not fed.</p> <p>The main switch has to be turned off and on after using the free run mode for a test.</p>	
001	TRAY1:A4LEF	-
002	TRAY2:A3	-
003	TRAY2:A4SEF	-

5803	Input Check	
	Displays the signals received from sensors and switches. (☛ p.5-127 "Input Check Table")	

5804	Output Check	
	Turns on the electrical components individually for test purposes. (☛ p.5-137 "Output Check Table")	

5805	Anti-Condensation Heater	
	[0 or 1 / 0 / -] 0:OFF / 1:ON	

5810	SC Reset	
001	Fusing SC Reset	Resets all level A service call conditions, such as fusing errors. To clear the service call, touch "Execute" on the LCD, then turn the main power switch off/on.

5811	MachineSerial	
002	Display	Displays the machine serial number.
004	BCU	Inputs the serial number.

5812*	Service Tel. No. Setting	
001	Service	Inputs the telephone number of the CE (displayed when a service call condition occurs.)
002	Facsimile	Use this to input the fax number of the CE printed on the Counter Report (UP mode).
003	Supply	Inputs the telephone number of the supplier displayed on the user mode screen.

Service Tables

Engine Main SP Tables-5

004	Operation	Allows the service center contact telephone number to be displayed on the user mode screen.
101	Displnquiry	Allows the inquiry display to be displayed on the user mode screen. 0: Displayed 1: Not displayed

5816	Remote Service	
001	I/F Setting	
	Selects the remote service setting. [0 to 2 / <b>2</b> / 1 /step] 0: Remote service off 1: CSS remote service on 2: @Remote service on	
002	CE Call	
	Performs the CE Call at the start or end of the service. [0 or 1 / <b>1</b> / 1 /step] 0: Start of the service 1: End of the service <b>NOTE:</b> This SP is activated only when SP 5816-001 is set to "2".	
003	Function Flag	
	Enables or disables the remote service function. [0 to 1 / <b>0</b> / 1 /step] 0: Disabled, 1: Enabled <b>NOTE:</b> This SP setting is changed to "1" after @Remote registration has been completed.	
007	SSL Disable	
	Uses or does not use the RCG certification by SSL when calling the RCG. [0 to 1 / <b>0</b> / 1 /step] 0: Uses the RCG certification 1: Does no use the RCG certification	

008	RCG Connect Timeout
	Specifies the connect timeout interval when calling the RCG. [1 to 90 / <b>30</b> / 1 second /step]
009	RCG Write Timeout
	Specifies the write timeout interval when calling the RCG. [0 to 100 / <b>60</b> / 1 second /step]
010	RCG Read Timeout
	Specifies the read timeout interval when calling the RCG. [0 to 100 / <b>60</b> / 1 second /step]
011	Port 80 Enable
	Enables/disables access via port 80 to the SOAP method. [0 or 1 / <b>0</b> / –] 0: Disabled, 1: Enabled
013	RFU (Remote Firmware Update) Timing
	Selects the RFU timing. [0 or 1 / <b>1</b> / –] 0: RFU is executed whenever update request is received. 1: RFU is executed only when the machine is in the sleep mode.
014	RCG Error Cause
	[0 or 1 / <b>0</b> / –] 0: Normal 1: Fails to reflect the client/server certificate settings by network failure to reboot. Transitions to 0 on restarting the machine.
021	RCG-C Registered
	This SP displays the Embedded RC Gate installation end flag. 0: Installation not completed 1: Installation completed



023	<p>Connect Type (N/M)</p> <p>This SP displays and selects the Embedded RC Gate connection method.                  [0 or 1 / 0 / 1 /step                  0: Internet connection                  1: Dial-up connection</p>
061	<p>Cert. Expire Timing <b>DFU</b></p> <p>Proximity of the expiration of the certification.</p>
062	<p>Use Proxy</p> <p>This SP setting determines if the proxy server is used when the machine communicates with the service center.</p>
063	<p>Proxy Host</p> <p>This SP sets the address of the proxy server used for communication between Embedded RC Gate-N and the gateway. Use this SP to set up or display the customer proxy server address. The address is necessary to set up Embedded RC Gate-N.</p> <p><b>Note</b></p> <ul style="list-style-type: none"> <li>▪ The address display is limited to 128 characters. Characters beyond the 128 character are ignored.</li> <li>▪ This address is customer information and is not printed in the SMC report.</li> </ul>
064	<p>Proxy Port Number</p> <p>This SP sets the port number of the proxy server used for communication between Embedded RC Gate-N and the gateway. This setting is necessary to set up Embedded RC Gate-N.</p> <p><b>Note</b></p> <ul style="list-style-type: none"> <li>▪ This port number is customer information and is not printed in the SMC report.</li> </ul>

065	Proxy User Name	
	<p>This SP sets the HTTP proxy certification user name.</p> <p><b>Note</b></p> <ul style="list-style-type: none"> <li>The length of the name is limited to 31 characters. Any character beyond the 31st character is ignored.</li> <li>This name is customer information and is not printed in the SMC report.</li> </ul>	
066	Proxy Password	
	<p>This SP sets the HTTP proxy certification password.</p> <p><b>Note</b></p> <ul style="list-style-type: none"> <li>The length of the password is limited to 31 characters. Any character beyond the 31st character is ignored.</li> <li>This name is customer information and is not printed in the SMC report.</li> </ul>	
067	CERT: Up State	
	Displays the status of the certification update.	
	0	The certification used by Embedded RC Gate is set correctly.
	1	The certification request (setAuthKey) for update has been received from the GW URL and certification is presently being updated.
	2	The certification update is completed and the GW URL is being notified of the successful update.
	3	The certification update failed, and the GW URL is being notified of the failed update.
	4	The period of the certification has expired and new request for an update is being sent to the GW URL.
	11	A rescue update for certification has been issued and a rescue certification setting is in progress for the rescue GW connection.
12	The rescue certification setting is completed and the GW URL is being notified of the certification update request.	

Service Tables

	13	The notification of the request for certification update has completed successfully, and the system is waiting for the certification update request from the rescue GW URL.
	14	The notification of the certification request has been received from the rescue GW controller, and the certification is being stored.
	15	The certification has been stored, and the GW URL is being notified of the successful completion of this event.
	16	The storing of the certification has failed, and the GW URL is being notified of the failure of this event.
	17	The certification update request has been received from the GW URL, the GW URL was notified of the results of the update after it was completed, but a certification error has been received, and the rescue certification is being recorded.
	18	The rescue certification of No. 17 has been recorded, and the GW URL is being notified of the failure of the certification update.
068	CERT: Error	
	Displays a number code that describes the reason for the request for update of the certification.	
	0	Normal. There is no request for certification update in progress.
	1	Request for certification update in progress. The current certification has expired.
	2	An SSL error notification has been issued. Issued after the certification has expired.
	3	Notification of shift from a common authentication to an individual certification.
	4	Notification of a common certification without ID2.
	5	Notification that no certification was issued.
	6	Notification that GW URL does not exist.

069	CERT: Up ID	The ID of the request for certification.
083	Firm Up Status	Displays the status of the firmware update.
085	Firm Up User Check	This SP setting determines if the operator can confirm the previous version of the firmware before the firmware update execution. If the option to confirm the previous version is selected, a notification is sent to the system manager and the firmware update is done with the firmware files from the URL.
086	Firmware Size	Allows the service technician to confirm the size of the firmware data files during the firmware update execution.
087	CERT: Macro Ver.	Displays the macro version of the @Remote certification.
088	CERT: PAC Ver.	Displays the PAC version of the @Remote certification.
089	CERT: ID2 Code	Displays ID2 for the @Remote certification. Spaces are displayed as underscores (_). Asterisks (*) indicate that no @Remote certification exists. "000000_____" indicates "Common certification".
090	CERT: Subject	Displays the common name of the @Remote certification subject. CN = the following 17 bytes. Spaces are displayed as underscores (_). Asterisks (*) indicate that no @Remote certification exists. "000000_____" indicates "Common certification".

091	CERT: SerialNo.	Displays serial number for the @Remote certification. Asterisks (*) indicate that no @Remote certification exists.
092	CERT: Issuer	Displays the common name of the issuer of the @Remote certification. CN = the following 30 bytes. Asterisks ( ) indicate that no @Remote certification exists.
093	CERT: Valid Start	Displays the start time of the period for which the current @Remote certification is enabled.
094	CERT: Valid End	Displays the end time of the period for which the current @Remote certification is enabled.
102*	CERT: Encrypt Level	
	<p>Displays the encryption level for the NRS certificate.</p> <p>[1 or 2 / 1 / -]</p> <p>1: Indicates that the certificate encryption level is 512-bit.</p> <p>2: Indicates that the certificate encryption level is 2048-bit.</p>	
200	Manual Polling	
	Executes the manual polling.	
201	Regist Status	
	<p>Displays a number that indicates the status of the @Remote service device.</p> <p>0: Neither the @Remote device nor Embedded RCG Gate is set.</p> <p>1: The Embedded RCG Gate is being set. Only Box registration is completed. In this status, @Remote device cannot communicate with this device.</p> <p>2: The Embedded RCG Gate is set. In this status, the @Remote device cannot communicate with this device.</p> <p>3: The @Remote device is being set. In this status the Embedded RCG Gate cannot be set.</p> <p>4: The @Remote module has not started.</p>	
202	Letter Number	Allows entry of the request number needed for the Embedded RCG Gate.

203	Confirm Execute	Executes the confirmation request to the @Remote Gateway.
204	Confirm Result	
	<p>Displays a number that indicates the result of the confirmation executed with SP5816-203.</p> <p>0: Succeeded                      1: Confirmation number error                      2: Registration in progress                      3: Proxy error (proxy enabled)                      4: Proxy error (proxy disabled)                      5: Proxy error (Illegal user name or password)                      6: Communication error                      7: Certification update error                      8: Other error                      9: Confirmation executing</p>	
	Confirm Place	
205	Displays the result of the notification sent to the device from the Gateway in answer to the confirmation request. Displayed only when the result is registered at the Gateway.	
206	Register Execute	Executes "Embedded RCG Registration".
	Register Result	
207	<p>Displays a number that indicates the registration result.</p> <p>0: Succeeded                      2: Registration in progress                      3: Proxy error (proxy enabled)                      4: Proxy error (proxy disabled)                      5: Proxy error (Illegal user name or password)                      6: Communication error                      7: Certification update error                      8: Other error                      9: Registration executing</p>	



208	Error Code		
	Displays a number that describes the error code that was issued when either SP5816-204 or SP5816-207 was executed.		
	<b>Cause</b>	<b>Code</b>	<b>Meaning</b>
	Illegal Modem Parameter	-11001	Chat parameter error
		-11002	Chat execution error
		-11003	Unexpected error
	Operation Error, Incorrect Setting	-12002	Inquiry, registration attempted without acquiring device status.
		-12003	Attempted registration without execution of an inquiry and no previous registration.
		-12004	Attempted setting with illegal entries for certification and ID2.
		-12005	@Remote communication is prohibited. The device has an Embedded RC gate-related problem.
		-12006	A confirmation request was made after the confirmation had been already completed.
		-12007	The request number used at registration was different from the one used at confirmation.
		-12008	Update certification failed because mainframe was in use.
		-12009	ID2 mismatch between an individual certification and NVRAM
-12010		Certification area is not initialized.	

	Error Caused by Response from GW URL	-2385	Attempted dial up overseas without the correct international prefix for the telephone number.
		-2387	Not supported at the Service Center
		-2389	Database out of service
		-2390	Program out of service
		-2391	Two registrations for same device
		-2392	Parameter error
		-2393	RCG device not managed
		-2394	Device not managed
		-2395	Box ID for RCG device is illegal
		-2396	Device ID for RCG device is illegal
		-2397	Incorrect ID2 format
		-2398	Incorrect request number format
209	Instl Clear	Releases the machine from its Embedded RCG Gate setup. <b>NOTE:</b> Turn off and on the main power switch after this setting has been changed.	
250	CommLog Print	Prints the communication log.	

Service Tables

5821*	Remote Service Address	
002	RCG IP Address	Sets the IP address of the RCG (Remote Communication Gate) destination for call processing at the remote service center. [00000000h to FFFFFFFFh / <b>00000000h</b> / 1]
003	RCG Port	Sets the port number of the RCG (Remote Communication Gate) destination for call processing at the remote service center. [0 to 65535 / <b>443</b> / 1]



Engine Main SP Tables-5

004	RCG URL Path	Sets the URL path of the RCG (Remote Communication Gate) destination for call processing at the remote service center. [0 to 16 characters / <b>/RCG/services/</b> /-]
-----	--------------	---

5824	NV-RAM Data Upload	
	Uploads the NVRAM data to an SD card. Push Execute. <b>Note:</b> When uploading data in this SP mode, the front door must be open.	

5825	NV-RAM Data Download	
	Downloads data from an SD card to the NVRAM in the machine. After downloading is completed, remove the card and turn the machine power off and on.	

5828	Network Setting	
050	1284 Compatibility (Centro)	Enables and disables bi-directional communication on the parallel connection between the machine and a computer. [0 to 1 / <b>1</b> / 1] 0:Off, 1: On
052	ECP (Centro)	Disables and enables the ECP feature (1284 Mode) for data transfer. [0 to 1 / <b>1</b> / 1] 0: Disabled, 1: Enabled
065	Job Spooling	Switches the job spooling on and off. [0 to 1 / <b>0</b> / 1] 0: No spooling, 1: Spooling enabled

066	Job Spooling Clear: Start Time	<p>This SP determines whether the job interrupted at power off is resumed at the next power on. This SP operates only when SP5828-065 is set to "1".</p> <p>[0 to 1 / 1 / 1]</p> <p>1: OFF Resumes printing spooled jog. 0: ON Clears spooled job.</p>
069	Job Spooling (Protocol)	<p>This SP determines whether job spooling is enabled or disabled for each protocol. This is a 8-bit setting.</p> <p>[0 to 1 / 1 / 1]</p> <p>0: No spooling, 1: Spooling enabled</p>
	0 LPR	4 BMLinks (Japan Only)
	1 FTP (Not Used)	5 DIPRINT
	2 IPP	6 SFTP
	3 SMB	7 WSPRND
087	@Remote Protocol Cnt ( <b>DFU</b> )	
090	TELNET (0:OFF 1:ON)	<p>Disables or enables Telnet operation. If this SP is disabled, the Telnet port is closed.</p> <p>[0 to 1 / 1 / 1]</p> <p>0: Disable, 1: Enable</p>
091	Web (0:OFF 1:ON)	<p>Disables or enables the Web operation.</p> <p>[0 to 1 / 1 / 1]</p> <p>0: Disable, 1: Enable</p>
145	Active IPv6 Link Local Address	<p>This is the IPv6 local address referenced on the Ethernet or wireless LAN (802.11) in the format: "Link-Local address" + "Prefix Length"</p> <p>The IPv6 address consists of a total 128 bits configured in 8 blocks of 16 bits each. These notations can be abbreviated. See "Note: IPV6 Addresses " below this table.</p>



147	Active IPv6 Stateless Address 1	<p>These SPs are the IPv6 stateless addresses (1 to 5) referenced on the Ethernet or wireless LAN (802.11) in the format:                      "Stateless Address" + "Prefix Length"</p> <p>The IPv6 address consists of a total 128 bits configured in 8 blocks of 16 bits each.</p>
149	Active IPv6 Stateless Address 2	
151	Active IPv6 Stateless Address 3	
153	Active IPv6 Stateless Address 4	
155	Active IPv6 Stateless Address 5	
156	IPv6 Manual Address	<p>This SP is the IPv6 manually set address referenced on the Ethernet or wireless LAN (802.11) in the format:                      "Manual Set Address" + "Prefix Length"</p> <p>The IPv6 address consists of a total 128 bits configured in 8 blocks of 16 bits each. These notations can be abbreviated. See "Note: IPV6 Addresses" below this table.</p>
158	IPv6 Gateway Address	<p>This SP is the IPv6 gateway address referenced on the Ethernet or wireless LAN (802.11). The IPv6 address consists of a total 128 bits configured in 8 blocks of 16 bits each. These notations can be abbreviated. See "Note: IPV6 Addresses" below this table.</p>
<p><b>Note: IPV6 Addresses</b></p> <p>Ethernet and the Wireless LAN (802.11) reference the IPV6 "Link-Local address + Prefix Length". The IPV6 address consists of 128 bits divided into 8 blocks of 16 bits:                      aaaa:bbbb:cccc:dddd:eeee:ffff:gggg:hhhh:</p> <p>The prefix length is inserted at the 17th byte (Prefix Range: 0x0 to 0x80). The initial setting is 0x40 (64).</p> <p>For example, the data: "2001123456789012abcdef012345678940h" is expressed:                      "2001:1234:5678:9012:abcd:ef01:2345:6789": prefixlen 64</p> <p>However, the actual IPV6 address display is abbreviated according to the following rules.</p>		

**Rules for Abbreviating IPV6 Addresses**

1. The IPV6 address is expressed in hexadecimal delimited by colons (:) with the following characters:  
0123456789abcdefABCDEF
2. A colon is inserted as a delimiter every 4th hexadecimal character.  
fe80:0000:0000:0000:0207:40ff:0000:340e
3. The notations can be abbreviated by eliminating zeros where the MSB and digits following the MSB are zero. The example in "2" above, then, becomes  
fe80:0:0:0207:40ff:0:340e
4. Sections where only zeros exist can be abbreviated with double colons (::). This abbreviation can be done also where succeeding sections contain only zeros (but this can be done only at one point in the address). The example in "2" and "3" above then becomes:  
fe80::207:40ff:0:340e (only the first null sets zero digits are abbreviated as "::")  
-or-  
fe80:0:0:0:207:40ff::340e (only the last null set before "340e" is abbreviated as "::")

161	IPv6 Stateless Auto Setting	Enable or disables the automatic setting for IPv6 stateless. [0 or 1 / 1 / 1] 1: Enable, 0: Disable
236	Web Item visible	
	Displays or does not display the Web system items. [0 x 0000 to 0 x ffff / 0 x ffff] 0: Not displayed, 1: Displayed bit0: Net RICOH bit1: Consumable Supplier bit2-15: Reserved (all)	
237	Web shopping link visible	
	Displays or does not display the link to Net RICOH on the top page and link page of the web system. [0 to 1 / 1 / 1] 0: Not display, 1:Display	



238	Web supplies Link visible	
	Displays or does not display the link to Consumable Supplier on the top page and link page of the web system. [0 to 1 / 1 / 1] 0: Not display, 1:Display	
239	Web Link1 Name	
	This SP confirms or changes the URL1 name on the link page of the web system. The maximum characters for the URL name are 31 characters.	
240	Web Link1 URL	
	his SP confirms or changes the link to URL1 on the link page of the web system. The maximum characters for the URL are 127 characters.	
241	Web Link1 visible	
	Displays or does not display the link to URL1 on the top page of the web system. [0 to 1 / 1 / 1] 0: Not display, 1:Display	
242	Web Link2 Name	Same as "-239"
243	Web Link2 URL	Same as "-240"
244	Web Link2 visible	Same as "-241"
249	DHCPv6 DUID	
	Sets DHCPv6 DUID. [00000000000000000000000000000000h to FFFFFFFFFFFFFFFFFFFFFFFFFFFFFFFFh / <b>00000000000000000000000000000000h / -]</b>	

5832	HDD
	Enter the SP number for the partition to initialize, then press #. When the execution ends, cycle the machine off and on.
001	HDD Formatting (All)

5834	Operation Panel Image Exposure Function
	<b>DFU</b>

5840*	IEEE 802.11	
006	Channel MAX	
	Sets the maximum range of the bandwidth for the wireless LAN. This bandwidth setting varies for different countries. [1 to 14 / <b>11 (NA), 13 (EU), 14 (JPN)</b> / 1] JPN: 1 to 14, NA: 1 to 11, EU: 1 to 13	
007	Channel MIN	
	Sets the minimum range of the bandwidth for operation of the wireless LAN. This bandwidth setting varies for different countries. [1 to 14 / <b>1</b> / 1] JPN: 1 to 14, NA: 1 to 11, EU: 1 to 13	
008	Transmission speed	[0 x 00 to 0 x FF / <b>0 x FF to Auto</b> / -]
	<b>0 x FF to Auto</b> [Default] 0 x 11 - 55M Fix 0 x 10 - 48M Fix 0 x 0F - 36M Fix 0 x 0E - 18M Fix 0 x 0D - 12M Fix 0 x 0B - 9M Fix 0 x 0A - 6M Fix	0 x 07 - 11M Fix 0 x 05 - 5.5M Fix 0 x 08 - 1M Fix 0 x 13 - 0 x FE (reserved) 0 x 12 - 72M (reserved) 0 x 09 - 22M (reserved)

Service  
Tables

011	WEP Key Select	
	Selects the WEP key. Bit 1 and 0 <b>00: Key1</b> , 01: Key2 (Reserved), 10: Key3 (Reserved), 11: Key4(Reserved) This SP is displayed only when the IEEE802.11 card is installed.	
042	Fragment Thresh	
	Adjusts the fragment threshold for the IEEE802.11 card. [256 to 2346 / <b>2346</b> / 1] This SP is displayed only when the IEEE802.11 card is installed.	
043	11g CTS to Self	
	Determines whether the CTS self function is turned on or off. [0 to 1 / <b>1</b> / 1] 0: Off, 1: On This SP is displayed only when the IEEE802.11 card is installed.	
044	11g Slot Time	
	Selects the slot time for IEEE802.11. [0 to 1 / <b>0</b> / 1] 0: 20 μm, 1: 9 μm This SP is displayed only when the IEEE802.11 card is installed.	
045	WPA Debug Lvl	
	Selects the debug level for WPA authentication application. [1 to 3 / <b>3</b> / 1] 1: Info, 2: warning, 3: error This SP is displayed only when the IEEE802.11 card is installed.	

5841*	Supply Name Setting	
	Press the User Tools key. These names appear when the user presses the Inquiry button on the User Tools screen.	
001	Toner Name Setting: Black	
011	StapleStd1	
012	StapleStd2	

013	StapleStd3	
014	StapleStd4	

5844	USB
001	Transfer Rate
	Sets the speed for USB data transmission. [0 x 01 or 0 x 04 / <b>0 x 04</b> /-] 0 x 01 [Full Speed], 0 x 04 [Auto Change]
002	Vendor ID
	Sets the vendor ID: Initial Setting: 0x05A Ricoh Company [0x0000 to 0xFFFF/1] ( <b>DFU</b> )
003	Product ID
	Sets the product ID. [0x0000 to 0xFFFF/1] ( <b>DFU</b> )
004	Device Release No.
	Sets the device release number of the BCD (binary coded decimal) display. [0000 to 9999 / <b>100</b> / 1] ( <b>DFU</b> ) Enter as a decimal number. NCS converts the number to hexadecimal number recognized as the BCD.
005	Fixed USB Port
	This SP standardizes for common use the model name and serial number for USB PnP (Plug & Play). It determines whether the driver requires re-installation. [0 to 2 / <b>0</b> / 1] 0: OFF 1: Level 1 2: Level 2





006	PnP Model Name
	<p>This SP sets the model name to be used by the USB PnP when "Function Enable (Level 2) is set so the USB Serial No. can have a common name (SP5844-5).</p> <p>Default: <b>Laser Printer</b> (up to 20 characters allowed).</p>
007	PnP Serial Number
	<p>This SP sets the serial number to be used by the USB PnP when "Function Enable (Level 2) set so the USB Serial No. can have a common name (SP5844-5).</p> <p>Default: None (up to 12 characters allowed for entry).</p> <ul style="list-style-type: none"> <li>▪ Make sure that this entry is the same as the serial number in use.</li> <li>▪ At initialization the serial number generated from the model name is used, not the setting of this SP code.</li> <li>▪ At times other than initialization, the value set for this SP code is used.</li> </ul>
008	Mac Supply Level
	<p>This SP switches of and on the Mac supply level function.</p> <p>[0 to 1 / 1 / 1]</p> <p>0: OFF</p> <p>1: ON</p>
100	Notify Unsupport
	<p>This SP determines whether an alert message appears on the control panel when a USB device (unsupported device) that cannot use an A-connector is connected.</p> <p>[0 to 1 / 1 / 1]</p> <p>0: Function enable</p> <p>1: Function disable</p> <ul style="list-style-type: none"> <li>▪ An unsupported device is a device that cannot use the functions of the USB device. For example, a USB mouse cannot be used even if it connected.</li> <li>▪ If the PictBridge option is not mounted, even if a digital camera is connected it cannot be used because it is an unsupported device.</li> </ul>

5845*	Delivery Server Setting	
	These are delivery server settings.	
003	Delivery Retry Interval	
	[60 to 900 / <b>300</b> / 1 /step] Sets the wait time from the error action to the retry.	
004	Delivery Retry times	
	[0 to 99 / <b>3</b> / 1time(s) /step] Sets how many times to retry.	
022	Rapid Sending Control	[0 to 1 / <b>1</b> / -] 0: Disable, 1: Enable
	Enables or disables the prevention function for the continuous data sending error.	

5846*	UCS Setting	
010	LDAP Search Timeout	
	Sets the length of the time-out for the search of the LDAP server. [1 to 255 / <b>60</b> /1 step]	
041	Fill Addr Acl Info.	
	<p>This SP must be executed immediately after installation of an HDD unit in a basic machine that previously had no HDD. The first time the machine is powered on with the new HDD installed, the system automatically takes the address book from the NVRAM and writes it onto the new HDD. However, the new address book on the HDD can be accessed only by the system administrator at this stage. Executing this SP by the service technician immediately after power on grants full address book access to all users.</p> <p><b>Procedure</b></p> <ol style="list-style-type: none"> <li>1. Turn the machine off.</li> <li>2. Install the new HDD.</li> <li>3. Turn the machine on.</li> <li>4. The address book and its initial data are created on the HDD automatically. However, at this point the address book can be accessed by only the system administrator or key operator.</li> <li>5. Enter the SP mode and do SP5846 041. After this SP executes successfully, any user can access the address book.</li> </ol>	
043	Addr Book Media	
	Displays the slot number where an address book data is in. [0 to 30 / - /1]	
	0: Unconfirmed 1: SD Slot 1 2: SD Slot 2 4: USB Flash ROM	20: HDD 30: Nothing
047	Initialize Local Address Book	
	Clears all of the address information from the local address book of a machine managed with UCS.	

049	Initialize LDAP Addr Book	
	Push [Execute] to delete all items (this does not include user codes) in the LDAP address book that is controlled by UCS.	
050	Initialize All Addr Book	
	Clears everything (including users codes) in the directory information managed by UCS. However, the accounts and passwords of the system administrators are not deleted.	
051	Backup All Addr Book	
	Copies all directory information to the SD card. Do this SP before replacing the controller board or HDD. The operation may not succeed if the controller board or HDD is damaged.	
052	Restore All Addr Book	
	Copies back all directory information from the SD card to the flash ROM or HDD. Upload the address book from the old flash ROM or HDD with SP5846-51 before removing it. Do SP5846 52 after installing the new HDD.	
053	Clear Backup Info	
	<p>Deletes the address book uploaded from the SD card in the slot 2. Deletes only the files uploaded for that machine. This feature does not work if the card is write-protected.</p> <p>Note: After you do this SP, go out of the SP mode, turn the power off. Do not remove the SD card until the Power LED stops flashing.</p>	
060	Search Option	
	This SP uses bit switches to set up the fuzzy search options for the UCS local address book.	
	<b>Bit</b>	<b>Meaning</b>
	0	Checks both upper/lower case characters
	1	<b>Japan Only</b>
	2	
3		



	4	--- Not Used ---
	5	--- Not Used ---
	6	--- Not Used ---
	7	--- Not Used ---
062	Complexity Option 1	
	<p>Use this SP to set the conditions for password entry to access the local address book. Specifically, this SP limits the password entry to upper case and sets the length of the password.</p> <p>[0 to 32 / 0 / 1step]</p> <p><b>Note</b></p> <ul style="list-style-type: none"> <li>▪ This SP does not normally require adjustment.</li> <li>▪ This SP is enabled only after the system administrator has set up a group password policy to control access to the address book.</li> </ul>	
063	Complexity Option 2	
	<p>Use this SP to set the conditions for password entry to access the local address book. Specifically, this SP limits the password entry to lower case and defines the length of the password.</p> <p>[0 to 32 / 0 / 1step]</p> <p><b>Note</b></p> <ul style="list-style-type: none"> <li>▪ This SP does not normally require adjustment.</li> <li>▪ This SP is enabled only after the system administrator has set up a group password policy to control access to the address book.</li> </ul>	
064	Complexity Option 3	
	<p>Use this SP to set the conditions for password entry to access the local address book. Specifically, this SP limits the password entry to numbers and defines the length of the password.</p> <p>[0 to 32 / 0 / 1step]</p> <p><b>Note</b></p> <ul style="list-style-type: none"> <li>▪ This SP does not normally require adjustment.</li> <li>▪ This SP is enabled only after the system administrator has set up a group password policy to control access to the address book.</li> </ul>	

065	Complexity Option 4
	<p>Use this SP to set the conditions for password entry to access the local address book. Specifically, this SP limits the password entry to symbols and defines the length of the password.</p> <p>[0 to 32 / 0 / 1step]</p> <p><b>Note</b></p> <ul style="list-style-type: none"> <li>This SP does not normally require adjustment.</li> <li>This SP is enabled only after the system administrator has set up a group password policy to control access to the address book.</li> </ul>
094	Encryption Start
	<p>Shows the status of the encryption function of the address book on the LDAP server.</p> <p>[0 to 255 / 1 ] No default</p>

5848*	Web Service	
	<p>5848-2 sets the 4-bit switch assignment for the access control setting. Setting of 0001 has no effect on access and delivery from Scan Router.</p> <p>5848-100 sets the maximum size of images that can be downloaded. The default is equal to 1 gigabyte.</p>	
004	Acc. Ctrl.: User Directory (Lower 4 Bits)	Switches access control on and off. 0000: OFF, 0001: ON
009	Acc. Ctrl.: Job Control (Lower 4 Bits)	
011	Acc. Ctrl: Device Management (Lower 4 Bits)	
022	Acc. Ctrl: User Administration (Lower 4 Bits)	
210	Setting: Log Type: Job 1	
	No information is available at this time.	
211	Setting: Log Type: Job 2	
	No information is available at this time.	
212	Setting: Log Type: Access	
	No information is available at this time.	

Engine Main SP Tables-5

213	Setting: Primary Srv
	No information is available at this time.
214	Setting: Secondary Srv
	No information is available at this time.
215	Setting: Start Time
	No information is available at this time.
216	Setting: Interval Time
	No information is available at this time.
217	Setting: Timing
	No information is available at this time.

5849	Installation Date	
	Displays or prints the installation date of the machine.	
001	Display	The "Counter Clear Day" has been changed to "Installation Date" or "Inst. Date".
002	Switch to Print	Determines whether the installation date is printed on the printout for the total counter. [0 to 1 / 1 / -] 0: OFF (No Print) 1: ON (Print)
003	Total Counter	When the total number of pages that are made reaches this value, the current date becomes the 'official' installation date for this machine. [0 to 99999999 / 0 / 1]

5856	Remote ROM Update
002	<p>When set to "1" allows reception of firmware data via the local port (IEEE 1284) during a remote ROM update. This setting is reset to zero after the machine is cycled off and on. Allows the technician to upgrade the firmware using a parallel cable</p> <p>[0 to 1 / 0 / 1 step]</p> <p>0: Not allowed</p> <p>1: Allowed</p>

5857	Save Debug Log
001	<p>On/Off (1:ON 0:OFF)</p> <p>Switches on the debug log feature. The debug log cannot be captured until this feature is switched on.</p> <p>[0 to 1 / 0 / 1]</p> <p>0: OFF, 1: ON</p>
002	<p>Target (2: HDD 3: SD)</p> <p>Selects the destination where the debugging information generated by the event selected by SP5858 will be stored if an error is generated</p> <p>[2 to 3 / 2 / 1]</p> <p>2: HDD, 3: SD Card</p>
005	<p>Save to HDD</p> <p>Specifies the decimal key number of the log to be written to the hard disk.</p>
006	<p>Save to SD Card</p> <p>Specifies the decimal key number of the log to be written to the SD Card.</p>
009	<p>Copy HDD to SD Card (Latest 4 MB)</p> <p>Takes the most recent 4 MB of the log written to the hard disk and copies them to the SD Card.</p> <p>A unique file name is generated to avoid overwriting existing file names on the SD Card. Up to 4MB can be copied to an SD Card. 4 MB segments can be copied one by one to each SD Card.</p>





010	Copy HDD to SD Card Latest 4 MB Any Key)
	<p>Takes the log of the specified key from the log on the hard disk and copies it to the SD Card.</p> <p>A unique file name is generated to avoid overwriting existing file names on the SD Card. Up to 4 MB can be copied to an SD Card. 4 MB segments can be copied one by one to each SD Card. This SP does not execute if there is no log on the HDD with no key specified.</p>
011	Erase HDD Debug Data
	Erases all debug logs on the HDD
012	Erase SD Card Debug Data
	<p>Erases all debug logs on the SD Card. If the card contains only debugging files generated by an event specified by SP5858, the files are erased when SP5857 010 or 011 is executed.</p> <p>To enable this SP, the machine must be cycled off and on.</p>
013	Free Space on SD Card
	Displays the amount of space available on the SD card.
014	Copy SD to SD (Latest 4MB)
	Copies the last 4MB of the log (written directly to the card from shared memory) onto an SD card.
015	Copy SD to SD (Latest 4MB Any Key)
	This SP copies the log on an SD card (the file that contains the information written directly from shared memory) to a log specified by key number.
016	Make HDD Debug
	This SP creates a 32 MB file to store a log on the HDD.
017	Make SD Debug
	This SP creates a 4 MB file to store a log on an SD card.

5858*	Debug Save When	
	These SPs select the content of the debugging information to be saved to the destination selected by SP5857-002. SP5858-003 stores one SC specified by number.	
001*	Engine SC Error (0:OFF 1:ON)	Stores SC codes generated by copier engine errors.
002*	Controller SC Error (0:OFF 1:ON)	Stores SC codes generated by GW controller errors.
003*	Any SC Error	[0 to 65535 / 0 / 1step]
004*	Jam (0:OFF 1:ON)	Stores jam errors.

5859*	Debug Save Key No.	
001	Key 1	These SPs allow you to set up to 10 keys for log files for functions that use common memory on the controller board. [0 to 9999999 / 0 / 1]
002	Key 2	
003	Key 3	
004	Key 4	
005	Key 5	
006	Key 6	
007	Key 7	
008	Key 8	
009	Key 9	
010	Key 10	

5860*	SMTP/POP3/IMAP4	
002	SMTP Server Port Number	
	This SP sets the number of the SMTP server port. [1 to 65535 / 25 / 1]	



003	SMTP Authentication
	This setting switches SMTP certification on and off for mail sending. [0 or 1 / <b>0</b> / -] 0: Off, 1: On
006	SMTP Auth. Encryption
	This setting determines whether the password for SMTP certification is encrypted. [0 to 2 / <b>0</b> / 1] 0: Automatic, 1: No encryption done, 2: Encryption done
007	POP before SMTP
	This setting determines whether the transmission connects with the POP server first for certification before it connects to the SMTP server for sending. [0 or 1 / <b>0</b> / -] 0: No connection to POP server 1: Connection to POP server
008	POP to SMTP Waiting Time
	This SP sets the amount of time to allow for the connection to the SMTP server after the transmission has connected to the POP server and been certified during the execution of POP Before SMTP. [0 to 10000 / <b>300</b> / 1 ms]
009	Mail Receive Protocol
	This SP specifies a protocol for the mail reception or switches off receiving. [1 to 3 / <b>1</b> / 1] 1: POP3 protocol, 2: IMAP4 protocol, 3: SMTP protocol
013	POP3/IMAP4 Auth. Encryption
	This SP specifies whether password encryption is done for POP3/IMAP4 certification. [0 to 2 / <b>0</b> / 1] 0: Automatic, 1: No encryption done, 2: Encryption done

014	POP3 Server Port Number
	This SP sets the number of the POP3 server port. [1 to 65535 / <b>110</b> / 1]
015	IMAP4 Server Port Number
	This SP sets the number of the IMAP4 server port. [1 to 65535 / <b>143</b> / 1]
016	SMTP Receive Port Number
	This SP sets the number of the port that receives SMTP mail. [1 to 65535 / <b>25</b> / 1]
017	Mail Receive Interval
	This SP sets the timing for mail received at regular intervals. [2 to 1440 / <b>3</b> / 1 min.]
019	Mail Keep Setting
	This SP setting determines whether received mail is stored on the server. [0 to 2 / <b>0</b> / 1] 0: Received mail not stored 1: All received mail stored 2: Stores only mail that generated errors during receiving
020	Partial Mail Receive Timeout
	[1 to 168 / <b>72</b> / 1 hour] Sets the amount of time to wait before saving a mail that breaks up during reception. The received mail is discarded if the remaining portion of the mail is not received during this prescribed time.
021	MDN Response RFC2298 Compliance
	Determines whether RFC2298 compliance is switched on for MDN reply mail. [0 to 1 / <b>1</b> / 1] 0: No, 1: Yes

	SMTP Auth. From Field Replacement	
022	Determines whether the FROM item of the mail header is switched to the validated account after the SMTP server is validated. [0 to 1 / 0 / 1] 0: No. "From" item not switched. 1: Yes. "From" item switched.	
	SMTP Auth Direct Sending	
025	Select the authentication method for SMPT. Bit 0: LOGIN Bit 1: PLAIN Bit 2: CRAM_MD5 Bit 3: DIGEST_MD5 Bit 4 to Bit 7: Not Used <div style="border: 1px solid blue; border-radius: 10px; padding: 2px; display: inline-block;">  <b>Note</b> </div> <ul style="list-style-type: none"> <li>▪ This SP is activated only when SMTP authentication is enabled by UP mode.</li> </ul>	
	S/MIME: MIME Header Setting	
026	Selects the MIME header type of an E-mail sent by S/MIME. [0 to 2 / 0 / 1] 0: Microsoft Outlook Express standard 1: Internet Draft standard 2: RFC standard	

5869	RAM Disk Setting	
001	Mail Function	Enables or disables the Mail function. [0 or 1 / 0 / - ] 0: Enabled, 1: Disabled

5870	Common Key Info Writing	
001	Writing	Writes to flash ROM the common proof for validating the device for @Remote specifications.
003	Initialize	Initializes the data area of the common proof for validating.

004	Writing: 2048bit	Writes to flash ROM the common proof (2048-bit) for validating the device for @Remote specifications.
-----	---------------------	---

5873	SD Card Appli. Move	
	Allows you to move applications from one SD card another. For more, see "SD Card Appli Move" in the chapter "System Maintenance (Main Chapters).	
001	Move Exec	Executes the move from one SD card to another.
002	Undo Exec	This is an undo function. It cancels the previous execution.

5878	Option Setup	
001	Data Overwrite Security	Press [Execute] to initialize the Data Overwrite Security option for the copier. For more, see "DataOverwriteSecurity Unit" in the chapter "Installation".

5881	Fixed Phrase Block Erasing	
	Detects the Fixed phrase.	

5887	SD Get Counter	
	This SP determines whether the ROM can be updated.	
001	<p>This SP sends a text file to an SD card inserted in SD card Slot 2 (lower slot). The operation stores. The file is stored in a folder created in the root directory of the SD card called SD_COUNTER. The file is saved as a text file (*.txt) prefixed with the number of the machine.</p> <ol style="list-style-type: none"> <li>1. Insert the SD card in SD card Slot 2 (lower slot).</li> <li>2. Select SP5887 then touch [EXECUTE].</li> </ol> <p>Touch [Execute] in the message when you are prompted.</p>	



5888*	Personal Information Protect
	<p>Selects the protection level for logs.                  [0 to 1 / 0 / 1]                  0: No authentication, No protection for logs                  1: No authentication, Protected logs (only an administrator can see the logs)</p>

5893	SDK Application Counter
	Displays the counter name of each SDK application.
001	SDK-1
002	SDK-2
003	SDK-3
004	SDK-4
005	SDK-5
006	SDK-6

5907	Plug & Play Maker/Model Name
	<p>Selects the brand name and the production name for Windows Plug &amp; Play. This information is stored in the NVRAM. If the NVRAM is defective, these names should be registered again.                  After selecting, press the "Original Type" key and "#" key at the same time. When the setting is completed, the beeper sounds five times.</p>

5930	Meter Charge
001	Display Operation State
	<p>0: OFF                  1: ON</p>

5985	Device Setting	
	The USB support feature is built into the GW controller. Use this SP to enable and disable the features. In order to use the USB function built into the controller board, this SP code must be set to "1".	
002	On Board USB	[0 or 1 / 0 / 1/step] 0: Disable, 1: Enable

5990	SP Print Mode	
	Prints out the SMC sheets.	
001	All ( Data List)	
002	SP (Mode Data List)	
004	Logging Data	
005	Diagnostic Report	
006	Non-Default	
007	NIB Summary	
024	SDK/J Summary	
025	SDK/J Application Info	
026	Printer SP	





## 5.9 ENGINE MAIN SP TABLES-6

### 5.9.1 SP6-XXX: PERIPHERALS

6128	Punch Position: Sub Scan	
	Adjusts the punching position in the sub scan direction. (For D636)	
001	2-Hole: DOM (Japan)	[-7.5 to 7.5 / <b>0</b> / 0.5 mm]
002	3-Hole: NA	
003	4-Hole: EU	
004	5-Hole: SCAN	
005	2-Hole: NA	

6129	Punch Position: Main Scan	
	Adjusts the punching position in the main scan direction. (For D636)	
001	2-Hole: DOM (Japan)	[-2 to 2 / <b>0</b> / 0.4 mm]
002	3-Hole: NA	
003	4-Hole: EU	
004	4-Hole: SCAN	
005	2-Hole: NA	

6130*	Skew Correction: Buckle Adj.	
	Adjusts the paper buckle at the punch unit for each paper size. (For D636)	
001	A3 SEF	[-5 to 5 / <b>0</b> / 0.25 mm]
002	B4 SEF	
003	A4 SEF	
004	A4 LEF	

005	B5 SEF	
006	B5 LEF	
007	DLT SEF	
008	LG SEF	
009	LT SEF	
010	LT LEF	
011	12" x 18"	
012	Other	

6131*	Skew Correction Control	
	Selects the skew correction control for each paper size. (For D636)	
001	A3 SEF	[0 to 1 / 1 / 1 mm]
002	B4 SEF	
003	A4 SEF	
004	A4 LEF	
005	B5 SEF	
006	B5 LEF	
007	DLT SEF	
008	LG SEF	
009	LT SEF	
010	LT LEF	
011	12" x 18"	
012	Other	



6132*	Jogger Fence Fine Adj.	
	This SP adjusts the distance between the jogger fences and the sides of the stack on the finisher stapling tray in the Finisher D636. The adjustment is done perpendicular to the direction of paper feed.	
001	A3 SEF	[-1.5 to 1.5 / <b>0</b> / 0.5 mm]
002	B4 SEF	
003	A4 SEF	
004	A4 LEF	
005	B5 SEF	
006	B5 LEF	
007	DLT SEF	
008	LG SEF	
009	LT SEF	
010	LT LEF	
011	12" x 18"	
012	Other	

6133*	Staple Position Adjustment	
	Adjusts the staple position for each finisher (D636). + Value: Moves the staple position to the rear side. - Value: Moves the staple position to the front side. [-3.5 to 3.5 / <b>0</b> / 0.5 mm]	

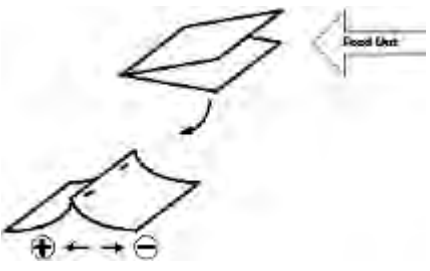
6134*	Saddle Stitch Position Adj. <b>(Not used)</b>	
	Use this SP to adjust the stapling position of the booklet stapler when paper is stapled and folded in the Booklet Finisher (D637).	
001	A3 SEF	<p>[-3 to 3 / <b>0</b> / 0.2 mm]</p> <p>+ Value: Shifts staple position toward the crease. - Value: Shifts staple position away from the crease</p> 
002	B4 SEF	
003	A4 SEF	
004	B5 SEF	
005	DLT SEF	
006	LG SEF	
007	LT SEF	
008	12" x 18"	
009	Other	

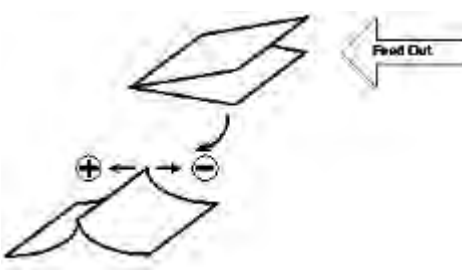
6135*	Folder Position Adj. <b>(Not used)</b>	
	This SP corrects the folding position when paper is stapled and folded in the Booklet Finisher D637.	
001	A3 SEF	<p>[-3 to 3 / <b>0</b> / 0.2 mm]</p> <p>+ Value: Shifts staple position toward the crease. - Value: Shifts staple position away from the crease.</p> 
002	B4 SEF	
003	A4 SEF	
004	B5 SEF	
005	DLT SEF	
006	LG SEF	
007	LT SEF	
008	12" x 18"	
009	Other	

Service Tables

Engine Main SP Tables-6

6136*	Book Fold Repeat <b>(Not used)</b>
	Sets the number of times that folding is done in the Booklet Finisher D637. [2 to 30 / <b>2</b> / 1 time/step]

6139	Entrance Sensor
	Display the signals received from sensors and switches of the finisher. (D588) (☛ p.5-127 "Input Check Table")

6140	FIN (EUP) INPUT Check
	Display the signals received from sensors and switches of the finisher. (D636) (☛ p.5-127 "Input Check Table")

6144	FIN (KIN) OUPUT Check
	Display the signals received from sensors and switches of the finisher. (D588) (☛ p.5-137 "Output Check Table")

6145	FIN (EUP) OUPUT Check
	Display the signals received from sensors and switches of the finisher. (D636) (☛ p.5-137 "Output Check Table")

6148	Jogger Fine Adj.	
001	A3T	Adjusts the jogger location [Horizontal direction] [-1.5 to 1.5 / <b>0</b> / 0.5 /mm] *Jogger is optional equipment.
002	B4T	
003	A4T	
004	A4Y	
005	B5Y	
006	A5Y	
007	DLT-T	

008	LG-T	
009	LT-T	
010	LT-Y	
011	HLT-Y	
012	Other	

6149*	Max. Pre-Stack Sheet	[0 to 3 / <b>3</b> / 1 sheets step]
	<p>This SP sets the number of sheets sent to the pre-stack tray.</p> <p> <b>Note</b></p> <ul style="list-style-type: none"> <li>You may need to adjust this setting or switch it off when feeding thick or slick paper.</li> </ul>	

6150	Jogger Control
001	<p>Enables or disables the jogger.</p> <p>[0 to 1 / <b>0</b> / 1 /step]</p> <p>0: Disable. 1: Enable</p>

## 5.10 ENGINE MAIN SP TABLES-7

### 5.10.1 SP7-XXX: DATA LOG

7401*	Total SC Counter
001	SC Counter
	Displays the total number of service calls that have occurred. This SC counter can be reset by executing SP7807 (SC/Jam Counter Reset).
002	Total SC Counter
	Displays the cumulative sum of service calls that have occurred. This SC counter cannot be reset by executing SP7807 (SC/Jam Counter Reset).

7403*	SC History	
001	Latest	Displays the most recent 10 service calls.
002	Latest 1	
003	Latest 2	
004	Latest 3	
005	Latest 4	
006	Latest 5	
007	Latest 6	
008	Latest 7	
009	Latest 8	
010	Latest 9	

7502*	Total Paper Jam
001	Jam Counter
	Displays the total number of paper jams. This SC counter can be reset by executing SP7807 (SC/Jam Counter Reset).
002	Total Jam Counter
	Displays the cumulative sum of paper jams. This SC counter cannot be reset by executing SP7807 (SC/Jam Counter Reset).

7504*	Total Jams Location
	These SPs display the total number of paper jams by location. A "Check-in" (paper late) error occurs when the paper fails to activate the sensor at the precise time. A "Check-out" ("paper lag") paper jam occurs when the paper remains at the sensor for longer than the prescribed time.
001	At power On
003	Tray 1: On
004	Tray 2: On
005	Tray 3: On
006	Tray 4: On
007	LCT: On
008	Bypass: On
009	Duplex: On
011	Vertical Transport 1: On
012	Vertical Transport 2: On
013	Bank: Transport Sn 1: On
014	Bank: Transport Sn 2: On





Engine Main SP Tables-7

017	Registration: On
019	Fusing Exit: On
020	Paper Exit: On
021	Bridge Exit On
022	Bridge Transport: On
024	Junction Gate Sensor: On
025	Duplex Exit: On
026	Duplex Entrance: On (In)
027	Duplex Entrance: On (Out)
051	Vertical Transport 1: Off
052	Vertical Transport 2: Off
053	Bank Transport 1: Off
054	Bank Transport 2: Off
057	Registration Sensor: Off
058	LCT Feed Sensor: Off
060	Paper Exit: Off
061	Bridge: Exit: Off
062	Bridge: Transport: Off
064	Junction Gate Sensor: Off
065	Duplex Exit: Off
066	Duplex Entrance: Off (In)
067	Duplex Entrance: Off (Out)
100	Finisher Entrance: KIN
101	Finisher Shift Tray Exit: KIN
102	Finisher Staple: KIN

103	Finisher Exit: KIN
105	Finisher Tray Lift Motor: KIN
106	Finisher Jogger Motor: KIN
107	Finisher Shift Motor: KIN
108	Finisher Staple Motor: KIN
109	Finisher Exit Motor: KIN
191	Finisher Entrance: EUP
192	Finisher Proof Exit: EUP
193	Finisher Shift Tray Exit: EUP
194	Finisher Staple Exit: EUP
195	Finisher Exit: EUP
198	Finisher Folder: EUP
199	Finisher Tray Motor: EUP
200	Finisher Jogger Motor: EUP
201	Finisher Shift Motor: EUP
202	Finisher Staple Moving Motor: EUP
203	Finisher Staple Motor: EUP
204	Finisher Folder Motor: EUP
206	Finisher Punch Motor: EUP

Service  
Tables

7506*	Jam Count by Paper Size	
005	A4 LEF	Displays the total number of copy jams by paper size.
006	A5 LEF	
014	B5 LEF	
038	LT LEF	

Engine Main SP Tables-7

044	HLT LEF	
132	A3 SEF	
133	A4 SEF	
134	A5 SEF	
141	B4 SEF	
142	B5 SEF	
160	DLT SEF	
164	LG SEF	
166	LT SEF	
172	HLT SEF	
255	Others	

7507*	Plotter Jam History				
001	Last	<p>Displays the copy jam history (the most recent 10 jams)</p> <p>Sample Display:</p> <p>CODE:007</p> <p>SIZE:05h</p> <p>TOTAL:0000334</p> <p>DATE: Mon Mar 15 11:44:50 2000</p> <p>where:</p> <p>CODE is the SP7504-*** number (see above).</p> <p>SIZE is the ASAP paper size code in hex.</p> <p>TOTAL is the total jam error count (SP7502)</p> <p>DATE is the date the jams occurred.</p>			
002	Latest 1				
003	Latest 2				
004	Latest 3				
005	Latest 4				
006	Latest 5				
007	Latest 6				
008	Latest 7				
009	Latest 8				
010	Latest 9				
Size	Code	Size	Code	Size	Code
A4 (S)	05	A3 (L)	84	DLT (L)	A0

A5 (S)	06	A4 (L)	85	LG (L)	A4
B5 (S)	0E	A5 (L)	86	LT (L)	A6
LT (S)	26	B4 (L)	8D	HLT (L)	AC
HLT (S)	2C	B5 (L)	8E	Others	FF

7801	ROM No./Firmware Version
	This SP code displays the firmware versions of all ROMs in the system, including the mainframe, the ARDF, and peripheral devices.

7803*	PM Counter Display
	Displays the PM counter since the last PM.
001	Paper [0 to 999999 / 0 / 1 page]
	Displays the paper counter (pages)
002	Page: PCD [0 to 999999 / 0 / 1 page]
	Displays the PCD (Drum and Development unit) counter (pages)
003	Page: Transfer [0 to 999999 / 0 / 1 page]
	Displays the transfer unit counter (pages).
004	Page: Fuser [0 to 999999 / 0 / 1 page]
	Displays the fusing unit counter (pages).
005	Rotation: PCD [0 to 999999999 / 0 / 1 mm ]
	Displays the PCD rotation counter (distance).
006	Rotation: Transfer [0 to 999999999 / 0 / 1 mm ]
	Displays the transfer unit rotation counter (distance).
007	Rotation: Fuser [0 to 999999999 / 0 / 1 mm ]
	Displays the fuser unit rotation counter (distance).

Service Tables

008	Rotation(%): PCD	[0 to 255 / 0 / 1 %]
	Displays the PCD (%) rotation counter (Distance/PM).	
009	Rotation(%):Transfer	[0 to 255 / 0 / 1 %]
	Displays the transfer unit (%) rotation counter (distance/PM).	
010	Rotation(%):Fuser	[0 to 255 / 0 / 1 %]
	Displays the fuser unit (%) rotation counter (distance/PM).	
011	Rotation(%):Web	[0 to 255 / 0 / 1 %]
	Displays the web unit (%) rotation counter (distance/PM).	

7804	PM Counter Reset
	Resets the PM counter. Touch [Execute] two times > "Completed" > [Exit]
001	Paper
	Resets the PM counter of the paper.
002	PCD
	Resets the PM counter of the PCD (Drum and Development unit except developer).
003	Transfer
	Resets the PM counter of the transfer unit.
004	Fuser
	Resets the PM counter of the fuser unit.
005	Web
	Reset the PM counter of the web unit.
006	All Clear
	Resets all PM counter

7807	SC/Jam Counter Reset	
	Resets the SC and jam counters. To reset, press Execute on the touch panel. This SP does not reset the jam history counters: SP7507, SP7508.	

7832	Self-Diagnose Result Display	
	Execute to open the "Self-Diagnostics Result Display" to view details about errors. Use the keys in the display on the touch-panel to scroll through all the information. If no errors have occurred, you will see the "No Error" message on the screen.	

7836	Total Memory Size	
	Displays the memory capacity of the controller system.	

7853	Replacement Counter	
001	PCD	[0 to 255 / 0 / 1 ]
	Displays the replacement counter of the PCD (Drum and Development unit).	
002	Transfer	[0 to 255 / 0 / 1 ]
	Displays the replacement counter of the transfer unit.	
003	Fuser	[0 to 255 / 0 / 1 ]
	Displays the replacement counter of the fusing unit.	
004	Web	[0 to 255 / 0 / 1 ]
	Displays the replacement counter of the cleaning web.	



Engine Main SP Tables-7

7904	Near End Setting	
001*	PCD	Sets the near end timing setting for each maintenance item. [0 to 2/ 1 / 1 /step] 0: Earlier 1: Normal 2: Later
002*	Transfer	
003*	Fuser	

7906	Prev Counter	
001	Page: PCD	[0 to 999999 / 0 / 1 page]
	Displays the counter (pages) of the previous PCD	
002	Page: Transfer	[0 to 999999 / 0 / 1 page]
	Displays the previous counter (pages) of the previous transfer unit.	
003	Page: Fuser	[0 to 999999 / 0 / 1 page]
	Displays the previous counter (pages) of the previous fusing unit.	
004	Rotation: PCD	[0 to 999999999 / 0 / 1 mm ]
	Displays the previous counter (rotations) of the previous PCD	
005	Rotation: Transfer	[0 to 999999999 / 0 / 1 mm ]
	Displays the previous counter (rotations) of the previous transfer unit.	
006	Rotation: Fuser	[0 to 999999999 / 0 / 1 mm ]
	Displays the previous counter (rotations/PM %) of the previous fusing unit.	
007	Rotation(%):PCD	[0 to 255 / 0 / 1 mm]
	Displays the previous counter (rotations/PM %) of the previous PCD	
008	Rotation(%):Transfer	[0 to 255 / 0 / 1 mm]
	Displays the previous counter (rotations/PM %) of the previous transfer unit.	

009	Rotation(%):Fuser	[0 to 255 / 0 / 1 mm]
	Displays the previous counter (rotations/PM %) of the previous fusing unit.	
010	Rotation(%):Web	[0 to 255 / 0 / 1 %]
	Displays the previous counter (rotations/PM %) of the previous cleaning web.	

7910	ROM No		
	Indicate the ROM number for the machine components. These SPs are listed in the SMC Report, they are not displayed on the operation panel.		
001	System/Copy	159	PCLXL
002	Engine	160	MSIS
003	Lcdc	162	PDF
005	ADF	163	BMLinkS
007	Finisher	165	PJL
009	Bank	166	IPDS
010	LCT	167	MediaPrint:JPEG
018	NetworkSupport	168	MediaPrint:TIFF
019	Bank 2	180	FONT
022	BIOS	181	FONT1
023	HDD Format Option	182	FONT2
100	Language1	183	FONT3
101	Language2	184	FONT4
132	NetWare	185	FONT5
150	RPCS	200	Factory
151	PS	202	NetworkDocBox

Service  
Tables



Engine Main SP Tables-7

152	RPDL	204	Printer
153	R98	210	MIB
154	R16	211	Websupport
155	RPGL	213	SDK1
156	R55	214	SDK2
157	RTIFF	215	SDK3
158	PCL		

7911	Firmware Version		
	Indicate the firmware version for the machine components. These SPs are listed in the SMC Report, but they are not displayed on the operation panel.		
002	Engine	162	PDF
003	Lcdc	163	BMLinkS
018	NetworkSupport	165	PJL
022	BIOS	166	IPDS
023	HDD Format Option	167	MediaPrint:JPEG
100	Language1	168	MediaPrint:TIFF
101	Language2	180	FONT
105	ADF	181	FONT1
107	Finisher	182	FONT2
132	NetWare	183	FONT3
150	RPCS	184	FONT4
151	PS	185	FONT5
152	RPDL	200	Factory
153	R98	202	NetworkDocBox

154	R16	204	Printer
155	RPGL	210	MIB
156	R55	211	Websupport
157	RTIFF	213	SDK1
158	PCL	214	SDK2
159	PCLXL	215	SDK3
160	MSIS		

7950	Replacement Date		
001	PCD		
	Displays the replacement date of the PCD.		
002	Transfer		
	Displays the replacement date of the transfer unit.		
003	Fuser		
	Displays the replacement date of the fusing unit.		
004	Web		
	Displays the replacement date of the web unit.		

7951	Remaining Counter		
001	PCD(Page)	[0 to 255 / <b>255</b> / 1 days]	
	Displays the remaining counter (pages) of the PCD.		
002	Transfer(Page)	[0 to 255 / <b>255</b> / 1 days]	
	Displays the remaining counter (pages) of the transfer unit.		
003	Fuser(Page)	[0 to 255 / <b>255</b> / 1 days]	
	Displays the remaining counter (pages) of the fusing unit.		

Service  
Tables

005	PCD(Rotation)	[0 to 255 / <b>255</b> / 1 days]
	Displays the remaining counter (rotations) of the PCD.	
006	Transfer(Rotation)	[0 to 255 / <b>255</b> / 1 days]
	Displays the remaining counter (rotations) of the transfer unit.	
007	Fuser(Rotation)	[0 to 255 / <b>255</b> / 1 days]
	Displays the remaining counter (rotations) of the fusing unit.	
009	PCD (%)	[0 to 255 / <b>100</b> / 1 %]
	Displays the remaining counter (%) of the PCD.	
010	Transfer (%)	[0 to 255 / <b>100</b> / 1 %]
	Displays the remaining counter (%) of the transfer unit.	
011	Fuser (%)	[0 to 255 / <b>100</b> / 1 %]
	Displays the remaining counter (%) of the fusing unit.	
013	Web (%)	[0 to 255 / <b>100</b> / 1 %]
	Displays the remaining counter (%) of the cleaning web.	

7952	PM Yield Setting	
	Sets the each yield of the following.	
⇒ 001	PCD(Page)	[0 to 99999999/ <b>160000</b> / 1 sheet]
	Sets the PM yield of the PCD (Pages).	
⇒ 002	Transfer(Page)	[0 to 99999999 / <b>160000</b> / 1 sheet]
	Sets the PM yield of the transfer unit (Pages).	
⇒ 003	Fuser(Page)	[0 to 99999999 / <b>160000</b> / 1 sheet]
	Sets the PM yield of the fusing unit (Pages).	
005	PCD(Rotation)	[0 to 999999999 / <b>75500000</b> / 1 mm]
	Sets the PM yield of the PCD (Rotations).	

006	Transfer(Rotation)	[0 to 999999999 / <b>65420000</b> / 1 mm]
	Sets the PM yield of the transfer unit (Rotations).	
007	Fuser(Rotation)	[0 to 999999999 / <b>52950000</b> / 1 mm]
	Sets the PM yield of the fusing unit (Rotations).	
009	Web (%)	[0 to 255 / <b>92</b> / 1 %]
	Sets the PM yield (%) of the web unit.	

7953	Operation Env Log	
001	T<10	[0 to 999999999 / <b>0</b> / 1 mm]
	Displays the PCU rotation distance in the environment: T<10°C	
002	10<=T<=17	[0 to 999999999 / <b>0</b> / 1 mm]
	Displays the PCU rotation distance in the environment: 10°C<=T<=17°C	
003	17<T<23	[0 to 999999999 / <b>0</b> / 1 mm]
	Displays the PCU rotation distance in the environment: 17<=T<=23	
004	23<=T<=27	[0 to 999999999 / <b>0</b> / 1 mm]
	Displays the PCU rotation distance of the environment: 23<=T<=27	
005	27<=T<=32	[0 to 999999999 / <b>0</b> / 1 mm]
	Displays the PCU rotation distance of the environment: 27<=T<=32	
006	32<T	[0 to 999999999 / <b>0</b> / 1 mm]
	Displays the PCU rotation distance of the environment: 32<T	

7954	Env Log Clear	
	Resets the environment logs (SP7953).	

Service  
Tables

## 5.11 ENGINE MAIN SP TABLES-8

### 5.11.1 SP8-XXX: DATA LOG2

Many of these counters are provided for features that are currently not available, such as sending color faxes, and so on. However, here are some Group 8 codes that when used in combination with others, can provide useful information.

SP Numbers	What They Do
SP8211 to SP8216	The number of pages scanned to the document server.
SP8401 to SP8406	The number of pages printed from the document server
SP8691 to SP8696	The number of pages sent from the document server

Specifically, the following questions can be answered:

- How is the document server actually being used?
- What application is using the document server most frequently?
- What data in the document server is being reused?

Most of the SPs in this group are prefixed with a letter that indicates the mode of operation (the mode of operation is referred to as an "application"). Before reading the Group 8 Service Table, make sure that you understand what these prefixes mean.

Prefixes	What it means	
T:	Total: (Grand Total).	Grand total of the items counted for all applications (C, F, P, etc.).
P:	Print application.	
O:	Other applications (external network applications, for example)	Refers to network applications such as Web Image Monitor. Utilities developed with the SDK (Software Development Kit) will also be counted with this group in the future.

The Group 8 SP codes are limited to 17 characters, forced by the necessity of displaying them on the small LCDs of printers and faxes that also use these SPs. Read over the list of abbreviations below and refer to it again if you see the name of an SP that you do not understand.

**Key for Abbreviations**

Abbreviation	What it means
/	"By", e.g. "T:Jobs/Apl" = Total Jobs "by" Application
>	More (2> "2 or more", 4> "4 or more")
AddBook	Address Book
Apl	Application
B/W	Black & White
Bk	Black
C	Cyan
ColCr	Color Create
ColMode	Color Mode
Comb	Combine
Comp	Compression
Deliv	Delivery
DesApl	Designated Application. The application (Copy, Fax, Scan, Print) used to store the job on the document server, for example.
Dev Counter	Development Count, no. of pages developed.
Dup, Duplex	Duplex, printing on both sides
Emul	Emulation
FC	Full Color
FIN	Post-print processing, i.e. finishing (punching, stapling, etc.)
Full Bleed	No Margins
GenCopy	Generation Copy Mode

Abbreviation	What it means
GPC	Get Print Counter. For jobs 10 pages or less, this counter does not count up. For jobs larger than 10 pages, this counter counts up by the number that is in excess of 10 (e.g., for an 11-page job, the counter counts up 11-10 =1)
IFax	Internet Fax
ImgEdt	Image Edit performed on the original with the copier GUI, e.g. border removal, adding stamps, page numbers, etc.
K	Black (YMCK)
LS	Local Storage. Refers to the document server.
LSize	Large (paper) Size
Mag	Magnification
MC	One color (monochrome)
NRS	New Remote Service, which allows a service center to monitor machines remotely. "NRS" is used overseas, "CSS" is used in Japan.
Org	Original for scanning
OrgJam	Original Jam
Palm 2	Print Job Manager/Desk Top Editor: A pair of utilities that allows print jobs to be distributed evenly among the printers on the network, and allows files to moved around, combined, and converted to different formats.
PC	Personal Computer
PGS	Pages. A page is the total scanned surface of the original. Duplex pages count as two pages, and A3 simplex count as two pages if the A3/DLT counter SP is switched ON.
PJob	Print Jobs
Ppr	Paper
PrtJam	Printer (plotter) Jam

Abbreviation	What it means
PrtPGS	Print Pages
R	Red (Toner Remaining). Applies to the wide format model A2 only. This machine is under development and currently not available.
Rez	Resolution
SC	Service Code (Error SC code displayed)
Scn	Scan
Sim, Simplex	Simplex, printing on 1 side.
S-to-Email	Scan-to-E-mail
SMC	SMC report printed with SP5990. All of the Group 8 counters are recorded in the SMC report.
Svr	Server
TonEnd	Toner End
TonSave	Toner Save
TXJob	Send, Transmission
YMC	Yellow, Magenta, Cyan
YMCK	Yellow, Magenta, Cyan, Black

Service Tables

**Note**

- All of the Group 8 SPs are able to reset by “SP5 801 1 Memory All Clear”.

8001	T:Total Jobs	*CTL	These SPs count the number of times each application is used to do a job. [0 to 99999999 / 0 / 1] <b>Note:</b> The L: counter is the total number of times the other applications are used to send a job to the document server, plus the number of times a file already on the document server is used.
8004	P:Total Jobs	*CTL	



- These SPs reveal the number of times an application is used, not the number of pages processed.
- When an application is opened for image input or output, this counts as one job.
- Interrupted jobs (paper jams, etc.) are counted, even though they do not finish.
- Only jobs executed by the customer are counted. Jobs executed by the customer engineer using the SP modes are not counted.
- When using secure printing (when a password is required to start the print job), the job is counted at the time when either "Delete Data" or "Specify Output" is specified.
- When the customer prints a report (user code list, for example), the O: counter increments.

8061	T:FIN Jobs	*CTL	[0 to 99999999 / 0 / 1]
	These SPs total the finishing methods. The finishing method is specified by the application.		
8064	P:FIN Jobs	*CTL	[0 to 99999999 / 0 / 1]
	These SPs total finishing methods for print jobs only. The finishing method is specified by the application.		
8067	O:FIN Jobs	*CTL	[0 to 99999999 / 0 / 1]
	These SPs total finishing methods for jobs executed by an external application, over the network. The finishing method is specified by the application.		
806x 1	Sort	Number of jobs started in Sort mode. When a stored copy job is set for Sort and then stored on the document server, the L: counter increments. (See SP8-066-1)	
806x 2	Stack	Number of jobs started out of Sort mode.	
806x 3	Staple	Number of jobs started in Staple mode.	
806x 4	Booklet	Number of jobs started in Booklet mode. If the machine is in staple mode, the Staple counter also increments.	
8 06x 5	Z-Fold	Number of jobs started In any mode other than the Booklet mode and set for folding (Z-fold).	

806x 6	Punch	Number of jobs started in Punch mode. When Punch is set for a print job, the P: counter increments. (See SP8-064-6.)
806x 7	Other	(Reserved)
806x 8	Inside-Flod	Not used
806x 9	Three-In-Fold	Not used
806x 10	Three-OUT-Fold	Not used
806x 11	Four-Fold	Not used
806x 12	KANNON-Fold	Not used
806x 13	Perfect-Bind	Not used
806x 14	Ring-Bind	Not used

8071	T:Jobs/PGS	*CTL	[0 to 99999999 / 0 / 1]
	These SPs count the number of jobs broken down by the number of pages in the job, regardless of which application was used.		
8074	P:Jobs/PGS	*CTL	[0 to 99999999 / 0 / 1]
	These SPs count and calculate the number of print jobs by size based on the number of pages in the job.		
8077	O:Jobs/PGS	*CTL	[0 to 99999999 / 0 / 1]
	These SPs count and calculate the number of "Other" application jobs (Web Image Monitor, Palm 2, etc.) by size based on the number of pages in the job.		
807x 1	1 Page	8 07x 8	21 to 50 Pages
807x 2	2 Pages	8 07x 9	51 to 100 Pages
807x 3	3 Pages	8 07x 10	101 to 300 Pages
807x 4	4 Pages	8 07x 11	301 to 500 Pages
807x 5	5 Pages	8 07x 12	501 to 700 Pages

Service  
Tables

Engine Main SP Tables-8

807x 6	6 to 10 Pages	8 07x 13	701 to 1000 Pages
807x 7	11 to 20 Pages	8 07x 14	1001 to Pages

- Interrupted jobs (paper jam, etc.) are counted, even though they do not finish.
- If a job is paused and re-started, it counts as one job.
- If the finisher runs out of staples during a print and staple job, then the job is counted at the time the error occurs.
- When printing the first page of a job from within the document server screen, the page is counted.

8381	T:Total PrtPGS	*CTL	<p>These SPs count the number of pages printed by the customer. The counter for the application used for storing the pages increments. [0 to 99999999 / 0 / 1]</p> <p>The L: counter counts the number of pages stored from within the document server mode screen at the operation panel. Pages stored with the Store File button from within the Copy mode screen go to the C: counter.</p>
8384	P:Total PrtPGS	*CTL	
8387	O:Total PrtPGS	*CTL	

- When the A3/DLT double count function is switched on with SP5104, 1 A3/DLT page is counted as 2.
- When several documents are merged for a print job, the number of pages stored are counted for the application that stored them.
- These counters are used primarily to calculate charges on use of the machine, so the following pages are not counted as printed pages:
  - Blank pages in a duplex printing job.
  - Blank pages inserted as document covers, chapter title sheets, and slip sheets.
  - Reports printed to confirm counts.
  - All reports done in the service mode (service summaries, engine maintenance reports, etc.)
  - Test prints for machine image adjustment.
  - Error notification reports.
  - Partially printed pages as the result of a copier jam.

8391	LSize PrtPGS	*CTL	[0 to 99999999 / 0 / 1]
	<p>These SPs count pages printed on paper sizes A3/DLT and larger.  <b>Note:</b> In addition to being displayed in the SMC Report, these counters are also displayed in the User Tools display on the copy machine.</p>		

8411	Prints/Duplex	*CTL	<p>This SP counts the amount of paper (front/back counted as 1 page) used for duplex printing. Last pages printed only on one side are not counted.                  [0 to 99999999 / 0 / 1]</p>
------	---------------	------	--

8421	T:PrtPGS/Dup Comb	*CTL	[0 to 99999999 / 0 / 1]
	<p>These SPs count by binding and combine, and n-Up settings the number of pages processed for printing. This is the total for all applications.</p>		

8424	P:PrtPGS/Dup Comb	*CTL	[0 to 99999999 / 0 / 1]
	<p>These SPs count by binding and combine, and n-Up settings the number of pages processed for printing by the printer application.</p>		

8427	O:PrtPGS/Dup Comb	*CTL	[0 to 99999999 / 0 / 1]
	<p>These SPs count by binding and combine, and n-Up settings the number of pages processed for printing by Other applications</p>		

842x 1	Simplex> Duplex		
842x 4	Simplex Combine		
842x 5	Duplex Combine		
842x 6	2in1		2 pages on 1 side (2-Up)
842x 7	4 in1		4 pages on 1 side (4-Up)
842x 8	6 in1		6 pages on 1 side (6-Up)
842x 9	8 in1		8 pages on 1 side (8-Up)
842x 10	9 in1		9 pages on 1 side (9-Up)
842x 11	16 in1		16 pages on 1 side (16-Up)



Engine Main SP Tables-8

842x 12	Booklet	
842x 13	Magazine	
842x 14	2-in-1 + Booklet	
842x 15	4-in-1 + Booklet	
842x 16	6-in-1 + Booklet	
842x 17	8-in-1 + Booklet	
842x 18	9-in-1 + Booklet	
842x 19	2-in-1 + Magazine	
842x 20	4-in-1 + Magazine	
842x 21	6-in-1 + Magazine	
842x 22	8-in-1 + Magazine	
842x 23	9-in-1 + Magazine	
842x 24	16-in-1 + Magazine	

- These counts (SP8 421 to SP8 427) are especially useful for customers who need to improve their compliance with ISO standards for the reduction of paper consumption.
- Pages that are only partially printed with the n-Up functions are counted as 1 page.
- Here is a summary of how the counters work for Booklet and Magazine modes:

Booklet		Magazine	
Original Pages	Count	Original Pages	Count
1	1	1	1
2	2	2	2
3	2	3	2
4	2	4	2
5	3	5	4
6	4	6	4
7	4	7	4
8	4	8	4

8431	T:PrtPGS/ImgEdt	*CTL	[0 to 99999999 / 0 / 1]
	These SPs count the total number of pages output with the three features below, regardless of which application was used.		
8434	P:PrtPGS/ImgEdt	*CTL	[0 to 99999999 / 0 / 1]
	These SPs count the total number of pages output with the three features below with the print application.		
8437	O:PrtPGS/ImgEdt	*CTL	[0 to 99999999 / 0 / 1]
	These SPs count the total number of pages output with the three features below with Other applications.		
843x 1	Cover/Slip Sheet	Total number of covers or slip sheets inserted. The count for a cover printed on both sides counts 2.	
843x 2	Series/Book	The number of pages printed in series (one side) or printed as a book with booklet right/left pagination.	

Service  
Tables

Engine Main SP Tables-8

843x 3	User Stamp	The number of pages printed where stamps were applied, including page numbering and date stamping.
--------	------------	--

8441	T:PrtPGS/Ppr Size	*CTL	[0 to 99999999 / 0 / 1]
	These SPs count by print paper size the number of pages printed by all applications.		
8444	P:PrtPGS/Ppr Size	*CTL	[0 to 99999999 / 0 / 1]
	These SPs count by print paper size the number of pages printed by the printer application.		
8447	O:PrtPGS/Ppr Size	*CTL	[0 to 99999999 / 0 / 1]
	These SPs count by print paper size the number of pages printed by Other applications.		
844x 1	A3		
844x 2	A4		
844x 3	A5		
844x 4	B4		
844x 5	B5		
844x 6	DLT		
844x 7	LG		
844x 8	LT		
844x 9	HLT		
844x 10	Full Bleed		
844x 254	Other (Standard)		
844x 255	Other (Custom)		

- These counters do not distinguish between LEF and SEF.

8451	PrtPGS/Ppr Tray		
	These SPs count the number of sheets fed from each paper feed station.		
001	Bypass Tray	*CTL	Bypass Tray [0 to 99999999 / 0 / 1]
002	Tray 1	*CTL	Copier [0 to 99999999 / 0 / 1]
003	Tray 2	*CTL	
004	Tray 3	*CTL	Paper Tray Unit (Option) [0 to 99999999 / 0 / 1]
005	Tray 4	*CTL	
006	Tray 5	*CTL	LCT (Option) [0 to 99999999 / 0 / 1]
007	Tray 6	*CTL	Currently not used.
008	Tray 7	*CTL	Currently not used.
009	Tray 8	*CTL	Currently not used.
010	Tray 9	*CTL	Currently not used.
011	Tray 10	*CTL	Currently not used.
012	Tray 11	*CTL	Currently not used.
013	Tray 12	*CTL	Currently not used.
014	Tray 13	*CTL	Currently not used.
015	Tray 14	*CTL	Currently not used.
016	Tray 15	*CTL	Currently not used.





8461	T:PrtPGS/Ppr Type	*CTL	[0 to 99999999 / 0 / 1]
	<p>These SPs count by paper type the number pages printed by all applications.</p> <ul style="list-style-type: none"> <li>▪ These counters are not the same as the PM counter. The PM counter is based on feed timing to accurately measure the service life of the feed rollers. However, these counts are based on output timing.</li> <li>▪ Blank sheets (covers, chapter covers, slip sheets) are also counted.</li> <li>▪ During duplex printing, pages printed on both sides count as 1, and a page printed on one side counts as 1.</li> </ul>		
8464	P:PrtPGS/Ppr Type	*CTL	[0 to 99999999 / 0 / 1]
	<p>These SPs count by paper type the number pages printed by the printer application.</p>		
846x 1	Normal		
846x 2	Recycled		
846x 3	Special		
846x 4	Thick		
846x 5	Normal (Back)		
846x 6	Thick (Back)		
846x 7	OHP		
846x 8	Other		

8471	PrtPGS/Mag		
	These SPs count by magnification rate the number of pages printed.		
001	< 49%	*CTL	[0 to 99999999 / 0 / 1]
002	50% to 99%	*CTL	
003	100%	*CTL	
004	101% to 200%	*CTL	
005	201% <	*CTL	

- Counts are done for magnification adjusted for pages, not only on the operation panel but performed remotely with an external network application capable of performing magnification adjustment as well.
- Magnification adjustments done with printer drivers with PC applications such as Excel are also counted.
- Magnification adjustments done for adjustments after they have been stored on the document server are not counted.
- Magnification adjustments performed automatically during Auto Reduce/Enlarge copying are counted.
- The magnification rates of blank cover sheets, slip sheets, etc. are automatically assigned a rate of 100%.

Service Tables

8481	T:PrtPGS/TonSave	*CTL	[0 to 99999999 / 0 / 1]
8484	P:PrtPGS/TonSave	*CTL	
<p>These SPs count the number of pages printed with the Toner Save feature switched on.</p> <p><b>Note:</b> These SPs return the same results as this SP is limited to the Print application.</p>			

8511	T:PrtPGS/Emul	*CTL	[0 to 99999999 / 0 / 1]	
	These SPs count by printer emulation mode the total number of pages printed.			
8514	P:PrtPGS/Emul	*CTL	[0 to 99999999 / 0 / 1]	
	These SPs count by printer emulation mode the total number of pages printed.			
8 51x 1	RPCS			
8 51x 2	RPDL			
8 51x 3	PS3			
8 51x 4	R98			
8 51x 5	R16			
8 51x 6	GL/GL2			
8 51x 7	R55			
8 51x 8	RTIFF			
8 51x 9	PDF			
8 51x 10	PCL5e/5c			
8 51x 11	PCL XL			
8 51x 12	IPDL-C			
8 51x 13	BM-Links			Japan Only
8 51x 14	Other			
8 51x 15	IPDS			

- SP8 511 and SP8 514 return the same results as they are both limited to the Print application.
- Print jobs output to the document server are not counted.

8521	T:PrtPGS/FIN	*CTL	[0 to 99999999 / 0 / 1]
	These SPs count by finishing mode the total number of pages printed by all applications.		
8524	P:PrtPGS/FIN	*CTL	[0 to 99999999 / 0 / 1]
	These SPs count by finishing mode the total number of pages printed by the Print application.		
8 52x 1	Sort		
8 52x 2	Stack		
8 52x 3	Staple		
8 52x 4	Booklet		
8 52x 5	Z-Fold		
8 52x 6	Punch		
8 52x 7	Other		
8 52x 8	Inside Fold	Half-Fold (FM2) (Multi Fold Unit)	
8 52x 9	Three-IN-Fold	Letter Fold-in (FM4) (Multi Fold Unit)	
8 52x 10	Three-OUT-Fold	Letter Fold-out (FM3) (Multi Fold Unit)	
8 52x 11	Four Fold	Double Parallel Fold (FM5) (Multi Fold Unit)	
8 52x 12	KANNON-Fold	Gate Fold (FM6) (Multi Fold Unit)	
8 52x 13	Perfect-Bind	Perfect Binder	
8 52x 14	Ring-Bind	Ring Binder	

Service Tables

**Note**

- If stapling is selected for finishing and the stack is too large for stapling, the unstapled pages are still counted.
- The counts for staple finishing are based on output to the staple tray, so jam recoveries are counted.

Engine Main SP Tables-8

8531	Staples	*CTL	This SP counts the amount of staples used by the machine. [0 to 99999999 / 0 / 1]
------	---------	------	--

8551	T:FIN Books		
001	Perfect-Bind	*CTL	Not used
002	Ring-Bind	*CTL	

8554	T:FIN Books		
001	Perfect-Bind	*CTL	Not used
002	Ring-Bind	*CTL	

8561	T:A Sheet Of Paper		
001	Total: Over A3/DLT	*CTL	[0 to 999999999 / 0 / 1]
002	Total: Under A3/DLT	*CTL	
003	Duplex: Over A3/DLT	*CTL	
004	Duplex: Under A3/DLT	*CTL	

8564	P:A Sheet Of Paper		
001	Total: Over A3/DLT	*CTL	[0 to 999999999 / 0 / 1]
002	Total: Under A3/DLT	*CTL	
003	Duplex: Over A3/DLT	*CTL	
004	Duplex: Under A3/DLT	*CTL	

8567	O:A Sheet Of Paper		
001	Total: Over A3/DLT	*CTL	[0 to 99999999 / 0 / 1]
002	Total: Under A3/DLT	*CTL	
003	Duplex: Over A3/DLT	*CTL	
004	Duplex: Under A3/DLT	*CTL	

8581	T:Counter		
	These SPs count the total output broken down by color output, regardless of the application used. In addition to being displayed in the SMC Report, these counters are also displayed in the User Tools display on the copy machine.		
001	Total	*CTL	[0 to 99999999 / 0 / 1]

8591	O:Counter		
	These SPs count the totals for A3/DLT paper use, number of duplex pages printed, and the number of staples used. These totals are for Other (O:) applications only.		
001	A3/DLT	*CTL	[0 to 99999999 / 0 / 1]
002	Duplex	*CTL	

8601	T: Coverage Counter		
	These SPs count the total coverage for each color and the total printout pages for each printing mode.		
001	B/W	*CTL	[0 to 2147483647 / 0 / 1% /step]
011	B/W Printing Pages	*CTL	[0 to 99999999 / 0 / 1]

Service Tables

Engine Main SP Tables-8

8604	P:Coverage Counter		
	-		
001	B/W	*CTL	[0 to 2147483647 / 0 / 1% /step]

8617	SDK Apli Counter		
	These SPs count the total printout pages for each SDK application.		
001	SDK-1	*CTL	[0 to 99999999 / 0 / 1]
002	SDK-2	*CTL	
003	SDK-3	*CTL	
004	SDK-4	*CTL	
005	SDK-5	*CTL	
006	SDK-6	*CTL	

8621	Func Use Counter		
	-		
001	Function-001	*CTL	[0 to 99999999 / 0 / 1]
002	Function-002	*CTL	
003	Function-003	*CTL	
004	Function-004	*CTL	
005	Function-005	*CTL	
006	Function-006	*CTL	
007	Function-007	*CTL	
008	Function-008	*CTL	
009	Function-009	*CTL	
010	Function-010	*CTL	

011	Function-011	*CTL	[0 to 99999999 / 0 / 1]
012	Function-012	*CTL	
013	Function-013	*CTL	
014	Function-014	*CTL	
015	Function-015	*CTL	
016	Function-016	*CTL	
017	Function-017	*CTL	
018	Function-018	*CTL	
019	Function-019	*CTL	
020	Function-020	*CTL	
021	Function-021	*CTL	[0 to 99999999 / 0 / 1]
022	Function-022	*CTL	
023	Function-023	*CTL	
024	Function-024	*CTL	
025	Function-025	*CTL	
026	Function-026	*CTL	
027	Function-027	*CTL	
028	Function-028	*CTL	
029	Function-029	*CTL	
030	Function-030	*CTL	
031	Function-031	*CTL	[0 to 99999999 / 0 / 1]
032	Function-032	*CTL	
033	Function-033	*CTL	
034	Function-034	*CTL	
035	Function-035	*CTL	





Engine Main SP Tables-8

036	Function-036	*CTL	
037	Function-037	*CTL	
038	Function-038	*CTL	
039	Function-039	*CTL	
040	Function-040	*CTL	
041	Function-041	*CTL	[0 to 99999999 / 0 / 1]
042	Function-042	*CTL	
043	Function-043	*CTL	
044	Function-044	*CTL	
045	Function-045	*CTL	
046	Function-046	*CTL	
047	Function-047	*CTL	
048	Function-048	*CTL	
049	Function-049	*CTL	
050	Function-050	*CTL	
051	Function-051	*CTL	[0 to 99999999 / 0 / 1]
052	Function-052	*CTL	
053	Function-053	*CTL	
054	Function-054	*CTL	
055	Function-055	*CTL	
056	Function-056	*CTL	
057	Function-057	*CTL	
058	Function-058	*CTL	
059	Function-059	*CTL	
060	Function-060	*CTL	

061	Function-061	*CTL	[0 to 99999999 / 0 / 1]
062	Function-062	*CTL	
063	Function-063	*CTL	
064	Function-064	*CTL	

8771	Dev Counter		
	These SPs count the frequency of use (number of rotations of the development rollers) for black and other color toners.		
001	Total	*CTL	[0 to 99999999 / 0 / 1]

8781	Toner_Bottle_Info.	*ENG	[0 to 9999999 / 0 / 1]
	These SPs display the number of already replaced toner bottles. <b>NOTE:</b> Currently, the data in SP7-833-011 through 014 and the data in SP8-781-001 through 004 are the same.		
001	Toner: BK	The number of black-toner bottles	

8801	Toner Remain		
	These SPs display the percent of toner remaining for each color. This SP allows the user to check the toner supply at any time. <b>Note:</b> This precise method of measuring remaining toner supply (1% steps) is better than other machines in the market that can only measure in increments of 10 (10% steps).		
001	K	*CTL	[0 to 100 / 0 / 1% /step]

Service Tables

Engine Main SP Tables-8

8811	Eco Counter		
	-		
001	Eco Total	*CTL	[0 to 99999999 / 0 / 1]
004	Duplex	*CTL	
005	Combine	*CTL	
008	Duplex (%)	*CTL	
009	Combine (%)	*CTL	
010	Paper Cut (%)	*CTL	
101	Eco Totalr>Last	*CTL	[0 to 99999999 / 0 / 1]
104	Duplex>Last	*CTL	
105	Combine>Last	*CTL	
108	Duplex (%):Last	*CTL	[0 to 100 / 0 / 1% /step]
109	Combine (%):Last	*CTL	
110	Paper Cut (%):Last	*CTL	

8851	Cvr Cnt: 0-10%		
	These SPs display the number of scanned sheets on which the coverage of each color is from 0% to 10%.		
011	0 to 2%: BK	*ENG	[0 to 99999999 / 0 / 1]
021	3 to 4%: BK	*ENG	[0 to 99999999 / 0 / 1]
031	5 to 7%: BK	*ENG	[0 to 99999999 / 0 / 1]
041	8 to 10%: BK	*ENG	[0 to 99999999 / 0 / 1]

8861	CVr Cnt: 11-20%		
	These SPs display the number of scanned sheets on which the coverage of each color is from 11% to 20%.		
001	BK	*ENG	[0 to 99999999 / 0 / 1]

8871	CVr Cnt: 21-30%		
	These SPs display the number of scanned sheets on which the coverage of each color is from 21% to 30%.		
001	BK	*ENG	[0 to 99999999 / 0 / 1]

8881	CVr Cnt: 31%-		
	These SPs display the number of scanned sheets on which the coverage of each color is 31% or higher.		
001	BK	*ENG	[0 to 99999999 / 0 / 1]

8891	Page/Toner Bottle		
	These SPs display the amount of the remaining current toner for each color.		
001	BK	*ENG	[0 to 99999999 / 0 / 1]

8901	Page/Toner_prev1		
	These SPs display the amount of the remaining previous toner for each color.		
001	BK	*ENG	[0 to 99999999 / 0 / 1]

Service  
Tables

Engine Main SP Tables-8

8911	Page/Toner_prev2		
	These SPs display the amount of the remaining 2nd previous toner for each color.		
001	BK	*ENG	[0 to 99999999 / 0 / 1]

8921	Cvr Cnt/Total		
	Displays the total coverage and total printout number for each color.		
001	Coverage (%) Bk	*CTL	[0 to 2147483647 / 0 / 1% /step]
011	Coverage /P: Bk	*CTL	[0 to 99999999 / 0 / 1]

8941	Machine Status	*CTL	[0 to 99999999 / 0 / 1]
	These SPs count the amount of time the machine spends in each operation mode. These SPs are useful for customers who need to investigate machine operation for improvement in their compliance with ISO Standards.		
001	Operation Time	Engine operation time. Does not include time while controller is saving data to HDD (while engine is not operating).	
002	Standby Time	Engine not operating. Includes time while controller saves data to HDD. Does not include time spent in Energy Save, Low Power, or Off modes.	
003	Energy Save Time	Includes time while the machine is performing background printing.	
004	Low Power Time	Includes time in Energy Save mode with Engine on. Includes time while machine is performing background printing.	
005	Off Mode Time	Includes time while machine is performing background printing. Does not include time machine remains powered off with the power switches.	

006	SC	Total time when SC errors have been staying.
007	PrtJam	Total time when paper jams have been staying during printing.
008	OrgJam	Total time when original jams have been staying during scanning.
009	Supply PM Unit End	Total time when toner end has been staying

8961	Electricity Status		
	-		
001	Ctrl Standby Time	*CTL	[0 to 99999999 / 0 / 1]
002	STR Time	*CTL	
003	Main Power Off Time	*CTL	
004	Reading and Printing Time	*CTL	
005	Printing Time	*CTL	[0 to 99999999 / 0 / 1]
006	Reading Time	*CTL	
007	Eng Waiting Time	*CTL	
008	Low Power State Time	*CTL	
009	Silent State Time	*CTL	



Engine Main SP Tables-8

8999	Admin. Counter List		
	-		
001	Total		[0 to 999999999 / 0 / 1]
007	Printer: BW		
012	A3/DLT		
013	Duplex		
027	Printer: BW(%)		[0 to 2147483647 / 0 / 1]

## 5.12 ENGINE MAIN SP TABLES-9

### 5.12.1 INPUT CHECK TABLE

#### *Copier*

When entering the Input Check mode, 8 digits display the result for a section. Each digit corresponds to a different device as shown in the table.

Bit No.	7	6	5	4	3	2	1	0
<b>Result</b>	0 or 1	0 or 1	0 or 1	0 or 1	0 or 1	0 or 1	0 or 1	0 or 1

5803	Input Check		
	Description	Reading	
		0	1
001	Tray 1: Paper Size Sensor	See the table 1 following this table.	
002	Tray 1: Tray Set Sensor	Set	Not set
003	Tray 1: Paper Lift Sensor	Not upper limit	Upper limit
004	Tray 1: Paper End Sensor	No paper	Paper remaining
005	Tray 1: Paper Height Sensor 1	See the table 2 following this table.	
006	Tray 1: Paper Height Sensor 2		
007	Tray 2: Paper Size Sensor	See the table 1 following this table.	
008	Tray 2: Tray Set Sensor	Set	Not set
009	Tray 2: Paper Lift Sensor	Not upper limit	Upper limit
010	Tray 2: Paper End Sensor	No paper	Paper remaining
011	Tray 2: Paper Height Sensor 1	See the table 2 following this table.	



012	Tray 2: Paper Height Sensor 2		
013	Tray 1: Paper Feed Sensor	Paper detected	No paper detected
014	Tray 2: Paper Feed Sensor	Paper detected	No paper detected
015	Tray 3: Paper Feed Sensor	Paper detected	No paper detected
016	Tray 4: Paper Feed Sensor	Paper detected	No paper detected
017	LCT: Paper Feed Sensor	No paper detected	Paper detected
018	Relay Sensor 1	Paper detected	No paper detected
019	Relay Sensor 2	Paper detected	No paper detected
020	Relay Sensor 3	No paper detected	Paper detected
021	Relay Sensor 4	No paper detected	Paper detected
022	Relay Sensor: LCT	No paper detected	Paper detected
023	By-pass: Paper End Sensor	Not end	Paper end
024	By-pass: Paper Size Sensor	See the table 3 following this table.	
025	Registration Sensor	Paper detected	No paper detected
026	Fusing Exit Sensor	No paper detected	Paper detected
027	Fusing Entrance Sensor	Paper detected	No paper detected
028	Junction Gate Relay Sensor	Paper detected	No paper detected
029	Exit Sensor	Paper detected	No paper detected
030	Paper Overflow Sensor	Not full	Full
031	Right Cover Open/Close	Close	Open
032	Duplex Unit Open/Close	Open	Close
033	Duplex Entrance Sensor	Paper detected	No paper detected
034	Duplex Exit Sensor	Paper detected	No paper detected
035	Bank Right Cover Open/Close	Close	Open

036	Tray Cover Open/Close	Close	Open
037	LCT Set	Set	Not set
038	Bridge Tray: Exit Sensor	Paper detected	No paper detected
039	Bridge Tray: Relay Sensor	Paper detected	No paper detected
040	Bridge Tray: Set Detection	Set	Not set
041	Bridge Tray: Left Guide Open/Close	Close	Open
042	Bridge Tray: Right Guide Open/Close	Close	Open
043	Transfer Belt Unit HP Sensor	Not HP	HP
044	New U. Det: Trans.	New	Not new
045	New U. Det: Fusing.	New	Not new
046	Fusing Unit Set	Set (Bit1)	Not set (Bit1)
047	Toner Overflow Sensor	Not full	Full
048	Interlock Detection 1	Right or front door is open.	Right or front door is close.
049	Interlock Detection 2	Right or front door is open.	Right or front door is close.
055	New U. Det. :PCDU	New	Not new
057	Cleaning Web End	Not end	End
058	Punch Switch	On	Off
065	Bypass Tray Paper Length Detection	Paper detected	No paper detected
200	Scanner HP Sensor	Not HP	HP
201	Platen Cover Sensor	Open	Close

**Table 1: Paper Height Sensor**

0: Deactivated, 1: Activated (actuator inside sensor)

Remaining paper	Paper height sensor 1	Paper height sensor 2
Full	0	0
Nearly full	1	0
Near end	1	1
Almost empty	0	1

**Table 2: Paper Size Switch**

Switch 1 is used for the tray set detection.

0: Pushed, 1: Not pushed

Models		Switch Location		
North America	Europe/Asia	4	3	2
11" x 17" SEF*1 (A3 SEF)	A3 SEF*1 (11" x 17" SEF)	0	0	1
8.5" x 14" SEF *2 (B4 SEF)	B4 SEF *2 (8.5" x 14" SEF)	0	0	0
A4 SEF	A4 SEF	1	1	0
8.5" x 11" SEF	8.5" x 11" SEF	1	1	1
B5 SEF	B5 SEF	0	1	1
11" x 8 1/2" LEF*3 (A4 LEF)	A4 LEF*3 (11" x 8 1/2" LEF)	1	0	0
10.5" x 7.25" LEF*4 (B5 LEF)	B5 LEF*4 (10.5" x 7.25" LEF)	0	1	0
A5 LEF	A5 LEF	1	0	1

Models		Switch Location		
North America	Europe/Asia	4	3	2
<p>*1: The machine detects either 11" x 17" SEF or A3 SEF, depending on the setting of SP 5-181-002 (Tray 1) or -006 (Tray 2).</p> <p>*2: The machine detects either 8.5" x 14" SEF or B4 SEF, depending on the setting of SP 5-181-003 (Tray 1) or -007 (Tray 2).</p> <p>*3: The machine detects either 11" x 8 1/2" LEF or A4 LEF, depending on the setting of SP 5-181-001 (Tray 1) or -005 (Tray 2).</p> <p>*4: The machine detects either B5 LEF or 10.5" x 7.25" LEF, depending on the setting of SP 5-181-004 (Tray 1) or -008 (Tray 2)..</p>				

**Table 3: Paper Size (By-pass Table)**

0: Pushed, 1: Not pushed

Models		Bit No.			
North America	Europe/Asia	3	2	1	0
11" x 17" SEF*1 (11" x 8.5" LEF)	A3 SEF*1 (A4 LEF)	1	1	1	0
11" x 17" SEF*1 (11" x 8.5" LEF)	A3 SEF*1 (A4 LEF)	1	1	0	0
8.5" x 11" SEF*1 (8.5" x 11" SEF*2)	A4 SEF*1 (A5 LEF)	1	1	0	1
8.5" x 11" SEF*1 (8.5" x 11" SEF*2)	A4 SEF*1 (B5 LEF)	1	0	0	1
5.5" x 8.5" SEF	A5 SEF	1	0	1	1
5.5" x 8.5" SEF	A5 SEF	0	0	1	1
5.5" x 8.5" SEF	A6 SEF	0	1	1	1
5.5" x 8.5" SEF	A6 SEF	1	1	1	1

 **Note**

Service Tables

- \*1: When the machine determines that the paper feed direction is "LEF", it considers that the paper size is bracketed size.

**APS Original Size Detection**

Original Size		Length Sensor			Width Sensor		SP4-301 display
Metric version	Inch version	L3	L2	L1	W1	W2	
A3	11" x 17"	O	O	O	O	O	00011111
B4	10" x 14"	O	O	O	O	X	00011110
F4 8.5" x 13", 8.25" x 13", or 8" x 13" SP 5126 controls the size that is detected	8.5" x 14"	O	O	O	X	X	00011100
A4 LEF	8.5" x 11"	X	X	X	O	O	00000011
B5 LEF	-	X	X	X	O	X	00000010
A4 SEF	11" x 8.5"	X	O	O	X	X	00001100
B5 SEF	-	X	X	O	X	X	00000100
A5 LEF/ SEF	5.5" x 8.5", 8.5" x 5.5"	X	X	X	X	X	00000000

**3000-Sheet Finisher (D636)**

6140	Bit	Description	Reading	
			0	1
001		Entrance Sensor	No paper detected	Paper detected
002		Proof Exit Sensor	No paper detected	Paper detected
003		Proof Full Detection Sensor	Not Full	Full
004		Upper Tray Exit Sensor	No paper detected*1	Paper detected*1
005		Staple Exit Sensor	No paper detected	Paper detected
006		Shift Roller HP Sensor	Not HP	HP
007		Shift Exit Sensor	No paper detected	Paper detected
008		Exit Guide Plate HP Sensor	Not HP	HP
009		Lower Tray Height Sensor	No paper detected	Paper detected
010		Upper Tray Height Sensor	No paper detected	Paper detected
011		Upper Tray Full Sensor	Not Full	Full
012		Stack Roller HP Sensor	Not HP	HP
013		Jogger HP Sensor	Not HP	HP
014		Feed Out Belt HP Sensor	HP	Not HP
015		Stapling Tray Paper Sensor	No paper detected	Paper detected
016		Corner Stapler HP Sensor	Not HP	HP
017		Stapler Rotation HP Sensor	Not HP	HP
018		Upper Tray Limit SW	Not Limit	Limit
019		Door Switch	Closed	Open
020		Corner Stapler Operation	Not HP	HP

Engine Main SP Tables-9

6140	Bit	Description	Reading	
			0	1
021		Staple Detection	No staple detected	Staple detected
022		Staple Dip Detection	No staple detected	Staple detected
023		Punch Movement HP Sensor	Not HP	HP
024		Paper Position Slide HP Sensor	Not HP	HP
025		Paper Position Sensor	No paper detected	Paper detected
026		Punch Full Sensor	Not Full	Full
027		Punch HP Sensor	Not HP	HP
028		Punch DIP SW 1	See *1	
029		Punch DIP SW 2	See *1	
030		Stack Junction Gate HP Sensor	Not HP	HP
031		Stack Present Sensor	No paper detected	Paper detected
032		Clamp Roller HP Sensor	Not HP	HP
033		Fold Entrance Sensor	No paper detected	Paper detected
034		Bottom Fence HP Sensor	Not HP	HP
035		Fold Cam HP Sensor	Not HP	HP
036		Fold Plate HP Sensor	Not HP	HP
037		Fold Unit Exit Sensor	No paper detected	Paper detected
038		Lower Tray Full Sensor: Front	No paper detected	Paper detected
039		Lower Tray Full Sensor: Rear	No paper detected	Paper detected
040		Booklet Stapler 1: Operation	Not HP	HP
041		Booklet Stapler 1: Staple In (Front)	No staple detected	Staple detected
042		Booklet Stapler 1: Staple In (Leading Edge)	No staple detected	Staple detected

6140	Bit	Description	Reading	
			0	1
043		Booklet Stapler 1: Operation (Rotation/Rear)	Not HP	HP
044		Booklet Stapler 1: Staple In (Rear)	No staple detected	Staple detected
045		Booklet Stapler 1: Staple In (Leading Edge/Rear)	No staple detected	Staple detected
046		Upper Tray Full Sensor: 3000	Not Full	Full
047		Exit Jogger HP Sensor: Front	Not HP	HP
048		Exit Jogger HP Sensor: Rear	Not HP	HP
049		Exit Jogger HP Sensor: Upper	Not HP	HP

\*1: Combination of DIP SW 1 and SW 2

DIP SW 1	DIP SW 2	Punch Type
0	0	Japan
1	0	Europe
0	1	North America
1	1	North Europe





**1000-Sheet Finisher (D588)**

6139	Bit	Description	Reading	
			0	1
001		Entrance Sensor	Paper detected	No paper detected
002		Shift Exit Sensor (Lower Tray Exit Sensor)	No paper detected	Paper detected
003		Staple Entrance Sensor (Stapler Tray Entrance Sensor)	Paper detected	No paper detected
004		Staple Moving HP Sensor (Stapler HP Sensor)	Not HP	HP
005		Jogger HP Sensor (Jogger Fence HP Sensor)	Not HP	HP
006		Stack Feed-out Belt HP Sensor	HP	Not HP
007		Staple Tray Paper Sensor	No paper detected	Paper detected
008		Staple Rotation Sensor (Staple Rotation HP Sensor)	Not HP	HP
009		Staple Sensor	Staple detected	No staple detected
010		Staple READY Detection	Staple detected	No staple detected
011		Exit Guide Plate HP (Exit Guide Plate HP Sensor)	Not HP	HP
012		Shift HP Sensor	Not HP	HP
013		Paper Sensor (Stack Height Sensor)	No output tray detected	Output tray detected
014		Tray Lower Sensor (Lower Tray Lower Limit Sensor)	Lower limit	Not lower limit

6139	Bit	Description	Reading	
			0	1
015		Proof Full Sensor (Paper Limit Sensor)	Not full	Full

### 5.12.2 OUTPUT CHECK TABLE

**Copier**

5804	Output Check	
001	Exit Motor: 350	Paper exit motor (Mainframe)
002	Exit Motor: 175	
003	Exit Motor: 230	
004	Exit Motor: 180	
005	Exit Motor: 154	
006	Exit Motor: 90	
007	Feed Motor: 300	Paper feed motor (Mainframe)
008	Feed Motor: 255	
009	Feed Motor: 230	
010	Feed Motor: 215	
011	Feed Motor: 180	
012	Feed Motor: 154	
013	Feed Motor: 90	Paper feed motor (Optional paper feed unit)
014	Bank: Feed Motor: 300	
015	Bank: Feed Motor: 255	
016	Bank: Feed Motor: 230	

Service Tables

Engine Main SP Tables-9

5804	Output Check	
017	Bank: Feed Motor: 215	
018	Bank: Feed Motor: 180	
019	Bank: Feed Motor: 154	
020	Bank: Feed Motor: 90	
021	LCT: Feed Motor: 300	Paper feed motor (Optional LCT)
022	LCT: Feed Motor: 255	
023	LCT: Feed Motor: 230	
024	LCT: Feed Motor: 215	
025	LCT: Feed Motor: 180	
026	LCT: Feed Motor: 154	
027	LCT: Feed Motor: 90	
028	Paper Feed Clutch 1	Paper feed clutch 1/2 (Mainframe)
029	Paper Feed Clutch 2	
030	Bank: Paper Feed Clutch 3	Paper feed clutch 3/4 (Optional paper feed unit)
031	Bank: Paper Feed Clutch 4	
032	LCT: Paper Feed Clutch	Paper feed clutch (Optional LCT)
033	Pick-up Solenoid 1	Pick-up Solenoid 1/2 (Mainframe)
034	Pick-up Solenoid 2	
035	Bank: Pick-up Solenoid 3	Pick-up Solenoid 3/4 (Optional paper feed unit)
036	Bank: Pick-up Solenoid 4	
037	LCT: Pick-up Solenoid	Pick-up Solenoid (LCT)
038	Tray Lift Motor 1: Up	-
039	Tray Lift Motor 1: Down	
040	Tray Lift Motor 2: Up	

5804	Output Check	
041	Tray Lift Motor 2: Down	
042	Paper Tray Lock Solenoid	Not used
043	Bank: Paper Tray Lock Solenoid	Tray lock solenoid (Optional paper feed unit)
044	Registration Motor: 230	-
045	Registration Motor: 180	
046	Registration Motor: 154	
047	Registration Motor: 90	
048	Exit: Junction Gate Solenoid	Junction gate 1 solenoid
049	Duplex: Inverter Gate Solenoid	Not used
050	Duplex Inverter Motor: Fwd: 230	-
051	Duplex Inverter Motor: Fwd: 180	
052	Duplex Inverter Motor: Fwd: 154	
053	Duplex Inverter Motor: Fwd: 90	
054	Duplex Inverter Motor: Rev: 230	
055	Duplex Inverter Motor: Rev: 180	
056	Duplex Inverter Motor: Rev: 154	
057	Duplex Inverter Motor: Rev: 90	
058	Duplex/By-pass Motor: Fwd: 230	-
059	Duplex/By-pass Motor: Fwd: 180	
060	Duplex/By-pass Motor: Fwd: 154	
061	Duplex/By-pass Motor: Fwd: 90	
062	Duplex/By-pass Motor: Rev: 230	
063	Duplex/By-pass Motor: Rev: 180	

Service  
Tables

Engine Main SP Tables-9

5804	Output Check	
064	Duplex/By-pass Motor: Rev: 154	
065	Duplex/By-pass Motor: Rev: 90	
066	By-pass Feed Clutch	-
067	By-pass Pick-up Solenoid	-
068	Bridge Tray: Drive Motor: 230	Drive motor (Bridge unit)
069	Bridge Tray: Drive Motor: 180	
070	Bridge Tray: Drive Motor: 154	
071	Bridge Tray: Drive Motor: 90	
072	Bridge Tray: Junction Gate Solenoid	Junction Gate Solenoid (Bridge unit)
073	Bridge Tray: Drive Motor: Reset	-
074	Bridge Tray: Drive Motor: Enable	-
075	Bridge: Cooling Fan Motor	Not used
076	Transfer Belt Contact Motor	-
077	OPC Motor: 230	Drum motor
078	OPC Motor: 180	
079	OPC Motor: 154	
080	OPC Motor: 90	
081	Transfer/Development Motor: 230	-
082	Transfer/Development Motor: 180	
083	Transfer/Development Motor: 154	
084	Transfer/Development Motor: 90	
085	Fusing Motor: 230	-
086	Fusing Motor: 180	

5804	Output Check	
087	Fusing Motor: 154	
088	Fusing Motor: 90	
089	Development Puddle Motor	-
090	PTL Control	-
091	Fusing Fan Motor: High	Fusing exhaust fan motor
092	Fusing Fan Motor: Low	
093	Exhaust Fan Motor: High	Exhaust fan motor
094	Exhaust Fan Motor: Low	
095	Duct Fan Motor	Cooling fan motor
096	Exit Fan Motor: High	Paper exit cooling fan motor
097	Exit Fan Motor: Low	
098	PSU Fan Motor	-
100	Polygon Motor: 230	
101	Polygon Motor: 180	
102	Polygon Motor: 154	
103	Polygon Motor: 90	
104	LD 1	-
105	LD 2	
106	Toner Bottle Motor: Fwd	Toner supply motor
107	Quenching Lamp	-
108	Charge Bias	-
109	Development Bias	-
110	Transfer Belt Voltage	-
111	ID Sensor LED	-

Service  
Tables

5804	Output Check	
112	Attention light: Buzzer	-
113	Attention light: Blue lamp	-
114	Attention light: Red lamp	-
115	Cleaning Web Motor	Web motor
117	CTL Cooling FAN	Controller fan

**1000-Sheet Finisher (D588)**

6144	Output Check	
	Display	Description
001	Upper Relay Motor	Upper Transport Motor
002	Lower Relay Motor	Lower Transport Motor
003	Exit Motor	-
004	Proof Junction Gate SOL	Tray Junction Gate Solenoid
005	Lower Tray Lift Motor	-
006	Jogger Fence Motor	-
007	Stapler Motor	-
008	Stapler Hammer	-
009	Stapler Junction Gate Solenoid	-
010	Positioning Roller Solenoid	-
011	Stack Feed-out Motor	-
012	Shift Motor	-
013	Exit Guide Plate Motor	-

### 5.12.3 3000-SHEET FINISHER (D636)

6145	Output	
	Display	Description
001	Entrance Motor	-
002	Upper Transport Motor	-
003	Lower Transport Motor	-
004	Upper/Proof Tray Exit Motor	-
005	Clamp Roller Retraction Motor	-
006	Shift Roller Motor	-
007	Exit Guide Plate Motor	-
008	Upper Tray Lift Motor	-
009	Stacking Sponge Roller Motor	-
010	Jogger Fence Motor	-
011	Feed Out Belt Motor	-
012	Corner Stapler Movement Motor	-
013	Corner Stapler Rotation Motor	-
014	Corner Stapler	-
015	Proof Junction Gate Solenoid	-
016	Stapling Tray Junction Gate Solenoid	-
017	Stapling Edge Pressure Plate Solenoid	-
018	Positioning Roller Solenoid	-
019	Booklet Pressure Roller Solenoid	-
020	Stack Junction Gate Motor	-
021	Fold Unit Bottom Fence Lift Motor	-



Engine Main SP Tables-9

022	Booklet Stapler: Front	-
023	Booklet Stapler: Rear	-
024	Fold Plate Motor	-
025	Fold Roller Motor	-
026	Positioning Roller Motor	-
027	Punch Drive Motor	-
028	Punch Movement Motor	-
029	Paper Position Sensor Slide Motor	-
030	Exit Jogger Motor: Front	-
031	Exit Jogger Motor: Rear	-
032	Exit Jogger Motor Release Motor	-

## 5.13 UPDATING THE FIRMWARE

To update the firmware for this machine, you must have the new version of the firmware downloaded onto an SD (Secure Digital) Card. The SD Card is inserted into SD Card Slot 2 (Lower Slot) on the controller box.

### 5.13.1 BEFORE YOU BEGIN

An SD card is a precision device. Always observe the following precautions when you handle SD cards:

- Always switch the machine off before you insert an SD card. Never insert the SD card into the slot with the power on.
- Do not remove the SD card from the service slot after the power has been switched on.
- Never switch the machine off while the firmware is downloading from the SD card.
- Keep SD cards in a safe location where they are not exposed to high temperature, high humidity, or exposure to direct sunlight.
- Always handle SD cards with care. Do not bend or scratch them. Do not let the SD card get exposed to shock or vibration.
- Make sure that the write protection of an SD card is unlocked when you download an application to it. If not, downloading fails and a download error (e.g. Error Code 44) occurs during a firmware upgrade.

Keep the following points in mind when you use the firmware update software:

- "Upload" means to send data from the machine to the SD card. "Download" means to send data from the SD card to the machine.
- To select an item on the LCD, touch the appropriate button on the soft touch-screen of the LCD.
- Disconnect the Ethernet interface cable, Gigabit Ethernet cable, IEEE1284 interface cable and remove the Wireless LAN interface board before you start the firmware update procedure. Make sure that the machine is disconnected from the network to prevent a print job for arriving while the firmware update is in progress.

## 5.13.2 UPDATING FIRMWARE

### Preparation

1. If the SD card is blank, copy the entire "romdata" folder onto the SD card.
2. If the card already contains the "romdata" folder, copy the "M132" folder onto the card.

### Updating Procedure

1. Turn the main power switch off.



2. Remove the SD card slot cover [A] (⚙ x 1).

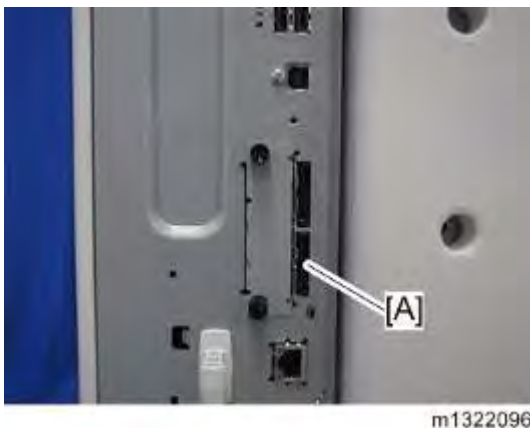

3. Insert the SD card into SD Card Slot 2 (Lower Slot) [A]. Make sure the label on the SD card faces the rear side of the machine.
4. Slowly push the SD card into the slot so it locks in place. You will hear it click. Make sure the SD card locks in place.

#### ⚠ Note

- To remove the SD, push it in to unlock the spring lock. Then release it so it pops out of the slot.
5. Disconnect the network cable from the machine if the machine is connected to a network.
  6. Switch the main power switch on. After about 45 seconds, the initial version update screen appears on the LCD in English.

7. On the screen, touch the button on the operation panel to select the item in the menu that you want to update.

ROM/NEW	What it means
ROM:	Tells you the number of the module and name of the version currently installed. The first line is the module number, the second line the version name.
NEW:	Tells you the number of the module and name version on the SD card. The first line is the module number, the second line the version name.

**Note**

- Controller, engine and operation panel firmware cannot be updated at the same time. It is recommended to update firmware modules one by one.

8. Touch "UpDate (#)" to start the update.

**Note**

- While downloading is in progress, the LCD will display "Loading". When downloading has been completed, the panel will display "update done".
- For operation panel software, the Data In indicator flashes red while downloading is in progress, and then the Check Status indicator flashes green after downloading is completed.

9. The "Update done." message appears on the operation panel after completing the updating. The message differs depending on the firmware that has been updated.
10. Switch the main power switch off when you see the "Update done" message or follow the procedure that is displayed on the operation panel.
11. Press in the SD card to release it. Then remove it from the slot.
12. Switch the main power switch on for normal operation.

### **Error Messages**

An error message shows in the first line if an error occurs during the download.

The error code consists of the letter "E" and a number. The example above shows error "E24" displayed. For details, refer to the Error Message Table. (👉 "Handling Firmware Update Errors" in this section)

### ***Firmware Update Error***

If a firmware update error occurs, this means the update was cancelled during the update because the module selected for update was not on the SD card.



### ***Recovery after Power Loss***

If the ROM update is interrupted as a result of accidental loss of power while the firmware is updating, then the correct operation of the machine cannot be guaranteed after the machine is switched on again. If the ROM update does not complete successfully for any reason, then in order to ensure the correct operation of the machine, the ROM update error will continue to show until the ROM is updated successfully.

In this case, insert the card again and switch on the machine to continue the firmware download automatically from the card without the menu display.

### 5.13.3 HANDLING FIRMWARE UPDATE ERRORS

An error message shows in the first line if an error occurs during a download. The error code consists of the letter "E" and a number ("E20", for example).

#### ***Error Message Table***

Code	Meaning	Solution
20	Cannot map logical address	Make sure the SD card is installed correctly, or use a different SD card.
21	Cannot access memory	HDD connection incorrect or replace HDD.
22	Cannot decompress compressed data	Incorrect ROM data on the SD card, or data is damaged.
23	Error occurred when ROM update program started	Controller program defective. If the second attempt fails, replace controller board.
24	SD card access error	Make sure the SD card is inserted correctly, or use a different SD card.
30	No HDD available for stamp data download	HDD connection incorrect or replace HDD.
31	Data incorrect for continuous download	Insert the SD card with the remaining data required for the download, the re-start the procedure.
32	Data incorrect after download interrupted	Execute the recovery procedure for the intended module download, then repeat the installation procedure.
33	Incorrect SD card version	Incorrect ROM data on the SD card, or data is corrupted.
34	Module mismatch - Correct module is not on the SD card)	SD update data is incorrect. Acquire the correct data (Japan, Overseas, OEM, etc.) then install again.

## Updating the Firmware

Code	Meaning	Solution
35	Module mismatch – Module on SD card is not for this machine	SD update data is incorrect. The data on the SD card is for another machine. Acquire correct update data then install again.
36	Cannot write module – Cause other than E34, E35	SD update data is incorrect. The data on the SD card is for another machine. Acquire correct update data then install again.
40	Engine module download failed	Replace the update data for the module on the SD card and try again, or replace the BCU board.
42	Operation panel module download failed	Replace the update data for the module on the SD card and try again, or replace the LCDC.
43	Stamp data module download failed	Replace the update data for the module on the SD card and try again, or replace the hard disks.
44	Controller module download failed	Replace the update data for the module on the SD card and tray again, or replace controller board.
50	Electronic confirmation check failed	SD update data is incorrect. The data on the SD card is for another machine. Acquire correct update data then install again.

## 5.14 UPLOADING/DOWNLOADING NVRAM DATA

The content of the NVRAM can be uploaded to and downloaded from an SD card.

### 5.14.1 UPLOADING NVRAM DATA (SP5-824)

1. Turn off the main switch.



2. Remove the SD card slot cover (🔑 x 1).



3. Insert the SD card into SD card slot 2 (Lower Slot) [A].
4. Turn on the main switch.
5. Execute SP5-824.
6. Press the "EXECUTE" button to start uploading the NVRAM data.

Service  
Tables



## 5.14.2 DOWNLOADING NVRAM DATA (SP5-825)

The following data are not downloaded from the SD card:

- Total counter
- Duplex, A3/DLT/Over 420 mm, Staple counters (system settings).

1. Turn off the main switch.



2. Remove the SD card slot cover [A] (⚙ x 1).



3. Plug the SD card into SD card slot 2 (Lower Slot) [A].

4. Turn on the main switch.

5. Execute SP5-825.

6. Press the "EXECUTE" button to start downloading the NVRAM data.

Note that the following errors could occur during downloading:

- If a card is not installed in the card slot and a message tells you that downloading cannot proceed, you cannot execute downloading, even by pressing the "EXECUTE" button.
- If the correct card for the NVRAM data is not inserted in the card slot, after you press the "EXECUTE" button a message will tell you that downloading cannot proceed because the card is abnormal and the execution will halt.

## 5.15 SELF-DIAGNOSTIC MODE

### 5.15.1 SELF-DIAGNOSTIC MODE AT POWER ON

As soon as the main machine is powered on, the controller waits for the initial settings of the printer engine to take effect and then starts an independent self-diagnostic test program. The self-diagnostic test follows the path of the flow chart shown below and checks the CPU, memory, HDD, and so on. An SC code is displayed in the touch panel if the self-diagnostic program detects any malfunction or abnormal condition.

### 5.15.2 SELF-DIAGNOSTIC TEST FLOW

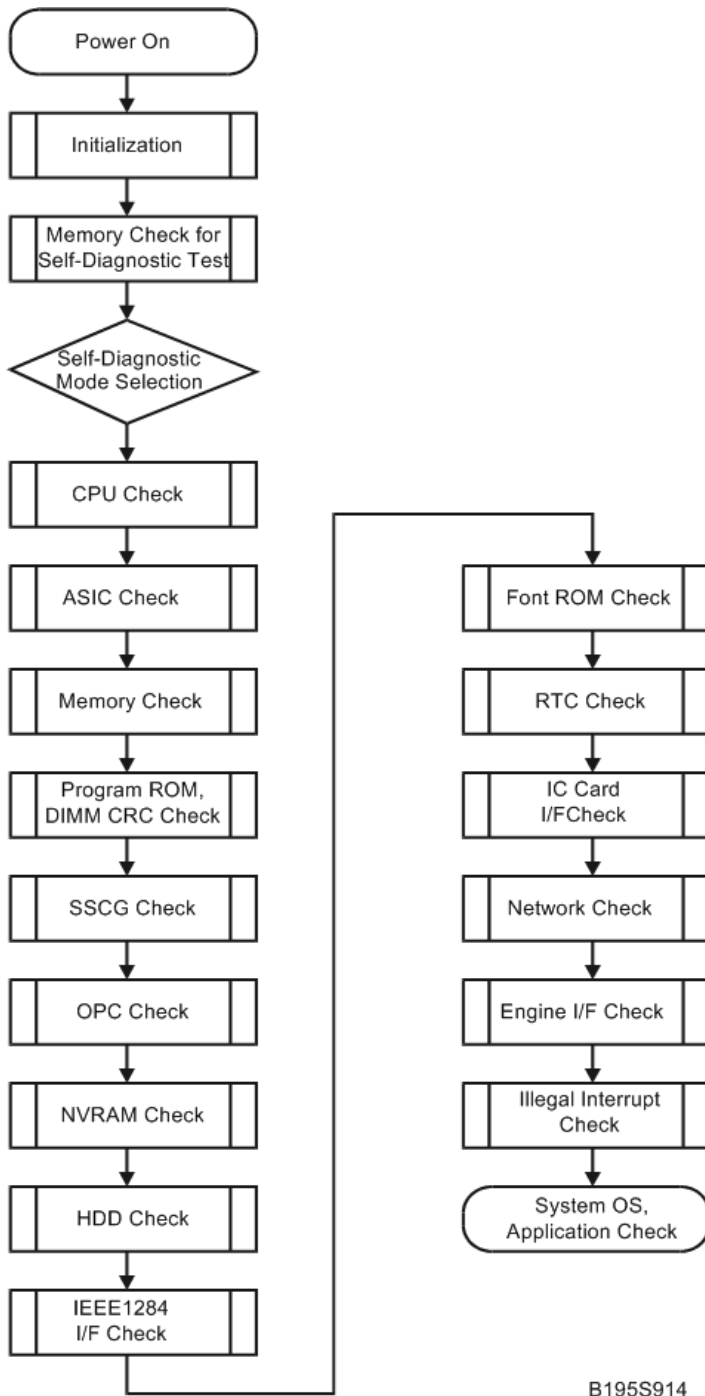

### 5.15.3 DETAILED SELF-DIAGNOSTIC MODE

Do not use the detailed self-diagnostic mode in this model.

This mode is only for factory use to test other components or conditions that are not tested during self-diagnosis after power on.

If you entered the self-diagnostic mode by accident, turn the main power switch off and on.

## 5.16 USING THE DEBUG LOG

### 5.16.1 OVERVIEW

This machine provides a Save Debug Log feature that allows the Customer Engineer to save and retrieve error information for analysis.

Every time an error occurs, debug information is recorded in volatile memory but this information is lost when the machine is switched off and on.

To capture this debug information, the Save Debug Log feature provides two main features:

- Switching on the debug feature so error information is saved directly to the HDD for later retrieval.
- Copying the error information from the HDD to an SD card.

When a user is experiencing problems with the machine, follow the procedure below to set up the machine so the error information is saved automatically to the HDD. Then ask the user to reproduce the problem.

### 5.16.2 SWITCHING ON AND SETTING UP SAVE DEBUG LOG

The debug information cannot be saved until the "Save Debug Log" function has been switched on and a target has been selected.

1. Enter the SP mode.
2. Select "Engine" SP.
3. Under "5857 Save Debug Log", press "1 On/Off (1:ON 0:OFF)".

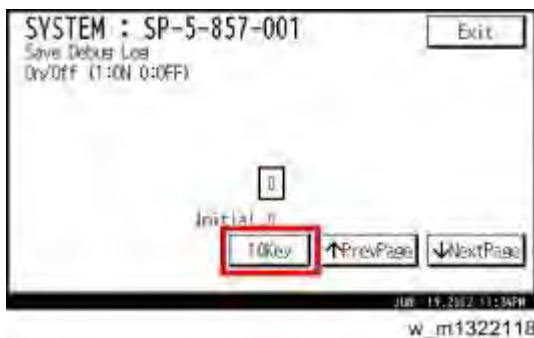

4. Press "10Key" to open the number entry screen.



5. Enter "1" then press "OK". This switches the Save Debug Log feature on.

## Using the Debug Log

### Note

- The default setting is "0" (OFF). This feature must be switched on in order for the debug information to be saved.
6. Next, select the target destination where the debug information will be saved. Under "5857 Save Debug Log", press "2 Target (2:HDD 3:SD)".

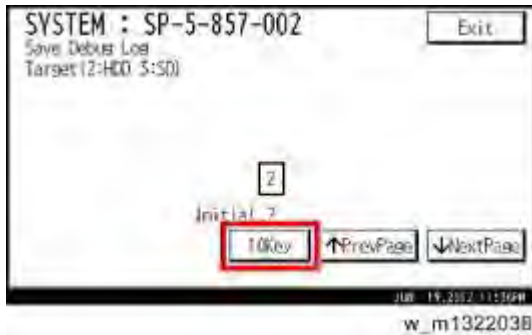

7. Press "10Key" to open the number entry screen.



8. Enter "2" to select the hard disk as the target destination, and then press "OK".

### Note

- Enter "3" to save the debug information directly to the SD card if it is inserted in Slot 2 (Lower Slot).
9. Now touch "5858" and specify the events that you want to record in the debug log. SP5858 (Debug Save When) provides the following items for selection.

1	Engine SC Error	Saves data when an engine-related SC code is generated.
2	Controller SC Error	Saves debug data when a controller-related SC Code is generated.
3	Any SC Error	Saves data only for the SC code that you specify by entering code number.
4	Jam	Saves data for jams.

**Note**

- More than one event can be selected.

**Example 1: To Select Items 1, 2, 4**

Touch the appropriate item(s) and press "10Key". On the number entry screen, enter "1", and then press "OK". Do the same settings for each selection. This example shows "Engine SC Error" selected.

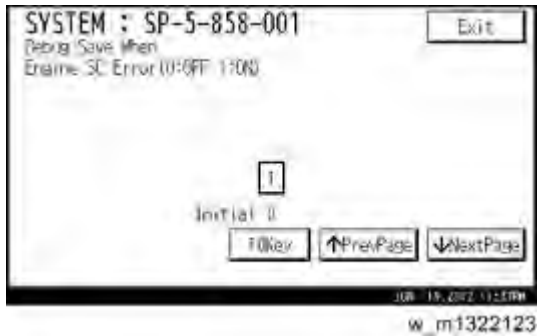

**Example 2: To Specify an SC Code**

Touch "3 Any SC Error" and press "10Key". On the number entry screen, enter the 3-digit SC code number, and then press "OK". This example shows an entry for SC670.

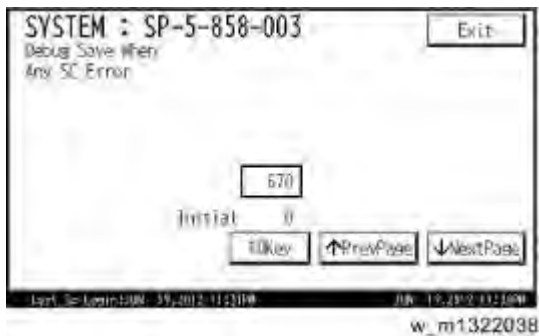

**Note**

- For details about SC code numbers, please refer to the SC tables in Section "6. Troubleshooting"

- Next, select the one or more memory modules for reading and recording debug information. Touch "5859". Under "5859" press the appropriate key item for the module that you want to record. Press "10Key" to open the number entry screen. Enter the appropriate 4-digit number, then press "OK".

**Note**

- Refer to the two tables below for the 4-digit numbers to enter for each key.

The example below shows "Key 1" with "2222" entered.

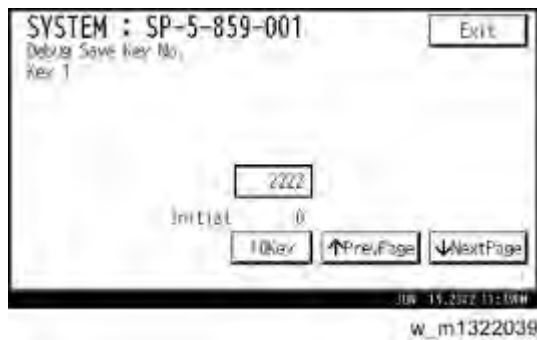

The following keys can be set with the corresponding numbers. (The initials in parentheses indicate the names of the modules.)

**4-Digit Entries for Keys 1 to 10**

Key No.	Printer	Web
1	2222 (SCS)	
2	2223 (SRM)	
3	256 (IMH)	
4	1000 (ECS)	
5	1025 (MCS)	
6	4400 (GPS)	5682 (NFA)
7	4500 (PDL)	6600 (WebDB)
8	4600 (GPS-PM)	3300 (PTS)
9	2000 (NCS)	6666 (WebSys)
10	2224 (BCU)	2000 (NCS)

**Note**

- The default settings for Keys 1 to 10 are all zero ("0").

**Key to Acronyms**

Acronym	Meaning	Acronym	Meaning
ECS	Engine Control Service	NFA	Net File Application
GPS	GW Print Service	PDL	Printer Design Language
GSP-PM	GW Print Service – Print Module	PTS	Print Server
IMH	Image Memory Handler	SCS	System Control Service
MCS	Memory Control Service	SRM	System Resource Management
NCS	Network Control Service	WebDB	Web Document Box (Document Server)

The machine is now set to record the debugging information automatically on the SD card or HDD (the target selected with SP5-857-002) for the events that you selected SP5-858 and the memory modules selected with SP5-859.

Please keep the following important points in mind when you are doing this setting:

- The initial settings are all zero.
- These settings remain in effect until you change them. Be sure to check all the settings, especially the settings for Keys 6 to 10. To switch off a key setting, enter a zero for that key.
- You can select any number of keys from 1 to 10 (or all) by entering the corresponding 4-digit numbers from the table.
- One area of the disk is reserved to store the debug log. The size of this area is limited to 4 MB.



### ***Retrieving the Debug Log from the HDD***

1. Insert the SD card into Slot 2 (Lower Slot).
2. Enter the SP mode and execute SP5857-009 (Copy HDD to SD Card (Latest 4 MB)) to write the debugging data to the SD card.

 **Note**

- The SD card can hold up to 4MB of data. If the debugging data is larger than 4MB, you can switch to another SD card.
3. Use a card reader to copy the file and send it for analysis to your local Ricoh representative by email, or just send the SD card by mail.

## 5.17 SMC LIST CARD SAVE FUNCTION

### 5.17.1 OVERVIEW

#### **SMC List Card Save**

The SMC List Card Save (SP Text Mode) function is used to save the SMC list as CSV files to the SD-card inserted into the operation panel SD-card slot.

### 5.17.2 PROCEDURE

1. Turn the main power switch OFF.
2. Insert the SD card into the operation panel SD-card slot. Then turn the power ON.
3. Enter SP mode.
4. Select "Engine" SP.



5. Select SP-5992 "SP Text Mode".
6. Select a detail SP number shown below to save data on the SD card.  
SP-5992-xxx (SP Text Mode)

Detail No.	SMC Categories to Save
001	All (Data List)
002	SP (Mode Data List)
003	User Program
004	Logging Data
005	Diagnostic Report
006	Non-Default
007	NIB Summary

Service Tables

## SMC List Card Save Function

Detail No.	SMC Categories to Save
024	SDK/J Summary
025	SDK/J Application Info
026	Printer SP



- Press "EXECUTE".



- Press "EXECUTE" again to start. Press "CANCEL" to cancel the saving.
- "It is executing it." is shown on the screen while executing.
- Wait for 2 to 3 minutes until "Completed" is shown.

### ↓ Note

- The SMC list saving may take from 2 to 3 minutes to complete.
- Press "CANCEL" to abort executing.



- Press "Exit" to exit from SP mode.

### 5.17.3 FILE NAMES OF THE SAVED SMC LISTS

The SMC list data saved on the SD-card will be named automatically. The file naming rules are as follows.

Example:

T4200000017\_59921\_20120530\_03433.csv

m1322099

- [A]: Machine serial number (fixed for each machine)
- [B]: SP number saved in this file.  
First four digits (5992) in this part are fixed. The other one or two digits are the detail SP number(s). In this case, it is one digit. Therefore, this file is of SP5-992-001 (All data list). See the upper SP table for the correspondence between SP detail numbers and the contents.
- [C]: File creation date  
Year/Month/Day (“Zero” will be omitted if each is one digit.)
- [D]: File creation time  
Hour/Minute/Second (“Zero” will be omitted if each is one digit.)
- [E]: File Extension CSV (Comma Separated Value)  
This part is fixed.

#### ↓ Note

- A folder named by the machine serial number will be created on the SD card when this function is executed.
- This function can save the SMC list data only to an SD card inserted into the operation panel SD card slot.

### 5.17.4 ERROR MESSAGES

SMC List Card Save error message:

- **Failed:**  
FACTOR: Read-only file system, No space left on device.

If an error occurs, pressing “Exit” will cause the device to discard the job and return to the ready state.



# **TROUBLESHOOTING**



## 6. TROUBLESHOOTING

### 6.1 SERVICE CALL CONDITIONS

#### 6.1.1 SUMMARY

There are 4 levels of service call conditions.

Level	Definition	Reset Procedure
A	To prevent damage to the machine, the main machine cannot be operated until the SC has been reset by a service representative (see the note below).	Enter SP mode, use SP 5810, touch [Execute], and then turn the main power switch off and on.
B	SCs that disable only the features that use the defective item. Although these SCs are not shown to the user under normal conditions, they are displayed on the operation panel only when the defective feature is selected.	Turn the operation switch or main switch off and on.
C	The SC history is updated. The machine can be operated as usual.	The SC will not be displayed. Only the SC history is updated.
D	Turning the main switch off then on resets SCs displayed on the operation panel. These are re-displayed if the error occurs again.	Turn the operation switch off and on. Also see below.

#### When a Level "D" SC code occurs

When a Level D SC occurs, a screen opens on the operation panel to tell the operator:

- An error occurred
- The job in progress will be erased
- The machine will reboot automatically after approximately 30 seconds.

The operator can wait until the machine reboots automatically or touch "Reset" on the screen to reset the machine immediately and go back to the Home screen.



**If the operator does not touch "Reset"**

The next message tells the operator that the machine will reset automatically and that the previous job was lost and must be started again. After reading the message, the operator touches "Confirm" on the screen. The next screen shows the number and title of the SC code, and stops until the operator turns the machine off and on.

**If the operator touches "Reset"**

If the operator touches "Reset" to bypass the 30-second interval for the machine to reboot, the machine reboots immediately and the operation panel displays the Home screen.

**Note**

- Do not try to use the operation panel during an automatic reboot.
- If the Remote Service System is in use, the SC code is sent immediately to the Service Center.

### 6.1.2 SC CODE DESCRIPTIONS

**Important**

- If a problem concerns a circuit board, disconnect and reconnect the connectors and then test the machine. Often a loose or disconnected harness is the cause of the problem. Always do this before you decide to replace the PCB.
- If a motor lock error occurs, check the mechanical load before you decide to replace the motor or sensors.
- When a Level "A" or "B" SC occurs while in an SP mode, the machine cannot display the SC number. If this occurs, check the SC number after leaving the SP mode.
- The machine reboots automatically when the machine issues a Level "D" SC code. This is done for Level "D" SC codes only.

**SC Tables: SC1xx**

195	D	Serial Number Mismatch
		Serial number stored in the memory does not have the correct code.
		<ul style="list-style-type: none"> <li>▪ EEPROM defective</li> <li>▪ BCU replaced without original EEPROM</li> </ul>

**SC Tables: SC2xx**

202	D	Polygon motor error 1: ON timeout
		The polygon mirror motor does not reach the targeted operating speed within 10 sec. after turning on or changing speed
203	D	Polygon motor error 2: OFF timeout
		The polygon mirror motor does not leave the READY status within 3 sec. after the polygon motor switched off.
204	D	Polygon motor error 3: XSCRDY signal error
		The SCRDY_N signal remains HIGH for 200 ms while the LD unit is firing.
		<ul style="list-style-type: none"> <li>▪ Polygon motor/driver board harness loose or broken</li> <li>▪ Polygon motor/driver board defective</li> <li>▪ Laser optics unit defective</li> <li>▪ Bridge board defective</li> </ul>

220	D	Laser synchronizing detection error: start position LD0
		The laser synchronizing detection signal for the start position of the LDB is not output for two seconds after LDB unit turns on while the polygon motor is rotating normally
		<ul style="list-style-type: none"> <li>▪ Disconnected cable from the laser synchronizing detection unit or defective connection</li> <li>▪ Defective laser synchronizing detector</li> <li>▪ Defective LD board</li> <li>▪ Defective BCU</li> </ul>

Service Call Conditions

221	D	Laser synchronizing detection error: start position LD1
		The laser synchronizing detection signal for the start position of the LDB is not output for two seconds after LDB unit turns on while the polygon motor is rotating normally.
		<ul style="list-style-type: none"> <li>▪ Disconnected cable from the laser synchronizing detection unit or defective connection</li> <li>▪ Defective laser synchronizing detector</li> <li>▪ Defective LD board</li> <li>▪ Defective BCU</li> </ul>

230	D	FGATE ON error
		The FGATE signal does not assert within the prescribed time. (The bridge board generates the FGATE signal and sends it to the LD unit when the registration sensor switches on.)

231	D	FGATE OFF error
		The FGATE signal does not assert within the prescribed time. (The bridge board generates the FGATE signal and sends it to the LD unit when the registration sensor switches on.)
		<ul style="list-style-type: none"> <li>▪ BCU, Controller board harness loose or broken</li> <li>▪ Controller board defective</li> <li>▪ BCU defective</li> </ul>

240	C	LD error
		The bridge board detected a problem at the LD unit.
		<ul style="list-style-type: none"> <li>▪ Worn-out LD</li> <li>▪ Disconnected or broken harness of the LD.</li> </ul>

270	D	GAVD communication error
		<ul style="list-style-type: none"><li>▪ The I2C bus device ID is not identified during initialization.</li><li>▪ A device-status error occurs during I2C bus communication.</li><li>▪ The I2C bus communication is not established due to an error other than a buffer shortage.</li></ul>
		<ul style="list-style-type: none"><li>▪ BCU, Bridge board harness loose or broken</li><li>▪ Defective bridge board</li><li>▪ Defective BCU</li><li>▪ Defective LD controller board</li></ul>

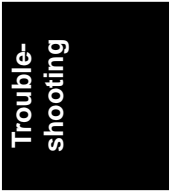

**SC Tables: SC3xx**

302	D	Charge roller bias leak
		A charge roller bias leak signal was detected.
		<ul style="list-style-type: none"> <li>▪ Charge roller damaged</li> <li>▪ High voltage supply board defective</li> <li>▪ PCDU harness defective or disconnected</li> </ul>

304	D	Charge roller bias correction leak
		The charge roller bias correction is performed twice even if the maximum charge roller bias (-2000V) is applied to the roller.
		<ul style="list-style-type: none"> <li>▪ ID sensor defective</li> <li>▪ Worn charge roller</li> <li>▪ Charge roller damaged</li> </ul>

320	D	Development roller bias leak
		The development roller bias leak is detected for 60 ms after the high voltage has been supplied to the development unit.
		<ul style="list-style-type: none"> <li>▪ Development bias leak</li> <li>▪ Broken harness</li> <li>▪ Defective high voltage power supply, voltage supply</li> <li>▪ Defective high voltage supply unit</li> </ul>

324	D	Development puddle motor error
		The machine detects a lock signal error from the development puddle motor for 2 seconds after the drum motor has turned on.
		<ul style="list-style-type: none"> <li>▪ Overload on the development puddle motor</li> <li>▪ Defective development puddle motor</li> <li>▪ Defective harness</li> <li>▪ Defective IOB</li> </ul>

350	D	ID sensor pattern test error
		<p>One of the following readings occurred 10 times in the ID sensor output when the ID sensor pattern was checked:</p> <p>1) <math>V_{sp} &gt; 2.5V</math>                  2) <math>V_{sg} &lt; 2.5V</math>                  3) <math>V_{sp} = 0V</math>                  4) <math>V_{sg} = 0V</math></p>
		<ul style="list-style-type: none"> <li>▪ ID sensor connector defective</li> <li>▪ Poor ID sensor connector connection</li> <li>▪ I/O board (IOB) defective</li> <li>▪ Poor writing of ID sensor pattern on the drum</li> <li>▪ High voltage supply board defective</li> </ul>

351	D	ID sensor $V_{sg}$ test error
		<p>When the ID sensor was checked, the ID sensor output voltage is 5.0V while the LED current value is 0.</p>
		<ul style="list-style-type: none"> <li>▪ ID sensor defective or dirty</li> <li>▪ ID sensor connector defective</li> <li>▪ Poor ID sensor connection</li> <li>▪ I/O board (IOB) defective</li> <li>▪ High voltage supply board defective</li> <li>▪ Defect at the ID sensor pattern writing area of the drum</li> </ul>

355	C	Grayscale measurement error
		<p>When the grayscale control result is the maximum and it does not operate correctly and these cases are detected 15 times.</p>
		<ul style="list-style-type: none"> <li>▪ ID sensor defective or dirty</li> <li>▪ The life of ID sensor or photo conductor</li> <li>▪ Shield glass dirty</li> </ul>

Trouble-shooting

Service Call Conditions

360	D	TD sensor (Vt) error 1
		The following condition occurs thirty times consecutively during printing. Vt is less than 0.5V or 4.8V or more
		<ul style="list-style-type: none"> <li>▪ TD sensor disconnected</li> <li>▪ Harness between TD sensor and PCDU defective</li> <li>▪ Defective TD sensor.</li> </ul>

372	D	TD sensor adjustment error
		Vts is less than 1.8V or 4.8V or more during TD sensor initialization.
		<ul style="list-style-type: none"> <li>▪ Heat seal not removed from a new developer pack</li> <li>▪ TD harness sensor disconnected, loose or defective</li> <li>▪ TD sensor defective</li> <li>▪ Harness between TD sensor and drawer disconnected, defective</li> </ul>

396	D	Drum motor error
		The machine detects a lock signal error from the drum motor for 2 seconds after the drum motor turned on.
		<ul style="list-style-type: none"> <li>▪ Overload on the motor</li> <li>▪ Defective drum motor</li> <li>▪ Defective harness</li> <li>▪ Defective IOB</li> </ul>

**SC Tables: SC4xx**

400	D	Vsg adjustment error
		Vsg is more than 4.2V or 3.8V or less when the machine adjusts Vsg value.
		<ul style="list-style-type: none"> <li>▪ Dirty or defective ID sensor</li> <li>▪ Defective ID sensor shutter</li> </ul>

440	D	Transfer belt bias error
		The feed back bias from the transfer belt is more than 4V for 60 msec while the transfer belt bias is output.
		The A/D conversion level is 20 or less for 60 msec.
		The PWM duty is 24% or more for 60 msec.
		<ul style="list-style-type: none"> <li>▪ Power pack broken</li> <li>▪ Defective harness</li> <li>▪ Disconnected connector</li> </ul>

441	D	Transfer/Development motor error
		The machine detects a lock signal error from the transfer/development motor for a continuous 20 times after the transfer/development motor turned on.
		<ul style="list-style-type: none"> <li>▪ Overload on the motor</li> <li>▪ Defective transfer/development motor</li> <li>▪ Defective harness</li> <li>▪ Defective IOB</li> </ul>

Trouble-shooting



Service Call Conditions

442	D	Transfer belt contact motor error
		The transfer belt HP sensor detects incorrect movement of the transfer belt after the transfer belt contact motor has turned on.
		<ul style="list-style-type: none"><li>▪ Dirty transfer belt HP sensor</li><li>▪ Defective transfer belt contact motor</li><li>▪ Disconnected connector of the transfer belt HP sensor or motor</li><li>▪ Disconnected cable</li><li>▪ Defective IOB</li></ul>

**SC Tables: SC5xx**

501	B	1st tray lift malfunction
		The tray lift sensor is not activated after the tray lift motor has been on for 10 seconds. If the main power switch is turned on when the paper is already at the feed height, the paper height position is detected again. At this time, the tray lift sensor should de-activate within 1.5 sec after the paper bottom plate starts to drop. If it does not deactivate within 1.5 sec., a message will prompt the user to reset Tray 1. After two attempts to release the error by re-setting the paper tray, if this does not solve the problem then this SC is displayed.
		<ul style="list-style-type: none"> <li>▪ An obstruction (jammed paper, paper scraps, etc.) has blocked the motor drive and caused an overload.</li> <li>▪ Tray lift sensor connection loose, disconnected, or damaged</li> <li>▪ Tray lift sensor defective</li> <li>▪ Tray lift motor connection loose, disconnected, or damaged</li> <li>▪ Tray lift motor defective</li> </ul>

502	B	2nd tray lift malfunction
		The tray lift sensor is not activated after the tray lift motor has been on for 10 seconds. If the main power switch is turned on when the paper is already at the feed height, the paper height position is detected again. At this time, the tray lift sensor should de-activate within 1.5 sec. after the paper bottom plate starts to drop. If it does not deactivate within 1.5 sec., a message will prompt the user to reset Tray 2. After two attempts to re-set the paper tray, if this does not solve the problem then this SC is displayed.
		<ul style="list-style-type: none"> <li>▪ An obstruction (jammed paper, paper scraps, etc.) has blocked the motor drive and caused an overload.</li> <li>▪ Tray lift sensor connection loose, disconnected, or damaged</li> <li>▪ Tray lift sensor defective</li> <li>▪ Tray lift motor connection loose, disconnected, or damaged</li> <li>▪ Tray lift motor defective</li> </ul>

Trouble-shooting

503	B	3rd tray lift malfunction (optional paper feed unit or LCT)
		<p><b>For the paper feed unit:</b></p> <ul style="list-style-type: none"> <li>▪ The lift sensor does not turn on within 15 seconds after the tray lift motor has turned on.</li> <li>▪ When the tray lowers, the tray lift sensor does not go off within 1.5 sec. If this condition occurs three consecutive times, the SC is generated.</li> </ul> <p><b>For the LCT:</b></p> <ul style="list-style-type: none"> <li>▪ The lift sensor does not turn on or turn off within 8 seconds after the tray lift motor has turned on to lift or lower the tray.</li> <li>▪ When the main switch is turned on or when the LCT is set, if the end fence is not in its position (home position sensor ON), the tray lift motor stops. If this condition occurs three consecutive times, the SC is generated.</li> <li>▪ If the upper limit does not go off for 1.5 seconds even the tray lift motor turns on to lower the tray after the upper limit has been detected at power on. If this condition occurs three consecutive times, the SC is generated.</li> <li>▪ The paper is detected in the left tray even the end fence is not its position (home position sensor OFF) after the left tray set switch is on at power on. If this condition occurs three consecutive times, the SC is generated.</li> </ul>
		<p><b>For the paper feed unit:</b></p> <ul style="list-style-type: none"> <li>▪ Defective tray lift motor or connector disconnection</li> <li>▪ Defective lift sensor or connector disconnection</li> </ul> <p><b>For the LCT:</b></p> <ul style="list-style-type: none"> <li>▪ Defective stack transport clutch or connector disconnection</li> <li>▪ Defective tray motor or connector disconnection</li> <li>▪ Defective end fence home position sensor or connector disconnection</li> <li>▪ Defective upper limit sensor or connector disconnection</li> <li>▪ Defective tray lift motor or connector disconnection</li> <li>▪ Defective pick-up solenoid or connector disconnection</li> <li>▪ Left tray set switch or connector disconnection</li> </ul>

504	B	4th tray lift malfunction (optional paper feed unit or LCT)
		<p><b>For the two-tray paper feed unit:</b></p> <ul style="list-style-type: none"> <li>▪ When the tray lift motor is turned on, the upper limit is not detected within 15 seconds. If this condition occurs three consecutive times, the SC is generated.</li> <li>▪ When the tray lowers, the tray lift sensor does not go off within 1.5 sec.</li> </ul> <p><b>For the LCT:</b></p> <ul style="list-style-type: none"> <li>▪ After the job is finished, if the end fence is not in the home position (home position sensor ON), the tray lift motor stops.</li> <li>▪ When the main switch is turned on or when the paper feed unit is set, if the end fence is not in the home position (home position sensor ON), the tray lift motor stops. If this condition occurs three consecutive times, the SC is generated.</li> <li>▪ If the upper or lower limit is not detected within 8 seconds when the tray lift motor is turned on to lift up or lower the tray.</li> <li>▪ When the tray lowers, the tray lift sensor does not go off within 1.5 sec.</li> </ul>
		<p><b>For the paper feed unit:</b></p> <ul style="list-style-type: none"> <li>▪ Defective tray lift motor or connector disconnection</li> <li>▪ Defective lift sensor or connector disconnection</li> </ul> <p><b>For the LCT:</b></p> <ul style="list-style-type: none"> <li>▪ Defective tray lift motor or connector disconnection</li> <li>▪ Defective lift sensor or connector disconnection</li> </ul>

505	B	5th tray lift malfunction (optional paper feed unit or LCT)
		<p><b>For the two-tray paper feed unit:</b></p> <ul style="list-style-type: none"> <li>▪ If the upper limit of the two-tray paper feed unit is not detected within 15 seconds when the tray lift motor is turned on to lift up the tray.</li> <li>▪ When the tray lowers, the tray lift sensor does not go off within 1.5 sec. If this condition occurs three consecutive times, the SC is generated.</li> </ul> <p><b>For the LCT:</b></p> <ul style="list-style-type: none"> <li>▪ If the upper limit of the LCT 1200-sheet is not detected within 8 seconds when the tray lift motor is turned on to lift up or lower the tray.</li> <li>▪ The tray lift sensor of the LCT 1200-sheet does not go off within 1.5 seconds when the tray lowers. If this condition occurs three consecutive times, the SC is generated.</li> </ul>
		<ul style="list-style-type: none"> <li>▪ Tray lift motor defective or disconnected</li> <li>▪ Upper limit sensor defective or disconnected</li> </ul>

530	D	Fusing exhaust fan motor error
		The IOB does not receive the lock signal for 10 seconds after turning on the fusing exhaust fan.
		<ul style="list-style-type: none"> <li>▪ Defective fusing exhaust fan motor or connector disconnection</li> <li>▪ Defective IOB</li> <li>▪ Disconnected harness</li> </ul>

531	D	Exhaust fan motor error
		The IOB does not receive the lock signal for 10 seconds after turning on the exhaust fan motor.
		<ul style="list-style-type: none"> <li>▪ Defective exhaust fan motor or connector disconnection.</li> <li>▪ Defective IOB</li> <li>▪ Disconnected harness</li> </ul>

532	D	Cooling fan motor error
		The machine does not detect the fan motor lock signal for 10 seconds after turning on the cooling fan motor.
		<ul style="list-style-type: none"> <li>▪ Defective cooling fan motor or connector disconnection.</li> <li>▪ Disconnected harness</li> <li>▪ Defective IOB</li> </ul>

533	D	Paper exit cooling fan motor error
		The machine does not detect the fan motor lock signal for 10 seconds after turning on the paper exit cooling fan motor.
		<ul style="list-style-type: none"> <li>▪ Defective paper exit cooling fan motor or connector disconnection.</li> <li>▪ Defective IOB</li> <li>▪ Disconnected harness</li> </ul>

540	D	Fusing motor error
		The IOB does not receive the lock signal for 2 seconds after turning on the fusing motor.
		<ul style="list-style-type: none"> <li>▪ Motor overload</li> <li>▪ Defective fusing motor or connector disconnection.</li> <li>▪ Defective IOB</li> <li>▪ Disconnected harness</li> </ul>

541	A	Fusing thermistor open (center)
		The thermistor (center) detects 0°C or less for 16 sec. in a row.
		<ul style="list-style-type: none"> <li>▪ Fusing thermistor disconnected</li> <li>▪ Fusing thermistor connector defective</li> </ul>

Service Call Conditions

542	A	Fusing temperature warm-up error(center)
		<p>This SC is generated if the following condition occurs:</p> <ul style="list-style-type: none"> <li>▪ The thermistor (center) does not detect an 8°C increment in the fusing temperature for 1.5 sec. just after the fusing temperature reached 45°C.</li> <li>▪ The temperature of the center thermistor does not reach 60°C for 7 seconds after the fusing lamps turned on.</li> <li>▪ The temperature of the center thermistor does not reach the target temperature for 26 seconds after the fusing lamps turned on.</li> </ul>
		<ul style="list-style-type: none"> <li>▪ Thermistor warped or broken</li> <li>▪ Input voltage is unwarranted</li> </ul>

543	A	Fusing overheat error 1 (software detection)
		<p>A fusing temperature (at the center) of over 230°C (446°F) is detected for 1 second by the fusing thermistors at the center or at either end of the fusing roller.</p>
		<ul style="list-style-type: none"> <li>▪ Power supply unit defective</li> <li>▪ I/O board (IOB) defective</li> <li>▪ BCU defective</li> <li>▪ TRIAC short on PSU (PSU defective)</li> </ul>

544	A	Fusing overheat error 1 (hardware detection)
		<p>A fusing temperature (at the center) over 250°C is detected by the fusing temperature monitor circuit in the BCU board.</p>
		<ul style="list-style-type: none"> <li>▪ I/O board (IOB) defective</li> <li>▪ BCU defective</li> <li>▪ TRIAC short on bridge board (bridge board defective)</li> </ul>

545	A	Fusing lamp consecutive full power 1
		After warm-up the fusing lamp remains at full power for 10 seconds without the hot roller rotating.
		<ul style="list-style-type: none"> <li>▪ Thermistors (center) warped</li> <li>▪ Disconnected or defective thermistors (center)</li> <li>▪ Defective fusing lamp</li> </ul>

547	D	Zero cross error
		<ul style="list-style-type: none"> <li>▪ The zero cross signal is detected three times even though the heater relay is off when turning on the main power.</li> <li>▪ The zero cross signal is not detected for 2 seconds even though the heater relay is on after turning on the main power or closing the front door.</li> <li>▪ The detection error occurs twice or more in the 11 zero cross signal detections. This error is defined when the detected zero cross signal is less than 45.</li> </ul>
		<ul style="list-style-type: none"> <li>▪ Defective fusing lamp relay</li> <li>▪ Defective fusing lamp relay circuit</li> <li>▪ Unstable power supply</li> </ul>

551	A	Fusing thermistor open (end)
		The thermistor (end) detects 0°C or less for 16 sec.
		<ul style="list-style-type: none"> <li>▪ Fusing thermistor (end) disconnected</li> <li>▪ Fusing thermistor (end) connector defective</li> </ul>



Service Call Conditions

552	A	Fusing temperature warm-up error (end)
		<p>This SC is generated if the following condition occurs:</p> <ul style="list-style-type: none"> <li>▪ The thermistor (end) does not detect an 8°C increment in the fusing temperature for 1.5 sec. just after the fusing temperature reached 45°C.</li> <li>▪ The temperature of the center thermistor does not reach 60°C for 7 seconds after the fusing lamps turned on.</li> <li>▪ The temperature of the end thermistor does not reach the target temperature for 26 seconds after the fusing lamps turned on.</li> </ul>
		<ul style="list-style-type: none"> <li>▪ Thermistor warped or broken</li> <li>▪ Input voltage is unwarranted</li> </ul>

553	A	Fusing overhear error 2 (software detection)
		<p>A fusing temperature (at the end) of over 230°C (446°F) is detected for 1 second by the fusing thermistors at the center or at either end of the fusing roller.</p>
		<ul style="list-style-type: none"> <li>▪ Power supply unit defective</li> <li>▪ I/O board (IOB) defective</li> <li>▪ BCU defective</li> <li>▪ TRIAC short on bridge board (bridge board defective)</li> </ul>

554	A	Fusing overhear error 2 (hardware detection)
		<p>A fusing temperature (at the end) over 250°C is detected by the fusing temperature monitor circuit in the BCU board.</p>
		<ul style="list-style-type: none"> <li>▪ I/O board (IOB) defective</li> <li>▪ BCU defective</li> <li>▪ TRIAC short on bridge board (bridge board defective)</li> </ul>

555	A	Fusing lamp consecutive full power 2
		After warm-up, the fusing lamp remains at full power for 10 seconds without the hot roller rotating.
		<ul style="list-style-type: none"> <li>▪ Thermistor (ends) warped</li> <li>▪ Disconnected or defective thermistors (ends)</li> <li>▪ Defective fusing lamp</li> </ul>

557	C	Zero cross frequency error
		When the zero cross signal is 66 or more and it is detected 10 times or more in 11 detections, the machine determines that input 60 Hz and SC557 occurs.
		<ul style="list-style-type: none"> <li>▪ Noise (High frequency)</li> </ul>

559	A	Fusing unit jam
		The fusing sensor detected a fusing unit paper late jam three times. The paper was late and the fusing exit sensor could not detect the paper three times.
		<ul style="list-style-type: none"> <li>▪ Remove the paper that is stopped in the fusing unit.</li> <li>▪ Check that the fusing unit is clean and has no obstacles in the paper feed path.</li> <li>▪ If the error persists, replace the fusing unit.</li> </ul>

**★ Important**

- SC559 does not operate until SP1159 has been set to "1" (ON). This sets the machine to count the number of occurrences of paper late jams in the fusing unit. The default setting is "0" (OFF).
- SC559 is issued after the third occurrence of a paper late jam in the fusing unit. Once this SC has been issued, the machine cannot be used until the service technician removes the cause of the jam and restores it to normal operation.
- The jam counter is reset after a sheet of paper successfully passes the fusing exit sensor after the cause of the jam has been removed.

**SC Tables: SC6xx**

610	D	Mechanical counter error: BK
		This SC is only for NA models. The machine detects the mechanical counter error when SP5987-001 is set to "1".
		<ul style="list-style-type: none"> <li>▪ Disconnected mechanical counter</li> <li>▪ Defective mechanical counter</li> </ul>

621	D	Communication timeout error between IOB and finisher or mailbox
		<ul style="list-style-type: none"> <li>▪ The IOB receives the break signal which is generated by the finisher or the mailbox only just after the main switch is turned on.</li> <li>▪ The IOB receives the break signal which is generated by URAT.</li> </ul>
		<ul style="list-style-type: none"> <li>▪ Defective main control board of the peripheral</li> <li>▪ Defective BCU or IOB</li> <li>▪ Disconnected peripheral</li> </ul>

622	D	Paper feed unit communication error
		While the IOB communicates with a peripheral, an SC code is displayed if one of following conditions occurs. <ul style="list-style-type: none"> <li>▪ The IOB receives the break signal which is generated by the peripheral only just after the main switch is turned on.</li> <li>▪ The IOB receives the break signal which is generated by URAT.</li> </ul>
		<ul style="list-style-type: none"> <li>▪ Defective main control board of the peripheral</li> <li>▪ Defective BCU or IOB</li> <li>▪ Disconnected peripheral</li> </ul>

623	D	2nd Paper Bank communication error
		This SC is not issued for this machine. When a communication error signal between the 1st paper bank and 2nd paper bank is received.
		<ul style="list-style-type: none"> <li>▪ Loose connector</li> </ul>

636	D	IC Card Error
-01	-	External authentication module error
		This SC is generated if the external authentication is enabled and following condition occurs: <ul style="list-style-type: none"> <li>▪ No external authentication module</li> <li>▪ SD card error or external authentication module broken</li> <li>▪ No DESS module</li> </ul>
-02	-	Version error
		The version of the external authentication module is not correct. <ul style="list-style-type: none"> <li>▪ Incorrect module version</li> </ul>
-11	-	OSM User Code File Error
		The correct "usercode" file could not be found in the root folder of the SD card because the file is not present, or the existing file is corrupted or the wrong type file.
		Make sure the "usercode" file is installed in the root folder of the SD card where the eccm.mod file is saved. <b>Note:</b> Check the eccm.mod file is in the root folder of the SD card.

Service Call Conditions

637	D	Tracking Information Notice Error
-01	-	Tracking Application Error
		When the tracking information is lost, this SC is issued.
		<ul style="list-style-type: none"> <li>▪ The machine failed to give notice the tracking information to the tracking SDK application.</li> <li>▪ Tracking information is lost, and the machine cannot count correctly.</li> </ul>
-02	-	Tracking Information Notice Error
		When the tracking information is lost, this SC is issued.
		<ul style="list-style-type: none"> <li>▪ The machine failed to give notice the tracking information to the management server.</li> <li>▪ Tracking information is lost, and the machine cannot count correctly.</li> </ul>

641	D	BCU communication error
		The BCU does not respond to the frame transmitted from the controller.
		<ul style="list-style-type: none"> <li>▪ Defective controller</li> <li>▪ Detective BCU</li> </ul>

650	B	Communication error of the remote service modem (Embedded RCG-N)
-05	-	Communication line error
		The supplied voltage is not sufficient due to a defective communication line or defective connection.
		<ul style="list-style-type: none"> <li>▪ Incorrect SP settings</li> <li>▪ Disconnected telephone line</li> <li>▪ Disconnected modem board</li> </ul> Consult with the user's local telephone company.
-14	-	Modem board error 2
		The modem board is installed even though the RCG-N is installed.
		<ul style="list-style-type: none"> <li>▪ Disconnect the Wireless LAN or Ethernet LAN board</li> </ul> <ol style="list-style-type: none"> <li>1. Uninstall the modem board, if it is installed.</li> <li>2. Check that the Wireless LAN or Ethernet LAN is working properly.</li> </ol>

651	C	Incorrect dial up connection
		-01: Program parameter error
		-02: Program execution error
		An unexpected error occurs when the modem (Embedded RCG-M) tries to call the center with a dial up connection.
		<ul style="list-style-type: none"> <li>▪ Caused by a software bug</li> </ul>

652	D	ID2 mismatching
		ID2 for @Remote certification is mismatching between the controller board and NVRAM.
		<ul style="list-style-type: none"> <li>▪ Used controller board installed</li> <li>▪ Used NVRAM installed</li> </ul>
		An unexpected error occurs when the modem (Embedded RCG-M) tries to call the center with a dial up connection.
		<ol style="list-style-type: none"> <li>1. Install the correct controller board or new controller board.</li> <li>2. Install the correct NVRAM or new NVRAM.</li> </ol>

653	D	ID2 error
		ID2 stored in the NVRAM is incorrect.
		<ul style="list-style-type: none"> <li>▪ Used NVRAM installed</li> </ul>
		An unexpected error occurs when the modem (Embedded RCG-M) tries to call the center with a dial up connection.
		Clear the ID2 in the NVRAM, and then input a correct ID2.

669	D	EEPROM error	
-	-	[1]	Open communication error: ID error
		[2]	Open communication error: Channel error
		[3]	Open communication error: Device error
		[4]	Open communication error: Communication failed error
		[5]	Open communication error: Communication time error
		[6]	Open communication error: Communication suspended error
		[7]	Open communication error: Buffer full error
		[8]	Close communication error: No error code

		[9]	Close communication error: ID error
		[10]	Close communication error: No error code
		[11]	Data write error: ID error
		[12]	Data write error: Channel error
		[13]	Data write error: Device error
		[14]	Data write error: Communication suspended error
		[15]	Data write error: Communication time over error
		[16]	Data write error: Communication suspended error
		[17]	Data write error: Buffer full error
		[18]	Data write error: No error code
		[19]	Data read error: ID error
		[20]	Data read error: Channel error
		[21]	Data read error: Device error
		[22]	Data read error: Communication failed error
		[23]	Data read error: Communication time over error
		[24]	Data read error: Communication suspended error
		[25]	Data read error: Buffer full error
		[26]	Data read error: No error code
		[27]	Device detection error: ID error
		[28]	Device detection error: Channel error
		[29]	Device detection error: Device error
		[30]	Device detection error: Communication failed error
		[31]	Device detection error: Communication time over error
		[32]	Device detection error: Communication suspended error
		[33]	Device detection error: Buffer full error



Service Call Conditions

		[34]	Device detection error: No error code
			Retry of EEPROM communication fails three times after the machine has detected the EEPROM error.
			<ul style="list-style-type: none"> <li>▪ Caused by noise</li> </ul>

			Engine startup error
670	D		The BCU fails to respond with the prescribed time when the machine is turned on.
			<ul style="list-style-type: none"> <li>▪ Connections between BCU and controller board are loose, disconnected, or damaged</li> </ul> <ol style="list-style-type: none"> <li>1. Replace the BCU</li> <li>2. Replace the controller board</li> </ol>

			Transmission error in controller board
674	D		Video transmission error is detected in the controller board.
			<ul style="list-style-type: none"> <li>▪ Defective Controller Board</li> </ul>

			Memory address (PER) command error
687	D		The BCU does not receive a memory address command from the controller for the prescribed time after the paper has reached the registration sensor.
			<ul style="list-style-type: none"> <li>▪ Harness Disconnection at BCU</li> <li>▪ Controller board loose or broken</li> <li>▪ Defective BCU</li> <li>▪ Defective Controller Board</li> </ul>

**SC Tables: SC7xx**

720	B	3000-Sheet Finisher Error
-24	-	Finisher exit guide plate motor error
		<ul style="list-style-type: none"> <li>▪ The exit guide plate HP sensor does not detect the home position of the exit guide plate within the specified number of pulses after the exit guide plate has moved to its home position.</li> <li>▪ The exit guide plate HP sensor does not turn off within the specified number of pulses after the exit guide plate has moved from its home position.</li> </ul> <p>The 1st detection failure issues a jam error, and the 2nd failure issues this SC code.</p>
		<ul style="list-style-type: none"> <li>▪ Exit guide plate motor disconnected, defective</li> <li>▪ Exit guide plate motor harness is loose or broken</li> <li>▪ Exit guide plate HP sensor disconnected, defective</li> <li>▪ Exit guide plate HP sensor harness is loose or broken</li> <li>▪ Exit guide plate motor overloaded due to obstruction</li> </ul>
-25	-	Finisher punch motor error
		<ul style="list-style-type: none"> <li>▪ The punch HP sensor does not detect the home position of the punch unit within the specified number of pulses after the punch unit has moved to its home position.</li> <li>▪ The punch HP sensor does not turn off within the specified number of pulses after the punch unit has moved from its home position.</li> </ul> <p>The 1st detection failure causes a jam error, and the 2nd failure causes this SC code.</p>
		<ul style="list-style-type: none"> <li>▪ Punch motor disconnected or defective</li> <li>▪ Punch motor harness is loose or broken</li> <li>▪ Punch HP sensor disconnected, defective</li> <li>▪ Punch HP sensor harness is loose or broken</li> <li>▪ Punch motor overload due to obstruction</li> </ul>

-30	-	<p>Finisher jogger motor error</p>
		<ul style="list-style-type: none"> <li>▪ The jogger HP sensor does not detect the home position of the jogger fences within the specified number of pulses after the jogger fences have moved to its home position.</li> <li>▪ The jogger HP sensor does not turn off within the specified number of pulses after the jogger fences have moved from its home position.</li> </ul> <p>The 1st failure issues an original jam message, and the 2nd failure issues this SC code.</p>
		<ul style="list-style-type: none"> <li>▪ Jogger motor disconnected, defective</li> <li>▪ Jogger motor harness is loose or broken</li> <li>▪ Jogger HP sensor disconnected, defective</li> <li>▪ Jogger HP sensor harness is loose or broken</li> <li>▪ Jogger motor overloaded due to obstruction</li> <li>▪ Defective main board</li> </ul>
-41	-	<p>Stack feed-out motor error</p>
		<ul style="list-style-type: none"> <li>▪ The stack feed-out HP sensor does not detect the home position of the stack feed-out belt within the specified number of pulses after the stack feed-out belt has moved to its home position.</li> <li>▪ The stack feed-out HP sensor does not turn off within the specified number of pulses after the stack feed-out belt has moved from its home position.</li> </ul> <p>The 1st detection failure causes a jam error, and the 2nd failure causes this SC code.</p>
		<ul style="list-style-type: none"> <li>▪ Stack feed-out motor disconnected, defective</li> <li>▪ Stack feed-out motor harness is loose or broken</li> <li>▪ Stack feed-out HP sensor disconnected, defective</li> <li>▪ Stack feed-out HP sensor harness is loose or broken</li> <li>▪ Stack feed-out motor overloaded due to obstruction</li> <li>▪ Defective main board</li> </ul>

-42	-	Finisher stapler movement motor error
		<ul style="list-style-type: none"> <li>▪ The stapler HP sensor does not detect the home position of the stapler within the specified number of pulses after the stapler has moved to its home position.</li> <li>▪ The stapler HP sensor does not turn off within the specified number of pulses after the stapler has moved from its home position.</li> </ul> <p>The 1st detection failure causes a jam error, and the 2nd failure causes this SC code.</p> <ul style="list-style-type: none"> <li>▪ Stapler movement motor disconnected, defective</li> <li>▪ Stapler movement motor harness is loose or broken</li> <li>▪ Stapler HP sensor disconnected, defective</li> <li>▪ Stapler HP sensor harness is loose or broken</li> <li>▪ Stapler movement motor overloaded due to obstruction</li> </ul>
-43	-	Finisher corner stapler rotation motor error
		<ul style="list-style-type: none"> <li>▪ The corner stapler HP sensor does not detect the home position of the corner stapler within the specified number of pulses after the corner stapler has moved to its home position.</li> <li>▪ The corner stapler HP sensor does not turn off within the specified number of pulses after the corner stapler has moved from its home position.</li> </ul> <p>The 1st detection failure causes a jam error, and the 2nd failure causes this SC code.</p> <ul style="list-style-type: none"> <li>▪ Corner stapler rotation motor disconnected, defective</li> <li>▪ Corner stapler rotation motor harness is loose or broken</li> <li>▪ Corner stapler rotation HP sensor disconnected, defective</li> <li>▪ Corner stapler rotation HP sensor harness is loose or broken</li> <li>▪ Corner stapler rotation motor overloaded due to obstruction</li> </ul>

-44	-	Finisher corner stapler motor error
		<p>The 1st detection failure causes a jam error, and the 2nd failure causes this SC code.</p> <ul style="list-style-type: none"> <li>▪ The stapler motor does not switch off within the prescribed time after operating.</li> </ul>
-52	-	<ul style="list-style-type: none"> <li>▪ Staple jam</li> <li>▪ Corner stapler motor disconnected, defective</li> <li>▪ Corner stapler motor harness is loose or broken</li> <li>▪ Corner stapler HP sensor disconnected, defective</li> <li>▪ Corner stapler HP sensor harness is loose or broken</li> <li>▪ Corner stapler motor overloaded</li> </ul>
		<p>Finisher folder plate motor error</p> <ul style="list-style-type: none"> <li>▪ The folder plate HP sensor does not detect the home position of the folder plate within the specified number of pulses after the folder plate has moved to its home position.</li> <li>▪ The folder plate HP sensor does not turn off within the specified number of pulses after the folder plate has moved from its home position.</li> </ul> <p>The 1st detection failure causes a jam error, and the 2nd failure causes this SC code.</p>
		<ul style="list-style-type: none"> <li>▪ Folder plate motor disconnected, defective</li> <li>▪ Folder plate motor harness is loose or broken</li> <li>▪ Folder plate HP sensor disconnected, defective</li> <li>▪ Folder plate HP sensor harness is loose or broken</li> <li>▪ Folder plate motor overloaded due to obstruction</li> </ul>

-53	-	Folding unit bottom fence lift motor
		<ul style="list-style-type: none"> <li>▪ The folding unit bottom fence HP sensor does not detect the home position of the folding unit bottom fence within the specified number of pulses after the folding unit bottom fence has moved to its home position.</li> <li>▪ The folding unit bottom fence HP sensor does not turn off within the specified number of pulses after the folding unit bottom fence has moved from its home position.</li> </ul> <p>The 1st detection failure causes a jam error, and the 2nd failure causes this SC code.</p>
		<ul style="list-style-type: none"> <li>▪ Folding unit bottom fence motor disconnected, defective</li> <li>▪ Folding unit bottom fence motor harness is loose or broken</li> <li>▪ Folding unit bottom fence HP sensor disconnected, defective</li> <li>▪ Folding unit bottom fence HP sensor harness is loose or broken</li> <li>▪ Folding unit bottom fence motor overloaded due to obstruction</li> </ul>
-55	-	Clamp roller retraction motor error
		<ul style="list-style-type: none"> <li>▪ The clamp roller HP sensor does not detect the home position of the clamp roller cam within the specified number of pulses after the clamp roller cam has moved to its home position.</li> <li>▪ The clamp roller HP sensor does not turn off within the specified number of pulses after the clamp roller cam has moved from its home position.</li> </ul> <p>The 1st detection failure causes a jam error, and the 2nd failure causes this SC code.</p>
		<ul style="list-style-type: none"> <li>▪ Clamp roller retraction motor disconnected, defective</li> <li>▪ Clamp roller retraction motor harness is loose or broken</li> <li>▪ Clamp roller HP sensor disconnected, defective</li> <li>▪ Clamp roller HP sensor harness is loose or broken</li> <li>▪ Clamp roller retraction motor overloaded due to obstruction</li> </ul>

-57	-	Stack junction gate motor error
		<ul style="list-style-type: none"> <li>▪ The stack junction gate HP sensor does not detect the home position of the stack junction gate within the specified number of pulses after the stack junction gate has moved to its home position.</li> <li>▪ The stack junction gate HP sensor does not turn off within the specified number of pulses after the stack junction gate has moved from its home position.</li> </ul> <p>The 1st detection failure causes a jam error, and the 2nd failure causes this SC code.</p>
		<ul style="list-style-type: none"> <li>▪ Stack junction gate motor disconnected, defective</li> <li>▪ Stack junction gate motor harness is loose or broken</li> <li>▪ Stack junction gate HP sensor disconnected, defective</li> <li>▪ Stack junction gate HP sensor harness is loose or broken</li> <li>▪ Stack junction gate motor overloaded due to obstruction</li> </ul>
-60	-	Booklet stapler motor error 1
		<p>The 1st detection failure causes a jam error, and the 2nd failure causes this SC code.</p> <p>The front stapler unit saddle-stitch motor does not start operation within the specified time.</p>
		<ul style="list-style-type: none"> <li>▪ Staple jam</li> <li>▪ Front stapler motor disconnected, defective</li> <li>▪ Front stapler motor harness is loose or broken</li> <li>▪ Front stapler motor overloaded</li> </ul>
-61	-	Booklet staple motor error 2
		<p>The 1st detection failure causes a jam error, and the 2nd failure causes this SC code.</p> <p>The rear stapler unit saddle-stitch motor does not start operation within the specified time.</p>
		<ul style="list-style-type: none"> <li>▪ Staple jam</li> <li>▪ Rear stapler motor disconnected, defective</li> <li>▪ Rear stapler motor harness is loose or broken</li> <li>▪ Rear stapler motor overloaded</li> </ul>

-70	-	Tray lift motor error
		The upper tray paper height sensor does not change its status with the specified time after the tray raises or lowers. The 1st detection failure causes a jam error, and the 2nd failure causes this SC code.
		<ul style="list-style-type: none"> <li>▪ Tray lift motor disconnected, defective</li> <li>▪ Tray lift motor harness is loose or broken</li> <li>▪ Upper tray paper height sensor disconnected, defective</li> <li>▪ Upper tray paper height sensor is loose or broken</li> <li>▪ Tray lift motor overloaded due to obstruction</li> </ul>
-71	-	Finisher Tray 1 shift motor error
		<ul style="list-style-type: none"> <li>▪ The shift roller HP sensor does not detect the home position of the upper tray within the specified number of pulses after the upper tray has moved to its home position.</li> <li>▪ The shift roller HP sensor does not turn off within the specified number of pulses after the upper tray has moved from its home position.</li> </ul> <p>The 1st detection failure issues a jam error, and the 2nd failure issues this SC code.</p>
		<ul style="list-style-type: none"> <li>▪ Shift tray motor disconnected, defective</li> <li>▪ Shift tray motor harness is loose or broken</li> <li>▪ Shift tray HP sensor disconnected, defective</li> <li>▪ Shift tray HP sensor is loose or broken</li> <li>▪ Shift tray motor overloaded due to obstruction</li> </ul>
-72	-	Shift jogger motor 1 error
		The side fence does not retract within the specified number of pulses after the shift jogger motor 1 switches on. The 1st detection failure issues a jam error, and the 2nd failure issues this SC code.
		<ul style="list-style-type: none"> <li>▪ Shift jogger motor 1 disconnected, defective</li> <li>▪ Shift jogger motor 1 harness is loose or broken</li> <li>▪ Shift jogger 1 HP sensor disconnected, defective</li> <li>▪ Shift jogger 1 HP sensor harness is loose or broken</li> <li>▪ Shift jogger motor 1 overloaded due to obstruction</li> </ul>



Service Call Conditions

-73	-	Shift jogger motor 2 error
		<p>The side fence does not retract within the specified number of pulses after the shift jogger motor 2 switches on.</p> <p>The 1st detection failure issues a jam error, and the 2nd failure issues this SC code.</p>
		<ul style="list-style-type: none"> <li>▪ Shift jogger motor 2 disconnected, defective</li> <li>▪ Shift jogger motor 2 harness is loose or broken</li> <li>▪ Shift jogger 2 HP sensor disconnected, defective</li> <li>▪ Shift jogger 2 HP sensor harness is loose or broken</li> <li>▪ Shift jogger motor 2 overloaded due to obstruction</li> </ul>
-74	-	Shift jogger retraction motor error
		<p>The side fences do not retract within the specified number of pulses after the retraction motor switches on.</p> <p>The 1st detection failure issues a jam error, and the 2nd failure issues this SC code.</p>
		<ul style="list-style-type: none"> <li>▪ Shift jogger retraction motor disconnected, defective</li> <li>▪ Shift jogger retraction motor harness is loose or broken</li> <li>▪ Shift jogger retraction HP sensor disconnected, defective</li> <li>▪ Shift jogger retraction HP sensor harness is loose or broken</li> <li>▪ Shift jogger retraction motor 2 overloaded due to obstruction</li> </ul>
-75	-	Return roller motor error
		This occurs during the operation of the lower tray pressure motor.
		<ul style="list-style-type: none"> <li>▪ Motor disconnected, defective</li> <li>▪ Motor harness disconnected, defective</li> <li>▪ Home position sensor disconnected, defective</li> <li>▪ Home position sensor harness disconnected, defective</li> <li>▪ Motor overloaded due to obstruction</li> </ul>

-80	-	Punch movement motor error
		<ul style="list-style-type: none"> <li>▪ The punch movement HP sensor does not detect the home position of the punch unit within the specified number of pulses after the punch unit has moved to its home position.</li> <li>▪ The punch movement HP sensor does not turn off within the specified number of pulses after the punch unit has moved from its home position.</li> </ul> <p>The 1st detection failure causes a jam error, and the 2nd failure causes this SC code.</p>
		<ul style="list-style-type: none"> <li>▪ Punch movement motor disconnected, defective</li> <li>▪ Punch movement motor harness is loose or broken</li> <li>▪ Punch movement motor overloaded due to obstruction</li> </ul>
-81	-	Paper position sensor slide motor error
		<p>The paper position sensor moves but is not detected at the home position within the specified number of pulses.</p> <p>The 1st detection failure causes a jam error, and the 2nd failure causes this SC code.</p>
		<ul style="list-style-type: none"> <li>▪ Paper position sensor slide motor harness disconnected, defective</li> <li>▪ Paper position sensor slide motor harness is loose or broken</li> <li>▪ Paper position sensor slide motor overloaded due to obstruction</li> </ul>

722	B	1000-Sheet Finisher Error
-10	-	Upper transport motor error
		The upper transport motor in the finisher is not operating.
		<ul style="list-style-type: none"> <li>▪ The motor harness is loose or broken</li> <li>▪ Upper transport motor disconnected, defective</li> <li>▪ Upper transport motor overloaded due to obstruction (jammed paper, paper scraps, etc.)</li> </ul>

Service Call Conditions

-14	-	Lower transport motor error
		The lower transport motor in the finisher is not operating.
		<ul style="list-style-type: none"> <li>▪ The motor harness is loose or broken</li> <li>▪ Lower transport motor disconnected, defective</li> <li>▪ Lower transport motor drive overloaded due to obstruction (jammed paper, paper scraps, etc.)</li> </ul>
-17	-	Exit motor error
		The exit motor in the finisher is not operating.
		<ul style="list-style-type: none"> <li>▪ The motor harness is loose or broken</li> <li>▪ Exit motor disconnected, defective</li> <li>▪ Exit motor drive overloaded due to obstruction (jammed paper, paper scraps, etc.)</li> </ul>
-24	-	Finisher exit guide plate motor error
		<ul style="list-style-type: none"> <li>▪ The exit guide plate HP sensor does not detect the home position of the exit guide plate within the prescribed time after the exit guide plate has moved to its home position.</li> <li>▪ The exit guide plate HP sensor does not turn off within the prescribed time after the exit guide plate has moved from its home position.</li> </ul> <p>The 1st detection failure issues a jam error, and the 2nd failure issues this SC code.</p>
		<ul style="list-style-type: none"> <li>▪ Exit guide plate motor harness loose, broken</li> <li>▪ Exit guide plate HP sensor harness loose, broken</li> <li>▪ Exit guide plate motor disconnected, defective</li> <li>▪ Exit guide plate HP sensor disconnected, defective</li> <li>▪ Finisher exit guide plate motor drive overloaded due to obstruction (jammed paper, paper scraps, etc.)</li> </ul>

-30	-	Jogger fence motor error
		<ul style="list-style-type: none"> <li>▪ The jogger HP sensor does not detect the home position of the jogger fences within the prescribed time after the jogger fences have moved to its home position.</li> <li>▪ The jogger HP sensor does not turn off within the prescribed time after the jogger fences have moved from its home position.</li> </ul> <p>The 1st failure issues an original jam message, and the 2nd failure issues this SC code.</p>
		<ul style="list-style-type: none"> <li>▪ The motor harness is loose or broken</li> <li>▪ Jogger fence HP sensor harness loose, broken</li> <li>▪ Jogger fence motor disconnected, defective</li> <li>▪ Jogger fence HP sensor disconnected, defective</li> <li>▪ Jogger motor drive overloaded due to obstruction (jammed paper, paper scraps, etc.)</li> </ul>
-41	-	Feed-out belt motor error
		<ul style="list-style-type: none"> <li>▪ The feed-out HP sensor does not detect the home position of the feed-out belt within the prescribed time after the feed-out belt has moved to its home position.</li> <li>▪ The feed-out HP sensor does not turn off within the prescribed time after the feed-out belt has moved from its home position.</li> </ul> <p>The 1st detection failure causes a jam error, and the 2nd failure causes this SC code.</p>
		<ul style="list-style-type: none"> <li>▪ Feed-out belt motor harness loose or broken</li> <li>▪ Feed-out belt HP sensor harness loose or broken</li> <li>▪ Feed-out belt motor disconnected, defective</li> <li>▪ Feed-out belt HP sensor disconnected, defective</li> <li>▪ Feed-out belt motor drive overloaded due to obstruction (jammed paper, paper scraps, etc.)</li> </ul>

-42	-	<p>Stapler movement motor</p>
		<ul style="list-style-type: none"> <li>▪ The stapler HP sensor does not detect the home position of the stapler within the prescribed time after the stapler has moved to its home position.</li> <li>▪ The stapler HP sensor does not turn off within the prescribed time after the stapler has moved from its home position.</li> </ul> <p>The 1st detection failure issues a jam error, and the 2nd failure causes this SC code.</p>
		<ul style="list-style-type: none"> <li>▪ Stapler movement motor harness loose or broken</li> <li>▪ Stapler HP sensor harness loose, broken</li> <li>▪ Stapler movement motor disconnected, defective</li> <li>▪ Stapler HP sensor disconnected, defective</li> <li>▪ Stapler or motor drive overloaded due to obstruction (jammed paper, paper scraps, etc.)</li> </ul>
-44	-	<p>Corner stapler motor error</p>
		<ul style="list-style-type: none"> <li>▪ The corner stapler motor does not switch off within the prescribed time after operating.</li> <li>▪ The corner stapler HP sensor does not detect the home position of the corner stapler within the prescribed time after the corner stapler has moved to its home position.</li> <li>▪ The corner stapler HP sensor does not turn off within the prescribed time after the corner stapler has moved from its home position.</li> </ul> <p>The 1st detection failure issues a jam error, and the 2nd failure causes this SC code.</p>
		<ul style="list-style-type: none"> <li>▪ Staple jam</li> <li>▪ Corner stapler motor disconnected, defective</li> <li>▪ Corner stapler motor harness is loose or broken</li> <li>▪ Corner stapler HP sensor disconnected, defective</li> <li>▪ Number of sheets in stack exceeds allowed number of sheets for stapling</li> <li>▪ Stapler motor obstructed</li> </ul>

-70	-	Tray lift motor error
		The upper tray paper height sensor does not change its status with the specified time after the tray raises or lowers. The 1st detection failure causes a jam error, and the 2nd failure causes this SC code.
		<ul style="list-style-type: none"> <li>▪ Tray lift motor disconnected, defective</li> <li>▪ Tray lift motor harness is loose or broken</li> <li>▪ Stack height sensor disconnected, defective</li> <li>▪ Tray lift motor overloaded due to obstruction (jammed paper, paper scraps, etc.)</li> </ul>
-71	-	Shift tray motor error
		<ul style="list-style-type: none"> <li>▪ The shift roller HP sensor does not detect the home position of the upper tray within the specified number of pulses after the upper tray has moved to its home position.</li> <li>▪ The shift roller HP sensor does not turn off within the specified number of pulses after the upper tray has moved from its home position.</li> </ul> <p>The 1st detection failure issues a jam error, and the 2nd failure issues this SC code.</p>
		<ul style="list-style-type: none"> <li>▪ Shift tray motor disconnected, defective</li> <li>▪ Shift tray motor harness is loose or broken</li> <li>▪ Shift tray HP sensor disconnected, defective</li> <li>▪ Shift tray motor overloaded due to obstruction (jammed paper, paper scraps, etc.)</li> </ul>
770	B	Shift motor error
		The shift motor HP sensor does not detect any change for 1.86 seconds after the shift motor has turned on at power on or during its operation.
		<ul style="list-style-type: none"> <li>▪ Defective shift motor</li> <li>▪ Defective shift motor HP sensor</li> </ul>

Trouble-shooting

Service Call Conditions

791	D	Bridge unit error
		The machine recognizes the finisher, but does not recognize the bridge unit.
		<ul style="list-style-type: none"><li>▪ Bridge unit is not installed</li><li>▪ Bridge unit is installed incorrectly</li><li>▪ Defective bridge unit</li></ul>

792	B	Finisher error
		The machine does not recognize the bridge unit finisher, but recognizes the bridge unit.
		<ul style="list-style-type: none"><li>▪ Poor finisher connector connections</li><li>▪ Finisher is not installed although the bridge unit is installed on the machine</li><li>▪ Defective finisher</li></ul>

**SC Tables: SC8xx**

816	D	Energy save I/O sub-system error
		Energy saver sub-system detects an error.
		<ul style="list-style-type: none"> <li>▪ Defective controller board</li> </ul>
-01	-	Sub-system error
-03	-	STR denied error
-04	-	Kernel communication driver error
-05	-	STR preprocessing error
-13	-	open () error
-14	-	Memory address designation error
-15 to -18	-	open () error
-19	-	double open () error
-20	-	open () error
-22	-	Parameter error
-23 to -24	-	read () error
-25	-	write () error
-26 to -28	-	write () communication retry error
-29 to -30	-	read () communication retry error



## Service Call Conditions

-36 to -94	-	Sub-system error
------------------	---	------------------

817	C	Monitor Error
		This is a file detection and electronic file signature check error when the boot loader attempts to read the self-diagnostic module, system kernel, or root system files from the OS Flash ROM, or the items on the SD card in the controller slot are false or corrupted.
		<ul style="list-style-type: none"> <li>▪ OS Flash ROM data defective; change the controller firmware</li> <li>▪ SD card data defective; use another SD card</li> </ul>

818	C	Watchdog timer error
		The watchdog timer detect the error even if system processing normally.
		<ul style="list-style-type: none"> <li>▪ System program defective</li> <li>▪ Controller board defective</li> <li>▪ Optional board defective</li> </ul>

819	C	Fatal kernel error	
		Due to a control error, a RAM overflow occurred during system processing. One of the following messages was displayed on the operation panel.	
		0x6261	6261 6420 6469 7200 00 -> "bad dir"
		0x696e	0x69742064 -> "init died"
		0x766d	0x5f706167 -> "vm_pageout: VM is full"
		554C	UL (USB error)
		----	Error in the OS
			"init died", "vm_pageout: VM is full", "Cache Error"
			<ul style="list-style-type: none"> <li>▪ System program defective</li> <li>▪ Controller board defective</li> <li>▪ Optional board defective</li> <li>▪ Replace controller firmware</li> </ul>

**Note**

- For more details about this SC code error, execute SP5990 to print an SMC report so you can read the error code. The error code is not displayed on the operation panel.

820	C	Self-diagnostics error: CPU [XXXX]: Detailed error code
[0001] to [06FF] [0801] to [4005]		CPU error During the self-diagnostic, the controller CPU detects an error. There are 47 types of error code (0001 to 4005) depending on the cause of the error. The CPU detects an error and displays the specific error code with the program address where the error occurs.
		<ul style="list-style-type: none"> <li>▪ System firmware problem</li> <li>▪ Defective controller</li> </ul>
		<ol style="list-style-type: none"> <li>1. Turn the main switch off and on.</li> <li>2. Reinstall the controller system firmware.</li> <li>3. Replace the controller.</li> </ol> <p>When the problem cannot be fixed with the above procedure, the following information displayed on the screen needs to be fed back to a technical support center.</p> <ul style="list-style-type: none"> <li>▪ SC code</li> <li>▪ Detailed error code</li> <li>▪ Program address</li> </ul>
[0701] to [070A]		CPU/Memory Error
		<ul style="list-style-type: none"> <li>▪ System firmware problem</li> <li>▪ Defective RAM-DIMM</li> <li>▪ Defective controller</li> </ul>
		<ol style="list-style-type: none"> <li>1. Reinstall the controller system software.</li> <li>2. Replace the RAM-DIMM.</li> <li>3. Replace the controller.</li> </ol>

821	C	Self-diagnostics error: ASIC [XXXX]: Detailed error code
[0B00]		ASIC error
		The write-&-verify check error has occurred in the ASIC.
		<ul style="list-style-type: none"> <li>▪ Defective ASIC device</li> </ul> Replace the controller board.
[0D05]		Self-diagnosis error: ASIC
		The CPU checks if the ASIC timer works correctly compared with the CPU timer. If the ASIC timer does not function in the specified range, this SC code is displayed.
		<ul style="list-style-type: none"> <li>▪ System firmware problem</li> <li>▪ Defective RAM-DIMM</li> <li>▪ Defective controller</li> </ul> Replace the controller board.
[50A1]		Video bridge device (ASIC) error 1
		The CPU does not detect the video bridge device.
		<ul style="list-style-type: none"> <li>▪ Defective I/F between the video bridge device and controller</li> </ul>
[50A2]		Video bridge device (ASIC) register error 1
		The CPU detects the video bridge device, but detects error data from the video bridge device.
		<ul style="list-style-type: none"> <li>▪ Defective I/F between the video bridge device and controller</li> </ul>

**Note**

- For more details about this SC code error, execute SP5990 to print an SMC report so you can read the error code. The error code is not displayed on the operation panel.

Service Call Conditions

822	B	Self-diagnostic error: HDD [XXXX]: Detailed error code
[3003]		Check performed only when HDD is installed: <ul style="list-style-type: none"> <li>HDD device busy for over 31 s.</li> <li>After a diagnostic command is set for the HDD, but the device remains busy for over 6 s.</li> </ul>
		<ul style="list-style-type: none"> <li>HDD defective</li> <li>HDD harness disconnected, defective</li> </ul>
[3004]		No response to the self-diagnostic command from the ASIC to the HDDs.
		<ul style="list-style-type: none"> <li>HDD defective</li> </ul>

823	B	Self-diagnostic error: NIB [XXXX]: Detailed error code
[6101]		MAC address check sum error The result of the MAC address check sum does not match the check sum stored in ROM.
[6104]		PHY IC error The PHY IC on the controller cannot be correctly recognized.
[6105]		PHY IC loop-back error An error occurred during the loop-back test for the PHY IC on the controller.

824	C	Self-diagnostic error : NVRAM
		NVRAM device does not exist, NVRAM device is damaged, or NVRAM socket damaged.
		<ul style="list-style-type: none"> <li>NVRAM defective</li> <li>Controller board defective</li> <li>NVRAM backup battery exhausted</li> <li>NVRAM socket damaged</li> </ul>

826	C	Self-diagnostic Error: RTC/optional NVRAM
[1501]	The one second counted by the RTC is different from the one second counted by the CPU on the controller.	
	<ul style="list-style-type: none"> <li>▪ Defective RTC device</li> </ul>	
[15FF]	The RTC device is not detected.	
	<ul style="list-style-type: none"> <li>▪ Defective RTC device</li> <li>▪ NVRAM without RTC installed</li> <li>▪ Discharged backup battery</li> </ul>	

827	C	Self-diagnostic error: Standard SDRAM DIMM [XXXX]: Detailed error code
[0201]	Verification error	
	Error detected during a write/verify check for the standard RAM (SDRAM DIMM).	
	<ul style="list-style-type: none"> <li>▪ Loose connection</li> <li>▪ Defective SDRAM DIMM</li> <li>▪ Defective controller</li> </ul>	
[0202]	Resident memory error	
	The SPD values in all RAM DIMM are incorrect or unreadable.	
	<ul style="list-style-type: none"> <li>▪ Defective RAM DIMM</li> <li>▪ Defective SPD ROM on RAM DIMM</li> <li>▪ Defective 12C bus</li> </ul>	
	Replace the RAM DIMM.	

Service Call Conditions

828	C	Self-diagnostic error: ROM [XXXX]: Detailed error code
[0101]		<p>Check sum error 1</p> <ul style="list-style-type: none"> <li>▪ The boot monitor and OS program stored in the ROM DIMM is checked. If the check sum of the program is incorrect, this SC code is displayed.</li> </ul>
		<p>1. Replace the controller board.</p>

829	B	Self-diagnostic error: Optional RAM [XXXX]: Detailed error code
[0301]		Verification error
		Error detected during a write/verify check for the optional RAM (SDRAM DIMM).
		<ul style="list-style-type: none"> <li>▪ Loose connection</li> <li>▪ Defective SDRAM DIMM</li> <li>▪ Defective controller</li> </ul>
		<p>Turn the main switch off and on. Replace the SDRAM DIMM. Replace the controller.</p>
[0302]		Memory structure data error
		The memory structure data error for the optional RAM (SDRAM DIMM) is detected when the self-diagnostic is executed.
		<ul style="list-style-type: none"> <li>▪ Defective RAM DIMM</li> <li>▪ Defective SPD ROM on RAM DIMM</li> <li>▪ Defective 12C bus</li> </ul>
		Replace the RAM DIMM.

833	C	Self-diagnostic error 8: Engine I/F ASIC
[0F30] [0F31]		ASIC (Mandolin) for system control could not be detected. After the PCI configuration, the device ID for the ASIC could not be checked. Replace the bridge board.
[0F41]		ASIC (Mandolin) for system control could not be detected. After the PCI configuration, the device ID for the ASIC could not be checked. Replace the bridge board.
[50B1]		Could not initialize or read the bus connection. Check for loose connections at the mother board. Replace the bridge board.
[50B2]		Value of the SSCG register is incorrect. Check for loose connections at the mother board. Replace the bridge board.

835	B	Self-diagnostic error: Centronic device
[1102]		Loopback connector is connected but check results in an error. <ul style="list-style-type: none"> <li>▪ IEEE1284 connector error</li> <li>▪ Centronic loopback connector defective</li> </ul> Replace the controller board.
[110C]		Loopback connector is connected but check results in an error. <ul style="list-style-type: none"> <li>▪ ASIC device error</li> <li>▪ IEEE1284 connector error</li> <li>▪ Centronic loopback connector defective</li> </ul> Replace the controller board.



## Service Call Conditions

[1120]	Centronic loopback connector is not connected for detailed self-diagnostic test.	
	<ul style="list-style-type: none"> <li>▪ Centronic loopback connector not connected correctly</li> <li>▪ Centronic loopback connector defective</li> <li>▪ ASIC device defective</li> </ul>	
	Replace the controller board.	

838	C	Self-diagnostic Error: Clock Generator
[2701]	A verify error occurred when setting data was read from the clock generator via the I2C bus.	
	<ul style="list-style-type: none"> <li>▪ Defective clock generator</li> <li>▪ Defective I2C bus</li> <li>▪ Defective I2C port on the CPU</li> </ul>	
	Replace the controller board.	

839	C	USB NAND Flash ROM error
[9001]	USB NAND Flash ROM cannot be read.	
	<ul style="list-style-type: none"> <li>▪ Defective controller board</li> </ul>	
[9101]	The ID of the USB NAND Flash ROM cannot be read.	
	<ul style="list-style-type: none"> <li>▪ Defective controller board</li> </ul>	
[9110]	The USB NAND Flash ROM controller is disconnected.	
	<ul style="list-style-type: none"> <li>▪ Defective controller board</li> </ul>	

840	D	EEPROM error 1: EEPROM access
		<ul style="list-style-type: none"> <li>▪ During the I/O processing, a reading error occurred. The 3<sup>rd</sup> reading failure causes this SC code.</li> <li>▪ During the I/O processing, a writing error occurred.</li> </ul>
		Defective EEPROM

841	D	EEPROM reading error
		Mirrored data of the EEPROM is different from the original data in EEPROM.
		Data in the EEPROM is overwritten for some reason.

842	C	Nand-Flash update VerifyError
		SCS detected abnormal writing (verifying Error) in the module which is written in Nand-Flash on the time of ROM remote update or ROM update.
		<p><b>Note</b></p> <ul style="list-style-type: none"> <li>▪ This SC is logged at 1<sup>st</sup> error detection. SC819 is issued at 2<sup>nd</sup> error detection.</li> <li>▪ SC819 is issued at 2<sup>nd</sup> error detection.</li> </ul>
		Defective Nand-Flash (controller board)

851	B	IEEE 1394 I/F error
		Driver setting incorrect and cannot be used by the 1394 I/F.
		<p><b>Not supported by this machine</b></p> <ul style="list-style-type: none"> <li>▪ NIB (PHY), LINK module defective; change the Interface Board</li> <li>Controller board defective</li> </ul>

853	B	Wireless LAN Error 1
		During machine operation, the Wireless LAN device (Bluetooth) is inserted into the controller board.
		<p><b>Not supported by this machine</b></p> <ul style="list-style-type: none"> <li>▪ During machine operation, the Wireless LAN device (Bluetooth) is inserted into the controller board.</li> </ul>

Service Call Conditions

854	B	Wireless LAN Error 2
		During machine operation, the Wireless LAN device (Bluetooth) is pulled out from the controller board.
		<p><b>Not supported by this machine</b></p> <ul style="list-style-type: none"> <li>▪ During machine operation, the Wireless LAN device (Bluetooth) is pulled out from the controller board.</li> </ul>

855	B	Wireless LAN error
		An error is detected on the wireless LAN card (802.11a/g, g).
		<ul style="list-style-type: none"> <li>▪ Wireless LAN card defective</li> <li>▪ Wireless LAN card connection incorrect</li> </ul>

857	B	USB I/F Error
		The USB driver is not stable and caused an error.
		<ul style="list-style-type: none"> <li>▪ Bad USB card connection</li> </ul> <p>Replace the controller board</p>

858	A	HDD Encryption unit error 1
		A serious error occurs when data is encrypted to update an encryption key with the HDD encryption unit.
-00	-	Encryption key acquisition error: The controller fails to get a new encryption key.
		<ul style="list-style-type: none"> <li>▪ Defective controller board</li> </ul> <p>Replace the controller board.</p>
-01	-	Encryption key setting for HDD error: The controller fails to copy a new encryption key to the HDD.
		<ul style="list-style-type: none"> <li>▪ Defective SATA chip on the controller board</li> </ul> <p>Replace the controller board.</p>

-02	-	NVRAM data encryption error 1: An error occurs while the NVRAM data is encrypted.
		<ul style="list-style-type: none"> <li>▪ Defective NVRAM on the controller board</li> </ul> Replace the NVRAM.
-30	-	NVRAM data encryption error 2: An error occurs before the NVRAM data is encrypted.
		<ul style="list-style-type: none"> <li>▪ Defective controller board</li> </ul> Replace the controller board.
-31	-	Other error: A serious error occurs while the data is encrypted.
		<ul style="list-style-type: none"> <li>▪ Same as SC991</li> </ul>

859	B	HDD Encryption unit error 2
		A serious error occurs when the HDD data is encrypted to update an encryption key with the HDD encryption unit.
-01	-	HDD check error: The HDD is not correctly installed.
		<ul style="list-style-type: none"> <li>▪ No HDD installed</li> <li>▪ Unformatted HDD</li> <li>▪ The encryption key on the controller is different from the one on the HDD</li> </ul> 1. Install the HDD correctly. 2. Initialize the HDD.
-02	-	Power failure during the data encryption: The data encryption (NVRAM and HDD) has not been completed.
		<ul style="list-style-type: none"> <li>▪ Power failure during the data encryption</li> </ul> Initialize the HDD.
-10	-	Data read/write error: The DMAC error is detected twice or more.
		<ul style="list-style-type: none"> <li>▪ Same as SC863</li> </ul>

Service Call Conditions

860	B	HDD startup error at main power on
		<ul style="list-style-type: none"> <li>▪ HDD is connected but a driver error is detected.</li> <li>▪ The driver does not respond with the HDD within 30 s.</li> </ul>
		<ul style="list-style-type: none"> <li>▪ HDD is not initialized</li> <li>▪ Label data is corrupted</li> <li>▪ Defective HDD</li> </ul> <p>Initialize the HDD with SP5832-001.</p>

861	D	HDD re-try failure
		<p>At power on, the HDD is detected. Power supply to the HDD is interrupted after the system has entered the energy save mode, but after the HDD has been awakened from the energy save mode, it does not return to the ready status within 30 sec.</p>
		<ul style="list-style-type: none"> <li>▪ Harness between HDD and controller board disconnected, defective</li> <li>▪ HDD power connector disconnected</li> <li>▪ HDD defective</li> <li>▪ Controller board defective</li> </ul>

862	D	Bad sector number error
		The number of bad sectors in the HDD (image data area) goes over 101.
		<ul style="list-style-type: none"> <li>▪ Defective HDD</li> </ul>
		<p>Format the HDD with SP5832-001. Replace the HDD.</p>

863	D	HDD data read failure	
-	-	<p>The data written to the HDD cannot be read normally, due to bad sectors generated during operation.</p> <p><b>Note:</b> [001] to [023] indicate the type of partition where the error occurred.</p>	
		[001]	An area which does not belong to a partition
		[002]	a partition

		[003]	b partition
		[004]	c partition
		[005]	d partition
		[006]	e partition
		[007]	f partition
		[008]	g partition
		[009]	h partition
		[010]	l partition
		[011]	j partition
		[012]	k partition
		[013]	l partition
		[014]	m partition
		[015]	n partition
		[016]	o partition
		[017]	p partition
		[018]	q partition
		[019]	r partition
-	-	[020]	s partition
		[021]	q partition
		[022]	t partition
		[023]	u partition
		<ul style="list-style-type: none"> <li>▪ HDD defective</li> </ul> <p><b>Note:</b> If the bad sectors are generated at the image partition, the bad sector information is written to NVRAM, and the next time the HDD is accessed, these bad sectors will not be accessed for read/write operation.</p>	

Trouble-shooting

864	D	HDD data CRC error	
-	-	During HDD operation, the HDD cannot respond to a CRC error query. Data transfer does not execute normally while data is being written to the HDD. <b>Note:</b> [001] to [023] indicate the type of partition where the error occurred.	
		[001]	An area which does not belong to a partition
		[002]	a partition
		[003]	b partition
		[004]	c partition
		[005]	d partition
		[006]	e partition
		[007]	f partition
		[008]	g partition
		[009]	h partition
		[010]	l partition
		[011]	j partition
		[012]	k partition
		[013]	l partition
		[014]	m partition
		[015]	n partition
		[016]	o partition
		[017]	p partition
		[018]	q partition
		[019]	r partition
-	-	[020]	s partition
		[021]	q partition
		[022]	t partition

		[023]	u partition
		<ul style="list-style-type: none"> <li>▪ HDD defective</li> </ul>	

865	D	HDD access error	
		<p>HDD responded to an error during operation for a condition other than those for SC863, 864.</p> <p><b>Note:</b> [001] to [023] indicate the type of partition where the error occurred.</p>	
		[001]	An area which does not belong to a partition
		[002]	a partition
		[003]	b partition
		[004]	c partition
		[005]	d partition
		[006]	e partition
		[007]	f partition
		[008]	g partition
		[009]	h partition
		[010]	l partition
		[011]	j partition
		[012]	k partition
		[013]	l partition
		[014]	m partition
		[015]	n partition
		[016]	o partition
		[017]	p partition
		[018]	q partition
		[019]	r partition

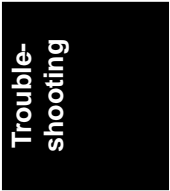



Service Call Conditions

-	-	[020]	s partition
		[021]	q partition
		[022]	t partition
		[023]	u partition
		<ul style="list-style-type: none"> <li>▪ HDD defective.</li> </ul>	

866	B	SD card error 1: Confirmation	
		<p>The machine detects an electronic license error in the application on the SD card in the controller slot immediately after the machine is turned on. The program on the SD card contains electronic confirmation license data. If the program does not contain this license data, or if the result of the check shows that the license data in the program on the SD card is incorrect, then the checked program cannot execute and this SC code is displayed.</p>	
		<ul style="list-style-type: none"> <li>▪ Program missing from the SD card</li> <li>▪ Download the correct program for the machine to the SD card</li> </ul>	

867	D	SD card error 2: SD card removed	
		<ul style="list-style-type: none"> <li>▪ The SD card in the slot is removed while the machine is on.</li> </ul>	
		<p>Insert the SD card, then turn the machine off and on.</p>	

868	D	SD card error 3: SC card access	
001, 002	<p>An error occurs while an SD card is used.</p>		
	<ul style="list-style-type: none"> <li>▪ SD card not inserted correctly</li> <li>▪ SD card defective</li> <li>▪ Controller board defective</li> </ul> <p><b>Note:</b> If you want to try to reformat the SC card, use SD Formatter Ver 1.1.</p>		

870	B	Address book data error
		The address book data cannot be read from the HDD, SD card or flash ROM on the controller where it is stored, or the data read from the media is defective.
		<ul style="list-style-type: none"> <li>▪ Software defective: Turn the machine off/on. If this is not the solution for the problem, then replace the controller firmware.</li> <li>▪ Data corruption</li> <li>▪ HDD defective.</li> </ul>
		<b>More Details</b>
		<ol style="list-style-type: none"> <li>1. Do SP5846-046 (Initialize All Setting &amp; Addr Book) to reset all address book data.</li> <li>2. Reset the user information with SP5832-001 (HDD – HDD Formatting (All)).</li> <li>3. Replace the HDD.</li> <li>4. If there is the address book data backed up with SD card, restore the address book data. Configure the same address book encryption key as the one configured when backing up.</li> </ol>

872	B	HDD mail receive data error
		<ul style="list-style-type: none"> <li>▪ The machine detects that the HDD is not operating correctly at power on.</li> <li>▪ The machine detects that the HDD is not operating correctly (can neither read nor write) while processing incoming email.</li> </ul>
		<ul style="list-style-type: none"> <li>▪ HDD defective</li> <li>▪ The machine is turned off while the HDD is being accessed.</li> </ul> <p>Do SP5832-001 to format the all data on the HDD.</p>

Service Call Conditions

873	B	HDD mail send data error	
		An error is detected on the HDD immediately after the machine has been turned on, or power has been turned off while the machine has used the HDD.	
		1. Do SP5832-001 (HDD – HDD Formatting (All)) to initialize the HDD. Replace the HDD	

874	D	Delete All error 1: HDD	
		A data error is detected for the HDD/NVRAM after the Delete All option has been used. <b>Note:</b> The source of this error is the DataOverwriteSecurity module.	
		1. Turn the main switch off/on and try the operation again. 2. HDD defective	

875	D	Delete All error 2: Data area	
		An error occurs while the machine deletes data from the HDD.	
		-001	An error occurs in hddchack-i.
		-002	Failed to delete data from the HDD.
		Turn the main switch off/on and try the operation again	

876	D	Log Data Error	
		An error is detected in the handling of the log data at power on or during machine operation. This can be caused by switching the machine off while it is operating.	
-01	-	Log Data Error 1	
		<ul style="list-style-type: none"> <li>▪ Damaged log data file in the HDD</li> </ul>	
		Initialize the HDD with SP5832-001.	

-02	-	Log Data Error 2
		<ul style="list-style-type: none"> <li>▪ An encryption module not installed</li> </ul>
		<ol style="list-style-type: none"> <li>1. Disable the log encryption setting with SP9730-004 ("0" is off.)</li> <li>2. Install the DESS module.</li> </ol>
-03	-	Log Data Error 3
		<ul style="list-style-type: none"> <li>▪ Invalid log encryption key due to defective NVRAM data</li> </ul>
		<ol style="list-style-type: none"> <li>1. Initialize the HDD with SP5832-001.</li> <li>2. Disable the log encryption setting with SP9730-004 ("0" is off.)</li> </ol>
-04	-	Log Data Error 4
		<ul style="list-style-type: none"> <li>▪ Unusual HDD encryption function due to defective NVRAM data</li> </ul>
		Initialize the HDD with SP5832-001.
-05	-	Log Data Error 5
		<ul style="list-style-type: none"> <li>▪ Installed a NVRAM or HDD which was used in another machine</li> </ul>
		<ol style="list-style-type: none"> <li>1. Reinstall the previous NVRAM or HDD.</li> <li>2. Initialize the HDD with SP5832-001.</li> </ol>
-99	-	Log Data Error 99
		<ul style="list-style-type: none"> <li>▪ Other than the above causes</li> </ul>
		Ask your supervisor.

Service Call Conditions

878	D	USB Flash Error
-00	-	TPM system authentication error
		The system firmware is not authenticated by TPM (security chip).
		<ul style="list-style-type: none"> <li>▪ Incorrect updating for the system firmware</li> <li>▪ Defective flash ROM on the controller board</li> </ul>
		Replace the controller board.
-01	-	USB Flash Error
		File system in the USB flash device is defective.
		<ul style="list-style-type: none"> <li>▪ Cannot mount partition 3 in the USB flash device.</li> <li>▪ Encryption key does not exist.</li> <li>▪ Cannot find the file for KMMD to be operated.</li> </ul>
		Replace the controller board.
-02	-	TPM Error
		An error occurred in TPM or in TPM driver.
		<ul style="list-style-type: none"> <li>▪ TPM defective</li> </ul>
		Replace the controller board.
-03	-	TCSD Error
		An error occurred in TPM or in TPM driver.
		<ul style="list-style-type: none"> <li>▪ TPM defective</li> </ul>
		Replace the controller board.

881	D	Authentication area error
-01	-	Authentication application error is detected.
		<ul style="list-style-type: none"> <li>▪ Error data in an authentication application reaches the management limit.</li> </ul>

899	D	Software performance error
		If the processing program shows abnormal performance and the program is abnormally ended, this SC is issued.
		<ul style="list-style-type: none"> <li>▪ Controller board defective</li> <li>▪ Software defective</li> </ul>

**SC Tables: SC9xx**

900	D	Electrical total counter error
		The total counter contains something that is not a number.
		<ul style="list-style-type: none"> <li>▪ NVRAM incorrect type</li> <li>▪ NVRAM defective</li> <li>▪ NVRAM data scrambled</li> <li>▪ Unexpected error from external source</li> <li>▪ Counter was not finished counting which SRM demand during the SRM is receiving the PRT.</li> </ul>

920	B	Printer error
-00	-	No response at PM start up
-01		Timeout error during the PM operation
-02		Working memory error
-03		Cannot start-up the filtering process
-04		Abnormal exit from the filtering process
-		<p>An internal application error was detected and operation cannot continue.</p> <ul style="list-style-type: none"> <li>▪ Software defective; turn the machine off/on, or change the controller firmware</li> <li>▪ Insufficient memory</li> </ul>

Trouble-shooting

Service Call Conditions

921	B	Printer font error
-00	-	Resident font is not found
-01	-	Option font is not found
-	-	A necessary font is not found in the SD card.
		<ul style="list-style-type: none"> <li>▪ A necessary font is not found in the SD card.</li> <li>▪ The SD card data is corrupted.</li> </ul>

925	B	Net File function error
-00	-	HDD is defective
-01	-	NetFile management file is broken
-	-	The NetFile file management on the HDD cannot be used, or a NetFile management file is corrupted and operation cannot continue. The HDDs are defective and they cannot be debugged or partitioned, so the Scan Router functions (delivery of received faxes, document capture, etc.), Web services, and other network functions cannot be used. HDD status codes are displayed below the SC code.
		<ul style="list-style-type: none"> <li>▪ Refer to the four procedures below (Recovery from SC 925).</li> </ul>

Here is a list of HDD status codes:

Display	Meaning
(-1)	HDD not connected
(-2)	HDD not ready
(-3)	No label
(-4)	Partition type incorrect
(-5)	Error returned during label read or check
(-6)	Error returned during label write or check
(-7)	"filesystem" repair failed
(-8)	"filesystem" mount failed
(-9)	Drive does not answer command
(-10)	Internal kernel error
(-11)	Size of drive is too small
(-12)	Specified partition does not exist
(-13)	Device file does not exist

## Recovery from SC 925

### Procedure 1

If the machine shows SC codes for HDD errors (SC860 to SC865) with SC 925, do the recovery procedures for SC860 to SC865.

### Procedure 2

If "Procedure 1" is not the solution for the problem, do SP5832-001 (HDD – HDD Formatting (All)), then turn the machine power off and on.

SP5832-001 erases all document and address book data on the hard disks. Ask the customer before you do this SP code.

### Procedure 3

If "Procedure 2" is not the solution for the problem, replace the HDD.



## Service Call Conditions

990	D	Software error 1
		The software performs an unexpected function and the program cannot continue.
		<ul style="list-style-type: none"> <li>▪ Software defective, re-boot</li> </ul>
991	C	Software error 2
		The software performs an unexpected function. However, unlike SC990, recovery processing allows the program to continue.
		<ul style="list-style-type: none"> <li>▪ Software defective, re-boot</li> </ul>

In order to get more details about SC990 and SC991:

Execute SP7403 or print an SMC Report (SP5990) to read the history of the 10 most recent logged errors.

992	D	Undefined error
		Defective software program
		<ul style="list-style-type: none"> <li>▪ An error undetectable by any other SC code occurred</li> </ul>

994	C	Application Item Error
		The number of executed application items on the operation panel reach the maximum limit for the operation panel structure.
		<ul style="list-style-type: none"> <li>▪ Too much executed application items</li> </ul>

997	B	Software Error 3: Cannot select application function
		An application does not start after the user pushed the correct key on the operation panel.
		<ul style="list-style-type: none"> <li>▪ Software bug</li> <li>▪ A RAM or DIMM option necessary for the application is not installed or not installed correctly.</li> </ul>

998	D	Software Error 4: Application cannot start
		Register processing does not operate for an application within 60 s after the machine power is turned on. No applications start correctly, and all end abnormally.
		<ul style="list-style-type: none"><li>▪ Software bug</li><li>▪ A RAM or DIMM option necessary for the application is not installed or not installed correctly.</li></ul>

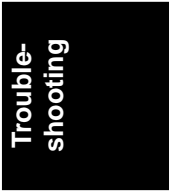

## 6.2 ELECTRICAL COMPONENT DEFECTS

### 6.2.1 SENSORS

Component (Symbol)	CN	Condition	Symptom
By-pass Paper Length Sensor	236-2 (IOB)	Open	Paper size error
		Shorted	
Duplex Entrance	217-A8 (IOB)	Open	Jam Z
		Shorted	Jam Z
Duplex Cover	217-A11 (IOB)	Open	"Open Cover" is displayed.
		Shorted	"Open cover" cannot be detected.
Duplex Exit	217-A14 (IOB)	Open	Jam Z
		Shorted	am Z (Jam 1)
By-pass Paper End	217-B3 (IOB)	Open	The Paper End indicator lights even if paper is placed on the by-pass tray.
		Shorted	The Paper End indicator does not light even if there is no paper on the by-pass tray.
By-pass Paper Size	217-B9, B10,B12,B13 (IOB)	Open	Paper size error
		Shorted	
Toner Overflow	217-B15 (IOB)	Open	CPU cannot detect the toner overflow even the waste toner in the transfer belt unit is full.
		Shorted	CPU detects the toner overflow even the waste toner in the transfer belt unit is not full.

Component (Symbol)	CN	Condition	Symptom
Paper Feed 1	216-A4 (IOB)	Open/Shorted	No symptom, but this may cause Jam A, and some pieces of paper are remaining at the paper feed unit when tray 1 is opened.
Relay 1	216-A7 (IOB)	Open	Jam A
		Shorted	Jam A, B
Paper End 1	216-A10 (IOB)	Open	The Paper End indicator lights even if paper is placed in the paper tray 1.
		Shorted	The Paper End indicator does not light even if there is no paper in the paper tray 1.
Tray Lift 1	216-A13 (IOB)	Open/Shorted	SC501 is displayed.
Paper Feed 2	216-B4 (IOB)	Open/Shorted	No symptom, but this may cause Jam A and some pieces of paper are remaining at the paper feed unit when tray 2 is opened.
Relay 2	216-B7 (IOB)	Open	Jam A
		Shorted	Jam A, B
Paper End 2	216-B10 (IOB)	Open	The Paper End indicator lights even if paper is placed in the paper tray 2.
		Shorted	The Paper End indicator does not light even if there is no paper in the paper tray 2.
Tray Lift 2	216-B13 (IOB)	Open/Shorted	SC502 is displayed.

## Electrical Component Defects

Component (Symbol)	CN	Condition	Symptom
Registration	209-2 (IOB)	Open	Jam A (Jam 8, 17)
		Shorted	Jam A, B (Jam 1)
Paper Size 1	209-4, 5, 5, 8 (IOB)	Open/ Shorted	Paper size error in tray 1
Paper Size 2	209-9, 10, 11, 13 (IOB)	Open/ Shorted	Paper size error in tray 2
Lower Paper Height 1	210-4 (IOB)	Open/ Shorted	Remaining paper volume in tray 2 on the LCD is wrong.
Lower Paper Height 2	210-7 (IOB)	Open/ Shorted	
Upper Paper Height 1	210-12 (IOB)	Open/ Shorted	Remaining paper volume in tray 1 on the LCD is wrong.
Upper Paper Height 2	210-15 (IOB)	Open/ Shorted	
Junction Jam	221-A10 (IOB)	Open/ Shorted	Jam C
Paper Exit	221-B2 (IOB)	Open	Jam C
		Shorted	Jam C
Fusing Exit	221-B5 (IOB)	Open	Jam C
		Shorted	Jam C
Paper Overflow	221-B8 (IOB)	Open	Paper overflow message is not displayed when a paper overflow condition exists.
		Shorted	Paper overflow message is displayed when a paper overflow condition does not exist.

Component (Symbol)	CN	Condition	Symptom
TD (Toner Density)	213-14 (IOB)	Open	The add toner indicator blinks even if there is toner in the development unit.
		Shorted	SC390 is displayed.
Web End	208-16 (IOB)	Open	CPU detects the web end even the web is not used up.
		Shorted	CPU cannot detect the web end even the web is used up.
ID (Image Density)	208-11 (IOB)	Open	SC350 is displayed after copying.
		Shorted	SC351 is displayed after copying.
Fusing Entrance	208-8 (IOB)	Open	CPU cannot detect paper even a sheet of paper remains at the fusing unit.
		Shorted	CPU detects paper even a sheet of paper does not remain at the fusing unit.

## 6.2.2 SWITCHES

Component (Symbol)	CN	Condition	Symptom
Right Door	221-B10 (IOB)	Open	"Open Cover" is displayed even if the right door is closed.
		Shorted	The LCD goes blank when the right door is opened.
Main Power	903-1,2 (PSU)	Open	The machine does not turn on.
		Shorted	The machine does not turn off.
Interlock	913-1,2 (PSU)	Open	"Doors/Covers Open" is displayed even if the front or right door is closed.
		Shorted	The LCD goes blank when the front or right door is opened.

## 6.3 BLOWN FUSE CONDITIONS

### CAUTION

- Use a correct rating fuse for the fuse replacement. Never use a wrong rating fuse. If do so, the machine may be damaged.

Fuse	Rating		Symptom at power on
	115V	210 to 230V	
Power Supply Board			
FU21	6.3A / 250V	6.3A / 250V	SC 533 (Power to IOB)
FU22	6.3A / 250V	6.3A / 250V	No response
FU23	10A / 250V	10A / 250V	"Open Cover" is displayed. (Power to Interlock Switch)
FU24	10A / 250V	10A / 250V	"Open Cover" is displayed. (Power to Interlock Switch)
FU25	6.3A / 250V	6.3A / 250V	Alert LED turns on and operation panel does not turn on. (Power to MB)
FU26	6.3A / 250V	6.3A / 250V	Stack paper in the optional paper feed unit or LCT is not detected. SC 503 is issued after opening and closing the tray 3 or 4. (Power to optional PFU or LCT)
FU27	6.3A / 250V	6.3 A / 250V	The machine does not detect a finisher. (Power to optional Finisher)
FU101	15A / 250V	8A / 250V	No response
FU102	12A / 250V	4A / 250V	No response



## 6.4 FUSES

Fuse Address	Part No.	Q'ty
FU11	11071229	1
FU21, 22, 25, 26, 27	11071295	5
FU23, 24	11071216	2
FU101	Differs depending on the voltage system. <ul style="list-style-type: none"><li>▪ 100V : 11071252</li><li>▪ 200V: 11071218</li></ul>	1
FU102	Differs depending on the voltage system. <ul style="list-style-type: none"><li>▪ 100V: 11071320</li><li>▪ 200V: 11071217</li></ul>	1
FU103, 12, 14	11071225	3

# **ENERGY SAVING**



## 7. ENERGY SAVING

### 7.1 ENERGY SAVE

#### 7.1.1 ENERGY SAVER MODES

Customers should use energy saver modes properly, to save energy and protect the environment.

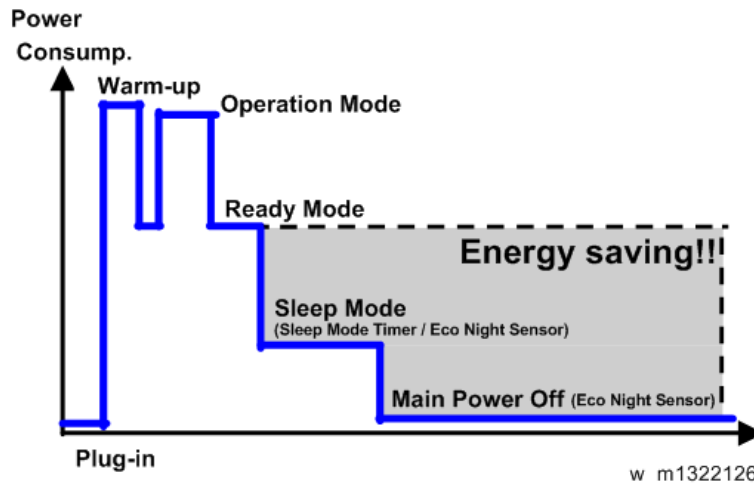

The area shaded grey in this diagram represents the amount of energy that is saved when the timers are at the default settings. If the timers are changed, then the energy saved will be different. For example, if the sleep mode timer is set to 240 min., the grey area will disappear, and no energy is saved before 240 min. expires.

#### **Timer Settings**

The user can set these timers with User Tools (System settings > Timer settings)

- **Sleep mode timer (1 – 240 min):**  
The machine waits this amount of time to enter the sleep mode.  
Default setting: 1 min
- **Eco Night Sensor (1/5/30/60/120 min):**  
The machine waits this amount of time to enter the sleep mode or to turn off the power automatically after the night sensor ambient light level is low.  
Default setting: Power Off / 120 min / 1

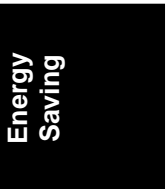

### ***Return to Stand-by Mode***

The recovery time from the sleep mode is 15 sec.

### ***Recommendation***

We recommend that the default settings should be kept.

- If the customer requests that these settings should be changed, please explain that their energy costs could increase, and that they should consider the effects on the environment of extra energy use.
- If it is necessary to change the settings, please try to make sure that the timer settings are not too long. Try with a shorter setting first, such as 30 min., then go to a longer one (such as 60 min.) if the customer is not satisfied.
- If the timers are all set to the maximum value, the machine will not begin saving energy until 240 minutes has expired after the last job. This means that after the customer has finished using the machine for the day, energy will be consumed that could otherwise be saved.
- If you change the settings, the energy consumed can be measured using SP8941, as explained below.

## **7.1.2 ENERGY SAVE EFFECTIVENESS**

SP 8941 (Machine Status) keeps a record of the amount of time that the machine spends in each mode.

- 8941-001: Operating mode
- 8941-002: Standby mode
- 8941-004: Low power mode

With this data, and the power consumption values from the specifications, we can estimate the amount of energy that is used by the machine.

This should only be used as a reference value, because the power consumption specifications are measured in a controlled environment with a constant power supply.

To get an exact measurement at the customers site, a watt meter must be used to measure the actual energy consumed.

To use SP8941 to calculate the energy consumed:

- At the start of the measurement period, read the values of SP8941 001 to 004.
- At the end of the measurement period, read the values of SP8941 001 to 004 again.
- Find the amount of time spent in each mode (subtract the earlier measurement from the later measurement).
- Multiply this by the power consumption spec for each mode.
- Convert the result to kWh (kilowatt hours)

## 7.2 PAPER SAVE

### 7.2.1 EFFECTIVENESS OF DUPLEX/COMBINE FUNCTION

Duplexing and the combine functions reduce the amount of paper used. This means that less energy overall is used for paper production, which improves the environment.

#### 1. Duplex:

Reduce paper volume in half!



#### 2. Combine mode:

Reduce paper volume in half!



### 3. Duplex + Combine:

Using both features together can further reduce paper volume by 3/4!



d062d101

To check the paper consumption, look at the total counter and the duplex counter.

The total counter counts all pages printed.

- For one duplex page, the total counter goes up by 2.
- For a duplex job of a three-page original, the total counter goes up by 3.

The duplex counter counts pages that have images on both sides.

- For one duplex page, the duplex counter goes up by 1.
- For a duplex job of a three-page original, the duplex counter will only increase by 1, even though two sheets are used.

### ***How to calculate the paper reduction ratio***

How to calculate the paper reduction ratio, when compared with Single-sided copying, with no 2-in-1 combine mode

Paper reduction ratio (%) = Number of sheets reduced: A/Number of printed original images: B x 100

- Number of sheets reduced: A  
= Output pages in duplex mode/2 + Number of pages in Single-sided with combine mode + Number of pages in Duplex with combine mode x 3/2  
 $A = ((2) + (3) + (4))/2 + (5) + (6) \times 3/2$
- Number of printed original images: B  
= Total counter6 + Number of pages in Single-sided with combine mode + Number of pages in Duplex with combine mode  
 $B = (1) + (5) + (6)$
- (1) Total counter: SP 8581 001 (pages)
- (2) Single-sided with duplex mode: SP 8421 001 (pages)
- (3) Double-sided with duplex mode: SP 8421 002 (pages)
- (4) Book with duplex mode: SP 8421 003 (pages)
- (5) Single-sided with combine mode: SP 8421 004 (pages)
- (6) Duplex with combine mode: SP 8421 005 (pages)
-



**M132**  
**SERVICE MANUAL APPENDICES**



# M132 APPENDICES

## TABLE OF CONTENTS

<b>1. APPENDIX: GENERAL SPECIFICATIONS .....</b>	<b>1-1</b>
1.1 GENERAL SPECIFICATIONS .....	1-1
1.1.1 MAIN FRAME .....	1-1
1.1.2 POWER CONSUMPTION .....	1-3
1.1.3 PRINTER CONTROLLER.....	1-4
1.2 SUPPORTED PAPER SIZES .....	1-6
1.2.1 PAPER FEED .....	1-6
North America .....	1-6
Europe/ Asia.....	1-9
1.2.2 PAPER EXIT.....	1-12
3000 Sheet Finisher (D636) .....	1-12
1000-Sheet Finisher (D588).....	1-15
1.3 SOFTWARE ACCESSORIES.....	1-17
1.3.1 PRINTER DRIVERS .....	1-17
1.3.2 UTILITY SOFTWARE .....	1-18
1.4 OPTIONAL EQUIPMENT.....	1-19
1.4.1 TWO-TRAY PAPER FEED UNIT (D580).....	1-19
1.4.2 LCT 2000-SHEET (D581).....	1-19
1.4.3 LCT 1200-SHEET (D631).....	1-20
1.4.4 BRIDGE UNIT (D634).....	1-20
1.4.5 1000-SHEET FINISHER (D588).....	1-21
Upper Tray .....	1-21
Lower Tray .....	1-21
1.4.6 3000-SHEET FINISHER (D636).....	1-22
1.4.7 PUNCH UNIT (D570) FOR 3000-SHEET FINISHER.....	1-25
1.4.8 OUTPUT JOGGER UNIT (B703).....	1-26
<b>2. APPENDIX: PM TABLES.....</b>	<b>2-1</b>
2.1 MAINTENANCE TABLES .....	2-1
2.1.1 MAINFRAME .....	2-1
2.1.2 OPTIONS.....	2-5

Paper Feed Unit (D580) .....	2-6
1200-Sheet LCT (D631) .....	2-6
2000-Sheet LCT (D581) .....	2-7
1000-Sheet Finisher (D588) .....	2-7
3000-Sheet Finisher (D636) .....	2-8
3000-Sheet Finisher Punch Unit (D570).....	2-8
Bridge Unit (D634) .....	2-8

### **3. APPENDIX: SERVICE PROGRAM MODE TABLES ..... 3-1**

3.1 SERVICE SP TABLES.....	3-1
3.2 ENTERING SP MODES .....	3-1
If The Power is Already On: .....	3-1
If The Power is Already Off: .....	3-1
3.2.2 SP1-XXX.....	3-1
3.3 ENGINE SP TABLES-1 .....	3-10
3.3.1 SP1-XXX: FEED .....	3-10
3.4 ENGINE SP TABLES-2 .....	3-27
3.4.1 SP2-XXX: DRUM.....	3-27
3.5 ENGINE SP TABLES-3 .....	3-51
3.5.1 SP3-XXX: PROCESS .....	3-51
3.6 ENGINE SP TABLES-4 .....	3-54
3.6.1 SP4-XXX: SCANNER .....	3-54
3.7 ENGINE SP TABLES-5 .....	3-55
3.7.1 SP5-XXX: MODE .....	3-55
3.8 ENGINE SP TABLES-6 .....	3-114
3.8.1 SP6-XXX: PERIPHERALS.....	3-114
3.9 ENGINE SP TABLES-7 .....	3-121
3.9.1 SP7-XXX: DATA LOG.....	3-121
3.10 ENGINE SP TABLES-8.....	3-138
3.10.1 SP8-XXX: DATA LOG2.....	3-138
3.11 INPUT CHECK.....	3-165
3.11.1 COPIER .....	3-165
Table 1: Paper Height Sensor .....	3-168
Table 2: Paper Size Switch .....	3-168
Table 3: Paper Size (By-pass Table) .....	3-169
APS Original Size Detection.....	3-170

- 3.11.2 OPTIONS..... 3-171
  - 3000/2000-Sheet (Booklet) Finisher (D636/D637) ..... 3-171
  - 1000-Sheet Finisher (D588) ..... 3-174
- 3.12 OUTPUT CHECK..... 3-176
  - 3.12.1 COPIER ..... 3-176
  - 3.12.2 1000-SHEET FINISHER (D588) ..... 3-182
  - 3.12.3 3000 /2000-SHEET (BOOKLET) FINISHER (D636/D637)..... 3-183
- 3.13 TEST PATTERN PRINTING ..... 3-185
- ⇒ 3.14 SP5749 IMPORT/EXPORT ..... 3-187



# APPENDIX: SPECIFICATIONS

REVISION HISTORY		
Page	Date	Added/Updated/New
		None





# 1. APPENDIX: GENERAL SPECIFICATIONS

## 1.1 GENERAL SPECIFICATIONS

### 1.1.1 MAIN FRAME

Configuration	Desktop	
Print Process	Dry electrostatic transfer system	
Resolution	200 / 300 / 600 dpi	
Gradation	256 tones	
First Print (Normal mode)	3.5 seconds or less (A4 / LT LEF)	
Warm-up Time	25 seconds or less from main power on. (23°C) 15 seconds or less from sleep mode off. (23°C)	
Print Paper Size	Standard Tray:	A3 / DLT (11" x 17") - A5 LEF Custom: Width: 182 - 297 mm (7.2" - 11.7") Length: 148 mm - 432 mm (5.8" - 17")
	By-pass Tray:	12" x 18" / 305 x 457.2 mm, A3/ DLT (11" x 17") - A6 SEF, Postcard Custom: Width: 90 - 305 mm (3.6" - 12") Length: 148 - 1260 mm (5.8" - 49.6")
	Duplex:	A3 / DLT(11" x 17") – A5 LEF / LT
Print Paper Weight	Paper trays:	60 - 216 g/m <sup>2</sup> (16 lb. Bond - 80 lb. Cover)
	By-pass:	52 - 216 g/m <sup>2</sup> (14 lb. Bond - 80 lb. Cover)
	Duplex:	60 - 169 g/m <sup>2</sup> (16 lb. Bond - 90 lb. Index)

General Specifications

Printing speed:	Maximum 50 ppm (A4 / LT LEF)	
First Print (Normal mode)	3.5 seconds or less (A4 / LT LEF)	
Warm-up Time	25 seconds or less from main power on. (23°C) 15 seconds or less from sleep mode off. (23°C)	
Paper Capacity:	Standard: 1,200 sheets (550 sheets/tray x 2 with 100 sheets in the by-pass tray) Option: 4,400 sheets (550 sheets/tray x 2 with 100 sheets in the by-pass tray, 1200-sheet LCT and 2000-sheet LCT)	
Output Paper Capacity	Standard exit tray: <ul style="list-style-type: none"> <li>▪ 500 sheets (A4 / LT or less)</li> <li>▪ 250 sheets (B4 / LG or more)</li> </ul> Bridge Unit Tray <ul style="list-style-type: none"> <li>▪ 250 sheets (A4 / LT or less)</li> <li>▪ 125 sheets (B4 / LG or more)</li> </ul> 1000-sheet finisher <ul style="list-style-type: none"> <li>▪ 250 + 1000 sheets (80 g/m<sup>2</sup>)</li> </ul> 3000-sheet finisher: <ul style="list-style-type: none"> <li>▪ 250 + 3000 sheets (80 g/m<sup>2</sup>)</li> </ul>	
Power Source	North America:	120 – 127V / 60Hz, 12 A
	Europe/Asia:	220 – 240 V/50, 60 Hz, 7 A
	Taiwan	110V/60Hz, 14 A
Dimensions (W x D x H)	670 x 684 x 640 mm	
Weight	Less than 73 kg (160.9 lb.)	

Toner Replenishment	Cartridge exchange (630 g)
Total Counter	Electric counter
Noise Emission: Printing	48dB or less
Noise Emission: Stand-by	72dB or less

### 1.1.2 POWER CONSUMPTION

Basic		Power Consumption
Operating	NA	874W
	EU, Asia	874W
Sleep Mode	NA	3.5W or less
	EU, Asia	3.5W or less
Maximum	NA	1550W or less
	EU, Asia	1470W or less

**Note**

- The above measurements were made in accordance with ISO 7779.
- In the above "Panel Off" condition, the polygonal mirror motor is not rotating.

### 1.1.3 PRINTER CONTROLLER

<p>Printer Languages:</p>	<p>Standard</p> <ul style="list-style-type: none"> <li>▪ RPCS (Refined Printing Command Stream)</li> <li>▪ PCL 6(XL)/5e</li> <li>▪ PDF Direct</li> <li>▪ Adobe PostScript 3</li> <li>▪ MediaPrint: JPEG/TIFF</li> </ul> <p>Option</p> <ul style="list-style-type: none"> <li>▪ IPDS</li> </ul>
<p>Resolution and Gradation:</p>	<p>PCL 5e: 300 x 300 dpi 600 x 600 dpi : Fast (1-bit)</p> <p>PCL 6: 600 x 600 dpi : Fast (1-bit)</p> <p>PS3 / PDF Direct: 300 x 300 dpi / 600 x 600 dpi</p> <p>XPS: 600 x 600 dpi : Fast (1-bit)</p> <p>IPDS: 300 x 300 dpi/ 600 x 600 dpi</p>
<p>Resident Fonts:</p>	<p>PCL 6/5e (Standard):</p> <ul style="list-style-type: none"> <li>▪ 45 Compatible fonts</li> <li>▪ 13 International fonts, 6 Bitmap fonts</li> </ul> <p>Adobe PostScript 3 (Optional) / PDF Direct</p> <ul style="list-style-type: none"> <li>▪ 136 Compatible fonts</li> </ul> <p>IPDS (Optional)</p> <ul style="list-style-type: none"> <li>▪ 108 Compatible fonts</li> </ul>

Host Interfaces:	<p>Standard:</p> <ul style="list-style-type: none"> <li>▪ USB2.0 Type A (2 ports) and Type B</li> <li>▪ Ethernet (100 Base-TX/10 Base-T)</li> <li>▪ 3 SD slots (Operation panel, Option use, and service use)</li> </ul> <p>Optional:</p> <ul style="list-style-type: none"> <li>▪ Gigabit Ethernet (1000 Base-T)</li> <li>▪ IEEE1284 parallel x 1</li> <li>▪ IEEE802.11a/b/g (Wireless LAN)</li> <li>▪ NIC2Port (Print server)</li> </ul>
Network Protocols:	TCP/IP (IPv4, IPv6), IPX/SPX (Optional)
Memory	<p>Standard: 512 MB</p> <p>Maximum: 1024 MB</p> <p>(Resident 512 MB + Additional 512 MB)</p>
HDD	120 GB

## 1.2 SUPPORTED PAPER SIZES

### 1.2.1 PAPER FEED

#### *North America*

BT: By-pass Tray, Std Tray: Standard Tray, Op Tray: Optional Tray, LCT 1000: Large Capacity Tray: 1000-sheet, LCT 1200: Large Capacity Tray: 1200-sheet, DU: Duplex Unit

Paper	Size (W x L)	BT	Std Tray	Op Tray	LCT 1000	LCT 1200	DU
A3 SEF	297 x 420mm	B	B	B	-	-	S
A4 SEF	210 x 297mm	B	A	A	-	-	S
A4 LEF	297 x 210mm	B	B	B	B	B	S
A5 SEF	148 x 210mm	B	-	-	-	-	S
A5 LEF	210 x 148mm	B	A	A	-	-	S
A6 SEF	105 x 148mm	B	-	-	-	-	S
B4 SEF	257 x 364mm	B	B	B	-	-	S
B5 SEF	182 x 257mm	B	A	A	-	-	S
B5 LEF	257 x 182mm	B	B	B	-	B	S
B6 SEF	128 x 182mm	B	-	-	-	-	S
DLT SEF	11" x 17"	A	A	A	-	-	S
Legal SEF	8.5" x 14"	B	A	A	-	-	S
Foolscap SEF	8.5" x 13"	B	B	B	-	-	S
Letter SEF	8.5" x 11"	A	A	A	-	-	S
Letter LEF	11" x 8.5"	A	A	A	<b>B</b>	<b>B</b>	S
Government Legal SEF	8.25" x 14"	B	B	B	-	-	S
Folio SEF	8.25" x 13"	B	B	B	-	-	S

Paper	Size (W x L)	BT	Std Tray	Op Tray	LCT 1000	LCT 1200	DU
F/GL SEF	8" x 13"	B	B	B	-	-	S
G LT SEF	8" x 10.5"	B	B	B	-	-	S
G LT LEF	10.5" x 8"	B	B	B	-	-	S
Eng Quatro SEF	8" x 10"	B	B	B	-	-	S
Eng Quatro LEF	10" x 8"	B	-	-	-	-	S
Executive SEF	7.25" x 10.5"	B	B	B	-	-	S
Executive LEF	10.5" x 7.25"	B	A	A	-	-	S
Half Letter SEF	5.5" x 8.5"	A	-	-	-	-	S
12" x 18" (A3W) SEF	12" x 18"	B	B	B	-	-	-
11" x 15" SEF	11" x 15"	B	B	B	-	-	S
11" x 14" SEF	11" x 14"	B	B	B	-	-	S
10" x 15" SEF	10" x 15"	B	B	B	-	-	S
10" x 14" SEF	10" x 14"	B	B	B	-	-	S
Com10 SEF	4.13"x 9.5"	B	-	-	-	-	-
Com10 LEF	9.5"x 4.13"	B	B	B	-	-	-
Monarch SEF	3.88"x 7.5"	B	-	-	-	-	-
Monarch LEF	7.5"x 3.88"	B	-	-	-	-	-
C5 SEF	162 x 229mm	B	-	-	-	-	-
C5 LEF	229 x 162mm	B	B	B	-	-	-
C6 SEF	114 x 162mm	B	-	-	-	-	-
C6 LEF	162 x 114mm	B	-	-	-	-	-

## Supported Paper Sizes

Paper	Size (W x L)	BT	Std Tray	Op Tray	LCT 1000	LCT 1200	DU
DL Env SEF	110 x 220mm	B	-	-	-	-	-
DL Env LEF	220 x 110mm	B	B	B	-	-	-
Custom	Width						
	Length						

Custom	BT	Std / Op Tray	LCT1000 / 1200	DU
Width	90 -305mm (3.55"- 12")	182 - 297mm (7.17"- 11.69")	-	90 / 297mm (3.55"- 11.69")
Length	148 – 600mm (5.83"- 23.62")	148 – 432mm (5.83"- 17")	-	148 - 432mm (5.83"- 17")

### Remarks:

A	Supported and the size is automatically detected.
B	Supported but the size is not automatically detected. (The size needs to be set by operation panel and also printer driver.)
S	Supported
-	Not supported



**Europe/ Asia**

BT: By-pass Tray, Std Tray: Standard Tray, Op Tray: Optional Tray, LCT 1000: Large Capacity

Tray: 1000-sheet, LCT 1200: Large Capacity Tray: 1200-sheet, DU: Duplex Unit

Paper	Size (W x L)	BT	Std Tray	Op Tray	LCT 1000	LCT 1200	DU
A3 SEF	297 x 420mm	A	A	A	-	-	Y
A4 SEF	210 x 297mm	A	A	A	-	-	Y
A4 LEF	297 x 210mm	A	A	A	<b>B</b>	<b>B</b>	Y
A5 SEF	148 x 210mm	A	-	-	-	-	Y
A5 LEF	210 x 148mm	A	A	A	-	-	Y
A6 SEF	105 x 148mm	A	-	-	-	-	Y
B4 SEF	257 x 364mm	B	A	A	-	-	Y
B5 SEF	182 x 257mm	B	A	A	-	-	Y
B5 LEF	257 x 182mm	B	A	A	-	B	Y
B6 SEF	128 x 182mm	B	-	-	-	-	Y
DLT SEF	11" x 17"	B	B	B	-	-	Y
Legal SEF	8.5" x 14"	B	B	B	-	-	Y
Foolscap SEF	8.5" x 13"	B	B	B	-	-	Y
Letter SEF	8.5" x 11"	B	A	A	-	-	Y
Letter LEF	11" x 8.5"	B	B	B	B	B	Y
Government Legal SEF	8.25" x 14"	B	B	B	-	-	Y
Folio SEF	8.25" x 13"	B	B	B	-	-	Y
F/GL SEF	8" x 13"	B	B	B	-	-	Y
G LT SEF	8" x 10.5"	B	B	B	-	-	Y

## Supported Paper Sizes

Paper	Size (W x L)	BT	Std Tray	Op Tray	LCT 1000	LCT 1200	DU
G LT LEF	10.5" x 8"	B	B	B	-	-	Y
Eng Quatro SEF	8" x 10"	B	B	B	-	-	Y
Eng Quatro LEF	10" x 8"	B	-	-	-	-	Y
Executive SEF	7.25" x 10.5"	B	B	B	-	-	Y
Executive LEF	10.5" x 7.25"	B	B	B	-	-	Y
Half Letter SEF	5.5" x 8.5"	B	-	-	-	-	Y
12" x 18" (A3W) SEF	12" x 18"	B	B	B	-	-	-
11" x 15" SEF	11" x 15"	B	B	B	-	-	Y
11" x 14" SEF	11" x 14"	B	B	B	-	-	Y
10" x 15" SEF	10" x 15"	B	B	B	-	-	Y
10" x 14" SEF	10" x 14"	B	B	B	-	-	Y
Com10 SEF	4.13"x 9.5"	B	-	-	-	-	-
Com10 LEF	9.5"x 4.13"	B	B	B	-	-	-
Monarch SEF	3.88"x 7.5"	B	-	-	-	-	-
Monarch LEF	7.5"x 3.88"	B	-	-	-	-	-
C5 SEF	162 x 229mm	B	-	-	-	-	-
C5 LEF	229 x 162mm	B	B	B	-	-	-
C6 SEF	114 x 162mm	B	-	-	-	-	-
C6 LEF	162 x 114mm	B	-	-	-	-	-
DL Env SEF	110 x 220mm	B	-	-	-	-	-
DL Env LEF	220 x 110mm	B	B	B	-	-	-

Paper	Size (W x L)	BT	Std Tray	Op Tray	LCT 1000	LCT 1200	DU
Custom	Width						
	Length						

Custom	BT	Std / Op Tray	LCT1000 / 1200	DU
Width	90 -305mm (3.55"- 12")	182 - 297mm (7.17"- 11.69")	-	90 / 297mm (3.55"- 11.69")
Length	148 – 600mm (5.83"- 23.62")	148 – 432mm (5.83"- 17")	-	148 - 432mm (5.83"- 17")

**Remarks:**

A	Supported and the size is automatically detected.
B	Supported but the size is not automatically detected. (The size needs to be set by operation panel and also printer driver.)
S	Supported
-	Not supported

## 1.2.2 PAPER EXIT

### 3000 Sheet Finisher (D636)

MF: Main Frame, Prf: Proof, Clr: Clear, Shf: Shift, Stp: Staple, SS: Saddle Stitch,

2P: 2 Holes Punch, N2P: North Europe 2 Holes, 3P: 3 Holes Punch,

Punch 4 P: 4 Holes Punch, N4P: North Europe 4 Holes Punch

Paper	Size (W x L)	MF	3000-sheet finisher								
			Prf	Clr	Shf	Stp	SS	2P/N2P	3P	4P	N4P
A3 W	12" x 18"	Y	Y	Y	Y	30	15	-	-	-	-
A3 SEF	297 x 420 mm	Y	Y	Y	Y	30	15	Y	Y	Y	Y
A4 SEF	210 x 297 mm	Y	Y	Y	Y	50	15	Y	-	-	Y
A4 LEF	297 x 210 mm	Y	Y	Y	Y	50	-	Y	Y	Y	Y
A5 SEF	148 x 210 mm	Y	Y	Y	Y	-	-	Y	-	-	Y
A5 LEF	210 x 148 mm	Y	Y	Y	Y	-	-	Y	-	-	Y
A6 SEF	105 x 148 mm	Y	Y	Y	-	-	-	-	-	-	-
B4 SEF	257 x 364 mm	Y	Y	Y	Y	30	15	Y	Y	Y*4	Y*4
B5 SEF	182 x 257 mm	Y	Y	Y	Y	50	15	Y	-	-	Y
B5 LEF	257 x 182 mm	Y	Y	Y	Y	50	Y	Y	Y	Y	Y
B6 SEF	128 x 182 mm	Y	Y	Y	-	-	-	-	-	-	-

Paper	Size (W x L)	MF	3000-sheet finisher								
			Prf	Clr	Shf	Stp	SS	2P/N2P	3P	4P	N4P
Ledger	11" x 17"	Y	Y	Y	Y	30	15	Y	Y	Y	Y
Letter SEF	8.5" x 11"	Y	Y	Y	Y	50	15	Y	-	-	Y
Letter LEF	11" x 8.5"	Y	Y	Y	Y	50	-	Y	Y	Y	Y
Legal SEF	8.5" x 14"	Y	Y	Y	Y	30	15	Y	-	-	Y
Government Legal SEF	8.25" x 14"	Y	Y	Y	Y	30	-	Y	-	-	Y
Half Letter SEF	5.5" x 8.5"	Y	Y	Y	Y	-	-	Y	-	-	Y
Executive SEF	7.25" x 10.5"	Y	Y	Y	Y	50	-	Y	-	-	Y
Executive LEF	10.5" x 7.25"	Y	Y	Y	Y	50	-	Y	Y	Y	Y
F SEF	8" x 13"	Y	Y	Y	Y	30	-	Y	-	-	Y
Foolscap SEF	8.5" x 13"	Y	Y	Y	Y	30	-	Y	-	-	Y
Folio SEF	8.25" x 13"	Y	Y	Y	Y	30	-	Y	-	-	Y
	11" x 15"	Y	Y	Y	Y	30	-	Y	Y	Y	Y
	10" x 14"	Y	Y	Y	Y	30	-	Y	Y	-	Y
	8" x 10"	Y	Y	Y	Y	50	-	Y	-	-	Y
8K	267 x 390 mm	Y	Y	Y	Y	30	-	Y	Y	Y	Y
16K SEF	195 x 267 mm	Y	Y	Y	Y	50	-	Y	-	-	Y

Supported Paper Sizes

Paper	Size (W x L)	MF	3000-sheet finisher								
			Prf	Clr	Shf	Stp	SS	2P/N2P	3P	4P	N4P
16K LEF	267 x 195 mm	Y	Y	Y	Y	50	-	Y	Y	Y	Y
Custom		Y	Y	Y	-	-	-	Y*3	Y*3	Y*3	Y*3
Com10 Env.	4.125" x 9.5"	Y	Y*1	Y*2	-	-	-	-	-	-	-
Monarch Env.	3.875" x 7.5"	Y	-	Y	-	-	-	-	-	-	-
C6 Env.	114 x 162 mm	Y	-	Y	-	-	-	-	-	-	-
C5 Env.	162 x 229 mm	Y	-	Y	-	-	-	-	-	-	-
DL Env.	110 x 220 mm	Y	-	Y	-	-	-	-	-	-	-

Remarks:

Y	Supported
15	Output up to 15 sheets
30	Output up to 30 sheets
50	Output up to 50 sheets
-	Not supported

\*1: Minimum 100 mm or more, Maximum 600 mm or less

\*2: Minimum 100 mm or more, Maximum 600 mm or less

▪ Longer paper (feed length) than DLT (432 mm) is not guaranteed in this mode.

\*3: Minimum 100 mm for 2P, 230 mm for 3P, 255 mm for 4P, 125 mm for N4P

\*4: Corner stapling is not available in this mode.

**1000-Sheet Finisher (D588)**

MF: Main Frame, Prf: Proof, Clr: Clear, Shf: Shift, Stp: Staple

Paper	Size (W x L)	MF	1000-sheet finisher				1 Bin
			Prf	Clr	Shf	Stp	
A3 W	12" x 18"	Y	Y	Y	Y	30	-
A3 SEF	297 x 420 mm	Y	Y	Y	Y	30	Y
A4 SEF	210 x 297 mm	Y	Y	Y	Y	50	Y
A4 LEF	297 x 210 mm	Y	Y	Y	Y	50	Y
A5 SEF	148 x 210 mm	Y	Y	Y	Y	-	Y
A5 LEF	210 x 148 mm	Y	Y	Y	Y	-	Y
A6 SEF	105 x 148 mm	Y	Y	-	-	-	-
B4 SEF	257 x 364 mm	Y	Y	Y	Y	30	Y
B5 SEF	182 x 257 mm	Y	Y	Y	Y	50	Y
B5 LEF	257 x 182 mm	Y	Y	Y	Y	50	Y
B6 SEF	128 x 182 mm	Y	Y	-	-	-	N
Ledger	11" x 17"	Y	Y	Y	Y	30	Y
Letter SEF	8.5" x 11"	Y	Y	Y	Y	50	Y
Letter LEF	11" x 8.5"	Y	Y	Y	Y	50	Y
Legal SEF	8.5" x 14"	Y	Y	Y	Y	30	Y
Government Legal SEF	8.25" x 14"	Y	Y	Y	Y	30	Y
Half Letter SEF	5.5" x 8.5"	Y	Y	Y	Y	-	Y
Executive SEF	7.25" x 10.5"	Y	Y	Y	Y	50	Y
Executive LEF	10.5" x 7.25"	Y	Y	Y	Y	50	Y

Supported Paper Sizes

Paper	Size (W x L)	MF	1000-sheet finisher				1 Bin
			Prf	Clr	Shf	Stp	
F SEF	8" x 13"	Y	Y	Y	Y	30	Y
Foolscap SEF	8.5" x 13"	Y	Y	Y	Y	30	Y
Folio SEF	8.25" x 13"	Y	Y	Y	Y	30	Y
	11" x 15"	Y	Y	Y	Y	30	Y
	10" x 14"	Y	Y	Y	Y	30	Y
	8" x 10"	Y	Y	Y	Y	30	Y
8K	267 x 390 mm	Y	Y	Y	Y	30	Y
16K SEF	195 x 267 mm	Y	Y	Y	Y	50	Y
16K LEF	267 x 195 mm	Y	Y	Y	Y	50	Y
Custom		Y	Y	-	-	-	-
Com10 Env.	4.125" x 9.5"	Y	-	-	-	-	-
Monarch Env.	3.875" x 7.5"	Y	-	-	-	-	-
C6 Env.	114 x 162 mm	Y	-	-	-	-	-
C5 Env.	162 x 229 mm	Y	-	-	-	-	-
DL Env.	110 x 220 mm	Y	-	-	-	-	-

Remarks:

Y	Supported
30	Output up to 30 sheets
50	Output up to 50 sheets
-	Not supported



## 1.3 SOFTWARE ACCESSORIES

The printer drivers and utility software are provided on one CD-ROM. An auto-run installer allows you to select which components to install.

### 1.3.1 PRINTER DRIVERS

Printer Language	Windows XP <sup>*1*6</sup>	Windows Vista <sup>*2*6</sup>	Windows 7 <sup>*3*6</sup>
PCL 5e/6	Yes	Yes	Yes
PS3	Yes	Yes	Yes

Printer Language	Windows Server 2003 <sup>*4*6</sup>	Windows Server 2008 or later <sup>*5*6</sup>	Macintosh <sup>*7</sup>
PCL 5e/6	Yes	Yes	No
PS3	Yes	Yes	Yes

\*1 Microsoft Windows XP Professional Edition / Home Edition

\*2 Microsoft Windows Vista Home Basic / Home Premium / Business / Enterprise / Ultimate

\*3 Microsoft Windows 7 Home Premium / Professional / Enterprise / Ultimate

\*4 Microsoft Windows Server 2003 Standard Edition / Enterprise Edition, Microsoft Windows Server 2003 R2 Standard Edition / Enterprise Edition

\*5 Microsoft Windows Server 2008 Standard / Enterprise, Microsoft Windows Server 2008 R2 Standard / Enterprise

\*6 Supports both versions (32/64 bit)

\*7 Mac OS X 10.4 or later (native mode). Any versions higher than Mac OS X 10.7 are not supported.

#### ↓ Note

- The PCL5c/6 and PS3 drivers are provided on the CD-ROM
- The PS3 drivers are all genuine Adobe PS drivers, except for Windows XP / 2003 / Vista / 7.
- A PPD file for each operating system is provided with the driver.

### 1.3.2 UTILITY SOFTWARE

Software	Description
Font Manager (XP / Vista)	A font management utility with screen fonts for the printer This is provided on the printer drivers CD-ROM

## 1.4 OPTIONAL EQUIPMENT

### 1.4.1 TWO-TRAY PAPER FEED UNIT (D580)

Paper Feed System:	FRR
Paper Height Detection:	5 steps (100%, 70%, 30%, 10% (Near end), and Empty)
Capacity:	550 sheets x 2 trays
Paper Weight:	60 to 216 g/m <sup>2</sup> (16 to 80 lb. Cover)
Paper Size:	A3 SEF to A5, DLT SEF to HLT
Power Source:	DC 24V, 5V (from the main frame)
Power Consumption:	Less than 40 W (Max.)/ Less than 25 W (Ave.)
Dimensions (W x D x H):	580 mm x 629 mm x 260 mm (22.8" x 24.8" x 10.2")
Weight:	26 kg (57.3 lb.)

### 1.4.2 LCT 2000-SHEET (D581)

Paper Size:	A4 LEF/LT LEF
Paper Weight:	52 to 256 g/m <sup>2</sup> (- to 68 lb.)
Tray Capacity:	2,000 sheets (80 g/m <sup>2</sup> , 20lb.)
Remaining Paper Detection:	5 steps (100%, 70%, 30%, 10%, Empty): Right Tray 4 steps (100%, 70%, 30%, Empty): Left Tray
Power Source:	DC 24 V, 5 V (from copier/printer)
Power Consumption:	55 W (Max.)/30 W (Ave.)
Weight:	26 kg (57.3 lb.)
Size (W x D x H):	580 mm x 620 mm x 260 mm (22.8" x 24.4" x 10.2")

**1.4.3 LCT 1200-SHEET (D631)**

Paper Size:	A4 LEF/LT LEF/B5 LEF
Paper Weight:	52 to 256 g/m <sup>2</sup> (- to 68 lb.)
Tray Capacity:	1,200 sheets (80 g/m <sup>2</sup> , 20lb.)
Remaining Paper Detection:	5 steps (100%, 70%, 30%, 10%, Empty)
Power Source:	DC 24 V, 5 V (from copier/printer)
Power Consumption:	55 W (Max.)/25 W (Ave.)
Weight:	14 kg (30.8 lb.)
Size (W x D x H):	348 mm x 540 mm x 290 mm (13.7" x 21.3" x 11.4")

**1.4.4 BRIDGE UNIT (D634)**

Paper Size:	Standard sizes A6 SEF to A3, HLT to DLT Non-standard sizes Width: 90 to 305 mm Length: 148 to 1260 mm
Paper Weight:	52 g/m <sup>2</sup> to 256 g/m <sup>2</sup> , 16 lb. to 68 lb.
Paper Capacity:	250 sheet (A4/ 8 1/2" x 11 1/2" or smaller: 80g/m <sup>2</sup> / 20 lbs) 125 sheet (B4 8 1/2" x 11 1/2" or larger: 80g/m <sup>2</sup> / 20 lbs)
Power Source:	DC 24 V, 5 V (form the copier/printer)
Dimensions (W x D x H):	415 mm x 412 mm x 111 mm (16.3" x 16.2" x 4.4")
Weight	5 kg (11 lb.)

### 1.4.5 1000-SHEET FINISHER (D588)

#### Upper Tray

Paper Size:	12" x 18"/305 x 457.2 mm, A3 to A6, 11" x 17" to 5.5" x 8.5"
Paper Weight:	52 to 256 g/m <sup>2</sup> (14 to 68 lb. Bond)
Paper Capacity:	250 sheets (A4, LT or smaller) 50 sheets (B4, LG or larger)

#### Lower Tray

Paper Size:	No staple mode: 12" x 18"/305 x 457.2 mm, A3 to B5, DLT to HLT Staple mode: 12" x 18"/305 x 457.2 mm, A3, B4, A4, B5, DLT to LT		
Paper Weight:	No staple mode: 52 to 160 g/m <sup>2</sup> (14 lb. Bond to 60 lb. Cover) Staple mode: 64 to 90 g/m <sup>2</sup> (17 to 24 lb. Bond)		
Stapler Capacity:	50 sheets (A4, B5, LT) 30 sheets (A3, B4, DLT, LG)		
Paper Capacity:	No staple mode: 1,000 sheets (A4/LT or smaller: 80 g/m <sup>2</sup> , 20 lb.) 500 sheets (B4 /LG or larger: 80 g/m <sup>2</sup> , 20 lb.) Staple mode: (80 g/m <sup>2</sup> , 20 lb., number of sets)		
	Paper Size	Sheets	Sets
	A4,/LT LEF, B5 LEF	2 to 9	100
	A4,/LT LEF,	10 to 50	100 to 20
	A4,/LT LEF, B5 LEF	10 to 50	50 to 10
	A3, B4, DLT, LG	2 to 9	50

## Optional Equipment

	A3, B4, DLT, LG	10 to 30	50 to 10
Staple positions:	Top, Bottom, 2 Staples		
Staple Replenishment:	Cartridge (5,000 staples/cartridge)		
Power Source:	DC 24 V, 5 V (from the copier/printer)		
Power Consumption:	50 W		
Weight:	25 kg (55.2 lbs)		
Dimensions (W x D x H):	520 x 520 x 790 mm (20.5" x 20.5" x 31.2")		

### 1.4.6 3000-SHEET FINISHER (D636)

Finisher		
Dimension (w x d x h)	657 mm x 613 mm x 960 mm (25.9" x 24.2" x 37.8")	
Weight	Less than 54 kg (119 lb.) (no punch unit) Less than 56 kg (123.5 lb.) (with punch unit)	
Power Consumption	Less than 96 W	
Noise	Less than 75 db	
Configuration	Console type attached base-unit	
Power Source	From base-unit	
Proof Tray	Stack Capacity	250 sheets: A4, 8.5" x 11" or smaller 50 sheets: B4, 8.5" x 14 or larger
	Paper Size	A6 SEF, B6 SEF, A5-A3 SEF, 5.5" x 8.5"-11" x 17" SEF, 12" x 18" SEF
	Paper Weight	52 g/m <sup>2</sup> - 160 g/m <sup>2</sup> (14 lb. Bond - 60 lb. Cover)

Shift Tray	Stack Capacity	3,000 sheets	A4 LEF, 8.5" x 11" LEF
		1,500 sheets	A3 SEF, A4 SEF, B4 SEF, B5, 11" x 17" SEF, 8.5" x 14" SEF, 8.5" x 11" SEF, 12" x 18" SEF
		500 sheets	A5 LEF
		100 sheets	A5 SEF, B6 SEF, A6 SEF, 5.5" x 8.5" SEF
	Paper Size	A5 - A3 SEF, A6 SEF, B6 SEF, 5.5" x 8.5"- 11" x 17" SEF, 12" x 18" SEF	
Paper Weight	52 g/m <sup>2</sup> - 256 g/m <sup>2</sup> (14 lb. Bond - 68 lb. Bond)		
Staples			
Paper Size		B5 - A3 8.5" x 11" - 11" x 17", 12" x 18"	
Paper Weight		64 g/m <sup>2</sup> - 90 g/m <sup>2</sup> (17 lb. Bond - 20 lb. Bond)	
Staple Position		Top, Bottom, 2 Staple, Top-slant	
Stapling Capacity	Same Paper Size	50 sheets	A4, 8.5" x 11" or smaller
		30 sheets	B4, 8.5" x 14" or larger
	Mixed Paper Size	30 sheets	A4 LEF + A3 SEF, B5 LEF + B4 SEF, 8.5" x 11" LEF + 11" x 17" SEF

Optional Equipment

Staple Replenishment	Cartridge exchange / 5000 pins per cartridge		
Stapled Stack Capacity (same size)	Paper Size	Pages/Set	Sets
	A4 LEF, 8.5" x 11" LEF	20 - 50 pages	150 - 60 sets
		2 - 19 pages	150 sets
	A4 SEF, B5, 8.5" x 11" SEF	15 - 50 pages	100 - 30 sets
		2 - 14 pages	100 sets
	Others	15 - 30 pages	100 - 33 sets
		2 - 14 pages	100 sets
	Stapled Stack Capacity (mixed sizes)	A4 LEF & A3 SEF, B5 LEF & B4 SEF, 8.5" x 11" LEF & 11" x 17" SEF,	2 - 30 pages



### 1.4.7 PUNCH UNIT (D570) FOR 3000-SHEET FINISHER

Available Punch Units		NA	2/3 holes switchable
		EU	2/4 holes switchable
		Scandinavia	4 holes
Punch Waste Replenishment		NA 2-holes	Up to 5,000 sheets
		NA 3-holes	Up to 5,000 sheets
		EU 2-holes	Up to 14,000 sheets
		EU 4-holes	Up to 7,000 sheets
		Scandinavia 4-holes	Up to 7,000 sheets
Paper Weight		52 g/m <sup>2</sup> - 163 g/m <sup>2</sup> , 14 lb Bond - 43 lb Bond	
Paper Sizes	NA 2-holes	SEF	A5 to A3, 5.5" x 8.5" to 11" x 17"
		LEF	A5 to A4, 5.5" x 8.5" , 8.5" x 11"
	NA 3-holes	SEF	A3, B4, 11" x 17"
		LEF	A4, B5, 8.5" x 11"
	EU 2-holes	SEF	A5 to A3, 5.5" x 8.5" to 11" x 17"
		LEF	A5 to A4, 5.5" x 8.5" , 8.5" x 11"
	EU 4-holes	SEF	A3, B4, 11"x17"
		LEF	A4, B5, 8.5" x 11"
	Scandinavia 4-holes	SEF	A5 to A3, 5.5" x 8.5" to 11" x 17"
		LEF	A5 to A4, 5.5" x 8.5" , 8.5" x 11"

### 1.4.8 OUTPUT JOGGER UNIT (B703)

This jogger unit is installed above the shift tray of the Finisher SR4080.

Paper Size:	
Paper Weight:	
Tray Capacity:	250 sheets (80 g/m <sup>2</sup> , 20 lb., A4 / LT)
Power Source:	
Power Consumption:	
Weight:	
Size (W x D x H):	

**APPENDIX:  
PM TABLES**



## 2. APPENDIX: PM TABLES

### 2.1 MAINTENANCE TABLES

Amounts mentioned as the PM interval indicate the number of prints.

#### 2.1.1 MAINFRAME

Chart: A4 (LT)/5%

Mode: 4 copies / original (prints/job)

Ratio 30%

Environment: Normal temperature and humidity

Yield may change depending on circumstances and print conditions.

Symbol keys: **C**: Clean, **R**: Replace, **L**: Lubricant, **I**: Inspect

Item	160K	320K	800K	EM	Remarks
<b>Drum (OPC) Area</b>					
Charge Roller	R				
Charge Roller Cleaning Roller	R				
Drum Cleaning Blade 1	R				
Side Seal	C				
Cleaning Entrance Seal	C				Blower brush
OPC Drum	R			I	Perform SP3-001-2 after the replacement.
Pick-off Pawls	R				
Spurs	C			I	Dry cloth
Quenching Lamp		C			
ID Sensor	C			I	Perform SP3-001-2 after blower brush cleaning.

Maintenance Tables

Item	160K	320K	800K	EM	Remarks
<b>Development Unit</b>					
Development Case	C			I	Dry cloth
Development Drive Gears				I	Dry cloth
Development Filter	R				
Developer	R			I	
Entrance Seal	C			I	
Side Seal	C				
Development Sleeve	C				Dry cloth
<b>Transfer Belt Unit</b>					
Transfer Belt	R				
Transfer Belt Cleaning Blade	R				Dry cloth To prevent damage to the cleaning blade, always replace these items together.
Transfer Belt Rollers	C				Dry cloth
Entrance Seal	C				Dry cloth
Used Toner Tank	C				Empty the tank
Seal (for paper dust)	C				
Transfer Entrance Guide	C			C	Dry cloth

Item	160K	320K	800K	EM	Remarks
<b>Fusing Unit</b>					
Hot Roller	R				
Pressure Roller	R				
Fusing Thermistors	R				
-	R				Blower brush or dry cloth
Cleaning Roller	C				
Cleaning Roller Bushings	L				Grease: Barrierta JFE 55/2
Fusing Entrance and Exit Guide Plates	C				Damp cloth Water / Alcohol
-	R				
Brake Pad		R			
-		R			

Maintenance Tables

Item	160K	320K	800K	EM	Remarks
<b>Paper Feed</b>					
Registration Roller	C			I	Damp cloth
Registration Sensor	C			I	Blower brush
Dust Blades	C			I	Detach and tap gently on flat surface to empty. Blower brush.
Feed Rollers	I			I	Damp cloth
Pick-up Belts	I			I	Damp cloth
Separation Rollers	I			I	Damp cloth
By-pass Feed Roller	I			I	Damp cloth
By-pass Pick-up Roller	I			I	Damp cloth
By-pass Separation Roller	I			I	Damp cloth
Paper Feed Guides	I			I	Blower brush or dry cloth
Relay Rollers	I			I	Damp cloth
Bottom Plate Pad	I			I	Damp cloth
Bottom Plate Pad (By-pass feed)	I			I	Damp cloth
By-pass Feed Roller Gear	L			I	Silicone Grease G-501
Relay Sensors	C			I	Blower brush
Paper Feed Sensors	I			I	Blower brush



Item	160K	320K	800K	EM	Remarks
<b>Duplex Unit</b>					
Inverter Rollers	I			I	Damp cloth
Transport Rollers	I			I	Damp cloth
Entrance Sensor	I			I	Blower brush
Exit Sensor	C			I	Blower brush
<b>Paper Exit</b>					
Paper Exit Sensor	I			I	Blower brush
Junction Gate Jam sensor	C			I	Blower brush
Fusing Exit Sensor	I			I	Blower brush
Paper Exit Rollers	I			I	Damp cloth
Junction Transport Roller	I			I	Damp cloth
Paper Exit Guide	I			I	Damp cloth

## 2.1.2 OPTIONS

Amounts mentioned as the PM interval indicate the number of prints/ originals.

Symbol key: **C**: Clean, **R**: Replace, **L**: Lubricate, **I**: Inspect

**Paper Feed Unit (D580)**

Item	EM	Remarks
Feed Roller	C	Dry cloth
Separation Roller	C	Dry cloth
Pick-up Roller	C	Dry cloth
Paper Feed Sensor	C	Dry cloth
Relay Sensor	C	Dry cloth
Relay Roller	C	Damp cloth
Bottom Plate Pad	C	Damp cloth

**1200-Sheet LCT (D631)**

Item	EM	Remarks
Feed Roller	C	Dry cloth
Separation Roller	C	Dry cloth
Pick-up Roller	C	Dry cloth
Paper Feed Sensor	C	Dry cloth
Relay Sensor	C	Dry cloth
Relay Roller	C	Damp cloth
Bottom Plate Pad	C	Damp cloth

**2000-Sheet LCT (D581)**

Item	EM	Remarks
Feed Roller	C	Dry cloth
Separation Roller	C	Dry cloth
Pick-up Roller	C	Dry cloth
Paper Feed Sensor	C	Dry cloth
Relay Sensor	C	Dry cloth
Relay Roller	C	Damp cloth
Bottom Plate Pad	C	Damp cloth

Appendix:  
PM Tables**1000-Sheet Finisher (D588)**

Item	150K	300K	450K	EM	Remarks
Rollers				C	Damp cloth (Water / Alcohol)
Discharge Brush	C			C	Dry cloth
Sensors				C	Blower brush
Jogger Fences	I			I	Replace if required

**3000-Sheet Finisher (D636)**

Item	EM	Remarks
Rollers	C	Damp cloth (Water / Alcohol)
Discharge Brush	C	Dry cloth
Sensors	C	Blower brush
Jogger Fences	I	Replace if required

**3000-Sheet Finisher Punch Unit (D570)**

Item	EM	Remarks
Punch Chads	C	Discard chads

**Bridge Unit (D634)**

Item	EM	Remarks
Rollers	C	Damp cloth (Water / Alcohol)
Copy Tray	C	Dry or damp cloth
Sensors	C	Blower brush

# **APPENDIX:**

## **SERVICE PROGRAM MODE TABLES**

<b>REVISION HISTORY</b>		
<b>Page</b>	<b>Date</b>	<b>Added/Updated/New</b>
1	01/15/2013	Entering SP Mode Added
60	8/15/2013	SP5305-101 Blue Angel Compliance
72	5/9/2013	SP5749 Import/Export
136	6/4/2013	SP7952-001, 002, 003
187 ~ 193	5/9/2013	SP5749 Import/Export



## 3. APPENDIX: SERVICE PROGRAM MODE TABLES



### 3.1 SERVICE SP TABLES

### ⇒ 3.2 ENTERING SP MODES

#### *If The Power is Already On:*

Press the "Home"  and "Simple screen"  keys at the same time for more than 3 seconds, and then press the "User tool"  key.

#### *If The Power is Already Off:*

Press the "Home"  and "Suspend"  keys at the same time while turning the main switch on.

#### 3.2.2 SP1-XXX

1001	Bit Switch			
001	Bit Switch 1		0	1
	bit 0	DFU	-	-
	bit 1	DFU	-	-
	bit 2	DFU	-	-
	bit 3	<b>No I/O Timeout</b>	0: Disable	1: Enable
		Enable: The MFP I/O Timeout setting will have no effect. I/O Timeouts will never occur.		
	bit 4	<b>SD Card Save Mode</b>	0: Disable	1: Enable
		Enable: Print jobs will be saved to an SD Card in the GW SD slot.		
	bit 5	DFU	-	-
	bit 6	DFU	-	-
bit 7	<b>[RPCS,PCL]: Printable area frame border</b>	0: Disable	1: Enable	
	Enable: The machine prints all RPCS and PCL jobs with a border on the edges of the printable area.			

1001	Bit Switch			
002	Bit Switch 2		0	1
	bit 0	DFU	-	-
	bit 1	DFU	-	-
	bit 2	<b>Applying a collation Type</b>	Shift Collate	Normal Collate
		<p>A collation type (shift or normal) will be applied to all jobs that do not already have a 'Collate Type' configured.</p> <p><b>Note</b></p> <ul style="list-style-type: none"> <li>If #5-0 is enabled, this Bit Switch has no effect.</li> </ul>		
	bit 3	<b>[PCL5e/c,PS]: PDL Auto Switching</b>	0: Enable	1: Disable
		<p>Disable: The MFPs ability to change the PDL processor mid-job. Some host systems submit jobs that contain both PS and PCL5e/c. If Auto PDL switching is disabled, these jobs will not be printed properly.</p>		
	bit 4	DFU	-	-
	bit 5	DFU	-	-
bit 6	DFU	-	-	
bit 7	DFU	-	-	

1001	Bit Switch			
003	Bit Switch 3		0	1
	bit 0	DFU	-	-
	bit 1	DFU	-	-
	bit 2	<b>[PCL5e/c]: Legacy HP compatibility</b>	0: Disable	1: Enable
		<p>Enable: Uses the same left margin as older HP models such as HP4000/HP8000. In other words, the left margin defined in the job (usually "&lt;ESC&gt;*r0A") will be changed to "&lt;ESC&gt;*r1A"</p>		



	bit 3	DFU	-	-
	bit 4	DFU	-	-
	bit 5	DFU	-	-
	bit 6	DFU	-	-
	bit 7	DFU	-	-

<b>1001</b>	<b>Bit Switch</b>			
004	Bit Switch 4		0	1
	bit 0	DFU	-	-
	bit 1	DFU	-	-
	bit 2	DFU	-	-
	bit 3	<b>IPDS print-side reversal</b>	0: Disable	1: Enable
	Enable: Increases printing speed but simplex pages may be printed on the back side of the sheet.			
	bit 4	DFU	-	-
	bit 5	DFU	-	-
	bit 6	DFU	-	-
	bit 7	<b>IPDS support tools</b>	0: Disable	1: Enable
	Enable: Enables the port for IPDS support tools.			

Appendix:  
Service  
Program  
Mode Tables

1001	Bit Switch			
005	Bit Switch 5	0	1	
	bit 0	<b>Show "Collate Type", "Staple Type" and "Punch Type" buttons on the operation panel.</b>	Disable	Enable
		If enabled, users will be able to configure a Collate Type, Staple Type, and Punch Type from the operation panel. The available types will depend on the device and configured options. After enabling the function, the settings will appear under: "User Tools > Printer Features > System"		
	bit 1	<b>Multiple copies if a paper size or type mismatch occurs</b>	0: Disable (Single copy)	1: Enable (Multiple copy)
		If a paper size or type mismatch occurs during the printing of multiple copies, only a single copy is output by default. Using this Bit Switch, the device can be configured to print all copies even if a paper mismatch occurs.		
	bit 2	<b>Prevent SDK applications from altering the contents of a job</b>	0: Disable	1: Enable
		If this BitSw is enabled, SDK applications will not be able to alter print data. This is achieved by preventing SDK applications from accessing a module called the "GPS Filter". Note: The main purpose of this BitSw is for troubleshooting the effects of SDK applications on data.		
	bit 3	<b>[PS] PS Criteria</b>	Pattern3	Pattern1
		Change the number of PS criterion used by the PS interpreter to determine whether a job is PS data or not. Pattern3: includes most PS commands. Pattern1: A small number of PS tags and headers		
	bit 4	<b>Increase max number of the stored jobs to 1000 jobs.</b>	Disable (100)	Enable (1000)

		Enable: Changes the maximum number of jobs that can be stored on the HDD via Job Type settings to 1000. The default is 100.		
	bit 5	DFU	-	-
	bit 6	<b>Method for determining the image rotation for the edge to bind on.</b>	0: Disable	1: Enable
		<p>If enabled, the image rotation will be performed as they were in the specifications of older models for the binding of pages of mixed orientation jobs.</p> <p>The old models are below:</p> <ul style="list-style-type: none"> <li>- PCL: Pre-04A models</li> <li>- PS/PDF/RPCS:Pre-05S models</li> </ul>		
	bit 7	<b>Letterhead mode printing</b>	0: Disable	1: Enable (Duplex)
		<p>Routes all pages through the duplex unit.</p> <p>If this is disabled, simplex pages or the last page of an odd-paged duplex job are not routed through the duplex unit. This could result in problems with letterhead/pre-printed pages.</p> <p>Only affects pages specified as Letterhead paper.</p>		

Appendix:  
Service  
Program  
Mode Tables

1001	Bit Switch			
006	Bit Switch 6 <b>DFU</b>	-	-	

1001	Bit Switch			
007	Bit Switch 7	0	1	
	bit 0	<b>Print path</b>	0: Disable	1: Enable
		<p>If enabled, simplex pages (in mixed simplex/duplex PS/PCL5 jobs only) and the last page of an odd paged duplex job (PS, PCL5, PCL6), are always routed through the duplex unit. Not having to switch paper paths increases the print speed slightly.</p>		
	bit 1 to 7	DFU	-	-

1001	Bit Switch			
008	Bit Switch 8 <b>DFU</b>		-	-
	bit 0 to 3	DFU	-	-
	bit 4	<b>PCL edge to edge printing setting</b>	0: Disable (Standard)	1: Enable (BMS)
		Switches the edge to edge printing setting for custom-made machines (BMS).		
	bit 5 to 7	DFU	-	-

1001	Bit Switch			
009	Bit Switch 9		0	1
	bit 0	<b>PDL Auto Detection timeout of jobs submitted via USB or Parallel Port (IEEE 1284).</b>	"Disabled (Immediately)"	"Enabled (10 seconds)"
		To be used if PDL auto-detection fails. A failure of PDL autodetection doesn't necessarily mean that the job can't be printed. This bit switch tells the device whether to time-out immediately (default) upon failure or to wait 10 seconds.		
	bit 1	DFU	-	-
	bit 2	<b>Job Cancel</b>	Disabled (Not cancelled)	Enabled (Cancelled)
		<p>If this bit switch, all jobs will be cancelled after a jam occurs.</p> <p>Note: If this bitsw is enabled, printing under the following conditions might result in problems:</p> <ul style="list-style-type: none"> <li>- Job submission via USB or Parallel Port</li> <li>- Spool printing (WIM &gt; Configuration &gt; Device Settings &gt; System)</li> </ul>		
	bit 3	<b>PCL/PS bypass tray paper rotation (SEF/LEF)</b>	0: Disable	1: Enable

		<p>This bitsw causes the device to revert to the behavior of previous generations. It only takes effect if "Bypass Tray Setting Priority" = "Driver/Command".</p> <p>Previous spec (bitsw=1): If a standard sized paper mismatch occurred in the bypass tray, the MFP always prompted for SEF paper.</p> <p>If this bitsw=0 (default) then in the event of a standard sized paper mismatch, the MFP will always prompt for paper of the rotation (SEF/LEF) determined by the MFP bypass tray paper setting or by the bypass tray sensor.</p>		
	bit 4	<b>Response to PJI USTATUS when multiple collated copies are printed</b>	0: Disable	1: Enable
		<p>When enabled, if multiple collated copies are printed, the device no longer responds to PJI USTATUS with the number of pages in the current copy. Instead the device will return the total number of pages for all copies.</p>		
	Bit 5 to 7	DFU	-	-

Appendix:  
Service  
Program  
Mode Tables

1001	Bit Switch			
010	Bit Switch 10		0	1
	bit 0 to 4	DFU	-	-
	bit 5	<b>List / Test Print Lock</b>	0: Disable	1: Enable
		<p>If enabled, you can lock or unlock the [List/Test Print] items under the Pinter Features menu when the Store and Skip Errored Job Function is on.</p>		
	Bit 6	<b>Optional charge machines</b>	-	-
		<p>If enabled, you can use the optional charge machines when the Store and Skip Errored Job Function is on.</p>	0: Disable	1: Enable
	Bit 7	DFU	-	-

Service SP Tables

1001	Bit Switch			
011	Bit Switch 11		0	1
	bit 0	<b>List / Test Print menu</b>	0: Disable	1: Enable
		When enabled, the [Multiple Lists] menu is displayed in [List / Test Print] under the Printer Features menu.		
	bit 1	<b>Interrupt printing</b>	0: Job	1: Page
		Selects the units for the interrupt printing function. When you select "0," you can interrupt printing of a job while being processed. When you select "1," you can interrupt printing of a page while being processed.		
	Bit 2 to 7	DFU	-	-

1001	Bit Switch			
012	Bit Switch 12		0	1
	bit 0 to 7	DFU	-	-

1003	<b>[Clear Setting]</b>			
1003 001	Initialize Printer System			
	Initializes settings in the "System" menu of the user mode.			
1003 003	Delete Program			

1004	<b>[Print Summary]</b>	
1004 001	Print Printer Summary	
	Prints the service summary sheet (a summary of all the controller settings).	

1005		
1005 002		

1007	<b>[Supply Info.]</b>	
1007 001	[0 to 1 / 1 ]	
	0: Displays the info. 1: Does not display the info.	

1110	<b>[Media Print Device Setting]</b>	
1110 002	0: Disable 1: Enable	Selects the setting for the media print device.

1111	<b>[All Job Delete Mode]</b>	
1111 001	0: Excluding New Job 1: Including New Job	Selects whether to include an image processing job in jobs subject to full cancellation from the SCS job list.

## 3.2 ENGINE SP TABLES-1

### 3.2.1 SP1-XXX: FEED

1001*	Leading Edge Registration	
	Adjusts the leading edge registration by changing the registration clutch operation timing.	
001	Tray: Plain	[-9 to 9/ <b>0</b> / 0.1 mm step]
002	Tray: Thick 1	
003	Tray: Thick 2	
004	By-pass: Plain	
005	By-pass: Thick 1	
006	By-pass: Thick 2	
007	Duplex: Plain	
008	Duplex: Thick 1	

1002*	Side-to-Side Registration	
	Adjusts the side to side registration by changing the laser main scan start position for each mode.	
001	By-pass	[-4 to 4/ <b>0</b> / 0.1 mm step]
002	Tray 1	
003	Tray 2	
004	Tray 3	
005	Tray 4	
006	LCT	
007	Duplex	



1003*	Registration Buckle Adjustment	
	Adjusts the paper feed motor timing. Paper feed motor timing determines the amount of paper buckle at Registration. (A "+" setting causes more buckling.)	
001	Tray 1: Plain	[-9 to 5 / -4 / 1 mm step]
002	Tray 1: Thick 1	
003	Tray 1: Thick 2	
004	Tray 2, 3, 4: Plain	
005	Tray 2, 3, 4: Thick1	
006	Tray 2, 3, 4: Thick2	
007	By-pass: Plain	[-9 to 5 / -2 / 1 mm step]
008	By-pass: Thick 1	
009	By-pass: Thick 2	
010	Duplex: Plain	[-9 to 5 / -4 / 1 mm step]
011	Duplex: Thick 1	[-9 to 5 / -3 / 1 mm step]
012	LCT: Plain	[-9 to 5 / -4 / 1 mm step]
013	LCT: Thick1	
014	LCT: Thick2	

Appendix:  
Service  
Program  
Mode Tables

1007*	By-pass Paper Size Detection	
	Controls paper size detection for the by-pass feed table.	
001	Detection Timing	[-15 to 15 / 0 / 5 mm step]
002	LG Detection	[0 to 1 / 0 / 1] 0: LT SEF, 1: LG

1103*	Fusing Idling	
	<p>Switches fusing idling on/off. When on, printing will not start until enough time has elapsed so the hot roller can reach optimum temperature. This ensures even heat on the hot roller.</p> <p>Switch on if fusing on the 1st and 2nd copies is incomplete (this may occur if the room is cold.). You must switch SP1103-1 ON before you set the fusing interval with SP1103-2.</p>	
001	Enable Fusing Idling	<b>0 = Off</b> , 1 = On
002	Interval	[0 to 60 / <b>30</b> / 1 sec.]
003	Idling Time at Every Job	<p>Sets the machine to fusing idling only for 30 sec. for every job (when the original is set on the ARDF, when the ARDF cover is opened, etc.) and the fusing unit has reached the reload temperature (optimum temperature for operation).</p> <p>[0 to 30 / <b>0</b> / 1 sec.]</p> <p>0: No idling done before a job.</p>

1104*	Fusing Temperature Control
	On-Off/Phase
	<p>Selects the fusing temperature control method. After changing this setting, be sure to turn the machine off and on again with the main power switch to enable the new setting.</p> <p>[0 to 1 / <b>0</b> / 1]</p> <p>0: Normal (ON/OFF control). Allows full application from ac power supply to bring the hot roller up to the target fusing temperature then shuts off. Determines the on-time from the present temperature (detected by the thermistor on the hot roller) and the temperature of 1 cycle before.</p> <p>1: Phase (hysteresis) control. Sets the upper and lower limits for the temperature; at the lower temperature the fusing lamp is on and at the higher temperature the fusing lamp is off.</p> <p>Change this setting to "0" only if the user has excessive electrical noise or interference on the power supply line. Such interference can cause voltage to drop when power is applied using the ON/OFF control method.</p> <p>Interference can be caused by the general poor quality of the power supply lines, or if the machine is sharing a power supply with other electrical devices such as fluorescent lights. Before changing this setting, make sure that the machine is connected to a power supply not shared by other electrical equipment.</p> <p><b>Note</b></p> <ul style="list-style-type: none"> <li>▪ Selecting Phase control ("1") could cause the fusing temperature control board to emit low pitched noise</li> </ul>

Appendix:  
Service  
Program  
Mode Tables

1105*	Fusing Temperature Adjustment	
	<p>Allows adjustment of the hot roller temperature at the center and ends of the roller for the quality or thickness of the paper. The hot roller in this machine has two fusing lamps: one heats the center of the roller, the other heats both ends. Each fusing lamp can be adjusted separately.</p> <p>The "re-load temperature" is the "print ready temperature". When the fusing temperature exceeds this setting, the machine can operate. Do not set up a re-load temperature (Re-load Temp. = Fusing. Temp – SP Value.) that is higher than the SP1-105-2 setting.</p>	
001	Roller Center	[100 to 170 / <b>150</b> / 1 deg]
	Adjusts the fusing temperature at the center of the hot roller.	
002	Roller Ends	[100 to 170 / <b>155</b> / 1 deg]
	Adjusts the fusing temperature at the ends of the hot roller.	
003	Re-load Temp. Minus: Roller Center	[0 to 60 / <b>0</b> / 1 deg]
	<p>Sets the reload temperature for the center of the hot roller. This setting depends on the target temperature.</p> <p>Reload temp. = Target Temp – This SP Setting</p> <p><b>Note</b></p> <ul style="list-style-type: none"> <li>Do not set a temperature that is higher than the setting for SP1105 1 (Roller Center: Trays)</li> </ul>	
004	Re-load Temp. Minus: Roller Ends	[0 to 60 / <b>0</b> / 1 deg]
	<p>Sets the reload temperature for the ends of the hot roller. This setting depends on the target temperature.</p> <p>Reload temp. = Target Temp – This SP Setting</p> <p><b>Note</b></p> <ul style="list-style-type: none"> <li>Do not set a temperature that is higher than the setting for SP1105 2 (Roller Ends: Trays)</li> </ul>	
005 to 022	The following SPs adjust the fusing temperature at the center or ends of the hot roller for each paper type.	

005	Roller Center: M-Thick	[100 to 170 / <b>155</b> / 1 deg]
006	Roller Ends: M-Thick	[100 to 170 / <b>160</b> / 1 deg]
007	Roller Center: Thick 1	[100 to 170 / <b>130</b> / 1 deg]
008	Roller Ends: Thick 1	
009	Roller Center: Thick 2	[100 to 170 / <b>150</b> / 1 deg]
010	Wait Temp: Center Minus	
011	Wait Temp: Ends Minus	[100 to 170 / <b>140</b> / 1 deg]
012	Roller Ends: Thin	[100 to 170 / <b>145</b> / 1 deg]
013	Roller Center: OHP: Plain	[100 to 170 / <b>150</b> / 1 deg]
014	Roller Ends: OHP: Plain	[100 to 170 / <b>155</b> / 1 deg]
015	Roller Center: OHP: Thick	
016	Roller Ends: OHP: Thick	[100 to 170 / <b>160</b> / 1 deg]
017	Roller Center: Special 1	[100 to 170 / <b>150</b> / 1 deg]
018	Roller Ends: Special 1	[100 to 170 / <b>155</b> / 1 deg]
019	Roller Center: Special 2	[100 to 170 / <b>150</b> / 1 deg]
020	Roller Ends: Special 2	[100 to 170 / <b>155</b> / 1 deg]
021	Roller Center: Special 3	[100 to 170 / <b>150</b> / 1 deg]
022	Roller Ends: Special 3	[100 to 170 / <b>155</b> / 1 deg]
023	Feed Waiting: Plain	Turns the feed waiting mode on or off for each paper type. [0 to 1 / <b>0</b> / 1] 0=Off, 1=On The paper waits at the registration roller
024	Feed Waiting: M-Thick	
025	Feed Waiting: Thick 1	
026	Feed Waiting: Thick 2	

Appendix:  
Service  
Program  
Mode Tables

027	Feed Waiting: Thin	<p>until the fusing temperature reaches the prescribed temperature (adjustable with SP1105-028 to -37).</p> <p>If you enable this feature, also set SP 1105-38 to a convenient value for the customer.</p>
028	Feed Wait: Center Minus: Plain	<p>Adjusts the offset value for each re-load temperature to exit the feed waiting mode.</p> <p>[0 to 60 / <b>0</b> / 1 deg]</p>
029	Feed Wait: Ends Minus: Plain	
030	Feed Wait: Center Minus: M-Thick	
031	Feed Wait: Ends Minus: M-Thick	
032	Feed Wait: Center Minus: Thick 1	
033	Feed Wait: Ends Minus: Thick 1	
034	Feed Wait: Center Minus: Thick 2	
035	Feed Wait: Ends Minus: Thick 2	
036	Feed Wait: Center Minus: Thin	
037	Feed Wait: Ends Minus: Thin	
038	Feed Waiting: Maximum Time	<p>Sets the maximum feed waiting time.</p> <p>[0 to 30 / <b>0</b> / 1 sec]</p> <p>The paper is fed when the time specified with this SP has passed even though the fusing temperature has not reached the prescribed temperature.</p> <p>0: Disabled.</p>

1106	Fusing Temperature Display	
001	Roller Center	Displays the temperature of the fusing unit. [-20 to 250 / <b>0</b> / 1 deg]
002	Roller Ends	
003	Machine Inside at Power On	Displays the temperature inside the machine. [-20 to 250 / <b>0</b> / 1 deg]
004	Machine Inside	

1109	Fusing Nip Band Check	
	Checks the fusing nip band.	
001	Execution	
002*	Idling Rotation Time	[0 to 120 / <b>60</b> / 1 sec]
	Specifies the fusing rotation time before executing SP1109-001.	
003*	Pre-Idling Time	[5 to 30 / <b>10</b> / 1 sec]
	Specifies the time that the paper stops in the fusing unit for measuring the nip.	

1159*	Fusing Jam Detection	
	SC Display	
<p>[0 to 1 / <b>0</b> / 1] 0:OFF, 1:ON</p> <p>This SP setting determines whether SC559 is issued after three paper late jams occur in the fusing unit. After this SP code is turned on, a counter monitors the number of paper late jams that occur in the fusing unit. After the 3rd occurrence of a fusing jam, SC559 is issued and the machine cannot be used until the service technician releases the error.</p> <p><b>Note</b></p> <ul style="list-style-type: none"> <li>Switching the machine off/on does not reset this jam counter. The counter is reset after the cause of the jam has been removed and a sheet of paper successfully passes the fusing exit sensor.</li> </ul>		

1801*	MotorSpeedAdjust	
	Adjusts the speeds of each motor. Each step decreases or increases motor speed in 0.05% increments Regist: Registration motor, Feed: Feed motor, Duplex: Duplex/By-pass motor, Inverter: Duplex inverter motor, Exit: Paper exit motor, Bridge: Bridge unit drive motor, OpcMot: Drum motor, TransferMot: Transfer/Development Motor, FusingMot: Fusing motor, DevPuddleMot: Development Paddle motor	
001	Regist: 90: Thick 2	[-2 to 2 / <b>0.4</b> / 0.05 %]
002	Regist: 154: Thick 1	
003	Regist: 180: Plain	
004	Regist: 230: Plain	
005	Feed: 90: Thick 2	[-2 to 2 / <b>-0.4</b> / 0.05 %]
006	Feed: 154: Thick 1	
007	Feed: 180: Plain	[-2 to 2 / <b>-1</b> / 0.05 %]
008	Feed: 230: Plain	
009	Duplex_CW: 90: Thick 2	[-4 to 4 / <b>0.4</b> / 0.1 %]
010	Duplex_CW: 154: Thick 1	
011	Duplex_CW: 180: Plain	[-4 to 4 / <b>-2.3</b> / 0.1 %]
012	Duplex_CW: 230: Plain	
013	Duplex_CCW: 90: Thick 2	[-4 to 4 / <b>0.4</b> / 0.1 %]
014	Duplex_CCW: 154: Thick 1	
015	Duplex_CCW: 180: Plain	[-4 to 4 / <b>-0.2</b> / 0.1 %]
016	Duplex_CCW: 230: Plain	
017	Inverter_CW: 90: Thick 2	[-4 to 4 / <b>0</b> / 0.1 %]
018	Inverter_CW: 154: Thick 1	



019	Inverter_CW: 180: Plain	
020	Inverter_CW: 230: Plain	
021	Inverter_CCW: 90: Thick 2	
022	Inverter_CCW: 154: Thick 1	
023	Inverter_CCW: 180: Plain	
024	Inverter_CCW: 230: Plain	
025	Exit_CW: 90: Thick 2	
026	Exit_CW: 154: Thick 1	
027	Exit_CW: 180: Plain	
028	Exit_CW: 230: Plain	
029	Bridge: 90: Thick 2	
030	Bridge: 154: Thick 1	
031	Bridge: 180: Plain	
032	Bridge: 230: Plain	
033	OpcMot:90	[-4 to 4 / 0 / 0.01 %]
034	OpcMot:154	
035	OpcMot:180	
036	OpcMot:230	
037	TransferMot:90	
038	TransferMot:154	
039	TransferMot:180	
040	TransferMot:230	
041	FusingMot:90	

Appendix:  
Service  
Program  
Mode Tables

Engine SP Tables-1

042	FusingMot:154	
043	FusingMot:180	
044	FusingMot:230	
045	DevPuddleMot	[-4 to 4 / <b>0</b> / 0.1 %]

1902*	Cleaning Web Setting	
001	Web Consumption	[0 to 120 / <b>0</b> / 1 %]
	Displays the consumed amount of the web roll.	
002	Web Motor Interval	[3 to 130 / <b>6.7</b> / 0.1 sec]
	Adjusts the interval for web motor rotation.	
003	Web Motor Time	[0.3 to 10 / <b>4.2</b> / 0.1 sec]
	Adjusts the rotation time of the web motor.	
004	Web Near End Setting	EU [0 to 100 / <b>90</b> / 1 %] ASIA/NA [0 to 100 / <b>92</b> / 1 %]
	Adjusts the threshold for web near end.	
005	Web Motor Interval: Thick 1	[3 to 130 / <b>11.2</b> / 0.1 sec]
	Adjusts the interval for web motor rotation (thick 1).	
006	Web Motor Interval: Thick 2	[3 to 130 / <b>16.8</b> / 0.1 sec]
	Adjusts the interval for web motor rotation (thick 2).	
007	Paper Interval Time	[0 to 10 / <b>5</b> / 1 sec]
	Adjusts the threshold for paper feeding. When the time between trailing edge detection and leading edge detection is within the value of this setting, the machine determines that the paper is still being fed.	

008	Web Motor Setting: Web End	[0 to 60 / <b>27</b> / 1 sec]
	Adjusts the motor rotation time after the web end.	
009	Web Motor Rotation: Power On	[0 to 10 / <b>0</b> / 1 times]
	Adjusts the number of web motor rotations at the re-load state.	
010	Web Motor Interval: Pre-idle	[0 to 30 / <b>0</b> / 1 sec]
	Adjusts the motor waiting time after the fusing motor idling.	
011	Web Motor Rotation: Pre-idle	[0 to 10 / <b>0</b> / 1 times]
	Adjusts the number of web motor rotations at the fusing idling state.	

1903	Cleaning Web Setting	
001	Total Paper Counter	[0 to 999999999 / <b>0</b> / 1 sec]
	Displays the total paper feeding time.	
002	Total Web Motor Drive Time	[0 to 999999999 / <b>0</b> / 1 sec]
	Displays the total time of web motor rotation.	

1904	FusingDuplex Set	
001	Set 0:Off/1:On	[0 or 1 / <b>0</b> / 1]
	0:Off/1:On	
002	Aft Reload ChgTime	[0 to 999 / <b>20</b> / 1 sec]

Appendix:  
Service  
Program  
Mode Tables

1907*	Paper Feed Timing Adj. (DFU)	
001	Feed Solenoid ON: Plain	[-10 to 40 / <b>0</b> / 2.5 mm]
002	Feed Solenoid ON: Thick	
003	Feed Solenoid OFF: Plain	[-10 to 10 / <b>0</b> / 1 mm]
004	Feed Solenoid OFF: Thick	
005	Feed Clutch ON: Plain	
006	Feed Clutch ON: Thick	
007	Stop Position before Inverter	
008	Stop Position after Inverter	
009	Re-Feed Stop Position	
010	By-pass Solenoid OFF	[0 to 40 / <b>0</b> / 1 mm]
011	By-pass Solenoid ON	[0 to 1 / <b>1</b> / 1 mm]
012	By-pass Feed Clutch ON	[-10 to 10 / <b>0</b> / 1 mm]
013	Exit Roller: Shift: 180	
014	Exit Roller: Shift: 230	
015	Exit: Junction Solenoid ON	
016	Exit: Junction Solenoid OFF	
017	Bridge: Junction Solenoid ON	
018	Bridge: Junction Solenoid OFF	
019	1-Bin: Junction Solenoid ON	
020	1-Bin: Junction Solenoid OFF	
021	Shift Motor ON	[-1 to 1 / <b>0</b> / 0.1 mm]
022	Re-Feed Stop Position S Size	[-10 to 10 / <b>0</b> / 1 mm]

1908*	F1 Plate Adj (DFU)	
	Adjust the paper feed timing for the optional paper feed unit.	
001	A3,DLT:100%	[-10 to 10 / 0 / 1 mm]
	Adjust the paper feed timing for plain paper.	
002	A3,DLT:70%	[-10 to 10 / 0 / 1 mm]
	Adjust the paper feed timing for thick paper.	

1916*	CPM Down Setting	
	When this machine gets a sequence of coping/printing jobs, the machine uses CPM down mode to prevent the fusing temperature from becoming too low.	
001	Temp.: Plain	Adjusts the thresholds for each environmental condition (between Low and Medium). [10 to 23 / 17 / 1 deg]
002	Temp.: M-Thick	
003	Temp.: Thick 1	
004	Temp.: Thick 2	
005	Temp.: Thin	
006	ON/OFF: Low: Plain	Turns on or off the CPM down setting for each paper type and ambient temperature. [0 to 1 / 0 / 1 ] 0= Off, 1= On
007	ON/OFF: Low: M-Thick	
008	ON/OFF: Low: Thick 1	
009	ON/OFF: Low: Thick 2	
010	ON/OFF: Low: Thin	
011	ON/OFF: Medium: Plain	
012	ON/OFF: Medium: M-Thick	

Appendix:  
Service  
Program  
Mode Tables

013	ON/OFF: Medium:: Thick 1	
014	ON/OFF: Medium: Thick 2	
015	ON/OFF: Medium: Thin	
016	Waiting Time: Low: Plain	<p>Adjusts the threshold time to enter the CPM down mode.</p> <p>[0 to 180 / <b>60</b> / 1 sec]</p> <p>The machine determines whether the CPM down mode is activated or not after the time specified with these SPs has passed.</p>
017	Waiting Time: Low: M-Thick	
018	Waiting Time: Low: Thick 1	
019	Waiting Time: Low: Thick 2	
020	Waiting Time: Low: Thin	
021	Waiting Time: Medium: Plain	
022	Waiting Time: Medium: M-Thick	
023	Waiting Time: Medium: Thick 1	
024	Waiting Time: Medium: Thick 2	
025	Waiting Time: Medium: Thin	
026	Temp.: Low: Plain	<p>Adjusts the threshold temperature of the fusing unit to enter the CPM down mode.</p> <p>[100 to 200 / <b>120</b> / 1 deg]</p> <p>If the temperature of the fusing unit is less than the temperature specified with these SPs, the machine changes the CPM (adjustable with SP1916-36 to -45).</p>
027	Temp.: Low: M-Thick	
028	Temp.: Low: Thick 1	
029	Temp.: Low: Thick 2	
030	Temp.: Low: Thin	
031	Temp.: Medium: Plain	
032	Temp.: Medium: M-Thick	
033	Temp.: Medium: Thick 1	

034	Temp.: Medium: Thick 2	
035	Temp.: Medium: Thin	
036	CPM: Low: Plain	Adjusts the CPM in the CPM down mode. [30 to 45 / <b>45</b> / 5 cpm]
037	CPM: Low: M-Thick	Adjusts the CPM in the CPM down mode. [30 to 45 / <b>45</b> / 5 cpm]
038	CPM: Low: Thick 1	Adjusts the CPM in the CPM down mode. [5 to 25 / <b>25</b> / 5 cpm]
039	CPM: Low: Thick 2	Adjusts the CPM in the CPM down mode. [5 to 15 / <b>15</b> / 5 cpm]
040	CPM: Low: Thin	Adjusts the CPM in the CPM down mode. [30 to 45 / <b>45</b> / 5 cpm]
041	CPM: Medium: Plain	
042	CPM: Medium: M-Thick	
043	CPM: Medium: Thick 1	Adjusts the CPM in the CPM down mode. [5 to 25 / <b>25</b> / 5 cpm]
044	CPM: Medium: Thick 2	Adjusts the CPM in the CPM down mode. [5 to 15 / <b>15</b> / 5 cpm]
045	CPM: Medium: Thin	Adjusts the CPM in the CPM down mode. [30 to 45 / <b>45</b> / 5 cpm]

Appendix:  
Service  
Program  
Mode Tables

Engine SP Tables-1

1930*	OnOff Time Adjust	
001	On Time Adjust	[0 to 100 / <b>40</b> / 10 msec]
	Adjusts the Off-On interval of the transfer belt contact motor. ("On" means that the transfer belt is in contact with the drum.)	
002	Off Time Adjust	[0 to 100 / <b>20</b> / 10 msec]
	Adjusts the On-Off interval of the transfer belt contact motor. ("Off" means that the transfer belt is away from the drum.)	

1950*	Tray Lock at Jam	[0 or 1 / <b>0</b> / 1 ] 0= OFF, 1= ON
	<b>Not used</b>	



### 3.3 ENGINE SP TABLES-2

#### 3.3.1 SP2-XXX: DRUM

2001*	Charge Bias	
001	Setting (Copying)	[1000 to 2000 / <b>1500</b> / 10 V]
	Adjusts the voltage applied to the charge roller for copying.	
002	Setting (P Pattern)	[0 to 700 / <b>250</b> / 10 V]
	Adjusts the voltage applied to the charge roller when making the VSDP ID sensor pattern (for charge roller voltage correction). The actual charge roller voltage is this value plus the value of SP2001-1.	

2005*	Bias Control	
001	Bias Correction 1	[0.1 to 1 / <b>0.85</b> / 0.05 step]
	Adjusts the lower threshold value for the charge roller correction. When the value of VSDP/VSG is greater than this value, the charge roller voltage increases by 30 V (e.g., from -500 to -530).	
002	Bias Correction 2	[0.1 to 1 / <b>0.9</b> / 0.05 step]
	Adjusts the upper threshold value for the charge roller correction. When the value of VSDP/VSG is greater than this value, the charge roller voltage decreases by 30 V (absolute value).	
003	Bias Adjustment 1	[1000 to 2000 / <b>1500</b> / 10 vol]
	Adjusts the lower limit value for charge roller voltage correction.	
004	Bias Adjustment 2	[1000 to 2000 / <b>2000</b> / 10 vol]
	Adjusts the upper limit value for charge roller voltage correction.	
005	Bias Adjustment 3	[0 to 100 / <b>30</b> / 10 vol]
	Adjusts the correction voltage adjustment step size.	

2102*	Magnification Adjustment	
001	Main Scan	[-2 to 2 / <b>0</b> / 0.1 %]
	Adjusts the magnification in the main scan direction for copy mode and printer mode.	
002	Sub Scan	[-1 to 1 / <b>0</b> / 0.1%]
	Adjusts the magnification in the sub scan direction for copy mode and printer mode.	

2103*	Erase Margin Adjustment	
	Adjusts the erase margin by deleting image data at the margins. L Size: 297.1 mm or more (length) M Size: 216.1 to 297 mm (length) S Size: 216 mm or less (length)	
001	Leading Edge	[0 to 9 / <b>3</b> / 0.1mm]
002	Trailing Edge	
003	Left	[0 to 9 / <b>2</b> / 0.1mm]
004	Right	
005	Duplex Trail.: L Size: Plain	[0 to 4 / <b>1</b> / 0.1mm]
006	Duplex Trail.: M Size: Plain	[0 to 4 / <b>0.8</b> / 0.1mm]
007	Duplex Trail.: S Size: Plain	[0 to 4 / <b>0.6</b> / 0.1mm]
008	Duplex Left: Plain	[0 to 1.5 / <b>0.3</b> / 0.1mm]
009	Duplex Right: Plain	
010	Duplex Trail.: L Size: Thick	[0 to 4 / <b>0.8</b> / 0.1mm]
011	Duplex Trail.: M Size: Thick	[0 to 4 / <b>0.6</b> / 0.1mm]
012	Duplex Trail.: S Size: Thick	[0 to 4 / <b>0.4</b> / 0.1mm]
013	Duplex Left: Thick	[0 to 1.5 / <b>0.1</b> / 0.1mm]
014	Duplex Right: Thick	

2105*	LD Power Adjustment(DFU)	
	Adjusts the LD power for each mode. Each LD power setting is decided by the process control.	
001	LD1: Copy	[-50 to 79 / <b>5</b> /1 ]
002	LD2: Copy	
003	LD1: Printer/Fax	[-50 to 79 / <b>5</b> /1 ]
004	LD2: Printer/Fax	

2106*	POL REV TIME (Polygon motor rotation time)	
001	PRE TIME	[0 to 60 / <b>10</b> /1 sec]
	Adjusts the time of polygon motor rotation before a job. If this is set to "0", this SP is not activated.	
002	POST TIME	[0 to 60 / <b>0</b> /1 sec]
	Adjusts the time of the polygon motor rotation after a job. If this is set to "0", the polygon motor never switches off in standby mode. However, if the machine enters the energy saver mode, the polygon motor will ignore the zero setting and switch itself off.	

Appendix:  
Service  
Program  
Mode Tables

2109	Test Pattern	
001	Pattern Selection	[0 to 24 / <b>0</b> / 1 ] Test pattern of the GAVD
	0: None 1: Vertical Line (1 dot) 2: Vertical Line (2 dot) 3: Horizontal Line (1 dot) 4: Horizontal Line (2 dot) 5: Grid Vertical Line 6: Grid Horizontal Line 7: Grid pattern small 8: Grid Pattern Large 9: Argyle Pattern Small 10: Argyle Pattern Large 11: Independent pattern (1 dot) 12: Independent Pattern (2 dot)	13: Independent Pattern (4 dot) 14: Trimming Area 15: Hound's Tooth Check (Vertical) 16: Hound's Tooth Check (Horizontal) 17: Black Band (Horizontal) 18: Black band ( Vertical) 19: Checker Flag Pattern 20: Grayscale (Vertical Margin) 21: Grayscale (Horizontal Margin) 22: Two Beam Density Pattern 23: Full Dot Pattern 24:All white Pattern
002	Density	[0 to 15 / <b>15</b> / 1 ] Set the density of the test pattern which is output in SP2109-001. This SP is not used for the Grayscale patterns.

2201*	Development Bias Adjustment	
001	Development Bias	[200 to 700 / <b>560</b> / 10V ]
	Adjusts the development bias for copying. Use as a temporary measure to correct faint copies from an aging drum.	
002	ID Sensor Pattern	[200 to 700 / <b>400</b> / 10V ]
	Adjusts the development bias for the ID sensor pattern for VSP	

2207	Forced Toner Supply	
	Forces the toner bottle to supply toner at 1-second intervals for up to 30 seconds. To start, press [EXECUTE].	

2208*	Toner Supply Mode	[0: Sensor, 1: pixel ]
	<p>Selects the toner mode.</p> <p>If you select "1", SP2-209-002 should be set to its default value. Use image pixel count modes only as a temporary measure if the ID or TD sensor is defective.</p>	

2209*	Toner Supply Rate	
001	Toner Rate	[10 to 800 / <b>60 mg/s</b> / 5 mg ]
	<p>Sets the amount of toner supplied every second by the toner supply motor. The length of time the motor remains on is determined by the data read by the TD sensor and ID sensor.</p> <p>Increasing this value reduces the toner supply clutch on time. Use a lower value if the user tends to make lots of copies that have a high proportion of black.</p>	
002	Correction Data	[25 to 300 / <b>300</b> / 25 ]
	<p>Displays the toner supply correction coefficient (K). It can also be used to adjust K, but the value is changed again when VT is measured for the next copy.</p> <p>The toner supply rate depends on the amount of toner in the toner bottle. This change is corrected using this coefficient. This SP can be used to check the toner supply condition. The lower the value of K, the lower the toner density</p>	

Appendix:  
Service  
Program  
Mode Tables

2210*	P Pattern Cycle	
	Sets the interval between ID sensor pattern prints.	
001*	Job Page Count	[0 to 200 / <b>10</b> / 1 sheet]
	Sets the interval between ID sensor pattern printing. For users that do not make many copies daily, set a smaller interval to compensate for the effects of seasonal and weather changes.	
002*	Forced Page Count	[2 to 999 / <b>100</b> / 1 sheet]
	Sets the interval between ID sensor pattern printing. Forces creation of the ID sensor pattern to prevent low density copies for customers who use the copier for long copy jobs.	

2213*	Toner End Setting	
	<p>Selects the detection type for toner end. [0 to 2 / <b>0</b> / 1 step] [0: 90 copies, 1: No copies, 2: 10 copies]</p> <p><b>Note</b></p> <ul style="list-style-type: none"> <li>▪ 90 copies: Toner end is determined if a low density image (<math>V_{ref} &lt; V_t(10)</math>) is detected 90 times after toner near end.</li> <li>▪ If "1" is selected, the machine stops printing when the TD sensor output drops below the prescribed level.</li> <li>▪ Select 1 or 2 if the customer normally makes copies of very high density.</li> </ul>	

2220*	Vref Setting	
	<p>Adjusts the TD sensor reference voltage (Vref). Change this value after replacing the development unit with another development unit that contains toner.</p> <p>[1 to 5 / 4 / 0.01 ]</p> <ol style="list-style-type: none"> <li>1. Check the value of SP2-220 in both the machine containing the test unit and the machine that you are going to move it to.</li> <li>2. Install the test development unit, and then input the VREF for this unit into SP2-220.</li> <li>3. After the test, put back the old development unit, and change SP2-220 back to the original value.</li> </ol>	

2221*	Reverse Interval Drum,Transfer	[0 to 2000 / 0 / 1 sheets]
	<p>Adjusts the threshold for the reverse rotation of the drum and development/transfer motors. This helps the drum and transfer belt cleaning operations. This reverse rotation will interrupt a multiple printing job.</p>	

2223*	Vt Display	
001	Current	[0 to 5 / 4 / 0.01]
	Displays the TD sensor output voltage for the immediately previous copy.	
002	Average 10 copies	[0 to 5 / 4 / 0.01]
	Displays the average of the most recent TD sensor outputs (from the previous 10 copies).	
003	Rate of Change	[-10000 to 10000 / 0 / 1]
	Displays the rate of change in the TD sensor output.	
004	GAIN	[0 to 255 / 0 / 1]
	Displays the GAIN value used to calculate the on time for the toner supply motor.	

005	Image Pixel Count	[0 to 255 / <b>0</b> / 1]
	Displays the image pixel count.	
2228*	Developer Lot	
	Displays the lot number of the developer. (The lot number is embossed on the top edge of the developer pack.)	
2301*	Transfer Current Adjustment	
	If the transfer current of image area is set highly than normal, the print image is easily come out. If the leading transfer current is set as same, the black line is come out due to exfoliation leave.	
001	Image Area: 1st Side	[10 to 100 / <b>45</b> / 1 $\mu$ A]
	Adjusts the transfer current for printing the first side of the paper	
002	Image Area: 2nd Side	[10 to 100 / <b>40</b> / 1 $\mu$ A]
	Adjusts the transfer current for printing the second side of the paper	
003	Leading Edge: 1st Side	[10 to 100 / <b>20</b> / 1 $\mu$ A]
	Adjusts the transfer current for copying at leading edge the first side of the paper. Increase the current to separate the paper from the drum properly in high humidity and high temperature conditions.	
004	Leading Edge: 2nd Side	[10 to 100 / <b>20</b> / 1 $\mu$ A]
	Adjusts the transfer current for copying at leading edge the second side of the paper. Increase the current to separate the paper from the drum properly in high humidity and high temperature conditions.	
005	By-pass: Image Area	[10 to 100 / <b>45</b> / 1 $\mu$ A]
	Adjusts the transfer current for copying from the by-pass tray. If the user normally feeds thicker paper from the bypass tray, use a higher setting.	



006	By-pass: Leading Edge	[10 to 100 / <b>20</b> / 1 $\mu$ A ]
	Adjusts the transfer current for copying at the leading edge of paper fed from the by-pass tray. Increase the current to separate the paper from the drum properly in high humidity and high temperature conditions.	
008	No Image Area ( <b>SSP</b> )	[10 to 100 / <b>15</b> / 1 $\mu$ A ]
	Adjusts the transfer current for copying.	

2309*	Current: Paper Size Correction ( <b>SSP</b> )	
001	Paper Lower Width (a)	[1 to 150 / <b>150</b> / 1 mm ]
	Adjusts the lower paper width threshold for the transfer current, charge voltage, and development bias corrections. Use this SP when an image problem (e.g., insufficient toner transfer) occurs with a small width paper. If the paper width is smaller than this value, the transfer current will be multiplied by the factor in SP2-309-3 (paper tray) or SP2-309-5 (by-pass).	
002	Paper Upper Width (a)	[151 to 296 / <b>216</b> / 1 mm ]
	Adjusts the upper paper width threshold for the transfer current, charge voltage, and development bias corrections. As for SP2-309-1, but the factors are in SP2-309-4 (paper tray) and SP2-309-6 (by-pass).	
003	Paper Tray: Plain (alpha)	[1 to 3 / <b>1</b> / 0.1 ]
	Adjusts the transfer current correction coefficient used if the paper width is less than the setting of SP2-309-1.	
004	Paper Tray: Plain (beta)	[1 to 3 / <b>1</b> / 0.1 ]
	Adjusts the transfer current correction coefficient used if the paper width is less than the setting of SP2-309-2.	
005	By-pass: Plain (gamma)	[1 to 3 / <b>1.1</b> / 0.1 ]
	Adjusts the transfer current correction coefficient used if the paper width is less than the setting of SP2-309-1.	

Appendix:  
 Service  
 Program  
 Mode Tables

Engine SP Tables-2

006	By-pass: Plain (delta)	[1 to 3 / <b>1.1</b> / 0.1 ]
	Adjusts the transfer current correction coefficient used if the paper width is less than the setting of SP2-309-2.	
007	Paper Tray: Thick 1 (alpha)	[1 to 3 / <b>1</b> / 0.1 ]
008	Paper Tray: Thick 1 (beta)	
009	By-pass: Thick 1 (gamma)	[1 to 3 / <b>1.1</b> / 0.1 ]
010	By-pass: Thick 1 (delta)	
011	Paper Tray: Thick 2 (alpha)	[1 to 3 / <b>1.1</b> / 0.1 ]
012	Paper Tray: Thick 2 (beta)	
013	By-pass: Thick 2 (gamma)	[1 to 3 / <b>1.5</b> / 0.1 ]
014	By-pass: Thick 2 (delta)	
015	Paper Tray: M-Thick (alpha)	[1 to 3 / <b>1</b> / 0.1 ]
016	Paper Tray: M-Thick (beta)	
017	By-pass: M-Thick (gamma)	[1 to 3 / <b>1.1</b> / 0.1 ]
018	By-pass: M-Thick (delta)	
019	Paper Tray: Thin (alpha)	[1 to 3 / <b>1</b> / 0.1 ]
020	Paper Tray: Thin (beta)	
021	By-pass: Thin (gamma)	[1 to 3 / <b>1.1</b> / 0.1 ]
022	By-pass: Thin (delta)	
023	Paper Tray: Special 1 (alpha)	[1 to 3 / <b>1</b> / 0.1 ]
024	Paper Tray: Special 1 (beta)	
025	By-pass: Special 1 (gamma)	[1 to 3 / <b>1.1</b> / 0.1 ]
026	By-pass: Special 1 (delta)	
027	Paper Tray: Special 2 (alpha)	[1 to 3 / <b>1</b> / 0.1 ]
028	Paper Tray: Special 2 (beta)	

029	By-pass: Special 2 (gamma)	[1 to 3 / <b>1.1</b> / 0.1 ]
030	By-pass: Special 2 (delta)	
031	Paper Tray: Special 3 (alpha)	[1 to 3 / <b>1</b> / 0.1 ]
032	Paper Tray: Special 3 (beta)	
033	By-pass: Special 3 (gamma)	[1 to 3 / <b>1.1</b> / 0.1 ]
034	By-pass: Special 3 (delta)	

2310*	Current: Paper Type Correction ( <b>SSP</b> )	
	Adjusts the transfer current for each paper type. If the transfer current of the image area is set higher than normal, the print image easily comes out. If the leading edge transfer current is set the same, black lines come out.	
001	Image 1st Side: Thick 1	[10 to 100 / <b>18</b> / 1 $\mu$ A]
	Adjusts the transfer current for the first side of the paper (Thick 1).	
002	Leading Edge 1st Side: Thick 1	[10 to 100 / <b>15</b> / 1 $\mu$ A]
	Adjusts the transfer current for the leading edge of the first side of the paper. Increase the current to separate the paper from the drum properly in high humidity and high temperature conditions (Thick 1).	
003	Image 2nd Side: Thick 1	[10 to 100 / <b>18</b> / 1 $\mu$ A]
	Adjusts the transfer current for the second side of the paper (Thick 1).	
004	Leading Edge 2nd Side: Thick 1	[10 to 100 / <b>15</b> / 1 $\mu$ A]
	Adjusts the transfer current for the leading edge of the second side of the paper (Thick 1). Increase the current to separate the paper from the drum properly in high humidity and high temperature conditions.	

Appendix:  
Service  
Program  
Mode Tables

005	Image: Thick 2	[10 to 100 / <b>18</b> / 1 $\mu$ A]
	Adjusts the transfer current (Thick 2).	
006	Leading Edge: Thick 2	[10 to 100 / <b>15</b> / 1 $\mu$ A]
	Adjusts the transfer current for the leading edge of paper (Thick 2). Increase the current to separate the paper from the drum properly in high humidity and high temperature conditions.	
007	Image: OHP	[10 to 100 / <b>20</b> / 1 $\mu$ A]
	Adjusts the transfer current (OHP).	
008	Leading Edge: OHP	[10 to 100 / <b>20</b> / 1 $\mu$ A]
	Adjusts the transfer current for the leading edge of paper (OHP). Increase the current to separate the paper from the drum properly in high humidity and high temperature conditions.	
009	Image: Envelope	[10 to 100 / <b>20</b> / 1 $\mu$ A]
	Adjusts the transfer current (Envelopes).	
010	Leading Edge: Envelope	[10 to 100 / <b>20</b> / 1 $\mu$ A]
	Adjusts the transfer current for the leading edge of paper (Envelopes). Increase the current to separate the paper from the drum properly in high humidity and high temperature conditions.	
011	Image 1st Side: M-Thick	[10 to 100 / <b>32</b> / 1 $\mu$ A]
	Adjusts the transfer current for the first side of the paper (M-Thick).	
012	Leading Edge 1st Side: M-Thick	[10 to 100 / <b>20</b> / 1 $\mu$ A]
	Adjusts the transfer current for the leading edge of the first side of the paper (M-Thick). Increase the current to separate the paper from the drum properly in high humidity and high temperature conditions.	

013	Image 2nd Side: M-Thick	[10 to 100 / <b>32</b> / 1 $\mu$ A]
	Adjusts the transfer current for the second side of the paper (M-Thick).	
014	Leading Edge 2nd Side: M-Thick	[10 to 100 / <b>20</b> / 1 $\mu$ A]
	Adjusts the transfer current for the leading edge of the second side of the paper (M-Thick). Increase the current to separate the paper from the drum properly in high humidity and high temperature conditions.	
015	Image 1st Side: Special 1	[10 to 100 / <b>45</b> / 1 $\mu$ A]
	Adjusts the transfer current for the first side of the paper (Special 1).	
016	Leading Edge 1st Side: Special 1	[10 to 100 / <b>20</b> / 1 $\mu$ A]
	Adjusts the transfer current for the leading edge of the first side of the paper (Special 1). Increase the current to separate the paper from the drum properly in high humidity and high temperature conditions.	
017	Image 2nd Side: Special 1	[10 to 100 / <b>40</b> / 1 $\mu$ A]
	Adjusts the transfer current for the second side of the paper (Special 1).	
018	Leading Edge 2nd Side: Special 1	[10 to 100 / <b>20</b> / 1 $\mu$ A]
	Adjusts the transfer current for the leading edge of the second side of the paper (Special 1). Increase the current to separate the paper from the drum properly in high humidity and high temperature conditions.	
019	Image 1st Side: Special 2	[10 to 100 / <b>32</b> / 1 $\mu$ A]
	Adjusts the transfer current for the first side of the paper (Special 2).	
020	Leading Edge 1st Side: Special 2	[10 to 100 / <b>32</b> / 1 $\mu$ A]
	Adjusts the transfer current for the leading edge of the first side of the paper (Special 2). Increase the current to separate the paper from the drum properly in high humidity and high temperature conditions.	

Appendix:  
Service  
Program  
Mode Tables

021	Image 2nd Side: Special 2	[10 to 100 / <b>32</b> / 1 $\mu$ A]
	Adjusts the transfer current for the second side of the paper (Special 2).	
022	Leading Edge 2nd Side: Special 2	[10 to 100 / <b>32</b> / 1 $\mu$ A]
	Adjusts the transfer current for the leading edge of the second side of the paper (Special 2). Increase the current to separate the paper from the drum properly in high humidity and high temperature conditions.	
023	Image 1st Side: Special 3	[10 to 100 / <b>32</b> / 1 $\mu$ A]
	Adjusts the transfer current for the first side of the paper (Special 3).	
024	Leading Edge 1st Side: Special 3	10 to 100 / <b>32</b> / 1 $\mu$ A]
	Adjusts the transfer current for the leading edge of the first side of the paper (Special 3). Increase the current to separate the paper from the drum properly in high humidity and high temperature conditions.	
025	Image 2nd Side: Special 3	[10 to 100 / <b>32</b> / 1 $\mu$ A]
	Adjusts the transfer current for the second side of the paper (Special 3).	
026	Leading Edge 2nd Side: Special 3	[10 to 100 / <b>32</b> / 1 $\mu$ A]
	Adjusts the transfer current for the leading edge of the second side of the paper (Special 3). Increase the current to separate the paper from the drum properly in high humidity and high temperature conditions.	

2602*	PTL Control ( <b>SSP</b> )	
	Use this SP when an image problem occurs caused by the pick-off pawls. This SP is for line speeds of 230 or 180 mm/s. Set PTL control (SP2603-001) to "1: ON" after installing the PTL. If PTL control is set to ON, black lines come out. Set SP2911-002 (or 005, 008, 011) to "20" when using the PTL.	
001	1st Side: OFF/ON	[0 to 1 / 0 / 1]
	Sets the PTL control setting for printing the first side of the paper.	
002	1st Side: OFF Timing	[-10 to 10 / 2 / 1]
	Sets the PTL control time for printing the first side of the paper when SP2602-001 is set to "1".	
003	2nd Side: OFF/ON	[0 to 1 / 0 / 1]
	Sets the PTL control setting for printing the second side of the paper.	
004	2nd Side: OFF Timing	[-10 to 10 / 2 / 1]
	Sets the PTL control time for printing the second side of the paper when SP2602-003 is set to "1".	

2603*	PTL Control: 154 mm/s ( <b>SSP</b> )	
	Use this SP when an image problem occurs caused by the pick-off pawls. This SP is for the line speed of 154 mm/s. Set PTL control (SP2603-001) to "1: ON" after installing the PTL. If the PTL control is set to ON, black lines come out. Set SP2911-002 (or 005, 008, 011) to "20" when using the PTL.	
001	1st Side: OFF/ON	[0 to 1 / 0 / 1]
	Sets the PTL control setting for printing the first side of the paper.	

002	1st Side: OFF Timing	[-10 to 10 / <b>2</b> / 1]
	Sets the PTL control time for printing the first side of the paper when SP2602-001 is set to "1".	
003	2nd Side: OFF/ON	[0 to 1 / <b>0</b> / 1]
	Sets the PTL control setting for printing the second side of the paper.	
004	2nd Side: OFF Timing	[-10 to 10 / <b>2</b> / 1]
	Sets the PTL control time for printing the second side of the paper when SP2602-003 is set to "1".	

2604*	PTL Control: 90 mm/s ( <b>SSP</b> )	
	Use this SP when an image problem occurs caused by the pick-off pawls. This SP is for the line speed of 90 mm/s. Set PTL control (SP2603-001) to "1: ON" after installing the PTL. If the PTL control is set to ON, black lines come out. Set SP2911-002 (or 005, 008, 011) to "20" when using the PTL.	
001	1st Side: OFF/ON	[0 to 1 / <b>0</b> / 1]
	Sets the PTL control setting for printing the first side of the paper.	
002	1st Side: OFF Timing	[-10 to 10 / <b>2</b> / 1]
	Sets the PTL control time for printing the first side of the paper when SP2602-001 is set to "1".	
003	2nd Side: OFF/ON	[0 to 1 / <b>0</b> / 1]
	Sets the PTL control setting for printing the second side of the paper.	
004	2nd Side: OFF Timing	[-10 to 10 / <b>2</b> / 1]
	Sets the PTL control time for printing the second side of the paper when SP2602-003 is set to "1".	



2801*	TD Sensor Initial Setting	Initialization
	<p>Performs the TD sensor initial setting and allows the service technician to enter the lot number of the developer. (The lot number is embossed on the edge of the developer package.) This SP mode controls the voltage applied to the TD sensor to make the TD sensor output about 3.0 V. Press "Execute" to start. After finishing this, the TD sensor output voltage is displayed.</p> <p>Use this mode only after installing the machine, changing the TD sensor, or adding new developer.</p>	

2802*	TD Sensor Manual Setting	
	Allows you to adjust the TD sensor output manually for the following.	
001	VTS	[1 to 5 / <b>4.78</b> / 0.01vol ]
	<p>Adjusts the TD sensor output (VT).</p> <p>Change this value after replacing the development unit with another one that already contains toner. For example, when using a development unit from another machine for test purposes. To adjust VT, use a similar procedure as for SP2-220.</p>	
002	VTMAX	[1 to 5 / <b>4.78</b> / 0.01vol ]
	Adjusts the maximum value for SP2802 1.	
003	VTMIN	[1 to 5 / <b>1</b> / 0.01vol ]
	Adjusts the minimum value for SP2802 1.	

2805	Process Setting	
	<p>Performs the developer initialization. Press "Execute" to start. This SP should be performed after doing SP2801 at installation and after replacing the drum.</p>	

Appendix:  
Service  
Program  
Mode Tables

2810	Grayscale Setting	
	Initializes the LD power setting. This SP should be done after replacing the drum.	

2812*	Drum Reverse Rotation ( <b>SSP</b> )	
001	Reverse time	[0 to 9 / <b>4</b> / 1 ]
	Sets the reverse time of the drum motor after the end of a job.	
002	Interval time	[0 to 19 / <b>9</b> / 1 ]
	Sets the waiting time of the drum motor reverse after the end of a job.	

2911*	Transfer Current On/Off Timing ( <b>SSP</b> )	
001	La (On Timing)	[-20 to 20 / <b>0</b> / 1 mm]
	Adjust the timing to turn on the transfer current for the leading edge.	
002	Lb (Switch Timing)	[0 to 30 / <b>10</b> / 1 mm]
	Adjust the timing to switch transfer current from the leading edge to the image area.	
003	Lc (Off Timing)	[-20 to 20 / <b>-5</b> / 1 mm]
	Adjust the timing to turn off the transfer current for the image area.	
004	La (On Timing): Special 1	[-20 to 20 / <b>0</b> / 1 mm]
	Adjust the timing to turn on the transfer current for the leading edge (Special 1).	
005	Lb (Switch Timing): Special 1	[0 to 30 / <b>10</b> / 1 mm]
	Adjust the timing to switch transfer current from the leading edge to the image area (Special 1).	

006	Lc (Off Timing): Special 1	[-20 to 20 / -5 / 1 mm]
	Adjust the timing to turn off the transfer current for the image area (Special 1).	
007	La (On Timing): Special 2	[-20 to 20 / 0 / 1 mm]
	Adjust the timing to turn on the transfer current for the leading edge (Special 2).	
008	Lb (Switch Timing): Special 2	[0 to 30 / 10 / 1 mm]
	Adjust the timing to switch transfer current from the leading edge to the image area (Special 2).	
009	Lc (Off Timing): Special 2	[-20 to 20 / -5 / 1 mm]
	Adjust the timing to turn off the transfer current for the image area (Special 2).	
010	La (On Timing): Special 3	[-20 to 20 / 0 / 1 mm]
	Adjust the timing to turn on the transfer current for the leading edge (Special 2).	
011	Lb (Switch Timing): Special 3	[0 to 30 / 10 / 1 mm]
	Adjust the timing to switch transfer current from the leading edge to the image area (Special 2).	
012	Lc (Off Timing): Special 3	[-20 to 20 / -5 / 1 mm]
	Adjust the timing to turn off the transfer current for the image area (Special 2).	

2912*	Transfer Reverse Rotation	
002	Interval	[0 to 10 / 3 / 1 ]
	Sets the reverse time of the transfer/development motor after the end of a job.	

Appendix:  
Service  
Program  
Mode Tables

2914*	Paper Setting	
001	C-alpha	[0 to 400 / <b>150</b> / 10vol ]
	<p>Adjusts the charge roller voltage used when paper with a small width is fed from the by-pass tray. The paper width below which the correction starts depends on the value of SP2-309-1.</p> <p>Use this SP when an image problem (such as white spots at the center of black dots or breaks in thin black lines) occurs when paper with a small width is fed from the by-pass feed tray.</p>	
002	C-beta	[0 to 400 / <b>0</b> / 10vol ]
	<p>Adjusts the charge roller voltage used when paper with a small width is fed from the by-pass tray. The paper width below which the correction starts depends on the value of SP2-309-2.</p> <p>Use this SP when an image problem (see 2-914-1) occurs when paper with a small width is fed from the by-pass feed tray.</p>	
003	B-gamma	[0 to 300 / <b>200</b> / 10vol ]
	<p>Adjusts the development bias used when paper with a small width is fed from the by-pass tray. The paper width below which the correction starts depends on the value of SP2-309-1.</p> <p>Use this SP when an image problem (see 2-914-1) occurs when paper with a small width is fed from the by-pass feed tray.</p>	
004	B-delta	[0 to 300 / <b>50</b> / 10vol ]
	<p>Adjusts the development bias used when paper with a small width is fed from the by-pass tray. The paper width below which the correction starts depends on the value of SP2-309-2.</p> <p>Use this SP when an image problem (see 2-914-1) occurs when paper with a small width is fed from the by-pass feed tray.</p>	

2940*	Toner consump. <b>(SSP)</b>	
001	[0: OFF 1: ON]	[0 to 1 / <b>1</b> / 1]
	If this SP is set to ON, the toner bottle consumes toner when SP2801 (TD Sensor Initial Setting) is executed. This prevents image offset.	
002	Setting	[0 to 1 / <b>0.06</b> / 0.01]
	Specifies the threshold value for the toner consumption mode if SP2940-001 is set to ON.	

2960*	Toner Overflow Sensor	[ <b>0 = OFF</b> , 1= ON]
	Selects whether or not the toner overflow sensor is activated.	

2964*	Trans Cleaning Blade Forming <b>(SSP)</b>	
	<p>Applies a pattern of toner to the transfer belt at a defined interval between sheets on the transfer belt in order to reduce friction between the belt surface and the cleaning blade.</p> <p>Under conditions of high temperature and high humidity, the density control feature may reduce the amount of toner, which also reduces the amount of toner on the surface of the transfer belt. With less toner on the belt, the friction between the belt and the blade increases, and could cause the blade to bend or scour the surface of the belt.</p>	
001	0: OFF, 1: ON	[0 to 1 / <b>0</b> / 1]
002	Pattern Interval	[1 to 100 / <b>15</b> / 1 sheet]
003	Pattern Number	[1 to 3 / <b>1</b> / 1 line]
004	Pattern LD Power	[0 to 15 / <b>2</b> / 1]

Appendix:  
Service  
Program  
Mode Tables

2972*	Grayscale Limit ( <b>SSP</b> )	
	Controls the halftone density level to prevent deterioration of the OPC. The halftone density is detected by the ID sensor, and the machine adjusts the intensity of the LD beam according to the upper/lower limit setting.	
001	Upper Limit	[0 to 100 / <b>63</b> / 1vol ]
	Defines the upper limit for grayscale. A larger value allows a wider range of halftones at the pale end of the scale. If the image contains pale areas with fuzzy borders surrounded by dark areas, reduce this value to make the borders clearer.	
002	Lower Limit	[0 to 100 / <b>57</b> / 1vol ]
	Defines the lower limit for grayscale. A smaller value allows a wider range of halftones at the dark end of the scale.	

2973*	Grayscale Cycle ( <b>SSP</b> )	[0 to 1000 / <b>100</b> / 10 sheets ]
	Sets the halftone operation interval in order to prevent deterioration of the OPC. If the number of copies exceeds this setting, at the end of the job, or if the door is opened and closed, charge correction is executed.	

2974*	Image Density	
001	Adjustment Mode	[1 to 5 / <b>3</b> / 1 ]
	Adjusts image density. Changing this setting adjusts development bias and ID sensor output voltage that in turn raises or lowers image density.	

2975*	Near End Setting	
	Detection Time	[0 to 2000 / 0 / 10 sec ]
	Sets a time for toner supply motor rotation for issuing the toner near end warning on the operation panel. The time may need to be shorter for customers who run especially large print jobs (working at night, for example) to ensure earlier warning of the toner near end condition so toner out does not interrupt a long job.	

2976*	Bottle Motor Time	
	Displays the total ON time of the toner supply motor, calculated from when the toner bottle was replaced. Use this to check that the toner end count (SP2975) is working properly. When SP2975 is set to any value other than "0", this value is displayed when it matches the setting of SP2975. When SP2975 is set to "0", SP2976 is disabled. SP2976 is automatically set to zero by toner end recovery.)	
	Time	[0 to 7,000,000 / 0 / 1 msec]

Appendix:  
Service  
Program  
Mode Tables

2977*	Toner End Status	
	Indicates the toner near end or end condition.	
001	Near End	<p>[0 to 10 / 0 / 1 ]</p> <p>0: Not detected</p> <p>1: Detected by SP2975-001</p> <p>2: <math>V_t(10) - V_{ref} &gt; 0.2</math> and <math>V_{sp} &gt; 0.6</math></p> <p>3: <math>V_t(10) - V_{ref} &gt; 0.45</math></p> <p>4: <math>0.45 &gt; V_t(10) - V_{ref} &gt; 0.2</math> and toner end counter <math>&gt; 300</math></p> <p>5 to 10: Not used</p>
002	End	<p>[0 to 10 / 0 / 1 ]</p> <p>0: Not detected</p> <p>1: <math>V_{sp} &gt; 2.0</math></p> <p>2: Toner end counter <math>&gt; 90</math> when SP2213-001 is set to "0".</p> <p>3: Toner end counter <math>&lt; 90</math> and <math>V_t(10) &gt; (V_{ref} + 0.3)</math> when SP2213-001 is set to "0".</p> <p>4: When SP2213-001 is set to "2"</p> <p>5: <math>V_{sp} &gt; 0.9</math> when SP2213-001 is set to "2"</p> <p>6: Special order</p> <p>7 to 10: Not used</p>

2980*	Charge Counter	[0 to 1000000 / 0 / 1 sheets ]
	<p>Set the number of pages to print after toner and carrier initialization before the charge input is increased to compensate for deterioration over time in the polarity of the carrier.</p> <p>The strength in the polarity of the carrier in the toner will eventually decrease and cause lower charge output. Setting the charge output to increase after a specified number of copies can compensate for this effect.</p>	



### 3.4 ENGINE SP TABLES-3

#### 3.4.1 SP3-XXX: PROCESS

3001	P Sensor Setting	
	Current	[0 to 43 / <b>13</b> / 0.1 mA]
001*	Allows you to reset the PWM of the ID sensor LED to avoid a service call error after clearing NVRAM or replacing the NVRAM. The PWM data is stored by executing SP-3001-2.	
	Initialization	-
002	Performs the ID sensor initial setting. ID sensor output for the bare drum (VSG) is adjusted automatically to 4.0 ±0.2 V. Press "Execute" to start. Perform this setting after replacing or cleaning the ID sensor, replacing the drum, or clearing NVRAM.	

3045*	Toner End Setting <b>DFU</b>	
001	ON/OFF	[0 to 1 / <b>0</b> / 1] 0=Off, 1=On

	P Sensor Output	
3103*	Displays the current VSG, VSP, VSDP, and grayscale control. If the P sensor does not detect the P pattern, "VSP = 5.0 V/VSG = 5.0 V" is displayed and an SC code is generated. If the P sensor does not detect the bare area of the drum, "VSP = 0.0 V/VSG =0.0 V" is displayed and an SC code is generated.	
001	Vsg	[0 to 5 / <b>0</b> / 0.01]
002	Vsp	[0 to 5 / <b>0</b> / 0.01]
003	Vsdp	[0 to 5 / <b>0</b> / 0.01]
004	Vsm/Vsg	[0 to 5 / <b>0</b> / 0.01]

Appendix:  
Service  
Program  
Mode Tables

3902*	New PCU Detection ( <b>Not used</b> )	
001	ON/OFF Setting	[0 to 1 / <b>0</b> / 1] 0: On, 1: Off
	Turns on or off the new unit detection for the transfer belt unit and fusing unit.	

3905*	Hot Roller Stripper Cleaning	
	"Cleaning A": 15 sec. off/on cycle for the fusing motor. "Cleaning B": Off (45 sec.) and On (15 sec.) cycle for the fusing motor.	
001	1st Cleaning: Interval	
	Sets the threshold for the 1st cleaning mode. "Cleaning A" is done once. [0 to 5 / <b>5</b> / 1 sheets]	
002	1st Cleaning: Mode Setting	
	Sets the number of additional execution times of the 1st cleaning mode. [0 to 5 / <b>0</b> / 1 times]	
003	2nd Cleaning: Interval	
	Sets the threshold for the 2nd cleaning mode. "Cleaning A" is done twice. [6 to 49 / <b>30</b> / 1 sheets]	
004	2nd Cleaning: Mode Setting	
	Sets the number of additional execution times of the 2nd cleaning mode. [0 to 5 / <b>0</b> / 1 times]	

005	3rd Cleaning: Interval
	<p>Sets the threshold for the 3rd cleaning mode.</p> <p>"Cleaning A" is done twice and "Cleaning B" is done "N" times.</p> <p>"N" is specified with SP3905-006.</p> <p>[50 to 999 / <b>100</b> / 1 sheets]</p>
006	3rd Cleaning: Mode Setting
	<p>Sets the number of execution times of the 3rd cleaning mode.</p> <p>[0 to 5 / <b>0</b> / 1 times]</p> <p> <b>Note</b></p> <ul style="list-style-type: none"> <li>▪ All fans remain on during cleaning and then switch off 60sec after the cleaning cycle ends.</li> </ul>
007	Cleaning Priority Setting
	<p>[0 to 1 / <b>0</b> / 1 sheets]</p> <p>0: Priority to printing (No job interruption)</p> <p>1: Priority to cleaning (Job interruption)</p>

## **3.5 ENGINE SP TABLES-4**

### **3.5.1 SP4-XXX: SCANNER**

There are no Group 4 SP modes for this machine.

### 3.6 ENGINE SP TABLES-5

#### 3.6.1 SP5-XXX: MODE

5009*	Add Disp. Lang	Bit SW
201,202,203,204	Adds language available in user choice. (Only the languages registered in the machine)	
	Refer to the displayed language list to set in the way showed below.	
	List Num.	Assigned Bit Switch
	No.1~8	BIT1 to 8 (SP5009-201)
	No.9~16	BIT1 to 8 (SP5009-202)
	No.17~24	BIT1 to 8 (SP5009-203)
	No.25~32	BIT1 to 8 (SP5009-204)
<p>Example: To add American(No.3 in the list) or Czech (No.15)</p> <p>Turn Bit 3 of "SP5009-201" 0 to 1 for American.</p> <p>Turn Bit 7 of "SP5009-202" 0 to 1 for Czech.</p> <p>After setting, turn the main power switch off and on to make the setting valid.</p>		

Appendix:  
Service  
Program  
Mode Tables

5024*	mm/inch Display Selection	0: Europe/Asia (mm) 1: North America (inch)
	<p>Selects the unit of measurement.</p> <p>After selection, turn the main power switch off and on.</p>	

5045*	Accounting counter
	<p>Selects whether the printer counter is displayed on the LCD.</p> <p>[0-1 / <b>0</b> / 1]</p> <p>0: Displays the total counter only.</p> <p>1: Displays both total counter and printer counter.</p>

5047*	Paper Display
	<p>Turns on or off the printed paper display on the LCD.</p> <p>[0 to 1 / <b>0</b> / 1]</p> <p>0: Not displayed, 1: Displayed</p>

5056*	Coverage Counter Display
	<p>Display or does not display the coverage counter on the LCD.</p> <p>[0 to 1 / <b>0</b> / 1]</p> <p>0: Not displayed, 1: Displayed</p>

5061*	Toner Remaining Icon Display Change
	<p>Display or does not display the remaining toner display icon on the LCD.</p> <p>[0 to 1 / <b>0</b> / 1]</p> <p>0: Not display, 1: Display</p>

5074*	Home Screen Login
	Sets the application that appears when the home key is pressed.
002	Setting
	<p>[0 to 11111111 / <b>0</b> / 1]</p> <p><b>0: OFF, 1: ON</b></p>
091	Home Key Customization
	<p>[0 to 2 / <b>0</b> / 1]</p> <p>0: OFF (Function disabled), 1: SDK, 2: Reserve (Legacy application)</p>

092	Product ID
	Sets the Application product ID. [0x00 to 0xffff / <b>0x00</b> / 1]
093	Application Screen ID
	Sets the display category of the application that is specified in SP5075-001. [0 to 255 / <b>0</b> / 1]

5075*	USB Keyboard
001	Function Setting
	[0 to 1 / <b>0</b> / 1] 0: Disabled, 1: Enabled

5083*	LED ON-OFF setting at Toner Near End
001	Turns LED yellow lighting ON and OFF at Toner Near End. [0 to 1 / <b>0</b> / 1] 0: OFF, 1: ON

5104*	A3/DLT Double Count ( <b>SSP</b> )
	Specifies whether the counter is doubled for A3/DLT. "Yes" counts except from the bypass tray. When "Yes" is selected, A3 and DLT paper are counted twice, that is A4 x2 and LT x2 respectively.

5112*	Non-Std. Paper Sel.
	Non-Standard Paper Selection [0 to 1 / <b>0</b> / 1] 0: Not use, 1: Use

Appendix:  
Service  
Program  
Mode Tables

5131*	Paper Size Type Selection	
	Selects the paper size (type) for both originals and copy paper. [0 to 2 / - / 1 step] 0: Japan, 1: North America, 2: Europe After changing the setting, turn the copier off and on. If the paper size of the archive files stored on the HDD is different, abnormal copies could result.	

5150	Bypass Length Setting	
	Sets up the by-pass tray for long paper. [0 to 1 / 0 / 1] 0: Off [Default] 1: On. Sets the tray for feeding paper up to 600 mm long. With this SP selected on, paper jams are not detected in the paper path.	

5166*	Lump Delete Form Setting	
021	Last Deleted Time	
	Displays the last delete time. [0 to 4294967295 / 0 / 1]	

5179*	By-pass Tray Paper Size Error	[0 to 1 / 0 / 1 ] 0= OFF, 1= ON
	This SP determines whether a paper size error prompt appears when the machine detects the wrong paper size for the job and during feed from the by-pass tray.	



5181*	Paper Size Setting	
	Adjusts the paper size for each tray. [0 to 1 / - / 1]	
001	Tray 1: 1	0: A4 LEF, 1: LT LEF
002	Tray 1: 2	0: A3, 1: DLT
003	Tray 1: 3	0: B4, 1: LG
004	Tray 1: 4	0: B5 LEF, 1: Exe LEF
005	Tray 2: 1	0: A4 LEF, 1: LT LEF
006	Tray 2: 2	0: A3, 1: DLT
007	Tray 2: 3	0: B4, 1: LG
008	Tray 2: 4	0: B5 LEF, 1: Exe LEF
009	Tray 3: 1 (Tandem)	0: A4 LEF, 1: LT LEF
010	Tray 3: 2	0: A3, 1: DLT
011	Tray 3: 3	0: B4, 1: LG
012	Tray 3: 4	0: B5 LEF, 1: Exe LEF
013	Tray 4: 1	0: A4 LEF, 1: LT LEF
014	Tray 4: 2	0: A3, 1: DLT
015	Tray 4: 3	0: B4, 1: LG
016	Tray 4: 4	0: B5 LEF, 1: Exe LEF
017	LCT	[0 to 2 / - / 1] 0: A4 LEF, 1: LT LEF, 2: B5 LEF

Appendix:  
Service  
Program  
Mode Tables

5186	RK4: Setting <b>(Japan only)</b>
	<p>Enable or distance the prevention for RK4 (Accounting device) Disconnection. If the RK4 is disconnected for 10 seconds when this SP is set to "1 (Enable)", the machine automatically jams a sheet of paper and stops.</p> <p>[0 to 1 / <b>0</b> / 1]</p>

5199	<p>Paper Exit After Staple End</p> <p>This SP determines whether the machine can output paper if staples run out.</p> <p>[0 to 1 / <b>0</b> / 1]</p> <p>0: OFF. Paper cannot exit if no staples are available. 1: ON. Paper can exit with no staples.</p>
------	---

5302*	Set Time
002	<p>Time Difference</p> <p>Sets the time clock for the local time. This setting is done at the factory before delivery. The setting is GMT expressed in minutes.</p> <p>[-1440 to 1440 / - / 1 min.]</p> <p>Japan: +540 (Tokyo) NA: -300 (NY) EU: +60 (Paris) CH: +480 (Peking) TW: +480 (Taipei) AS: +480 (Hong Kong) KO: +540 (Korea)</p>

5305	Blue Angel Compliance
⇒ 101	<p>Settings items and the range regarding sleep mode suitable for Blue Angel regulations.</p> <p>[0 to 1 / <b>0</b> / 1]</p>

5307	Summer Time	
001	Setting	[0 to 1 / 1 (NA/EU), 0 (ASIA) / 1 /step] 0: Disabled 1: Enabled
	<p>Enables or disables the summer time mode.</p> <p><b>Note</b></p> <ul style="list-style-type: none"> <li>Make sure that both SP5-307-3 and -4 are correctly set. Otherwise, this SP is not activated even if this SP is set to "1".</li> </ul>	
003	Rule Set (Start)	
	<p>Specifies the start setting for the summer time mode.</p> <p>There are 8 digits in this SP. For months 1 to 9, the "0" cannot be input in the first digit, so the eight-digit setting for -2 or -3 becomes a seven-digit setting.</p> <p>1st and 2nd digits: The month. [1 to 12] 3rd digit: The week of the month. [1 to 5] 4th digit: The day of the week. [0 to 6 = Sunday to Saturday] 5th and 6th digits: The hour. [00 to 23] 7th digit: The length of the advanced time. [0 to 9 / 1 hour /step] 8th digit: The length of the advanced time. [0 to 5 / 10 minutes /step]</p> <p>For example: 3500010</p> <p>The timer is advanced by 1 hour at am 0:00 on the 5th Sunday in March.</p> <p>The digits are counted from the left.</p> <p>Make sure that SP5-307-1 is set to "1".</p>	
004	Rule Set (End)	
	<p>Specifies the end setting for the summer time mode.</p> <p>There are 8 digits in this SP.</p> <p>1st and 2nd digits: The month. [1 to 12] 3rd digit: The week of the month. [0 to 5] 4th digit: The day of the week. [0 to 7 = Sunday to Saturday] 5th and 6th digits: The hour. [00 to 23]</p> <p>The 7th and 8 digits must be set to "00".</p> <p>The digits are counted from the left.</p> <p>Make sure that SP5-307-1 is set to "1".</p>	

5401	Access Control <b>(DFU)</b>	
	This SP stores the settings that limit uses access to SDK application data.	
103	Default Document ACL	<p>Whenever a new login user is added to the address book in external certification mode (for Windows, LDAP, RDH), the default document ACL is updated according to this SP setting.</p> <p>[0 to 3 / <b>0</b> / 1/step]</p> <p>0: View 1: Edit 2: Edit/Delete 3: Full control</p> <p>Note: This SP setting is ignored on a machine that is not using document server.</p>
104	Authentication Time	<p>Specifies the timeout of the authentication.</p> <p>[0 to 255 / <b>0</b> / 1 sec./step]</p> <p>0: 60 seconds 1 to 250 seconds</p>
162	Extend Certification Detail	<p>Selects the log out type for the extend authentication device.</p> <p>Bit 0: Log-out without an IC card</p> <p>0: Not allowed (default) 1: Allowed</p>
200	SDK1 Unique ID	<p>"SDK" is the "Software Development Kit". This data can be converted from SAS (VAS) when installed or uninstalled.</p> <p><b>(DFU)</b></p>
201	SDK1 Certification Method	
210	SDK2 Unique ID	
211	SDK2 Certification Method	
220	SDK3 Unique ID	
221	SDK3 Certification Method	

230	SDK certification device	
240	Detail Option	<p>Enables or disables the log out confirmation option.</p> <p>Bit 0: Log out confirmation option 0: Enable (default), 1: Disable</p> <p>Selects the automatic log out time.</p> <p>Bit 1 and 2: Automatic log out timer reduction</p> <p>00: 60 seconds (default), 01: 10 seconds, 10: 20 seconds, 11: 30 seconds</p>

5402	Access Control ( <b>DFU</b> )	
	Sets limited uses for SDKJ application data.	
101 to 130	SDKJ1 Limit Setting..... SDKJ30 Limit Setting	<p>[ / 0x00 / 0x01/step]</p> <p>bit0: SDKJ Authentication -0: Panel Type -1: Remote Type</p> <p>bit1: Using user code setup -0: OFF, 1: ON</p> <p>bit2: Using key-counter setup -0: OFF, 1: ON</p> <p>bit3: Using billing external device setup -0: OFF, 1: ON</p> <p>bit3: Using external billing device setup -0: OFF, 1: ON</p> <p>bit4: Using extended external billing device setup -0: OFF, 1: ON</p> <p>bit5~6: Not used</p> <p>bit7: Using extended function J limit users -0: OFF, 1: ON</p>
141 to 170	SDKJ1 Product ID..... SDKJ30 Product ID	[0 to 0xffffffff / 0 / 1/step]

Appendix:  
Service  
Program  
Mode Tables

5404	User Code Count Clear	
	Clears the counts of the user codes assigned by the key operator to restrict the use of the machine. Press [Execute] to clear.	

5411	LDAP-Certification	
004	Simplified Certification	Turns simple authentication on or off for LDAP. [0 or 1 / 1 / 1/step] 0: OFF 1: ON
005	Password Null Not Permit	This SP is enabled only when SP5411-4 is set to "1" (ON). [0 or 1 / 1 / 1/step] 0: Password null is permitted. 1: Password null is not permitted.
006	Detail Option	Determines whether LDAP option (anonymous certification) is turned on or off. [0 or 11111111 / 0 / 1/step] <b>0: OFF</b> , 1: ON

5412	Krb-Certification	
100	Encrypt Mode	Sets the level of Kerberos Certification. [0x01:AES256-CTS-HMAC-SHA1-96 / 0x02:AES128-CTS-HMAC-SHA1-96 / 0x04:DES3-CBC-SHA / 0x08:RC4-HMAC / 0x10:DES-CBC-MD5 / 0xFF:ALL / <b>0xFF</b> / 1bit]

5413	Lockout Setting	
001	Lockout On/Off	[0 or 1 / <b>0</b> / 1/step] 0: OFF, 1:ON
	Turns on or off the account lock for the local address book account.	
002	Lockout Threshold	[1 to 10 / <b>5</b> / 1/step]
	Sets the maximum trial times for accessing the address book account.	
003	Cancellation On/Off	[0 or 1 / <b>0</b> / 1/step] 0: OFF (Lockout is not cancelled.) 1: ON (Lockout is cancelled if a user ID and password are correctly entered after the lockout function has been executed and a specific time has passed.)
	Turns on or off the cancellation function of the account lockout.	
004	Cancellation Time	[1 to 9999 / <b>60</b> / 1 min]
	Sets the interval of the retry for accessing the local address book account after the lockout function has been executed. This setting is enabled only if SP5413-3 is set to "1" (ON).	

5414	Access Mitigation	
001	Mitigation ON/OFF	
	Permits or does not permit consecutive access to the machine with the same ID and password. [0 or 1 / <b>0</b> / 1/step] 0: OFF (Permitted) 1: ON (Not permitted)	
002	Mitigation Time	
	Sets the prohibiting time for consecutive access to the machine with the same ID and password. [0 to 60 / <b>15</b> / 1 min]	

5415	Password Attack	
001	Permissible Number	[0 to 100 / <b>30</b> / 1 times]
	Sets the threshold number of attempts to attack the system with random passwords to gain illegal access to the system.	
002	Detect Time	[1 to 10 / <b>5</b> / 1 sec]
	Sets a detection time to count a password attack.	

5416	Access Information	
001	Access User Max Num	[50 to 200 / <b>200</b> / 1/step ]
	Sets the number of users for the access exclusion and password attack detection function.	
002	Access Password Num	[50 to 200 / <b>200</b> / 1/step ]
	Sets the number of passwords for the access exclusion and password attack detection function.	
003	Monitor interval	[1 to 10 / <b>3</b> / 1 sec]
	Sets the interval of watching out for user information and passwords.	

5417	Access Attack	
001	Access Permissible number	[0 to 500 / <b>100</b> / 1/step]
	Sets a limit on access attempts to prevent password cracking.	
002	Access Detect Time	[10 to 30 / <b>10</b> / 1 sec]
	Sets a detection time to count password cracking.	
003	Productivity Fall Weight	[0 to 9 / <b>3</b> / 1 sec]
	Sets the wait time to slow down the speed of certification when an excessive number of access attempts have been detected.	
004	Attack Max Num	[50 to 200 / <b>200</b> / 1/step]



	Sets a limit on the number of requests received for certification in order to slow down the certification speed when an excessive number of access attempts have been detected.
--	---

5420	User Authentication	
	These settings should be done with the System Administrator.  <b>Note</b> <ul style="list-style-type: none"> <li>These functions are enabled only after the user access feature has been enabled.</li> </ul>	
041	Printer	[0 or 1/ <b>0</b> / 1/step] 0: ON. 1: OFF Determines whether certification is required before a user can use the printer application.
051	SDK1	[0 or 1/ <b>0</b> / 1/step] 0: ON. 1: OFF Determines whether certification is required before a user can use the SDK application.
061	SDK2	
071	SDK3	

5430	Auth Dialog Message Change	
001	Message Change On/Off	Turns on or off the displayed message change for the authentication. [0 or 1 / <b>0</b> / 1/step] 0: Off, 1: On
002	Message Text Download	Executes the message download for the authentication.
003	Message Text ID	Inputs message text for the authentication.

5481	Authentication Error Code	
	These SP codes determine how the authentication failures are displayed.	
001	System Log Disp	<p>[0 or 1 / <b>0</b> / 1/step]                      0: OFF [Default], 1: ON                      Determines whether an error code appears in the system log after a user authentication failure occurs.</p>
002	Panel Disp	<p>[0 or 1 / <b>1</b> / 1/step]                      0: OFF, 1: ON [Default]                      Determines whether an error code appears on the operation panel after a user authentication failure occurs.</p>

5501*	PM Alarm	
001	PM Alarm Level	
	<p>Sets the PM alarm level.                      [0 to 9999 / <b>0</b> / 1 k copies/step]                      0: No PM alarm</p>	
002	Original Count Alarm ( <b>DFU</b> )	
	<p>Selects whether the PM alarm for the number of scans is enabled or not.                      If this is "1", the PM alarm function is enabled.                      [<b>0</b> = No / 1 = Yes]</p>	

5504*	Jam Alarm	
	<p>Sets the alarm to sound for the specified jam level (document misfeeds are not included).                      [0 to 3 / <b>3</b> / 1 step]                      0: Zero (Off)                      1: Low (2.5K jams)                      2: Medium (3K jams)                      3: High (6K jams)</p>	

5505*	Error Alarm
	<p>Sets the number of sheets to clear the error alarm counter.</p> <p>The error alarm counter counts "1" when any SC is detected. However, the error alarm counter decreases by "1" when an SC is not detected during a set number of copied sheets (for example, default 5000 (C1b) or 10000 (C1c) sheets). The error alarm occurs when the SC error alarm counter reaches "5".</p> <p>[0 to 255 / <b>60</b> / 100 copies / step]</p>

5507*	Supply Alarm	
001	Paper supply Alarm (0:Off 1:On)	<p>Switches the control call on/off for the paper supply. <b>(DFU)</b></p> <p><b>0: Off, 1: On</b></p> <p>0: No alarm.</p> <p>1: Sets the alarm to sound for the specified number transfer sheets for each paper size (A3, A4, B4, B5, DLT, LG, LT, HLT)</p>
002	Staple Supply Alarm (0:Off 1:On)	<p>Switches the control call on/off for the stapler installed in the finisher. <b>(DFU)</b></p> <p><b>0: Off, 1: On</b></p> <p>0: No alarm</p> <p>1: Alarm goes off for every 1K of staples used.</p>
003	Toner Supply Alarm (0:Off 1:On)	<p>Switches the control call on/off for the toner end. <b>(DFU)</b></p> <p><b>0: Off, 1: On</b></p> <p>If you select "1" the alarm will sound when the copier detects toner end.</p>
006	Waste Toner Bottle Alarm	<b>0: Off, 1: On</b>

Appendix:  
Service  
Program  
Mode Tables

Engine SP Tables-5

080	Toner Call Timing	Changes the timing of the "Toner Supply Call" via the @Remote, when the following conditions occur. <b>0:</b> At replacement <b>1:</b> At near end
128	Interval: Others	The "Paper Supply Call Level: nn" SPs specify the paper control call interval for the referenced paper sizes. <b>(DFU)</b> [250 to 10000 / <b>1000</b> / 1 Step]
132	Interval: A3	
134	Interval: A5	
141	Interval: B4	
142	Interval: B5	
160	Interval: DLT	
164	Interval: LG	
166	Interval: LT	
172	Interval: HLT	

5508	CC Call	
001	Jam Remains	Enables/disables initiating a call.
002	Continuous Jams	[0 to 1 / <b>1</b> / 1] <b>0:</b> Disable
003	Continuous Door Open	<b>1:</b> Enable
011	Jam Detection: Time Length	Sets the length of time to determine the length of an unattended paper jam. [3 to 30 / <b>10</b> / 1 minute]
012	Jam Detection Continuous Count	Sets the number of continuous paper jams required to initiate a call. [2 to 10 / <b>5</b> / 1 time]
013	Door Open: Time Length	Sets the length of time the remains opens to determine when to initiate a call. [3 to 30/ <b>10</b> / 1 minute]

5515*	SC/Alarm Setting	
	With @Remote in use, these SP codes can be set to issue an SC call when an SC error occurs. If this SP is switched off, the SC call is not issued when an SC error occurs.	
001	SC Call	[0 or 1 / 1 / 1] 0: OFF 1: ON
002	Service Parts Near End Call	
003	Service Parts End Call	
004	User Call	
006	Communication Information Test Call	
007	Machine Information Notice	
008	Alarm Notice	
009	Non-genuine Toner Alarm	
010	Supply Automatic Ordering Call	
011	Supply Management Report Call	
012	Jam/Door Open Call	

5516	Individual PM Part Alarm Call	
	With @Remote in use, these SP codes can be set to issue an PM alarm call when one of SP parts reaches its yield.	
001	Disable/Enable Setting (0: Not send, 1: Send)	[0 or 1 / 1 / -] 0: Not send, 1: Send
004	Percent yield for triggering PM alert	[1 to 255 / 75 / 1 %/step]

5730	Extend Function Setting	
	Expiration Prior Alarm Set	[0 to 999 / <b>20</b> / 1/step]

5731	[Counter Effect]	
	Charge MK1 Cnt (Paper >Combine)	[0 or 1 / <b>0</b> / 1/step]

5745	EcoCountTime	
	-	[0 to 1439 / <b>0</b> / -/step]

5746	BMLinkS (Japan only)	
001	available	Displays or enables the BMLinkS feature. [0 or 1 / <b>1</b> / -/step]
002	interval:mon	Displays the polling interval when the BMLinsS monitor service monitors the machine status. [10 to 3600 / <b>60</b> / 1 sec./step]
004	Available:log	Displays the sending feature status of the BMLinkS log service. [0 or 1 / <b>1</b> / -/step ] 0:Disable, 1: Enable



5749	Import/Export (Refer to Section 3.14 Import/Export for more information)	
1	Export	
101	Import	
251	Export Result Print (SP)	
252	Import Result Print (SP)	

5750	Job Access Log			
	Changes the capacity of log storage.			
	<b>SP7-750-001</b>	<b>Job Log</b>	<b>Access Log</b>	<b>Eco Log</b>
	0:OFF (Default)	2000	6000	2000
	1:ON	8000	1000	1000

5801	Memory Clear	
	Resets NVRAM data to the default settings. Before executing any of these SP codes, print an SMC Report.	
001	All Clear	Initializes items 2 to 19 below.
002	Engine	Initializes all registration settings for the engine and copy process settings.
003	SCS	Initializes default system settings, SCS (System Control Service) settings, operation display coordinates, and ROM update information.
008	Printer Application	Initializes the printer defaults, programs registered, the printer SP bit switches, and the printer CSS counter.
010	Web Service	Deletes the Netfile (NFA) management files and thumbnails, and initializes the Job login ID. Netfiles: Jobs to be printed from the document server using a PC and the DeskTopBinder software
011	NCS	Initializes the system defaults and interface settings (IP addresses also), the SmartDeviceMonitor for Admin settings, WebStatusMonitor settings, and the TELNET settings. (NCS: Network Control Service)

Appendix:  
Service  
Program  
Mode Tables

014	Clear DCS Setting	Initializes the DCS (Delivery Control Service) settings.
015	Clear UCS Setting	Initializes the UCS (User Information Control Service) settings.
016	MIRS Setting	Initializes the MIRS (Machine Information Report Service) settings.
018	SRM Memory Clr	Initializes the SRM (System Resource Manager) settings.
019	LCS	Initializes the LCS (Log Count Service) settings.

5802*	FreeRun	
	<p>Performs a free run on the copier engine.</p> <p>The correct paper should be loaded in the 1st tray or 2nd tray, but paper is not fed.</p> <p>The main switch has to be turned off and on after using the free run mode for a test.</p>	
001	TRAY1:A4LEF	-
002	TRAY2:A3	-
003	TRAY2:A4SEF	-

5803	Input Check	
	Displays the signals received from sensors and switches. (p.3-165)	

5804	Output Check	
	Turns on the electrical components individually for test purposes. (p.3-176)	



5805	Anti-Condensation Heater	
	[0 or 1 / 0 / -] 0:OFF / 1:ON	

5810	SC Reset	
001	Fusing SC Reset	Resets all level A service call conditions, such as fusing errors. To clear the service call, touch "Execute" on the LCD, then turn the main power switch off/on.

5811	MachineSerial	
002	Display	Displays the machine serial number.
004	BCU	Inputs the serial number.

5812*	Service Tel. No. Setting	
001	Service	Inputs the telephone number of the CE (displayed when a service call condition occurs.)
002	Facsimile	Use this to input the fax number of the CE printed on the Counter Report (UP mode).
003	Supply	Inputs the telephone number of the supplier displayed on the user mode screen.
004	Operation	Allows the service center contact telephone number to be displayed on the user mode screen.
101	Displnquiry	Allows the inquiry display to be displayed on the user mode screen. 0: Displayed 1: Not displayed

Appendix:  
Service  
Program  
Mode Tables

5816	Remote Service
	I/F Setting
001	<p>Selects the remote service setting.</p> <p>[0 to 2 / <b>2</b> / 1 /step]</p> <p>0: Remote service off</p> <p>1: CSS remote service on</p> <p>2: @Remote service on</p>
	CE Call
002	<p>Performs the CE Call at the start or end of the service.</p> <p>[0 or 1 / <b>1</b> / 1 /step]</p> <p>0: Start of the service</p> <p>1: End of the service</p> <p><b>NOTE:</b> This SP is activated only when SP 5816-001 is set to "2".</p>
	Function Flag
003	<p>Enables or disables the remote service function.</p> <p>[0 to 1 / <b>0</b> / 1 /step]</p> <p>0: Disabled, 1: Enabled</p> <p><b>NOTE:</b> This SP setting is changed to "1" after @Remote registration has been completed.</p>
	SSL Disable
007	<p>Uses or does not use the RCG certification by SSL when calling the RCG.</p> <p>[0 to 1 / <b>0</b> / 1 /step]</p> <p>0: Uses the RCG certification</p> <p>1: Does no use the RCG certification</p>
	RCG Connect Timeout
008	<p>Specifies the connect timeout interval when calling the RCG.</p> <p>[1 to 90 / <b>30</b> / 1 second /step]</p>

009	RCG Write Timeout
	Specifies the write timeout interval when calling the RCG. [0 to 100 / <b>60</b> / 1 second /step]
010	RCG Read Timeout
	Specifies the read timeout interval when calling the RCG. [0 to 100 / <b>60</b> / 1 second /step]
011	Port 80 Enable
	Enables/disables access via port 80 to the SOAP method. [0 or 1 / <b>0</b> / – ] 0: Disabled, 1: Enabled
013	RFU (Remote Firmware Update) Timing
	Selects the RFU timing. [0 or 1 / <b>1</b> / – ] 0: RFU is executed whenever update request is received. 1: RFU is executed only when the machine is in the sleep mode.
014	RCG Error Cause
	[0 or 1 / <b>0</b> / – ] 0: Normal 1: Fails to reflect the client/server certificate settings by network failure to reboot. Transitions to 0 on restarting the machine.
021	RCG–C Registered
	This SP displays the Embedded RC Gate installation end flag. 0: Installation not completed 1: Installation completed
023	Connect Type (N/M)
	This SP displays and selects the Embedded RC Gate connection method. [0 or 1 / <b>0</b> / 1 /step 0: Internet connection 1: Dial-up connection

Appendix:  
Service  
Program  
Mode Tables

061	Cert. Expire Timing <b>DFU</b>
	Proximity of the expiration of the certification.
062	Use Proxy
	This SP setting determines if the proxy server is used when the machine communicates with the service center.
063	Proxy Host
	<p>This SP sets the address of the proxy server used for communication between Embedded RC Gate-N and the gateway. Use this SP to set up or display the customer proxy server address. The address is necessary to set up Embedded RC Gate-N.</p> <p><b>Note</b></p> <ul style="list-style-type: none"> <li>▪ The address display is limited to 128 characters. Characters beyond the 128 character are ignored.</li> <li>▪ This address is customer information and is not printed in the SMC report.</li> </ul>
064	Proxy Port Number
	<p>This SP sets the port number of the proxy server used for communication between Embedded RC Gate-N and the gateway. This setting is necessary to set up Embedded RC Gate-N.</p> <p><b>Note</b></p> <ul style="list-style-type: none"> <li>▪ This port number is customer information and is not printed in the SMC report.</li> </ul>
065	Proxy User Name
	<p>This SP sets the HTTP proxy certification user name.</p> <p><b>Note</b></p> <ul style="list-style-type: none"> <li>▪ The length of the name is limited to 31 characters. Any character beyond the 31st character is ignored.</li> <li>▪ This name is customer information and is not printed in the SMC report.</li> </ul>

066	Proxy Password	
	<p>This SP sets the HTTP proxy certification password.</p> <p><b>Note</b></p> <ul style="list-style-type: none"> <li>▪ The length of the password is limited to 31 characters. Any character beyond the 31st character is ignored.</li> <li>▪ This name is customer information and is not printed in the SMC report.</li> </ul>	
067	CERT: Up State	
	Displays the status of the certification update.	
	0	The certification used by Embedded RC Gate is set correctly.
	1	The certification request (setAuthKey) for update has been received from the GW URL and certification is presently being updated.
	2	The certification update is completed and the GW URL is being notified of the successful update.
	3	The certification update failed, and the GW URL is being notified of the failed update.
	4	The period of the certification has expired and new request for an update is being sent to the GW URL.
	11	A rescue update for certification has been issued and a rescue certification setting is in progress for the rescue GW connection.
	12	The rescue certification setting is completed and the GW URL is being notified of the certification update request.
	13	The notification of the request for certification update has completed successfully, and the system is waiting for the certification update request from the rescue GW URL.
	14	The notification of the certification request has been received from the rescue GW controller, and the certification is being stored.
15	The certification has been stored, and the GW URL is being notified of the successful completion of this event.	

Appendix:  
Service  
Program  
Mode Tables

	16	The storing of the certification has failed, and the GW URL is being notified of the failure of this event.
	17	The certification update request has been received from the GW URL, the GW URL was notified of the results of the update after it was completed, but a certification error has been received, and the rescue certification is being recorded.
	18	The rescue certification of No. 17 has been recorded, and the GW URL is being notified of the failure of the certification update.
068	CERT: Error	
	Displays a number code that describes the reason for the request for update of the certification.	
	0	Normal. There is no request for certification update in progress.
	1	Request for certification update in progress. The current certification has expired.
	2	An SSL error notification has been issued. Issued after the certification has expired.
	3	Notification of shift from a common authentication to an individual certification.
	4	Notification of a common certification without ID2.
	5	Notification that no certification was issued.
6	Notification that GW URL does not exist.	
069	CERT: Up ID	The ID of the request for certification.
083	Firm Up Status	Displays the status of the firmware update.
085	Firm Up User Check	This SP setting determines if the operator can confirm the previous version of the firmware before the firmware update execution. If the option to confirm the previous version is selected, a notification is sent to the system manager and the firmware update is done with the firmware files from the URL.

086	Firmware Size	Allows the service technician to confirm the size of the firmware data files during the firmware update execution.
087	CERT: Macro Ver.	Displays the macro version of the @Remote certification.
088	CERT: PAC Ver.	Displays the PAC version of the @Remote certification.
089	CERT: ID2 Code	Displays ID2 for the @Remote certification. Spaces are displayed as underscores (_). Asterisks (*) indicate that no @Remote certification exists. "000000_____" indicates "Common certification".
090	CERT: Subject	Displays the common name of the @Remote certification subject. CN = the following 17 bytes. Spaces are displayed as underscores (_). Asterisks (*) indicate that no @Remote certification exists. "000000_____" indicates "Common certification".
091	CERT: SerialNo.	Displays serial number for the @Remote certification. Asterisks (*) indicate that no @Remote certification exists.
092	CERT: Issuer	Displays the common name of the issuer of the @Remote certification. CN = the following 30 bytes. Asterisks ( ) indicate that no @Remote certification exists.
093	CERT: Valid Start	Displays the start time of the period for which the current @Remote certification is enabled.
094	CERT: Valid End	Displays the end time of the period for which the current @Remote certification is enabled.
095	Server CN Check	
	<b>Not used</b>	

096	GW Host	
	<b>Not used</b>	
097	GW URL Path	
	<b>Not used</b>	
099	Debug RescueG/WURL Set	
	<b>Not used</b>	
102*	CERT: Encrypt Level	
	<p>Displays the encryption level for the NRS certificate.</p> <p>[1 or 2 / 1 / – ]</p> <p>1: Indicates that the certificate encryption level is 512-bit.</p> <p>2: Indicates that the certificate encryption level is 2048-bit.</p>	
200	Manual Polling	
	Executes the manual polling.	
201	Regist Status	
	<p>Displays a number that indicates the status of the @Remote service device.</p> <p>0: Neither the @Remote device nor Embedded RCG Gate is set.</p> <p>1: The Embedded RCG Gate is being set. Only Box registration is completed. In this status, @Remote device cannot communicate with this device.</p> <p>2: The Embedded RCG Gate is set. In this status, the @Remote device cannot communicate with this device.</p> <p>3: The @Remote device is being set. In this status the Embedded RCG Gate cannot be set.</p> <p>4: The @Remote module has not started.</p>	
202	Letter Number	Allows entry of the request number needed for the Embedded RCG Gate.
203	Confirm Execute	Executes the confirmation request to the @Remote Gateway.



204	Confirm Result	
	<p>Displays a number that indicates the result of the confirmation executed with SP5816-203.</p> <p>0: Succeeded                      1: Confirmation number error                      2: Registration in progress                      3: Proxy error (proxy enabled)                      4: Proxy error (proxy disabled)                      5: Proxy error (Illegal user name or password)                      6: Communication error                      7: Certification update error                      8: Other error                      9: Confirmation executing</p>	
	Confirm Place	
205	<p>Displays the result of the notification sent to the device from the Gateway in answer to the confirmation request. Displayed only when the result is registered at the Gateway.</p>	
206	Register Execute	Executes "Embedded RCG Registration".
	Register Result	
207	<p>Displays a number that indicates the registration result.</p> <p>0: Succeeded                      2: Registration in progress                      3: Proxy error (proxy enabled)                      4: Proxy error (proxy disabled)                      5: Proxy error (Illegal user name or password)                      6: Communication error                      7: Certification update error                      8: Other error                      9: Registration executing</p>	

Appendix:  
 Service  
 Program  
 Mode Tables

208	Error Code		
	Displays a number that describes the error code that was issued when either SP5816-204 or SP5816-207 was executed.		
	<b>Cause</b>	<b>Code</b>	<b>Meaning</b>
	Illegal Modem Parameter	-11001	Chat parameter error
		-11002	Chat execution error
		-11003	Unexpected error
	Operation Error, Incorrect Setting	-12002	Inquiry, registration attempted without acquiring device status.
		-12003	Attempted registration without execution of an inquiry and no previous registration.
		-12004	Attempted setting with illegal entries for certification and ID2.
		-12005	@Remote communication is prohibited. The device has an Embedded RC gate-related problem.
		-12006	A confirmation request was made after the confirmation had been already completed.
		-12007	The request number used at registration was different from the one used at confirmation.
		-12008	Update certification failed because mainframe was in use.
		-12009	ID2 mismatch between an individual certification and NVRAM
	-12010	Certification area is not initialized.	

	Error Caused by Response from GW URL	-2385	Attempted dial up overseas without the correct international prefix for the telephone number.
		-2387	Not supported at the Service Center
		-2389	Database out of service
		-2390	Program out of service
		-2391	Two registrations for same device
		-2392	Parameter error
		-2393	RCG device not managed
		-2394	Device not managed
		-2395	Box ID for RCG device is illegal
		-2396	Device ID for RCG device is illegal
		-2397	Incorrect ID2 format
		-2398	Incorrect request number format
209	Instl Clear	Releases the machine from its Embedded RCG Gate setup. <b>NOTE:</b> Turn off and on the main power switch after this setting has been changed.	
250	CommLog Print	Prints the communication log.	

Appendix:  
Service  
Program  
Mode Tables

5821*	Remote Service Address	
002	RCG IP Address	Sets the IP address of the RCG (Remote Communication Gate) destination for call processing at the remote service center. [00000000h to FFFFFFFFh / <b>00000000h</b> / 1]
003	RCG Port	Sets the port number of the RCG (Remote Communication Gate) destination for call processing at the remote service center. [0 to 65535 / <b>443</b> / 1]
004	RCG URL Path	Sets the URL path of the RCG (Remote Communication Gate) destination for call processing at the remote service center. [0 to 16 characters / <b>/RCG/services/</b> /-]

5824	NV-RAM Data Upload	
	Uploads the NVRAM data to an SD card. Push Execute. <b>Note:</b> When uploading data in this SP mode, the front door must be open.	

5825	NV-RAM Data Download	
	Downloads data from an SD card to the NVRAM in the machine. After downloading is completed, remove the card and turn the machine power off and on.	

5828	Network Setting		
001	IPv4 Address (Ethernet/IEEE 802.11)		
	This SP allows you to check and reset the IPv4 address for Ethernet and wireless LAN (802.11): aaa.bbb.ccc.ddd		
050	1284 Compatibility (Centro)	Enables and disables bi-directional communication on the parallel connection between the machine and a computer. [0 to 1 / 1 / 1] 0:Off, 1: On	
052	ECP (Centro)	Disables and enables the ECP feature (1284 Mode) for data transfer. [0 to 1 / 1 / 1] 0: Disabled, 1: Enabled	
065	Job Spooling	Switches the job spooling on and off. [0 to 1 / 0 / 1] 0: No spooling, 1: Spooling enabled	
066	Job Spooling Clear: Start Time	This SP determines whether the job interrupted at power off is resumed at the next power on. This SP operates only when SP5828-065 is set to "1". [0 to 1 / 1 / 1] 1: OFF Resumes printing spooled jog. 0: ON Clears spooled job.	
069	Job Spooling (Protocol)	This SP determines whether job spooling is enabled or disabled for each protocol. This is a 8-bit setting. [0 to 1 / 1 / 1] 0: No spooling, 1: Spooling enabled	
	0	LPR	4 BMLinks (Japan Only)
	1	FTP (Not Used)	5 DIPRINT
	2	IPP	6 SFTP

Appendix:  
Service  
Program  
Mode Tables

	3	SMB	7	WSPRND
084	Delete Password			
	Executes NCS related parameter list printing			
087	@Remote Protocol Cnt ( <b>DFU</b> )			
090	TELNET (0:OFF 1:ON)	Disables or enables Telnet operation. If this SP is disabled, the Telnet port is closed. [0 to 1 / 1 / 1] 0: Disable, 1: Enable		
091	Web (0:OFF 1:ON)	Disables or enables the Web operation. [0 to 1 / 1 / 1] 0: Disable, 1: Enable		
145	Active IPv6 Link Local Address	This is the IPv6 local address referenced on the Ethernet or wireless LAN (802.11) in the format: "Link-Local address" + "Prefix Length" The IPv6 address consists of a total 128 bits configured in 8 blocks of 16 bits each. These notations can be abbreviated. See "Note: IPV6 Addresses " below this table.		
147	Active IPv6 Stateless Address 1	These SPs are the IPv6 stateless addresses (1 to 5) referenced on the Ethernet or wireless LAN (802.11) in the format: "Stateless Address" + "Prefix Length" The IPv6 address consists of a total 128 bits configured in 8 blocks of 16 bits each.		
149	Active IPv6 Stateless Address 2			
151	Active IPv6 Stateless Address 3			
153	Active IPv6 Stateless Address 4			

155	Active IPv6 Stateless Address 5	
156	IPv6 Manual Address	
	<p>This SP is the IPv6 manually set address referenced on the Ethernet or wireless LAN (802.11) in the format:                  "Manual Set Address" + "Prefix Length"                  The IPv6 address consists of a total 128 bits configured in 8 blocks of 16 bits each. These notations can be abbreviated. See "Note: IPV6 Addresses" below this table.</p>	
158	IPv6 Gateway Address	
	<p>This SP is the IPv6 gateway address referenced on the Ethernet or wireless LAN (802.11). The IPv6 address consists of a total 128 bits configured in 8 blocks of 16 bits each. These notations can be abbreviated. See "Note: IPV6 Addresses" below this table.</p>	
<p><b>Note: IPV6 Addresses</b>                  Ethernet and the Wireless LAN (802.11) reference the IPV6 "Link-Local address + Prefix Length". The IPV6 address consists of 128 bits divided into 8 blocks of 16 bits:                  aaaa:bbbb:cccc:dddd:eeee:ffff:gggg:hhhh:                  The prefix length is inserted at the 17th byte (Prefix Range: 0x0 to 0x80). The initial setting is 0x40 (64).                  For example, the data: "2001123456789012abcdef012345678940h" is expressed:                  "2001:1234:5678:9012:abcd:ef01:2345:6789": prefixlen 64                  However, the actual IPV6 address display is abbreviated according to the following rules.</p>		

**Rules for Abbreviating IPV6 Addresses**

1. The IPV6 address is expressed in hexadecimal delimited by colons (:) with the following characters:  
0123456789abcdefABCDEF
2. A colon is inserted as a delimiter every 4th hexadecimal character.  
fe80:0000:0000:0000:0207:40ff:0000:340e
3. The notations can be abbreviated by eliminating zeros where the MSB and digits following the MSB are zero. The example in "2" above, then, becomes  
fe80:0:0:0207:40ff:0:340e
4. Sections where only zeros exist can be abbreviated with double colons (::). This abbreviation can be done also where succeeding sections contain only zeros (but this can be done only at one point in the address). The example in "2" and "3" above then becomes:  
fe80::207:40ff:0:340e (only the first null sets zero digits are abbreviated as "::")  
-or-  
fe80:0:0:0:207:40ff::340e (only the last null set before "340e" is abbreviated as "::")

161	IPv6 Stateless Auto Setting	Enable or disables the automatic setting for IPv6 stateless. [0 or 1 / 1 / 1] 1: Enable, 0: Disable
236	<p>Web Item visible</p> <hr/> <p>Displays or does not display the Web system items. [0 x 0000 to 0 x ffff / 0 x ffff] 0: Not displayed, 1: Displayed bit0: Net RICOH bit1: Consumable Supplier bit2-15: Reserved (all)</p>	
237	<p>Web shopping link visible</p> <hr/> <p>Displays or does not display the link to Net RICOH on the top page and link page of the web system. [0 to 1 / 1 / 1] 0: Not display, 1:Display</p>	



238	Web supplies Link visible	
	Displays or does not display the link to Consumable Supplier on the top page and link page of the web system. [0 to 1 / 1 / 1] 0: Not display, 1:Display	
239	Web Link1 Name	
	This SP confirms or changes the URL1 name on the link page of the web system. The maximum characters for the URL name are 31 characters.	
240	Web Link1 URL	
	his SP confirms or changes the link to URL1 on the link page of the web system. The maximum characters for the URL are 127 characters.	
241	Web Link1 visible	
	Displays or does not display the link to URL1 on the top page of the web system. [0 to 1 / 1 / 1] 0: Not display, 1:Display	
242	Web Link2 Name	Same as "-239"
243	Web Link2 URL	Same as "-240"
244	Web Link2 visible	Same as "-241"
249	DHCPv6 DUID	
	Sets DHCPv6 DUID. [00000000000000000000000000000000h to FFFFFFFFFFFFFFFFFFFFFFFFFFFFFFFFh / <b>00000000000000000000000000000000h / -]</b>	
251	UUID	
	<b>DFU</b>	

Appendix:  
Service  
Program  
Mode Tables

252	Compatible ID
	[0 to 1 / 1 / 1/step] 0= Disabled , 1= Enabled

5832	HDD
	Enter the SP number for the partition to initialize, then press #. When the execution ends, cycle the machine off and on.
001	HDD Formatting (All)
002	HDD Formatting (IMH)
003	HDD Formatting (Thumbnail)
004	HDD Formatting (Job Log)
005	HDD Formatting (Printer Fonts)
006	HDD Formatting (User Info)
007	Mail RX Data
008	Mail TX Data
009	HDD Formatting (Data for Design)
010	HDD Formatting (Log)
011	HDD Formatting (Ridoc I/F) (for Ridoc Desk Top Binder)

5834	Operation Panel Image Exposure Function
	<b>DFU</b>

5840*	IEEE 802.11	
006	Channel MAX	
	Sets the maximum range of the bandwidth for the wireless LAN. This bandwidth setting varies for different countries. [1 to 14 / <b>11 (NA), 13 (EU), 14 (JPN)</b> / 1] JPN: 1 to 14, NA: 1 to 11, EU: 1 to 13	
007	Channel MIN	
	Sets the minimum range of the bandwidth for operation of the wireless LAN. This bandwidth setting varies for different countries. [1 to 14 / <b>1</b> / 1] JPN: 1 to 14, NA: 1 to 11, EU: 1 to 13	
008	Transmission speed	[0 x 00 to 0 x FF / <b>0 x FF to Auto</b> / -]
	<b>0 x FF to Auto</b> [Default] 0 x 11 - 55M Fix 0 x 10 - 48M Fix 0 x 0F - 36M Fix 0 x 0E - 18M Fix 0 x 0D - 12M Fix 0 x 0B - 9M Fix 0 x 0A - 6M Fix	0 x 07 - 11M Fix 0 x 05 - 5.5M Fix 0 x 08 - 1M Fix 0 x 13 - 0 x FE (reserved) 0 x 12 - 72M (reserved) 0 x 09 - 22M (reserved)
011	WEP Key Select	
	Selects the WEP key. Bit 1 and 0 <b>00: Key1</b> , 01: Key2 (Reserved), 10: Key3 (Reserved), 11: Key4(Reserved) This SP is displayed only when the IEEE802.11 card is installed.	
013	RTS/CTS Thresh	
	Adjusts the RTS/CTS threshold for the IEEE802.11 card. [0 to 3000 / <b>2432</b> / 1] This SP is displayed only when the IEEE802.11 card is installed.	

	Fragment Thresh	
042	Adjusts the fragment threshold for the IEEE802.11 card. [256 to 2346 / <b>2346</b> / 1] This SP is displayed only when the IEEE802.11 card is installed.	
	11g CTS to Self	
043	Determines whether the CTS self function is turned on or off. [0 to 1 / <b>1</b> / 1] 0: Off, 1: On This SP is displayed only when the IEEE802.11 card is installed.	
	11g Slot Time	
044	Selects the slot time for IEEE802.11. [0 to 1 / <b>0</b> / 1] 0: 20 μm, 1: 9 μm This SP is displayed only when the IEEE802.11 card is installed.	
	WPA Debug Lvl	
045	Selects the debug level for WPA authentication application. [1 to 3 / <b>3</b> / 1] 1: Info, 2: warning, 3: error This SP is displayed only when the IEEE802.11 card is installed.	

	Supply Name Setting	
5841*	Press the User Tools key. These names appear when the user presses the Inquiry button on the User Tools screen.	
001	Toner Name Setting: Black	
007	OrgStamp	
011	StapleStd1	
012	StapleStd2	
013	StapleStd3	
014	StapleStd4	
021	StapleBind1	
022	StapleBind2	

023	StapleBind3	
-----	-------------	--

5842*	GWWS Analysis (DFU)		
	This is a debugging tool. It sets the debugging output mode of each Net File process. Bit SW 0011 1111	<b>Bit</b>	<b>Groups</b>
		0	System & other groups (LSB)
		1	Capture related
		2	Certification related
		3	Address book related
		4	Machine management related
		5	Output related (printing, delivery)
	6	Repository related	
001	Setting 1	Default: 00000000 – do not change Netfiles: Jobs to be printed from the document server using a PC and the DeskTopBinder software	
002	Setting 2	Adjusts the debug program mode setting. Bit7: 5682 mmseg-log setting 0: Date/Hour/Minute/Second 1: Minute/Second/Msec. 0 to 6: Not used	

Appendix:  
Service  
Program  
Mode Tables

5844	USB	
001	Transfer Rate	
	Sets the speed for USB data transmission. [0 x 01 or 0 x 04 / <b>0 x 04</b> /-] 0 x 01 [Full Speed], 0 x 04 [Auto Change]	
002	Vendor ID	

	<p>Sets the vendor ID: Initial Setting: 0x05A Ricoh Company [0x0000 to 0xFFFF/1] <b>(DFU)</b></p>
003	<p>Product ID</p> <p>Sets the product ID. [0x0000 to 0xFFFF/1] <b>(DFU)</b></p>
004	<p>Device Release No.</p> <p>Sets the device release number of the BCD (binary coded decimal) display. [0000 to 9999 / <b>100</b> / 1] <b>(DFU)</b> Enter as a decimal number. NCS converts the number to hexadecimal number recognized as the BCD.</p>
005	Fixed USB Port
	<p>This SP standardizes for common use the model name and serial number for USB PnP (Plug &amp; Play). It determines whether the driver requires re-installation. [0 to 2 / <b>0</b> / 1] 0: OFF 1: Level 1 2: Level 2</p>
006	PnP Model Name
	<p>This SP sets the model name to be used by the USB PnP when "Function Enable (Level 2) is set so the USB Serial No. can have a common name (SP5844-5). Default: <b>Laser Printer</b> (up to 20 characters allowed).</p>

007	PnP Serial Number
	<p>This SP sets the serial number to be used by the USB PnP when "Function Enable (Level 2) set so the USB Serial No. can have a common name (SP5844-5). Default: None (up to 12 characters allowed for entry).</p> <ul style="list-style-type: none"> <li>▪ Make sure that this entry is the same as the serial number in use.</li> <li>▪ At initialization the serial number generated from the model name is used, not the setting of this SP code.</li> <li>▪ At times other than initialization, the value set for this SP code is used.</li> </ul>
100	Notify Unsupport
	<p>This SP determines whether an alert message appears on the control panel when a USB device (unsupported device) that cannot use an A-connector is connected. [0 to 1 / 1 / 1] 0: Function enable 1: Function disable</p> <ul style="list-style-type: none"> <li>▪ An unsupported device is a device that cannot use the functions of the USB device. For example, a USB mouse cannot be used even if it connected.</li> <li>▪ If the PictBridge option is not mounted, even if a digital camera is connected it cannot be used because it is an unsupported device.</li> </ul>

5845*	Delivery Server Setting	
	These are delivery server settings.	
003	Delivery Retry Interval	
	[60 to 900 / <b>300</b> / 1 /step] Sets the wait time from the error action to the retry.	
004	Delivery Retry times	
	[0 to 99 / <b>3</b> / 1time(s) /step] Sets how many times to retry.	
022	Rapid Sending Control	[0 to 1 / <b>1</b> / -] 0: Disable, 1: Enable
	Enables or disables the prevention function for the continuous data sending error.	



5846*	UCS Setting	
010	LDAP Search Timeout	
	Sets the length of the time-out for the search of the LDAP server. [1 to 255 / <b>60</b> /1 step]	
022	Initial Value of Upper Limit Count	
	[0 to 999999 / <b>500</b> / 1]	



041	Fill Addr Acl Info.	
	<p>This SP must be executed immediately after installation of an HDD unit in a basic machine that previously had no HDD. The first time the machine is powered on with the new HDD installed, the system automatically takes the address book from the NVRAM and writes it onto the new HDD. However, the new address book on the HDD can be accessed only by the system administrator at this stage. Executing this SP by the service technician immediately after power on grants full address book access to all users.</p> <p><b>Procedure</b></p> <ol style="list-style-type: none"> <li>1. Turn the machine off.</li> <li>2. Install the new HDD.</li> <li>3. Turn the machine on.</li> <li>4. The address book and its initial data are created on the HDD automatically. However, at this point the address book can be accessed by only the system administrator or key operator.</li> <li>5. Enter the SP mode and do SP5846 041. After this SP executes successfully, any user can access the address book.</li> </ol>	
043	Addr Book Media	
	Displays the slot number where an address book data is in. [0 to 30 / - /1]	
	0: Unconfirmed 1: SD Slot 1 2: SD Slot 2 4: USB Flash ROM	20: HDD 30: Nothing
046	Initialize All Setting & Addr Book	
	Initializes all settings and the address book.	
047	Initialize Local Address Book	
	Clears all of the address information from the local address book of a machine managed with UCS.	

049	Initialize LDAP Addr Book
	Push [Execute] to delete all items (this does not include user codes) in the LDAP address book that is controlled by UCS.
050	Initialize All Addr Book
	Clears everything (including users codes) in the directory information managed by UCS. However, the accounts and passwords of the system administrators are not deleted.
051	Backup All Addr Book
	Copies all directory information to the SD card. Do this SP before replacing the controller board or HDD. The operation may not succeed if the controller board or HDD is damaged.
052	Restore All Addr Book
	Copies back all directory information from the SD card to the flash ROM or HDD. Upload the address book from the old flash ROM or HDD with SP5846-51 before removing it. Do SP5846 52 after installing the new HDD.
053	Clear Backup Info
	Deletes the address book uploaded from the SD card in the slot 2. Deletes only the files uploaded for that machine. This feature does not work if the card is write-protected.  Note: After you do this SP, go out of the SP mode, turn the power off. Do not remove the SD card until the Power LED stops flashing.

060	Search Option	
	This SP uses bit switches to set up the fuzzy search options for the UCS local address book.	
	<b>Bit</b>	<b>Meaning</b>
	0	Checks both upper/lower case characters
	1	<b>Japan Only</b>
	2	
	3	
	4	--- Not Used ---
	5	--- Not Used ---
	6	--- Not Used ---
7	--- Not Used ---	
062	Complexity Option 1	
	<p>Use this SP to set the conditions for password entry to access the local address book. Specifically, this SP limits the password entry to upper case and sets the length of the password. [0 to 32 / 0 / 1step]</p> <p><b>Note</b></p> <ul style="list-style-type: none"> <li>▪ This SP does not normally require adjustment.</li> <li>▪ This SP is enabled only after the system administrator has set up a group password policy to control access to the address book.</li> </ul>	

063	Complexity Option 2
	<p>Use this SP to set the conditions for password entry to access the local address book. Specifically, this SP limits the password entry to lower case and defines the length of the password.</p> <p>[0 to 32 / 0 / 1step]</p> <p> <b>Note</b></p> <ul style="list-style-type: none"> <li>▪ This SP does not normally require adjustment.</li> <li>▪ This SP is enabled only after the system administrator has set up a group password policy to control access to the address book.</li> </ul>
064	Complexity Option 3
	<p>Use this SP to set the conditions for password entry to access the local address book. Specifically, this SP limits the password entry to numbers and defines the length of the password.</p> <p>[0 to 32 / 0 / 1step]</p> <p> <b>Note</b></p> <ul style="list-style-type: none"> <li>▪ This SP does not normally require adjustment.</li> <li>▪ This SP is enabled only after the system administrator has set up a group password policy to control access to the address book.</li> </ul>
065	Complexity Option 4
	<p>Use this SP to set the conditions for password entry to access the local address book. Specifically, this SP limits the password entry to symbols and defines the length of the password.</p> <p>[0 to 32 / 0 / 1step]</p> <p> <b>Note</b></p> <ul style="list-style-type: none"> <li>▪ This SP does not normally require adjustment.</li> <li>▪ This SP is enabled only after the system administrator has set up a group password policy to control access to the address book.</li> </ul>
094	Encryption Start
	<p>Shows the status of the encryption function of the address book on the LDAP server.</p> <p>[0 to 255 / 1 ] No default</p>

5848*	Web Service	
	5848-2 sets the 4-bit switch assignment for the access control setting. Setting of 0001 has no effect on access and delivery from Scan Router. 5848-100 sets the maximum size of images that can be downloaded. The default is equal to 1 gigabyte.	
004	Acc. Ctrl.: User Directory (Lower 4 Bits)	Switches access control on and off. 0000: OFF, 0001: ON
009	Acc. Ctrl.: Job Control (Lower 4 Bits)	
011	Acc. Ctrl: Device Management (Lower 4 Bits)	
022	Acc. Ctrl: User Administration (Lower 4 Bits)	
210	Setting: Log Type: Job 1	
	No information is available at this time.	
211	Setting: Log Type: Job 2	
	No information is available at this time.	
212	Setting: Log Type: Access	
	No information is available at this time.	
213	Setting: Primary Srv	
	No information is available at this time.	
214	Setting: Secondary Srv	
	No information is available at this time.	
215	Setting: Start Time	
	No information is available at this time.	
216	Setting: Interval Time	
	No information is available at this time.	
217	Setting: Timing	
	No information is available at this time.	

Appendix:  
Service  
Program  
Mode Tables

5849	Installation Date	
	Displays or prints the installation date of the machine.	
001	Display	The "Counter Clear Day" has been changed to "Installation Date" or "Inst. Date".
002	Switch to Print	Determines whether the installation date is printed on the printout for the total counter. [0 to 1 / <b>1</b> / -] 0: OFF (No Print) 1: ON (Print)
003	Total Counter	When the total number of pages that are made reaches this value, the current date becomes the 'official' installation date for this machine. [0 to 99999999 / <b>0</b> / 1]

5851*	Bluetooth	
	Sets the operation mode for the Bluetooth Unit. Press either key. <b>[0: Public]</b> / [1: Private]	

5856	Remote ROM Update	
002	When set to "1" allows reception of firmware data via the local port (IEEE 1284) during a remote ROM update. This setting is reset to zero after the machine is cycled off and on. Allows the technician to upgrade the firmware using a parallel cable [0 to 1 / <b>0</b> / 1 step] 0: Not allowed 1: Allowed	

5857	Save Debug Log
001	On/Off (1:ON 0:OFF)
	Switches on the debug log feature. The debug log cannot be captured until this feature is switched on. [0 to 1 / 0 / 1] 0: OFF, 1: ON
002	Target (2: HDD 3: SD)
	Selects the destination where the debugging information generated by the event selected by SP5858 will be stored if an error is generated [2 to 3 / 2 / 1] 2: HDD, 3: SD Card
005	Save to HDD
	Specifies the decimal key number of the log to be written to the hard disk.
006	Save to SD Card
	Specifies the decimal key number of the log to be written to the SD Card.
009	Copy HDD to SD Card (Latest 4 MB)
	Takes the most recent 4 MB of the log written to the hard disk and copies them to the SD Card. A unique file name is generated to avoid overwriting existing file names on the SD Card. Up to 4MB can be copied to an SD Card. 4 MB segments can be copied one by one to each SD Card.
010	Copy HDD to SD Card Latest 4 MB Any Key)
	Takes the log of the specified key from the log on the hard disk and copies it to the SD Card. A unique file name is generated to avoid overwriting existing file names on the SD Card. Up to 4 MB can be copied to an SD Card. 4 MB segments can be copied one by one to each SD Card. This SP does not execute if there is no log on the HDD with no key specified.

Appendix:  
Service  
Program  
Mode Tables

011	Erase HDD Debug Data
	Erases all debug logs on the HDD
012	Erase SD Card Debug Data
	Erases all debug logs on the SD Card. If the card contains only debugging files generated by an event specified by SP5858, the files are erased when SP5857 010 or 011 is executed. To enable this SP, the machine must be cycled off and on.
013	Free Space on SD Card
	Displays the amount of space available on the SD card.

5858*	Debug Save When	
	These SPs select the content of the debugging information to be saved to the destination selected by SP5857-002. SP5858-003 stores one SC specified by number.	
001*	Engine SC Error (0:OFF 1:ON)	Stores SC codes generated by copier engine errors.
002*	Controller SC Error (0:OFF 1:ON)	Stores SC codes generated by GW controller errors.
003*	Any SC Error	[0 to 65535 / 0 / 1step]
004*	Jam (0:OFF 1:ON)	Stores jam errors.

5859*	Debug Save Key No.	
001	Key 1	These SPs allow you to set up to 10 keys for log files for functions that use common memory on the controller board. [0 to 9999999 / 0 / 1]
002	Key 2	
003	Key 3	
004	Key 4	
005	Key 5	



006	Key 6	
007	Key 7	
008	Key 8	
009	Key 9	
010	Key 10	

5860*	SMTP/POP3/IMAP4
020	Partial Mail Receive Timeout
	[1 to 168 / <b>72</b> / 1 hour] Sets the amount of time to wait before saving a mail that breaks up during reception. The received mail is discarded if the remaining portion of the mail is not received during this prescribed time.
021	MDN Response RFC2298 Compliance
	Determines whether RFC2298 compliance is switched on for MDN reply mail. [0 to 1 / <b>1</b> / 1] 0: No, 1: Yes
022	SMTP Auth. From Field Replacement
	Determines whether the FROM item of the mail header is switched to the validated account after the SMTP server is validated. [0 to 1 / <b>0</b> / 1] 0: No. "From" item not switched. 1: Yes. "From" item switched.

Appendix:  
Service  
Program  
Mode Tables

025	SMTP Auth Direct Sending	
	Select the authentication method for SMPT. Bit 0: LOGIN Bit 1: PLAIN Bit 2: CRAM_MD5 Bit 3: DIGEST_MD5 Bit 4 to Bit 7: Not Used <b>Note</b> <ul style="list-style-type: none"> <li>This SP is activated only when SMTP authentication is enabled by UP mode.</li> </ul>	
026	S/MIME: MIME Header Setting	
	Selects the MIME header type of an E-mail sent by S/MIME. [0 to 2 / 0 / 1] 0: Microsoft Outlook Express standard 1: Internet Draft standard 2: RFC standard	
028	S/MIME: Authentication Check	
	When sending S/MIME mail, specifies whether to check the destination authentication. [0 to 1 / 0 / 1] 0: Not checked 1: Checked	

5866	E-Mail Report	
001	Report Validity	Enables or disables the E-mail alert function. [0 or 1 / 0 / -] 0: Enabled, 1: Disabled
005	Add Date Field	Adds or does not add the date field to the header of the alert mail. [0 or 1 / 0 / -] 0: Not added, 1: Added

5869	RAM Disk Setting	
001	Mail Function	Enables or disables the Mail function. [0 or 1 / 0 / - ] 0: Enabled, 1: Disabled

5870	Common Key Info Writing	
001	Writing	Writes to flash ROM the common proof for validating the device for @Remote specifications.
003	Initialize	Initializes the data area of the common proof for validating.

5873	SD Card Appli. Move	
	Allows you to move applications from one SD card another. For more, see "SD Card Appli Move" in the chapter "System Maintenance (Main Chapters).	
001	Move Exec	Executes the move from one SD card to another.
002	Undo Exec	This is an undo function. It cancels the previous execution.

5878	Option Setup	
001	Data Overwrite Security	Press [Execute] to initialize the Data Overwrite Security option for the copier. For more, see "DataOverwriteSecurity Unit" in the chapter "Installation".

5881	Fixed Phase Block Erasing	
	Detects the Fixed phrase.	

5887	SD Get Counter
	This SP determines whether the ROM can be updated.
001	<p>This SP sends a text file to an SD card inserted in SD card Slot 2 (lower slot). The operation stores. The file is stored in a folder created in the root directory of the SD card called SD_COUNTER. The file is saved as a text file (*.txt) prefixed with the number of the machine.</p> <ol style="list-style-type: none"> <li>1. Insert the SD card in SD card Slot 2 (lower slot).</li> <li>2. Select SP5887 then touch [EXECUTE].</li> </ol> <p>Touch [Execute] in the message when you are prompted.</p>

5888*	Personal Information Protect
	<p>Selects the protection level for logs. [0 to 1 / 0 / 1]</p> <p>0: No authentication, No protection for logs 1: No authentication, Protected logs (only an administrator can see the logs)</p>

5893	SDK Application Counter
	Displays the counter name of each SDK application.
001	SDK-1
002	SDK-2
003	SDK-3
004	SDK-4
005	SDK-5
006	SDK-6

5907	Plug & Play Maker/Model Name
	<p>Selects the brand name and the production name for Windows Plug &amp; Play. This information is stored in the NVRAM. If the NVRAM is defective, these names should be registered again.</p> <p>After selecting, press the "Original Type" key and "#" key at the same time. When the setting is completed, the beeper sounds five times.</p>

5919*	HDD Encryption
001	Display Operation State
	<p>Shows the status of the encryption function for the HDD.</p> <p>[0 or 1 / 0 / - ]</p> <p>0: Not Activated</p> <p>1: Activated</p>

5930	Meter Charge
001	Display Operation State
	<p>0: OFF</p> <p>1: ON</p>

Appendix:  
Service  
Program  
Mode Tables

5985	Device Setting	
	The NIC and USB support features are built into the GW controller. Use this SP to enable and disable these features. In order to use the NIC and USB functions built into the controller board, these SP codes must be set to "1".	
001	On Board NIC	<p>[0 to 2 / 0 / 1 /step]                      0: Disable, 1: Enable, 2: Function limitation                      When the "Function limitation" is set, "On board NIC" is limited only for the NRS or LDAP/NT authentication.</p> <p><b>Note</b></p> <ul style="list-style-type: none"> <li>Other network applications than @Remote or LDAP/NT authentication are not available when this SP is set to "2". Even though you can change the initial settings of those network applications, the settings do not work</li> </ul>
002	On Board USB	<p>[0 or 1 / 0 / 1/step]                      0: Disable, 1: Enable</p>

5990	SP Print Mode	
	Prints out the SMC sheets.	
001	All ( Data List)	
002	SP (Mode Data List)	
003	User Program	
004	Logging Data	
005	Diagnostic Report	
006	Non-Default	
007	NIB Summary	
008	Capture Log	
021	Copier User Program	
022	Scanner SP	

023	Scanner User Program
024	SDK/J Summary
025	SDK/J Application Info

5992	SP Text Mode
	Writes the SMC sheets into the SD card.
001	All ( Data List)
002	SP (Mode Data List)
003	User Program
004	Logging Data
005	Diagnostic Report
006	Non-Default
007	NIB Summary
008	Capture Log
021	Copier User Program
022	Scanner SP
023	Scanner User Program
024	SDK/J Summary
025	SDK/J Application Info
026	Print SP

Appendix:  
Service  
Program  
Mode Tables

### 3.7 ENGINE SP TABLES-6

#### 3.7.1 SP6-XXX: PERIPHERALS

6128	Punch Position: Sub Scan	
	Adjusts the punching position in the sub scan direction. (For D636/D637)	
001	2-Hole: DOM (Japan)	[-7.5 to 7.5 / <b>0</b> / 0.5 mm]
002	3-Hole: NA	
003	4-Hole: EU	
004	5-Hole: SCAN	
005	2-Hole: NA	

6129	Punch Position: Main Scan	
	Adjusts the punching position in the main scan direction. (For D636/D637)	
001	2-Hole: DOM (Japan)	[-2 to 2 / <b>0</b> / 0.4 mm]
002	3-Hole: NA	
003	4-Hole: EU	
004	4-Hole: SCAN	
005	2-Hole: NA	

6130*	Skew Correction: Buckle Adj.	
	Adjusts the paper buckle at the punch unit for each paper size. (For D636/D637)	
001	A3 SEF	[-5 to 5 / <b>0</b> / 0.25 mm]
002	B4 SEF	
003	A4 SEF	



004	A4 LEF	
005	B5 SEF	
006	B5 LEF	
007	DLT SEF	
008	LG SEF	
009	LT SEF	
010	LT LEF	
011	12" x 18"	
012	Other	

Appendix:  
Service  
Program  
Mode Tables

6131*	Skew Correction Control	
	Selects the skew correction control for each paper size. (For D636/D637)	
001	A3 SEF	[0 to 1 / 1 / 1 mm]
002	B4 SEF	
003	A4 SEF	
004	A4 LEF	
005	B5 SEF	
006	B5 LEF	
007	DLT SEF	
008	LG SEF	
009	LT SEF	
010	LT LEF	
011	12" x 18"	
012	Other	

6132*	Jogger Fence Fine Adj.	
	This SP adjusts the distance between the jogger fences and the sides of the stack on the finisher stapling tray in the (Booklet) Finisher D636/D637. The adjustment is done perpendicular to the direction of paper feed.	
001	A3 SEF	[-1.5 to 1.5 / <b>0</b> / 0.5 mm]
002	B4 SEF	
003	A4 SEF	
004	A4 LEF	
005	B5 SEF	
006	B5 LEF	
007	DLT SEF	
008	LG SEF	
009	LT SEF	
010	LT LEF	
011	12" x 18"	
012	Other	

6133*	Staple Position Adjustment	
	Adjusts the staple position for each finisher (D636/D637). + Value: Moves the staple position to the rear side. - Value: Moves the staple position to the front side. [-3.5 to 3.5 / <b>0</b> / 0.5 mm]	

6134*	Saddle Stitch Position Adj.	
	Use this SP to adjust the stapling position of the booklet stapler when paper is stapled and folded in the Booklet Finisher (D637).	
001	A3 SEF	[-3 to 3 / <b>0</b> / 0.2 mm] + Value: Shifts staple position toward the crease.
002	B4 SEF	

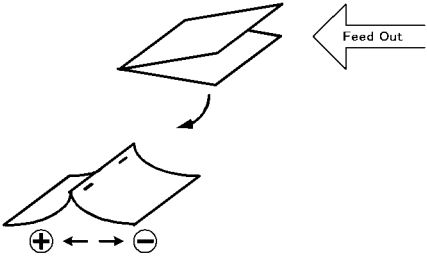
003	A4 SEF	<p>- Value: Shifts staple position away from the crease</p> 
004	B5 SEF	
005	DLT SEF	
006	LG SEF	
007	LT SEF	
008	12" x 18"	
009	Other	

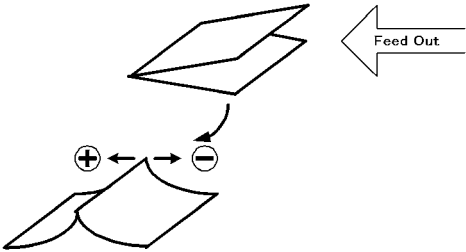
6135*	Folder Position Adj.	
	This SP corrects the folding position when paper is stapled and folded in the Booklet Finisher D637.	
001	A3 SEF	<p>[ -3 to 3 / 0 / 0.2 mm ]</p> <p>+ Value: Shifts staple position toward the crease.</p> <p>- Value: Shifts staple position away from the crease.</p> 
002	B4 SEF	
003	A4 SEF	
004	B5 SEF	
005	DLT SEF	
006	LG SEF	
007	LT SEF	
008	12" x 18"	
009	Other	

6136*	Book Fold Repeat	
	Sets the number of times that folding is done in the Booklet Finisher D637. [2 to 30 / 2 / 1 time/step]	

Appendix:  
Service  
Program  
Mode Tables

6137	Finisher Free Run	
	These SPs are used for the D588 or D636/D637.	
001	Free Run 1	D588: System free run D636/D637: Free run for paper edge stapling.
002	Free Run 2	D588: Free run for durability testing D636/D637: Not used
003	Free Run 3	Not used
004	Free Run 4	Not used

6139	Entrance Sensor	
	Display the signals received from sensors and switches of the (booklet) finisher. (D588) (p.3-165)	

6140	FIN (EUP) INPUT Check	
	Display the signals received from sensors and switches of the (booklet) finisher. (D636/D637) (p.3-165)	

6144	FIN (KIN) OUPUT Check	
	Display the signals received from sensors and switches of the (booklet) finisher. (D588) (p.3-176)	

6145	FIN (EUP) OUPUT Check	
	Display the signals received from sensors and switches of the (booklet) finisher. (D636/D637) (p.3-176)	

6148	Jogger Fine Adj.	
001	A3T	Adjusts the jogger location [Horizontal direction] [-1.5 to 1.5 / <b>0</b> / 0.5 /mm] *Jogger is optional equipment.
002	B4T	
003	A4T	
004	A4Y	
005	B5Y	
006	A5Y	
007	DLT-T	
008	LG-T	
009	LT-T	
010	LT-Y	
011	HLT-Y	
012	Other	

Appendix:  
 Service  
 Program  
 Mode Tables

6149*	Max. Pre-Stack Sheet	[0 to 3 / <b>3</b> / 1 sheets step]
	This SP sets the number of sheets sent to the pre-stack tray.  <b>Note</b> <ul style="list-style-type: none"> <li>▪ You may need to adjust this setting or switch it off when feeding thick or slick paper.</li> </ul>	

6150	Jogger Control	
001	Enables or disables the jogger. [0 to 1 / <b>0</b> / 1 /step]	

6830*	Extra Staples
	<p>More than the standard number of sheets can be stapled. This SP sets the additional number of sheets (This Setting + Standard Number = maximum number of sheets).</p> <ul style="list-style-type: none"> <li>▪ If the number of the maximum for staples is increased, and the mechanical warranty of the unit can be guaranteed, then the setting can take effect without changing the controller software.</li> <li>▪ However, assurance that mechanical performance can be guaranteed is required before changing the setting to increase the staple load for more than the maximum in the feed/exit specifications. Raising this setting without quality assurance could damage the machine.</li> </ul>
1	Staple positions other than booklet stapling
	[0 to 50 / <b>0</b> /1]
2	2 Booklet stapling
	[0 to 50 / <b>0</b> /1]

### 3.8 ENGINE SP TABLES-7

#### 3.8.1 SP7-XXX: DATA LOG

7401*	Total SC Counter
001	SC Counter
	Displays the total number of service calls that have occurred. This SC counter can be reset by executing SP7807 (SC/Jam Counter Reset).
002	Total SC Counter
	Displays the cumulative sum of service calls that have occurred. This SC counter cannot be reset by executing SP7807 (SC/Jam Counter Reset).

Appendix:  
Service  
Program  
Mode Tables

7403*	SC History	
001	Latest	Displays the most recent 10 service calls.
002	Latest 1	
003	Latest 2	
004	Latest 3	
005	Latest 4	
006	Latest 5	
007	Latest 6	
008	Latest 7	
009	Latest 8	
010	Latest 9	

7404*	SC991 History	
001	Latest	Displays the 10 most recently detected SC991 codes.
002	Latest 1	
003	Latest 2	
004	Latest 3	
005	Latest 4	
006	Latest 5	
007	Latest 6	
008	Latest 7	
009	Latest 8	
010	Latest 9	

7502*	Total Paper Jam	
001	Jam Counter	Displays the total number of paper jams. This SC counter can be reset by executing SP7807 (SC/Jam Counter Reset).
	Total Jam Counter	
002	Total Jam Counter	Displays the cumulative sum of paper jams. This SC counter cannot be reset by executing SP7807 (SC/Jam Counter Reset).
	Jam Counter	



7504*	Total Jams Location
	These SPs display the total number of paper jams by location. A "Check-in" (paper late) error occurs when the paper fails to activate the sensor at the precise time. A "Check-out" ("paper lag") paper jam occurs when the paper remains at the sensor for longer than the prescribed time.
001	At power On
003	Tray 1: On
004	Tray 2: On
005	Tray 3: On
006	Tray 4: On
007	LCT: On
008	Bypass: On
009	Duplex: On
011	Vertical Transport 1: On
012	Vertical Transport 2: On
013	Bank: Transport Sn 1: On
014	Bank: Transport Sn 2: On
017	Registration: On
019	Fusing Exit: On
020	Paper Exit: On
021	Bridge Exit On
022	Bridge Transport: On
024	Junction Gate Sensor: On

Engine SP Tables-7

025	Duplex Exit: On
026	Duplex Entrance: On (In)
027	Duplex Entrance: On (Out)
051	Vertical Transport 1: Off
052	Vertical Transport 2: Off
053	Bank Transport 1: Off
054	Bank Transport 2: Off
057	Registration Sensor: Off
058	LCT Feed Sensor: Off
060	Paper Exit: Off
061	Bridge: Exit: Off
062	Bridge: Transport: Off
064	Junction Gate Sensor: Off
065	Duplex Exit: Off
066	Duplex Entrance: Off (In)
067	Duplex Entrance: Off (Out)
100	Finisher Entrance: KIN
101	Finisher Shift Tray Exit: KIN
102	Finisher Staple: KIN
103	Finisher Exit: KIN
105	Finisher Tray Lift Motor: KIN
106	Finisher Jogger Motor: KIN

107	Finisher Shift Motor: KIN
108	Finisher Staple Motor: KIN
109	Finisher Exit Motor: KIN
191	Finisher Entrance: EUP
192	Finisher Proof Exit: EUP
193	Finisher Shift Tray Exit: EUP
194	Finisher Staple Exit: EUP
195	Finisher Exit: EUP
198	Finisher Folder: EUP
199	Finisher Tray Motor: EUP
200	Finisher Jogger Motor: EUP
201	Finisher Shift Motor: EUP
202	Finisher Staple Moving Motor: EUP
203	Finisher Staple Motor: EUP
204	Finisher Folder Motor: EUP
206	Finisher Punch Motor: EUP

Appendix:  
Service  
Program  
Mode Tables

7506*	Jam Count by Paper Size	
005	A4 LEF	Displays the total number of copy jams by paper size.
006	A5 LEF	
014	B5 LEF	
038	LT LEF	
044	HLT LEF	

Engine SP Tables-7

132	A3 SEF	
133	A4 SEF	
134	A5 SEF	
141	B4 SEF	
142	B5 SEF	
160	DLT SEF	
164	LG SEF	
166	LT SEF	
172	HLT SEF	
255	Others	

7507*	Plotter Jam History	
001	Last	<p>Displays the copy jam history (the most recent 10 jams)</p> <p>Sample Display:</p> <p>CODE:007</p> <p>SIZE:05h</p> <p>TOTAL:0000334</p> <p>DATE: Mon Mar 15 11:44:50 2000</p> <p>where:</p> <p>CODE is the SP7504-*** number (see above).</p> <p>SIZE is the ASAP paper size code in hex.</p> <p>TOTAL is the total jam error count (SP7502)</p> <p>DATE is the date the jams occurred.</p>
002	Latest 1	
003	Latest 2	
004	Latest 3	
005	Latest 4	
006	Latest 5	
007	Latest 6	
008	Latest 7	
009	Latest 8	
010	Latest 9	

Size	Code	Size	Code	Size	Code
A4 (S)	05	A3 (L)	84	DLT (L)	A0
A5 (S)	06	A4 (L)	85	LG (L)	A4
B5 (S)	0E	A5 (L)	86	LT (L)	A6
LT (S)	26	B4 (L)	8D	HLT (L)	AC
HLT (S)	2C	B5 (L)	8E	Others	FF

7801	ROM No./Firmware Version
	This SP code displays the firmware versions of all ROMs in the system, including the mainframe, the ARDF, and peripheral devices.

7803*	PM Counter Display	
	Displays the PM counter since the last PM.	
001	Paper	[0 to 999999 / 0 / 1 page]
	Displays the paper counter (pages)	
002	Page: PCD	[0 to 999999 / 0 / 1 page]
	Displays the PCD (Drum and Development unit) counter (pages)	
003	Page: Transfer	[0 to 999999 / 0 / 1 page]
	Displays the transfer unit counter (pages).	
004	Page: Fuser	[0 to 999999 / 0 / 1 page]
	Displays the fusing unit counter (pages).	
005	Rotation: PCD	[0 to 999999999 / 0 / 1 mm ]
	Displays the PCD rotation counter (distance).	

Appendix:  
Service  
Program  
Mode Tables

006	Rotation: Transfer	[0 to 999999999 / 0 / 1 mm ]
	Displays the transfer unit rotation counter (distance).	
007	Rotation: Fuser	[0 to 999999999 / 0 / 1 mm ]
	Displays the fuser unit rotation counter (distance).	
008	Rotation(%): PCD	[0 to 255 / 0 / 1 %]
	Displays the PCD (%) rotation counter (Distance/PM).	
009	Rotation(%):Transfer	[0 to 255 / 0 / 1 %]
	Displays the transfer unit (%) rotation counter (distance/PM).	
010	Rotation(%):Fuser	[0 to 255 / 0 / 1 %]
	Displays the fuser unit (%) rotation counter (distance/PM).	
011	Rotation(%):Web	[0 to 255 / 0 / 1 %]
	Displays the web unit (%) rotation counter (distance/PM).	

7804	PM Counter Reset	
	Resets the PM counter. Touch [Execute] two times > "Completed" > [Exit]	
001	Paper	
	Resets the PM counter of the paper.	
002	PCD	
	Resets the PM counter of the PCD (Drum and Development unit except developer).	
003	Transfer	
	Resets the PM counter of the transfer unit.	

004	Fuser
	Resets the PM counter of the fuser unit.
005	Web
	Reset the PM counter of the web unit.
006	All Clear
	Resets all PM counter

7805	Parts Counter	
001	Page: OPC	[0 to 999999 / 0 / 1 page]
	Displays the parts counter (pages) of the OPC.	
002	Page: Charge Roller	[0 to 999999 / 0 / 1 page]
	Displays the parts counter (pages) of the charge roller.	
003	Page: Developer	[0 to 999999 / 0 / 1 page]
	Displays the parts counter (pages) of the developer.	
004	Page: Belt Blade	[0 to 999999 / 0 / 1 page]
	Displays the parts counter (pages) of the transfer belt cleaning blade.	
005	Page: Heat Roller	[0 to 999999 / 0 / 1 page]
	Displays the parts counter (pages) of the hot roller.	
006	Page: Pressure Roller	[0 to 999999 / 0 / 1 page]
	Displays the parts counter (pages) of the pressure roller.	
007	Page: Cleaning Roller	[0 to 999999 / 0 / 1 page]
	Displays the parts counter (pages) of the cleaning roller.	

Appendix:  
Service  
Program  
Mode Tables

008	Page: Thermistor	[0 to 999999 / 0 / 1 page]
	Displays the parts counter (pages) of the thermistors.	
009	Page: Stripper	[0 to 999999 / 0 / 1 page]
	Displays the parts counter (pages) of the strippers.	
010	Rotation: OPC	[0 to 999999999 / 0 / 1 mm ]
	Displays the parts counter (rotations) of the OPC.	
011	Rotation: Charge Roller	[0 to 999999999 / 0 / 1 mm ]
	Displays the parts counter (rotations) of the charge roller.	
012	Rotation: Developer	[0 to 999999999 / 0 / 1 mm ]
	Displays the parts counter (rotations) of the developer.	
013	Rotation: Belt Blade	[0 to 999999999 / 0 / 1 mm ]
	Displays the parts counter (rotations) of the transfer belt, blade.	
014	Rotation: Heat Roller	[0 to 999999999 / 0 / 1 mm ]
	Displays the parts counter (rotations) of the hot roller.	
015	Rotation: Pressure Roller	[0 to 999999999 / 0 / 1 mm ]
	Displays the parts counter (rotations) of the pressure roller.	
016	Rotation: Cleaning Roller	[0 to 999999999 / 0 / 1 mm ]
	Displays the parts counter (rotations) of the cleaning roller.	
017	Rotation: Thermistor	[0 to 999999999 / 0 / 1 mm ]
	Displays the parts counter (rotations) of the thermistors.	
018	Rotation: Stripper	[0 to 999999999 / 0 / 1 mm ]
	Displays the parts counter (rotations) of the strippers.	
019	Page(%): Web	[0 to 255 / 0 / 1 %]
	Displays the parts counter (rotations/PM %) of the cleaning web.	



7806	Counter Clear	
001	OPC	
	Resets the parts counter of the OPC.	
002	Charge Roller	
	Resets the parts counter of the charge roller.	
003	Developer	
	Resets the parts counter of the developer.	
004	Belt: Blade	
	Resets the parts counter of the transfer belt cleaning blade.	
005	Heat Roller	
	Resets the parts counter of the hot roller.	
006	Pressure Roller	
	Resets the parts counter of the pressure roller.	
007	Cleaning Roller	
	Resets the parts counter of the cleaning roller.	
008	Web	
	Resets the parts counter of the cleaning web.	
009	Thermistor	
	Resets the parts counter of the thermistors.	
010	Stripper	
	Resets the parts counter of the strippers.	
011	All Clear	
	Resets all parts counters.	

**Appendix:  
 Service  
 Program  
 Mode Tables**

7807	SC/Jam Counter Reset	
	Resets the SC and jam counters. To reset, press Execute on the touch panel. This SP does not reset the jam history counters: SP7507, SP7508.	

7832	Self-Diagnose Result Display	
	Execute to open the "Self-Diagnostics Result Display" to view details about errors. Use the keys in the display on the touch-panel to scroll through all the information. If no errors have occurred, you will see the "No Error" message on the screen.	

7836	Total Memory Size	
	Displays the memory capacity of the controller system.	

7853	Replacement Counter	
001	PCD	[0 to 255 / 0 / 1 ]
	Displays the replacement counter of the PCD (Drum and Development unit).	
002	Transfer	[0 to 255 / 0 / 1 ]
	Displays the replacement counter of the transfer unit.	
003	Fuser	[0 to 255 / 0 / 1 ]
	Displays the replacement counter of the fusing unit.	
004	Web	[0 to 255 / 0 / 1 ]
	Displays the replacement counter of the cleaning web.	

7856*	zero cross	[0 to 255 / <b>60</b> / 1 ]
	Stores and displays the detected zero cross frequency of the main ac power supply from the wall socket.	

7901	Assert Info. <b>DFU</b>	
	These SP numbers display the results of the occurrence of the most recent SC code generated by the machine.	
001*	File Name	Module name
002*	Number of Lines	Number of the lines where error occurred.
003*	Location	Value

Appendix:  
Service  
Program  
Mode Tables

7904	Near End Setting	
001*	PCD	Toner Near End timing setting
002*	Transfer	[0 to 2/ 1 / 1 /step] 0: Earlier
003*	Fuser	1: Normal 2: Later

7906	Prev Counter	
001	Page: PCD	[0 to 999999 / <b>0</b> / 1 page]
	Displays the counter (pages) of the previous PCD	
002	Page: Transfer	[0 to 999999 / <b>0</b> / 1 page]
	Displays the previous counter (pages) of the previous transfer unit.	
003	Page: Fuser	[0 to 999999 / <b>0</b> / 1 page]
	Displays the previous counter (pages) of the previous fusing unit.	

004	Rotation: PCD	[0 to 999999999 / 0 / 1 mm ]
	Displays the previous counter (rotations) of the previous PCD	
005	Rotation: Transfer	[0 to 999999999 / 0 / 1 mm ]
	Displays the previous counter (rotations) of the previous transfer unit.	
006	Rotation: Fuser	[0 to 999999999 / 0 / 1 mm ]
	Displays the previous counter (rotations/PM %) of the previous fusing unit.	
007	Rotation(%):PCD	[0 to 255 / 0 / 1 mm]
	Displays the previous counter (rotations/PM %) of the previous PCD	
008	Rotation(%):Transfer	[0 to 255 / 0 / 1 mm]
	Displays the previous counter (rotations/PM %) of the previous transfer unit.	
009	Rotation(%):Fuser	[0 to 255 / 0 / 1 mm]
	Displays the previous counter (rotations/PM %) of the previous fusing unit.	
010	Rotation(%):Web	[0 to 255 / 0 / 1 %]
	Displays the previous counter (rotations/PM %) of the previous cleaning web.	

7950	Replacement Date	
001	PCD	
	Displays the replacement date of the PCD.	
002	Transfer	
	Displays the replacement date of the transfer unit.	
003	Fuser	
	Displays the replacement date of the fusing unit.	
004	Web	
	Displays the replacement date of the web unit.	

7951	Remaining Counter	
001	PCD(Page)	[0 to 255 / <b>255</b> / 1 days]
	Displays the remaining counter (pages) of the PCD.	
002	Transfer(Page)	[0 to 255 / <b>255</b> / 1 days]
	Displays the remaining counter (pages) of the transfer unit.	
003	Fuser(Page)	[0 to 255 / <b>255</b> / 1 days]
	Displays the remaining counter (pages) of the fusing unit.	
005	PCD(Rotation)	[0 to 255 / <b>255</b> / 1 days]
	Displays the remaining counter (rotations) of the PCD.	
006	Transfer(Rotation)	[0 to 255 / <b>255</b> / 1 days]
	Displays the remaining counter (rotations) of the transfer unit.	
007	Fuser(Rotation)	[0 to 255 / <b>255</b> / 1 days]
	Displays the remaining counter (rotations) of the fusing unit.	
009	PCD (%)	[0 to 255 / <b>100</b> / 1 %]
	Displays the remaining counter (%) of the PCD.	
010	Transfer (%)	[0 to 255 / <b>100</b> / 1 %]
	Displays the remaining counter (%) of the transfer unit.	
011	Fuser (%)	[0 to 255 / <b>100</b> / 1 %]
	Displays the remaining counter (%) of the fusing unit.	
013	Web (%)	[0 to 255 / <b>100</b> / 1 %]
	Displays the remaining counter (%) of the cleaning web.	

7952	PM Yield Setting	
	Sets the each yield of the following.	
⇒ 001	PCD(Page)	[0 to 99999999 / <b>80000</b> / 1 sheet]
	Sets the PM yield of the PCD (Pages).	
⇒ 002	Transfer(Page)	[0 to 99999999 / <b>90000</b> / 1 sheet]
	Sets the PM yield of the transfer unit (Pages).	
⇒ 003	Fuser(Page)	[0 to 99999999 / <b>90000</b> / 1 sheet]
	Sets the PM yield of the fusing unit (Pages).	
005	PCD(Rotation)	C2b: [0 to 999999999 / <b>71990000</b> / 1 mm] C2c: [0 to 999999999 / <b>75500000</b> / 1 mm]
	Sets the PM yield of the PCD (Rotations).	
006	Transfer(Rotation)	C2b: [0 to 999999999 / <b>62770000</b> / 1 mm] C2c: [0 to 999999999 / <b>65420000</b> / 1 mm]
	Sets the PM yield of the transfer unit (Rotations).	
007	Fuser(Rotation)	C2b: [0 to 999999999 / <b>54880000</b> / 1 mm] C2b: [0 to 999999999 / <b>55800000</b> / 1 mm]
	Sets the PM yield of the fusing unit (Rotations).	
009	Web (%)	[0 to 255 / <b>92</b> / 1 %]
	Sets the PM yield (%) of the web unit.	

7953	Operation Env Log	
001	T<10	[0 to 99999999 / 0 / 1 mm]
	Displays the PCU rotation distance in the environment: T<10°C	
002	10<=T<=17	[0 to 99999999 / 0 / 1 mm]
	Displays the PCU rotation distance in the environment: 10°C<=T<=17°C	
003	17<T<23	[0 to 99999999 / 0 / 1 mm]
	Displays the PCU rotation distance in the environment: 17<=T<=23	
004	23<=T<=27	[0 to 99999999 / 0 / 1 mm]
	Displays the PCU rotation distance of the environment: 23<=T<=27	
005	27<=T<=32	[0 to 99999999 / 0 / 1 mm]
	Displays the PCU rotation distance of the environment: 27<=T<=32	
006	32<T	[0 to 99999999 / 0 / 1 mm]
	Displays the PCU rotation distance of the environment: 32<T	
7954	Env Log Clear	
	Resets the environment logs (SP7953).	

Appendix:  
Service  
Program  
Mode Tables

## 3.9 ENGINE SP TABLES-8

### 3.9.1 SP8-XXX: DATA LOG2

Many of these counters are provided for features that are currently not available, such as sending color faxes, and so on. However, here are some Group 8 codes that when used in combination with others, can provide useful information.

SP Numbers	What They Do
SP8211 to SP8216	The number of pages scanned to the document server.
SP8401 to SP8406	The number of pages printed from the document server
SP8691 to SP8696	The number of pages sent from the document server

Specifically, the following questions can be answered:

- How is the document server actually being used?
- What application is using the document server most frequently?
- What data in the document server is being reused?

Most of the SPs in this group are prefixed with a letter that indicates the mode of operation (the mode of operation is referred to as an "application"). Before reading the Group 8 Service Table, make sure that you understand what these prefixes mean.

Prefixes	What it means	
T:	Total: (Grand Total).	Grand total of the items counted for all applications (C, F, P, etc.).
P:	Print application.	
O:	Other applications (external network applications, for example)	Refers to network applications such as Web Image Monitor. Utilities developed with the SDK (Software Development Kit) will also be counted with this group in the future.

The Group 8 SP codes are limited to 17 characters, forced by the necessity of displaying them on the small LCDs of printers and faxes that also use these SPs. Read over the list of abbreviations below and refer to it again if you see the name of an SP that you do not understand.

#### Key for Abbreviations



Abbreviation	What it means
/	"By", e.g. "T:Jobs/Apl" = Total Jobs "by" Application
>	More (2> "2 or more", 4> "4 or more")
AddBook	Address Book
Apl	Application
B/W	Black & White
Bk	Black
C	Cyan
ColCr	Color Create
ColMode	Color Mode
Comb	Combine
Comp	Compression
Deliv	Delivery
DesApl	Designated Application. The application (Copy, Fax, Scan, Print) used to store the job on the document server, for example.
Dev Counter	Development Count, no. of pages developed.
Dup, Duplex	Duplex, printing on both sides
Emul	Emulation
FC	Full Color
FIN	Post-print processing, i.e. finishing (punching, stapling, etc.)
Full Bleed	No Margins
GenCopy	Generation Copy Mode

Abbreviation	What it means
GPC	Get Print Counter. For jobs 10 pages or less, this counter does not count up. For jobs larger than 10 pages, this counter counts up by the number that is in excess of 10 (e.g., for an 11-page job, the counter counts up 11-10 =1)
IFax	Internet Fax
ImgEdt	Image Edit performed on the original with the copier GUI, e.g. border removal, adding stamps, page numbers, etc.
K	Black (YMCK)
LS	Local Storage. Refers to the document server.
LSize	Large (paper) Size
Mag	Magnification
MC	One color (monochrome)
NRS	New Remote Service, which allows a service center to monitor machines remotely. "NRS" is used overseas, "CSS" is used in Japan.
Org	Original for scanning
OrgJam	Original Jam
Palm 2	Print Job Manager/Desk Top Editor: A pair of utilities that allows print jobs to be distributed evenly among the printers on the network, and allows files to be moved around, combined, and converted to different formats.
PC	Personal Computer
PGS	Pages. A page is the total scanned surface of the original. Duplex pages count as two pages, and A3 simplex count as two pages if the A3/DLT counter SP is switched ON.
PJob	Print Jobs
Ppr	Paper
PrtJam	Printer (plotter) Jam

Abbreviation	What it means
PrtPGS	Print Pages
R	Red (Toner Remaining). Applies to the wide format model A2 only. This machine is under development and currently not available.
Rez	Resolution
SC	Service Code (Error SC code displayed)
Scn	Scan
Sim, Simplex	Simplex, printing on 1 side.
S-to-Email	Scan-to-E-mail
SMC	SMC report printed with SP5990. All of the Group 8 counters are recorded in the SMC report.
Svr	Server
TonEnd	Toner End
TonSave	Toner Save
TXJob	Send, Transmission
YMC	Yellow, Magenta, Cyan
YMCK	Yellow, Magenta, Cyan, Black

**Note**

- All of the Group 8 SPs are able to reset by “SP5 801 1 Memory All Clear”.

8001	T:Total Jobs	*CTL	These SPs count the number of times each application is used to do a job. [0 to 99999999 / 0 / 1]
8004	P:Total Jobs	*CTL	

- These SPs reveal the number of times an application is used, not the number of pages processed.
- When an application is opened for image input or output, this counts as one job.
- Interrupted jobs (paper jams, etc.) are counted, even though they do not finish.
- Only jobs executed by the customer are counted. Jobs executed by the customer engineer using the SP modes are not counted.
- When using secure printing (when a password is required to start the print job), the job is counted at the time when either "Delete Data" or "Specify Output" is specified.
- When the customer prints a report (user code list, for example), the O: counter increments.

8061	T:FIN Jobs	*CTL	[0 to 99999999 / 0 / 1]
	These SPs total the finishing methods. The finishing method is specified by the application.		
8064	P:FIN Jobs	*CTL	[0 to 99999999 / 0 / 1]
	These SPs total finishing methods for print jobs only. The finishing method is specified by the application.		
8067	O:FIN Jobs	*CTL	[0 to 99999999 / 0 / 1]
	These SPs total finishing methods for jobs executed by an external application, over the network. The finishing method is specified by the application.		
806x 1	Sort	Number of jobs started in Sort mode. When a stored copy job is set for Sort and then stored on the document server, the L: counter increments. (See SP8-066-1)	
806x 2	Stack	Number of jobs started out of Sort mode.	
806x 3	Staple	Number of jobs started in Staple mode.	
806x 4	Booklet	Number of jobs started in Booklet mode. If the machine is in staple mode, the Staple counter also increments.	

8 06x 5	Z-Fold	Number of jobs started In any mode other than the Booklet mode and set for folding (Z-fold).
806x 6	Punch	Number of jobs started in Punch mode. When Punch is set for a print job, the P: counter increments. (See SP8-064-6.)
806x 7	Other	(Reserved)
806x 8	Inside-Flod	Not used
806x 9	Three-In-Fold	Not used
806x 10	Three-OUT-Fold	Not used
806x 11	Four-Fold	Not used
806x 12	KANNON-Fold	Not used
806x 13	Perfect-Bind	Not used
806x 14	Ring-Bind	Not used

8071	T:Jobs/PGS	*CTL	[0 to 99999999 / 0 / 1]
	These SPs count the number of jobs broken down by the number of pages in the job, regardless of which application was used.		
8074	P:Jobs/PGS	*CTL	[0 to 99999999 / 0 / 1]
	These SPs count and calculate the number of print jobs by size based on the number of pages in the job.		
8077	O:Jobs/PGS	*CTL	[0 to 99999999 / 0 / 1]
	These SPs count and calculate the number of "Other" application jobs (Web Image Monitor, Palm 2, etc.) by size based on the number of pages in the job.		
807x 1	1 Page	8 07x 8	21 to 50 Pages
807x 2	2 Pages	8 07x 9	51 to 100 Pages
807x 3	3 Pages	8 07x 10	101 to 300 Pages

Engine SP Tables-8

807x 4	4 Pages	8 07x 11	301 to 500 Pages
807x 5	5 Pages	8 07x 12	501 to 700 Pages
807x 6	6 to 10 Pages	8 07x 13	701 to 1000 Pages
807x 7	11 to 20 Pages	8 07x 14	1001 to Pages

- Interrupted jobs (paper jam, etc.) are counted, even though they do not finish.
- If a job is paused and re-started, it counts as one job.
- If the finisher runs out of staples during a print and staple job, then the job is counted at the time the error occurs.
- When printing the first page of a job from within the document server screen, the page is counted.

8381	T:Total PrtPGS	*CTL	<p>These SPs count the number of pages printed by the customer. The counter for the application used for storing the pages increments.</p> <p>[0 to 99999999 / 0 / 1]</p> <p>The L: counter counts the number of pages stored from within the document server mode screen at the operation panel. Pages stored with the Store File button from within the Copy mode screen go to the C: counter.</p>
8384	P:Total PrtPGS	*CTL	
8387	O:Total PrtPGS	*CTL	

- When the A3/DLT double count function is switched on with SP5104, 1 A3/DLT page is counted as 2.
- When several documents are merged for a print job, the number of pages stored are counted for the application that stored them.
- These counters are used primarily to calculate charges on use of the machine, so the following pages are not counted as printed pages:
  - Blank pages in a duplex printing job.
  - Blank pages inserted as document covers, chapter title sheets, and slip sheets.
  - Reports printed to confirm counts.
  - All reports done in the service mode (service summaries, engine maintenance reports, etc.)
  - Test prints for machine image adjustment.
  - Error notification reports.
  - Partially printed pages as the result of a copier jam.

8391	LSize PrtPGS	*CTL	[0 to 99999999 / 0 / 1]
	<p>These SPs count pages printed on paper sizes A3/DLT and larger.  <b>Note:</b> In addition to being displayed in the SMC Report, these counters are also displayed in the User Tools display on the copy machine.</p>		

8411	Prints/Duplex	*CTL	<p>This SP counts the amount of paper (front/back counted as 1 page) used for duplex printing. Last pages printed only on one side are not counted.                  [0 to 99999999 / 0 / 1]</p>
------	---------------	------	--

8421	T:PrtPGS/Dup Comb	*CTL	[0 to 99999999 / 0 / 1]
	<p>These SPs count by binding and combine, and n-Up settings the number of pages processed for printing. This is the total for all applications.</p>		
8424	P:PrtPGS/Dup Comb	*CTL	[0 to 99999999 / 0 / 1]
	<p>These SPs count by binding and combine, and n-Up settings the number of pages processed for printing by the printer application.</p>		
8427	O:PrtPGS/Dup Comb	*CTL	[0 to 99999999 / 0 / 1]
	<p>These SPs count by binding and combine, and n-Up settings the number of pages processed for printing by Other applications</p>		
842x 1	Simplex> Duplex		
842x 4	Simplex Combine		
842x 5	Duplex Combine		
842x 6	2in1		2 pages on 1 side (2-Up)
842x 7	4 in1		4 pages on 1 side (4-Up)
842x 8	6 in1		6 pages on 1 side (6-Up)
842x 9	8 in1		8 pages on 1 side (8-Up)
842x 10	9 in1		9 pages on 1 side (9-Up)

**Appendix:  
 Service  
 Program  
 Mode Tables**

Engine SP Tables-8

842x 11	16 in1	16 pages on 1 side (16-Up)
842x 12	Booklet	
842x 13	Magazine	
842x 14	2-in-1 + Booklet	
842x 15	4-in-1 + Booklet	
842x 16	6-in-1 + Booklet	
842x 17	8-in-1 + Booklet	
842x 18	9-in-1 + Booklet	
842x 19	2-in-1 + Magazine	
842x 20	4-in-1 + Magazine	
842x 21	6-in-1 + Magazine	
842x 22	8-in-1 + Magazine	
842x 23	9-in-1 + Magazine	
842x 24	16-in-1 + Magazine	

- These counts (SP8 421 to SP8 427) are especially useful for customers who need to improve their compliance with ISO standards for the reduction of paper consumption.
- Pages that are only partially printed with the n-Up functions are counted as 1 page.
- Here is a summary of how the counters work for Booklet and Magazine modes:



Booklet		Magazine	
Original Pages	Count	Original Pages	Count
1	1	1	1
2	2	2	2
3	2	3	2
4	2	4	2
5	3	5	4
6	4	6	4
7	4	7	4
8	4	8	4

8431	T:PrtPGS/ImgEdt	*CTL	[0 to 99999999 / 0 / 1]
	These SPs count the total number of pages output with the three features below, regardless of which application was used.		
8434	P:PrtPGS/ImgEdt	*CTL	[0 to 99999999 / 0 / 1]
	These SPs count the total number of pages output with the three features below with the print application.		
8437	O:PrtPGS/ImgEdt	*CTL	[0 to 99999999 / 0 / 1]
	These SPs count the total number of pages output with the three features below with Other applications.		
843x 1	Cover/Slip Sheet	Total number of covers or slip sheets inserted. The count for a cover printed on both sides counts 2.	
843x 2	Series/Book	The number of pages printed in series (one side) or printed as a book with booklet right/left pagination.	

Engine SP Tables-8

843x 3	User Stamp	The number of pages printed where stamps were applied, including page numbering and date stamping.
--------	------------	--

8441	T:PrtPGS/Ppr Size	*CTL	[0 to 99999999 / 0 / 1]
	These SPs count by print paper size the number of pages printed by all applications.		
8444	P:PrtPGS/Ppr Size	*CTL	[0 to 99999999 / 0 / 1]
	These SPs count by print paper size the number of pages printed by the printer application.		
8447	O:PrtPGS/Ppr Size	*CTL	[0 to 99999999 / 0 / 1]
	These SPs count by print paper size the number of pages printed by Other applications.		
844x 1	A3		
844x 2	A4		
844x 3	A5		
844x 4	B4		
844x 5	B5		
844x 6	DLT		
844x 7	LG		
844x 8	LT		
844x 9	HLT		
844x 10	Full Bleed		
844x 254	Other (Standard)		
844x 255	Other (Custom)		

- These counters do not distinguish between LEF and SEF.

8451	PrtPGS/Ppr Tray		
	These SPs count the number of sheets fed from each paper feed station.		
001	Bypass Tray	*CTL	Bypass Tray [0 to 99999999 / 0 / 1]
002	Tray 1	*CTL	Copier [0 to 99999999 / 0 / 1]
003	Tray 2	*CTL	
004	Tray 3	*CTL	Paper Tray Unit (Option) [0 to 99999999 / 0 / 1]
005	Tray 4	*CTL	
006	Tray 5	*CTL	LCT (Option) [0 to 99999999 / 0 / 1]
007	Tray 6	*CTL	Currently not used.
008	Tray 7	*CTL	Currently not used.
009	Tray 8	*CTL	Currently not used.
010	Tray 9	*CTL	Currently not used.
011	Tray 10	*CTL	Currently not used.
012	Tray 11	*CTL	Currently not used.
013	Tray 12	*CTL	Currently not used.
014	Tray 13	*CTL	Currently not used.
015	Tray 14	*CTL	Currently not used.
016	Tray 15	*CTL	Currently not used.

Appendix:  
Service  
Program  
Mode Tables

8461	T:PrtPGS/Ppr Type	*CTL	[0 to 99999999 / 0 / 1]
	<p>These SPs count by paper type the number pages printed by all applications.</p> <ul style="list-style-type: none"> <li>▪ These counters are not the same as the PM counter. The PM counter is based on feed timing to accurately measure the service life of the feed rollers. However, these counts are based on output timing.</li> <li>▪ Blank sheets (covers, chapter covers, slip sheets) are also counted.</li> <li>▪ During duplex printing, pages printed on both sides count as 1, and a page printed on one side counts as 1.</li> </ul>		
8464	P:PrtPGS/Ppr Type	*CTL	[0 to 99999999 / 0 / 1]
	<p>These SPs count by paper type the number pages printed by the printer application.</p>		
846x 1	Normal		
846x 2	Recycled		
846x 3	Special		
846x 4	Thick		
846x 5	Normal (Back)		
846x 6	Thick (Back)		
846x 7	OHP		
846x 8	Other		

8471	PrtPGS/Mag		
	These SPs count by magnification rate the number of pages printed.		
001	< 49%	*CTL	[0 to 99999999 / 0 / 1]
002	50% to 99%	*CTL	
003	100%	*CTL	
004	101% to 200%	*CTL	
005	201% <	*CTL	

- Counts are done for magnification adjusted for pages, not only on the operation panel but performed remotely with an external network application capable of performing magnification adjustment as well.
- Magnification adjustments done with printer drivers with PC applications such as Excel are also counted.
- Magnification adjustments done for adjustments after they have been stored on the document server are not counted.
- Magnification adjustments performed automatically during Auto Reduce/Enlarge copying are counted.
- The magnification rates of blank cover sheets, slip sheets, etc. are automatically assigned a rate of 100%.

8481	T:PrtPGS/TonSave	*CTL	[0 to 99999999 / 0 / 1]
8484	P:PrtPGS/TonSave	*CTL	
<p>These SPs count the number of pages printed with the Toner Save feature switched on.</p> <p><b>Note:</b> These SPs return the same results as this SP is limited to the Print application.</p>			

Appendix:  
Service  
Program  
Mode Tables

8511	T:PrtPGS/Emul	*CTL	[0 to 99999999 / 0 / 1]	
	These SPs count by printer emulation mode the total number of pages printed.			
8514	P:PrtPGS/Emul	*CTL	[0 to 99999999 / 0 / 1]	
	These SPs count by printer emulation mode the total number of pages printed.			
8 51x 1	RPCS			
8 51x 2	RPDL			
8 51x 3	PS3			
8 51x 4	R98			
8 51x 5	R16			
8 51x 6	GL/GL2			
8 51x 7	R55			
8 51x 8	RTIFF			
8 51x 9	PDF			
8 51x 10	PCL5e/5c			
8 51x 11	PCL XL			
8 51x 12	IPDL-C			
8 51x 13	BM-Links			Japan Only
8 51x 14	Other			
8 51x 15	IPDS			

- SP8 511 and SP8 514 return the same results as they are both limited to the Print application.
- Print jobs output to the document server are not counted.

8521	T:PrtPGS/FIN	*CTL	[0 to 99999999 / 0 / 1]
	These SPs count by finishing mode the total number of pages printed by all applications.		
8524	P:PrtPGS/FIN	*CTL	[0 to 99999999 / 0 / 1]
	These SPs count by finishing mode the total number of pages printed by the Print application.		
8 52x 1	Sort		
8 52x 2	Stack		
8 52x 3	Staple		
8 52x 4	Booklet		
8 52x 5	Z-Fold		
8 52x 6	Punch		
8 52x 7	Other		
8 52x 8	Inside Fold	Half-Fold (FM2) (Multi Fold Unit)	
8 52x 9	Three-IN-Fold	Letter Fold-in (FM4) (Multi Fold Unit)	
8 52x 10	Three-OUT-Fold	Letter Fold-out (FM3) (Multi Fold Unit)	
8 52x 11	Four Fold	Double Parallel Fold (FM5) (Multi Fold Unit)	
8 52x 12	KANNON-Fold	Gate Fold (FM6) (Multi Fold Unit)	
8 52x 13	Perfect-Bind	Perfect Binder	
8 52x 14	Ring-Bind	Ring Binder	

 **Note**

- If stapling is selected for finishing and the stack is too large for stapling, the unstapled pages are still counted.
- The counts for staple finishing are based on output to the staple tray, so jam recoveries are counted.

Engine SP Tables-8

8531	Staples	*CTL	This SP counts the amount of staples used by the machine. [0 to 99999999 / 0 / 1]
------	---------	------	--

8551	T:FIN Books		
001	Perfect-Bind	*CTL	Not used
002	Ring-Bind	*CTL	

8554	T:FIN Books		
001	Perfect-Bind	*CTL	Not used
002	Ring-Bind	*CTL	

8561	T:A Sheet Of Paper		
001	Total: Over A3/DLT	*CTL	[0 to 999999999 / 0 / 1]
002	Total: Under A3/DLT	*CTL	
003	Duplex: Over A3/DLT	*CTL	
004	Duplex: Under A3/DLT	*CTL	

8564	P:A Sheet Of Paper		
001	Total: Over A3/DLT	*CTL	[0 to 999999999 / 0 / 1]
002	Total: Under A3/DLT	*CTL	
003	Duplex: Over A3/DLT	*CTL	
004	Duplex: Under A3/DLT	*CTL	



8567	O:A Sheet Of Paper		
001	Total: Over A3/DLT	*CTL	[0 to 99999999 / 0 / 1]
002	Total: Under A3/DLT	*CTL	
003	Duplex: Over A3/DLT	*CTL	
004	Duplex: Under A3/DLT	*CTL	

8581	T:Counter		
	These SPs count the total output broken down by color output, regardless of the application used. In addition to being displayed in the SMC Report, these counters are also displayed in the User Tools display on the copy machine.		
001	Total	*CTL	[0 to 99999999 / 0 / 1]

8591	O:Counter		
	These SPs count the totals for A3/DLT paper use, number of duplex pages printed, and the number of staples used. These totals are for Other (O:) applications only.		
001	A3/DLT	*CTL	[0 to 99999999 / 0 / 1]
002	Duplex	*CTL	

8601	T: Coverage Counter		
	These SPs count the total coverage for each color and the total printout pages for each printing mode.		
001	B/W	*CTL	[0 to 2147483647 / 0 / 1% /step]
011	B/W Printing Pages	*CTL	[0 to 99999999 / 0 / 1]

Appendix:  
Service  
Program  
Mode Tables

Engine SP Tables-8

8604	P:Coverage Counter		
	-		
001	BW	*CTL	[0 to 2147483647 / 0 / 1% /step]

8617	SDK Apli Counter		
	These SPs count the total printout pages for each SDK application.		
001	SDK-1	*CTL	[0 to 99999999 / 0 / 1]
002	SDK-2	*CTL	
003	SDK-3	*CTL	
004	SDK-4	*CTL	
005	SDK-5	*CTL	
006	SDK-6	*CTL	

8621	Func Use Counter		
	-		
001	Function-001	*CTL	[0 to 99999999 / 0 / 1]
002	Function-002	*CTL	
003	Function-003	*CTL	
004	Function-004	*CTL	
005	Function-005	*CTL	
006	Function-006	*CTL	
007	Function-007	*CTL	
008	Function-008	*CTL	
009	Function-009	*CTL	

010	Function-010	*CTL	
011	Function-011	*CTL	[0 to 99999999 / 0 / 1]
012	Function-012	*CTL	
013	Function-013	*CTL	
014	Function-014	*CTL	
015	Function-015	*CTL	
016	Function-016	*CTL	
017	Function-017	*CTL	
018	Function-018	*CTL	
019	Function-019	*CTL	
020	Function-020	*CTL	
021	Function-021	*CTL	
022	Function-022	*CTL	
023	Function-023	*CTL	
024	Function-024	*CTL	
025	Function-025	*CTL	
026	Function-026	*CTL	
027	Function-027	*CTL	
028	Function-028	*CTL	
029	Function-029	*CTL	
030	Function-030	*CTL	

**Appendix:  
 Service  
 Program  
 Mode Tables**

Engine SP Tables-8

031	Function-031	*CTL	[0 to 99999999 / 0 / 1]
032	Function-032	*CTL	
033	Function-033	*CTL	
034	Function-034	*CTL	
035	Function-035	*CTL	
036	Function-036	*CTL	
037	Function-037	*CTL	
038	Function-038	*CTL	
039	Function-039	*CTL	
040	Function-040	*CTL	
041	Function-041	*CTL	[0 to 99999999 / 0 / 1]
042	Function-042	*CTL	
043	Function-043	*CTL	
044	Function-044	*CTL	
045	Function-045	*CTL	
046	Function-046	*CTL	
047	Function-047	*CTL	
048	Function-048	*CTL	
049	Function-049	*CTL	
050	Function-050	*CTL	
051	Function-051	*CTL	[0 to 99999999 / 0 / 1]
052	Function-052	*CTL	

053	Function-053	*CTL		
054	Function-054	*CTL		
055	Function-055	*CTL		
056	Function-056	*CTL		
057	Function-057	*CTL		
058	Function-058	*CTL		
059	Function-059	*CTL		
060	Function-060	*CTL		
061	Function-061	*CTL		[0 to 99999999 / 0 / 1]
062	Function-062	*CTL		
063	Function-063	*CTL		
064	Function-064	*CTL		

8771	Dev Counter		
	These SPs count the frequency of use (number of rotations of the development rollers) for black and other color toners.		
001	Total	*CTL	[0 to 99999999 / 0 / 1]

8781	Toner_Bottle_Info.	*ENG	[0 to 99999999 / 0 / 1]
	These SPs display the number of already replaced toner bottles. <b>NOTE:</b> Currently, the data in SP7-833-011 through 014 and the data in SP8-781-001 through 004 are the same.		
001	Toner: BK	The number of black-toner bottles	

Engine SP Tables-8

8801	Toner Remain		
	<p>These SPs display the percent of toner remaining for each color. This SP allows the user to check the toner supply at any time.</p> <p><b>Note:</b> This precise method of measuring remaining toner supply (1% steps) is better than other machines in the market that can only measure in increments of 10 (10% steps).</p>		
001	K	*CTL	[0 to 100 / 0 / 1% /step]

8811	Eco Counter		
	-		
001	Eco Total	*CTL	[0 to 99999999 / 0 / 1]
004	Duplex	*CTL	
005	Combine	*CTL	
008	Duplex (%)	*CTL	
009	Combine (%)	*CTL	
010	Paper Cut (%)	*CTL	
101	Eco Totalr>Last	*CTL	[0 to 99999999 / 0 / 1]
104	Duplex>Last	*CTL	
105	Combine>Last	*CTL	
108	Duplex (%):Last	*CTL	[0 to 100 / 0 / 1% /step]
109	Combine (%):Last	*CTL	
110	Paper Cut (%):Last	*CTL	

8851	Cvr Cnt: 0-10%		
	These SPs display the number of scanned sheets on which the coverage of each color is from 0% to 10%.		
011	0 to 2%: BK	*ENG	[0 to 99999999 / 0 / 1]
021	3 to 4%: BK	*ENG	[0 to 99999999 / 0 / 1]
031	5 to 7%: BK	*ENG	[0 to 99999999 / 0 / 1]
041	8 to 10%: BK	*ENG	[0 to 99999999 / 0 / 1]

8861	CVr Cnt: 11-20%		
	These SPs display the number of scanned sheets on which the coverage of each color is from 11% to 20%.		
001	BK	*ENG	[0 to 99999999 / 0 / 1]

8871	CVr Cnt: 21-30%		
	These SPs display the number of scanned sheets on which the coverage of each color is from 21% to 30%.		
001	BK	*ENG	[0 to 99999999 / 0 / 1]

8881	CVr Cnt: 31%-		
	These SPs display the number of scanned sheets on which the coverage of each color is 31% or higher.		
001	BK	*ENG	[0 to 99999999 / 0 / 1]

8891	Page/Toner Bottle		
	These SPs display the amount of the remaining current toner for each color.		
001	BK	*ENG	[0 to 99999999 / 0 / 1]

Appendix:  
Service  
Program  
Mode Tables

Engine SP Tables-8

8901	Page/Toner_prev1		
	These SPs display the amount of the remaining previous toner for each color.		
001	BK	*ENG	[0 to 99999999 / 0 / 1]

8911	Page/Toner_prev2		
	These SPs display the amount of the remaining 2nd previous toner for each color.		
001	BK	*ENG	[0 to 99999999 / 0 / 1]

8921	Cvr Cnt/Total		
	Displays the total coverage and total printout number for each color.		
001	Coverage (%) Bk	*CTL	[0 to 2147483647 / 0 / 1% /step]
011	Coverage /P: Bk	*CTL	[0 to 99999999 / 0 / 1]

8941	Machine Status	*CTL	[0 to 99999999 / 0 / 1]
	These SPs count the amount of time the machine spends in each operation mode. These SPs are useful for customers who need to investigate machine operation for improvement in their compliance with ISO Standards.		
001	Operation Time	Engine operation time. Does not include time while controller is saving data to HDD (while engine is not operating).	
002	Standby Time	Engine not operating. Includes time while controller saves data to HDD. Does not include time spent in Energy Save, Low Power, or Off modes.	
003	Energy Save Time	Includes time while the machine is performing background printing.	



004	Low Power Time	Includes time in Energy Save mode with Engine on. Includes time while machine is performing background printing.
005	Off Mode Time	Includes time while machine is performing background printing. Does not include time machine remains powered off with the power switches.
006	SC	Total time when SC errors have been staying.
007	PrtJam	Total time when paper jams have been staying during printing.
008	OrgJam	Total time when original jams have been staying during scanning.
009	Supply PM Unit End	Total time when toner end has been staying

8961	Electricity Status		
	-		
001	Ctrl Standby Time	*CTL	[0 to 99999999 / 0 / 1]
002	STR Time	*CTL	
003	Main Power Off Time	*CTL	
004	Reading and Printing Time	*CTL	
005	Printing Time	*CTL	[0 to 99999999 / 0 / 1]
006	Reading Time	*CTL	
007	Eng Waiting Time	*CTL	
008	Low Power State Time	*CTL	
009	Silent State Time	*CTL	

Engine SP Tables-8

8999	Admin. Counter List		
	-		
001	Total		[0 to 999999999 / 0 / 1]
007	Printer: BW		
012	A3/DLT		
013	Duplex		
027	Printer: BW(%)		[0 to 2147483647 / 0 / 1]

## 3.10 INPUT CHECK

### 3.10.1 COPIER

When entering the Input Check mode, 8 digits display the result for a section. Each digit corresponds to a different device as shown in the table.

Bit No.	7	6	5	4	3	2	1	0
Result	0 or 1	0 or 1	0 or 1	0 or 1	0 or 1	0 or 1	0 or 1	0 or 1

5803	Input Check		
	Description	Reading	
		0	1
001	Tray 1: Paper Size Sensor	See the table 1 following this table.	
002	Tray 1: Tray Set Sensor	Set	Not set
003	Tray 1: Paper Lift Sensor	Not upper limit	Upper limit
004	Tray 1: Paper End Sensor	No paper	Paper remaining
005	Tray 1: Paper Height Sensor 1	See the table 2 following this table.	
006	Tray 1: Paper Height Sensor 2		
007	Tray 2: Paper Size Sensor	See the table 1 following this table.	
008	Tray 2: Tray Set Sensor	Set	Not set
009	Tray 2: Paper Lift Sensor	Not upper limit	Upper limit
010	Tray 2: Paper End Sensor	No paper	Paper remaining
011	Tray 2: Paper Height Sensor 1	See the table 2 following this table.	
012	Tray 2: Paper Height Sensor 2		

Input Check

013	Tray 1: Paper Feed Sensor	Paper detected	No paper detected
014	Tray 2: Paper Feed Sensor	Paper detected	No paper detected
015	Tray 3: Paper Feed Sensor	Paper detected	No paper detected
016	Tray 4: Paper Feed Sensor	Paper detected	No paper detected
017	LCT: Paper Feed Sensor	No paper detected	Paper detected
018	Relay Sensor 1	Paper detected	No paper detected
019	Relay Sensor 2	Paper detected	No paper detected
020	Relay Sensor 3	No paper detected	Paper detected
021	Relay Sensor 4	No paper detected	Paper detected
022	Relay Sensor: LCT	No paper detected	Paper detected
023	By-pass: Paper End Sensor	Not end	Paper end
024	By-pass: Paper Size Sensor	See the table 3 following this table.	
025	Registration Sensor	Paper detected	No paper detected
026	Fusing Exit Sensor	No paper detected	Paper detected
027	Fusing Entrance Sensor	Paper detected	No paper detected
028	Junction Gate Relay Sensor	Paper detected	No paper detected
029	Exit Sensor	Paper detected	No paper detected
030	Paper Overflow Sensor	Not full	Full
031	Right Cover Open/Close	Close	Open
032	Duplex Unit Open/Close	Open	Close
033	Duplex Entrance Sensor	Paper detected	No paper detected
034	Duplex Exit Sensor	Paper detected	No paper detected

035	Bank Right Cover Open/Close	Close	Open
036	Tray Cover Open/Close	Close	Open
037	LCT Set	Set	Not set
038	Bridge/Exit Tray: Exit Sensor	Paper detected	No paper detected
039	Bridge/Exit Tray: Relay Sensor	Paper detected	No paper detected
040	Bridge/Exit/Shift: Set Detection	Set	Not set
041	Bridge/Exit Tray: Left Guide Open/Close	Close	Open
042	Bridge/Exit Tray: Right Guide Open/Close	Close	Open
043	Transfer Belt Unit HP Sensor	Not HP	HP
046	Fusing Unit Set	Set (Bit1)	Not set (Bit1)
047	Toner Overflow Sensor	Not full	Full
048	Interlock Detection 1	Right or front door is open.	Right or front door is close.
049	Interlock Detection 2	Right or front door is open.	Right or front door is close.
055	New U. Det. :PCDU		
057	Cleaning Web End	Not end	End
058	Punch Switch		
065	Bypass Tray Paper Length Detection	Paper detected	No paper detected
200	Scanner HP Sensor	Not HP	HP
201	Platen Cover Sensor	Open	Close

**Table 1: Paper Height Sensor**

0: Deactivated, 1: Activated (actuator inside sensor)

Remaining paper	Paper height sensor 1	Paper height sensor 2
Full	0	0
Nearly full	1	0
Near end	1	1
Almost empty	0	1

**Table 2: Paper Size Switch**

Switch 1 is used for the tray set detection.

0: Pushed, 1: Not pushed

Models		Switch Location		
North America	Europe/Asia	4	3	2
11" x 17" SEF*1 (A3 SEF)	A3 SEF*1 (11" x 17" SEF)	0	0	1
8.5" x 14" SEF *2 (B4 SEF)	B4 SEF *2 (8.5" x 14" SEF)	0	0	0
A4 SEF	A4 SEF	1	1	0
8.5" x 11" SEF	8.5" x 11" SEF	1	1	1
B5 SEF	B5 SEF	0	1	1
11" x 8 1/2" LEF*3 (A4 LEF)	A4 LEF*3 (11" x 8 1/2" LEF)	1	0	0
10.5" x 7.25" LEF*4 (B5 LEF)	B5 LEF*4 (10.5" x 7.25" LEF)	0	1	0
A5 LEF	A5 LEF	1	0	1

\*1: The machine detects either 11" x 17" SEF or A3 SEF, depending on the setting of SP 5-181-002 (Tray 1) or -006 (Tray 2).

\*2: The machine detects either 8.5" x 14" SEF or B4 SEF, depending on the setting of SP 5-181-003 (Tray 1) or -007 (Tray 2).

\*3: The machine detects either 11" x 8 1/2" LEF or A4 LEF, depending on the setting of SP 5-181-001 (Tray 1) or -005 (Tray 2).

\*4: The machine detects either B5 LEF or 10.5" x 7.25" LEF, depending on the setting of SP 5-181-004 (Tray 1) or -008 (Tray 2)..

**Table 3: Paper Size (By-pass Table)**

0: Pushed, 1: Not pushed

Models		Bit No.			
North America	Europe/Asia	3	2	1	0
11" x 17" SEF*1 (11" x 8.5" LEF)	A3 SEF*1 (A4 LEF)	1	1	1	0
11" x 17" SEF*1 (11" x 8.5" LEF)	A3 SEF*1 (A4 LEF)	1	1	0	0
8.5" x 11" SEF*1 (8.5" x 11" SEF*2)	A4 SEF*1 (A5 LEF)	1	1	0	1
8.5" x 11" SEF*1 (8.5" x 11" SEF*2)	A4 SEF*1 (B5 LEF)	1	0	0	1
5.5" x 8.5" SEF	A5 SEF	1	0	1	1
5.5" x 8.5" SEF	A5 SEF	0	0	1	1
5.5" x 8.5" SEF	A6 SEF	0	1	1	1
5.5" x 8.5" SEF	A6 SEF	1	1	1	1

**Note**

- \*1: When the machine determines that the paper feed direction is "LEF", it considers that the paper size is bracketed size.

**APS Original Size Detection**

Original Size		Length Sensor			Width Sensor		SP4-301 display
Metric version	Inch version	L3	L2	L1	W1	W2	
A3	11" x 17"	O	O	O	O	O	00011111
B4	10" x 14"	O	O	O	O	X	00011110
F4 8.5" x 13", 8.25" x 13", or 8" x 13" SP 5126 controls the size that is detected	8.5" x 14"	O	O	O	X	X	00011100
A4 LEF	8.5" x 11"	X	X	X	O	O	00000011
B5 LEF	-	X	X	X	O	X	00000010
A4 SEF	11" x 8.5"	X	O	O	X	X	00001100
B5 SEF	-	X	X	O	X	X	00000100
A5 LEF/ SEF	5.5" x 8.5", 8.5" x 5.5"	X	X	X	X	X	00000000



### 3.10.2 OPTIONS

#### 3000/2000-Sheet (Booklet) Finisher (D636/D637)

6140	Bit	Description	Reading	
			0	1
001		Entrance Sensor	No paper detected	Paper detected
002		Proof Exit Sensor	No paper detected	Paper detected
003		Proof Full Detection Sensor	Not Full	Full
004		Upper Tray Exit Sensor	No paper detected*1	Paper detected*1
005		Staple Exit Sensor	No paper detected	Paper detected
006		Shift Roller HP Sensor	Not HP	HP
007		Shift Exit Sensor	No paper detected	Paper detected
008		Exit Guide Plate HP Sensor	Not HP	HP
009		Lower Tray Height Sensor	No paper detected	Paper detected
010		Upper Tray Height Sensor	No paper detected	Paper detected
011		Upper Tray Full Sensor	Not Full	Full
012		Stack Roller HP Sensor	Not HP	HP
013		Jogger HP Sensor	Not HP	HP
014		Feed Out Belt HP Sensor	HP	Not HP
015		Stapling Tray Paper Sensor	No paper detected	Paper detected
016		Corner Stapler HP Sensor	Not HP	HP
017		Stapler Rotation HP Sensor	Not HP	HP
018		Upper Tray Limit SW	Not Limit	Limit
019		Door Switch	Closed	Open

Input Check

6140	Bit	Description	Reading	
			0	1
020		Corner Stapler Operation	Not HP	HP
021		Staple Detection	No staple detected	Staple detected
022		Staple Dip Detection	No staple detected	Staple detected
023		Punch Movement HP Sensor	Not HP	HP
024		Paper Position Slide HP Sensor	Not HP	HP
025		Paper Position Sensor	No paper detected	Paper detected
026		Punch Full Sensor	Not Full	Full
027		Punch HP Sensor	Not HP	HP
028		Punch DIP SW 1	See *1	
029		Punch DIP SW 2	See *1	
030		Stack Junction Gate HP Sensor	Not HP	HP
031		Stack Present Sensor	No paper detected	Paper detected
032		Clamp Roller HP Sensor	Not HP	HP
033		Fold Entrance Sensor	No paper detected	Paper detected
034		Bottom Fence HP Sensor	Not HP	HP
035		Fold Cam HP Sensor	Not HP	HP
036		Fold Plate HP Sensor	Not HP	HP
037		Fold Unit Exit Sensor	No paper detected	Paper detected
038		Lower Tray Full Sensor: Front	No paper detected*2	Paper detected*2
039		Lower Tray Full Sensor: Rear	No paper detected*2	Paper detected*2
040		Booklet Stapler 1: Operation	Not HP	HP
041		Booklet Stapler 1: Staple In (Front)	No staple detected	Staple detected

6140	Bit	Description	Reading	
			0	1
042		Booklet Stapler 1: Staple In (Leading Edge)	No staple detected	Staple detected
043		Booklet Stapler 1: Operation (Rotation/Rear)	Not HP	HP
044		Booklet Stapler 1: Staple In (Rear)	No staple detected	Staple detected
045		Booklet Stapler 1: Staple In (Leading Edge/Rear)	No staple detected	Staple detected
046		Upper Tray Full Sensor: 3000	Not Full	Full
047		Exit Jogger HP Sensor: Front	-	-
048		Exit Jogger HP Sensor: Rear	-	-
049		Exit Jogger HP Sensor: Upper	-	-

\*1: Combination of DIP SW 1 and SW 2

DIP SW 1	DIP SW 2	Punch Type
0	0	Japan
1	0	Europe
0	1	North America
1	1	North Europe

\*2: Please refer to "Lower Tray (D637 Only)" in the Service Manual for the "3000/2000 (Booklet) Finisher".

**1000-Sheet Finisher (D588)**

6139	Bit	Description	Reading	
			0	1
001		Entrance Sensor	Paper detected	No paper detected
002		Shift Exit Sensor (Lower Tray Exit Sensor)	No paper detected	Paper detected
003		Staple Entrance Sensor (Stapler Tray Entrance Sensor)	Paper detected	No paper detected
004		Staple Moving HP Sensor (Stapler HP Sensor)	Not HP	HP
005		Jogger HP Sensor (Jogger Fence HP Sensor)	Not HP	HP
006		Stack Feed-out Belt HP Sensor	HP	Not HP
007		Staple Tray Paper Sensor	No paper detected	Paper detected
008		Staple Rotation Sensor (Staple Rotation HP Sensor)	Not HP	HP
009		Staple Sensor	Staple detected	No staple detected
010		Staple READY Detection	Staple detected	No staple detected
011		Exit Guide Plate HP (Exit Guide Plate HP Sensor)	Not HP	HP

6139	Bit	Description	Reading	
			0	1
012		Shift HP Sensor	Not HP	HP
013		Paper Sensor (Stack Height Sensor)	No output tray detected	Output tray detected
014		Tray Lower Sensor (Lower Tray Lower Limit Sensor)	Lower limit	Not lower limit
015		Proof Full Sensor (Paper Limit Sensor)	Not full	Full

## 3.11 OUTPUT CHECK

### 3.11.1 COPIER

5804	Output Check	
001	Exit Motor: 350	Paper exit motor (Mainframe)
002	Exit Motor: 175	
003	Exit Motor: 230	
004	Exit Motor: 180	
005	Exit Motor: 154	
006	Exit Motor: 90	
007	Feed Motor: 300	Paper feed motor (Mainframe)
008	Feed Motor: 255	
009	Feed Motor: 230	
010	Feed Motor: 215	
011	Feed Motor: 180	
012	Feed Motor: 154	
013	Feed Motor: 90	Paper feed motor (Optional paper feed unit)
014	Bank: Feed Motor: 300	
015	Bank: Feed Motor: 255	
016	Bank: Feed Motor: 230	
017	Bank: Feed Motor: 215	
018	Bank: Feed Motor: 180	

5804	Output Check	
019	Bank: Feed Motor: 154	
020	Bank: Feed Motor: 90	
021	LCT: Feed Motor: 300	Paper feed motor (Optional LCT)
022	LCT: Feed Motor: 255	
023	LCT: Feed Motor: 230	
024	LCT: Feed Motor: 215	
025	LCT: Feed Motor: 180	
026	LCT: Feed Motor: 154	
027	LCT: Feed Motor: 90	
028	Paper Feed Clutch 1	
029	Paper Feed Clutch 2	
030	Bank: Paper Feed Clutch 3	Paper feed clutch 3/4 (Optional paper feed unit)
031	Bank: Paper Feed Clutch 4	
032	LCT: Paper Feed Clutch	Paper feed clutch (Optional LCT)
033	Pick-up Solenoid 1	Pick-up Solenoid 1/2 (Mainframe)
034	Pick-up Solenoid 2	
035	Bank: Pick-up Solenoid 3	Pick-up Solenoid 3/4 (Optional paper feed unit)
036	Bank: Pick-up Solenoid 4	
037	LCT: Pick-up Solenoid	Pick-up Solenoid (LCT)
038	Tray Lift Motor 1: Up	-
039	Tray Lift Motor 1: Down	

Output Check

5804	Output Check	
040	Tray Lift Motor 2: Up	
041	Tray Lift Motor 2: Down	
042	Paper Tray Lock Solenoid	Not used
043	Bank: Paper Tray Lock Solenoid	Tray lock solenoid (Optional paper feed unit)
044	Registration Motor: 230	-
045	Registration Motor: 180	
046	Registration Motor: 154	
047	Registration Motor: 90	
048	Exit: Junction Gate Solenoid	Junction gate 1 solenoid
049	Duplex: Inverter Gate Solenoid	Not used
050	Duplex Inverter Motor: Fwd: 230	-
051	Duplex Inverter Motor: Fwd: 180	
052	Duplex Inverter Motor: Fwd: 154	
053	Duplex Inverter Motor: Fwd: 90	
054	Duplex Inverter Motor: Rev: 230	
055	Duplex Inverter Motor: Rev: 180	
056	Duplex Inverter Motor: Rev: 154	
057	Duplex Inverter Motor: Rev: 90	
058	Duplex/By-pass Motor: Fwd: 230	-
059	Duplex/By-pass Motor: Fwd: 180	



5804	Output Check	
060	Duplex/By-pass Motor: Fwd: 154	
061	Duplex/By-pass Motor: Fwd: 90	
062	Duplex/By-pass Motor: Rev: 230	
063	Duplex/By-pass Motor: Rev: 180	
064	Duplex/By-pass Motor: Rev: 154	
065	Duplex/By-pass Motor: Rev: 90	
066	By-pass Feed Clutch	-
067	By-pass Pick-up Solenoid	-
068	Bridge/Exit Tray: Drive Motor: 230	Drive motor (Bridge unit)
069	Bridge/Exit Tray: Drive Motor: 180	
070	Bridge/Exit Tray: Drive Motor: 154	
071	Bridge/Exit Tray: Drive Motor: 90	
072	Bridge/Exit Tray: Junction Gate Solenoid	Junction Gate Solenoid (Bridge unit)
073	Bridge/Exit Tray: Drive Motor: Reset	-
074	Bridge/Exit Tray: Drive Motor: Enable	-
075	Bridge: Cooling Fan Motor	Not used
076	Transfer Belt Contact Motor	-
077	OPC Motor: 230	Drum motor
078	OPC Motor: 180	
079	OPC Motor: 154	
080	OPC Motor: 90	

Output Check

5804	Output Check	
081	Transfer/Development Motor: 230	
082	Transfer/Development Motor: 180	
083	Transfer/Development Motor: 154	
084	Transfer/Development Motor: 90	
085	Fusing Motor: 230	
086	Fusing Motor: 180	
087	Fusing Motor: 154	
088	Fusing Motor: 90	
089	Development Puddle Motor	-
090	PTL Control	-
091	Fusing Fan Motor: High	Fusing exhaust fan motor
092	Fusing Fan Motor: Low	
093	Exhaust Fan Motor: High	Exhaust fan motor
094	Exhaust Fan Motor: Low	
095	Duct Fan Motor	Cooling fan motor
096	Exit Fan Motor: High	Paper exit cooling fan motor
097	Exit Fan Motor: Low	
098	PSU Fan Motor	-
100	Polygon Motor: 230	
101	Polygon Motor: 180	

5804	Output Check	
102	Polygon Motor: 154	
103	Polygon Motor: 90	
104	LD 1	-
105	LD 2	
106	Toner Bottle Motor: Fwd	Toner supply motor
107	Quenching Lamp	-
108	Charge Bias	-
109	Development Bias	-
110	Transfer Belt Voltage	-
111	ID Sensor LED	-
115	Cleaning Web Motor	Web motor
117	CTL Cooling FAN	Controller fan

**3.11.2 1000-SHEET FINISHER (D588)**

6144	Output Check	
	Display	Description
001	Upper Relay Motor	Upper Transport Motor
002	Lower Relay Motor	Lower Transport Motor
003	Exit Motor	-
004	Proof Junction Gate SOL	Tray Junction Gate Solenoid
005	Lower Tray Lift Motor	-
006	Jogger Fence Motor	-
007	Stapler Motor	-
008	Stapler Hammer	-
009	Stapler Junction Gate Solenoid	-
010	Positioning Roller Solenoid	-
011	Stack Feed-out Motor	-
012	Shift Motor	-
013	Exit Guide Plate Motor	-

**3.11.3 3000 /2000-SHEET (BOOKLET) FINISHER (D636/D637)**

6145	Output	
	Display	Description
001	Entrance Motor	-
002	Upper Transport Motor	-
003	Lower Transport Motor	-
004	Upper/Proof Tray Exit Motor	-
005	Clamp Roller Retraction Motor	-
006	Shift Roller Motor	-
007	Exit Guide Plate Motor	-
008	Upper Tray Lift Motor	-
009	Stacking Sponge Roller Motor	-
010	Jogger Fence Motor	-
011	Feed Out Belt Motor	-
012	Corner Stapler Movement Motor	-
013	Corner Stapler Rotation Motor	-
014	Corner Stapler	-
015	Proof Junction Gate Solenoid	-
016	Stapling Tray Junction Gate Solenoid	-
017	Stapling Edge Pressure Plate Solenoid	-
018	Positioning Roller Solenoid	-
019	Booklet Pressure Roller Solenoid	-
020	Stack Junction Gate Motor	-

Output Check

021	Fold Unit Bottom Fence Lift Motor	-
022	Booklet Stapler: Front	-
023	Booklet Stapler: Rear	-
024	Fold Plate Motor	-
025	Fold Roller Motor	-
026	Positioning Roller Motor	-
027	Punch Drive Motor	-
028	Punch Movement Motor	-
029	Paper Position Sensor Slide Motor	-
030	Exit Jogger Motor: Front	-
031	Exit Jogger Motor: Rear	-
032	Exit Jogger Motor Release Motor	-

## 3.12 TEST PATTERN PRINTING

Printing Test pattern: SP2-109

Some of these test patterns are used for copy image adjustments but most are used primarily for design testing.

**Note**

- Do not operate the machine until the test pattern is printed out completely. Otherwise, an SC occurs.
1. Enter the SP mode and select **SP2-109-003**.
  2. Enter the number for the test pattern that you want to print and press [#].
  3. When you want to select the single color of Magenta, Yellow or Cyan for printing a test pattern, select the color with SP2-109-005 (2: Magenta, 3: Yellow, 4: Cyan).
  4. When you want to change the density of printing a test pattern, select the density with SP2-109-006 to -009 for each color.

**Note**

- If you select "0" with SP2-109-006 to -009, the color to be adjusted to "0" does not come up on a test pattern.
5. When you are prompted to confirm your selection, touch "Yes" to select the test pattern for printing.
  6. Touch "Copy Window" to open the copy window, then select the settings for the test print (paper size etc.).

**Note**

- If you want to use black and white printing, touch "Black & White" on the LCD. If you want to use color printing, touch "Full Colour" on the LCD.
7. Press the "Start" key to start the test print.
  8. After checking the test pattern, touch "SP Mode" on the LCD to return to the SP mode display.
  9. Reset all settings to the default values.
  10. Touch "Exit" twice to exit SP mode.

No.	Pattern	No.	Pattern
0	None	11	Independent Pattern (1-dot)
1	Vertical Line (1dot)	12	Independent Pattern (2-dot)
2	Vertical Line (2dot)	13	Independent Pattern (4-dot)
3	Horizontal Line (1dot)	14	Triming Area

## Test Pattern Printing

4	Horizontal Line (2dot)	16	Tooth Check (Horizontal)
5	Grid Vertical Line	17	Band (Horizontal)
6	Grid Horizontal Line	18	Band (Vertical)
7	Grid Pattern Small	19	Checker Flag Pattern
8	Grid Pattern Large	20	Grayscale (Vertical Margin)
9	Argyle Pattern Small	21	Grayscale (Horizontal Margin)
10	Argyle Pattern Large	23	Full Dot Pattern



## ⇒ 3.14 SP5749 IMPORT/EXPORT

### 3.14.1 IMPORT/EXPORT

5749	Import/Export	
1	Import	[- / - / -] Target: [System] [Printer] [Fax] [Scanner] Option: [Unique] [Secret] Crypt config: [Encryption] [Execute]
101	Export	[- / - / -] Option: [Unique] Crypt config: [Encryption] Encryption key (if selected) [Execute]
251	Export Result Print (SP)	[- / - / -] [Execute]
252	Import Result Print (SP)	[- / - / -] [Execute]

Appendix:  
Service  
Program  
Mode Tables

### 3.14.2 DATA THAT CAN BE IMPORTED AND EXPORTED:

- Copier / Document Server Features
- Printer Features
- Scanner Features
- Facsimile Features
- Extended Feature Settings
- Program (Document Server)
- Program (Copier)
- Program (Scanner)
- Web Image Monitor Setting
- Web Service Settings
- System Settings

### 3.14.3 DATA THAT CANNOT BE IMPORTED OR EXPORTED:

- Address book
  - Programs (fax function)
  - Programs (printer function)
  - Scanner function programs that include password settings
  - User stamp in the copy default settings
  - Settings for configuring from telnet
  - @Remote-related data
  - Counters
  - EFI printer unit settings (At the time of EFI printer unit connection)
  - Settings that can be specified using Web Image Monitor or Web Service only (such as Bonjour or SSDP settings)
  - Some System Settings\*1 \*2
- \*1 The setting for the date, those settings that require the device certificate, and those settings that need to be adjusted for each device (for example, image adjustment settings) cannot be imported or exported.
- \*2 Settings only for executing functions and settings only for viewing cannot be imported or exported.

### 3.14.4 IMPORT/EXPORT CONDITION:

Import/export is possible between devices only if their models, region of use, and the following device configuration match.

- Input Tray
- Output Tray
- Whether or not equipped with the duplex function
- Whether or not equipped with a finisher and the type of finisher
- ADF
- Whether or not equipped with a hard disk
- Whether or not equipped with the Remote Machine function

#### ***Location of stored data (log):***

- The log is stored in the same location as the exported device setting information file.
- To use this function, it is necessary to create the device setting information file with special software and store it on the web server. For details, contact your sales representative.

**Possible solutions for import/export problems:**

If an error occurs, check the log's result code first. Values other than 0 indicate that an error occurred.

The result code will appear in the circled area illustrated below.

- Example of a log file

```
*1.0.0*
*ExecType, *Date, *SerialNo, PnP*, *Model*, *Destinaion*, *IP*, *Host*, *Storage*, *FileNam
e*, *FileID*, *TotalItem*, *NumOfOkItem*, *ResultCode*, *ResultName*, *Identifier*
*IMPORT*
*2012-07-05T15:29:16+09:00*
*3C35-7M0014*
*Brand Name*
*Product Name*
*0*
*10*
*10.250.155.125*
*RNP00267332582D*
*SD*
*201207051519563C35-710220.csv*
*201207051519563C35-710220*
* 0*
* 2*
**..ID REQUEST*
*TargetID*, *ModuleID*, *PrefID*, *Item*, *NgCode*, *NgName*
```

Appendix:  
Service  
Program  
Mode Tables

If you cannot solve the problem or do not know how to solve it after checking the code, note down the error log entry, and then contact your service representative.

Result Code	Cause	Solutions
<b>2</b> <b>(INVALID REQUEST)</b>	A file import was attempted between different models or machines with different device configurations.	Import files exported from the same model with the same device configurations.
<b>4</b> <b>(INVALID OUTPUT DIR)</b>	Failed to write the device information to the destination device.	Check whether the destination device is operating normally.
<b>7</b> <b>(MODULE ERROR)</b>	An unexpected error occurred during import or export.	Switch the power off and then back on, and then try the operation again. If the error persists, contact your service representative.
<b>8</b> <b>(DISK FULL)</b>	The available storage space on the external medium is insufficient.	Execute the operation again after making sure there is enough storage space.
<b>9</b> <b>(DEVICE ERROR)</b>	Failed to write or read the log file.	Check whether the path to the folder for storing the file or the folder in which the file is stored is missing.
<b>10</b> <b>(LOG ERROR)</b>	The hard disk is faulty.	Contact your service representative.
<b>20</b> <b>(PART FAILED)</b>	Failed to import some settings.	The reason for the failure is logged in "NgCode". Check the code. ◆ Reason for the Error (Ng-Name) 2. INVALID VALUE The specified value exceeds the allowable range. 3. PERMISSION ERROR The permission to edit the setting is missing. 4. NOT EXIST The setting does not exist in the system. 5. INTERLOCK ERROR The setting cannot be changed because of the system status or interlocking with other specified settings. 6. OTHER ERROR The setting cannot be changed for some other reason.
<b>21</b> <b>(INVALID FILE)</b>	Failed to import the file because it is in the wrong format in the external medium.	Check whether the file format is correct. The log is in the form of a CSV file
<b>22</b> <b>(INVALID KEY)</b>	The encryption key is not valid.	Use the correct encryption key.

**NOTE:**

- When exporting device information from the control panel, the data can be saved only on an SD card.
- The file format for exports is CSV.

### 3.14.5 EXPORTING DEVICE INFORMATION

When exporting SP device information from the control panel, the data is saved on an SD card.

1. Insert an SD card into the media slot on the side of the control panel.
2. Enter SP mode.
3. Press SP5749-001
4. Select target SP settings to be exported.

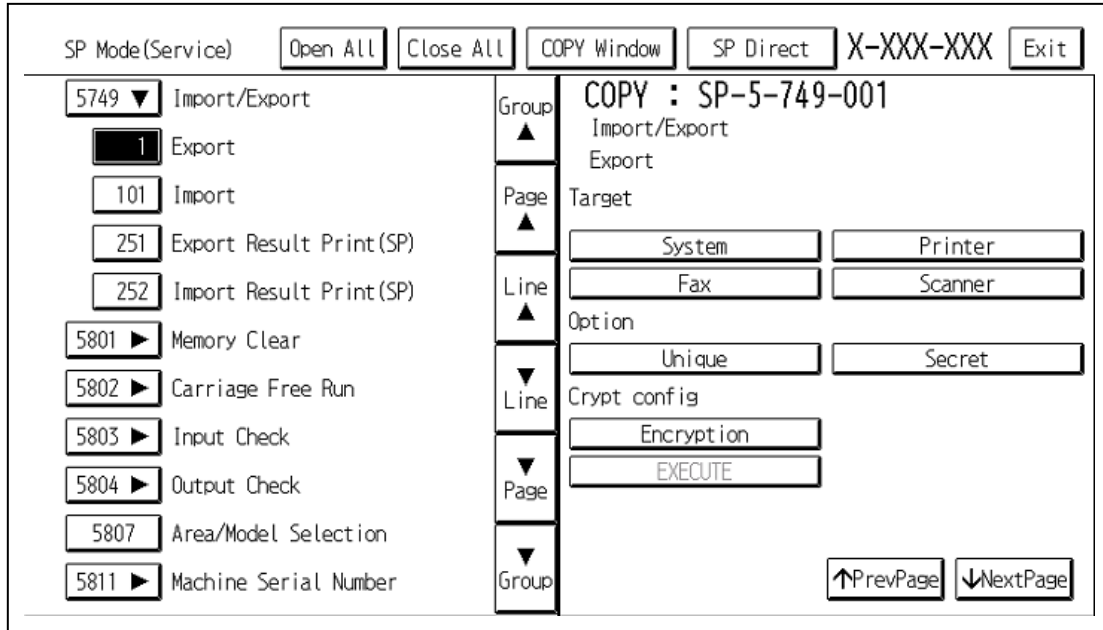

Appendix:  
Service  
Program  
Mode Tables

5. Select the option settings.

Item	Specification	Note
Unique	Information unique to the machine is included in the exported file if you have selected the "Unique" setting	<p>Information unique to the machine that can be updated:</p> <ol style="list-style-type: none"> <li>1. Items that are used to identify the machine among a group of multiple devices. Ex: IP address, host name, information associated with the FAX number, mail address assigned to the machine</li> <li>2. Items for specifying the options installed on the machine. Ex: Lot number for developer</li> </ol> <p>Information unique to the machine that cannot be updated:</p> <ol style="list-style-type: none"> <li>3. Items for which the problem may occur by importing Ex: Serial number, information related to @Remote</li> <li>4. Items for managing the history of the machine Ex: Time and date, counter information, installation date</li> <li>5. Engine settings</li> </ol>

Item	Specification	Note
<b>Secret</b>	Confidential information is exported if you select the "Secret" setting.	Confidential information: #1. Data that absolutely cannot be exported. (Asterisks ("*") are used to mask this information inside the exported file.) Ex: Password, encryption key, PIN code #2. Confidential information Ex: User name, user ID, department code, e-mail addresses, phone numbers #3. Personal information Example: Document name. image data #4. Sensitive information Ex: IP address, MAC address, Network parameters

## 6. Select an encryption setting.

<b>Encryption</b>	Select whether or not encryption will be performed when exporting.  If the "Encryption" key is pressed, you can export confidential information (in an encrypted state)	If the encryption function is used, the encryption key must be set through direct input  - Type an arbitrary password using the software keyboard - The password can be up to 32 characters in length
-------------------	---	--

7. Press "Execute".

8. Press [OK].

**NOTE:**

- If data export fails, the details of the error can be viewed in the log.

### 3.14.6 IMPORTING DEVICE INFORMATION

Import device information saved on an SD card.

1. Insert an SD card into the media slot on the side of the control panel.
2. Enter SP mode.
3. Press SP5749-101

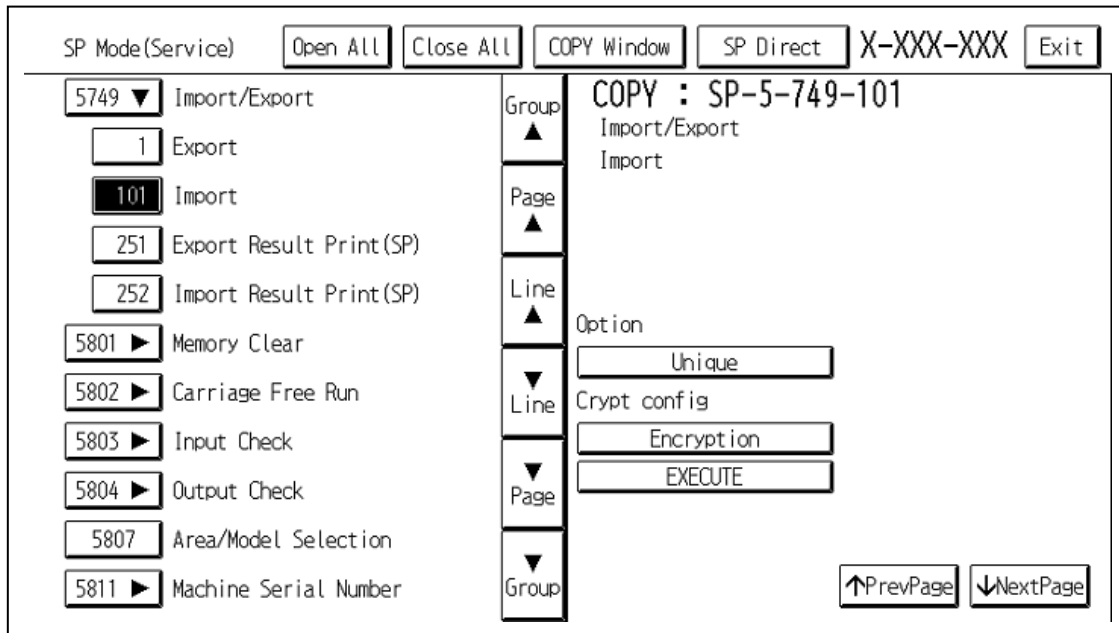

Appendix:  
Service  
Program  
Mode Tables

4. Select a unique setting.
5. Press “Encryption key”, if the encryption key was created when the file was exported.

<b>Unique</b>	To import unique information to the machine, press the “Unique” key.	Refer to the above information
<b>Encryption</b>	If the encrypted file is selected as the file to be imported, this setting is required.	

6. Press “Execute”.
7. Press [OK].

Note:

- If data export fails, the details of the error can be viewed in the log.

**SR790(B408)/SR3090(D588)**  
**1000-SHEET FINISHER**

<b>REVISION HISTORY</b>		
<b>Page</b>	<b>Date</b>	<b>Added/Updated/New</b>
		None



# 1000-SHEET FINISHER B408/D588

## TABLE OF CONTENTS

<b>1. REPLACEMENT AND ADJUSTMENT</b> .....	<b>1</b>
1.1 MAIN PCB .....	1
1.2 STAPLER UNIT .....	2
1.3 MOTORS.....	3
1.3.1 SHIFT MOTOR.....	3
1.3.2 STAPLER MOTOR.....	3
1.3.3 UPPER TRANSPORT MOTOR AND EXIT MOTOR .....	4
1.3.4 LOWER TRANSPORT MOTOR .....	4
1.4 MOTORS AND SENSORS.....	5
1.4.1 PREPARATION.....	5
1.4.2 STACK HEIGHT SENSOR .....	6
1.4.3 STAPLER TRAY PAPER SENSOR.....	6
1.4.4 LOWER TRAY LIFT MOTOR .....	7
1.4.5 STACK FEED-OUT MOTOR .....	7
<b>2. TROUBLESHOOTING</b> .....	<b>8</b>
2.1 JAM DETECTION.....	8
<b>3. SERVICE TABLES</b> .....	<b>9</b>
3.1 DIP SWITCH SETTINGS .....	9
<b>4. DETAILED DESCRIPTIONS</b> .....	<b>10</b>
4.1 GENERAL LAYOUT .....	10
4.2 ELECTRICAL COMPONENT LAYOUT.....	11
4.3 ELECTRICAL COMPONENT DESCRIPTION.....	13
4.4 DRIVE LAYOUT .....	15
4.5 JUNCTION GATES .....	16
Upper Tray Mode.....	16
Sort/Stack Mode .....	16
Staple Mode.....	16
4.6 UPPER TRAY.....	17
4.7 LOWER TRAY UP/DOWN MECHANISMS .....	18
4.8 PAPER SHIFT MECHANISM .....	19
4.9 JOGGER UNIT PAPER POSITIONING MECHANISM.....	20
4.10 EXIT GUIDE PLATE.....	21
4.11 STAPLER MECHANISM .....	22
4.12 STAPLER UNIT MOVEMENT MECHANISM .....	23
4.13 PAPER FEED-OUT MECHANISM .....	24







# 1. REPLACEMENT AND ADJUSTMENT

## ⚠ CAUTION



Turn off the main power switch and unplug the machine before beginning any of the procedures in this section.

**NOTE:** This manual uses the following symbols.

 : See or Refer to    
  : Screws    
  : Connector    
  : Clip ring  
 : E-ring

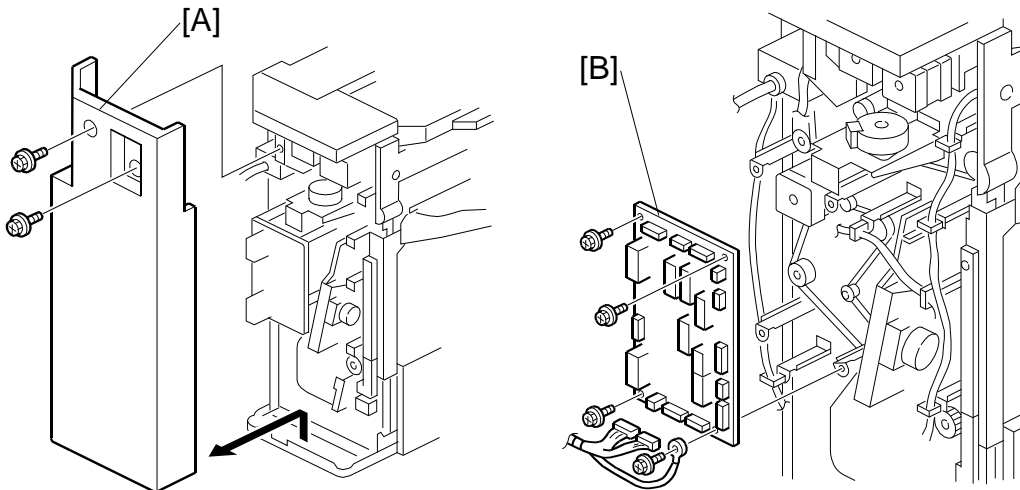
## 1.1 MAIN PCB



1. Rear cover [A] ( x 2)
2. Main PCB [B] ( x 4, All )

1000-Sheet  
Finisher  
SR790/SR3090  
B408/D588

## STAPLER UNIT

### 1.2 STAPLER UNIT

1. Side cover [A] (🔩 x 2)
2. Open exit guide plate [B]
3. Upper side cover [C] (🔩 x 2)

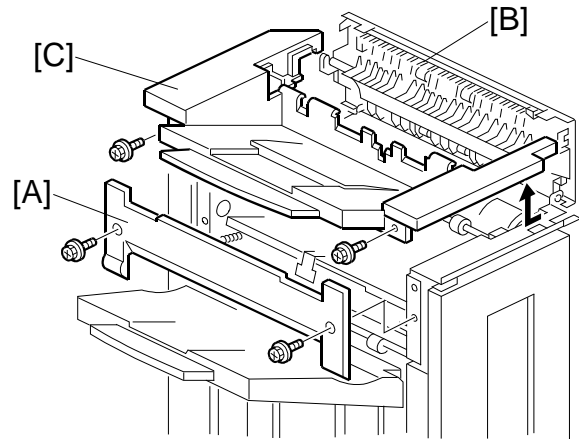

4. Front cover support plate [D] (🔩 x 1)
5. Front cover [E]
6. Front inner cover [F] (🔩 x 2)

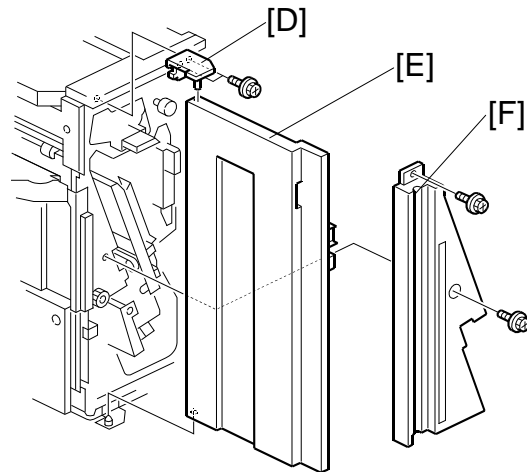

7. Harness [G]
8. Unhook the spring [H]
9. Turn the stapler unit [I] and take it out.
10. Bracket [J] (🔩 x 2)

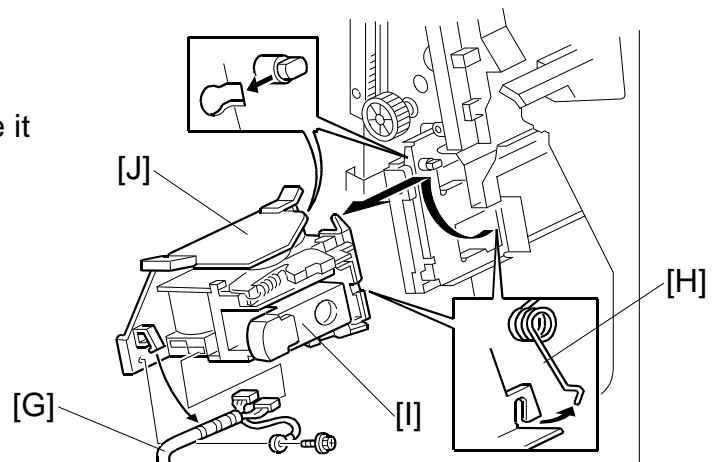

## 1.3 MOTORS

### 1.3.1 SHIFT MOTOR

1. Rear cover (☛1.1)
2. Shift motor [A] (🔩 x 2, 📡 x 1)

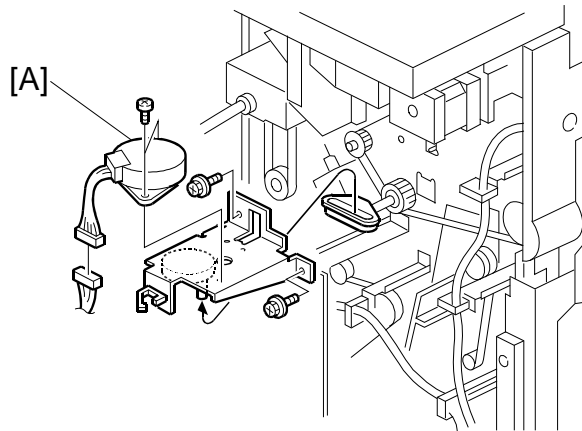

### 1.3.2 STAPLER MOTOR

1. Rear cover (☛1.1)
2. Stapler motor [A] (🔩 x 2, 📡 x 1)

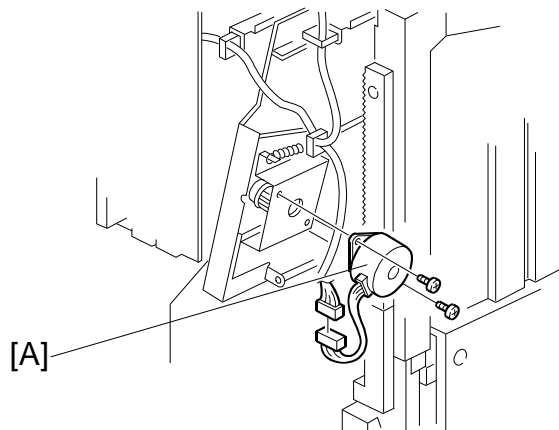

1000-Sheet  
Finisher  
SR790/SR3090  
B408/D588

## MOTORS

### 1.3.3 UPPER TRANSPORT MOTOR AND EXIT MOTOR

1. Rear cover (☛1.1)
2. Motor assembly [A] (🔩 x 4, 📏 x 2)
3. Upper transport motor [B] (🔩 x 4)
4. Exit motor [C] (🔩 x 4)

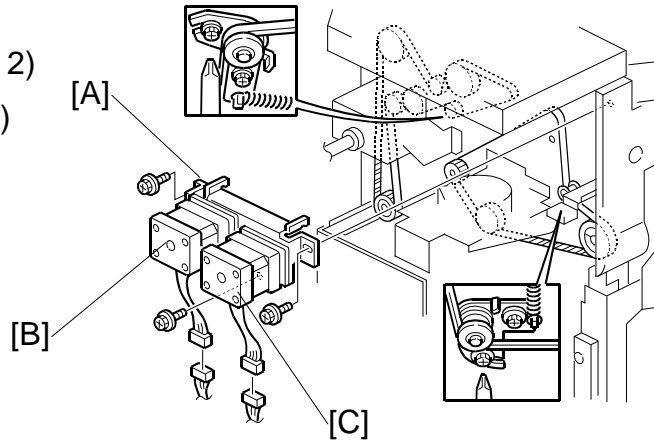

### 1.3.4 LOWER TRANSPORT MOTOR

1. Main PCB (☛1.1)
2. Lower transport motor [A] (🔩 x 2, 📏 x 1)

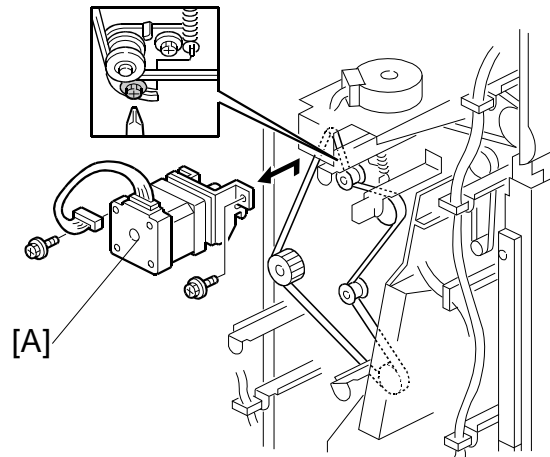

# 1.4 MOTORS AND SENSORS

## 1.4.1 PREPARATION

- 1. Front cover and inner cover (☛1.2)
- 2. Upper side cover [A] (🔩 x 2)
- 3. Upper tray [B] (🔩 x 1)

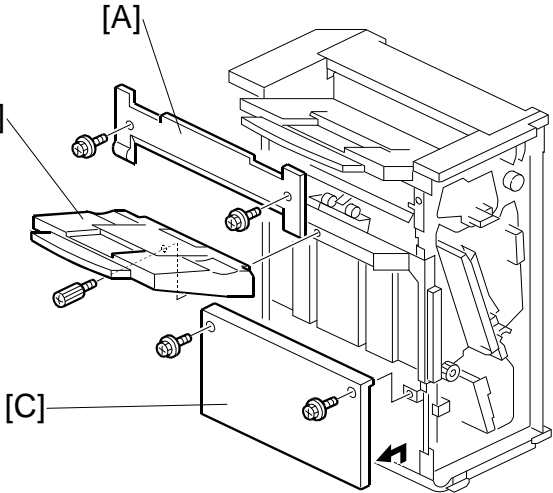

- 4. Lower side cover [C] (🔩 x 2)
- 5. Loosen the 2 screws [D].
- 6. Lower the lower tray guide plate [E].

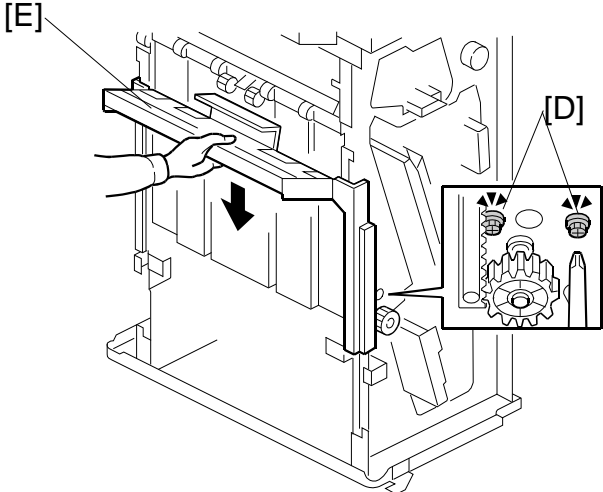

- 7. Guide plate [F] (🔩 x 4)

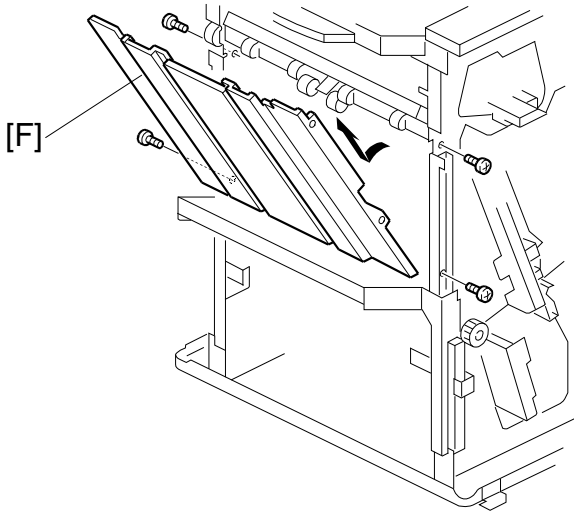

1000-Sheet  
Finisher  
SR790/SR3090  
B408/D588

### 1.4.2 STACK HEIGHT SENSOR

1. Stack height sensor assembly [A] (🔩 x 1)
2. Stack height sensor [B] (🔌 x 1)

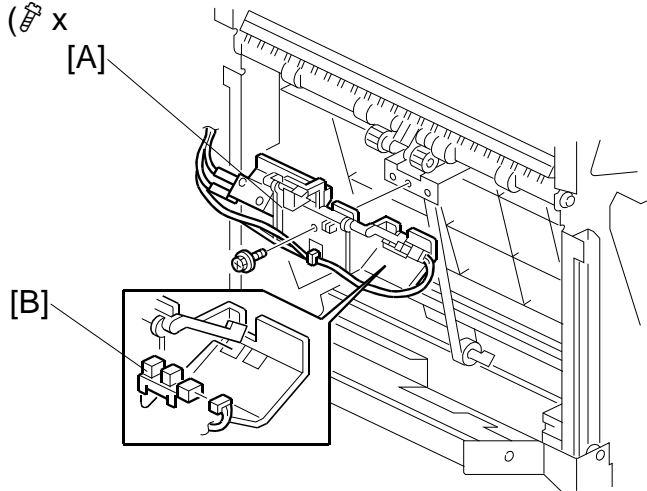

### 1.4.3 STAPLER TRAY PAPER SENSOR

1. Stapler tray paper sensor [A] (🔌 x 1)

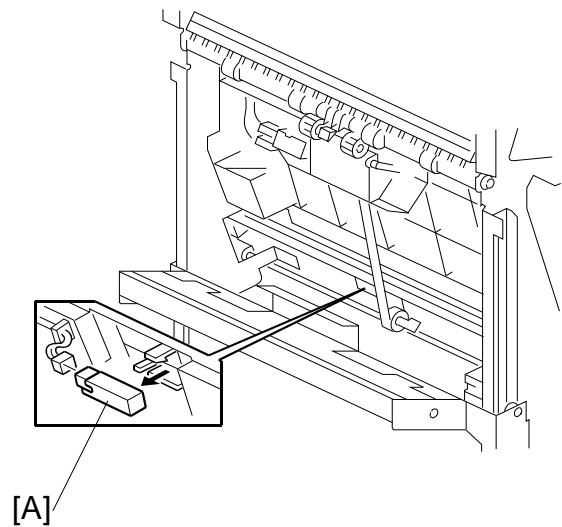



### 1.4.4 LOWER TRAY LIFT MOTOR

- 1. Lower tray lift motor [A] (⚙️ x 2, 📡 x 1)

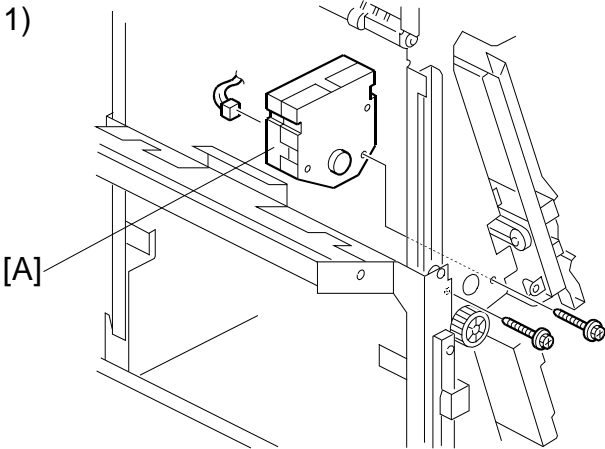

### 1.4.5 STACK FEED-OUT MOTOR

- 1. Stack feed-out motor [A] (⚙️ x 2, 📡 x 1)

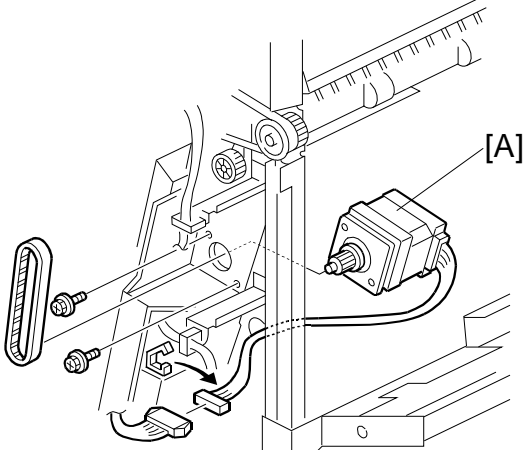

1000-Sheet  
Finisher  
SR790/SR3090  
B408/D588

## 2. TROUBLESHOOTING

### 2.1 JAM DETECTION

Mode		Jam	Content
Shift	Staple		
✓	✓	Entrance sensor: On check	The entrance sensor does not turn on within the normal time after the main machine exit sensor turns on
✓	✓	Entrance sensor: Off check	The entrance sensor does not turn off within the normal time after it turns on.
✓		Lower tray exit sensor: On check	The lower tray exit sensor does not turn on within the normal time after the entrance sensor turns off.
✓		Tray exit sensor: Off check	The tray exit sensor does not turn off within the normal time after it turns on.
	✓	Stapler tray entrance sensor: On check	The stapler tray entrance sensor does not switch on within the normal time after the entrance sensor switched on.
	✓	Stapler tray entrance sensor: Off check	The staple tray entrance sensor does not turn off within the normal time after it turns on.
	✓	Lower tray exit sensor: On check	The lower exit sensor does not turn on after the feed-out pawl feeds out the outputs.
	✓	Lower tray exit sensor: Off check	The lower exit sensor turns on when the feed-out pawl returns to its home position after feeding out the outputs.

---

## 3. SERVICE TABLES

### 3.1 DIP SWITCH SETTINGS

The DIP switches should not be set to any combination other than those listed in the table below.

SW100		Description
1	2	
0	0	Normal operation mode (Default)
1	0	Packing mode.

- Before packing the machine, do the following: Set switch 1 to 1 then back to zero. The lower tray moves to the lowest position. Then turn off the main switch.
- After unpacking the machine, do the following: After turning the main switch back on, the lower tray returns to home position automatically.

1000-Sheet  
Finisher  
SR790/SR3090  
B408/D588

---

## 4. DETAILED DESCRIPTIONS

### 4.1 GENERAL LAYOUT

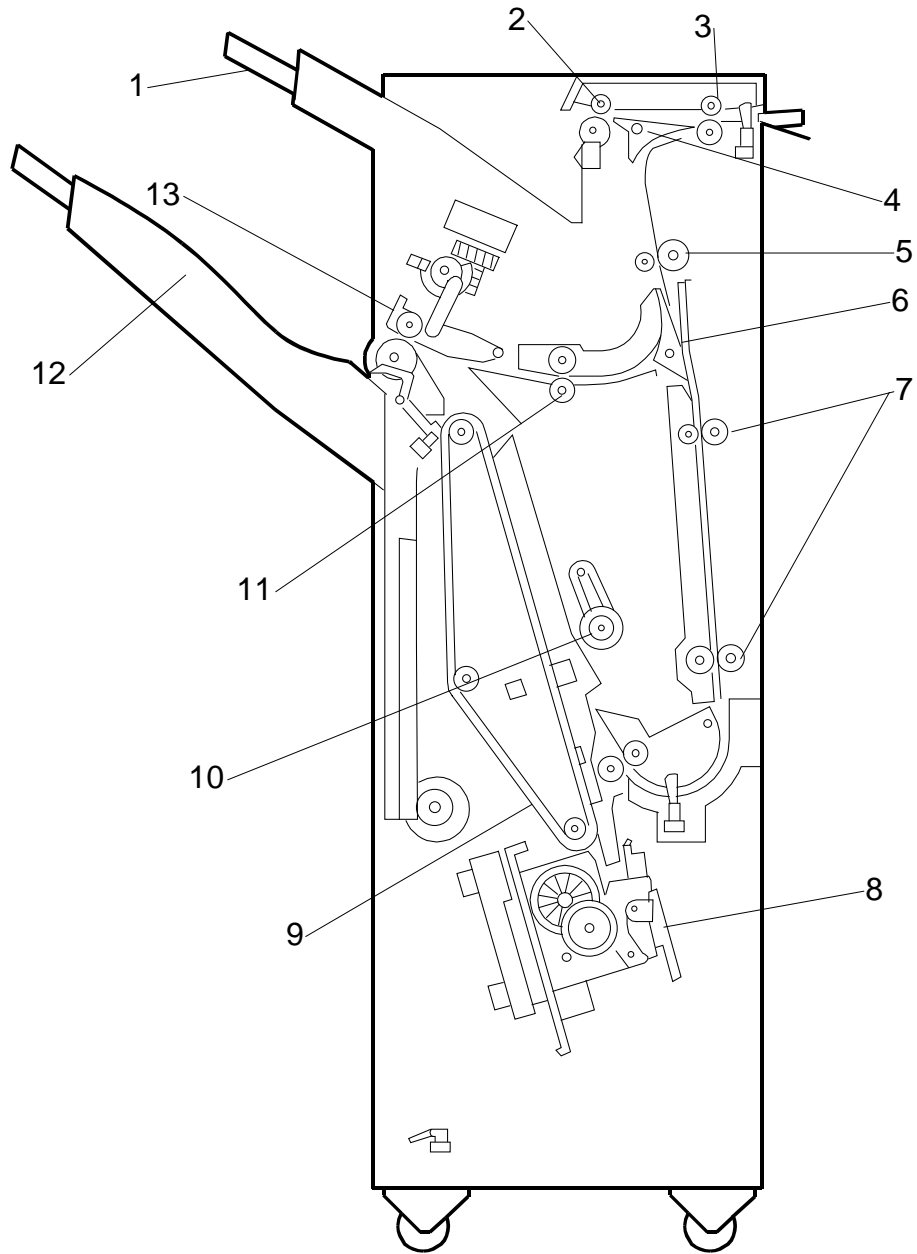

- |                            |                            |
|----------------------------|----------------------------|
| 1. Upper Tray              | 8. Stapler                 |
| 2. Upper Tray Exit Roller  | 9. Stack Feed-out Belt     |
| 3. Entrance Roller         | 10. Positioning Roller     |
| 4. Tray Junction Gate      | 11. Shift Roller           |
| 5. Upper Transport Roller  | 12. Lower Tray             |
| 6. Stapler Junction Gate   | 13. Lower Tray Exit Roller |
| 7. Lower Transport Rollers |                            |

## 4.2 ELECTRICAL COMPONENT LAYOUT

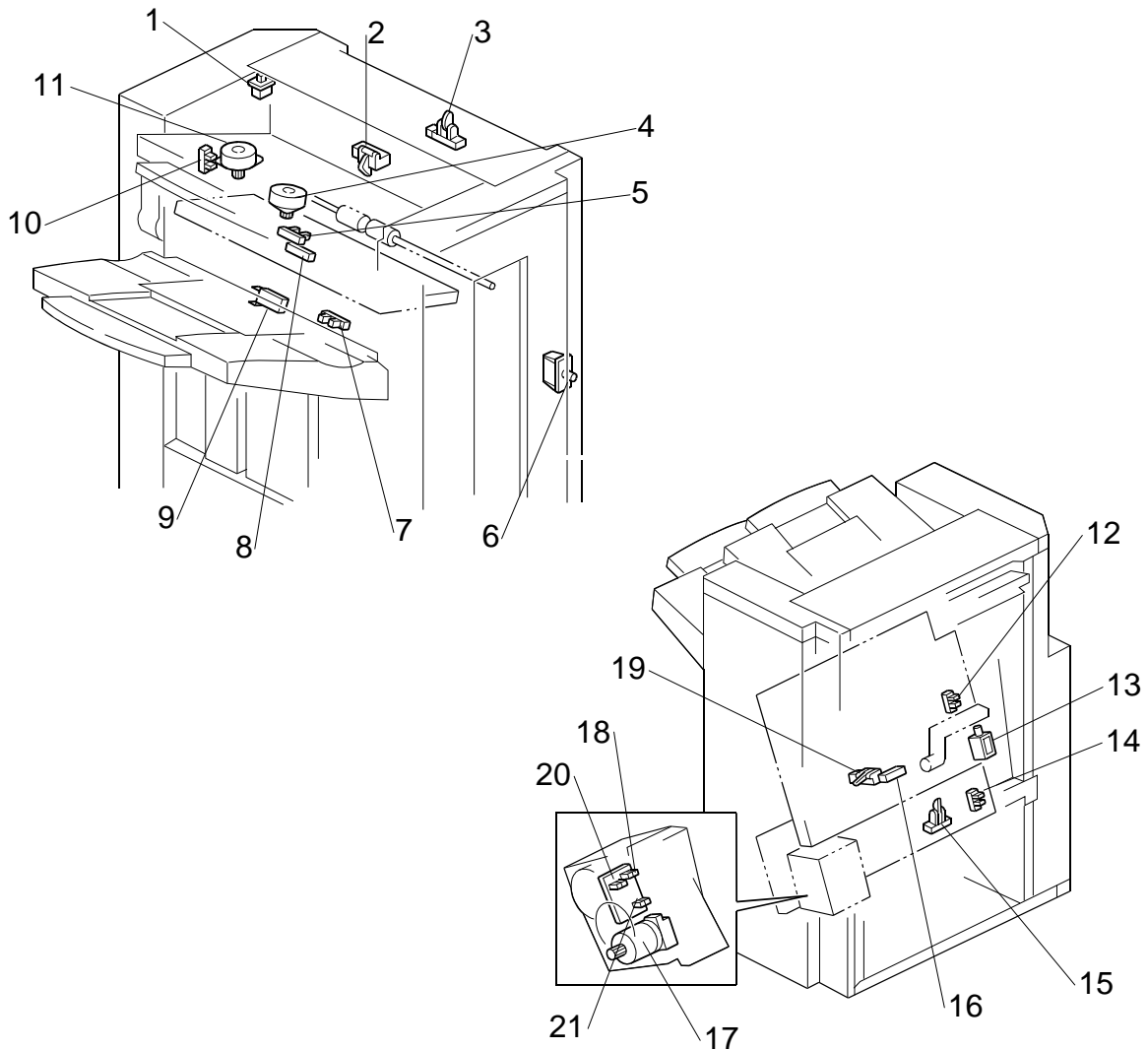

1000-Sheet  
Finisher  
SR790/SR3090  
B408/D588

- |                                  |                                   |
|----------------------------------|-----------------------------------|
| 1. Upper Cover Switch            | 12. Jogger Fence HP Sensor        |
| 2. Paper Limit Sensor            | 13. Positioning Roller Solenoid   |
| 3. Entrance Sensor               | 14. Stapler HP Sensor             |
| 4. Exit Guide Plate Motor        | 15. Stapler Tray Entrance Sensor  |
| 5. Exit Guide Plate HP Sensor    | 16. Stapler Tray Paper Sensor     |
| 6. Front Door Safety Switch      | 17. Stapler Hammer Motor          |
| 7. Stack Height Sensor           | 18. Staple Sheet Sensor           |
| 8. Lower Tray Exit Sensor        | 19. Stack Feed-out Belt HP Sensor |
| 9. Lower Tray Upper Limit Switch | 20. Stapler Rotation HP Sensor    |
| 10. Shift HP Sensor              | 21. Staple Sensor                 |
| 11. Shift Motor                  |                                   |

## ELECTRICAL COMPONENT LAYOUT

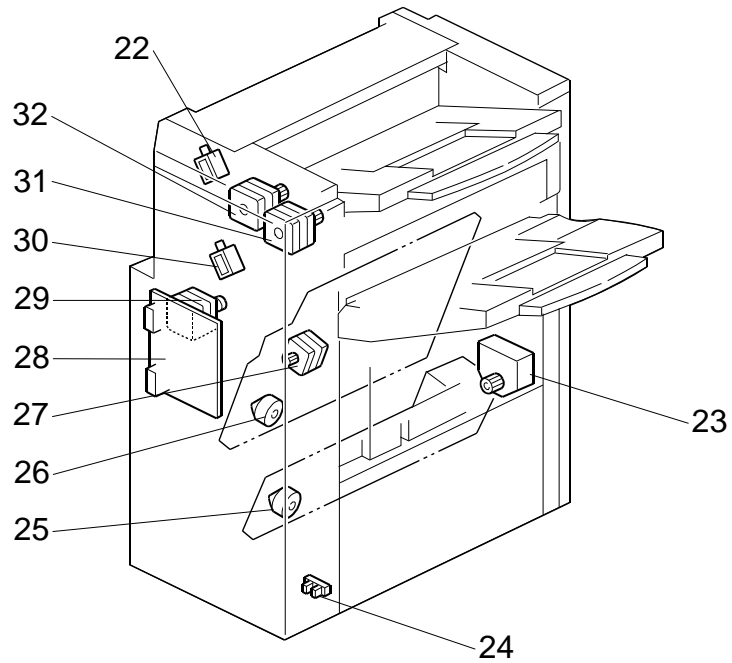

- 22. Tray Junction Gate Solenoid
- 23. Lower Tray Lift Motor
- 24. Lower Tray Lower Limit Sensor
- 25. Stapler Motor
- 26. Jogger Fence Motor
- 27. Stack Feed-out Motor
- 28. Main Board
- 29. Lower Transport Motor
- 30. Stapler Junction Gate Solenoid
- 31. Exit Motor
- 32. Upper Transport Motor

### 4.3 ELECTRICAL COMPONENT DESCRIPTION

Symbol	Name	Function	Index No.
<b>Motors</b>			
M1	Upper Transport	Drives the entrance roller and upper transport rollers.	32
M2	Lower Transport	Drives the lower transport rollers and the positioning roller.	29
M3	Jogger Fence	Drives the jogger fences.	26
M4	Staple Hammer	Drives the staple hammer.	17
M5	Stack Feed-out	Drives the stack feed-out belt.	27
M6	Exit Guide Plate	Opens and closes the exit guide plate.	4
M7	Exit	Drives the exit roller.	31
M8	Lower Tray Lift	Moves the lower tray up or down.	23
M9	Shift	Moves the shift roller from side to side.	11
M10	Stapler	Moves the stapler unit from side to side.	25
<b>Sensors</b>			
S1	Entrance	Detects copy paper entering the finisher and checks for misfeeds.	3
S2	Paper Limit	Detects when the paper stack height in the upper tray is at its limit.	2
S3	Jogger Fence HP	Detects when the jogger fence is at home position.	12
S4	Shift HP	Detects when the shift roller is at home position.	10
S5	Stack Feed-out Belt HP	Detects when the stack feed-out belt is at home position.	19
S6	Stapler HP	Detects when the stapler is at home position.	14
S7	Exit Guide Plate HP	Detects when the exit guide plate is at home position.	5
S8	Stapler Tray Entrance	Detects copy paper entering the stapler tray and checks for misfeeds.	15
S9	Lower Tray Exit	Checks for misfeeds.	8
S10	Stack Height	Detects the top of the copy paper stack.	7
S11	Lower Tray Lower Limit	Detects when the lower tray is at its lower limit position.	24
S12	Stapler Tray Paper	Detects when there is copy paper in the stapler tray.	16
S13	Staple Sheet	Detects the leading edge of the staple sheet.	18
S14	Stapler Rotation HP	Detects when the staple hammer is at home position.	20
S15	Staple	Detects whether there are staples in the staple cartridge.	21
<b>Solenoids</b>			
SOL1	Tray Junction Gate	Drives the tray junction gate.	22
SOL2	Stapler Junction Gate	Drives the stapler junction gate.	30

1000-Sheet  
Finisher  
SR790/SR3090  
B408/D588

## ELECTRICAL COMPONENT DESCRIPTION

<b>Symbol</b>	<b>Name</b>	<b>Function</b>	<b>Index No.</b>
SOL3	Positioning Roller	Moves the positioning roller.	13
<b>Switches</b>			
SW1	Lower Tray Upper Limit	Detects when the lower tray is at its upper limit position.	9
SW2	Front Door Safety	Cuts the dc power when the front door is opened.	6
SW3	Upper Cover	Cuts the dc power when the upper cover is opened.	1
<b>PCBs</b>			
PCB1	Main	Controls the finisher and communicates with the copier/printer.	28



## 4.4 DRIVE LAYOUT

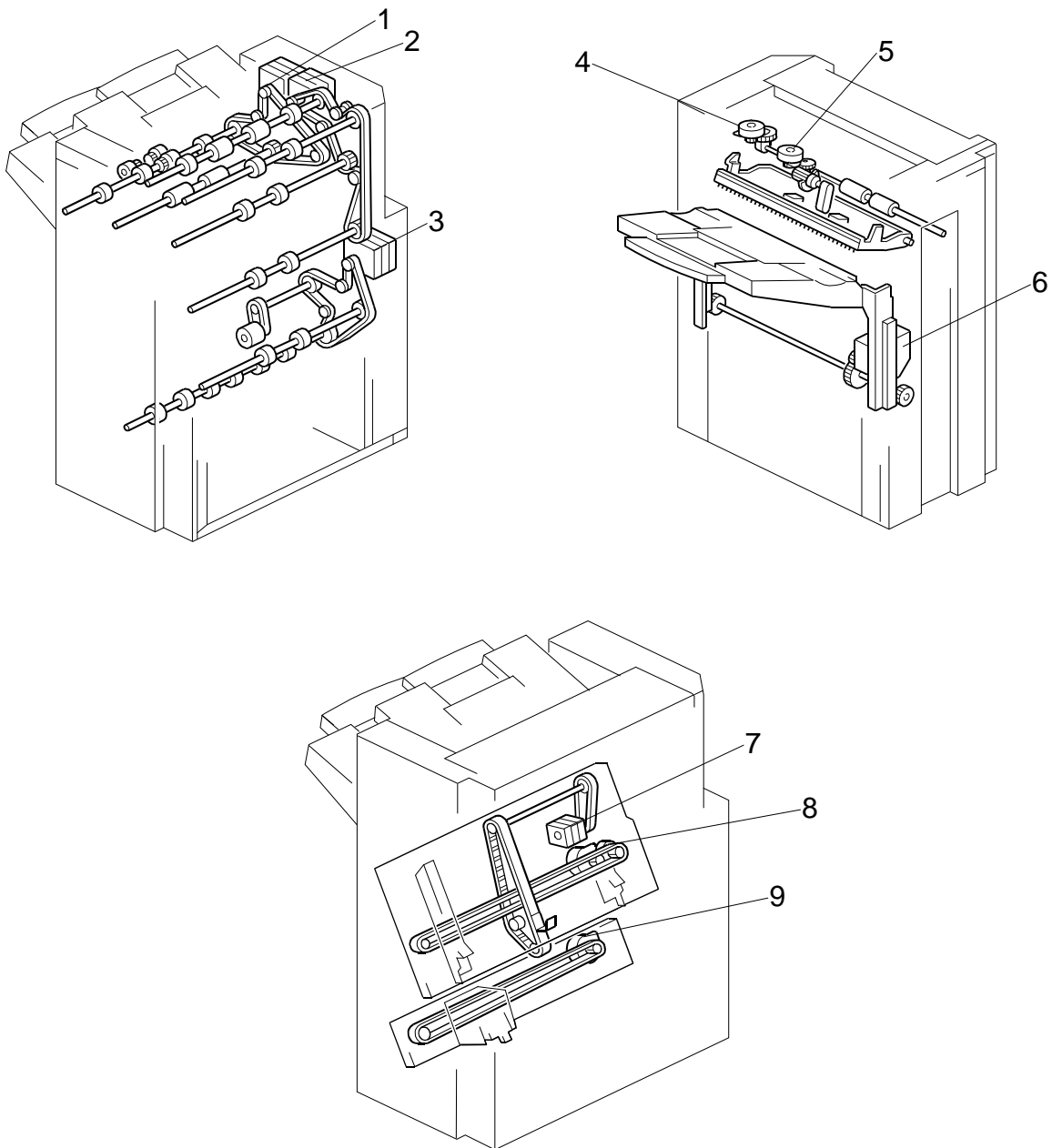

- |                           |                          |
|---------------------------|--------------------------|
| 1. Exit Motor             | 6. Lower Tray Lift Motor |
| 2. Upper Transport Motor  | 7. Stack Feed-out Motor  |
| 3. Lower Transport Motor  | 8. Jogger Motor          |
| 4. Shift Motor            | 9. Stapler Motor         |
| 5. Exit Guide Plate Motor |                          |

1000-Sheet  
Finisher  
SR790/SR3090  
B408/D588

## 4.5 JUNCTION GATES

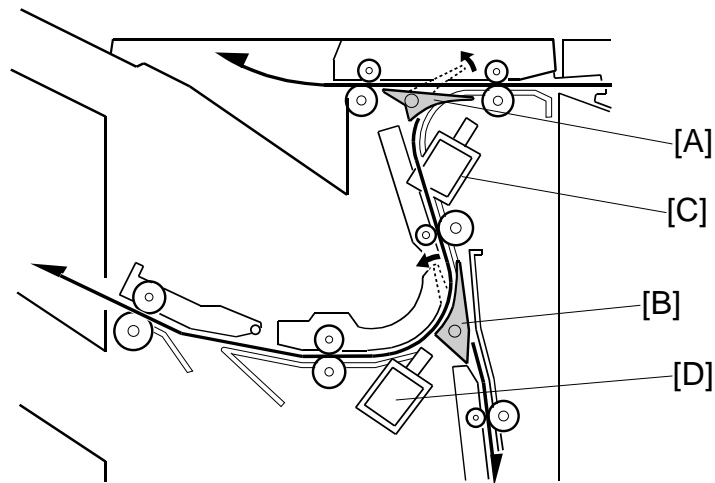

Depending on the finishing mode, the copies are directed up, straight through, or down by the combination of the tray junction gate [A] and stapler junction gate [B]. These gates are controlled by the tray junction gate solenoid [C] and stapler junction gate solenoid [D].

### ***Upper Tray Mode***

The tray junction gate solenoid remains off. The copies go up to the upper tray.

### ***Sort/Stack Mode***

The tray junction gate solenoid turns on and the stapler junction gate solenoid remains off. The copies are sent to the lower tray directly.

### ***Staple Mode***

The tray junction gate solenoid and the stapler junction gate solenoid both turn on. The copies go down to the jogger unit.

## 4.6 UPPER TRAY

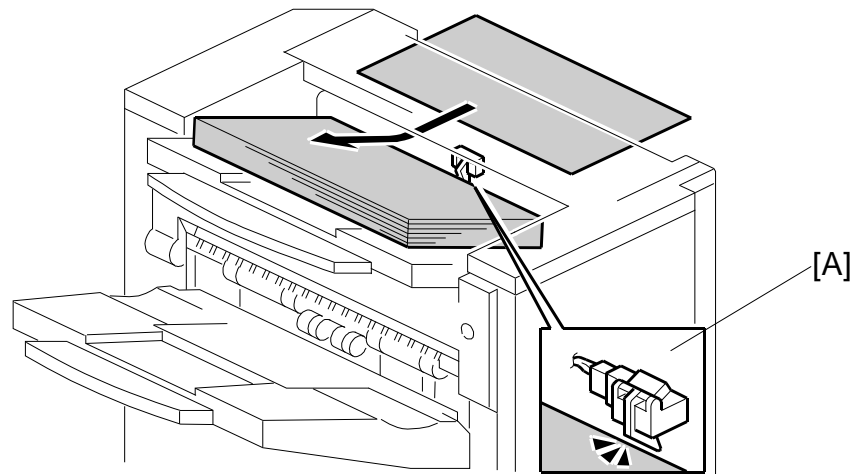

When the paper limit sensor [A] switches on during feed-out for each of three consecutive sheets of paper, paper overflow is detected.

1000-Sheet  
Finisher  
SR790/SR3090  
B408/D588

## 4.7 LOWER TRAY UP/DOWN MECHANISMS

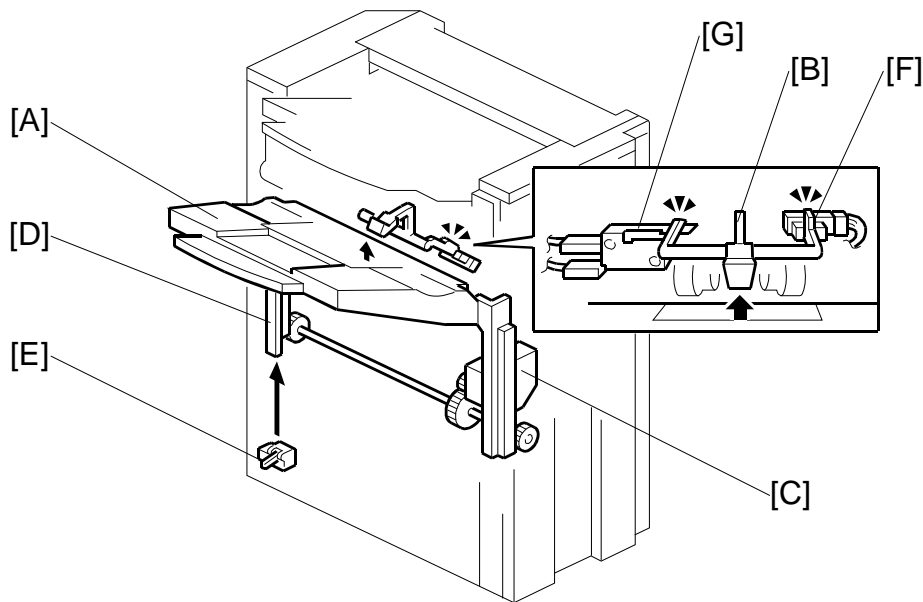

The vertical position of the lower tray [A] depends on the height of the copied paper stack on the lower tray. The stack height sensor feeler [B] contacts the top of the stack, and the lower tray lift motor [C] controls the tray height.

When the lower tray reaches its lowest possible position, the actuator [D] turns on the lower tray lower limit sensor [E], and copying stops.

### ***Tray Up***

When the copy paper on the tray is removed, the stack height sensor [F] turns off and the tray lifts up. Then, the tray stops when the sensor turns on again (the tray pushes up the feeler).

If the stack height sensor fails, the lower tray upper limit switch [G] detects the tray and stops the motor. This is a safety measure against stack height sensor failure.

### ***Sort/Stack Mode (Tray Down)***

Every five sheets of paper, the tray goes down until the sensor turns off again. Then, it goes up until the sensor is on again.

### ***Staple Mode (Tray Down)***

After a stapled copy is fed out, the tray goes up for 220 ms and stops for 300 ms. Then, it goes down for 1 second, waits for 500 ms, then goes up until the sensor turns on.

## 4.8 PAPER SHIFT MECHANISM

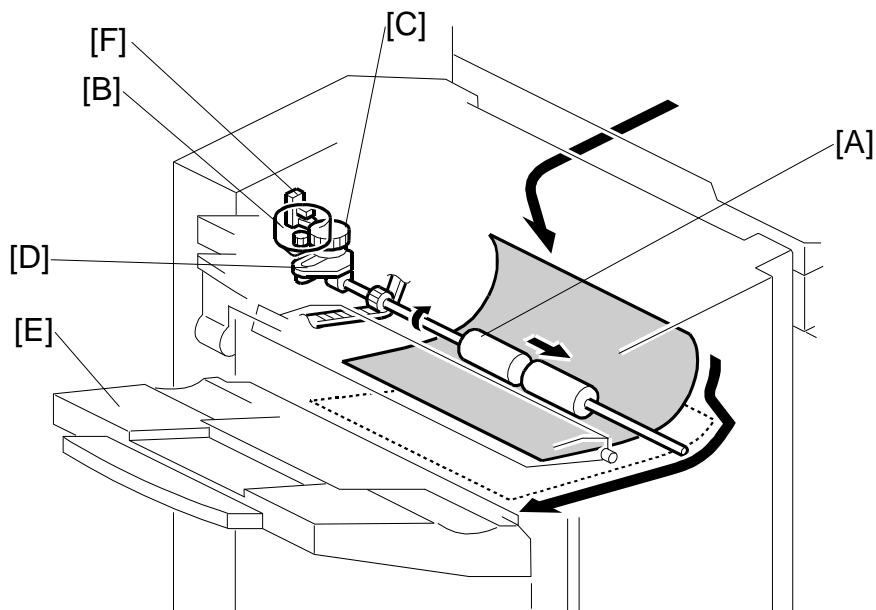

In the sort/stack mode, the shift roller [A] moves from side to side to separate the sets of copies.

The horizontal position of the shift roller is controlled by the shift motor [B] and the shift gear disk [C]. After the trailing edge of the copy passes the upper transport roller, the shift motor turns on, driving the shift gear disk and the link [D].

After the paper is delivered to the lower tray [E], the shift roller moves to its home position, which is detected by the shift HP sensor [F]. Then, when the trailing edge of the next copy passes the upper transport roller, the shift roller shifts again. This operation is done every sheet.

When the trailing edge of each page in the next set of copies passes the upper transport roller, the shift roller shifts in the opposite direction.

1000-Sheet  
Finisher  
SR790/SR3090  
B408/D588

## 4.9 JOGGER UNIT PAPER POSITIONING MECHANISM

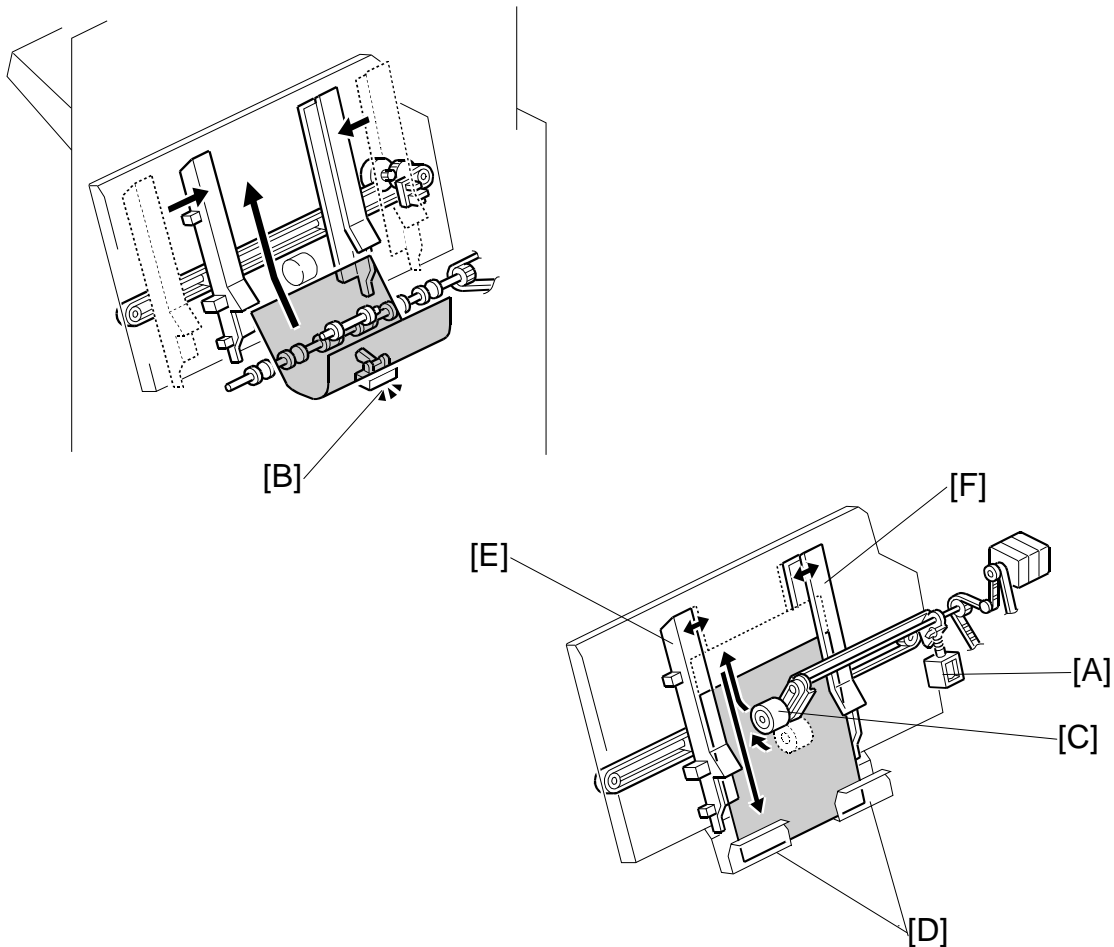

In staple mode, each sheet of copy paper is vertically and horizontally aligned when it arrives in the jogger unit.

For the vertical paper alignment, the positioning roller solenoid [A] turns on shortly after the stapler tray entrance sensor [B] turns off, and the positioning roller [C] pushes the copy against the bottom of the stack stopper [D].

For the horizontal paper alignment, the jogger front fence [E] and the rear fence [F] move to the waiting position, which is 18 mm away from the side of the paper. When aligning the paper vertically, the jogger fence moves in 14 mm from the waiting position. After the vertical position has been aligned, the jogger fence pushes the paper 4 mm against the rear fence to align the paper horizontally. Then the jogger fence moves back to the previous position.

## 4.10 EXIT GUIDE PLATE

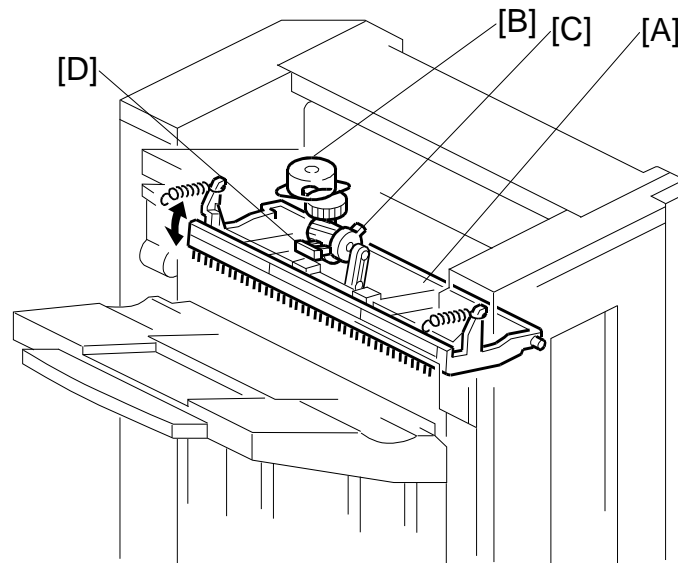

When stacking a large size of paper (such as A3, DLT) in the jogger unit, the leading edge of the paper reaches the exit rollers. To prevent the paper from running into the exit rollers and not being aligned correctly, the exit guide plate [A] is moved up to make a gap between the exit rollers. This operation is done for all paper sizes, but is only needed for the larger sizes.

The exit guide plate motor [B] and exit roller release cam [C] control the exit guide plate movement. When the exit guide plate motor starts, the cam turns and the exit guide plate moves up. When stapling is finished, the exit guide plate motor turns on again to close the exit guide plate. When the exit guide plate HP sensor [D] turns on, the motor stops.

1000-Sheet  
Finisher  
SR790/SR3090  
B408/D588

## 4.11 STAPLER MECHANISM

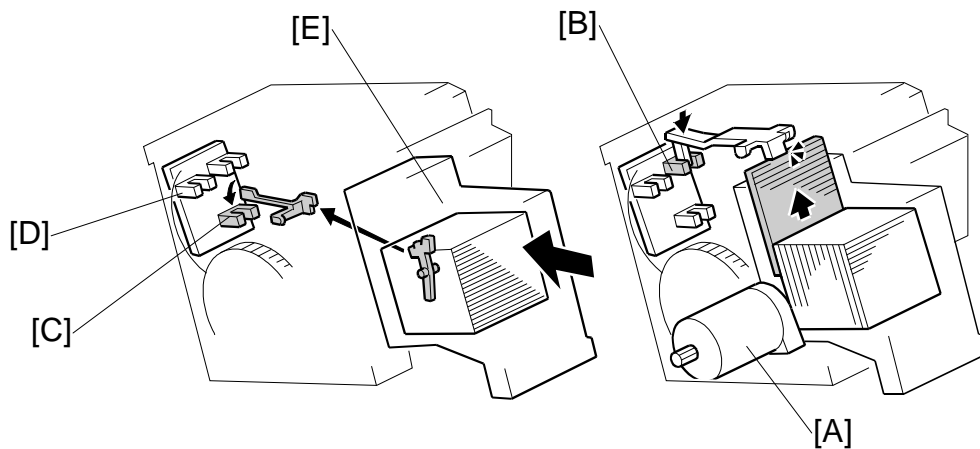

The staple hammer motor [A] drives the staple hammer.

The staple sheet sensor [B] detects the leading edge of the staple sheet at the stapling position to prevent the hammer from operating if there are no staples at the stapling position.

If there is no staple cartridge in the stapler unit or no staples in the staple cartridge, staple end is indicated on the operation panel. The stapler sensor [C] detects this.

The stapler rotation HP sensor [D] checks whether the staple hammer mechanism returns to home position after each stack has been stapled.

When excessive load is applied to the staple hammer motor, the copier detects a staple jam. When a staple jam has occurred, the jammed staple is inside the staple cartridge [E]. Therefore, the jammed staple can be removed easily after pulling out the staple cartridge.



## 4.12 STAPLER UNIT MOVEMENT MECHANISM

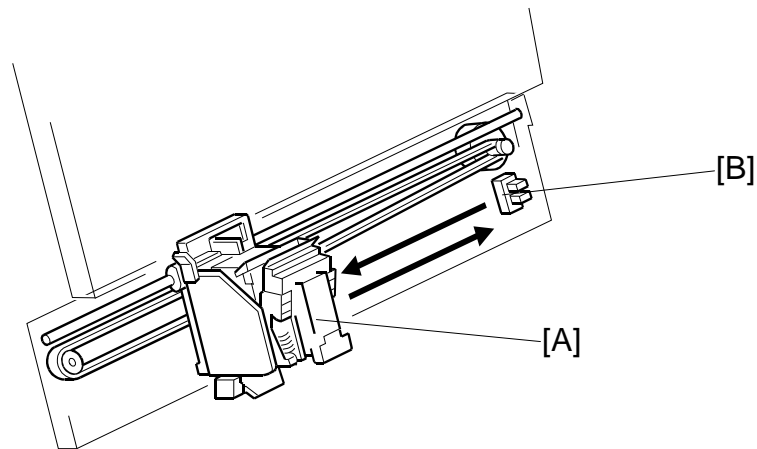

The stapler motor moves the stapler [A] from side to side. After the start key is pressed, the stapler moves from its home position to the stapling position.

If two-staple-position mode is selected, the stapler moves to the front stapling position first, then moves to the rear stapling position. However, for the next copy set, it staples in the reverse order (at the rear side first, then at the front side).

After the job is completed, the stapler moves back to its home position. The stapler HP sensor [B] detects this.

1000-Sheet  
Finisher  
SR790/SR3090  
B408/D588

## 4.13 PAPER FEED-OUT MECHANISM

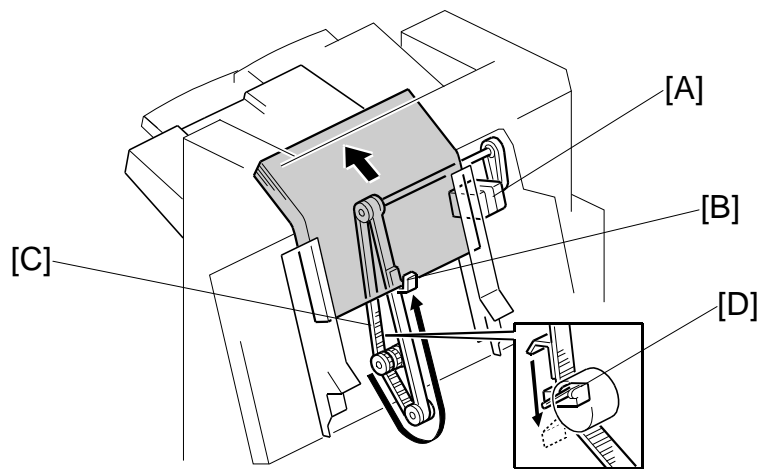

After the copies have been stapled, the stack feed-out motor [A] starts. The pawl [B] on the stack feed-out belt [C] transports the set of stapled copies up and feeds it to the shift roller. The shift roller takes over stack feed-out after the leading edge reaches this roller.

Just before the stapled stack passes through the lower tray exit sensor, the stack-feed-out motor turns off until the shift rollers have completely fed the stack out to the lower tray. Then, the stack-feed-out motor turns on again until the pawl [B] actuates the stack feed-out belt home position sensor [D].

**D386/D634**

**BRIDGE UNIT BU3030/BU3060**

<b>REVISION HISTORY</b>		
<b>Page</b>	<b>Date</b>	<b>Added/Updated/New</b>
		None



# **BRIDGE UNIT BU3030/BU3060 (D386/D634)**

## **TABLE OF CONTENTS**

<b>1. REPLACEMENT AND ADJUSTMENT.....</b>	<b>1</b>
1.1 BRIDGE UNIT CONTROL BOARD.....	1
1.2 BRIDGE UNIT DRIVE MOTOR.....	2
1.3 TRAY EXIT SENSOR .....	3
1.4 RELAY SENSOR .....	4
<b>2. DETAILS .....</b>	<b>5</b>
2.1 MECHANICAL COMPONENT LAYOUT .....	5
2.2 DRIVE LAYOUT.....	6
2.3 ELECTRICAL COMPONENT LAYOUT .....	7
2.4 ELECTRICAL COMPONENT DESCRIPTION .....	8
2.5 JUNCTION GATE MECHANISM .....	9



# READ THIS FIRST

## Safety and Symbols

### Replacement Procedure Safety

#### **CAUTION**

- Turn off the main power switch and unplug the machine before beginning any of the replacement procedures in this manual.

When taking apart the bridge unit, first take the unit out of the copier.

#### Symbols Used in this Manual

This manual uses the following symbols.

: See or Refer to

: Screws

: Connector

: Clip ring

: E-ring





# 1. REPLACEMENT AND ADJUSTMENT

## 1.1 BRIDGE UNIT CONTROL BOARD

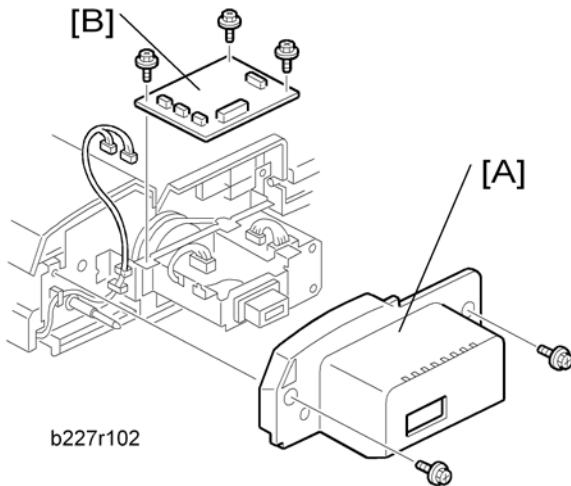

1. Bridge unit (➔ "Installation Procedure" in the base copier manual)
2. Rear cover [A] (🔩 x 2)
3. Bridge unit control board [B] (🔩 x 3, 🛠️ x 4)

## 1.2 BRIDGE UNIT DRIVE MOTOR

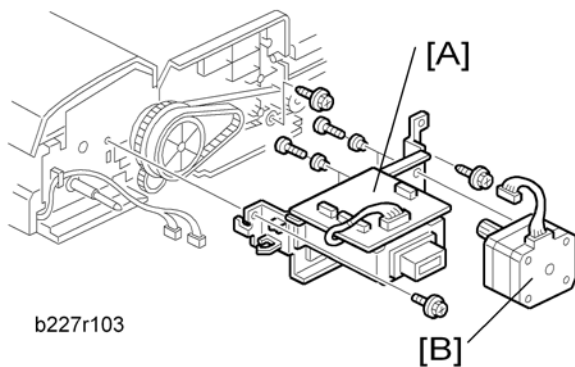

1. Bridge unit (➔ "Installation Procedure" in the base copier manual)
2. Rear cover (➔ "Bridge Unit Control Board")
3. Bracket [A] (⚙ x 3, ⚙ x 2)
4. Bridge unit drive motor [B] (⚙ x 4, ⚙ x 1)

## 1.3 TRAY EXIT SENSOR

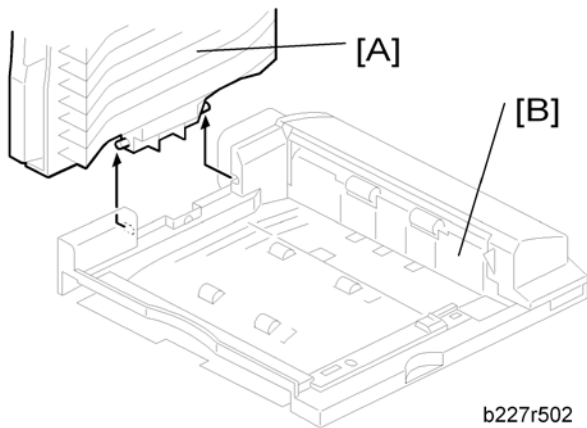

1. Bridge unit (➔ "Installation Procedure" in the base copier manual)
2. Rear cover (➔ "Bridge Unit Control Board")
3. Paper tray [A]
4. Exit guide [B] (🔧 x 1)

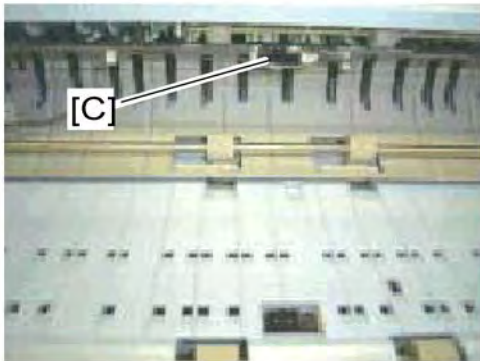

5. Tray exit sensor [C] (🔧 x 1)

## 1.4 RELAY SENSOR

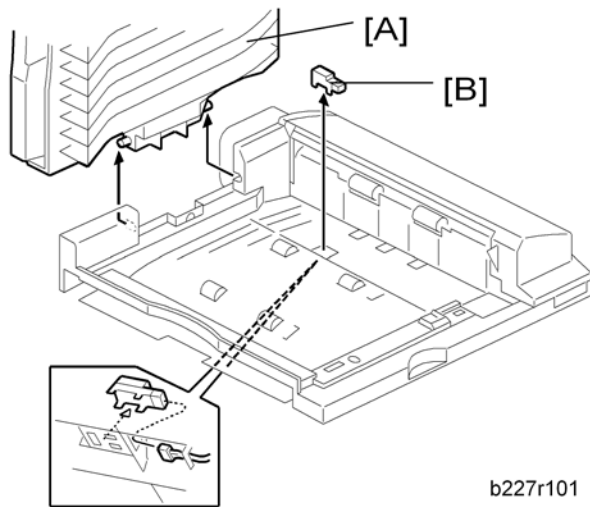

1. Bridge unit (➔ "Installation Procedure" in the base copier manual)
2. Paper tray [A]
3. Relay sensor [B] (☞ x 1)

## 2. DETAILS

### 2.1 MECHANICAL COMPONENT LAYOUT

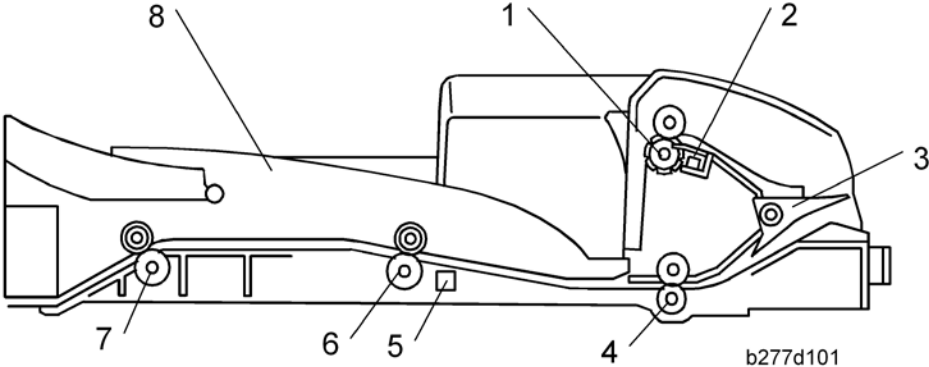

1. Upper Exit Roller	5. Relay Sensor
2. Tray Exit Sensor	6. 2nd Transport Roller
3. Junction Gate	7. Left Exit Roller
4. 1st Transport Roller	8. Paper Tray

Bridge Unit  
BU3030/  
BU3060  
(D386/D634)

## 2.2 DRIVE LAYOUT

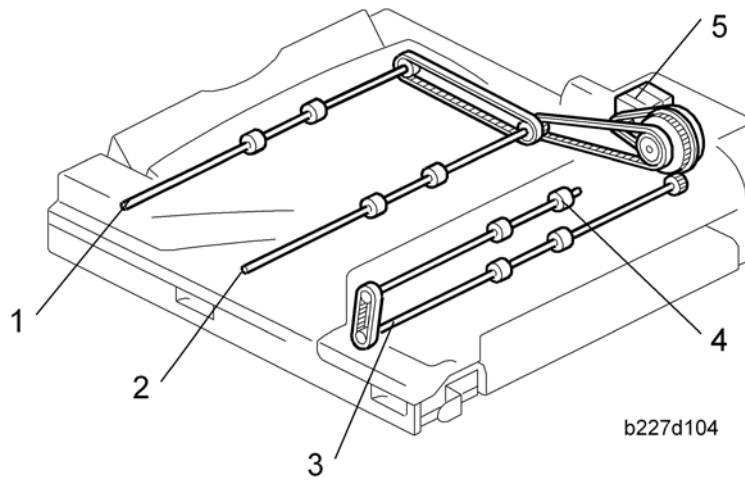

1. Left Exit Roller
2. 2nd Transport Roller
3. 1st Transport Roller
4. Upper Exit Roller
5. Bridge Unit Drive Motor

## 2.3 ELECTRICAL COMPONENT LAYOUT

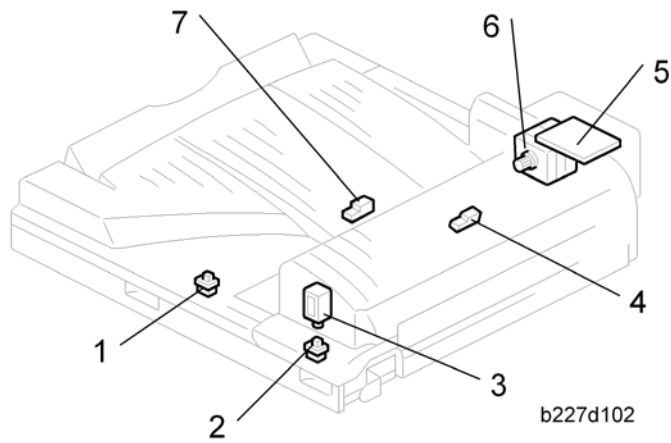

1. Left Guide Switch
2. Right Guide Switch
3. Junction Gate Solenoid
4. Tray Exit Sensor
5. Bridge Unit Control Board
6. Bridge Unit Drive Motor
7. Relay Sensor

## 2.4 ELECTRICAL COMPONENT DESCRIPTION

Symbol	Name	Function	Index No.
<b>Motors</b>			
M1	Drive Motor	Drives the bridge unit.	6
<b>Sensors</b>			
S1	Tray Exit	Checks for misfeeds.	4
S2	Relay	Checks for misfeeds.	7
<b>Switches</b>			
SW2	Right Guide	Detects when the right guide is opened.	2
SW3	Left Guide	Detects when the left guide is opened.	1
<b>Solenoids</b>			
SOL1	Junction Gate	Moves the junction gate to direct the paper to the upper tray (on top of the bridge unit) or to the finisher.	3
<b>PCBs</b>			
PCB1	Bridge Unit Control Board	Controls the bridge unit.	5



## 2.5 JUNCTION GATE MECHANISM

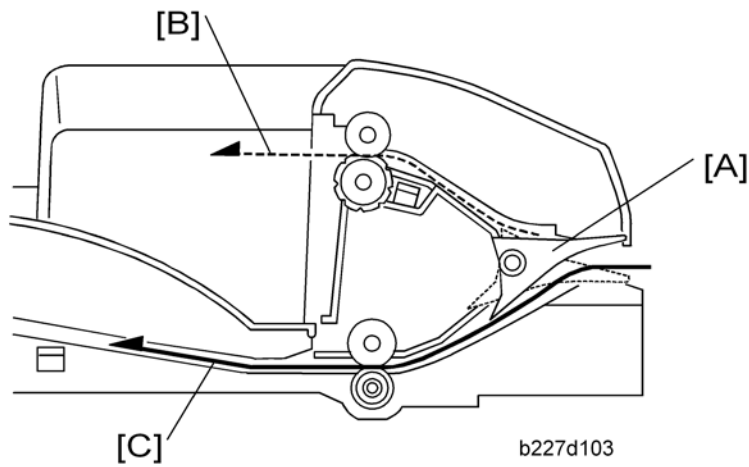

The junction gate [A] directs any paper reaching the bridge unit to either the upper tray (on top of the bridge unit) or to the finisher, depending on which has been selected.

If the junction gate solenoid has been activated, the junction gate [A] points downward and directs the paper to the upper tray [B] (dotted line path in illustration). When the solenoid is off, the junction gate points upward and the paper is fed out to the finisher [C] by the transport and left exit rollers (solid line).

# **PB3110(D537)/PB3130(D580)**

## **PAPER FEED UNIT**

<b>REVISION HISTORY</b>		
<b>Page</b>	<b>Date</b>	<b>Added/Updated/New</b>
		None



# PAPER FEED UNIT (D537/D580)

## TABLE OF CONTENTS

<b>1. REPLACEMENT AND ADJUSTMENT</b> .....	<b>1</b>
1.1 EXTERIOR COVER.....	1
1.1.1 REAR COVER.....	1
1.2 ELECTRICAL COMPONENTS.....	2
1.2.1 LIFT MOTORS.....	2
1.2.2 UPPER AND LOWER PAPER FEED CLUTCHES.....	3
1.2.3 PAPER FEED MOTOR.....	4
1.2.4 MAIN BOARD.....	4
1.3 FEED.....	5
1.3.1 PAPER FEED UNIT.....	5
1.3.2 PICK-UP, PAPER FEED AND SEPARATION ROLLERS.....	6
1.3.3 LIFT, PAPER END, AND RELAY SENSORS.....	7





---

# 1. REPLACEMENT AND ADJUSTMENT

## 1.1 EXTERIOR COVER

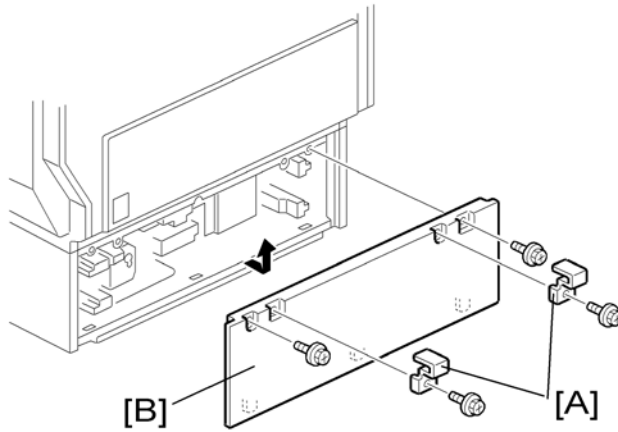
### 1.1.1 REAR COVER



1. Securing brackets [A] (  x 1 each)
2. Rear cover [B] (  x 2)

## 1.2 ELECTRICAL COMPONENTS

### 1.2.1 LIFT MOTORS

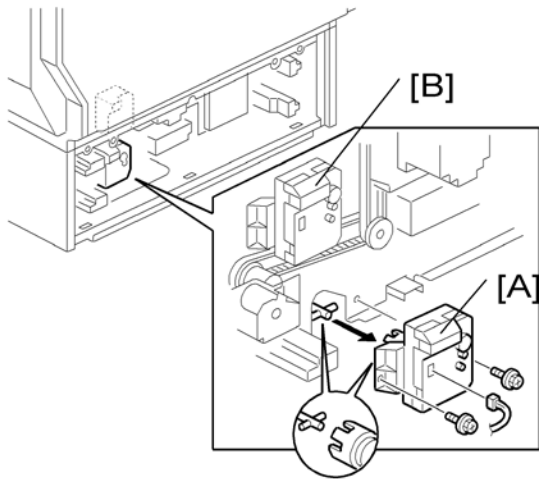

1. Rear cover (🔧 "Rear Cover")
2. Lift motors [A][B] (🔧 x 2, 📄 x 1 each)

## 1.2.2 UPPER AND LOWER PAPER FEED CLUTCHES

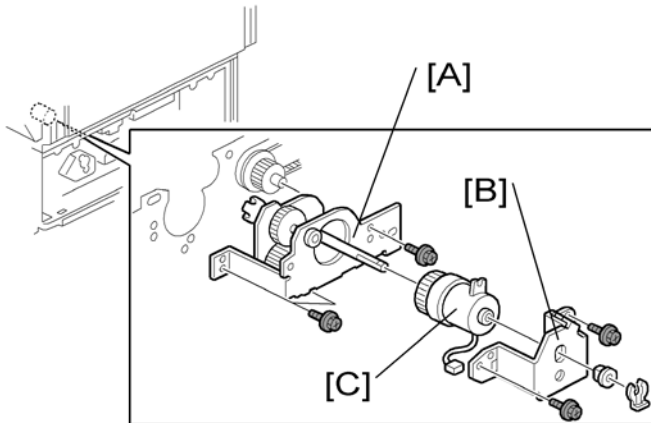

1. Rear cover (Rear Cover)
2. Upper paper feed gear unit [A] ( x 3, x 1)
3. Upper paper feed clutch bracket [B] ( x 1, x 2, bushing x 1)
4. Upper paper feed clutch [C]

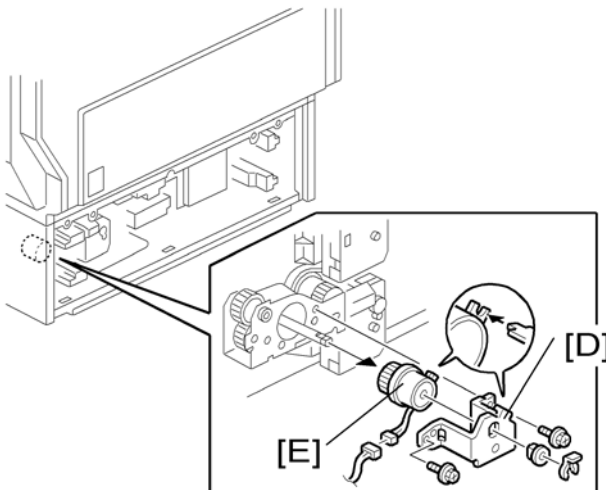

5. Lower paper feed clutch bracket [D] ( x 1, bushing x 1, x 2)
6. Lower paper feed clutch [E] ( x 1)

Paper Feed  
Unit PB3110/  
PB3130  
D537/D580



### 1.2.3 PAPER FEED MOTOR

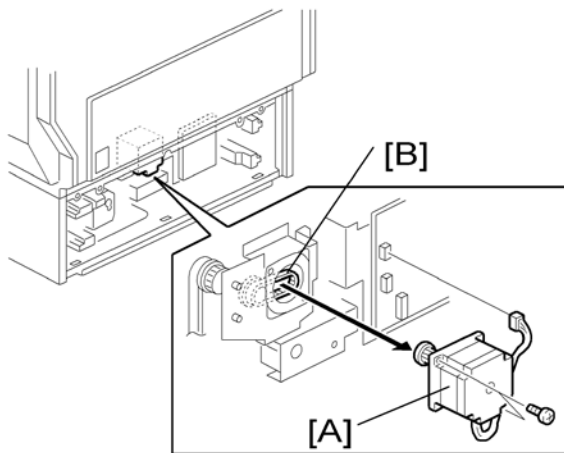

1. Rear cover (🔧 "Rear Cover")
2. Paper feed motor [A] (🔧 x 1, 🔩 x 2)

↓ Note

- When installing the paper feed motor, make sure that the gear of the paper feed motor holds the timing belt [B].

### 1.2.4 MAIN BOARD

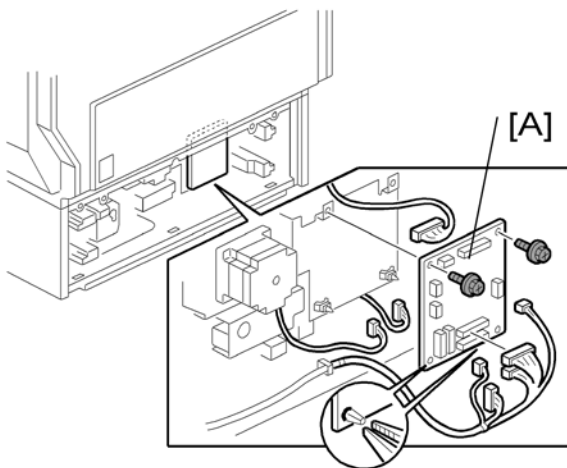

1. Rear cover (🔧 "Rear Cover")
2. Main board [A] (All 🔧s, 🔩 x 2, snap pin x 2)

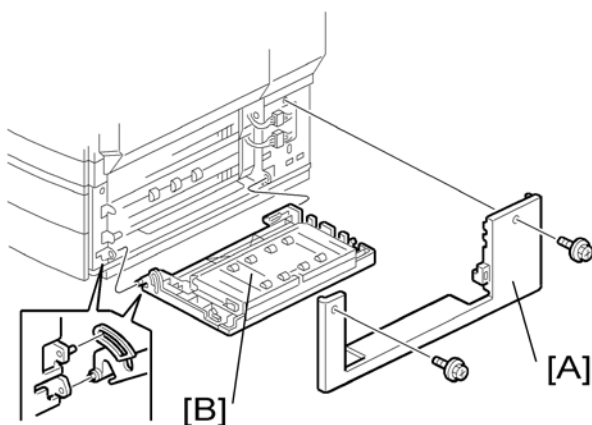

## 1.3 FEED

### 1.3.1 PAPER FEED UNIT

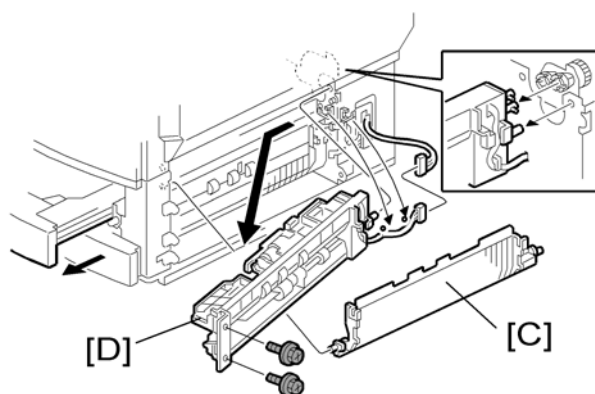

1. Right cover [A] (  x 2)
2. Vertical transport guide [B] of the paper feed unit



3. Pull the tray 3 (or 4).
4. Paper guide [C]
5. Paper feed unit [D] (  x 2,  x 1,  x 2)

When replacing the paper feed unit of tray 4, do the same.

### 1.3.2 PICK-UP, PAPER FEED AND SEPARATION ROLLERS

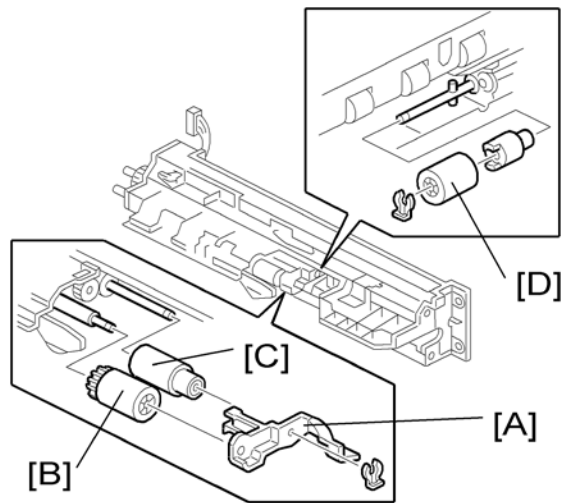

1. Paper feed unit (Paper Feed Unit)
2. Roller holder [A] (x 1)
3. Pick-up roller [B]
4. Paper feed roller [C]
5. Separation roller [D] (x 1)

### 1.3.3 LIFT, PAPER END, AND RELAY SENSORS

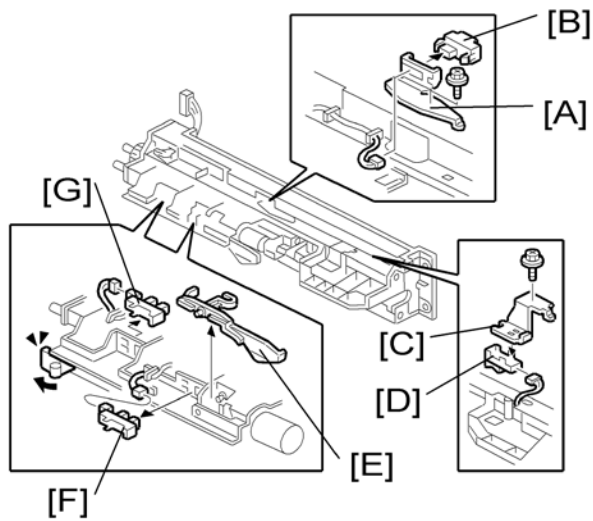

1. Paper feed unit (🔧 "Paper Feed Unit")
2. Vertical transport sensor bracket [A] (🔧 x 1)
3. Vertical transport sensor [B] (🔧 x 1)
4. Paper feed sensor bracket [C] (🔧 x 1)
5. Paper feed sensor [D] (🔧 x 1)
6. Paper end sensor filler [E]
7. Paper end sensor [F] (🔧 x 1)
8. Lift sensor [G] (🔧 x 1)

# **PB3110(D538)/PB3140(D581)**

## **LARGE CAPACITY TRAY**

<b>REVISION HISTORY</b>		
<b>Page</b>	<b>Date</b>	<b>Added/Updated/New</b>
		None



# LARGE CAPACITY TRAY (D538/D581)

## TABLE OF CONTENTS

<b>1. REPLACEMENT AND ADJUSTMENT</b> .....	<b>1</b>
1.1 EXTERIOR COVER.....	1
1.1.1 LEFT AND RIGHT TRAY.....	1
1.1.2 CHANGING THE TRAY SIZE.....	2
1.2 ELECTRICAL COMPONENTS.....	3
1.2.1 PAPER HEIGHT SENSORS ON PAPER STORAGE SIDE.....	3
1.2.2 END FENCE HP SENSOR/PAPER END SENSOR 2.....	3
1.2.3 TRAY LIFT MOTOR.....	4
1.2.4 TRAY MOTOR.....	5
1.2.5 MAIN BOARD.....	5
1.2.6 STACK TRANSPORT CLUTCH.....	6
1.3 FEED.....	7
1.3.1 PAPER FEED UNIT.....	7
1.3.2 PICK-UP, FEED AND SEPARATION ROLLERS.....	8
1.3.3 PAPER FEED, PAPER END, LIFT AND RELAY SENSORS.....	9





# 1. REPLACEMENT AND ADJUSTMENT

## 1.1 EXTERIOR COVER

### 1.1.1 LEFT AND RIGHT TRAY

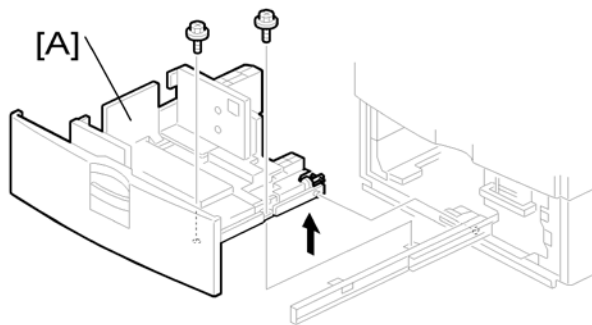

1. Pull the LCT drawer.

↓ Note

- If the right tray comes up with the left tray, push the right tray into the LCT.

2. Left tray [A] (  x 2)

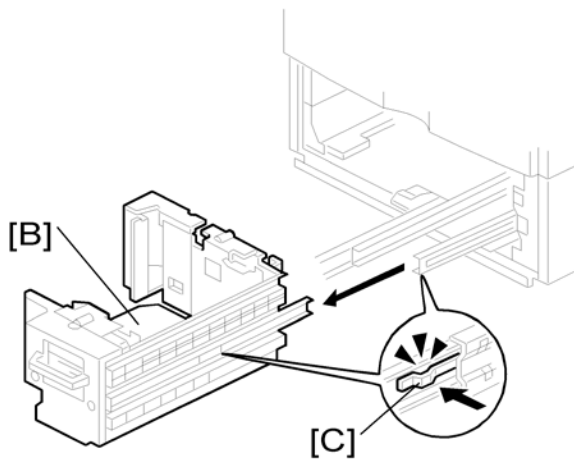

3. Remove the right tray [B] pressing down the stopper [C].

↓ Note

- When reinstalling the tray, set the tray on the guide rail and carefully push the tray in, making sure to keep the tray level.

Large  
Capacity Tray  
PB3110/  
PB3140  
D538/D581

## 1.1.2 CHANGING THE TRAY SIZE

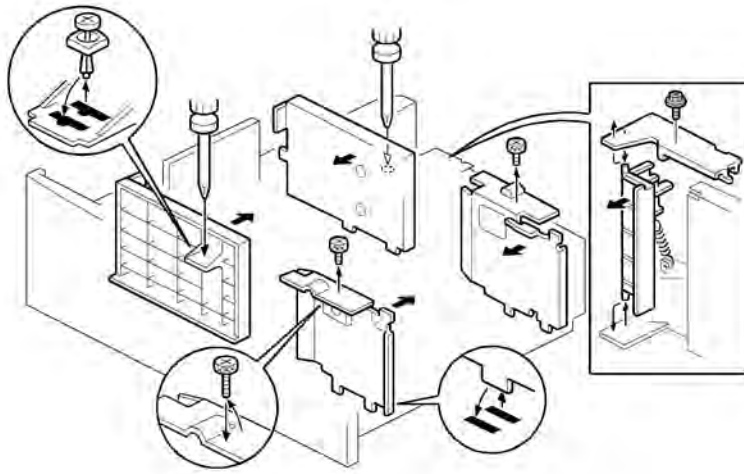

1. Remove the fence screws (  x 5).
2. Change the position of the fences.

 Note

- Before fastening the screws, set paper in the tray.

## 1.2 ELECTRICAL COMPONENTS

### 1.2.1 PAPER HEIGHT SENSORS ON PAPER STORAGE SIDE

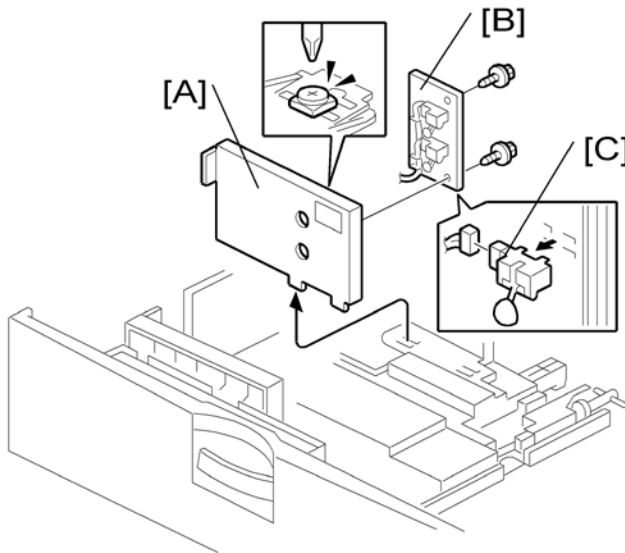

1. Tray (☞ "Left and Right Tray")
2. Rear fence [A] (🔩 x 1)
3. Rear fence bracket [B] (🔩 x 2)
4. Paper height sensors [C] (🔩 x 1 each)

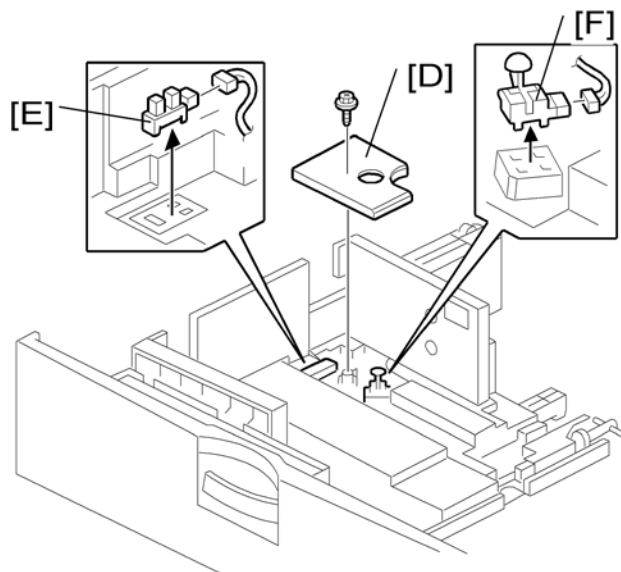

### 1.2.2 END FENCE HP SENSOR/PAPER END SENSOR 2



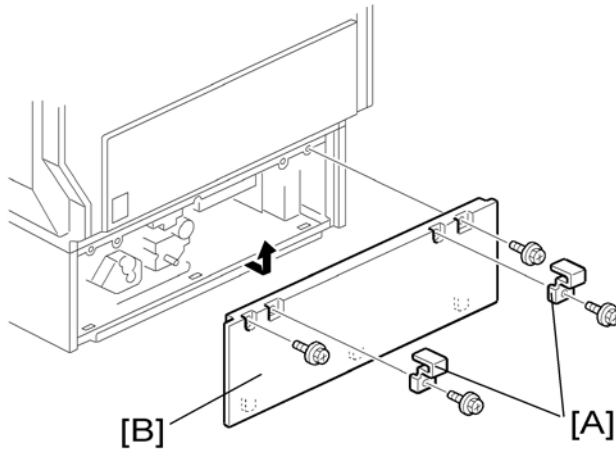

1. Bottom cover [D] (🔩 x 1)
2. End fence HP sensor [E] (🔩 x 1)
3. Paper end sensor 2 (paper storage side) [F] (🔩 x 1)

### 1.2.3 TRAY LIFT MOTOR

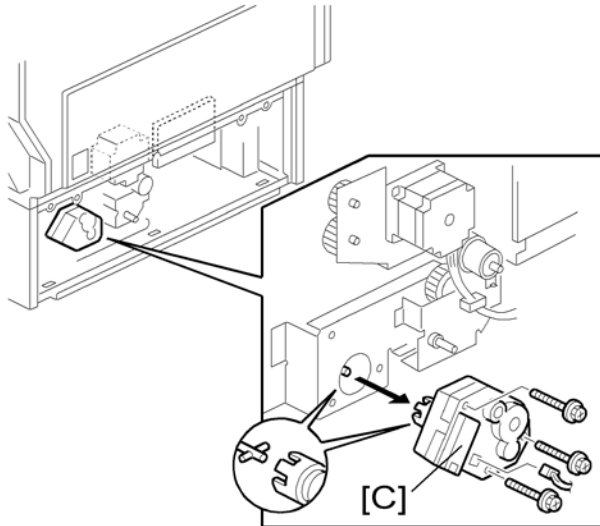

1. Securing brackets [A] (  x 1 each)
2. Rear cover [B] (  x 2)



3. Tray lift motor [C] (  x 1,  x 3)

## 1.2.4 TRAY MOTOR

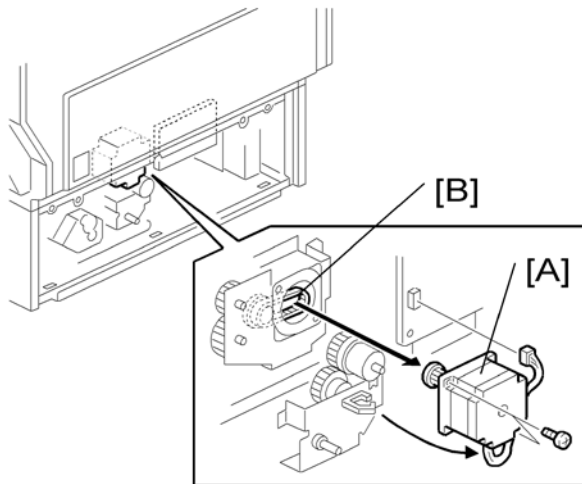

1. Rear cover (🔧 "Tray Lift Motor")
2. Tray motor [A] (🔧 x 1, 🔩 x 2)

↓ Note

- When installing the tray motor, make sure that the gear of the tray motor holds the timing belt [B].

## 1.2.5 MAIN BOARD

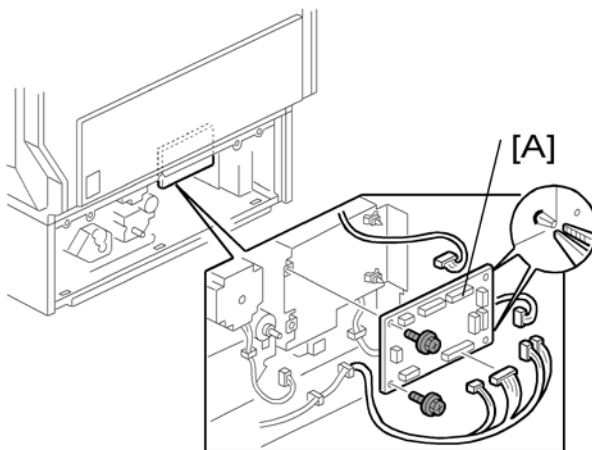

1. Rear cover (🔧 "Tray Lift Motor" )
2. Main board [A] (All 🔧s, 🔩 x 2, snap x 2)

Large Capacity Tray  
 PB3110/  
 PB3140  
 D538/D581

## 1.2.6 STACK TRANSPORT CLUTCH

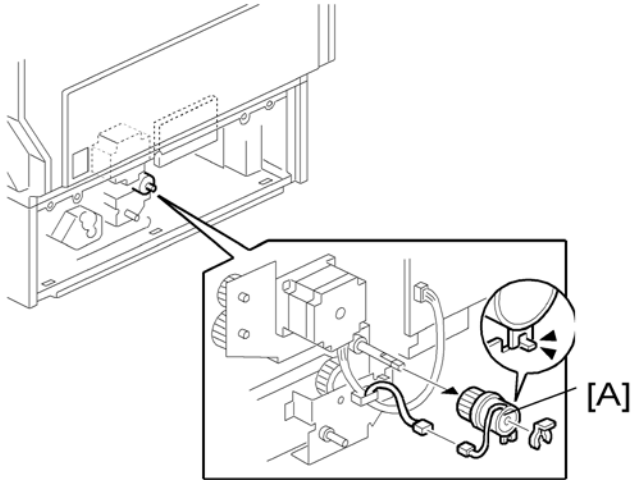

1. Rear cover (🔧 "Tray Lift Motor")
2. Stack transport clutch [A] (🔧 x 1, ⚙️ x 1)

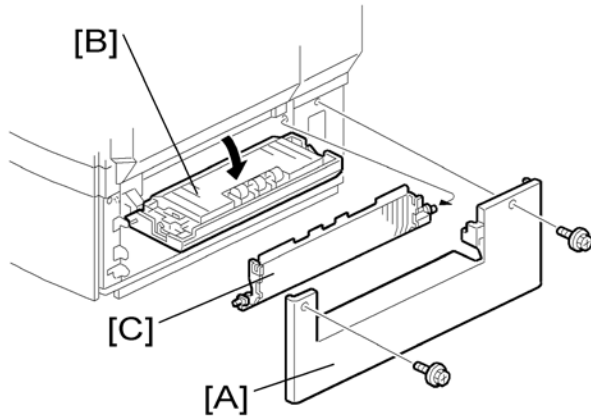

## 1.3 FEED

### 1.3.1 PAPER FEED UNIT

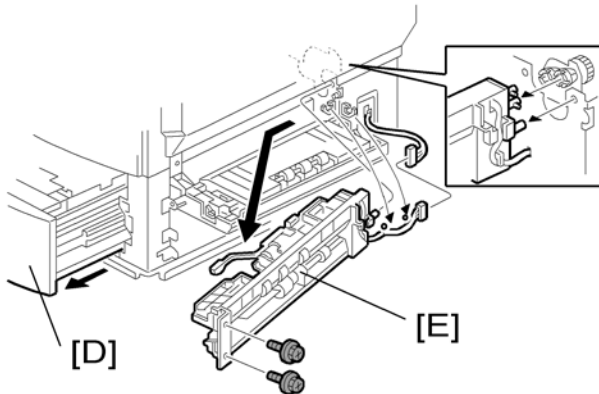

1. Right cover [A]
2. Open the vertical guide plate [B]
3. Guide plate [C]



4. Pull the LCT drawer [D].
5. Paper feed unit [E] (  x 2  x 1 )

Large Capacity Tray  
PB3110/  
PB3140  
D538/D581

### 1.3.2 PICK-UP, FEED AND SEPARATION ROLLERS

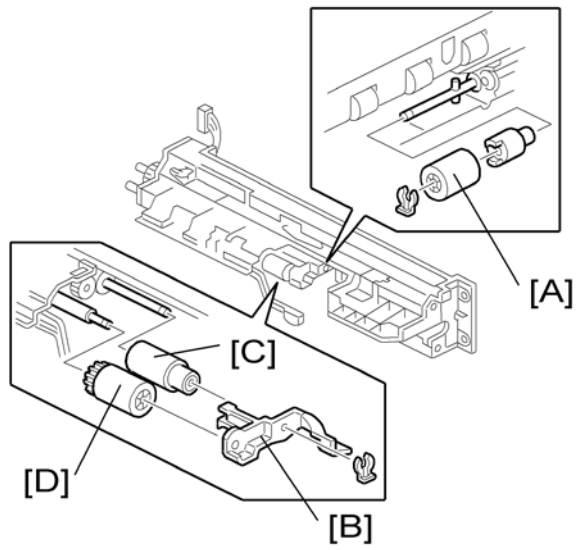

1. Paper feed unit (🔌 "Paper Feed Unit")
2. Separation roller [A] (🔧 x 1)
3. Roller holder [B] (🔧 x 1)
4. Feed roller [C] and pick-up roller [D]



### 1.3.3 PAPER FEED, PAPER END, LIFT AND RELAY SENSORS

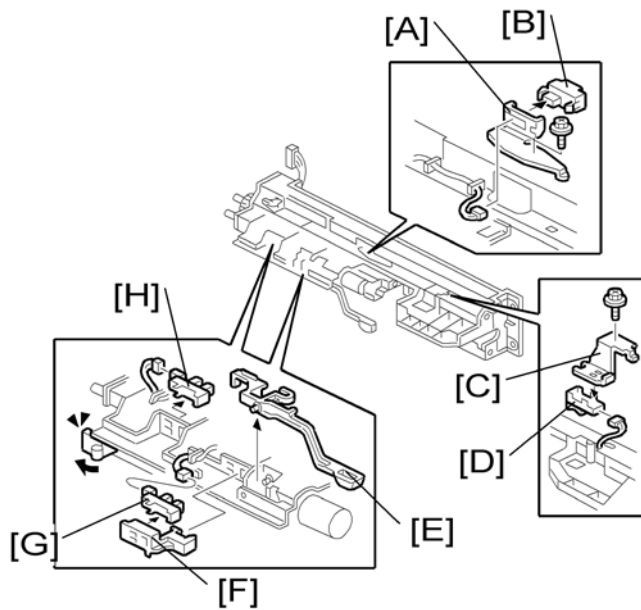

1. Paper feed unit (🔧 "Paper Feed Unit")
2. Vertical transport sensor bracket [A] (🔩 x 1, 🪝 x 1)
3. Relay sensor [B]
4. Paper feed sensor bracket [C]
5. Paper feed sensor [D]
6. Paper end feeler [E]
7. Paper end sensor holder [F] (hook x 3)
8. Paper end sensor [G] (🪝 x 1, hook x 3)
9. Lift sensor (🪝 x 1, hook x 3)

Large  
Capacity Tray  
PB3110/  
PB3140  
D538/D581

**D631**

**RT3020 - 1200-SHEET LCT**

<b>REVISION HISTORY</b>		
<b>Page</b>	<b>Date</b>	<b>Added/Updated/New</b>
		None



# RT3020 - 1200-SHEET LCT (D631)

## TABLE OF CONTENTS

<b>1. REPLACEMENT AND ADJUSTMENT.....</b>	<b>1</b>
1.1 COVERS.....	1
1.1.1 REAR COVER.....	1
1.1.2 RIGHT DOOR.....	1
1.1.3 FRONT AND TOP COVERS .....	2
1.2 PAPER FEED .....	3
1.2.1 PICK-UP, PAPER FEED AND SEPARATION ROLLERS .....	3
1.3 DRIVE.....	4
1.3.1 PAPER FEED CLUTCH.....	4
1.3.2 PAPER FEED MOTOR.....	4
1.3.3 TRAY LIFT MOTOR.....	5
1.4 ELECTRICAL COMPONENTS .....	6
1.4.1 MAIN BOARD.....	6
1.4.2 LCT SET SWITCHES .....	6
Rear .....	6
Front.....	7
1.4.3 DOWN SWITCH .....	7
1.4.4 PAPER FEED, PAPER END, TRAY LIFT AND RELAY SENSORS.....	8
1.4.5 STACK SENSOR.....	9
1.5 SIDE FENCE POSITION CHANGE .....	10
<b>2. DETAILS .....</b>	<b>11</b>
2.1 COMPONENT LAYOUT .....	11
2.1.1 COMPONENT LAYOUT .....	11
2.1.2 ELECTRICAL COMPONENT LAYOUT .....	12
2.1.3 ELECTRICAL COMPONENT DESCRIPTIONS.....	13
2.1.4 DRIVE LAYOUT .....	15
2.2 PAPER FEED .....	16
2.2.1 PAPER FEED MECHANISM .....	16
2.2.2 TRAY LIFT MECHANISM.....	17
Tray lifting conditions.....	17
Tray lowering conditions (Paper supply position) .....	17
Tray lowering conditions (Full-down position) .....	17

2.2.3 PAPER HEIGHT AND END DETECTION .....	18
Paper Height .....	18
Paper End .....	18

# Read This First

## Safety and Symbols

### Replacement Procedure Safety

#### **CAUTION**

- Turn off the main power switch and unplug the machine before beginning any of the replacement procedures in this manual.

#### Symbols Used in this Manual

This manual uses the following symbols.

: See or Refer to

: Screws

: Connector

: Clip ring

: E-ring

: Clamp



# 1. REPLACEMENT AND ADJUSTMENT

## 1.1 COVERS

### 1.1.1 REAR COVER

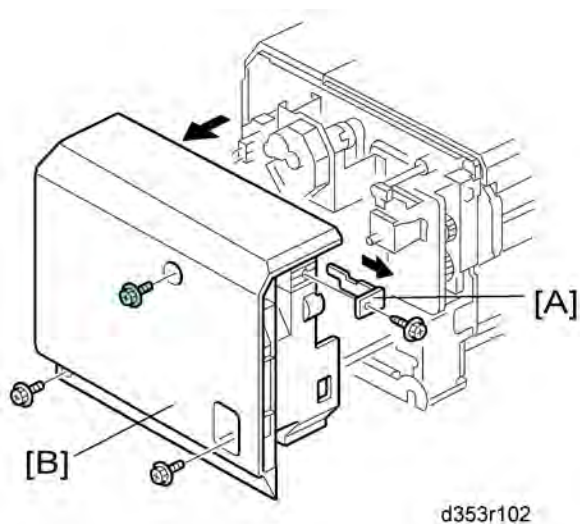

1. Cover [A] (🔩 x 1)
2. Rear cover [B] (🔩 x 3)

### 1.1.2 RIGHT DOOR

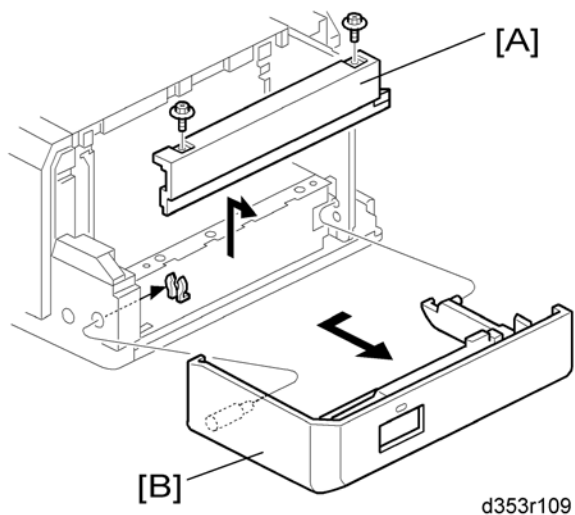

1. Right lower cover [A] (🔩 x 2)
2. Right door [B] (🔩 x 1)

RT3020 -  
1200-SHEET  
LCT  
(D631)



### 1.1.3 FRONT AND TOP COVERS

1. Right door (→ p.1 "Rear Cover")

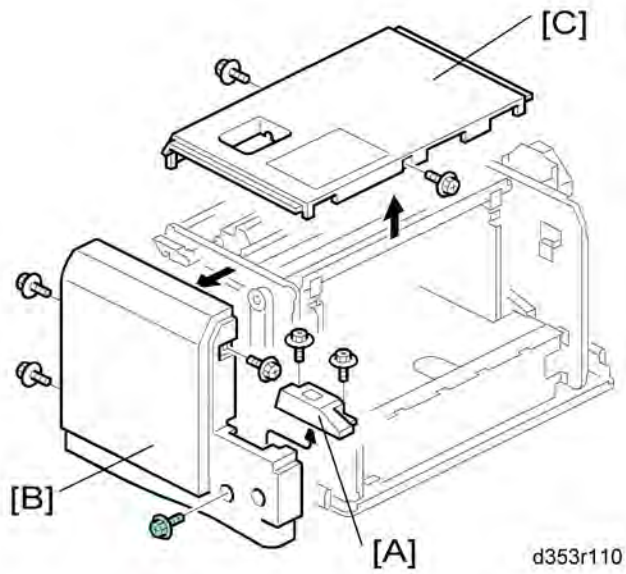

2. Switch cover [A] (🔩 x 2)
3. Front cover [B] (🔩 x 4)
4. Top cover [C] (🔩 x 2)

## 1.2 PAPER FEED

### 1.2.1 PICK-UP, PAPER FEED AND SEPARATION ROLLERS

1. Open the right door.

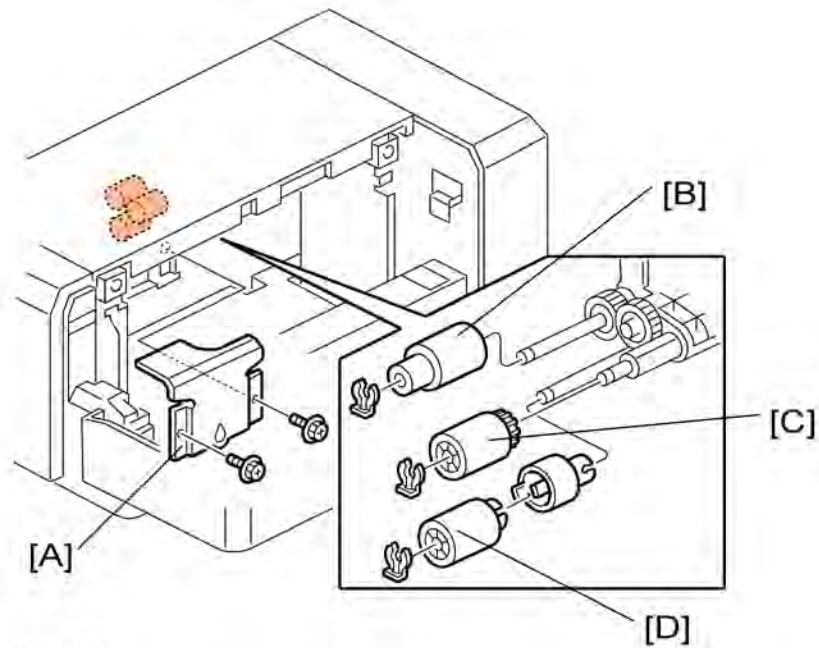

d353r101

2. Sensor bracket [A] (🔩 x 2)
3. Rollers [B], [C], [D] (🌀 x 1 each)
  - [B]: Paper feed roller
  - [C]: Pick-up roller
  - [D]: Separation roller

RT3020 -  
1200-SHEET  
LCT  
(D631)

## 1.3 DRIVE

### 1.3.1 PAPER FEED CLUTCH

1. Rear cover (➔ p.1 "Rear Cover")

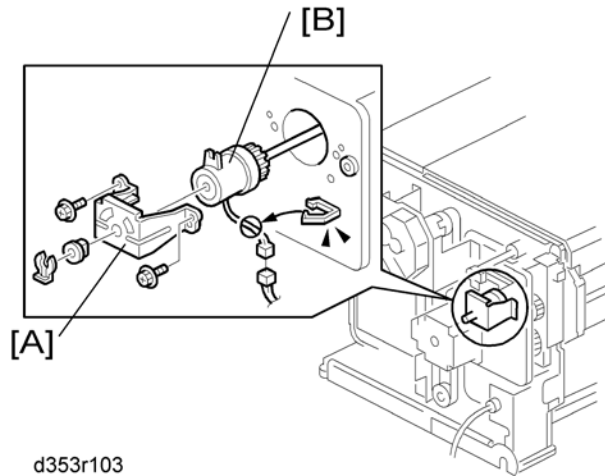

2. Bracket [A] (🔩 x 1, 🌀 x 2, bushing x 1)
3. Paper feed clutch [B] (🔩 x 1, 🌀 x 1)

### 1.3.2 PAPER FEED MOTOR

1. Rear cover (➔ p.1 "Rear Cover")

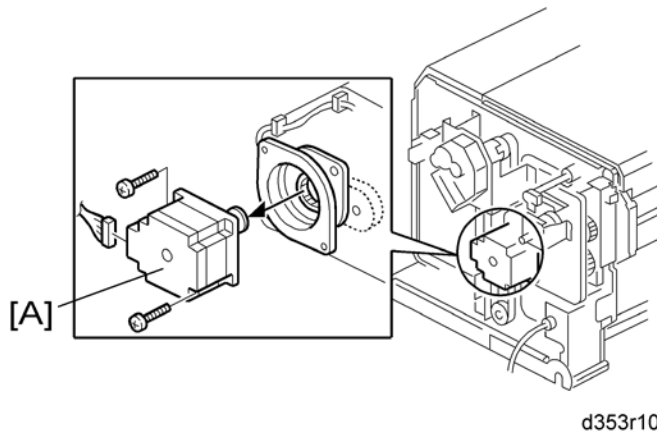

1. Paper feed motor [A] (🌀 x 2)

### 1.3.3 TRAY LIFT MOTOR

1. Rear cover (→ p.1 "Rear Cover")

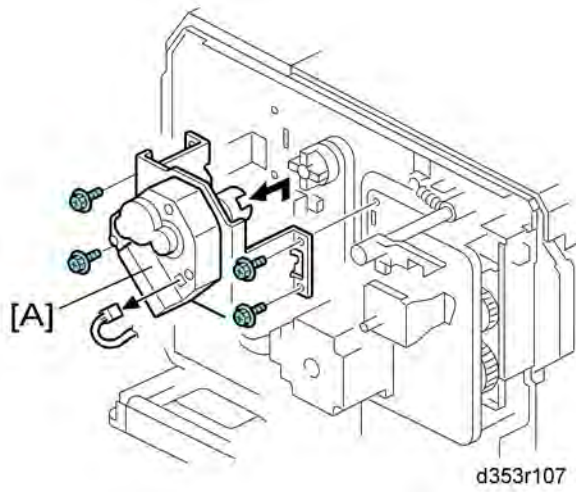

2. Tray lift motor unit [A] (⚙️ x 4, 📏 x 1)

RT3020 -  
1200-SHEET  
LCT  
(D631)

## 1.4 ELECTRICAL COMPONENTS

### 1.4.1 MAIN BOARD

1. Rear cover (➔ p.1 "Rear Cover")

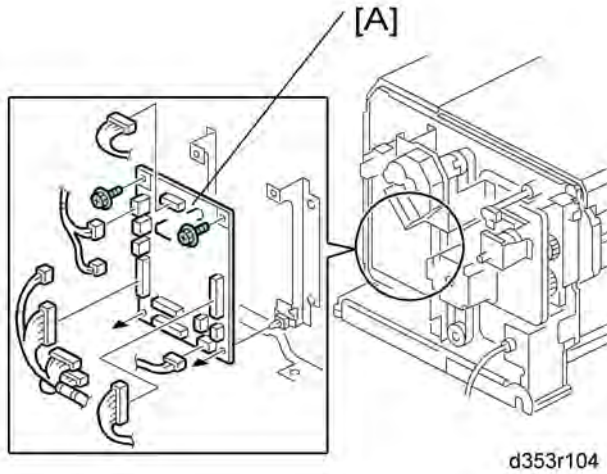

2. Main board (⚙ x 2, all ⚙'s)

### 1.4.2 LCT SET SWITCHES

#### *Rear*

1. Rear cover (➔ p.1 "Rear Cover")

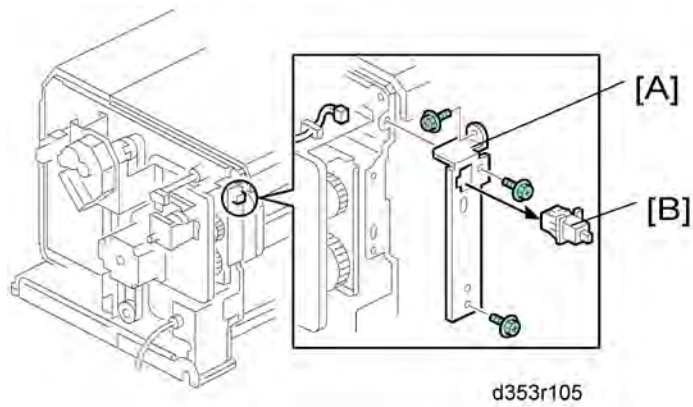

2. Switch bracket [A] (⚙ x 3)
3. Rear LCT set switch [B]

**Front**

1. Front cover (➔ p.2 "Front and Top Covers")

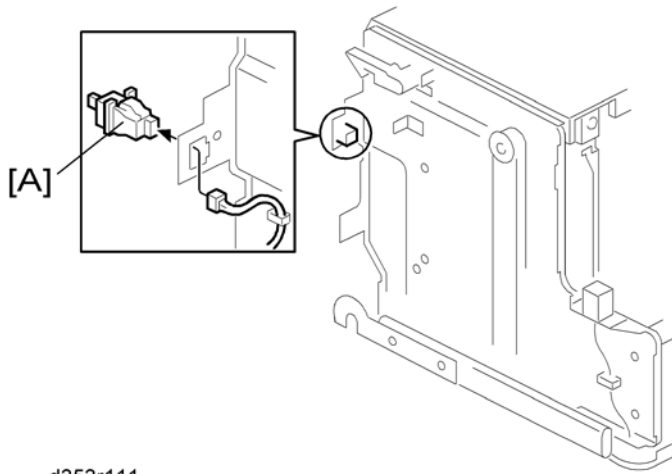

d353r111

2. Front LCT set switch [A] (🔌 x 1)

**1.4.3 DOWN SWITCH**

1. Front cover (➔ p.2 "Front and Top Covers")

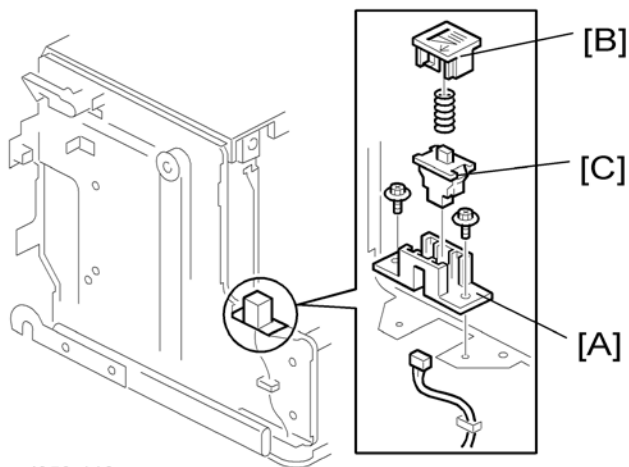

d353r112

2. Switch base [A] (🔌 x 2, 🔌 x 1)
3. Down button [B] (spring x 1)
4. Down switch [C] (hook)

RT3020 -  
1200-SHEET  
LCT  
(D631)

### 1.4.4 PAPER FEED, PAPER END, TRAY LIFT AND RELAY SENSORS

1. Front cover (↪ p.2 "Front and Top Covers")
2. Top Cover (↪ Front and Top Covers)

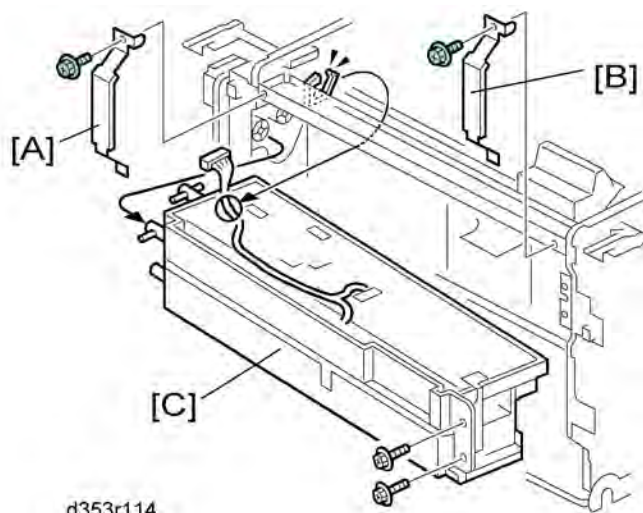

3. Rear ground plate [A] (⌘ x 1)
4. Front ground plate [B] (⌘ x 1)
5. Paper feed unit [C] (⌘ x 2, ⌘ x 1, ⌘ x 1)

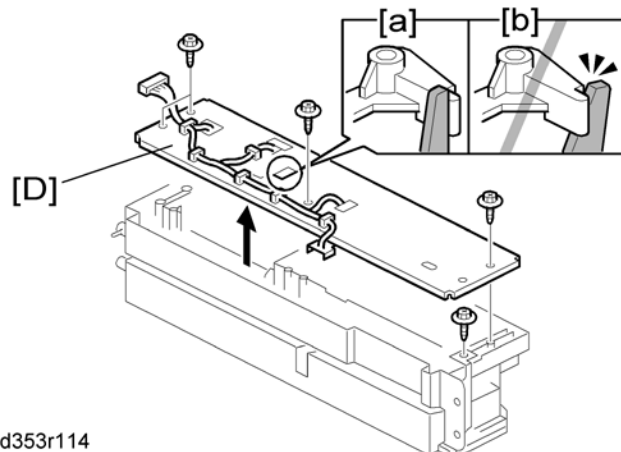

6. Paper feed unit cover [D] (⌘ x 5, ⌘ x 1)

**Note**

- Before you re-install the paper feed unit cover, make sure that the pick-up solenoid holds the pick-up roller lever ([a]: correct, [b]: incorrect) and the pick-up roller works properly.

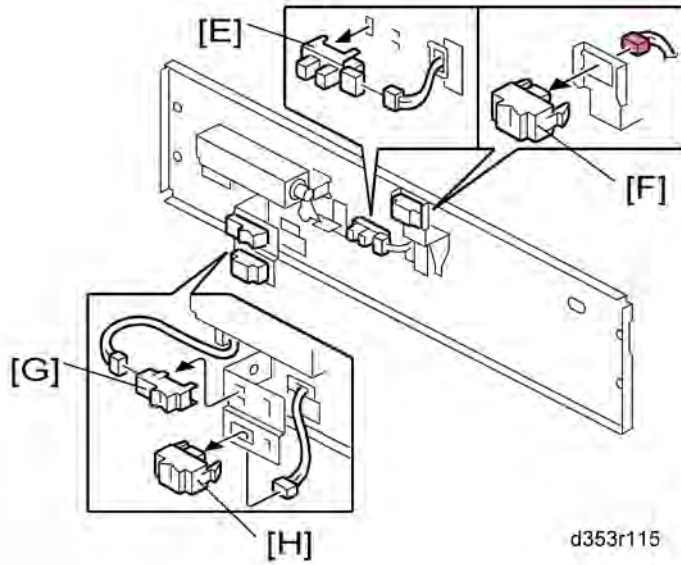

7. Sensors [E], [F], [G], [H] (☞ x 1, hooks each)
  - [E]: Tray lift sensor
  - [F]: Relay sensor
  - [G]: Paper feed sensor
  - [H]: Paper end sensor

### 1.4.5 STACK SENSOR

1. Open the right door
2. Paper feed unit (☞ p.8 "Paper Feed, Paper End, Tray Lift and Relay Sensors")

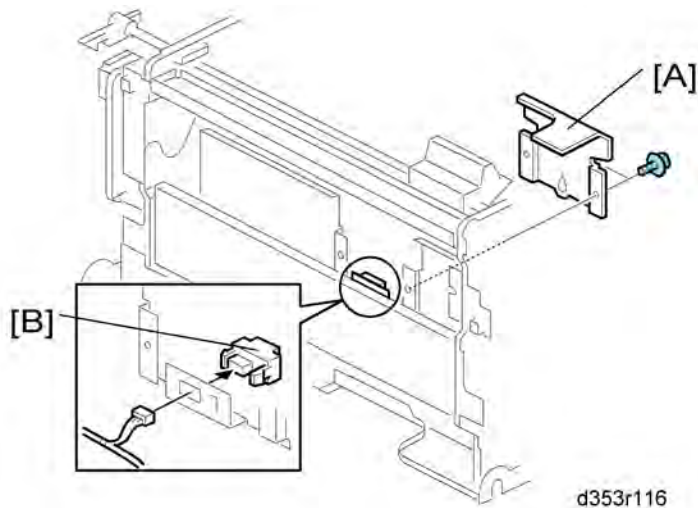

3. Sensor bracket [A] (☞ x 2)
4. Stack sensor [B] (☞ x 1)



## 1.5 SIDE FENCE POSITION CHANGE

1. Open the right door of the LCT.
2. Push the down switch to lower the tray bottom plate until it reaches its lowest position.

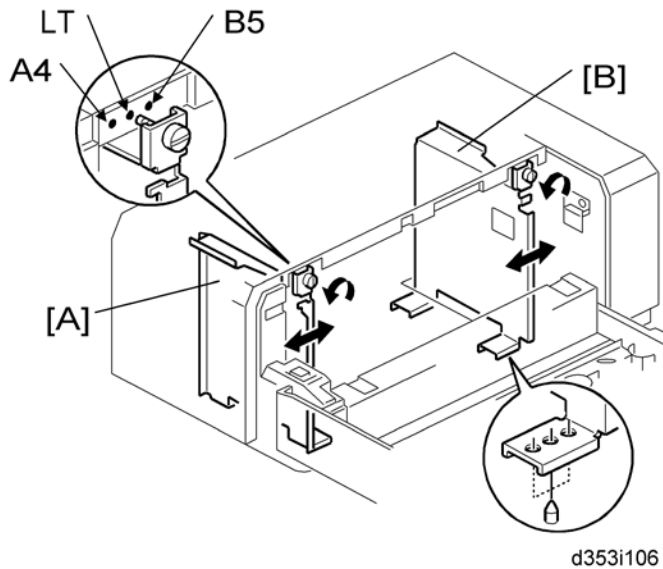

3. Remove the front and rear side fences [A, B] (⌘ x 1 each).
4. Install the side fences in the correct position (A4 LEF/ LT LEF/ B5 LEF).

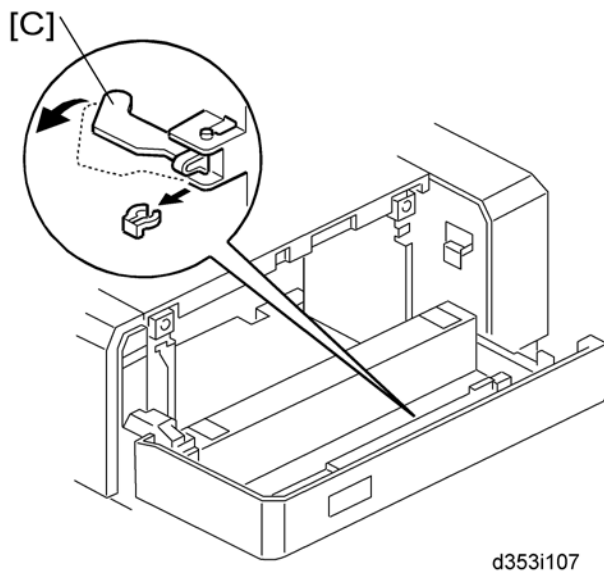

5. Pull the end fence [C] for B5 size paper as shown (⌘ x 1) if the the side fences are adjusted for B5 size paper.
6. Close the right door.
7. Turn on the main power switch, and then go into the SP mode.
8. Input the correct paper size for the1200-sheet LCT with SP5181-017.

## 2. DETAILS

### 2.1 COMPONENT LAYOUT

#### 2.1.1 COMPONENT LAYOUT

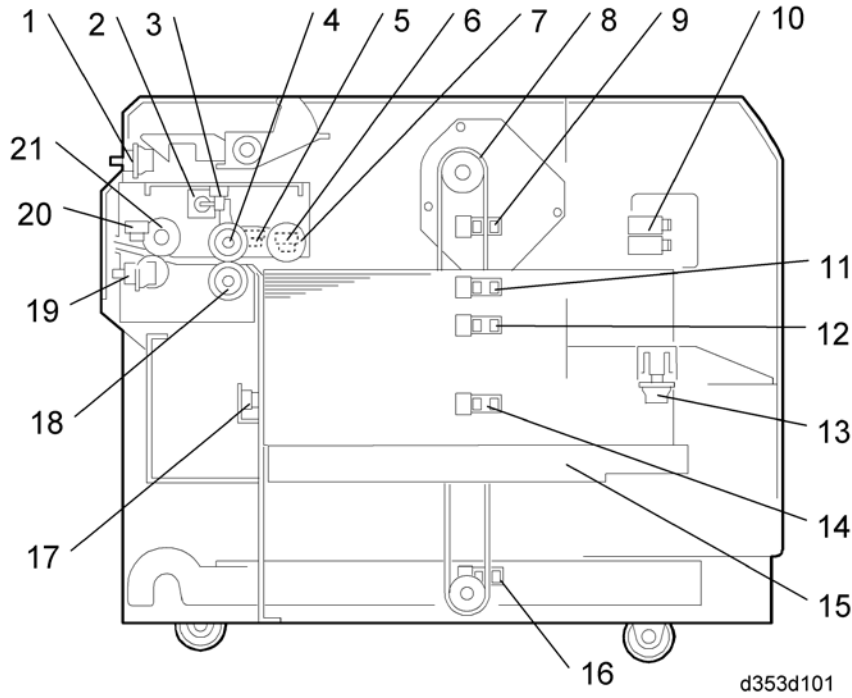

RT3020 -  
1200-SHEET  
LCT  
(D631)

- 1. Rear LCT Set Switch
- 2. Pick-up Roller Solenoid
- 3. Tray Lift Sensor
- 4. Paper Feed Roller
- 5. Paper Feed Sensor
- 6. Paper End Sensor
- 7. Pick-up Roller
- 8. Tray Lift Motor
- 9. Paper Height Sensor 1
- 10. Interlock Switches
- 11. Paper Height Sensor 2

- 12. Sub Paper Height Sensor
- 13. Tray Down Switch
- 14. Paper Height Sensor 3
- 15. Paper Tray
- 16. Lower Limit Sensor
- 17. Stack Sensor
- 18. Separation Roller
- 19. Front LCT Set Switch
- 20. Relay Sensor 5
- 21. Relay Roller

## 2.1.2 ELECTRICAL COMPONENT LAYOUT

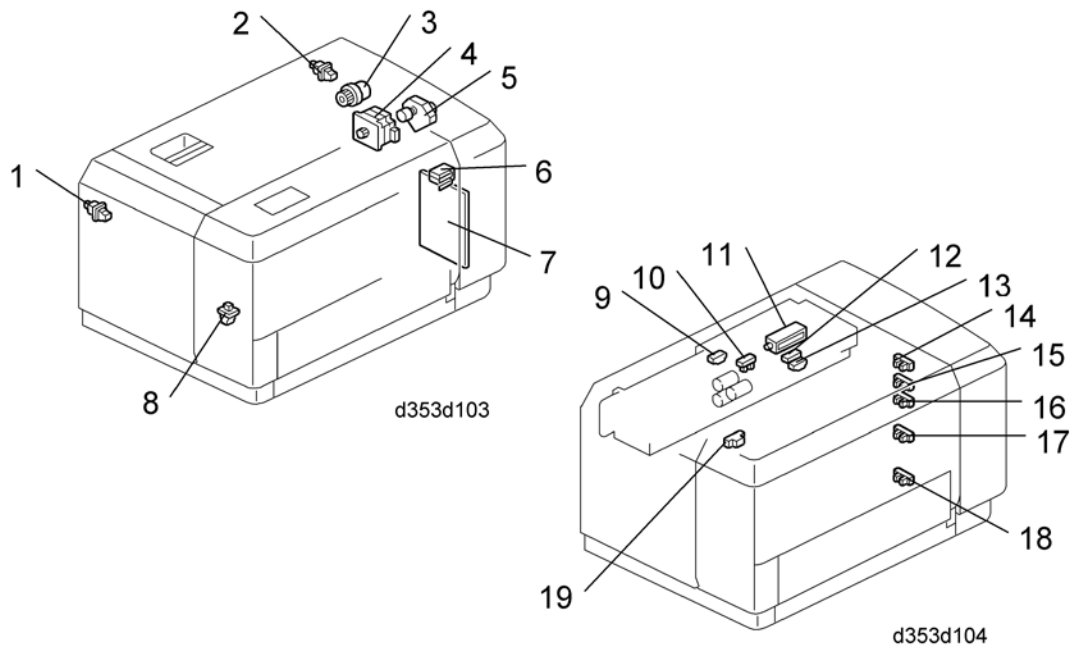

1. Front LCT Set Switch
2. Rear LCT Set Switch
3. Paper Feed Clutch
4. Paper Feed Motor
5. Tray Lift Motor
6. Interlock Switches
7. Main Board
8. Tray Down Switch
9. Relay Sensor
10. Tray Lift Sensor

11. Pick-up Roller Solenoid
12. Paper Feed Sensor
13. Paper End Sensor
14. Paper Height Sensor 1
15. Paper Height Sensor 2
16. Sub Paper Height Sensor
17. Paper Height Sensor 3
18. Lower Limit Sensor
19. Stack Sensor

### 2.1.3 ELECTRICAL COMPONENT DESCRIPTIONS

Symbol	Name	Function	Index No.
<b>Motors</b>			
M1	Paper Feed	Drives all rollers.	4
M2	Tray Lift	Drives the paper tray up or down.	5
<b>Sensors</b>			
S1	Paper Feed	Detects whether the paper is jammed at the LCT.	12
S2	Relay	Detects the copy paper coming to the relay roller and checks for misfeeds.	9
S3	Paper End	Informs the mainframe when the paper in the tray has been used up and indicates paper end.	13
S4	Tray Lift	Detects when the paper is at the correct paper feed height.	10
S5	Paper Height 1	Detects the amount of paper remaining in the tray.	14
S6	Paper Height 2		15
S7	Sub Paper Height		16
S8	Paper Height 3		17
S9	Lower Limit		Detects when the tray is completely lowered, to stop the tray lift motor.

RT3020 -  
1200-SHEET  
LCT  
(D631)

Component Layout

Symbol	Name	Function	Index No.
S10	Stack	Detects a) when the tray has moved down to the paper supply position after paper end, to stop the tray lift motor or b) when the top of the paper stack has moved down to the paper supply position, to stop the tray lift motor after the down switch has been pressed.	19
<b>Switches</b>			
SW1	Right Door	Detects whether the right door is open and starts to drive the tray lift motor.	6
SW2	Front LCT Set	Detects whether the LCT is correctly set.	1
SW3	Rear LCT Set	Detects whether the LCT is correctly set.	2
SW4	Down	Lowers the tray to the paper supply position if pressed.	8
<b>Magnetic Clutches</b>			
MC1	Paper Feed	Drives the paper feed unit.	3
<b>Solenoids</b>			
SOL1	Pick-up	Pushes the pick-up roller up or down.	11
<b>PCBs</b>			
PCB1	Main	Controls the LCT and communicates with the copier/printer.	7

### 2.1.4 DRIVE LAYOUT

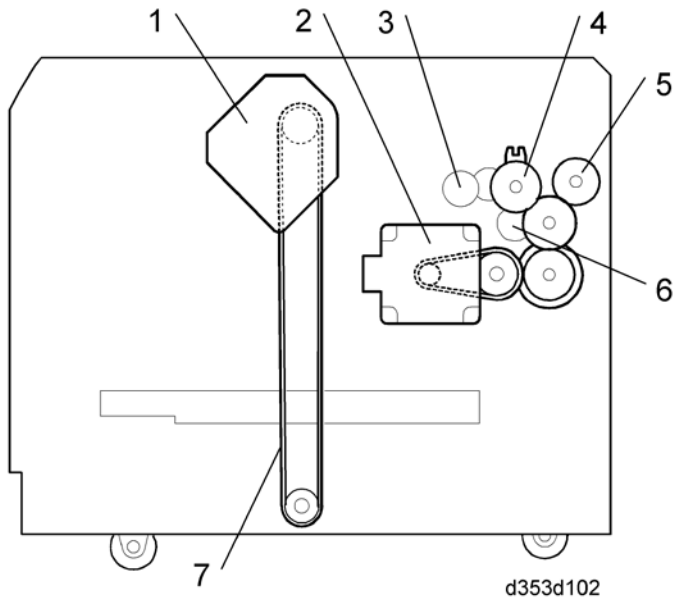

- |   |   |
|---|---|
| <ul style="list-style-type: none"><li>1. Tray Lift Motor</li><li>2. Paper Feed Motor</li><li>3. Pick-up Roller</li><li>4. Paper Feed Clutch</li></ul> | <ul style="list-style-type: none"><li>5. Relay Roller</li><li>6. Separation Roller</li><li>7. Tray Drive Belt</li></ul> |
|---|---|



RT3020 -  
1200-SHEET  
LCT  
(D631)

## 2.2 PAPER FEED

### 2.2.1 PAPER FEED MECHANISM

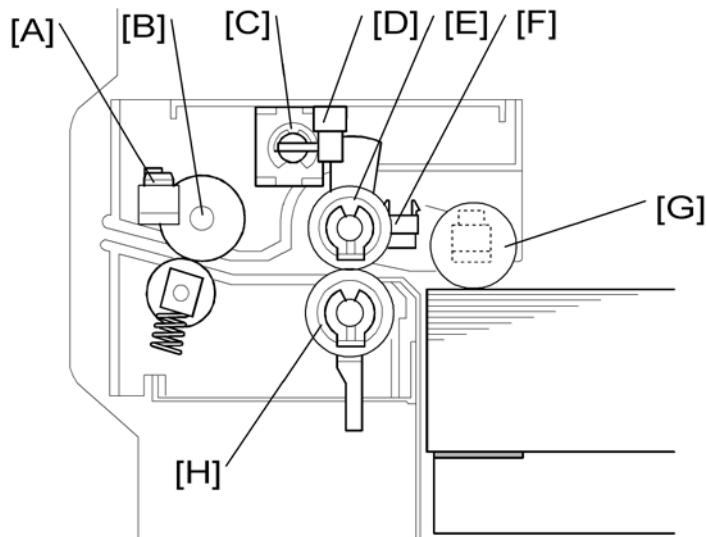

d353d105

This machine uses the FRR paper feed system (paper feed roller [E], separation roller [H], pick-up roller [G]).

When the right door is closed, the tray lift motor raises the tray to the position where the top of the paper stack in the tray interrupts the tray lift sensor [D]. The paper feed motor switches on, then the pick-up solenoid [C] switches off and the pick-up roller drops onto the top of the stack of paper. The paper feed clutch transfers drive to the paper feed roller [E], pick-up roller [G] and separation roller [H].

The rotating pick-up roller lowers and feeds the first sheet when it contacts the top of the stack.

The separation roller [H], in contact with the feed roller, only allows one sheet out of the tray.

As soon as the paper feed sensor [F] detects the leading edge of the paper, it switches off the pick-up solenoid which raises the pick-up roller. The feed roller feeds the sheet to the registration roller in the main machine through the relay roller [B].

This process is repeated for each sheet.

The paper feed sensor [F] detects "JAM7" and the relay sensor [A] detects "JAM58".

## 2.2.2 TRAY LIFT MECHANISM

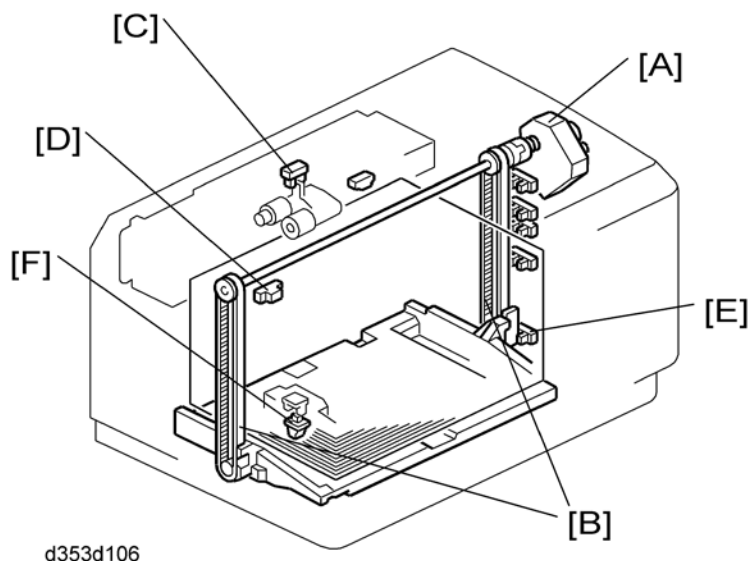

The lift motor [A] controls the vertical position of the tray through the timing belts [B].

### ***Tray lifting conditions***

When the tray lift sensor [C] turns off in the following conditions, the tray lift motor raises the tray bottom plate until the tray lift sensor [C] turns on again.

- Just after the main switch is turned on
- During copying
- Just after the tray cover is closed
- Just after leaving the energy saving mode

### ***Tray lowering conditions (Paper supply position)***

In the following conditions, the tray lift motor lowers the tray until the stack sensor [D] turns on (this is the correct tray position for supplying paper).

- Just after the paper end sensor turns on
- Just after the down switch is pressed by the user

### ***Tray lowering conditions (Full-down position)***

In the following condition, the tray lift motor lowers the tray until the lower limit sensor [E] turns on (this is the correct tray position for adding 500 sheets of paper after installing the first stack of paper in the LCT tray).

- Just after the down switch [F] is pressed for 3 seconds or more when the tray is at the paper supply position.

RT3020 -  
1200-SHEET  
LCT  
(D631)



## 2.2.3 PAPER HEIGHT AND END DETECTION

### *Paper Height*

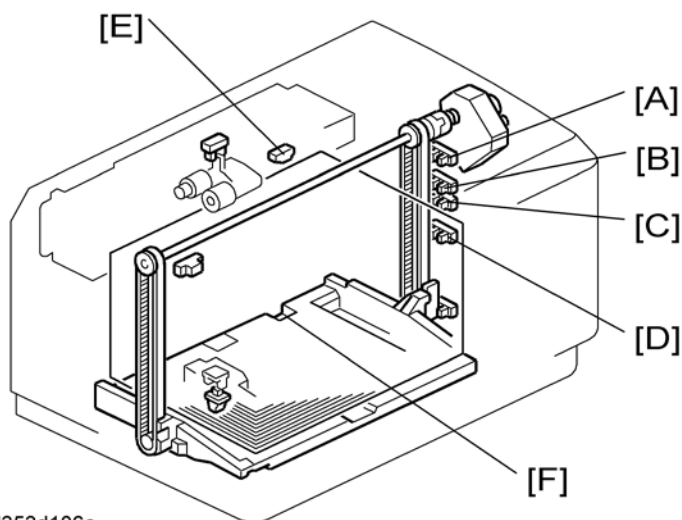

d353d106a

The amount of the paper in the tray is detected by combination of high (1)/low (0) outputs from three sensors (paper height sensor 1 [A], 2 [B], 3 [D] and sub paper height sensor [C]).

Amount of paper	PH S-1	PH S-2	PH S-3	Sub PH S	Indicator on the operation panel
100%	0	0	0	0	Four lines
70%	0	0	1	-	Three lines
	0	0	0	1	
30%	0	1	-	-	Two lines
10%	1	-	-	-	One line
End	-	-	-	-	No line

0: No interruption (low), 1: Interruption (high), -: No checking

PH S: Paper Height Sensor

### *Paper End*

The paper end sensor [E] monitors the light reflected by each sheet on top of the stack.

When the last sheet feeds, the cutout [F] is exposed, and the paper end sensor receives no reflected light from below because there is no paper. As a result, this signals paper end.

RT3020 -  
1200-SHEET  
LCT  
(D631)

**BOOKLET FINISHER SR3020 (B803)/  
SR3110 (D637)/SR4020 (D373)  
FINISHER SR3030 (B805)/  
SR3120 (D636)/SR4010 (D374)**

<b>REVISION HISTORY</b>		
<b>Page</b>	<b>Date</b>	<b>Added/Updated/New</b>
		None



# **BOOKLET FINISHER SR3020 (B803)/ SR3110 (D637)/SR4020 (D373) FINISHER SR3030 (B805)/ SR3120 (D636)/SR4010 (D374)**

## **TABLE OF CONTENTS**

<b>1. REPLACEMENT AND ADJUSTMENT.....</b>	<b>1</b>
1.1 COVERS.....	1
1.1.1 EXTERIOR COVERS .....	1
1.1.2 UPPER TRAY, END FENCE .....	2
1.2 MAIN UNIT.....	3
1.2.1 UPPER TRAY LIMIT SENSOR, LIMIT SWITCH .....	3
1.2.2 POSITIONING ROLLER.....	4
1.2.3 PROOF TRAY EXIT SENSOR .....	5
1.2.4 UPPER TRAY HEIGHT SENSORS 1, 2.....	5
1.2.5 EXIT GUIDE PLATE, UPPER TRAY EXIT SENSOR .....	6
1.2.6 PROOF TRAY FULL SENSOR.....	7
1.2.7 FINISHER ENTRANCE SENSOR .....	7
1.2.8 PRE-STACK TRAY EXIT SENSOR.....	8
1.3 STAPLER UNIT .....	9
1.3.1 CORNER STAPLER.....	9
1.3.2 POSITIONING ROLLER.....	10
1.4 FOLD UNIT.....	11
1.4.1 FOLD UNIT.....	11
1.4.2 FOLD UNIT ENTRANCE SENSOR .....	13
1.4.3 FOLD UNIT EXIT SENSOR.....	14
1.4.4 STACK PRESENT SENSOR.....	15
1.4.5 FOLDING HORIZONTAL SKEW ADJUSTMENT (FOR B804 ONLY) .....	16
1.4.6 FOLD VERTICAL SKEW ADJUSTMENT (FOR B804 ONLY) .....	19
1.5 BOOKLET STAPLER UNIT .....	21
1.5.1 BOOKLET STAPLER.....	21
1.5.2 BOOKLET STAPLER MOTOR .....	22
To Reattach the Booklet Stapler Motor .....	23

<b>2. DETAILED SECTION DESCRIPTIONS .....</b>	<b>24</b>
2.1 COMPONENT LAYOUT .....	24
2.1.1 GENERAL LAYOUT .....	24
Paper direction .....	24
Proof tray.....	25
Upper tray .....	25
Pre-stack tray .....	25
Lower tray .....	25
2.1.2 ELECTRICAL COMPONENTS .....	26
Upper Area B804/B805 .....	26
Lower Area B804/B805 .....	27
Punch Unit B702 .....	28
Stacker/Stapler - B804/B805.....	29
B804 Fold unit.....	30
2.1.3 SUMMARY OF ELECTRICAL COMPONENTS.....	31
2.1.4 DRIVE LAYOUT .....	41
2.2 JUNCTION GATES.....	42
2.2.1 PROOF MODE .....	42
2.2.2 SHIFT MODE.....	42
2.2.3 STAPLE MODE .....	43
2.3 PRE-STACKING .....	44
2.4 TRAY MOVEMENT MECHANISM.....	46
2.4.1 UPPER TRAY.....	46
2.4.2 LOWER TRAY (B804 ONLY).....	48
2.5 CORNER STAPLING.....	51
2.5.1 STACKING AND JOGGING .....	51
2.5.2 STAPLER MOVEMENT.....	52
2.5.3 CORNER STAPLING.....	53
2.6 BOOKLET STAPLING (B804 ONLY).....	54
2.6.1 BOOKLET PRESSURE MECHANISM .....	54
2.6.2 BOOKLET STAPLING AND FOLDING.....	55
Overview .....	55
2.6.3 BOOKLET STAPLING AND FOLDING MECHANISMS.....	61
2.7 UPPER TRAY OUTPUT .....	64
2.7.1 FEED OUT.....	64
2.7.2 FEED OUT STACKING .....	65
2.8 PUNCH UNIT B702 (FOR B804/B805).....	66
2.8.1 OVERVIEW OF OPERATION .....	66

Skew Correction before Punching.....	66
Punch Unit Position Correction .....	67
2.8.2 PUNCH MECHANISMS.....	69
Paper Position Detection.....	69
Punch Unit Movement.....	70
Punch Selection and Firing .....	71
2.8.3 PUNCH HOPPER MECHANISM .....	72
2.9 FINISHER JAM DETECTION .....	73





# Read This First

## Safety and Symbols

### Replacement Procedure Safety

#### **CAUTION**

- Turn off the main power switch and unplug the machine before beginning any of the replacement procedures in this manual.

### Symbols Used in this Manual

This manual uses the following symbols.

: See or Refer to

: Screws

: Connector

: Clip ring

: E-ring



# 1. REPLACEMENT AND ADJUSTMENT

## 1.1 COVERS

### 1.1.1 EXTERIOR COVERS

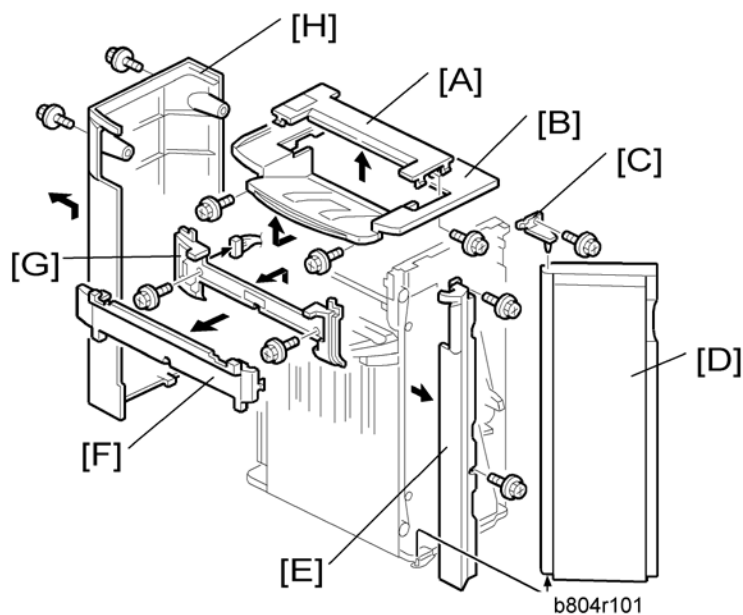

1. Open the front door [D].
2. Small upper cover [A] (🔩 x1)
3. Upper cover [B] (🔩 x2)
4. Front door bracket [C] (🔩 x1)
5. Front door [D]
6. Front left side cover [E] (🔩 x2)
7. Cover [F]
8. Paper exit cover [G] (🔩 x2)
9. Rear cover [H] (🔩 x2)

Booklet Finisher  
& Finishers  
(B803/B805/  
D373/D374/  
D636/D637)

### 1.1.2 UPPER TRAY, END FENCE

1. Remove the rear cover. (➔ "Exterior Covers")

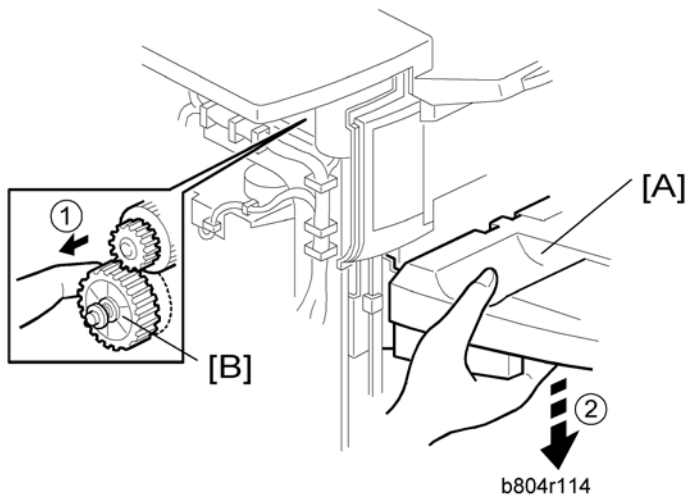

1. Support the tray [A] with your right hand.
2. Pull gear [B] toward you ① to release.
3. Slowly lower the tray ② until it stops.

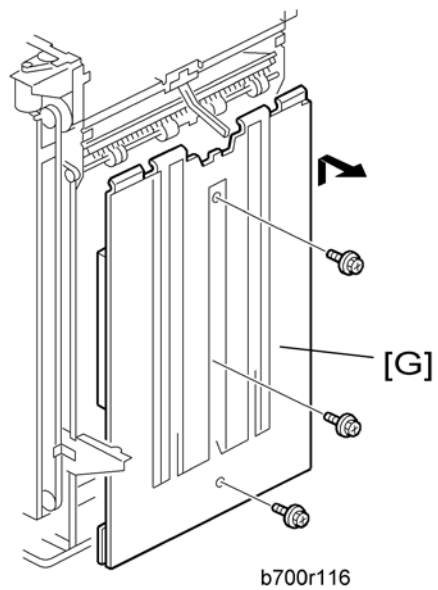
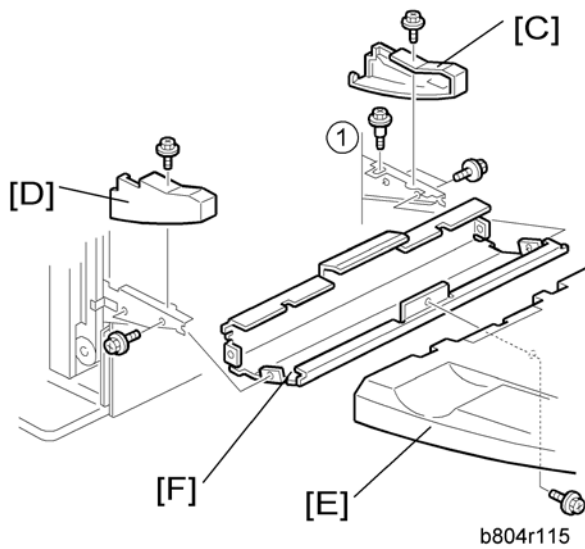

4. Front side cover [C] (⌘ x1)
5. Rear side cover [D] (⌘ x1)
6. Upper tray [E] (⌘ x1)
7. Tray bracket [F] (⌘ x4, ⌘ x1 shoulder screw ①)
8. End Fence [G](⌘ x3)

## 1.2 MAIN UNIT

### 1.2.1 UPPER TRAY LIMIT SENSOR, LIMIT SWITCH

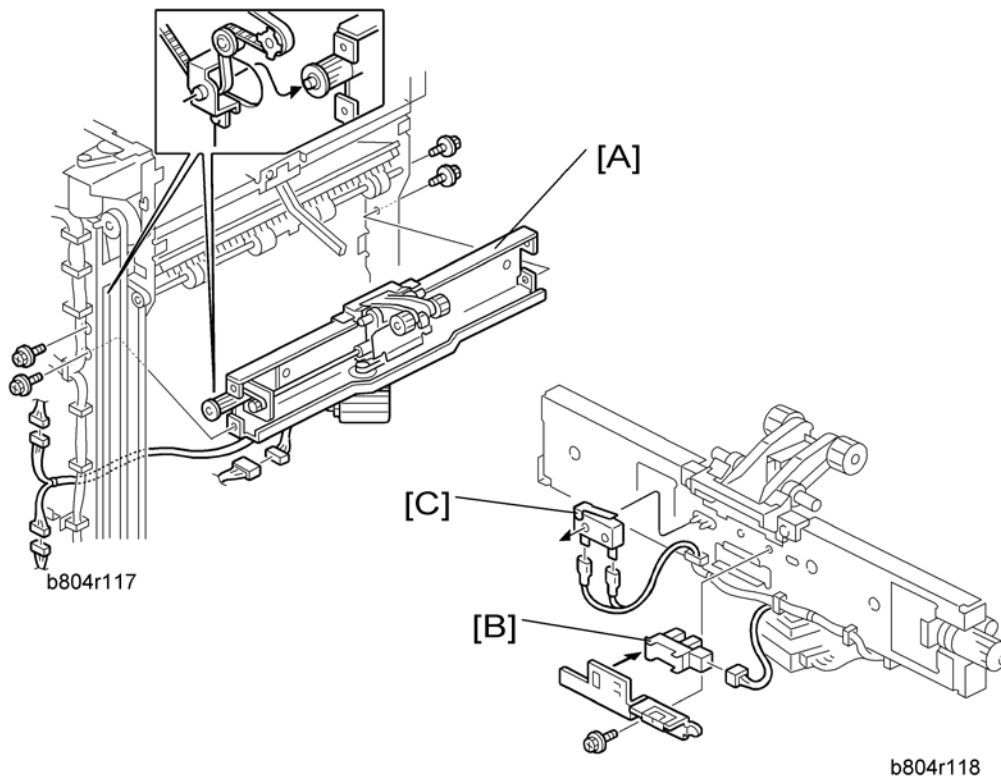

1. Front door, front left side cover, rear cover, upper cover (↔ "Exterior Cover")
2. End fence (↔ "Upper Tray, End Fence")
3. Upper tray exit mechanism [A] (⚙️ x4, 🛠️ x3)
4. Upper tray limit sensor [B] (🔌 x1, 🛠️ x1)
5. Upper tray limit switch [C] (🛠️ x2)

Booklet Finisher  
& Finishers  
(B803/B805/  
D373/D374/  
D636/D637)

## 1.2.2 POSITIONING ROLLER

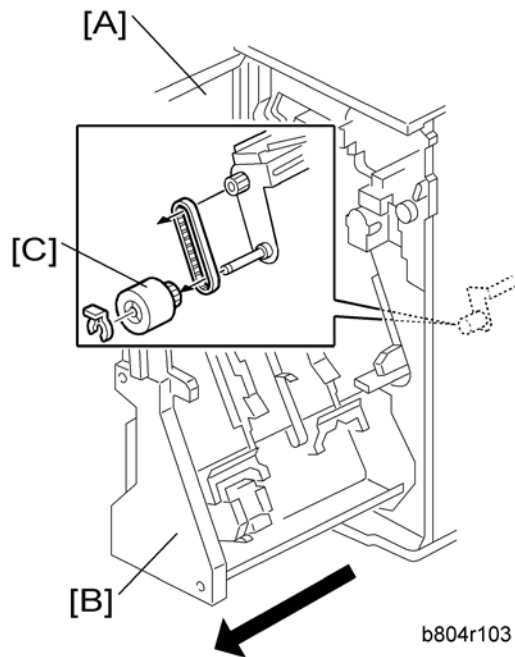

1. Open the front door [A].
2. Pull out the stapling unit [B].
3. Positioning roller [C] (⊗ x1, timing belt x1)

### 1.2.3 PROOF TRAY EXIT SENSOR

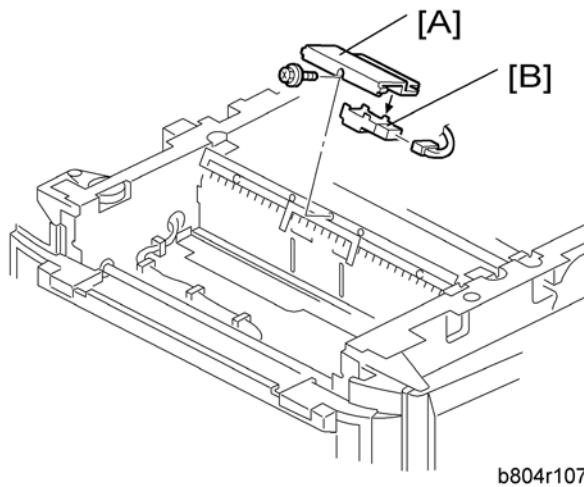

1. Small upper cover (☛ "Exterior Cover")
2. Proof tray exit sensor bracket [A] (🔩 x1)
3. Proof tray exit sensor [B] (🔌 x1)

### 1.2.4 UPPER TRAY HEIGHT SENSORS 1, 2

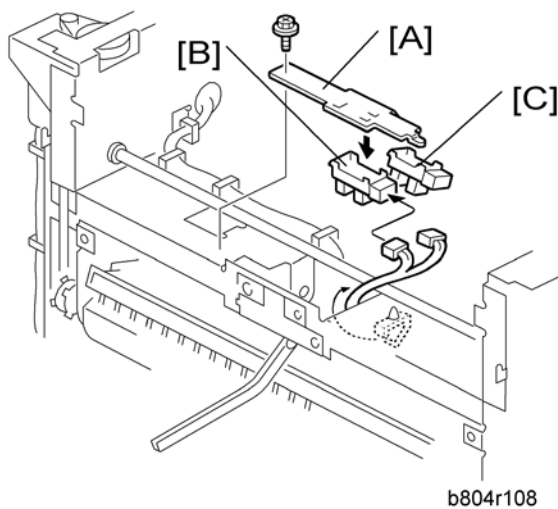

1. Small upper cover, upper cover (☛ "Exterior Cover")
2. Upper tray paper height sensor bracket [A] (🔩 x1)
3. Upper tray paper height sensor [B] – staple mode (S08) (🔌 x1)
4. Upper tray paper height sensor [C] – non-staple mode (S09) (🔌 x1)

## 1.2.5 EXIT GUIDE PLATE, UPPER TRAY EXIT SENSOR

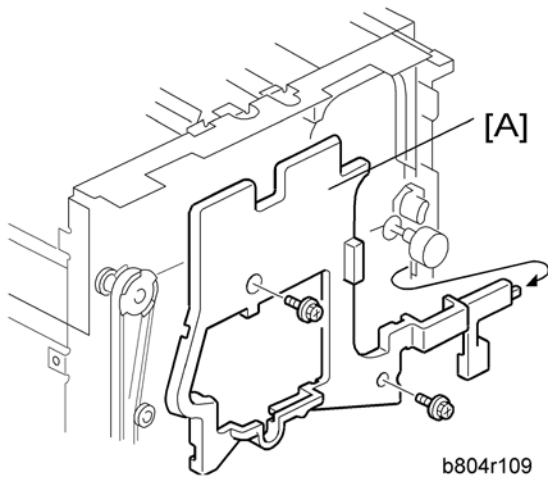

1. Rear cover, Upper covers, Front door, Cover, Paper exit cover (➔ "Exterior Cover")
2. Inner cover [A] (🔩 x2)

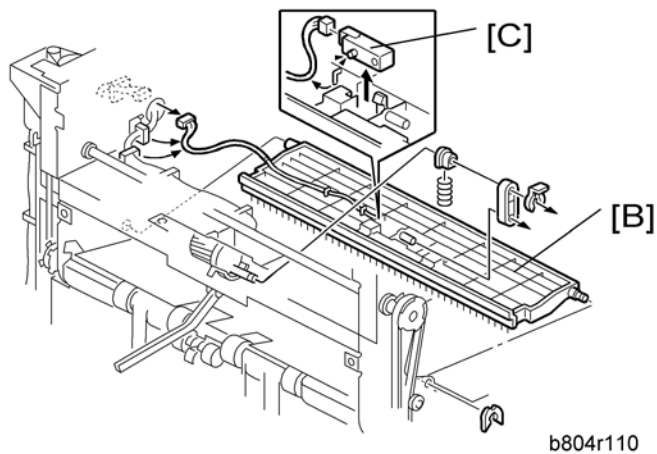

3. Exit guide plate [B] (🔩 x1, Link and spring, 🌀 x1, 🌀 x1)
4. Upper tray exit sensor [C] (S6) (🌀 x1)



## 1.2.6 PROOF TRAY FULL SENSOR

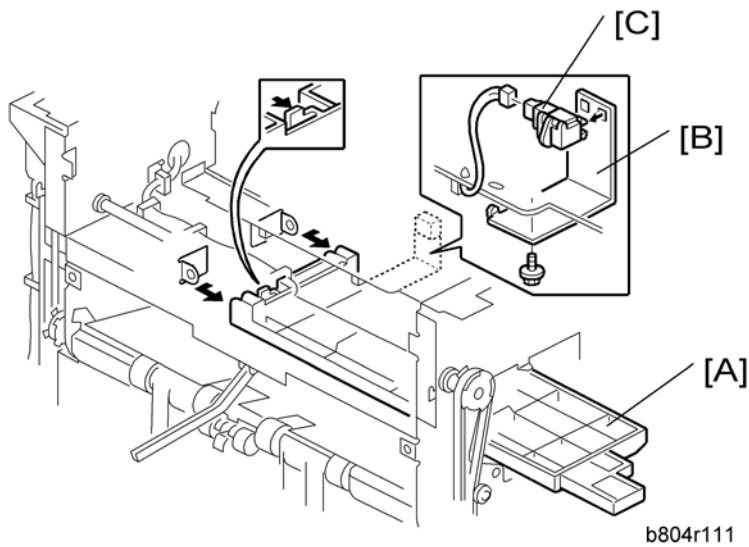

1. Exit guide plate. (➡ "Exit Guide Plate, Upper Tray Exit Sensor")
2. Guide plate [A] (hook x 2)
3. Sensor bracket [B] (🔩 x1)
4. Proof tray full sensor [C] (S11) (🔌 x1)

## 1.2.7 FINISHER ENTRANCE SENSOR

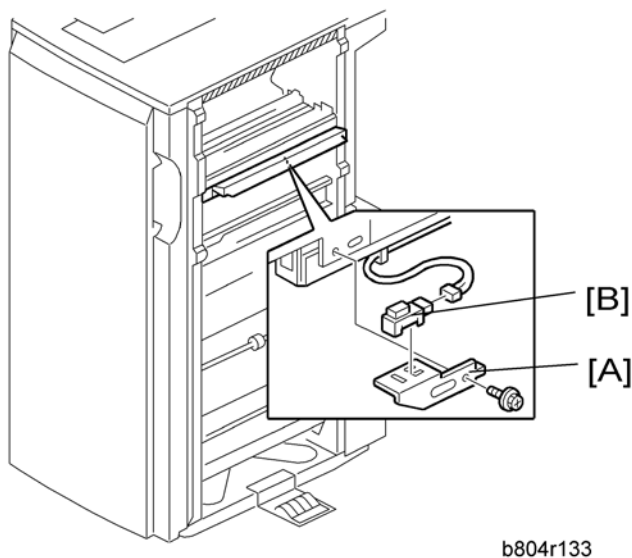

1. Disconnect the finisher if it is connected to the copier.
2. Sensor bracket [A] (🔩 x1)
3. Finisher entrance sensor [B] (S1) (🔌 x1)

Booklet Finisher  
 & Finishers  
 (B803/B805/  
 D373/D374/  
 D636/D637)

## 1.2.8 PRE-STACK TRAY EXIT SENSOR

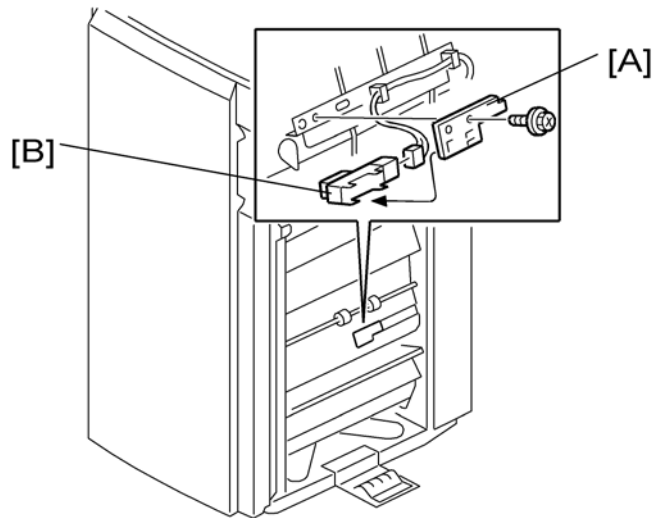

b804r102

1. Disconnect the finisher if it is connected to the copier.
2. Sensor bracket [A]
3. Pre-stack tray exit sensor [B] (S2)

## 1.3 STAPLER UNIT

### 1.3.1 CORNER STAPLER

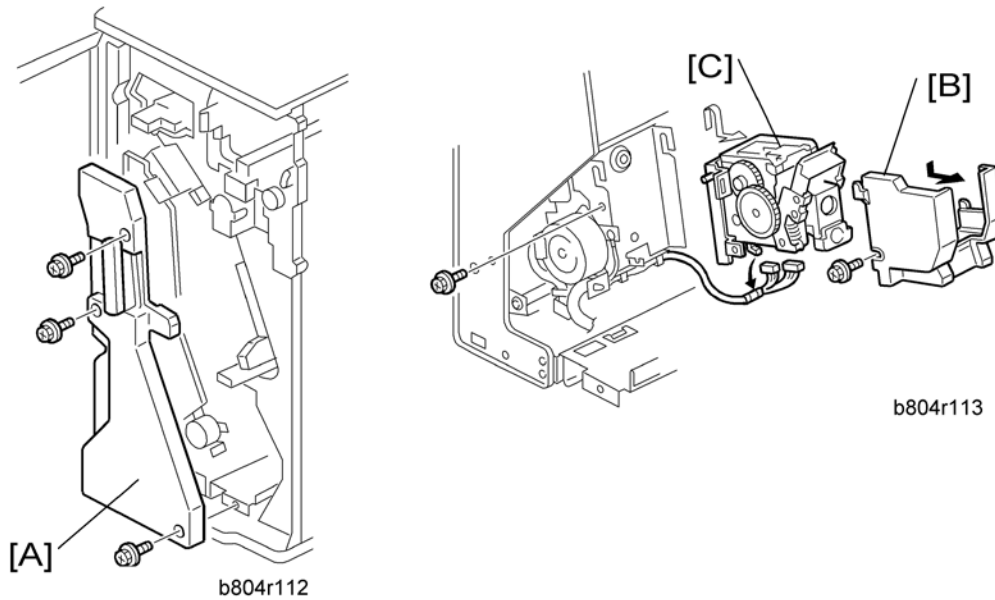

1. Open the front door.
2. Pull out the stapler unit.
3. Inner cover [A] (⚙️ x3)
4. Stapler unit holder [B] (⚙️ x1)
5. Corner stapler [C] (M20) (⚙️ x1)

Booklet Finisher  
& Finishers  
(B803/B805/  
D373/D374/  
D636/D637)

### 1.3.2 POSITIONING ROLLER

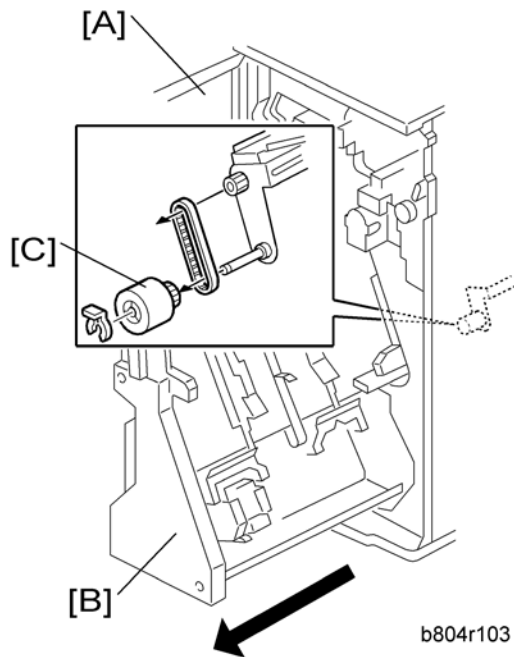

1. Open the front door [A].
2. Pull out the stapling unit [B].
3. Positioning roller [C] (⌚ x1, timing belt x1)

## 1.4 FOLD UNIT

### 1.4.1 FOLD UNIT

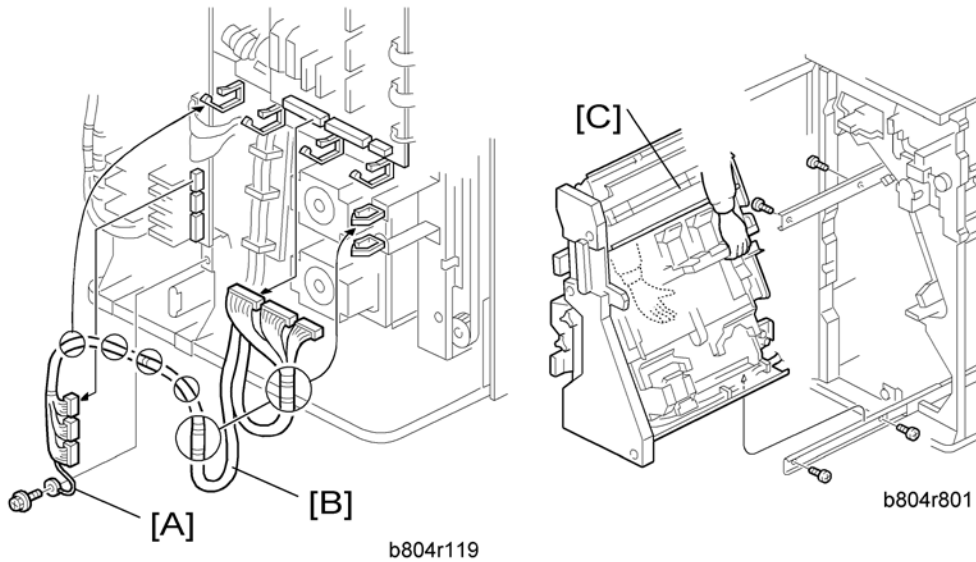

1. Remove the back cover (➔ "Exterior Covers").
2. Open the front door.

#### CAUTION

- The stapler unit is heavy.

3. Ground cable [A] (🔩 x1)
4. Harness [B] (🔩 x6, 📌 x6)
5. Stapler unit [C] (🔩 x4)

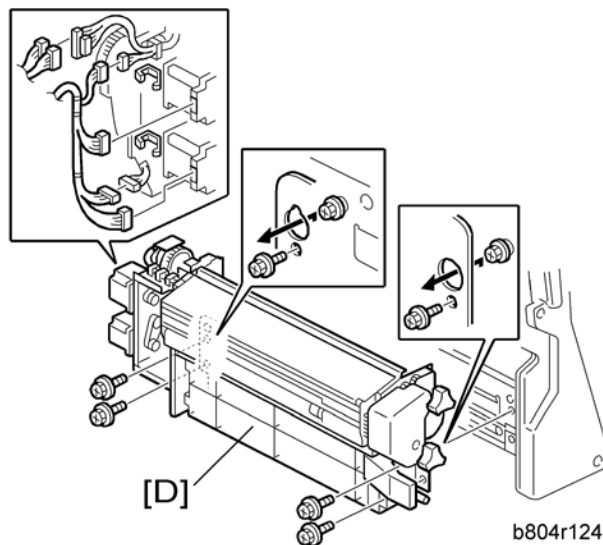

Booklet Finisher  
 & Finishers  
 (B803/B805/  
 D373/D374/  
 D636/D637)

**★ Important**

- Support the fold unit with your hand to prevent it from falling.

**⚠ CAUTION**

- The fold unit is heavy.

6. Folding unit [D] (🔩 x4, 🛠️ x2, 📏 x6)

**If you have replaced the folding unit:**

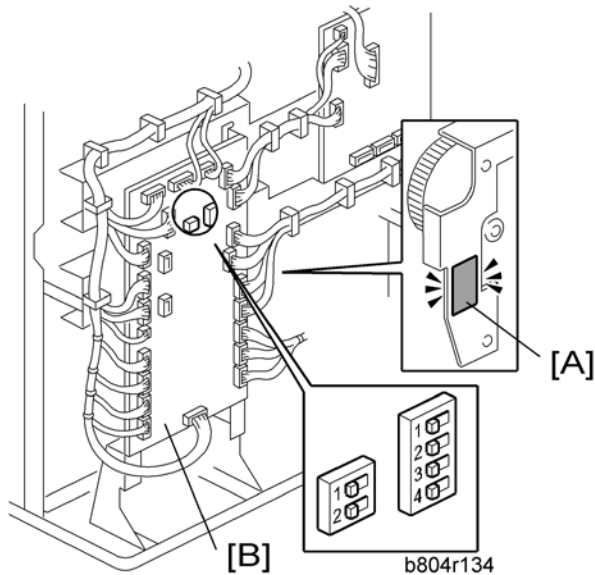

1. Read the DIP SW settings on the decal [A] attached to the back of the new folding unit.
2. Check the DIP SW settings on the main board [B] of the finisher.
3. If these settings are different, change these settings to match the settings printed on the decal attached to the folding unit.

**↓ Note**

- Set DIP switches 1 to 4 (the switch set on the right). Do not touch the other DIP switches.

## 1.4.2 FOLD UNIT ENTRANCE SENSOR

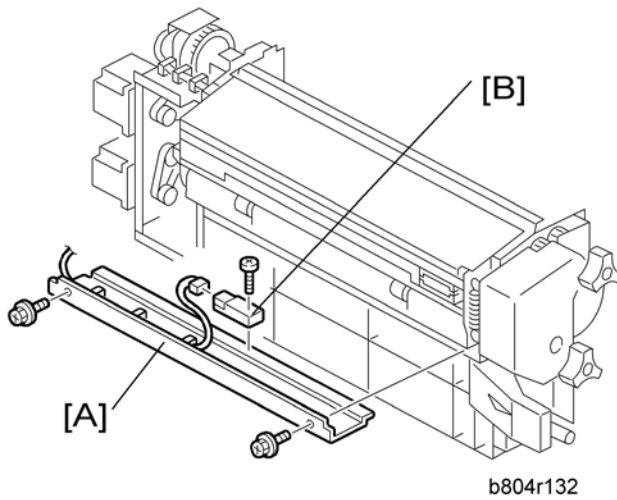

1. Pull out the stapler unit (➡ "Positioning Roller").
2. Fold unit entrance sensor bracket [A] (🔩 x2)
3. Fold unit entrance sensor [B] (S26) (🔩 x1, 📄 x1)

Booklet Finisher  
& Finishers  
(B803/B805/  
D373/D374/  
D636/D637)

### 1.4.3 FOLD UNIT EXIT SENSOR

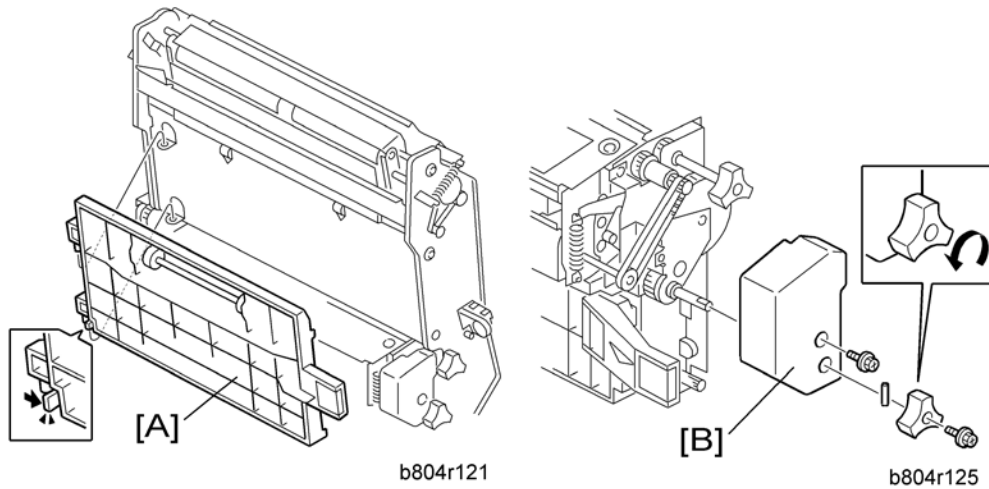

1. Open the front door.
2. Pull out the stapler unit (➡ "Positioning Roller").
3. Fold unit vertical guide plate [A]
4. Fold unit inner cover [B] (⚙️ x2, Spring pin x1)

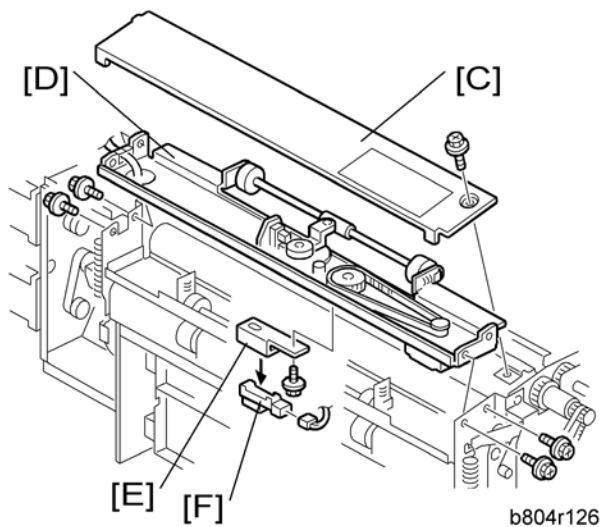

5. Fold unit upper cover [C] (⚙️ x1)
6. Paper clamp mechanism [D] (⚙️ x4)
7. Fold unit exit sensor bracket [E] (⚙️ x1)
8. Fold unit exit sensor [F] (S31) (⚙️ x1)



## 1.4.4 STACK PRESENT SENSOR

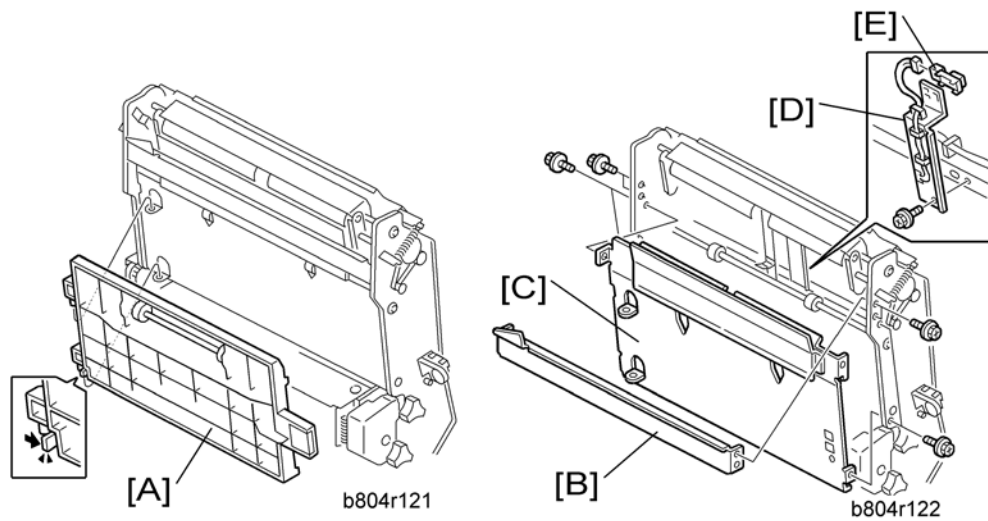

### ★ Important

- If you intend to correct the horizontal and vertical skew for the fold unit at the same time, do those adjustments first, then replace the sensor. (➔ "Folding Horizontal Skew Adjustment" or "Fold Vertical Skew Adjustment")

1. Remove the stapler unit (➔ "Fold Unit")
2. Guide plate [A].
3. Stay [B] (⚙️ x4)
4. Left plate [C] (⚙️ x4)
5. Sensor bracket [D] (⚙️ x1)
6. Stack present sensor [E] (S32) (🔌 x1)

Booklet Finisher  
& Finishers  
(B803/B805/  
D373/D374/  
D636/D637)

## 1.4.5 FOLDING HORIZONTAL SKEW ADJUSTMENT (FOR B804 ONLY)

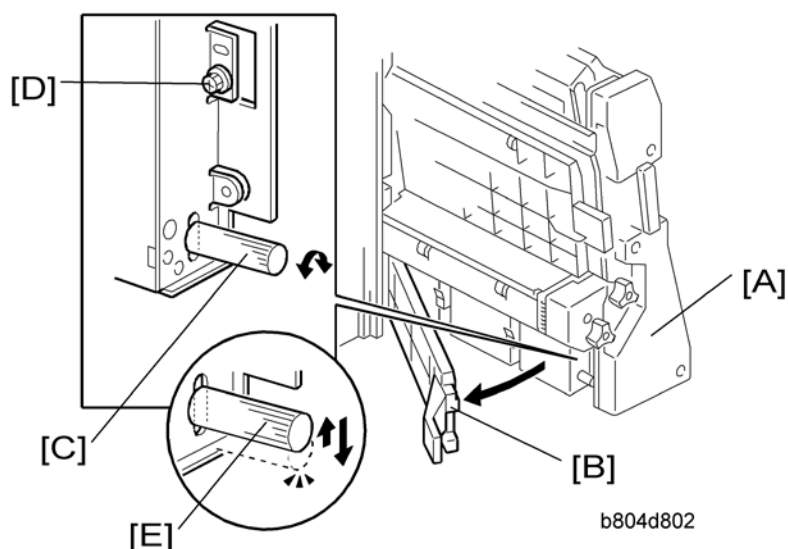

### ★ Important

- The fold unit is adjusted for optimum performance before the finisher is shipped from the factory. Do this adjustment only if the edges of folded booklets are not even.

1. Switch the copier on and enter the SP mode.
2. Europe, Asia: Use **SP6-134-001** (this is for A3 paper). North America: Use **SP6-134-005** (this is for DLT paper).

### ↓ Note

- If the original setting of SP6-134-001 or -005 is not "0", then you must do the vertical skew adjustment (➡ "Fold Vertical Skew Adjustment") after you finish this horizontal skew procedure.
3. Use the 10-key pad to input "-2" (mm) for the SP value. (Press  to enter the minus sign.)
  4. Press [#] then exit the SP mode.
  5. Open the front door and pull the stapler unit [A] out of the finisher.
  6. Open the guide plate [B].
  7. Loosen the adjustment screw [C] and then tighten until it stops. (Do not over tighten.)
  8. Remove the lock screw [D].
  9. Raise the tip [E] of the adjustment screw very slightly and allow it to descend under its own weight.

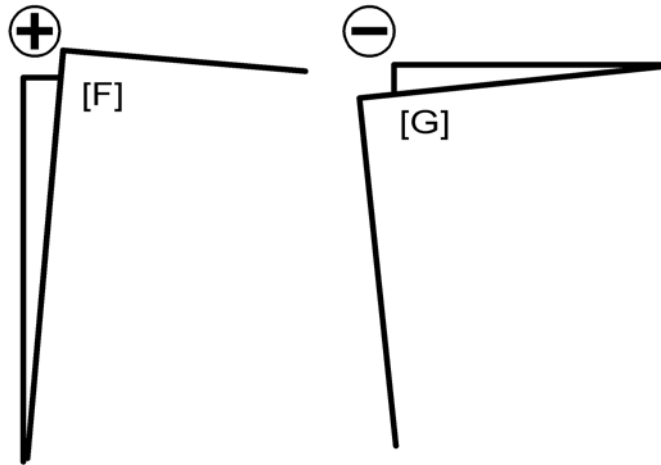

b804r901

10. Push the stapler unit into the finisher and close the front door.
11. Do a folding test.
  - Switch the copier on.
  - Put one page of A3 or DLT paper in the ARDF.
  - On the copier operation panel, select booklet stapling.
  - Press [Start]. One sheet is folded.
12. Remove the sheet from the lower tray.
13. Hold the folded sheet with the creased side pointing down and face-up (the same way that it came out of the finisher).
14. Referring to the diagram, determine if the skew is + [F] or - [G].

Booklet Finisher  
 & Finishers  
 (B803/B805/  
 D373/D374/  
 D636/D637)

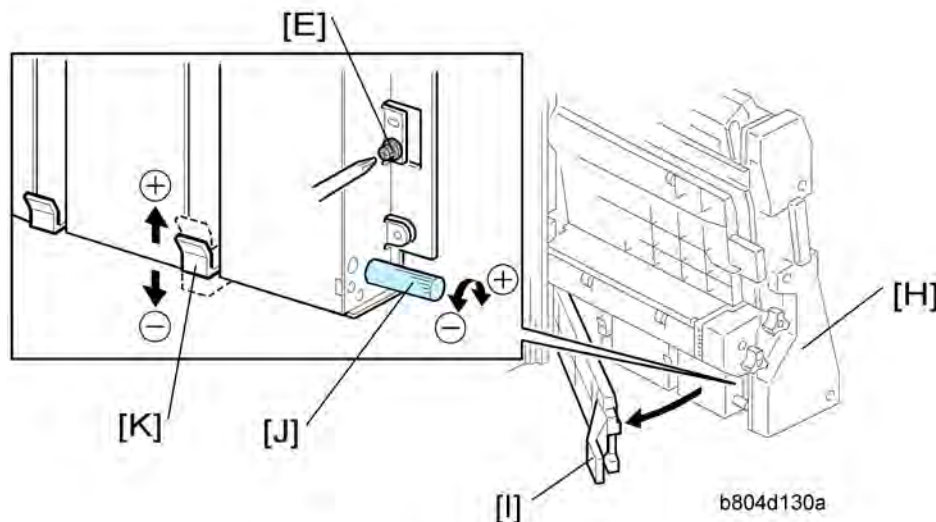

15. Open the front door of the finisher and pull the stapler unit [H] out.
16. Open the guide plate [I].
17. Turn the adjustment screw [J] to correct the amount of skew you measured from the test sheet.
  - For + skew [F], turn the adjustment screw (clockwise).

## Fold Unit

- For – skew [G], turn the adjustment screw to the left (counter-clockwise).
  - Every click in the +/- direction adjusts the fold position by 0.1 mm by moving the bottom fence [K].
18. Raise the tip of the adjustment screw [J] and allow it to lower under its own weight.
  19. Attach and tighten the lock screw [L].
  20. Push the stapler unit into the machine, close the front door, then turn the copier on.
  21. Europe, Asia: Do **SP6-134-001** (this is for A3 paper). North America: **Do SP6-134-005** (this is for DLT paper).
  22. Reset it to "0".
  23. Do the test again.
  24. If the result is satisfactory, this completes the adjustment. -or- If some skew remains, repeat this adjustment.

### Note

- After doing this adjustment, adjust for vertical skew, if necessary. (➡ "Fold Vertical Skew Adjustment")

## 1.4.6 FOLD VERTICAL SKEW ADJUSTMENT (FOR B804 ONLY)

### ★ Important

- The fold unit is adjusted for optimum performance before the finisher is shipped from the factory. Do this adjustment only if the edges of folded booklets are not even.
1. Switch the copier on.
  2. Do a folding test.
    - Switch the copier on.
    - Put one page of A3 or DLT paper in the ARDF.
    - On the copier operation panel, select booklet stapling.
    - Press [Start]. One sheet is folded.
  3. Hold the folded sheet with the creased side pointing down, and face-up (the same way that it came out of the finisher).

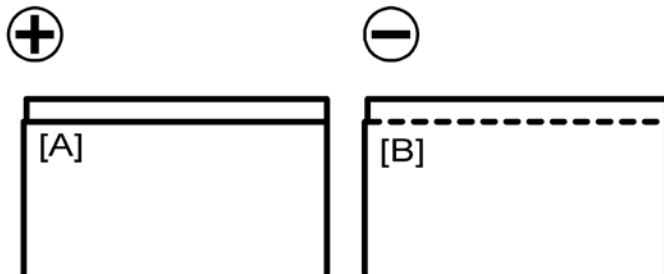

b804r902

4. Referring to the diagram, determine if the skew is positive [A] or negative [B].
5. Measure the amount of skew.
6. Enter the SP mode
  - Europe, Asia: Use **SP6-134-001** (this is for A3 paper).
  - North America: Use **SP6-134-005** (this is for DLT paper).
7. Enter one-half the measured amount of skew. Example: If the measure amount of skew is -1.2 mm, enter -0.6 mm

Booklet Finisher  
 & Finishers  
 (B803/B805/  
 D373/D374/  
 D636/D637)

## Fold Unit

↓ Note

- The range for measurement is  $-3.0$  mm to  $+3.0$  mm in  $0.2$  mm steps for every notch adjustment.
8. Exit the SP mode and do the test again (steps 2 to 5).
  9. Repeat this procedure until the skew is corrected.

The illustration below shows the effects of +/- adjustment with SP6113. (The vertical arrows show the direction of paper feed.)

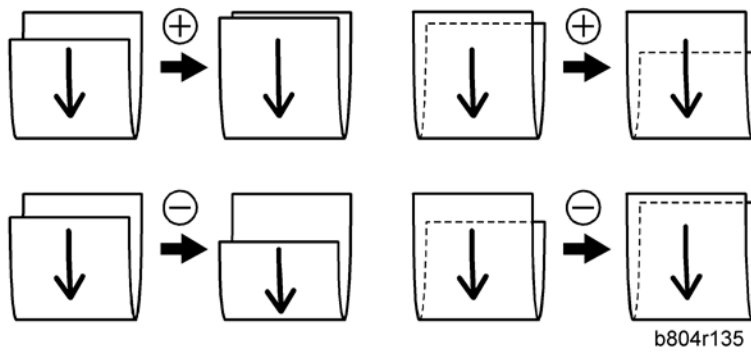

## 1.5 BOOKLET STAPLER UNIT

### 1.5.1 BOOKLET STAPLER

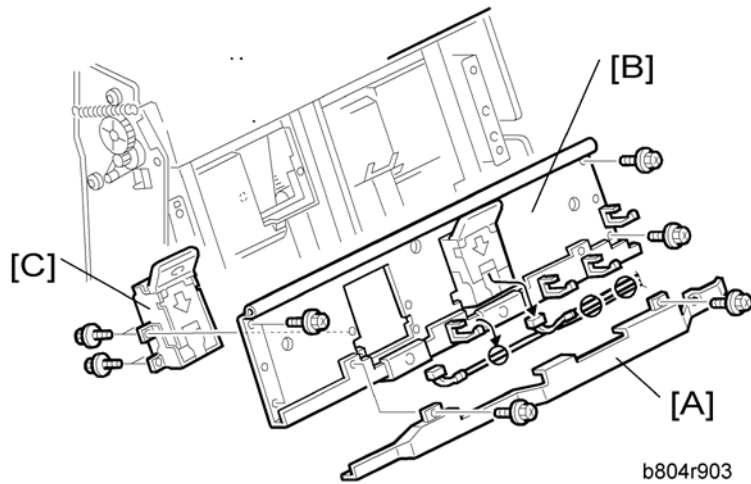

1. Open the front door.
2. Pull out the stapler unit (→ "Positioning Roller").
3. Harness cover [A] (⌘ x2)
4. Booklet stapler support stay [B] (⌘ x4, ⌘ x2, ⌘ x4)
5. Stapler [C] (⌘ x4)

Booklet Finisher  
 & Finishers  
 (B803/B805/  
 D373/D374/  
 D636/D637)

## 1.5.2 BOOKLET STAPLER MOTOR

1. Open the front door.
2. Remove the stapler unit. (→ "Fold Unit")

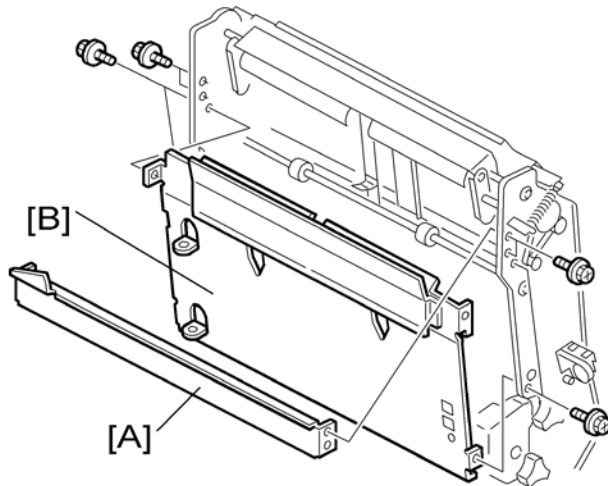

b804r122a

3. Stay [A] (⚙ x4).
4. Left plate [B] (⚙ x4)

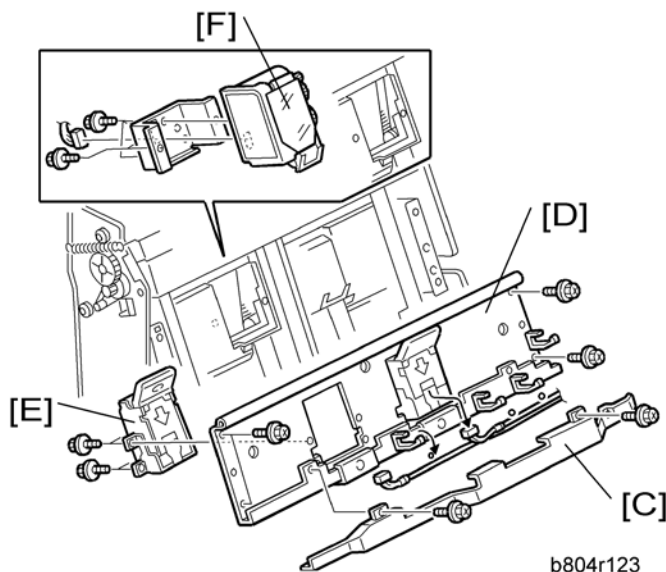

b804r123

5. Harness cover [C] (⚙ x2)
6. Booklet stapler support stay [D] (⚙ x4, ⚙ x2, ⚙ x4)
7. Booklet stapler [E] (⚙ x4)
8. Booklet stapler motor [F] (⚙ x2, ⚙ x1)



## To Reattach the Booklet Stapler Motor

1. Reattach the booklet stapler motor.



- Do not tighten the screws.

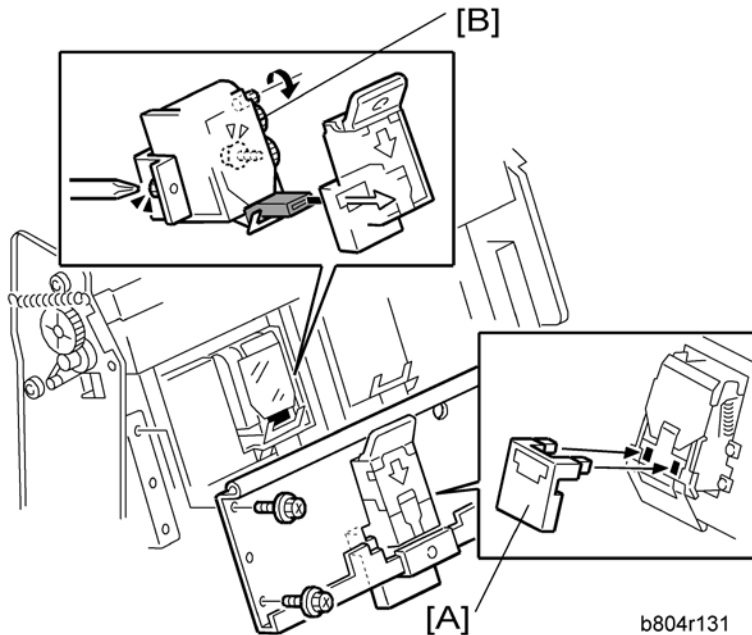

2. Attach the special tool [A] and reattach the booklet stapler stay.



- This tool is included with the stapler spare part.
3. Turn the gear [B] with your finger until it stops.
  4. Tighten the screws to attach to the booklet stapler motor.
  5. Remove the stay again and remove the special tool.
  6. Reattach the booklet stapler stay.
  7. Push the stapler unit into the machine.

Booklet Finisher  
& Finishers  
(B803/B805/  
D373/D374/  
D636/D637)

## 2. DETAILED SECTION DESCRIPTIONS

### 2.1 COMPONENT LAYOUT

#### 2.1.1 GENERAL LAYOUT

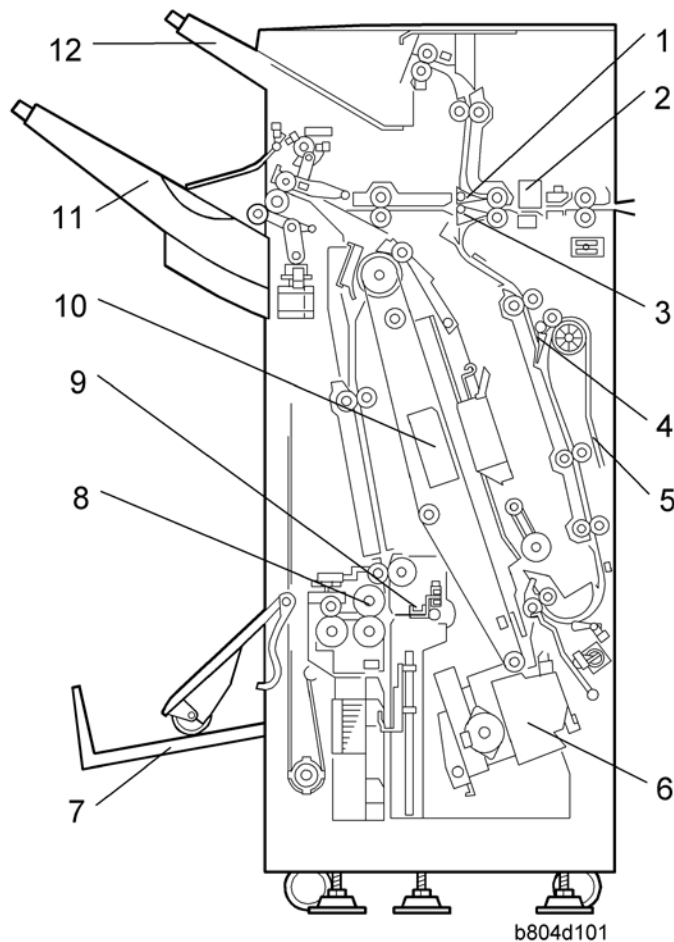

1. Proof Tray Junction Gate	7. Lower Tray (Booklet)* <sup>1</sup>
2. Punch Unit	8. Folder Rollers* <sup>1</sup>
3. Stapler Junction Gate	9. Folder Plate* <sup>1</sup>
4. Pre-Stack Junction Gate	10. Booklet Stapler* <sup>1</sup>
5. Pre-Stack Tray	11. Upper Tray (Shift)
6. Corner Stapler (M20)	12. Proof Tray

\*<sup>1</sup>: B804 Only

#### ***Paper direction***

The operation of the proof tray and stapler junction gates direct the flow of the paper once it enters

the finisher:

<b>Proof Junction Gate</b>	<b>Stapler Junction Gate</b>	<b>Paper Feeds</b>
Closed	Closed	Paper feeds straight through
<b>Open</b>	Closed	Paper feeds to the proof tray
Closed	<b>Open</b>	Paper feeds to the staple tray

### ***Proof tray***

Copies are sent to the proof tray (12) when neither sorting nor stapling are selected for the job.

### ***Upper tray***

The upper tray (11) receives copies that are sorted and shifted and also receives copies that have been corner stapled. Corner stapling is provided on both the B804 and the B805.

### ***Pre-stack tray***

The pre-stack tray has a switchback mechanism to increase the productivity of stapling. (➡ "Pre-Stacking) Pre-stacking is done for corner stapling in the B804/B805 and for booklet stapling in the B804.

### ***Lower tray***

The lower tray (7) receives copies that have been center folded and stapled (booklet stapling). Booklet stapling is not provided on the B805.

Booklet Finisher  
& Finishers  
(B803/B805/  
D373/D374/  
D636/D637)

## 2.1.2 ELECTRICAL COMPONENTS

### Upper Area B804/B805

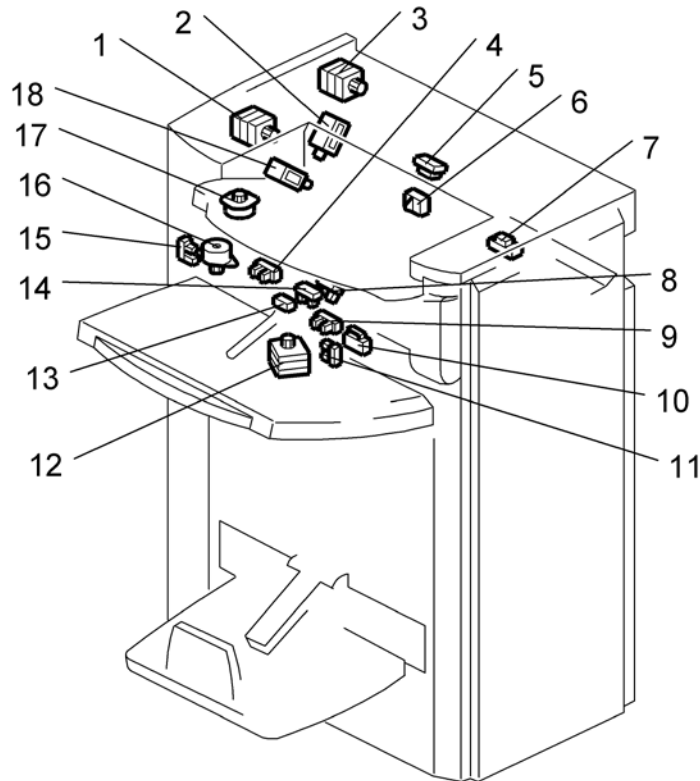

b804d201

1. Upper/Proof Exit Motor (M4)	10. Upper Tray Limit Switch (SW2)
2. Stapling Tray Junction Gate Solenoid (SOL2)	11. Stacking Roller HP Sensor (S13)
3. Upper Transport Motor (M2)	12. Stacking Sponge Roller Motor (M10)
4. Exit Guide Plate HP Sensor (S7)	13. Upper Tray Exit Sensor (S6)
5. Proof Tray Exit Sensor (S10)	14. Upper Tray Paper Height Sensor (S8) (Staple Mode)
6. Proof Tray Full Sensor (S11)	15. Shift Roller HP Sensor (S5)
7. Finisher Entrance Sensor (S1)	16. Shift Roller Motor (M18)
8. Upper Tray Paper Height Sensor (S9) (Non-Staple Mode)	17. Exit Guide Plate Motor (M19)
9. Upper Tray Limit Sensor (S12)	18. Proof Junction Gate Solenoid (SOL1)

**Lower Area B804/B805**

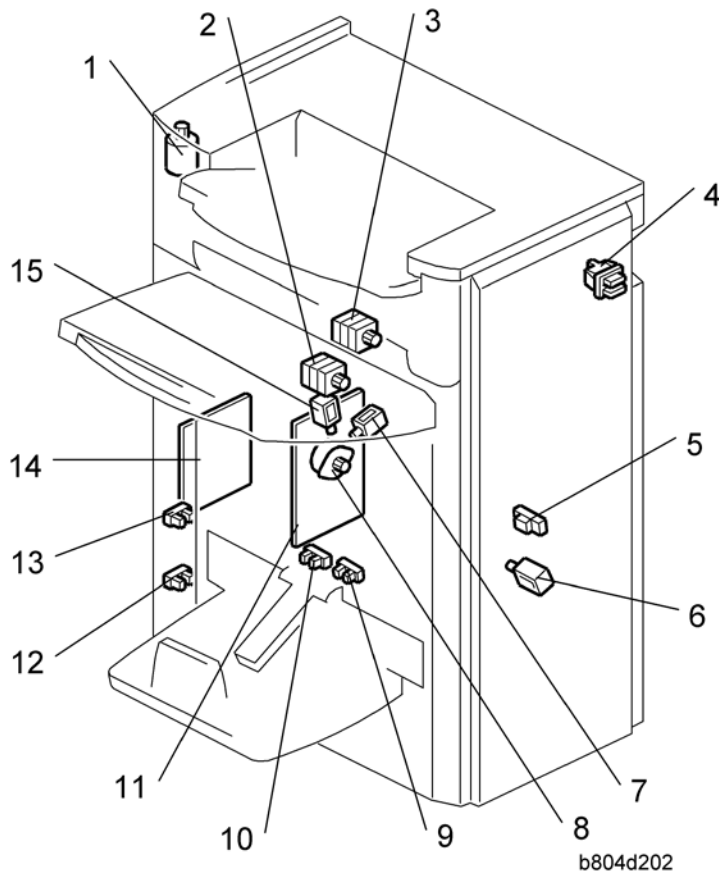

Booklet Finisher  
& Finishers  
(B803/B805/  
D373/D374/  
D636/D637)

- |  |   |
|--|---|
| <ul style="list-style-type: none"> <li>1. Upper Tray Lift Motor (M21)</li> <li>2. Lower Transport Motor (M3)</li> <li>3. Entrance Motor (M1)</li> <li>4. Front Door Safety Switch (SW1)</li> <li>5. Pre-Stack Tray Exit Sensor (S2)</li> <li>6. Stapling Edge Pressure Plate Solenoid (SOL4)</li> <li>7. Positioning Roller Solenoid (SOL3)</li> </ul> | <ul style="list-style-type: none"> <li>8. Positioning Roller Motor (M14)</li> <li>9. Lower Tray Full Sensor – Front (S34)<sup>*1</sup></li> <li>10. Lower Tray Full Sensor – Rear (S33)<sup>*1</sup></li> <li>11. Main Board (PCB1)</li> <li>12. Upper Tray Full Sensor – (S20) <sup>*2</sup></li> <li>13. Upper Tray Full Sensor – (S19)</li> <li>14. Booklet Stapler Board (PCB2)<sup>*1</sup></li> <li>15. Booklet Pressure Roller Solenoid – (SOL5)<sup>*1</sup></li> </ul> |
|--|---|

<sup>\*1</sup>: B804 Only, <sup>\*2</sup>: B805 Only

**Punch Unit B702**

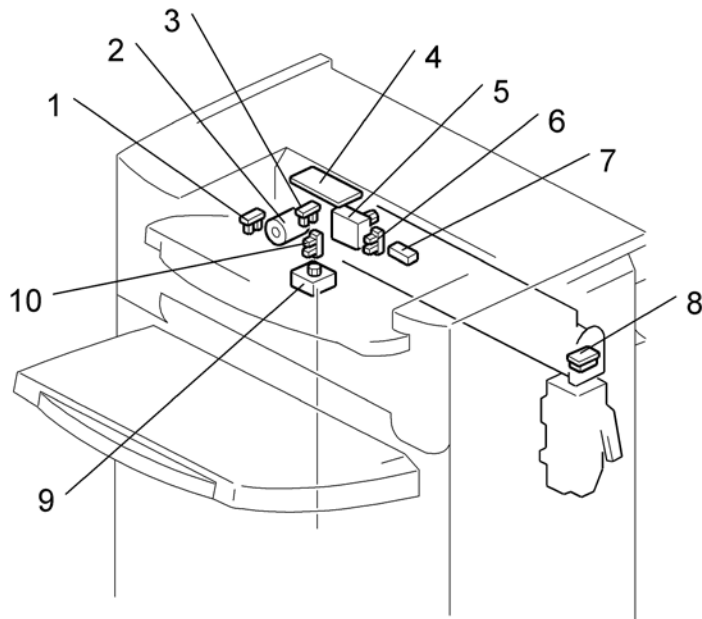

b804d203a

1. Punch Encoder Sensor (S24)	6. Paper Position Slide HP Sensor (S22)
2. Punch Drive Motor (M24)	7. Paper Position Sensor (S3)
3. Punch HP Sensor (S24)	8. Punch Hopper Full Sensor (S4)
4. Punch Unit Board (PCB3)	9. Punch Movement Motor (M9)
5. Paper position sensor slide motor (M7)	10. Punch Movement HP Sensor (S21)

**Stacker/Stapler - B804/B805**

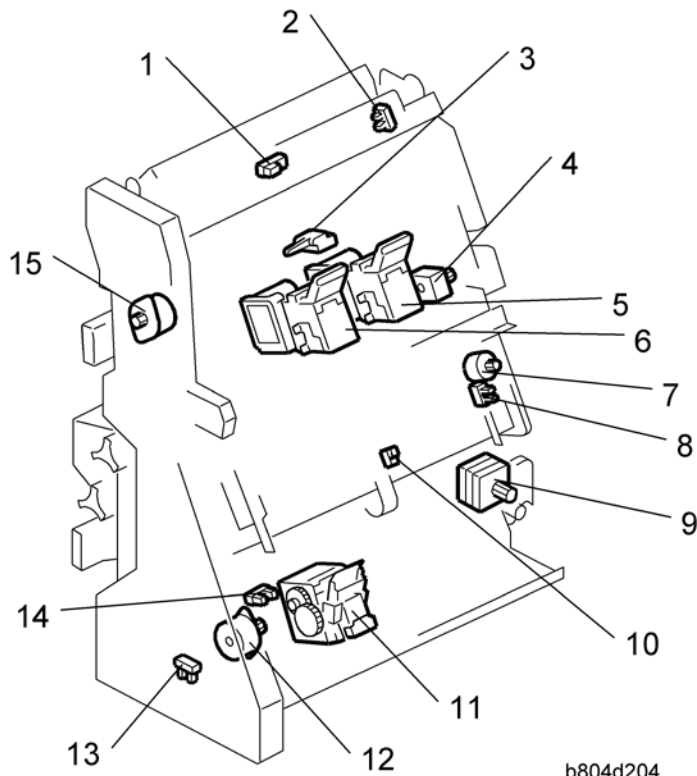

b804d204

**Booklet Finisher  
& Finishers  
(B803/B805/  
D373/D374/  
D636/D637)**

<p>1. Stack Present Sensor (S32)*<sup>1</sup></p> <p>2. Stack Junction Gate HP Sensor (S27)*<sup>1</sup></p> <p>3. Stack Feed Out Belt HP Sensor (S16)</p> <p>4. Feed Out Belt Motor (M5)</p> <p>5. Booklet Stapler EH185R – Rear (M23)*<sup>1</sup></p> <p>6. Booklet Stapler EH185R – Front (M22)*<sup>1</sup></p>	<p>7. Jogger Fence Motor (M15)</p> <p>8. Jogger Fence HP Sensor (S15)</p> <p>9. Corner Stapler Movement Motor (M6)</p> <p>10. Stapling Tray Paper Sensor (S14)</p> <p>11. Corner Stapler EH530 (M20)</p> <p>12. Corner Stapler Rotation Motor (M13)</p> <p>13. Corner Stapler HP Sensor (S17)</p> <p>14. Stapler Rotation HP Sensor (S18)</p> <p>15. Stack Junction Gate Motor (M17) *<sup>1</sup></p>
--	--

\*<sup>1</sup>: B804 Only

**B804 Fold unit**

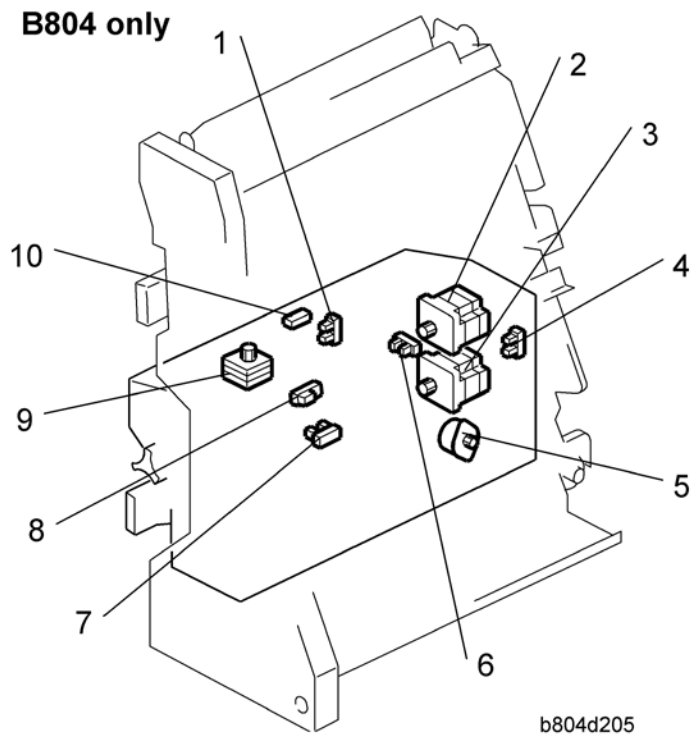

1. Clamp Roller HP Sensor (S25)

2. Fold Roller Motor (M12)

3. Fold Plate Motor (M11)

4. Fold Plate HP Sensor (S29)

5. Fold Unit Bottom Fence Lift Motor (M16)

6. Fold Cam HP Sensor (S30)

7. Fold Bottom Fence HP Sensor (S28)

8. Fold Unit Entrance Sensor (S26)

9. Clamp Roller Retraction Motor (M8)

10. Fold Unit Exit Sensor (S31)



### 2.1.3 SUMMARY OF ELECTRICAL COMPONENTS

Here is a general summary of all the electrical components of the B804/B805 finishers.



- In the table below a number that appears in bold text (**M8**, etc.) denotes a component that is on the 2000/3000 Sheet Finisher B804 only.

No.	Component	Function
<b>Boards (PCB)</b>		
PCB1	Main Board	The main board that controls the finisher
PCB2	Booklet Stapler Board	A separate board that controls booklet finishing.
PCB3	Punch Unit Board	The board that controls the punch unit.
<b>Motors</b>		
M1	Finisher Entrance Motor	Drives 1) the finisher entrance rollers, 2) and the punch waste transport belt of the punch unit.
M2	Upper Transport Motor	Drives the paper feed rollers that feed paper 1) to the proof tray, 2) straight-through to the upper tray, 3) the pre-stack tray entrance roller.
M3	Lower Transport Motor	Drives paper feed rollers forward and reverse in the pre-stack tray for the switchback, and drives the other rollers in the lower transport area.
M4	Upper/Proof Tray Exit Motor	Drives 1) proof tray exit rollers, 2) extension and retraction of the stacking sponge roller, 3) upper tray exit rollers.
M5	Feed Out Belt Motor	Drives the feed out belt that moves the stapled stacks out of the stapling tray after stapling.
M6	Corner Stapler Movement Motor	Moves the corner stapler horizontally on a steel rod to position the stapler at the stapling position at 1) the front, 2) the rear (straight stapling), 3) the rear (diagonal stapling), or 4) the front and rear for double stapling.

Booklet Finisher  
 & Finishers  
 (B803/B805/  
 D373/D374/  
 D636/D637)

Component Layout

No.	Component	Function
M7	Paper Position Sensor Slide Motor	Drives the movement of the paper position slide that holds the paper position sensor (S3) that detects the position of the paper.
<b>M8</b>	Clamp Roller Retraction Motor	Drives a large cam that alternately clamps and unclamps the clamp retraction roller, the idle roller of the clamp roller pair. When these rollers are clamped, they are part of the paper feed path and feed the stack toward the bottom fence of the fold unit. When the idle roller is retracted, the stacks falls a very short distance (3 mm) onto the fold unit bottom fence below. These rollers remain unclamped while the bottom fence positions the stack for folding and while the stack is folded by the fold rollers.
M9	Punch Movement Motor	Drives the front/back movement of the punch unit to position it correctly for stapling the paper below.
M10	Stacking Sponge Roller Motor	Rotates the stacking roller that drags each sheet back against the end fence to jog the bottom of each sheet after feed out to the upper tray.
<b>M11</b>	Fold Plate Motor	Drives the fold plate that pushes the center of the stack into the nip of the fold rollers to start the fold.
<b>M12</b>	Fold Roller Motor	Rotates forward and drives the fold rollers that fold the stack and feed it out of the fold unit, reverses to feed the fold once more into the fold unit, and then rotates forward again to feed the fold out of the fold unit.
M13	Corner Stapler Rotation Motor	Swivels the corner stapler and positions it so the staple fires at an oblique angle at the rear corner of the paper stack.
M14	Positioning Roller Motor	Drives the positioning roller in the stapling tray.
M15	Jogger Fence Motor	Drives the jogger fences in the stapling tray to jog both sides of the stack before stapling.

No.	Component	Function
<b>M16</b>	Fold Unit Bottom Fence Lift Motor	Raises the bottom fence and stops when the center of the vertical stack is opposite the edge of the horizontal fold blade. The distance for raising the blade is prescribed as one-half the size of the paper selected for the job. For large paper, (A3, B4) the bottom fence first lowers the stack 10 mm below the fold position, and then raises it to the fold position.
<b>M17</b>	Stack Junction Gate Motor	Drives the large cam that operates the stack junction gate at the top of the stapling tray. When this gate is open, it directs the ascending stack to the upper tray if it has been corner stapled, or if it is closed the gate turns the booklet stapled stack down so it falls onto the bottom fence of the folding unit.
M18	Shift Roller Motor	Drives the shift roller that operates in shift mode to stagger document sets as they feed out to the upper tray (making them easier to separate).
M19	Exit Guide Plate Motor	Drives the mechanism that raises and lowers the exit guide plate.
M20	Corner Stapler EH530	This is the roving corner stapler, mounted on a steel rail that staples 1) at the front, 2) at the rear (straight staple), 3) at the rear (diagonal staple), and 4) front and rear (two staples).
M21	Upper Tray Lift Motor	Raises and lowers the upper tray during feed out to keep the tray at the optimum height until it is full.
<b>M22</b>	Booklet Stapler EH185R: Front	Booklet stapler. Staples paper stacks in the center before they are folded.
<b>M23</b>	Booklet Stapler EH185R: Rear	Booklet stapler. Staples paper stacks in the center before they are folded.
M24	Punch Drive Motor	Fires the punches that punch the holes in the paper.

Booklet Finisher  
 & Finishers  
 (B803/B805/  
 D373/D374/  
 D636/D637)

No.	Component	Function
<b>Sensors</b>		
S1	Finisher Entrance Sensor	Provides two functions: (1) Detects paper entering the finisher from the copier, and (2) Signals a jam if it detects paper at the entrance when the copier is switched on.
S2	Pre-stack Tray Exit Sensor	Detects 1) paper fed from the pre-stack tray to the stapling tray, and detects 2) paper in the pre-stack when the copier is switched on. (This sensor performs no timing function. The entire flow of paper through the pre-stacking mechanism is controlled by motor pulse counts.)
S3	Paper Position Sensor	The photosensor that detects the edge of the paper and sends this information to the punch unit board where it is used to position the punch for punching the holes in the paper.
S4	Punch Hopper Full Sensor	1) A photosensor that detects and signals that the punch hopper is filled with punch waste and needs emptying, and 2) confirms the presence of the punch hopper and signals an error if it is missing or not installed completely.
S5	Shift Roller HP Sensor	Located near the shift roller motor, controls the front-to-back movement of the shift roller as shifts paper during straight-through feed.
S6	Upper Tray Exit Sensor	A flat, photo sensor located inside the guide plate, detects the leading edge and trailing edge of the paper as it feeds out to the upper tray during straight-through jobs (with and without stapling). When paper is fed to the upper tray, at the paper output slot this sensor signals an error when it detects (1) paper has failed to leave the paper exit (lag error), (2) detects paper has failed to arrive at the paper exit (late error), (3) detects paper is in the exit slot when the machine is turned on.

No.	Component	Function
S7	Exit Guide Plate HP Sensor	Controls the vertical movement of the control exit guide . The guide plate is in the home position when the guide plate is down and the actuator interrupts the sensor gap.
S8	Upper Tray Paper Height Sensor (Staple Mode)	This is the upper sensor of the upper/lower paper height sensor pair that controls the lift of the upper tray. This sensor detects the paper height of the stack in the upper tray when the copier is operating in the staple mode.
S9	Upper Tray Paper Height Sensor (Non-Staple Mode)	This is the lower sensor of the upper/lower paper height sensor pair that controls the lift of the upper tray. When the machine is switched on, the upper tray rises until the actuator on the tray triggers this sensor to switch off the upper tray lift motor.
S10	Proof Tray Exit Sensor	This sensor detects and times the feeding of paper to the proof tray. It also detects whether paper is present at the proof tray exit when the copier is switched on.
S11	Proof Tray Full Sensor	The top of the stack in the proof tray increases until it nudges the feeler of this sensor. The sensor then signals that the proof tray is full and the job halts until some paper is removed from the proof tray.
S12	Upper Tray Limit Sensor	<p>This sensor controls the position of the upper tray 1) during straight-through feed out, 2) during shift feed out, 3) when the machine is turned on. The machine obeys the signal of whichever sensor is actuated first.</p> <p>An actuator attached to an arm triggers this sensor. The tip of the same arm depresses the upper tray limit switch. If the sensor fails, the tip of the arm will activate the upper tray limit microswitch (SW2) and stop the lift of the upper tray.</p> <p><b>Note:</b> When the machine is turned on, the upper tray position is controlled by either this sensor or the upper tray paper height sensor (S9).</p>

## Component Layout

No.	Component	Function
S13	Stacking Roller HP Sensor	Controls the forward and back motion of the stacking roller (a sponge roller) located at the output slot of the upper tray. The sponge roller drags each ejected sheet back against the end fence of the upper tray to keep the bottom of the stack aligned.
S14	Stapling Tray Paper Sensor	A photo sensor that detects whether paper is in the stapling tray. When this sensor detects paper, the bottom fence motor raises or lowers the bottom fence to position the selected paper size for booklet stapling.
S15	Jogger Fence HP Sensor	Detects the home position of the jogger fences. When the actuator on the jogger fence interrupts this sensor, the jogger fence is in its home position and the jogger fence motor (M15) stops.
S16	Stack Feed-Out Belt HP Sensor	Controls the position of the stack feed-out pawl on the stack feed-out belt. Once the actuator on the feed belt nudges the feeler of this sensor near the top of the stapling unit, the feed out belt motor (M5) remains on for the time prescribed to position the pawl at the home position to catch the next stack.
S17	Corner Stapler HP Sensor	Located at the front the stapling tray and mounted above the steel rod where the corner stapler travels, this sensor detects the home position of the corner stapler. The corner stapler is in its home position when the actuator on the corner stapler unit interrupts this sensor.
S18	Stapler Rotation HP Sensor	Controls the angle of the position of the corner stapler during oblique stapling.

No.	Component	Function
S19	Upper Tray Full Sensor (B804/B805)	<p><b>B804:</b> When the actuator on the side of the upper fence enters the gap of this sensor, the sensor signals that the upper tray is at its lowest position (full) and stops the job.</p> <p><b>B805:</b> One of two upper tray full sensors. This is the higher tray full sensor for A3 and other heavy paper. The other upper tray full sensor (20) is for lighter paper.</p>
S20	Upper Tray Full Sensor (B805 only)	<p><b>B804:</b> This sensor is not used on the booklet finisher. There is only one upper tray full sensor (S18).</p> <p><b>B805:</b> One of two upper tray full sensors. This is the lower tray full sensor for A4 and smaller paper. The other upper tray full sensor (19) is for larger paper.</p>
S21	Punch Unit HP Sensor	Switches off the punch movement motor when the punch unit returns to its home position. Pulse counts determine where the punch unit pauses for punching and reversing.
S22	Paper Position Side HP Sensor	Controls the movement of the paper position detection unit. Switches on when the horizontal detection unit is at the home position (HP is the reference point).
S23	Punch HP Sensor	Detects the home position of the punch unit and controls the vertical movement of the punches when they fire.
S24	Punch Encoder Sensor	When the punch mode is selected for the job (2-hole, 3-hole, etc.), the machine controls the operation of the punch drive (M24) motor which drives a small encoder shaped like a notched wheel. This wheel is rotated forward and reverse precisely to select which punches are moved up and down during the punch stroke.

## Component Layout

No.	Component	Function
<b>S25</b>	Clamp Roller HP Sensor	Controls the movement of the clamp retraction roller (the idle roller of the clamp roller pair).
<b>S26</b>	Fold Unit Entrance Sensor	Detects 1) the leading edge of the stack during booklet stapling, and 2) also used to signal an alarm if a paper is detected at the entrance of the fold unit when the copier is turned on.
<b>S27</b>	Stack Junction Gate HP Sensor	Controls the opening and closing of the stack junction gate. Switches on when the stack junction gate is open and at the home position.
<b>S28</b>	Fold Bottom Fence HP Sensor	Controls the movement of the bottom fence in the folding unit using pulse counts based on the size of the paper selected for the job to position the stack correctly for feeding.
<b>S29</b>	Fold Plate HP Sensor	Along with the fold plate cam HP sensor (S30) this sensor controls the movement of the fold plate . The fold plate has arrived at the home position when the edge of the plate enters the gap of this sensor.
<b>S30</b>	Fold Plate Cam HP Sensor	Along with the fold plate HP sensor (S29), this sensor controls the movement of the fold plate. The actuator mounted on the end of the roller that drives the folder plate forward and back makes three full rotations, i.e. the actuator passes the sensor gap twice and stops on the 3rd rotation and reverses. This accounts for the left and right movement of fold plate.
<b>S31</b>	Fold Unit Exit Sensor	1) Detects the folded edge of the stack as it feeds out from the nip of the fold rollers, stops the rollers, and reverses them so the fold feeds back into the nip, 2) when the folded booklet finally emerges from the nip of the fold rollers, detects the leading and trailing edge of the booklet to make sure that it feeds out correctly.



No.	Component	Function
S32	Stack Present Sensor	This sensor determines whether there is paper at the turn junction gate when the machine is turned on. If a stack is present, this triggers a jam alert. (This sensor performs no dynamic function such as pulse counting, etc. It only detects whether paper is at the top of the folding unit when power is turned on.)
S33	Lower Tray Full Sensor - Rear	This rear sensor is the lower sensor of the lower tray full sensor pair. Two actuators are attached to the actuator arm that touches the top of stapled and folded booklets as they feed out. The on/off combinations of the two sensors are used to detect when the tray is full and stop the job. (The lower tray is stationary. At tray full, the job halts until booklets are removed from the lower tray.)
S34	Lower Tray Full Sensor - Front	This front sensor is the higher sensor of the lower tray full sensor pair. Two actuators are attached to the actuator arm that touches the top of stapled and folded booklets as they feed out. The on/off combinations of the two sensors are used to detect when the tray is full and stop the job. (The lower tray is stationary. At tray full, the job halts until booklets are removed from the lower tray.)
<b>Solenoids</b>		
SOL1	Proof Junction Gate Solenoid	Opens and closes the proof tray junction gate. When the solenoid switches on, it opens the gate and paper is diverted to the proof tray. When this gate is closed, the paper goes straight to the upper tray.
SOL2	Stapling Tray Junction Gate Solenoid	Directs paper to the stapling tray. When this solenoid is on, paper feeds straight through. When this solenoid is off, paper feeds to the stapler tray below.

## Component Layout

No.	Component	Function
SOL3	Positioning Roller Solenoid	Engages the stapler transport motor and the positioning roller of the stapling tray. The positioning roller pushes each sheet down against the bottom fence to align the bottom the stack for stapling. (The jogger fences align the sides.)
SOL4	Stapling Edge Pressure Plate Solenoid	Operates the pressure plate of the stapling unit. The pressure plate presses down the edge of stack in the stapling tray so it is tight for stapling.
SOL5	Booklet Pressure Roller Solenoid	When the paper stack in the stapling tray feeds to the folding unit, this solenoid turns on and operates the roller that pushes on the surface of the stack to flatten it.
<b>Switches</b>		
SW1	Front Door Safety Switch	The safety switch that cuts the dc power when the front door is opened.
SW2	Upper Tray Limit SW	A micro-switch that cuts the power to the upper tray lift motor when the upper tray reaches its upper limit. This switch duplicates the function of the upper tray limit sensor (S12) and stops the upper tray if S12 fails.

## 2.1.4 DRIVE LAYOUT

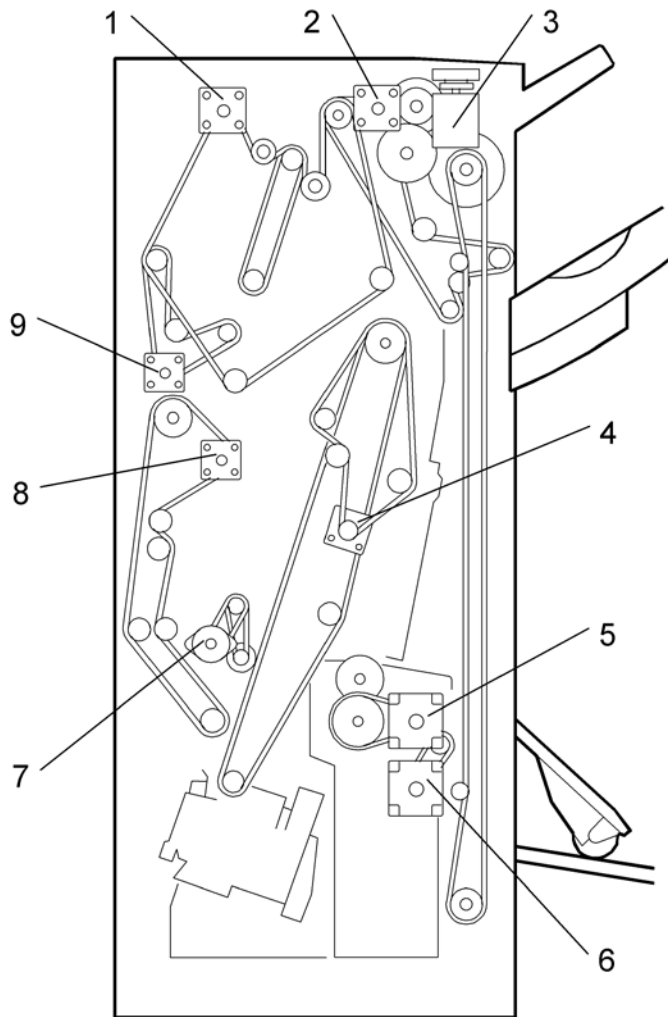

b804d206

- 1. Upper Transport Motor (M2)
- 2. Upper/Proof Exit Motor (M4)
- 3. Upper Tray Lift Motor (M21)
- 4. Feed-Out Belt Motor (M5)
- 5. Fold Roller Motor\*<sup>1</sup> (M12)

- 6. Folder Plate Motor\*<sup>1</sup> (M11)
- 7. Positioning Roller Motor (M14)
- 8. Lower Transport Motor (M3)
- 9. Entrance Motor (M1)

\*<sup>1</sup>: B804 Only

**Booklet Finisher  
& Finishers  
(B803/B805/  
D373/D374/  
D636/D637)**

## 2.2 JUNCTION GATES

The positions of the proof tray and staple tray junction gates determine the direction of paper feed after paper enters the finisher.

### 2.2.1 PROOF MODE

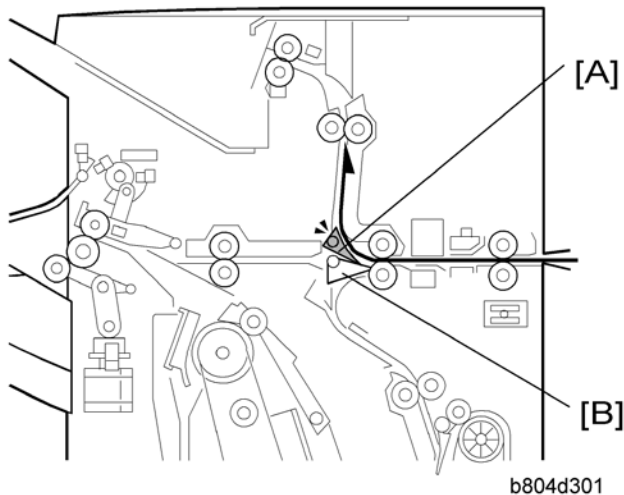

Proof tray junction gate [A] opens. Staple tray junction gate [B] remains closed. The proof tray junction gate directs paper to the proof tray above.

### 2.2.2 SHIFT MODE

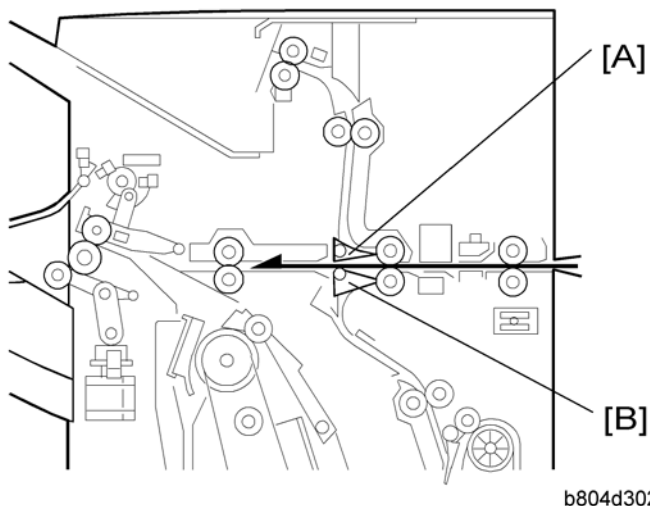

Proof tray junction gate [A] remains closed. Staple tray junction gate [B] remains closed. With both junction gates closed, the paper goes to the upper tray.

### 2.2.3 STAPLE MODE

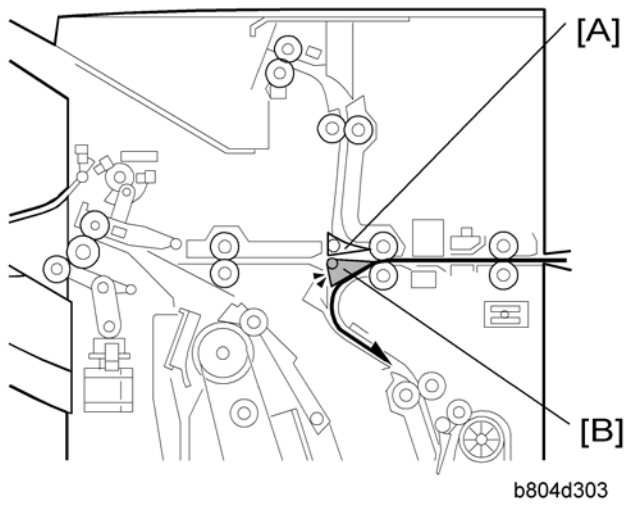

Proof tray junction gate [A] remains closed. Staple tray junction gate [B] opens

The staple tray junction gate directs the paper to the staple tray below for jogging and stapling.

Booklet Finisher  
& Finishers  
(B803/B805/  
D373/D374/  
D636/D637)

## 2.3 PRE-STACKING

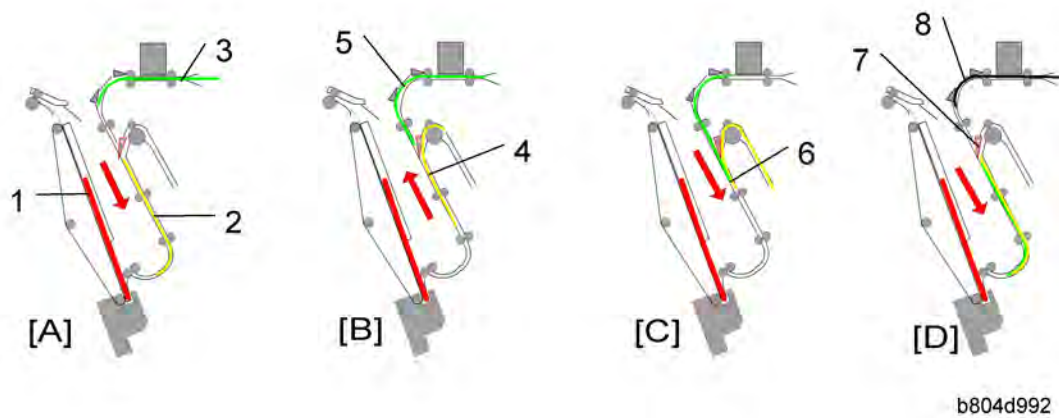

This example describes what happens to Set 2 during the feed and stapling cycle of sets that contain three pages.

- [A]: While the Set 1 is being stapled in the staple tray [1], the 1st sheet of Set 2 [2] feeds to the pre-stack tray, and the 2nd sheet of Set 2 [3] enters the finisher.
- [B]: The pre-stack junction gate opens and the 1st sheet of Set 2 [4] switches back to the top of the pre-stack tray as the 2nd sheet of Set 2 [5] starts to descend.
- [C]: As the 2nd sheet of Set 2 continues to descend, the 1st sheet of Set 2 is fed from the pre-stack tray. At this time the leading edges [6] of both sheets are even.
- [D]: The trailing edges of the 1st and 2nd sheets of Set 2 pass the junction gate [7] as the 3rd sheet of Set 2 [8] enters the finisher.

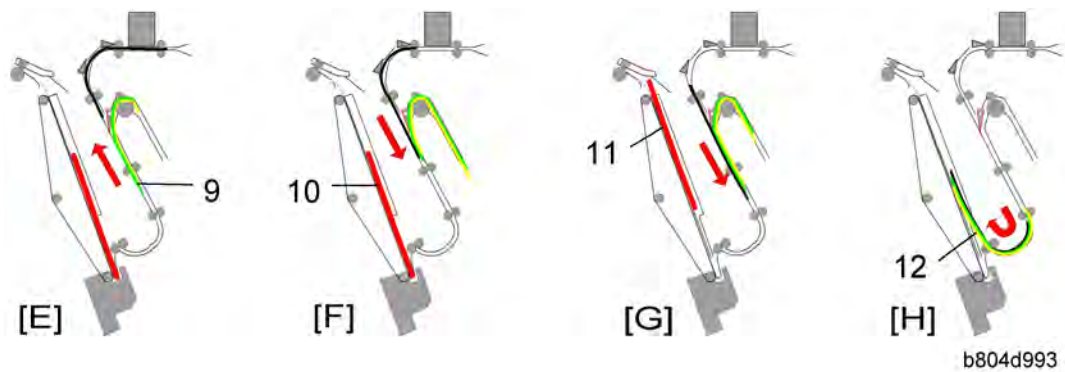

- [E]: The 1st and 2nd sheets of Set 2 [9] switch back together into the top of the pre-stack and wait for the 3rd of Set 2 sheet to arrive.
- [F]: The stapling of Set 1 in the staple tray [10] is completed.
- [G]: Set 1 [11] exits the staple tray.
- [H]: The three sheets of Set 2 [12] feed together into the stapler tray for stapling.

Pre-stacking is only done for A4, B5, and LT paper.

In one-staple mode, one sheet goes to the pre-stacking tray. Then two sheets go to the stapler tray at the same time.

In two-staple mode and booklet mode, three sheets go to the pre-stacking tray. Then four sheets go to the stapler tray at the same time.

Booklet Finisher  
 & Finishers  
 (B803/B805/  
 D373/D374/  
 D636/D637)

## 2.4 TRAY MOVEMENT MECHANISM

### 2.4.1 UPPER TRAY

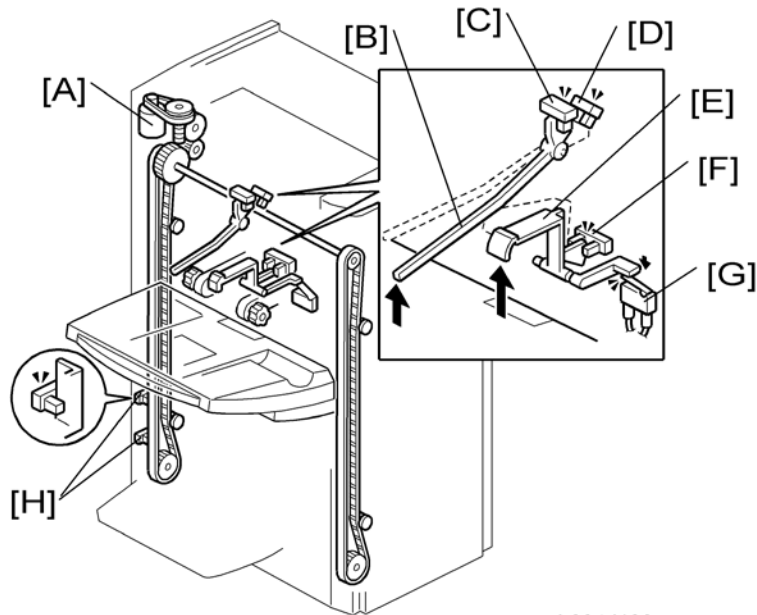

<p>[A]: Upper Tray Lift Motor                  [B]: Upper Feeler                  [C]: Upper Tray Paper Height Sensor 1 (Staple Mode)                  [D]: Upper Tray Paper Height Sensor 2 (Non-Staple Mode)</p>	<p>[E]: Lower Feeler                  [F]: Upper Tray Limit Sensor                  [G]: Upper Tray Limit Switch                  [H]: Upper Tray Full Sensors</p>
--	--

**★ Important**

- The B804 (shown above) has only one upper tray full sensor (the higher sensor at [H]).
- The B805 has two upper tray full sensors (the upper and lower sensor at [H]). On the B805 the upper sensor detects tray full for heavier paper (A3, DLT, B4, LG, 12 x 18”), and the lower sensor detects tray full for lighter paper (A4, LT, etc.).
- The tray full capacity is 2,000 sheets (B804) for A4, LT and 3,000 sheets (B805) for A4, LT.

Five sensors and one switch control the operation of the upper tray lift motor [A].



**Upper Tray Raising and Lowering**

Operation Mode	Sensors, Switch				Action
	[C]	[D]	[F]	[G]	
Standby (Non-Staple Mode)	OFF	OFF			Stops the lift motor is at the standby position when the actuator of the upper feeler deactivates sensor [C] (when it is between sensors [C] and [D]). <b>Note:</b> Sensor [F] and switch [G] are used as backup if sensor [C] fails or if the upper tray is not attached.
Straight Through			ON		<b>Non-staple mode operation:</b> During operation, tray lift is controlled only by sensor [F]. When the actuator leaves sensor [F], the tray lowers until the actuator reactivates sensor [F].
Shift			ON		
Standby (Staple Mode)	ON				<p><b>Standby:</b> The upper tray stops and waits for the paper output when the actuator activates sensor [C]. [D] is not used for staple mode</p> <p><b>Staple Mode Operation:</b></p> <ul style="list-style-type: none"> <li>▪ The upper tray lowers the prescribed distance immediately after the stack exits.</li> <li>▪ The upper tray rises until the actuator activates sensor [C] and stops the tray lift motor (and the tray) to wait for the next set.</li> <li>▪ Sensor [F] and switch [G] are used as backup if sensor [C] fails.</li> </ul>

**Booklet Finisher  
& Finishers  
(B803/B805/  
D373/D374/  
D636/D637)**

**Tray Full**

B804	When the actuator on the tray activates the upper tray full sensor [H] the tray lift motor [A] switches off. Operation resumes after some copies are removed from the tray. Upper Tray Capacity: 2,000 sheets (A4, LT)
B805	The operation of the upper tray full sensor is the same as the B804. Capacity: 1,500 sheets for A3, B4 or other large paper. An additional upper tray full sensor (below sensor [H]) allows more sheets to stack on the upper tray. Capacity: 3,000 sheets (A4, LT)

**2.4.2 LOWER TRAY (B804 ONLY)**

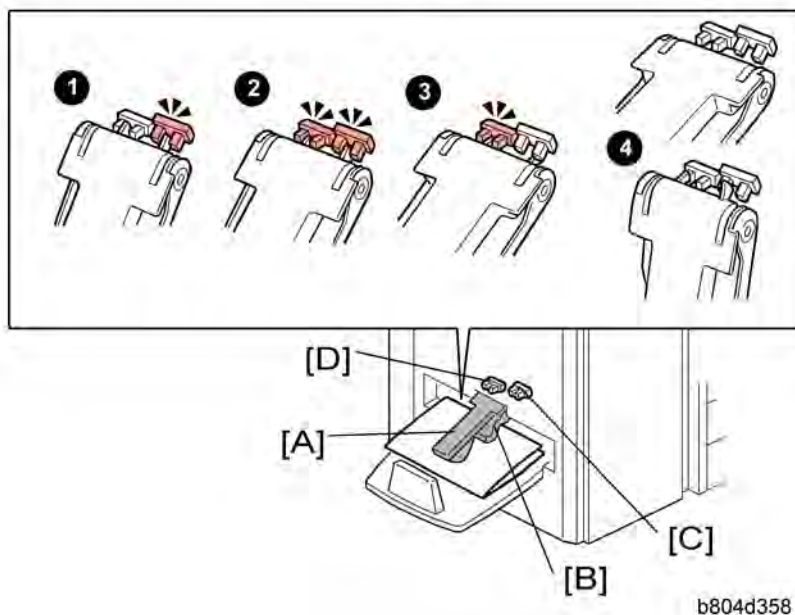

The lower tray sensor actuator arm [A] rests on the top of the stack of stapled booklets as they are output to the lower tray. A flap depressor [B] keeps the open ends of the booklets down. The front lower tray full sensor (S34) [C] and rear lower tray full sensor (S33) [D] detect when the lower tray is full of booklets.

**★ Important**

- The front lower tray full sensor is mounted higher than the rear lower tray full sensor.
- The lower tray is stationary. When it becomes full, the stapling and folding job stops until booklets are removed from the tray.
- If the lower tray is not installed (this is detected if the front and rear sensors remain OFF), the machine will not operate in the booklet staple and fold mode. When booklet mode is selected, the tray full message appears on the operation panel.

The combinations of the two actuators and two sensors as the actuator arm rises determines the number of booklets that the lower tray can hold before the job stops.

The tray full detection depends on the size of the paper and the number of sheets in one stapled and folded booklet.

In the table below, the conditions (① Ready ② Full 1, ③ Full 2 ④ Full 3: See the illustration on the previous page) refer to the states of the sensors described on the previous page.

Condition	Front Sensor	Rear Sensor
Ready	ON	OFF
Full 1	ON	ON
Full 2	OFF	ON
Full 3 (or lower tray not installed)	OFF	OFF

**Booklet Finisher  
& Finishers  
(B803/B805/  
D373/D374/  
D636/D637)**

In the tables below:

- "Sht" denotes "sheets in a stack".
- "Cnt" denotes "Count" (see below for an explanation).

After a booklet is feed out, the fold roller motor stops the exit roller. The machine then monitors the tray full sensors every 100 ms. The machine checks for a certain condition, based on the size of the paper and the number of sheets in the booklet.

An example is shown below. Tell the operators that the number of sheets that the lower tray can hold will vary greatly.

**Lower Tray Full Condition Table**

**A3 (DLT)**

	1 Sht	2 Sht	3 Sht	4 Sht	5 Sht	6 Sht	7 Sth	8 Sht	9 Sht	...
<b>Full 1</b>	3 Cnt	—	—	—	—	—	—	—	—	...
<b>Full 2</b>	—	5 Cnt	15 Cnt	—	—	—	—	—	—	...
<b>Full 3</b>	—	—	—	7 Cnt	13 Cnt	4 Cnt	2 Cnt	2 Cnt	2 Cnt	...

**A4 (LT)**

	1 Sht	2 Sht	3 Sht	4 Sht	5 Sht	6 Sht	7 Sth	8 Sht	9 Sht	...
<b>Full1</b>	16 Cnt	—	—	—	—	—	—	—	—	...
<b>Full 2</b>	—	10 Cnt	10 Cnt	15 Cnt	20 Cnt	15 Cnt	10 Cnt	8 Cnt	8 Cnt	...
<b>Full 3</b>	—	—	—							...

**Examples:**

After the copier makes a booklet with 1 sheet of A3/DLT paper, the machine checks every 100 ms for the 'Full 1' condition. If the Full 1 condition occurs 3 times (shaded block in the table above), the machine detects that the tray is full.

After the copier makes a booklet with 5 sheets of A4/LT paper, the machine checks every 100 ms for the 'Full 2' condition. If the Full 2 condition occurs 20 times (shaded block in the table above), the machine detects that the tray is full.

## 2.5 CORNER STAPLING

### 2.5.1 STACKING AND JOGGING

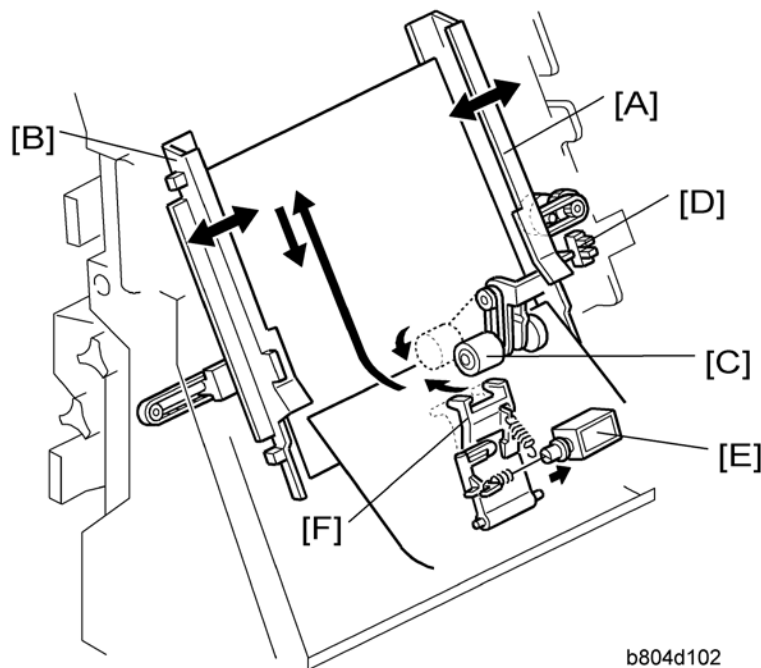

[A]: Jogger Fence Motor (M15)

[B]: Jogger Fences

[C]: Positioning Roller

[D]: Jogger Fence HP Sensor (S15)

[E]: Stapling Edge Pressure Plate Solenoid (SOL4)

[F]: Pressure Plate

At the beginning of the job, the jogger fence motor (M15) [A] switches on and moves the jogger fences [B] to the standby position (7.5 mm from the sides of the selected paper size).

When each sheet passes the pre-stack tray exit sensor (S2) and enters the stapling tray:

- The jogger fence motor switches on and moves the jogger fences to within 5.5 mm of the sides of the selected paper size.
- The positioning roller solenoid (SOL3) switches on for the time prescribed for the paper size. This pushes the positioning roller [C] onto the sheet and pushes it down onto bottom fence. This aligns the edge of the stack.

Next, the jogger fence motor:

- Switches on again and moves the jogger fences to within 2.6 mm of the sides of the stack to align the sides of the stack.
- Reverses and moves the fences to the standby position (7.5 mm away for the sides) and waits for the next sheet.

## Corner Stapling

- The jogger fence HP sensor [D] switches off the jogger motor at the end of the job.

After the last sheet feeds:

- The stapling edge pressure plate solenoid [E] (SOL4) switches on and pushes the pressure plate [F] onto the stack to press down the edge for stapling.
- The corner stapler staples the stack.

### 2.5.2 STAPLER MOVEMENT

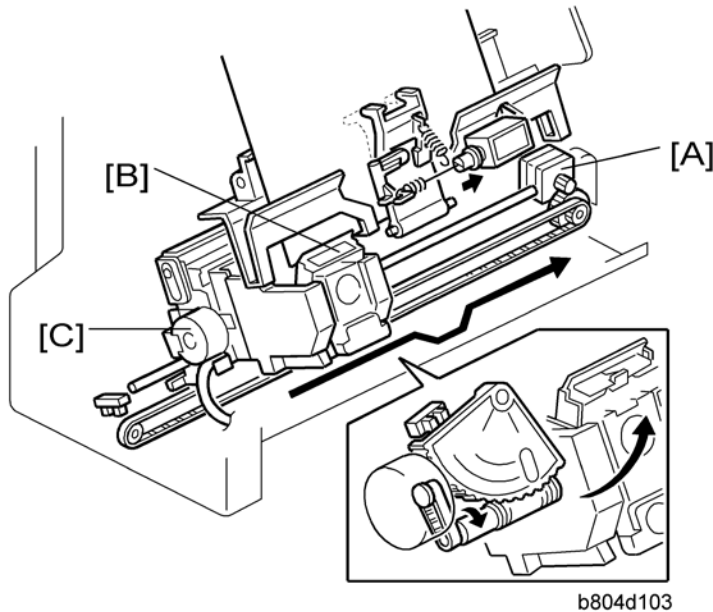

[A]: Stapler Movement Motor  
[B]: Stapler  
[C]: Stapler Rotation Motor

The stapler performs horizontal and rotational movement in each of the four staple modes:

- Front 1 staple
- Rear 1 staple
- Rear diagonal staple
- Rear/Front 2 staples

The stapler movement motor [A] drives a timing belt that moves stapler [B] left and right on its stainless steel rail.

The stapler rotation motor [C] rotates the stapler into position for diagonal stapling at the rear.

- The stapler movement motor switches on and moves the stapler the standby stapling position. (This is the stapling position for the paper size selected for the job.)
- The stapler movement motor switches off and the stapler waits for the signal to fire (or swivel and for diagonal stapling).

If the stack is to be stapled at two positions:

- The stapler movement motor moves the stapler to the front position and staples the front.
- The stapler movement motor moves the stapler to the rear and the stapler staples the rear.

If the stack is stapled at the rear with a diagonal staple, the staple moves to the rear. When it is time for stapling, the rotation motor rotates the stapler to the correct angle and holds the stapler in that position while the stapler fires.

The stapling positions can be fine adjusted with **SP6-133-001**.

### 2.5.3 CORNER STAPLING

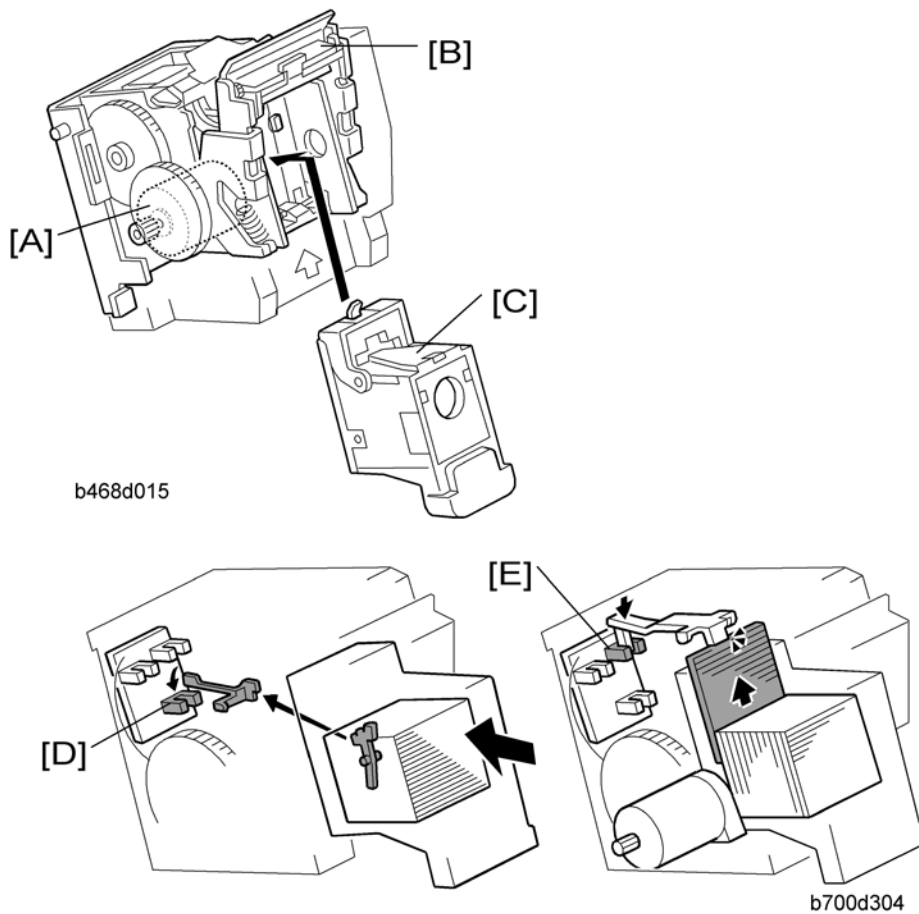

Staple firing is driven by the stapler motor [A] inside the stapler unit. The stapler hammer [B] fires the stapler [C].

The cartridge set sensor [D] detects the cartridge at the correct position.

The staple end sensor [E] detects the staple end condition.

Booklet Finisher  
& Finishers  
(B803/B805/  
D373/D374/  
D636/D637)

## 2.6 BOOKLET STAPLING (B804 ONLY)

### 2.6.1 BOOKLET PRESSURE MECHANISM

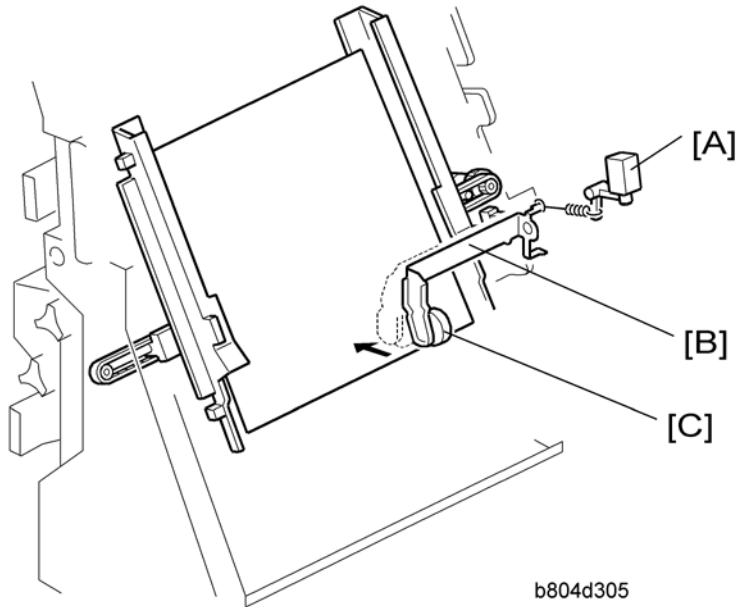

[A]: Booklet Pressure Roller Solenoid (SOL5)

[B]: Booklet Pressure Roller Arm

[C]: Booklet Pressure Roller

As soon as the edges are aligned by the positioning roller and the jogger fences, the stack feed out belt moves.

In booklet mode, immediately after the edges are aligned by the positioning roller and jogger fences, the booklet pressure solenoid switches on and the booklet pressure roller presses down on the stack until booklet stapling is finished. This prevents the stack from shifting during stapling.



## 2.6.2 BOOKLET STAPLING AND FOLDING

### Overview

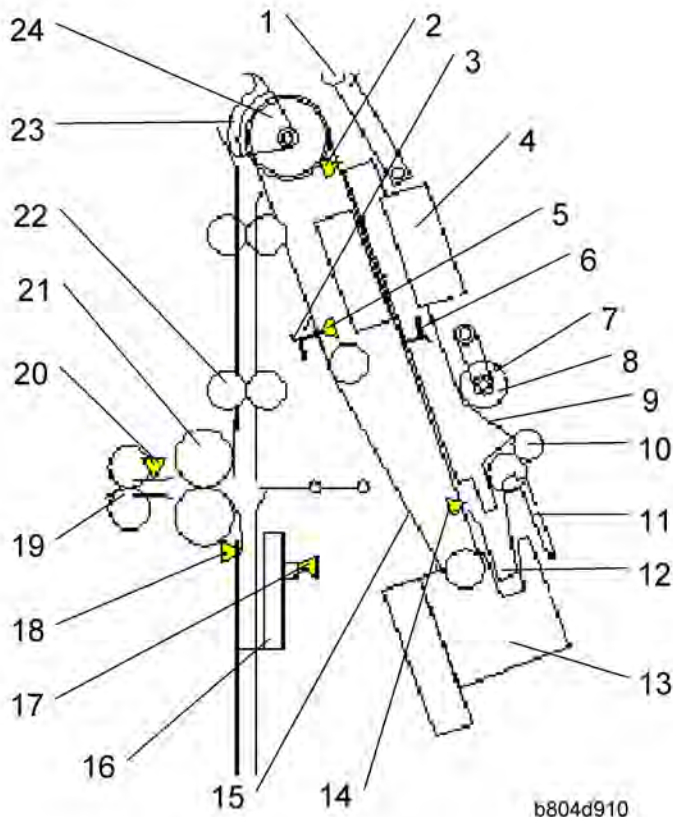

Booklet Finisher  
 & Finishers  
 (B803/B805/  
 D373/D374/  
 D636/D637)

1. Leading Edge Pressure Roller	13. Corner Stapler (M20)
2. Stack Present Sensor (S32)	14. Stapling Tray Paper Sensor (S14)
3. Feed Out Belt Pawl 1	15. Feed Out Belt
4. Booklet Staplers x2 (M22, M23)	16. Fold Unit Bottom Fence
5. Stack Feed Out Belt HP Sensor (S16)	17. Fold Bottom Fence HP Sensor (S28)
6. Feed Out Belt Pawl 2	18. Fold Unit Entrance Sensor (S26)
7. Positioning Roller	19. Fold Unit Exit Rollers x2
8. Booklet Pressure Roller (Rear)	20. Fold Unit Exit Sensor (S31)
9. Jogger Fences x2	21. Fold Rollers x2
10. Pre-Stack Exit Roller	22. Clamp Rollers x2
11. Pressure Plate	23. Stack Junction Gate
12. Stapling Tray Bottom Fence	24. Stack Transport Roller

## Booklet Stapling (B804 Only)

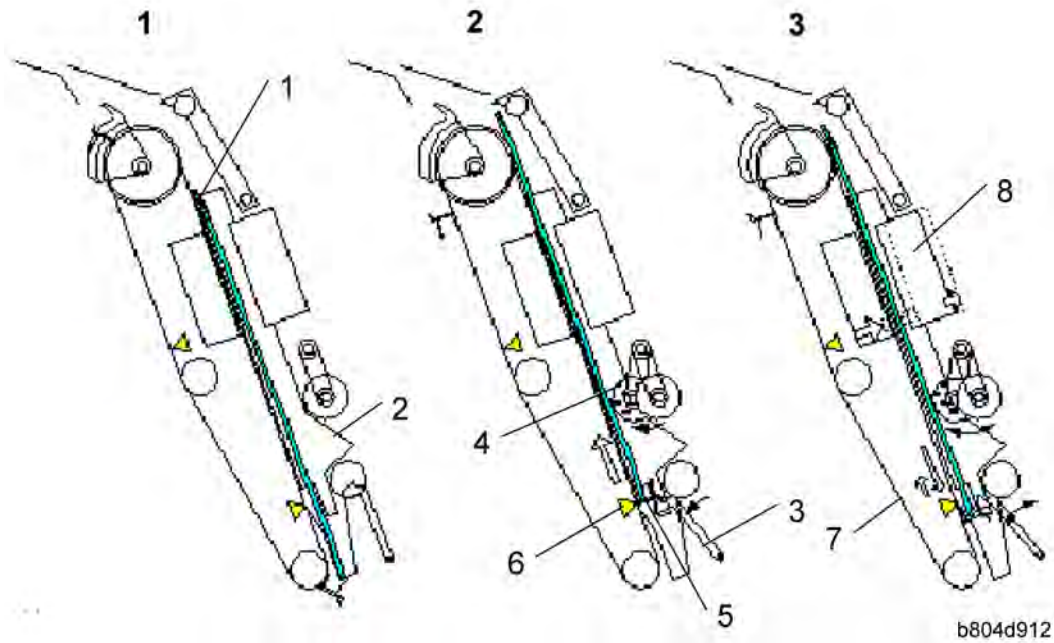

### 1:

The last sheet of the stack [1] enters the stapling tray. The jogger fences [2] jog the last sheet into position (based on the width of the selected paper size) and then retract and stop 1 mm away from the sides of the stack.

### 2:

The pressure plate [3] and booklet pressure roller [4] press down on the sheet. The stack feed out belt switches on and the pawl [5] on the feed out belt catches the bottom of the stack and raises it. The stapling tray sensor [6] detects the trailing edge of the paper stack.

### 3:

The feed out belt [7] raises the stack to the prescribed stapling position and stops. The jogger fences move to the sides of the stack and the booklet staplers [8] staple the stack.

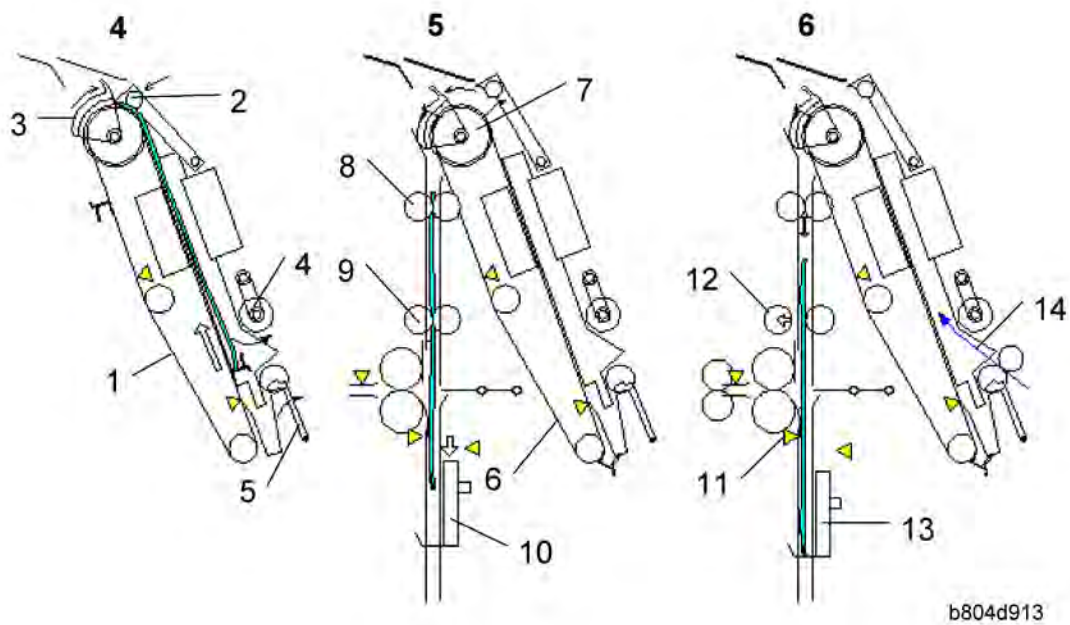
**4:**

The jogger fences remain 1 mm away from the sides of the stack. The feed out belt [1] raises the stack until the top of the stack is 10 mm past the leading edge pressure roller [2] and stops. The leading edge pressure roller descends and applies pressure to the top of the stack. The stack junction gate [3] (normally open) closes. The pressure roller [4] and pressure plate [5] retract.

**5:**

The feed out belt [6], transport rollers [7], [8], and clamp rollers [9] rotate and feed the stack past the closed stack junction, over the top and down toward the bottom fence [10]. At the same time, the fold unit bottom fence descends from its home position and stops 10 mm below the fold position.

**6:**

The rollers feed the leading edge of the stack to within 3 mm of the stack stopper of the bottom fence [13]. The fold unit entrance sensor [11] detects the stack and opens the clamp rollers [12]. The stack drops 3 mm onto the fold unit bottom fence [13]. At this time, the first sheet [14] of the next stack feeds to the stapling tray.

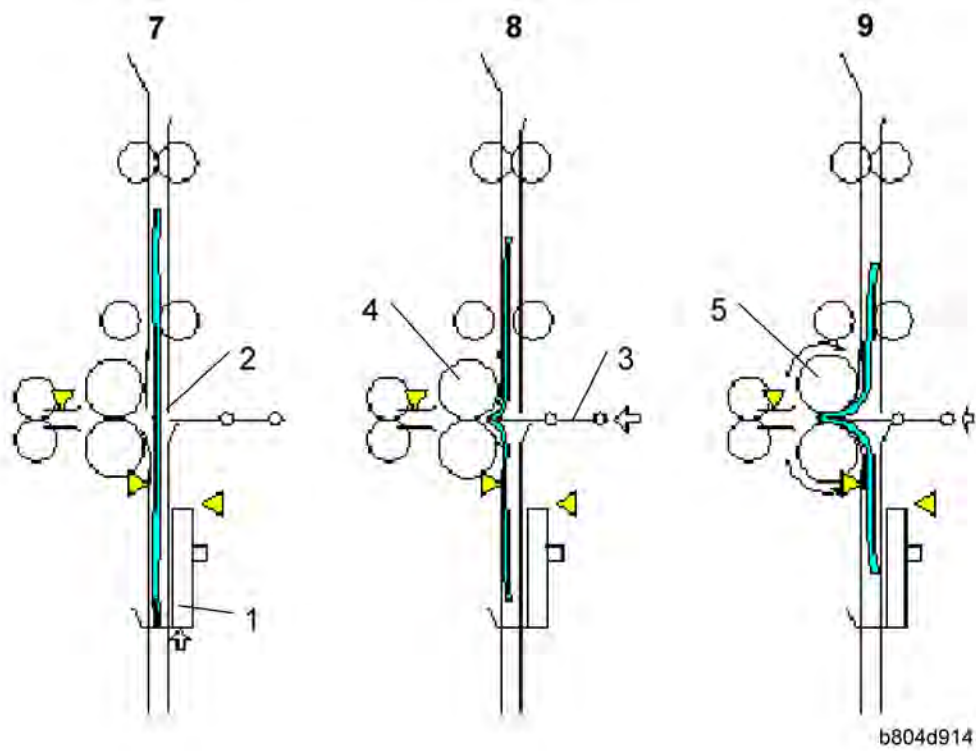

**7:**

The bottom fence [1] raises the stack to the prescribed fold position [2].

**8:**

The fold plate [3] moves to the left and advances 1/3 its maximum horizontal stroke and exerts 20 kg (44 lb.) of pressure at the fold rollers [4].

**9:**

With the fold plate pushing the stack into nip of the fold rollers [5], the fold rollers begin to rotate and fold the stack as it feeds out.

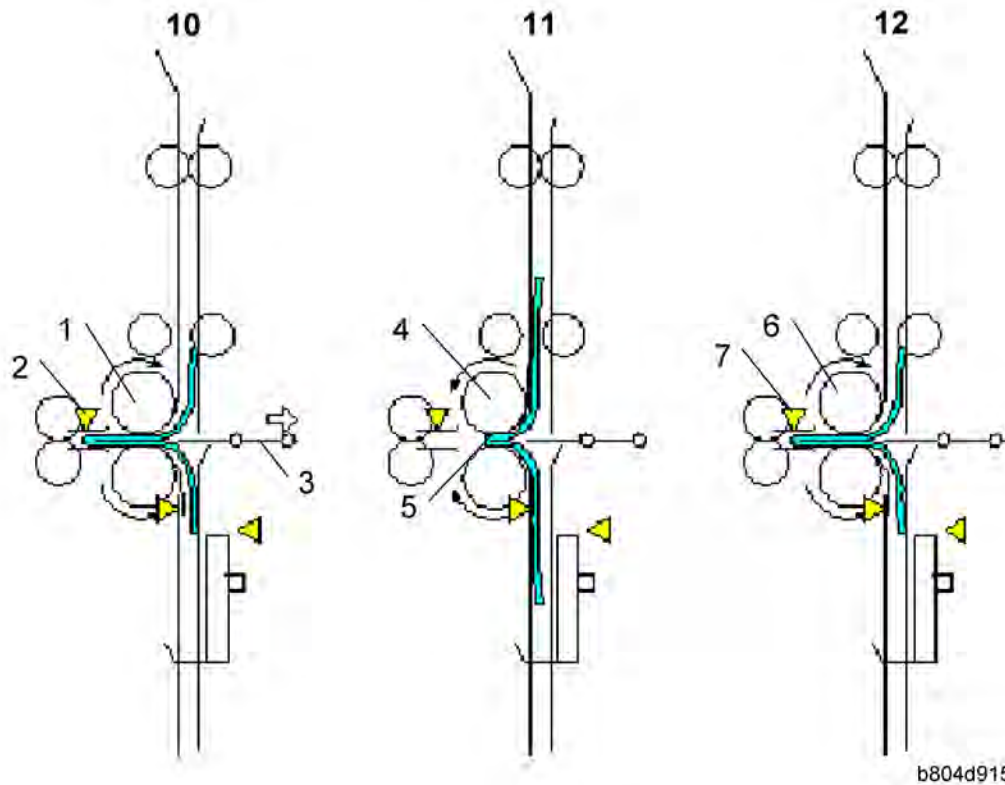
**10:**

When the fold rollers [1] feed the stack 10 mm past the nip, the fold plate retracts until it no longer touches the stack. The fold unit exit sensor [2] detects the folded edge of the stack and stops the fold rollers.

**11:**

The rotation of the fold rollers [4] reverses and feeds the folded edge back until only 3 mm of the fold [5] remains at the nip.

**12:**

The fold rollers [6] rotate forward once again feed out. The fold unit exit sensor [7] once again detects the edge of the fold.

↓ Note

- You can do **SP6-136-001** to increase the sharpness of the fold. The number of forward and reverse feeds can be set in the range of 2 to 30. The machine repeats Steps 11 and 12. For more, please refer to Section "Service Tables".

Booklet Finisher  
& Finishers  
(B803/B805/  
D373/D374/  
D636/D637)

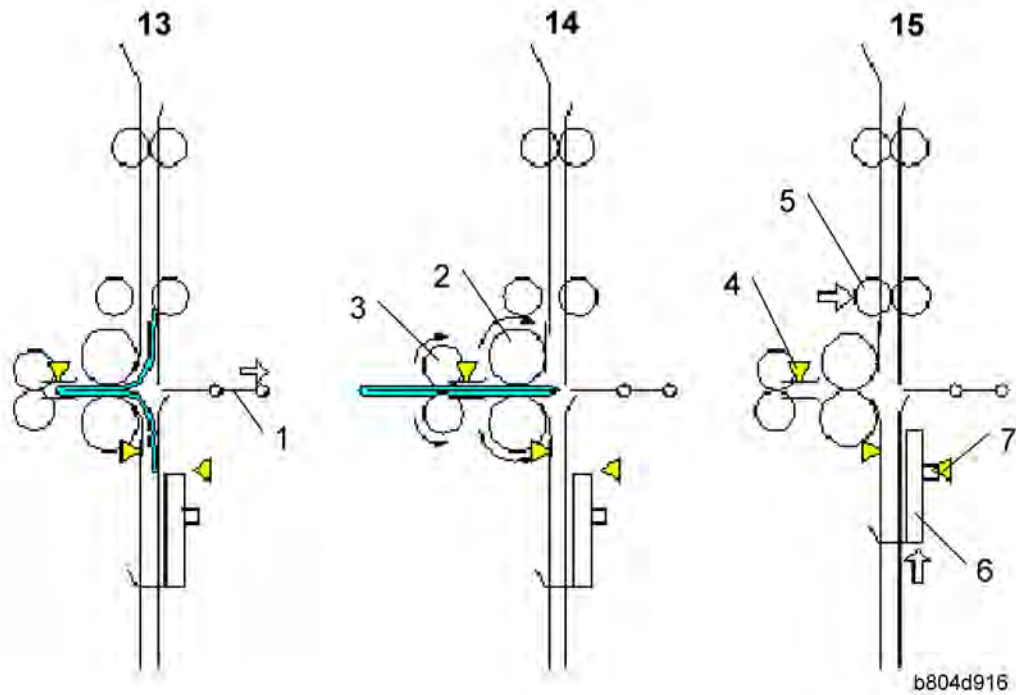

**13:**

With the feed of the stack halted, the fold plate [1] retracts. The fold plate HP sensor (not shown) detects the fold plate and stops it at its home position.

**14:**

The fold rollers [2] and fold unit exit rollers [3] begin to rotate together and feed out the folded booklet to the lower tray.

**15:**

Once the trailing edge of the stack passes the fold unit exit sensor [4], the clamp rollers [5] close to be ready to feed the next stack. The fold unit bottom fence [6] descends. The bottom fence HP sensor [7] stops the bottom fence when it detects the actuator on the bottom fence.

### 2.6.3 BOOKLET STAPLING AND FOLDING MECHANISMS

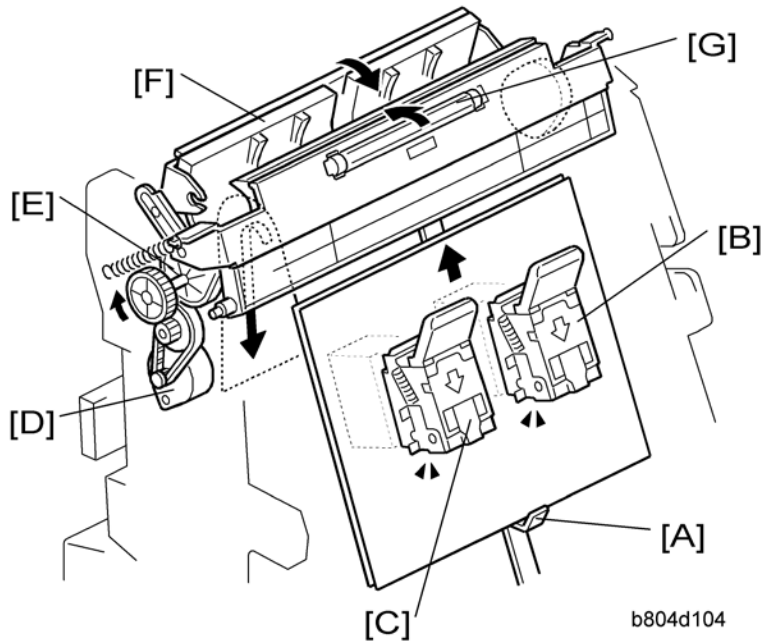

#### Booklet Stapler

[A]: Feed Out Belt Pawl. Raises the stack to stapling position.

[B]: Booklet Stapler EH185R – Rear

[C]: Booklet Stapler EH185R – Front

#### Stack Junction Gate

[D]: Stack Junction Gate Motor. Drives a timing belt and stack junction gate cam.

[E]: Stack Junction Gate Cam. Opens and closes the stack junction gate.

[F]: Stack Junction Gate. The stack junction gate motor and stack junction gate cam close the stack junction gate. The feed out belt pawl raises the stapled stack and sends it over the top and down to the fold unit.

[G]: Leading Edge Pressure Roller. Presses down on the leading edge of the stack after booklet stapling.

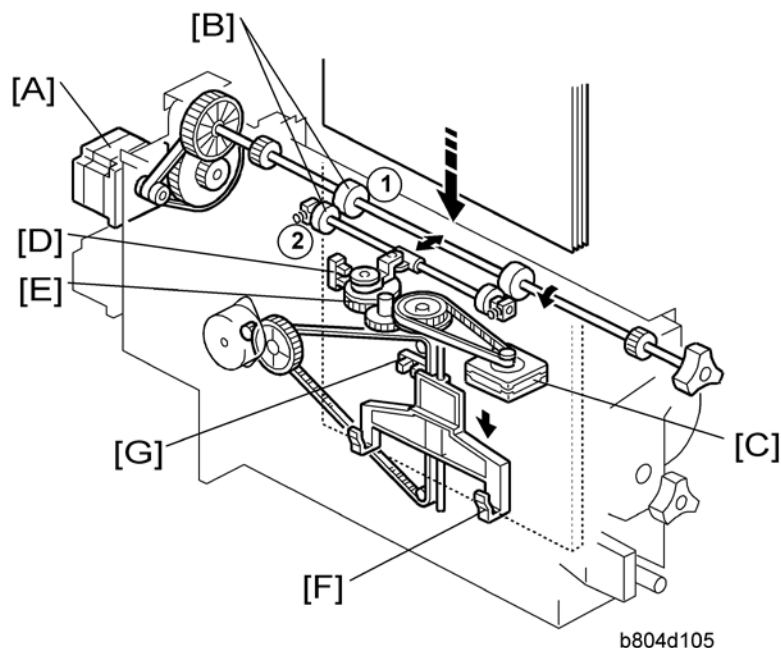

### Clamp Roller

[A]: Fold Roller Motor. Drives the stationary clamp drive roller ① as well as the fold rollers (see next page).

[B]: Clamp Rollers.

① Clamp Roller – Drive. Rotated by the fold roller motor, this stationary roller feeds the stack down with the retracting roller closed.

② Clamp Roller – Retracting. Opened and closed by the retraction motor [C].

[C]: Clamp Roller Retraction Motor. Operates the clamp roller cam that retracts the retracting clamp roller. The clamp rollers feed the stack to within 3 mm of the bottom fence when closed and then open to drop the stack onto the bottom fence.

[D]: Clamp Roller HP Sensor. Controls the rotation of the clamp roller retraction motor and cam that open and close the retracting clamp roller.

[E]: Clamp Roller Cam. Forces open the spring loaded retracting clamp roller.

### Bottom Fence

[F]: Bottom Fence. Raises the booklet stapled stack to the fold position.

[G]: Bottom Fence HP Sensor. Detects the actuator on the bottom fence and stops it at the home position after folding.

[H]: Bottom Fence Lift Motor. Raises the bottom fence and stapled stack to the fold position prescribed for the paper size.



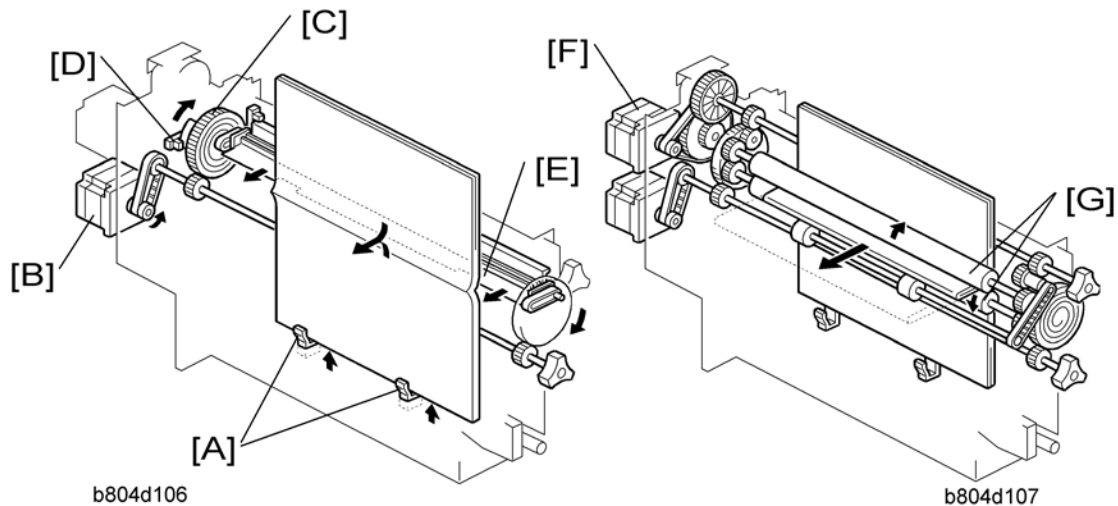

### Fold Plate

[A]: Bottom Fence Stack Stoppers. Catches the stack after it is released by the clamp rollers.

[B]: Fold Plate Motor. Drives the timing belt and gears that move the fold plate.

[C]: Fold Plate Cam. Controls the movement of the fold plate to the left (into the nip of the fold rollers) and right (toward the fold plate home position).

[D]: Fold Plate HP Sensor. Controls operation of the fold plate motor.

[E]: Fold Plate. Moves left and pushes the stack into the nip of the fold rollers and then moves right to retract.

### Fold Rollers

[F]: Fold Roller Motor. Drives forward to feed out the stack at the fold and then reverses to feed the fold in to sharpen the crease, and then drives forward again to feed out the folded stack. This reverse/forward cycle is done once.

#### ↓ Note

- This cycle can be repeated by changing the setting of SP6114.

[G]: Fold Rollers. Driven by the fold roller motor, this roller pair feeds out the stack at its fold, reverses to feed in the stack to, and then feeds forward again (assisted by the fold unit exit rollers – not shown) to feed out the stack to the lower tray.

Booklet Finisher  
& Finishers  
(B803/B805/  
D373/D374/  
D636/D637)

## 2.7 UPPER TRAY OUTPUT

### 2.7.1 FEED OUT

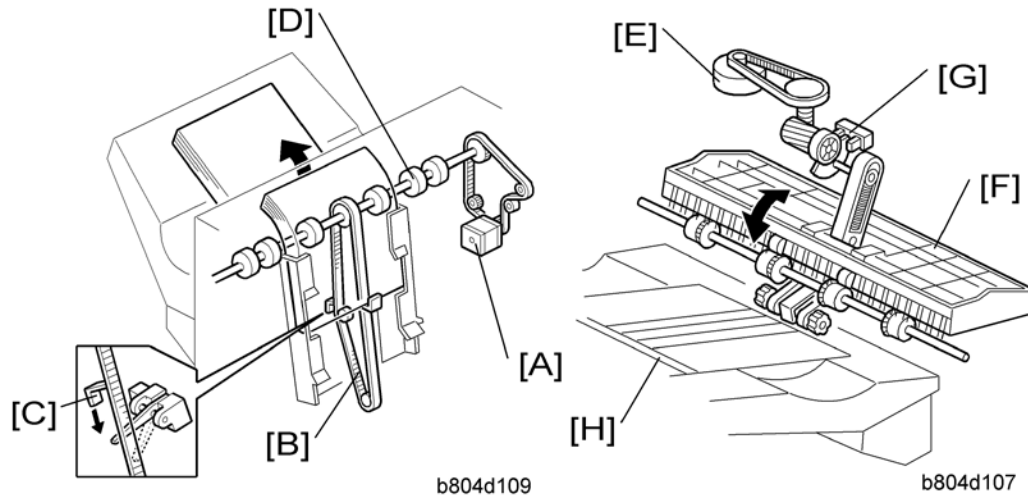

- [A]: Feed Out Belt Motor
- [B]: Stack Feed-Out Belt
- [C]: Pawl
- [D]: Exit Rollers
- [E]: Exit Guide Plate Motor
- [F]: Exit Guide Plate
- [G]: Exit Guide Plate HP Sensor
- [H]: Upper Tray

After the stack is stapled, the feed out belt motor [A] switches on and drives the feed out belt [B]. The pawl [C] attached to the feed out belt catches on the stack and lifts the stack toward the feed out slot.

The exit guide plate [F] remains open as the stack emerges at a prescribed distance away from the exit roller.

Next, the exit guide plate closes and the exit roller feeds the stack out.

The opening and closing of the exit guide plate is controlled by the rising and falling of a link driven by a rotating cam attached to the shaft of the exit guide plate motor [E].

The feed out belt motor stops 300 ms to prevent the stapled stack from rising too high. Next, the feed out belt motor switches on again, then the pawl actuates its home position sensor and switches off the motor.

There are two output pawls on the feed out belt to improve the productivity of the feed out operation.

## 2.7.2 FEED OUT STACKING

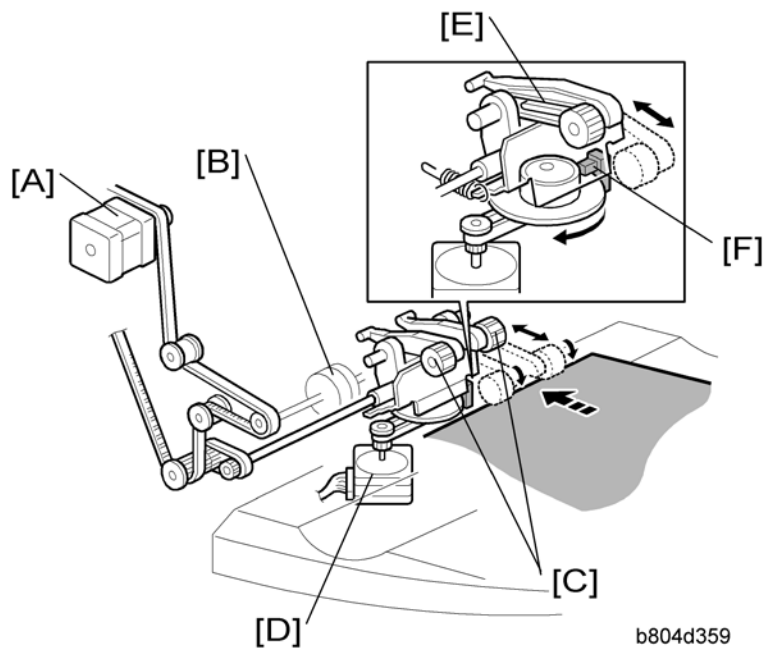

Upper/proof exit motor [A] drives feed roller [B] and stacking sponge roller [C]. Stacking sponge roller motor [D] moves the sponge roller forward and back with link [E]. The position of the stacking sponge roller [C] is controlled by the stacking sponge roller motor which is switched on and off by the stacking roller HP sensor [F].

## 2.8 PUNCH UNIT B702 (FOR B804/B805)

### 2.8.1 OVERVIEW OF OPERATION

#### *Skew Correction before Punching*

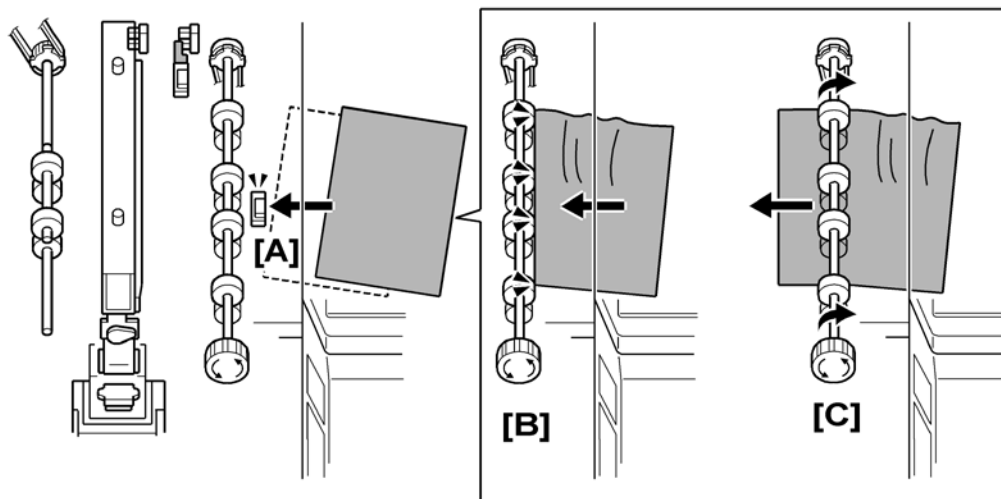

This punch unit corrects for paper skew and then positions the punch unit to punch holes at the correct position. Each sheet is punched one at a time.

Paper feeds out of the copier. The finisher entrance sensor [A] detects the leading edge of the sheet.

The finisher entrance roller [B] stops rotating briefly while the copier exit rollers continue to rotate. This buckles the paper against the finisher entrance roller to correct skew. The finisher entrance roller [C] starts to rotate again and feeds the sheet into the finisher.

These SP codes adjust the skew operation in the punch unit:

- **SP6130.** This SP corrects the punch hole alignment. To do this, it corrects the skew of each sheet by adjusting the amount of time the finisher entrance roller remains off while the exit roller of the machine remains on. For more, see Section "Service Tables".
- **SP6131.** This SP determines whether the finisher entrance roller stops to correct skew when paper enters the finisher. You can use this SP to disable the skew correction. For more, see Section "Service Tables".

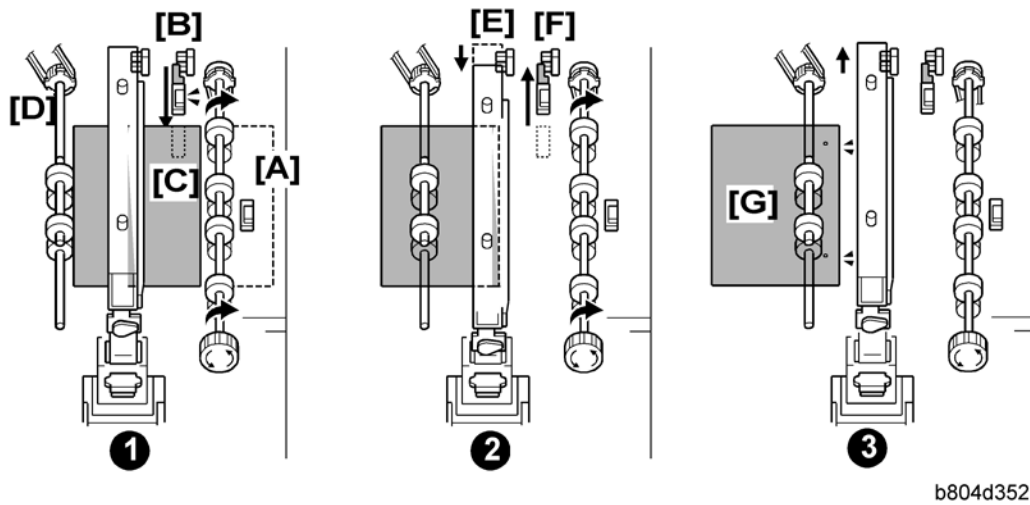
**Punch Unit Position Correction**

b804d352

These operations (skew correction before punching, and punch unit position correction) increase the accuracy of the punch alignment.

**❶:**

The trailing edge of the sheet passes the finisher entrance sensor [A].

The paper position slide unit [B] moves the paper position sensor [C] forward to the edge of the paper.

The paper position sensor detects the position of the paper edge and sends this information to the punch unit board. The machine uses the detected position of the paper edge to calculate the correct position for punching.

The upper transport motor switches on and rotates the feed rollers [D] the prescribed distance to position the paper under the punch unit.

**❷:**

Using the result of the position calculation, the punch unit control board moves the punch unit [E] to the adjusted punch position.

The paper position slide unit and its paper sensor, move back to the paper position slide home position sensor [F], and the punch unit fires the punches to make the holes.

**❸:**

The feed rollers [G] feed the punched paper out of the punch unit and into the paper path.

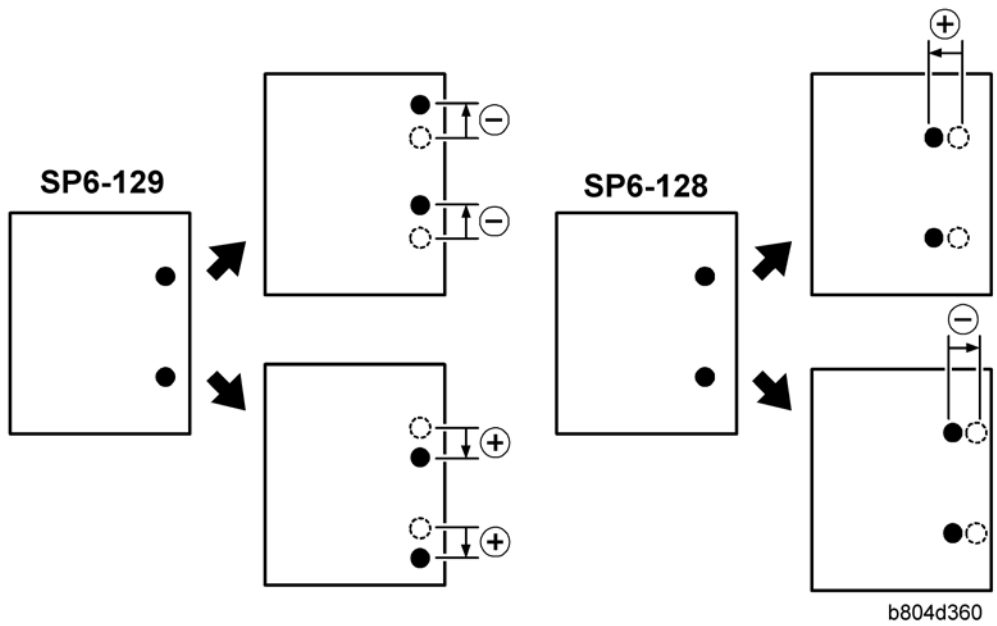

These SP codes adjust the punch hole alignment:

- **SP6-128** Adjusts the punch positions in the direction of paper feed.
- **SP6-129** Adjusts the punch position perpendicular to the direction of feed.

For more, see Section "Service Tables".

## 2.8.2 PUNCH MECHANISMS

### *Paper Position Detection*

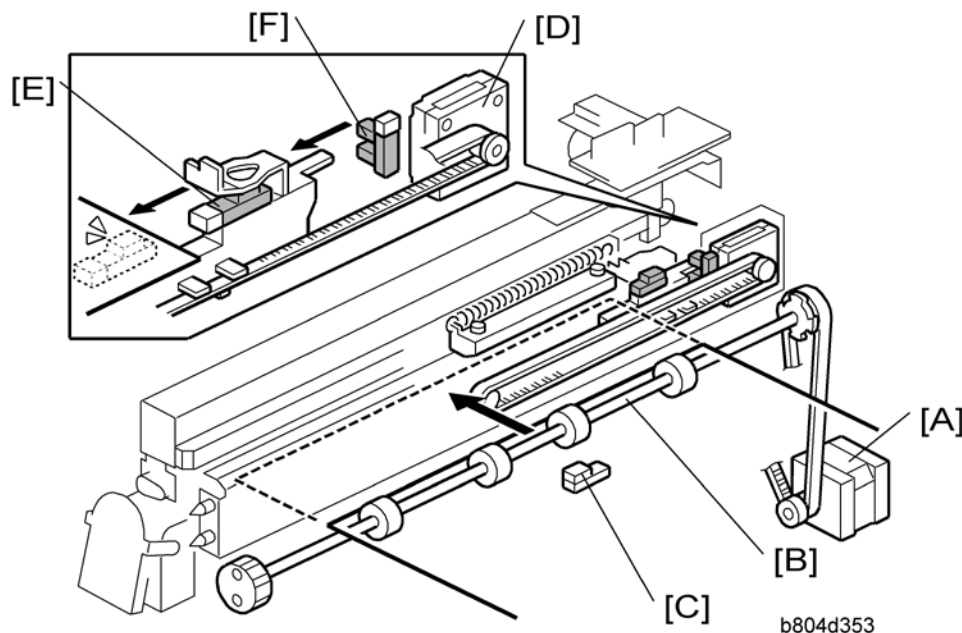

- [A]: Finisher Entrance Motor (M1)
- [B]: Finisher Entrance Roller
- [C]: Finisher Entrance Sensor (S1)
- [D]: Paper Position Sensor Slide Motor (M7)
- [E]: Paper Position Sensor (S27)
- [F]: Paper Position Sensor Slide HP Sensor (S22)

The finisher entrance motor (M1) [A] drives the finisher entrance rollers [B] that feed paper from the copier into the finisher. The finisher entrance sensor (S1) [C] detects paper when it enters the finisher, and detects paper jams.

The paper position slide sensor motor (M7) [D] extends and retracts the paper position slide that holds the paper position sensor (S27) [E]. The paper position sensor detects the position of the paper edge. The detected position of the paper is used to calculate and position the punch unit for punching.

The paper position slide HP sensor (S22) [F] detects the paper position slide when it retracts and stops the paper position slide motor so the slide stops at its home position.

### ***Punch Unit Movement***

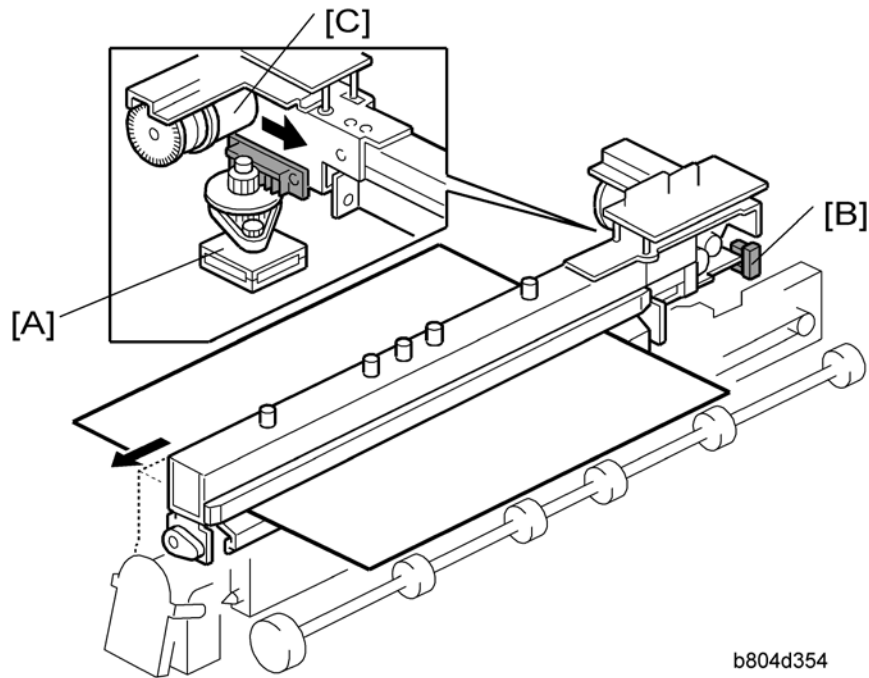

b804d354

- [A]: Punch Movement Motor (M9)
- [B]: Punch Movement HP Sensor (S21)
- [C]: Punch Drive Motor (M24)

The punch movement motor (M9) [A] extends and retracts the punch unit to position it at the correct position for punching.

The punch movement HP sensor (S21) [B] detects the position when it retracts, switches off the punch position movement motor, and stops the punch unit at its home position.

The punch drive motor (M24) [C] fires the punches that punch holes in the paper below.



### Punch Selection and Firing

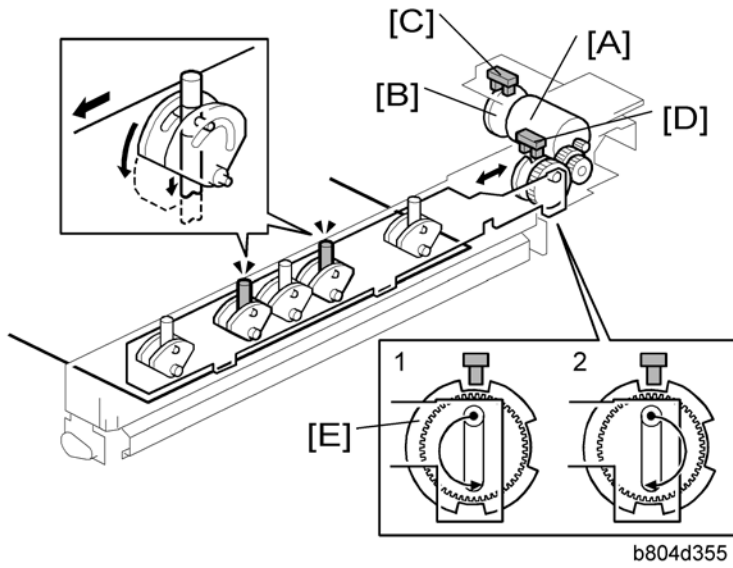

- [A]: Punch Drive Motor (M24)
- [B]: Punch Encoder Wheel
- [C]: Punch Encoder Sensor (S24)
- [D]: Punch HP Sensor (S23)

**Booklet Finisher  
& Finishers  
(B803/B805/  
D373/D374/  
D636/D637)**

The punch drive motor (M24) [A] turns the small, notched encoder wheel [B] through the gap in the punch encoder sensor [C] (S24). The sensor output is used to control the punch timing.

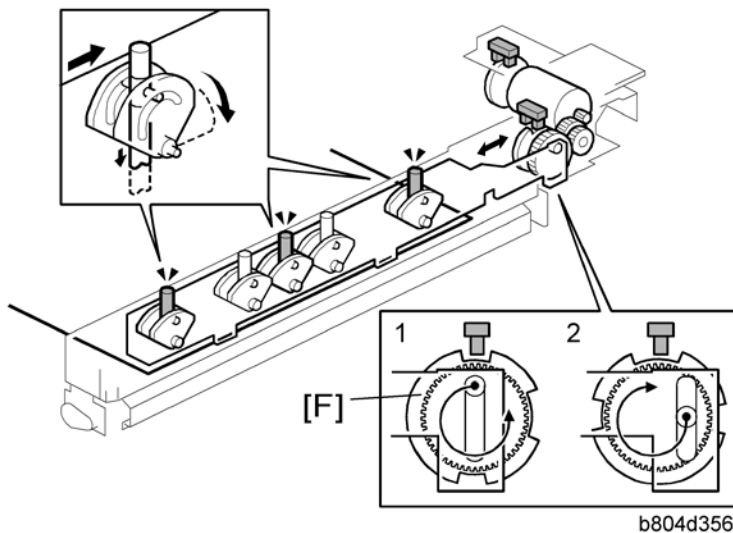

The timing for 2-hole punching [E] is different from 3-hole punching [F].

When the punch unit is at the punching position, the punch motor turns until the encoder detects the starting position for 2-hole or 3-hole punching.

## Punch Unit B702 (For B804/B805)

- This is the '1' position in the diagrams (the top diagram is for 2-hole punching, and the bottom diagram is for 3-hole punching).

Then, the punch drive motor turns counter-clockwise to the '2' position. This movement punches the holes in the paper.

Then, the punch drive motor turns clockwise to the '1' position, to be ready for the next sheet of paper.

### 2.8.3 PUNCH HOPPER MECHANISM

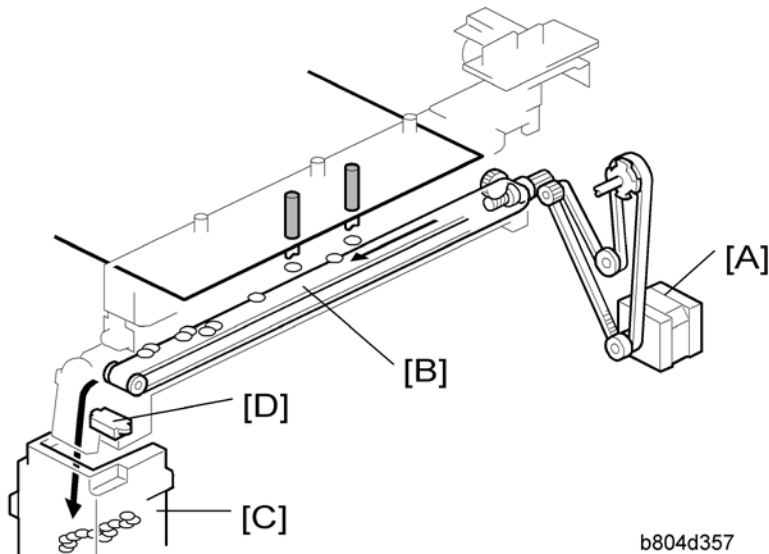

- [A]: Finisher Entrance Motor (M1)
- [B]: Punch Waste Belt
- [C]: Punch Waste Hopper
- [D]: Punch Hopper Full Sensor (S4)

The finisher entrance motor (M1) [A] drives the timing belt and gears that rotate the punch waste belt [B].

The punchouts fall from the punch unit onto the belt. The belt moves the punchouts to the front and dumps them in the punch waste hopper [C].

The punch hopper full sensor [D]:

- Signals that the hopper is full when it detects the top of the stack of punchouts that have collected in the hopper.
- It also detects when the punch hopper is set properly.

## 2.9 FINISHER JAM DETECTION

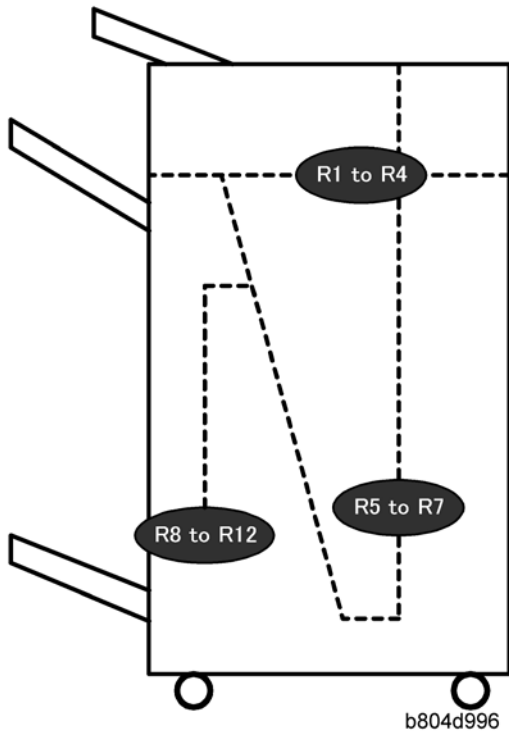

Booklet Finisher  
& Finishers  
(B803/B805/  
D373/D374/  
D636/D637)

Display	Mode	Jam	What It Means
R1 to R3	Proof Shift Staple	Finisher entrance sensor late	After main machine exit sensor goes OFF, finisher entrance sensor does not go ON even after enough time to feed 450 mm.
		Finisher entrance sensor lag	After finisher entrance sensor goes ON, it does not go OFF after enough time to feed a sheet 1.5 times its length has elapsed.
R3	Proof	Proof exit sensor late	After finisher entrance sensor goes ON, proof exit sensor does not go ON even after enough time to feed 450 mm.
		Proof exit sensor lag	After finisher entrance sensor goes OFF, proof exit sensor does not go OFF even after enough time to feed 450 mm.

## Finisher Jam Detection

Display	Mode	Jam	What It Means
R4	Shift	Upper tray exit sensor late	After finisher entrance sensor goes ON, upper tray exit sensor does not go ON even after enough time to feed 485 mm.
		Upper tray exit sensor lag	After finisher entrance sensor goes OFF, upper tray exit sensor does not go OFF even after enough time to feed 650 mm.
R5 to R7	Staple	Pre-stack tray exit sensor lag	After finisher entrance sensor goes ON, pre-stack tray exit sensor does not go ON even after enough time to feed 650 mm.
		Pre-stack tray exit sensor late	After finisher entrance sensor goes ON, pre-stack tray exit sensor does not go OFF even after enough time to feed 1650 mm.
R8 to R12	Booklet Staple (B700 Only)	Fold unit entrance sensor late (S26)	The fold unit entrance sensor goes not go ON after enough time has elapsed to feed 1.5 times the length of the stack after the leading edge of the stack reaches the stack present sensor (S32).
		Fold unit exit sensor late (S31)	The fold unit exit sensor does not go ON after enough time has elapsed for the stack to feed 1.5 times its length from the fold position.
		Fold unit exit sensor lag (S31)	After the fold unit exit sensor goes ON, it does not go OFF after enough time has elapsed to feed 442.9 mm.