



RICOH UNIVERSITY

Learning ♦ Knowledge ♦ Performance



G960

SERVICE MANUAL

003238MIU

LANIER RICOH SAVIN



G960
SERVICE MANUAL

LANIER
RICOH
SAVIN®



RICOH UNIVERSITY
Learning ♦ Knowledge ♦ Performance

G960

SERVICE MANUAL

003238MIU

LANIER RICOH SAVIN

It is the reader's responsibility when discussing the information contained within this document to maintain a level of confidentiality that is in the best interest of Ricoh Americas Corporation and its member companies.

NO PART OF THIS DOCUMENT MAY BE REPRODUCED IN ANY FASHION AND DISTRIBUTED WITHOUT THE PRIOR PERMISSION OF RICOH AMERICAS CORPORATION.

All product names, domain names or product illustrations, including desktop images, used in this document are trademarks, registered trademarks or the property of their respective companies.

They are used throughout this book in an informational or editorial fashion only and for the benefit of such companies. No such use, or the use of any trade name, or web site is intended to convey endorsement or other affiliation with Ricoh products.

WARNING

The Service Manual contains information regarding service techniques, procedures, processes and spare parts of office equipment distributed by Ricoh Americas Corporation. Users of this manual should be either service trained or certified by successfully completing a Ricoh Technical Training Program.

Untrained and uncertified users utilizing information contained in this service manual to repair or modify Ricoh equipment risk personal injury, damage to property or loss of warranty protection.

Ricoh Americas Corporation

LEGEND

PRODUCT CODE	COMPANY		
	LANIER	RICOH	SAVIN
G960	AC230n	Aficio SP 3200SF	SP 3200SF

DOCUMENTATION HISTORY

REV. NO.	DATE	COMMENTS
*	09/2007	Original Printing

G960

TABLE OF CONTENTS

INSTALLATION

1. INSTALLATION.....	1-1
1.1 INSTALLATION REQUIREMENTS	1-1

PREVENTIVE MAINTENANCE

2. PREVENTIVE MAINTENANCE.....	2-1
2.1 PM INTERVALS	2-1

REPLACEMENT AND ADJUSTMENT

3. REPLACEMENT AND ADJUSTMENT	3-1
3.1 GENERAL PRECAUTIONS ON DISASSEMBLY	3-1
3.1.1 CHECK POINTS FOR SERVICING	3-1
3.1.2 RELEASING PLASTIC LATCHES.....	3-1
3.2 EXTERIOR COVER.....	3-2
3.2.1 LEFT AND RIGHT OPERATION PANEL COVER.....	3-2
3.2.2 FRONT COVER	3-3
3.2.3 BY-PASS TRAY	3-5
3.2.4 FACE-UP COVER AND REAR COVER.....	3-6
3.2.5 RIGHT SIDE COVER	3-8
3.2.6 LEFT SIDE COVER.....	3-9
3.3 OPERATION PANEL.....	3-11
3.3.1 OPERATION PANEL UNIT	3-11
3.3.2 OPERATION PANEL BOARD	3-12
3.4 ADF	3-13
3.4.1 ADF UNIT	3-13
3.4.2 ADF COVER.....	3-14
3.4.3 ORIGINAL TRAY	3-14

3.4.4 PICK-UP UNIT.....	3-15
3.4.5 ADF MOTOR UNIT.....	3-15
3.5 SCANNER.....	3-17
3.5.1 SCANNER UNIT.....	3-17
3.5.2 CCD MODULE	3-18
When reassembling the CCD module.....	3-19
3.5.3 SCANNER MOTOR.....	3-20
3.5.4 ADF OPEN SENSOR	3-21
3.5.5 CCD HP (HOME POSITION) SENSOR	3-22
3.6 PAPER FEED AND EXIT	3-23
3.6.1 PICK-UP ROLLER.....	3-23
3.6.2 DUPLEX GUIDE UNIT	3-23
3.6.3 FEED ROLLER.....	3-24
3.6.4 MIDDLE COVER	3-25
3.6.5 FRONT MIDDLE COVER.....	3-25
3.6.6 BY-PASS FEED UNIT	3-26
3.6.7 BY-PASS PICK-UP ROLLER.....	3-26
3.6.8 REGISTRATION CLUTCH AND ROLLER	3-27
3.6.9 FEED AND BY-PASS SOLENOIDS	3-29
3.6.10 EXIT ROLLER.....	3-30
3.7 LASER OPTICS	3-32
3.7.1 LSU	3-32
3.8 IMAGE TRANSFER.....	3-33
3.8.1 TRANSFER ROLLER.....	3-33
3.9 FUSING	3-34
3.9.1 FUSER UNIT.....	3-34
3.9.2 THERMOSTAT	3-34
3.9.3 THERMISTOR.....	3-35
3.9.4 HEAT ROLLER.....	3-35
3.9.5 PRESSURE ROLLER	3-37
3.10 DRIVE.....	3-39
3.10.1 MAIN MOTOR.....	3-39
3.10.2 DUPLEX MOTOR	3-39
3.10.3 EXIT MOTOR.....	3-40
3.11 OTHERS.....	3-42
3.11.1 DUPLEX AND MAIN FAN MOTORS	3-42
3.11.2 MAIN BOARD	3-42

Connector Location.....	3-43
3.11.3 MODEM BOARD	3-43
3.11.4 SPEAKER.....	3-44
3.11.5 USB HOST BOARD.....	3-44
3.11.6 CONNECTION BOARD	3-45
Connector Location.....	3-45
3.11.7 TERMINAL BOARD	3-45
3.11.8 POWER SUPPLY BOARD.....	3-46
3.11.9 HIGH VOLTAGE POWER SUPPLY BOARD.....	3-47

TROUBLESHOOTING

4. TROUBLESHOOTING	4-1
4.1 PROCEDURE OF CHECKING SYMPTOMS	4-1
4.2 DISPLAY SCREEN AND ERROR MESSAGES	4-2
4.2.1 DISPLAY SCREEN	4-2
4.2.2 ERROR MESSAGES	4-2
4.3 PAPER FEEDING PROBLEMS.....	4-3
4.3.1 WRONG PRINT POSITION.....	4-3
4.3.2 JAM 0	4-4
4.3.3 JAM 1	4-4
4.3.4 JAM 2	4-5
4.3.5 DUPLEX JAM 1	4-6
4.3.6 DUPLEX JAM 0	4-7
4.3.7 MULTI-FEEDING.....	4-8
4.3.8 PAPER ROLLED IN THE FUSING UNIT	4-8
4.3.9 PAPER ROLLED ON THE OPC DRUM	4-9
4.3.10 DEFECTIVE ADF.....	4-9
4.4 PRINTING PROBLEMS (MALFUNCTIONS).....	4-10
4.4.1 FUSING UNIT ERROR.....	4-10
4.4.2 LSU (LASER SCANNING UNIT) ERROR	4-10
4.4.3 DEFECTIVE OPERATION (LCD WINDOW ****) DISPLAY	4-11
4.4.4 DEFECTIVE LCD OPERATION	4-11
4.4.5 NONFUNCTIONING OF THE FUSING GEAR DUE TO MELTING.....	4-11
4.4.6 PAPER EMPTY	4-12
4.4.7 PAPER EMPTY WITHOUT INDICATION.....	4-12
4.4.8 DOOR OPEN.....	4-13

4.4.9	NO BEEP SOUND WHEN THE DOOR IS OPEN	4-13
4.4.10	DEFECTIVE MOTOR OPERATION	4-13
4.4.11	NO POWER.....	4-14
4.4.12	CURVED VERTICAL LINE	4-14
4.5	PRINTING QUALITY PROBLEMS	4-15
4.5.1	VERTICAL BLACK LINE AND BAND.....	4-15
4.5.2	VERTICAL WHITE LINE	4-15
4.5.3	HORIZONTAL BLACK BAND.....	4-16
4.5.4	BLACK/WHITE SPOT	4-17
4.5.5	LIGHT IMAGE	4-18
4.5.6	DARK IMAGE OR BLACK PAGE	4-19
4.5.7	UNEVEN DENSITY	4-19
4.5.8	BACKGROUND.....	4-20
4.5.9	GHOST (1)	4-21
4.5.10	GHOST (2).....	4-22
4.5.11	GHOST (3).....	4-22
4.5.12	GHOST (4).....	4-23
4.5.13	STAINS ON THE FACE OF PAGE.....	4-24
4.5.14	STAINS ON THE BACK OF PAGE.....	4-24
4.5.15	BLANK PAGE PRINT OUT (1).....	4-25
4.5.16	BLANK PAGE PRINT OUT (2).....	4-26
4.6	FAX AND PHONE PROBLEMS	4-27
4.6.1	NO DIAL TONE	4-27
4.6.2	DEFECTIVE MF DIAL	4-27
4.6.3	DEFECTIVE FAX FORWARD/RECEIVE	4-28
4.6.4	DEFECTIVE FAX FORWARD	4-28
4.6.5	DEFECTIVE FAX RECEIVE (1)	4-29
4.6.6	DEFECTIVE FAX RECEIVE (2)	4-29
4.6.7	DEFECTIVE FAX RECEIVE (3)	4-29
4.6.8	DEFECTIVE FAX RECEIVE (4)	4-30
4.6.9	DEFECTIVE AUTOMATIC RECEIVING.....	4-30
4.7	COPY PROBLEMS.....	4-31
4.7.1	WHITE COPY.....	4-31
4.7.2	BLACK COPY.....	4-31
4.7.3	ABNORMAL NOISE	4-31
4.7.4	DEFECTIVE IMAGE QUALITY.....	4-32
4.8	SCANNING PROBLEMS.....	4-33

4.8.1 DEFECTIVE PC SCAN	4-33
4.8.2 DEFECTIVE IMAGE QUALITY OF PC SCAN.....	4-33
4.9 NETWORK PROBLEMS	4-34
4.9.1 GENERAL PROBLEMS	4-34
4.9.2 MACINTOSH PROBLEMS	4-35
4.9.3 WINDOWS PROBLEMS	4-36
4.9.4 SYNCTHRU INSTALLATION PROBLEMS	4-38
4.10 PERIODIC DEFECTIVE IMAGE	4-40

SERVICE TABLES

5. SERVICE TABLES.....	5-1
5.1 TECH MODE	5-1
5.1.1 HOW TO ENTER TECH MODE	5-1
To enter Tech Mode.....	5-1
To exit the Tech Mode	5-1
5.1.2 TECH MODE.....	5-1
5.1.3 DATA SETUP	5-3
Send Level.....	5-3
Dial Mode.....	5-3
Modem Speed.....	5-3
Error Rate	5-3
Clear All Memory	5-3
Flash Upgrade	5-4
5.1.4 MACHINE TESTS	5-4
Switch Test	5-4
Modem Test.....	5-4
DRAM Test	5-4
ROM Test	5-4
Pattern Test	5-4
Shading Test.....	5-4
5.1.5 REPORTS	5-5
Protocol List.....	5-5
Configuration Report.....	5-5
5.2 EDC (ENGINE DIAGNOSTIC CONTROL) MODE.....	5-6
5.2.1 EDC SETUP	5-6
5.2.2 OPERATING EDC.....	5-6

Entering EDC	5-6
Exiting EDC.....	5-6
5.2.3 COVER OPEN/CLOSE STATUS	5-6
Usage	5-6
Function	5-7
5.2.4 SENSOR STATUS	5-7
Usage	5-7
Function	5-7
5.2.5 MOTOR TEST	5-8
Usage	5-8
5.2.6 FAN TEST	5-9
Usage	5-9
Function	5-10
5.2.7 CLUTCH/SOLENOID	5-10
Usage	5-10
Function	5-10
5.2.8 FUSER CONTROL.....	5-11
Usage	5-11
5.2.9 LSU	5-12
Usage	5-12
5.2.10 BIAS CONTROL	5-12
Usage	5-13
Function	5-13
5.3 FIRMWARE DOWNLOAD	5-14
5.3.1 FIRMWARE UPGRADE	5-14
Local	5-14
Remote	5-15

DETAILED SECTION DESCRIPTIONS

6. DETAILED DESCRIPTIONS	6-1
6.1 SYSTEM DESCRIPTIONS	6-1
6.1.1 FEEDING SECTION.....	6-1
6.1.2 TRANSFER UNIT.....	6-1
6.1.3 DRIVER UNIT.....	6-1
6.1.4 FUSING UNIT.....	6-1
Overheat protection:	6-1

Safety device	6-2
6.1.5 LSU (LASER SCANNING UNIT)	6-2
6.1.6 SCANNER	6-2
6.1.7 TONER CARTRIDGE	6-3
6.1.8 DUPLEX UNIT	6-4
6.1.9 OPTIONAL TRAY (SCF)	6-4
6.1.10 CONTROLLER	6-4
6.1.11 ELECTRICAL COMPONENTS	6-4
Input Circuit Sensor	6-4
By-pass Sensor	6-4
Paper Feed Sensor	6-4
Paper Exit Sensor	6-5
Cover Open Sensor	6-5
DC Fan / Solenoid Control	6-5
Motor Control	6-5
6.1.12 SMPS AND HVPS BOARD	6-5
SMPS (Switching Mode Power Supply)	6-5

SPECIFICATIONS

7. SPECIFICATIONS	7-1
7.1 GENERAL SPECIFICATIONS	7-1
7.1.1 GENERAL SPECIFICATIONS	7-1
7.1.2 PRINTER	7-3
7.1.3 SCANNER	7-4
7.1.4 COPIER	7-5
7.1.5 TELEPHONE	7-6
7.1.6 FAX	7-7

APPENDIX

8. APPENDIX	8-1
8.1 BLOCK DIAGRAM	8-1
8.1.1 SYSTEM BLOCK DIAGRAM	8-1

Read This First

Precautions

In order to prevent accidents and to prevent damage to the equipment, please read the precautions listed below carefully before servicing the machine and follow them closely.

Safety Warning

1. Only to be serviced by appropriately qualified service engineers.
 - High voltages and lasers inside this product are dangerous. This machine should only be serviced by a suitably trained and qualified service engineer.
2. Use only genuine replacement parts
 - There are no user serviceable parts inside the machine. Do not make any unauthorized changes or additions to the machine, these could cause the machine to malfunction and create electric shock or fire hazards.
3. Laser Safety Statement
 - The Machine is certified in the U.S. to conform to the requirements of DHHS 21 CFR, chapter 1 Subchapter J for Class 1(1) laser products, and elsewhere, it is certified as a Class I laser product conforming to the requirements of IEC 825. Class I laser products are not considered to be hazardous. The laser system and machine are designed so there is never any human access to laser radiation above a Class I level during normal operation, user maintenance, or prescribed service condition.

WARNING

- Never operate or service the machine with the protective cover removed from Laser/Scanner assembly. The reflected beam, although invisible, can damage your eyes. When using this product, these basic safety pre-cautions should always be followed to reduce risk of fire, electric shock, and injury to persons.



CAUTION FOR SAFETY

Toxic material

This product contains toxic materials that could cause illness if ingested.

1. If the LCD control panel is damaged, it is possible for the liquid inside to leak. This liquid is toxic. Contact with the skin should be avoided, wash any splashes from eyes or skin immediately and contact your doctor. If the liquid gets into the mouth or is swallowed, see a doctor immediately.
2. Please keep toner cartridges away from children. The toner powder contained in the toner cartridge may be harmful and if swallowed, you should contact a doctor.

Electric Shock and Fire Safety Precautions

Failure to follow the following instructions could cause electric shock or potentially cause a fire.

1. Use only the correct voltage, failure to do so could damage the machine and potentially cause a fire or electric shock.
2. Use only the power cable supplied with the machine. Use of an incorrectly specified cable could cause the cable to overheat and potentially cause a fire.

Assembly/ Disassembly Precautions

Replace parts carefully, always use genuine parts. Take care to note the exact location of parts and also cable routing before dismantling any part of the machine. Ensure all parts and cables are replaced correctly.

Please carry out the following procedures before dismantling the machine or replacing any parts.

- (1) Check the contents of the machine memory and make a note of any user settings. These will be erased if the main board or network card is replaced.
- (2) Ensure that power is disconnected before servicing or replacing any electrical parts.
- (3) Disconnect machine interface cables and power cables.
- (4) Only use approved spare parts. Ensure that part number, product name, any voltage, current or temperature rating are correct.
- (5) When removing or re-fitting any parts do not use excessive force, especially when fitting screws into plastic.
- (6) Take care not to drop any small parts into the machine.
- (7) Handling of the OPC Drum
 - The OPC Drum can be irreparably damaged if it is exposed to light. Take care not to expose the OPC Drum either to direct sunlight or to fluorescent or incandescent room lighting. Exposure for as little as five minutes can damage the surface's photoconductive properties and will result in print quality degradation. Take extra care when servicing the machine. Remove the OPC Drum and store it in a black bag or other lightproof container. Take care when working with the covers (especially the top cover) open as light is admitted to the OPC area and can damage the OPC Drum.
 - Take care not to scratch the green surface of OPC Drum Unit. If the green surface of the Drum Cartridge is scratched or touched the print quality will be compromised.

Disregarding this warning may cause bodily injury

1. **Be careful with the high temperature part.**

The fuser unit works at a high temperature. Use caution when working on the machine. Wait for the fuser to cool down before disassembly.
2. **Do not put fingers or hair into the rotating parts.**

When operating a machine, do not put hand or hair into the rotating parts (Paper feeding entrance, motor, fan, etc.). This may cause harm.

INSTALLATION

TAB
POSITION 1

PREVENTIVE MAINTENANCE

TAB
POSITION 2

REPLACEMENT AND ADJUSTMENT

TAB
POSITION 3

TROUBLESHOOTING

TAB
POSITION 4

SERVICE TABLES

TAB
POSITION 5

DETAILED DESCRIPTIONS

TAB
POSITION 6

SPECIFICATIONS

TAB
POSITION 7

APPENDIX

TAB
POSITION 8

INSTALLATION

1. INSTALLATION

1.1 INSTALLATION REQUIREMENTS

This product is fully user-installable.

Refer to the User's Guide

PREVENTIVE MAINTENANCE

2. PREVENTIVE MAINTENANCE

2.1 PM INTERVALS

There are no PM parts in this machine.

 Note

- There is essentially no PM required on this product.
- The 4 yield parts listed below would need to be replaced in cases where their yield is near, however, given the ACV (Average Copy Volume) on this product, the “yield parts^{*1}” are expected to outlast the machine.

*1 **“Yield Parts”**: Parts whose expected yield is longer than the machine lifetime when taking into consideration the machine’s ACV.

Description	Expected Yield	Q'ty/unit
Pick-up Roller	150K prints	1
Friction Pad Ass'y	150K prints	1
Transfer Roller	70K prints	1
Fuser Unit	80K prints	1

REPLACEMENT AND ADJUSTMENT

3. REPLACEMENT AND ADJUSTMENT

3.1 GENERAL PRECAUTIONS ON DISASSEMBLY

When you disassemble and reassemble components, you must use extreme caution. The close proximity of cables to moving parts makes proper routing a must. If components are removed, any cables disturbed by the procedure must be restored as close as possible to their original positions. Before removing any component from the machine, note the cable routing that will be affected.

3.1.1 CHECK POINTS FOR SERVICING

Whenever servicing the machine, you must perform as follows:

1. Check to verify that documents are not stored in memory.
2. Be sure to remove the print cartridge before you disassemble parts.
3. Unplug the power cord.
4. Use a flat and clean surface.
5. Replace only with authorized components.
6. Do not force plastic-material components.
7. Make sure all components are in their proper position.

3.1.2 RELEASING PLASTIC LATCHES

Many of the parts are held in place with plastic latches. The latches break easily; release them carefully. To remove such parts, press the hook end of the latch away from the part to which it is latched.

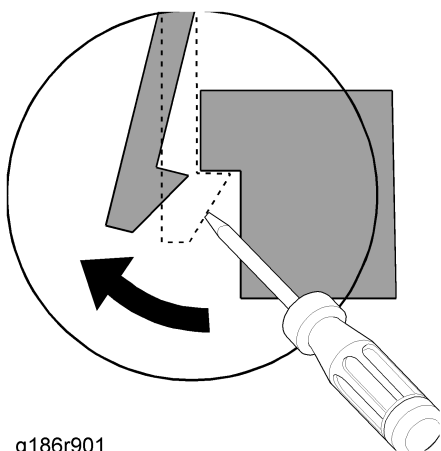

g186r901

3.2 EXTERIOR COVER

3.2.1 LEFT AND RIGHT OPERATION PANEL COVER

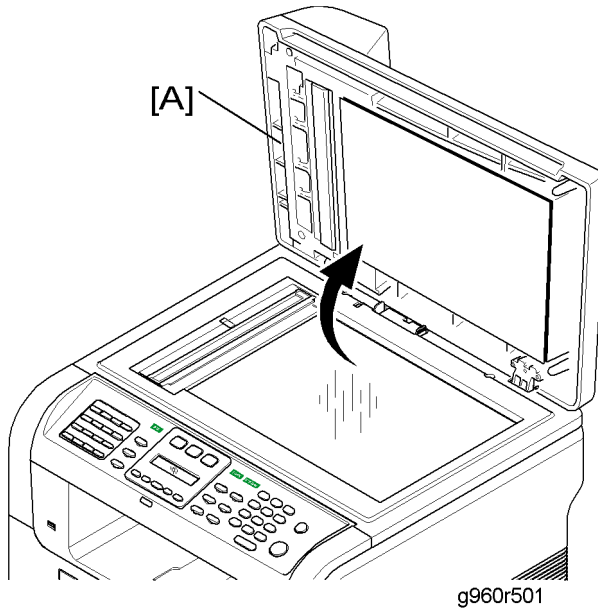

1. Open the ADF unit [A].
2. Open the front cover.

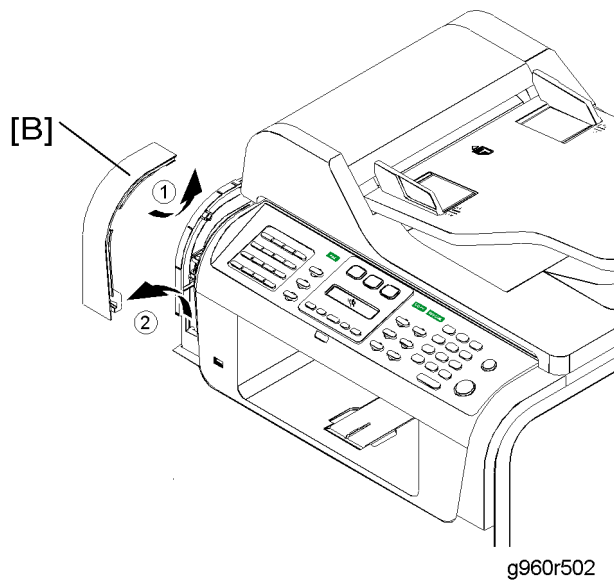

3. Remove the left operation panel cover [B].

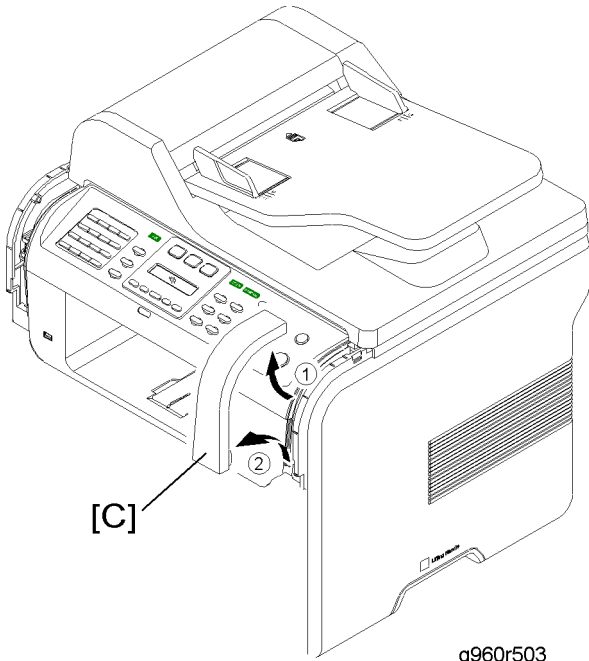

g960r503

- 4. Remove the right operation panel cover [C].

3.2.2 FRONT COVER

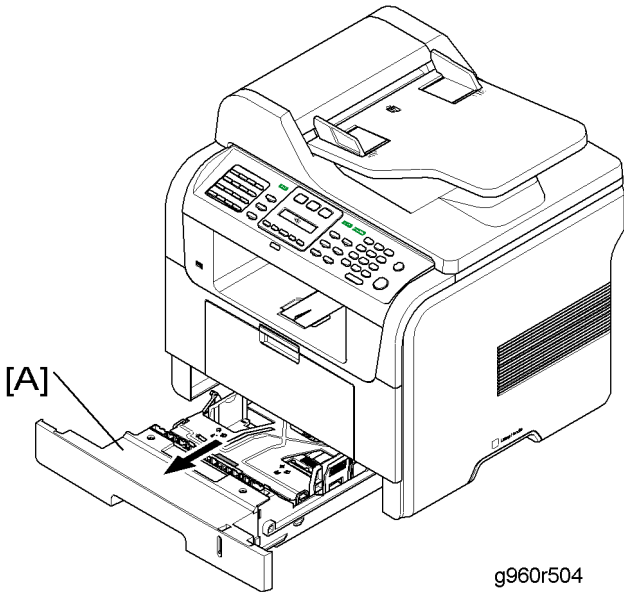

g960r504

- 1. Pull out the paper tray. [A].

Exterior Cover

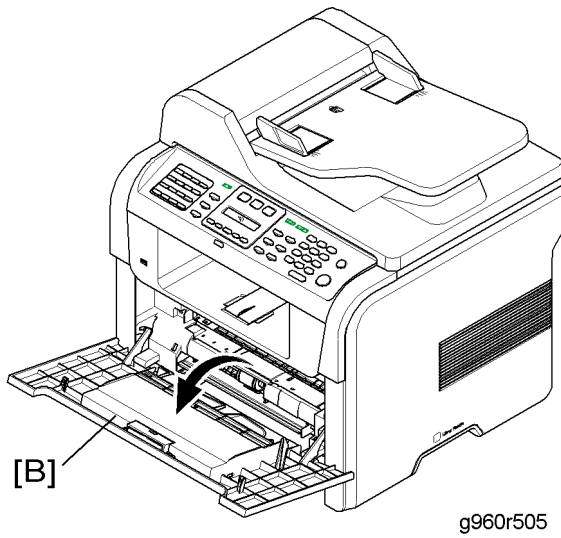

2. Open the front cover [B].

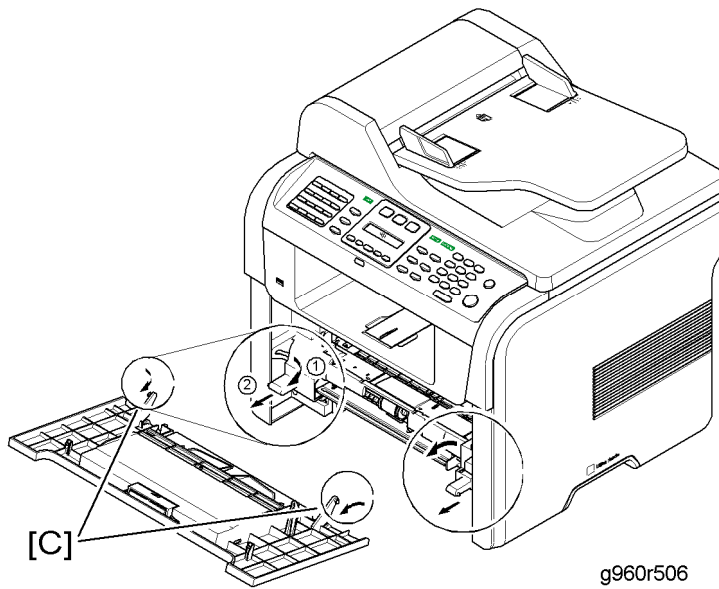

3. Push both links [C] to the inside of the machine, and then release them.
4. Remove the front cover.

3.2.3 BY-PASS TRAY

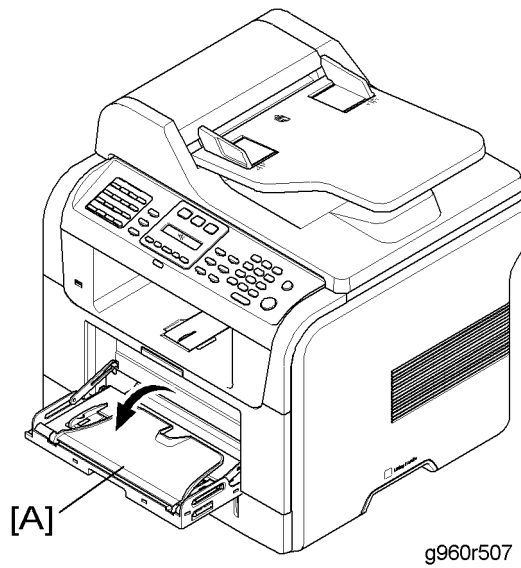

1. Open the bypass tray [A].

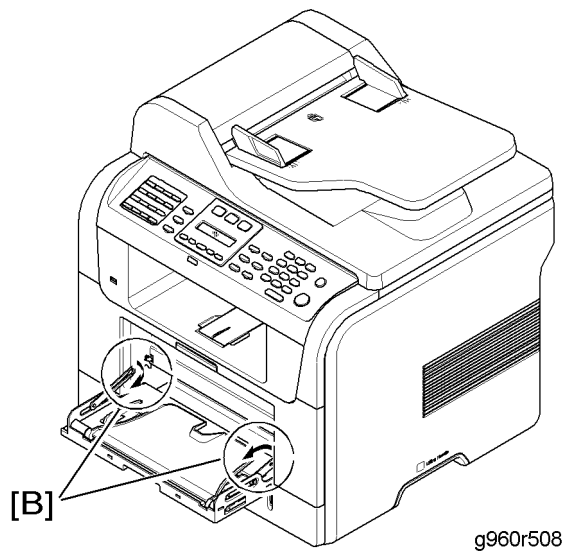

2. Push both links [B] to the inside of the machine, and then release them.

Exterior Cover

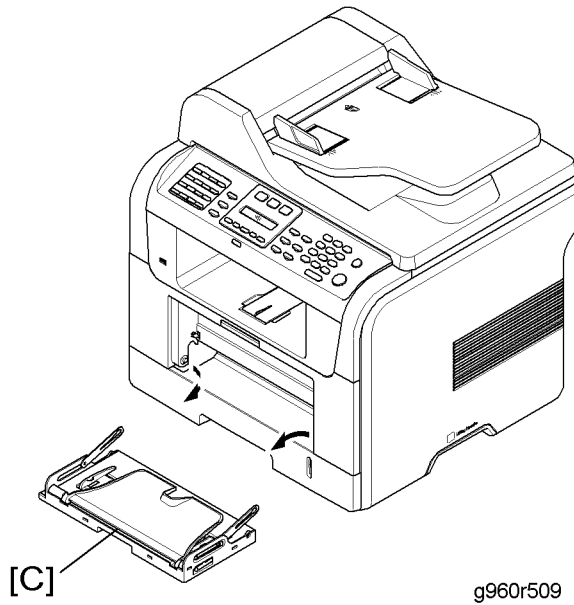

3. Remove the by-pass tray [C].

3.2.4 FACE-UP COVER AND REAR COVER

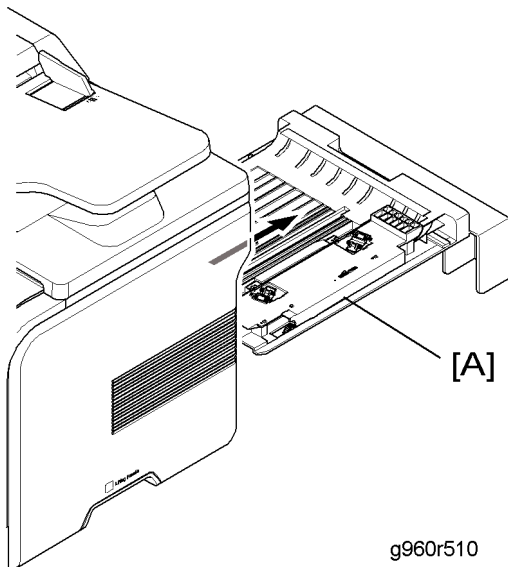

1. Take out the duplex unit [A].

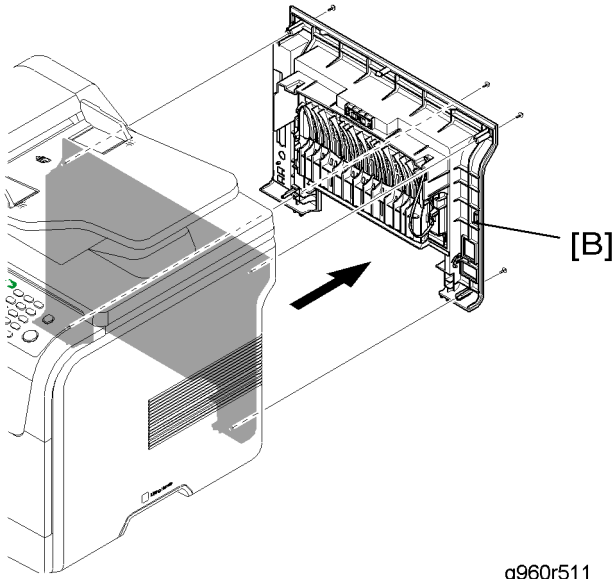

g960r511

- 2. Remove the rear cover with the face-up cover [B] (⚙ x 4).

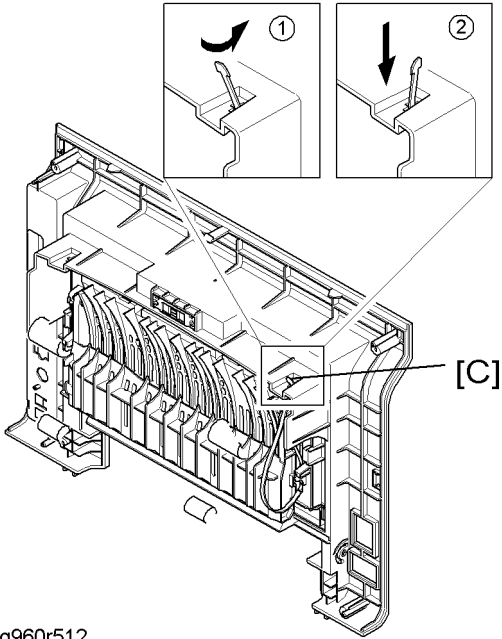

g960r512

- 3. Release strap [C] as shown above.

Exterior Cover

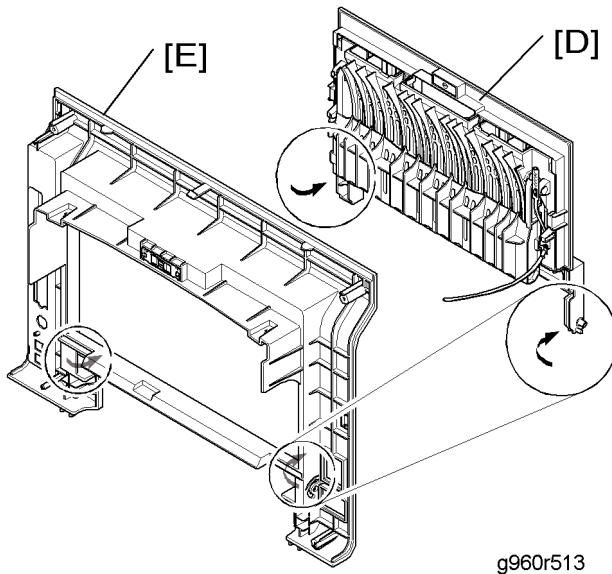

4. Remove the face-up cover [D].
5. Rear cover [E]

3.2.5 RIGHT SIDE COVER

1. Before you remove the right side cover, you should remove:
 - Front cover (➔ Sec. 3.2.2 "Front Cover")
 - Rear cover with face-up cover (➔ Sec. 3.2.4 "Face-up Cover and Rear Cover")

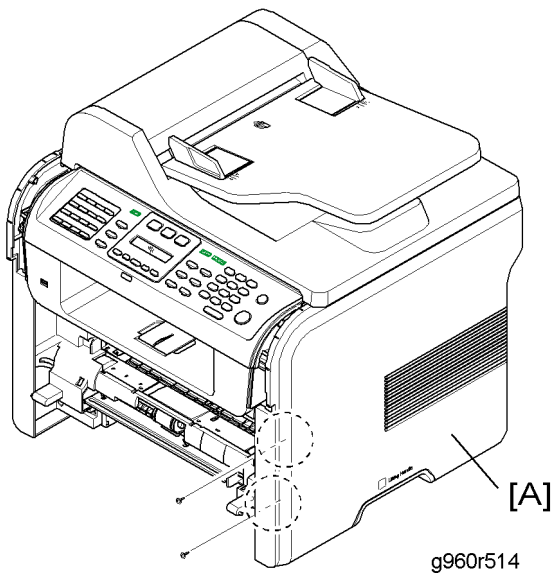

2. Remove the two screws from the right side cover [A].

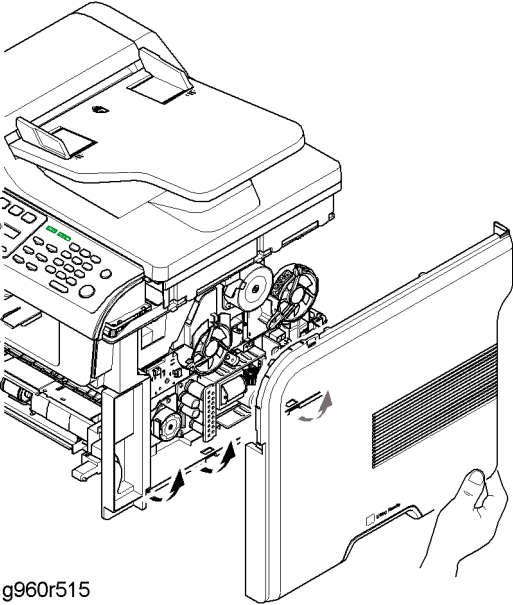

- 3. Take off the right side cover.

3.2.6 LEFT SIDE COVER

- 1. Before you remove the left side cover, you should remove:
 - Front cover (➔Sec. 3.2.2 "Front Cover")
 - Rear cover with face-up cover (➔Sec. 3.2.4 "Face-up Cover and Rear Cover")

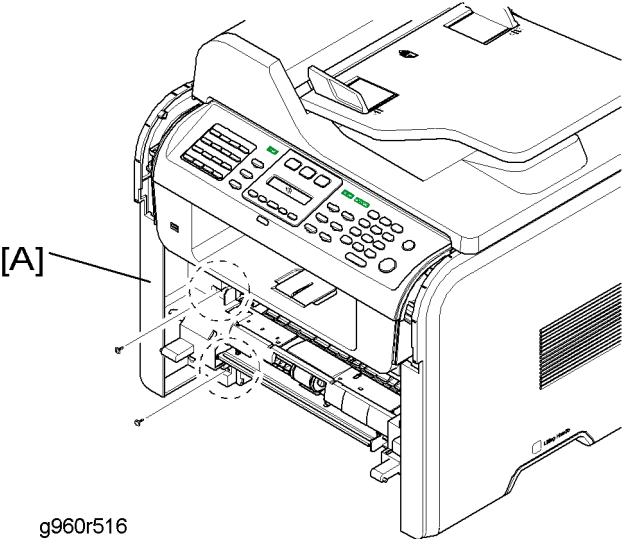

- 2. Remove the two screws from the left side cover [A].

Exterior Cover

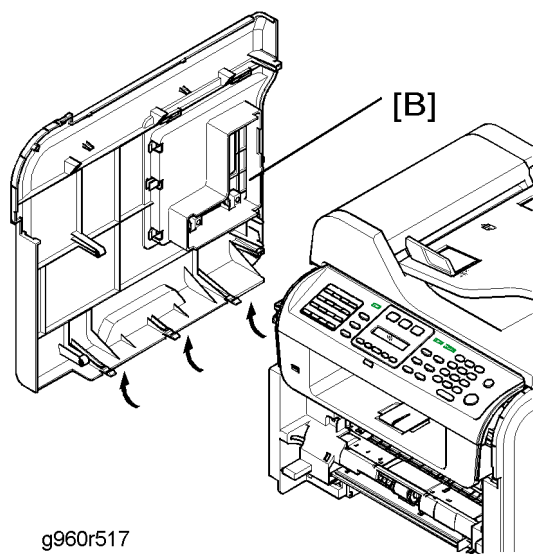

g960r517

3. Take off the left side cover [B].

3.3 OPERATION PANEL

3.3.1 OPERATION PANEL UNIT

1. Before you remove the operation panel unit, you should remove:
 - Left and right operation panel cover (➔ 3.2.1 "Left and Right Operation Panel Cover")

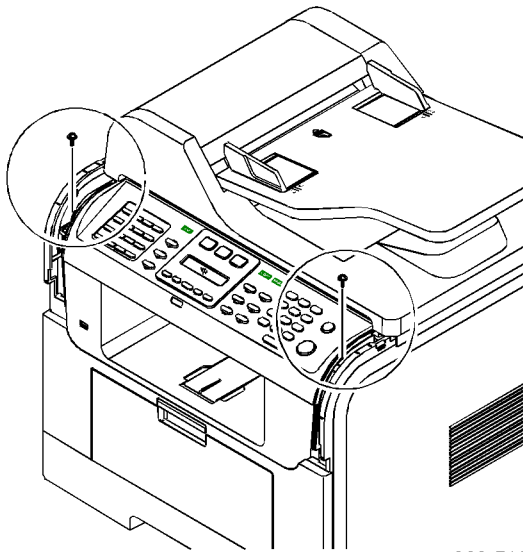

g960r518

2. Remove the two screws on the operation panel unit as shown above.

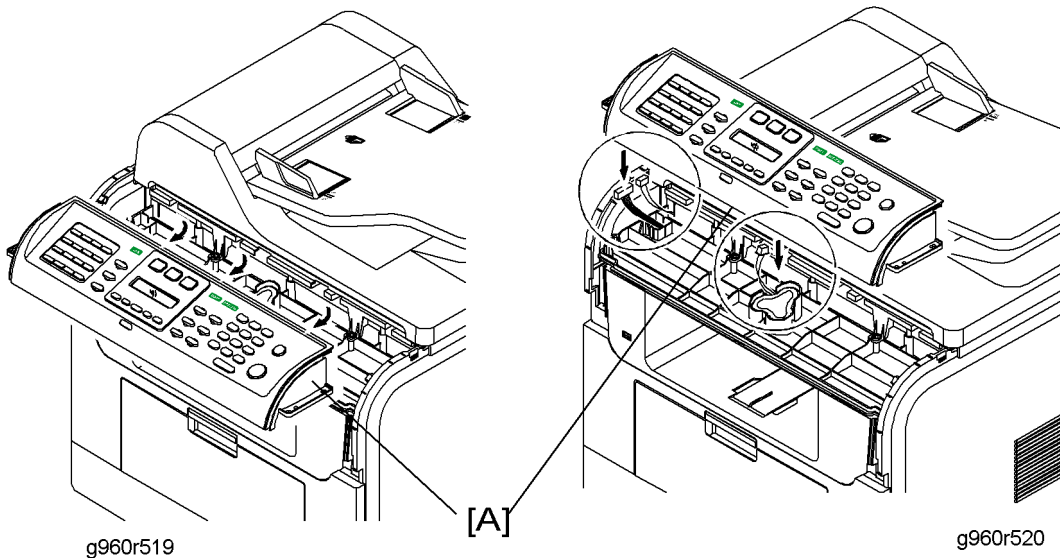

g960r519

g960r520

3. Remove the operation panel unit [A] (☞ x 3).

Operation Panel

3.3.2 OPERATION PANEL BOARD

1. Before you remove the operation panel board, you should remove:
 - Left and right operation panel cover (↔Sec. 3.2.1 "Left and Right Operation Panel Cover")
 - Operation panel unit (↔Sec. 3.3.1 "Operation Panel Unit")

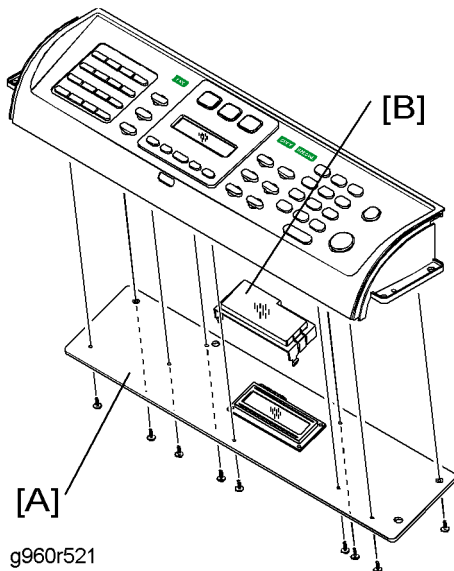

2. Remove the operation panel board [A] (⚙ x 9).
3. Remove the LCD cover [B].

3.4 ADF

3.4.1 ADF UNIT

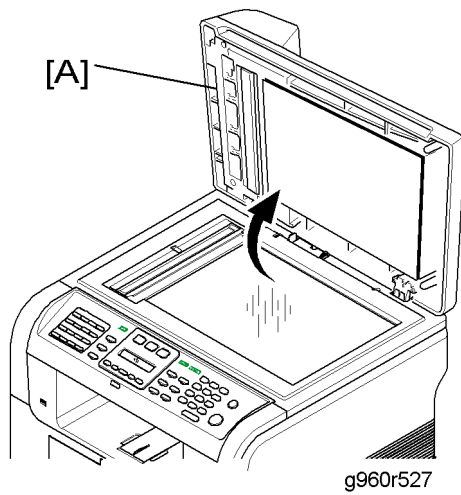

1. Open the ADF unit [A].

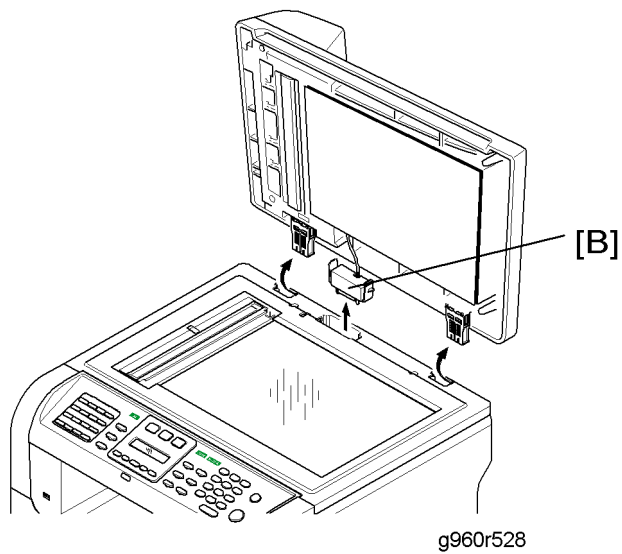

2. Disconnect the ADF cable [B] and take out the ADF unit.

ADF

3.4.2 ADF COVER

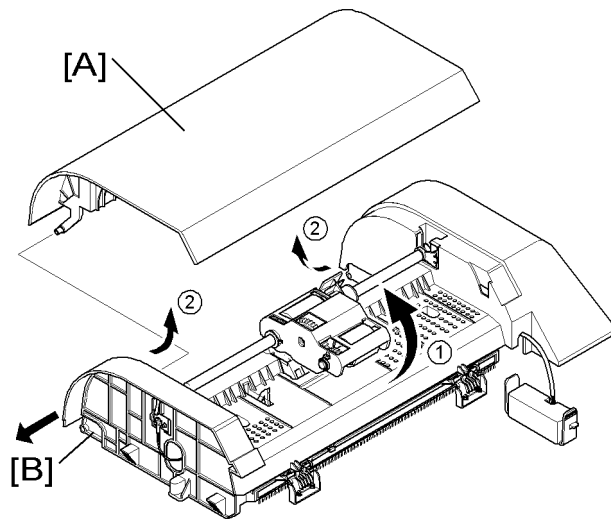

g960r529

1. Open the ADF cover [A].
2. Push the shaft holder [B] in the arrow direction as shown above.
3. Remove the ADF cover.

3.4.3 ORIGINAL TRAY

1. Before you remove the original tray, you should remove:
 - ADF unit (→Sec. 3.4.1 "ADF Unit")

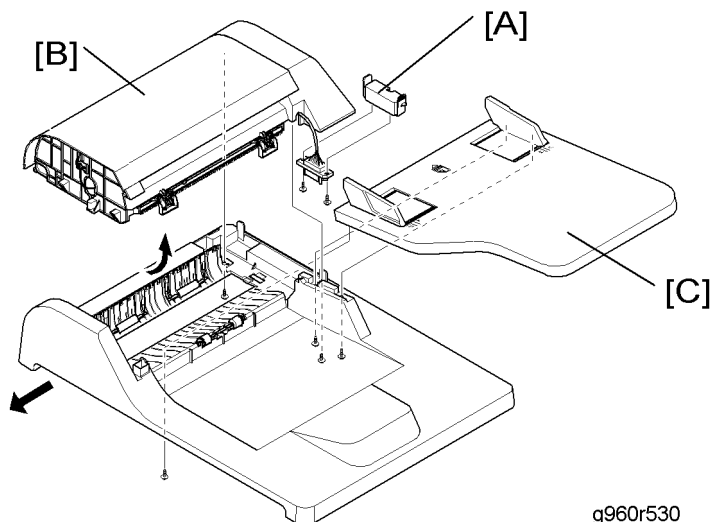

g960r530

2. Remove the ADF cable cover [A] (⚙ x 2).
3. Remove the ADF drive unit [B] (⚙ x 2).
4. Remove the original tray [C] (⚙ x 3).

3.4.4 PICK-UP UNIT

1. Open the ADF cover

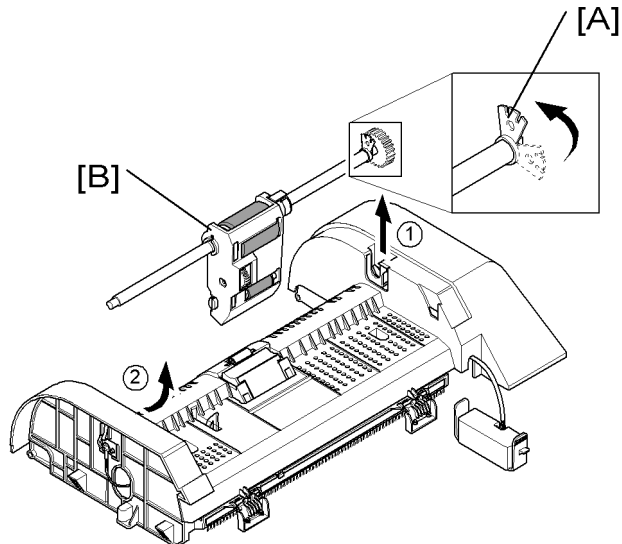

g960r531

2. Release the lock [A] as shown above.
3. Remove the pick-up unit [B].

3.4.5 ADF MOTOR UNIT

1. Before you remove the ADF motor unit, you should remove:
 - ADF drive unit (→ Sec. 3.4.3 "Original Tray")

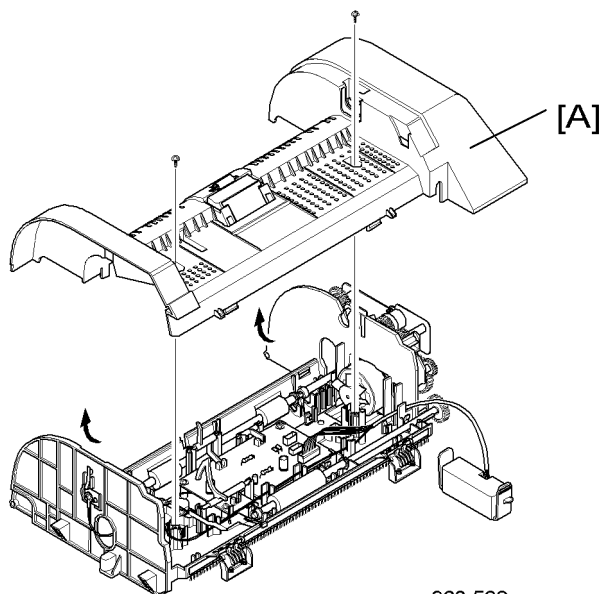

g960r532

2. Remove the ADF upper guide [A] (⌀ x 2).

ADF

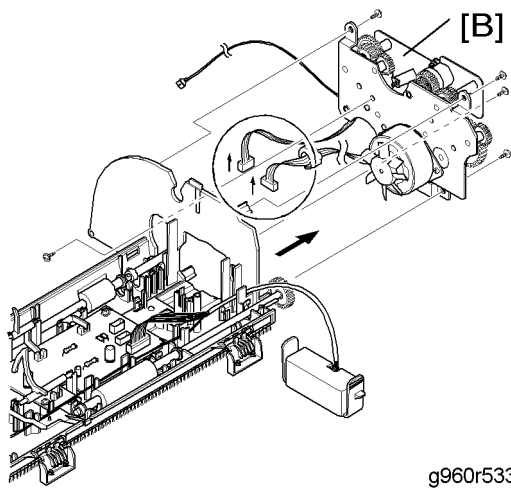

g960r533

3. Remove the ADF motor unit [B] (⚙️ x 5, 🔌 x 2)

3.5 SCANNER

3.5.1 SCANNER UNIT

1. Before you remove the scanner unit, you should remove:
 - Left side cover (➔Sec. 3.2.6 "Left Side Cover")
 - Right side cover (➔Sec. 3.2.5 "Right Side Cover")
 - Operation panel unit (➔Sec. 3.3.1 "Operation Panel Unit ")
 - ADF unit (➔Sec. 3.4.1 "ADF Unit")

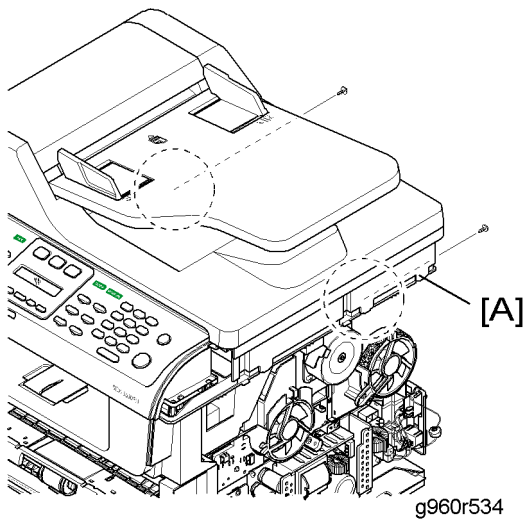

2. Remove the two screws securing the scanner unit [A] as shown above.

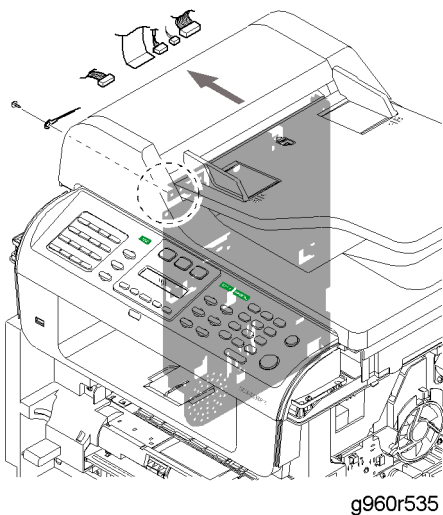

3. Remove the ground cable and all cables (🔧 x 1).

Scanner

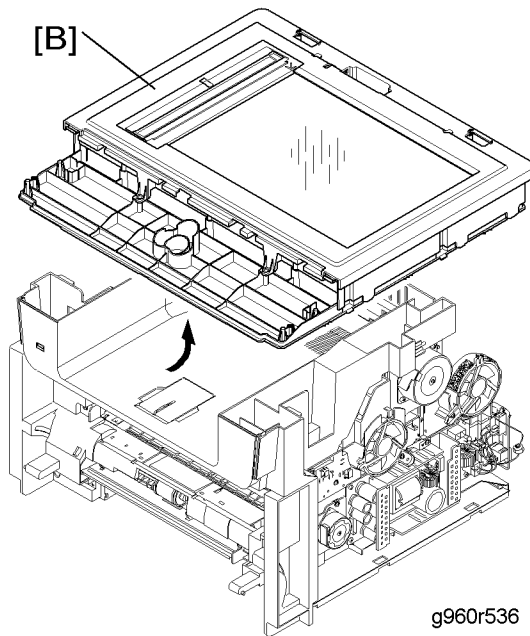

4. Lift the scanner unit [B] in the direction of the arrow as shown above, and then remove it.

3.5.2 CCD MODULE

1. Before you remove the CCD module, you should remove:
 - Scanner unit (→ 3.5.1 "Scanner Unit")

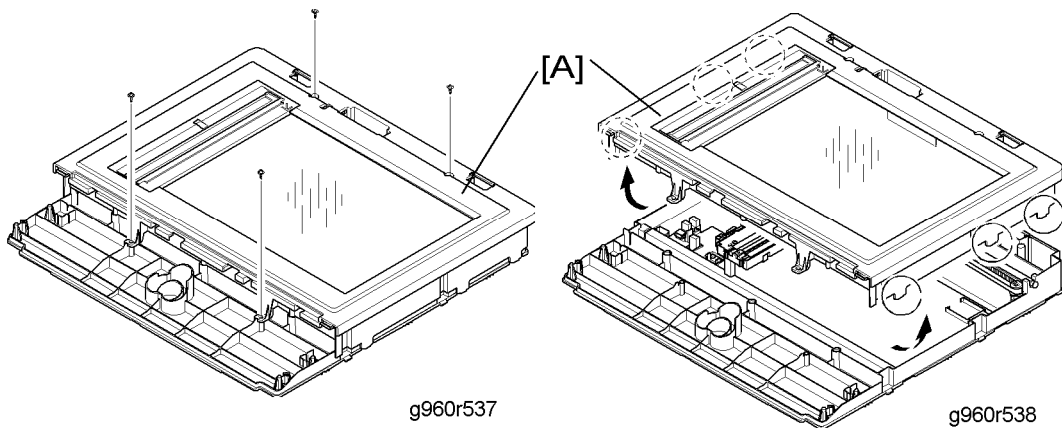

2. Remove the scanner top [A] as shown above (⚙ x 4, hook x 6).

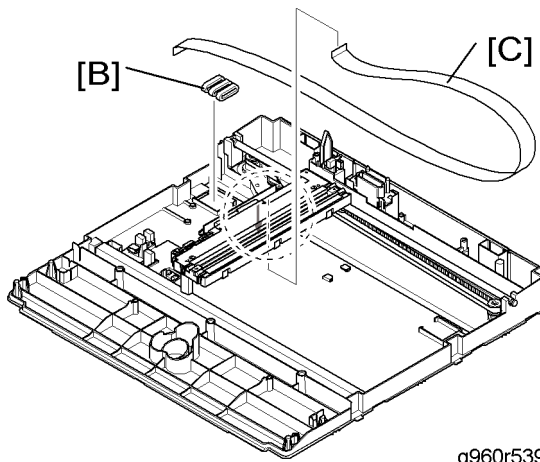

g960r539

3. Remove the core [B] and scanner flat cable [C].

↓ Note

- Remove the CCD flat cable vertically to avoid damaging the pins of the CCD flat cable.

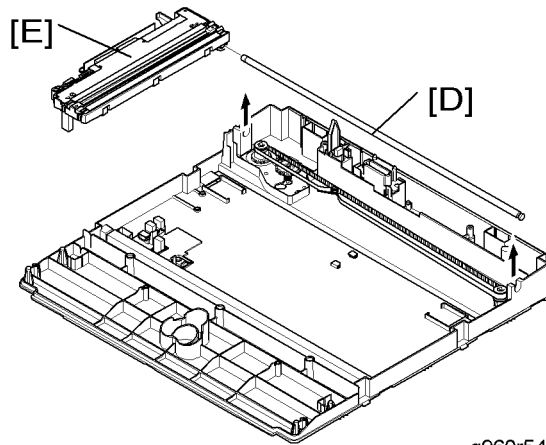

g960r540

4. Pull up the CCD shaft [D], and then take out the CCD module [E].

When reassembling the CCD module

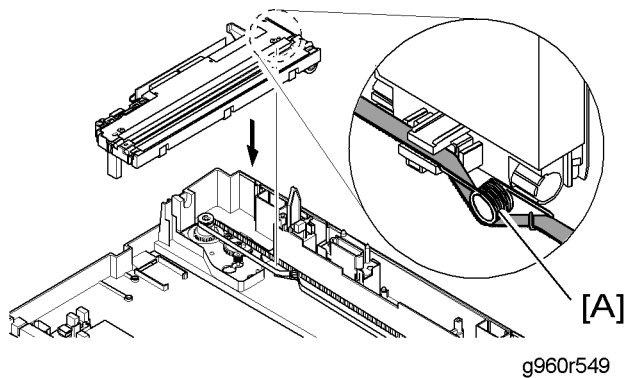

g960r549

1. When installing the scanner belt and belt spring, set the belt spring [A] as close to the

Scanner

right side of the CCD module as possible as shown above.

2. When installing the scanner top, make sure that the actuator of the ADF open sensor comes out from the hole of the scanner top.

3.5.3 SCANNER MOTOR

1. Before you remove the scanner motor, you should remove:
 - Scanner unit (➔ 3.5.1 "Scanner Unit")
 - CCD module (➔ 3.5.2 "CCD Module")

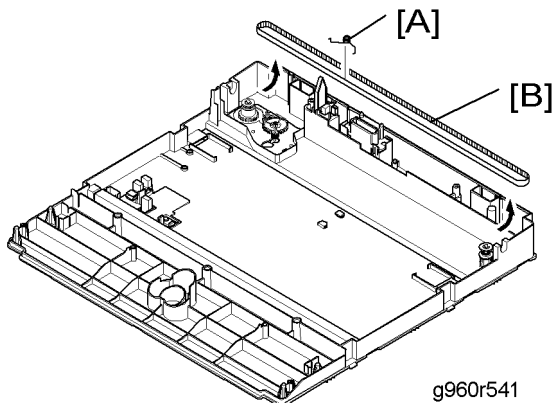

2. Squeeze the belt spring [A] to release the tension of the scanner belt [B], and then lift the scanner belt [B] from the pulleys as shown above.

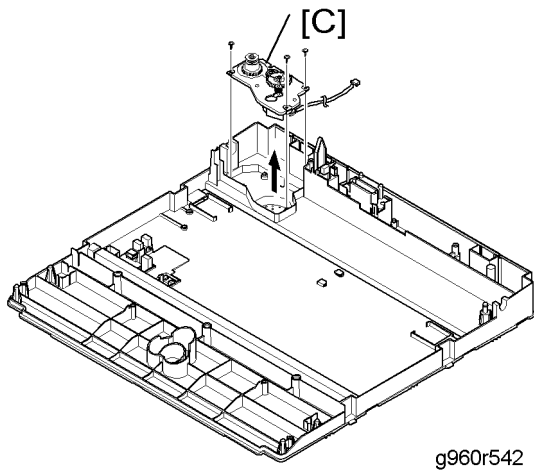

3. Remove the scanner motor unit [C] (⚙ x 3).

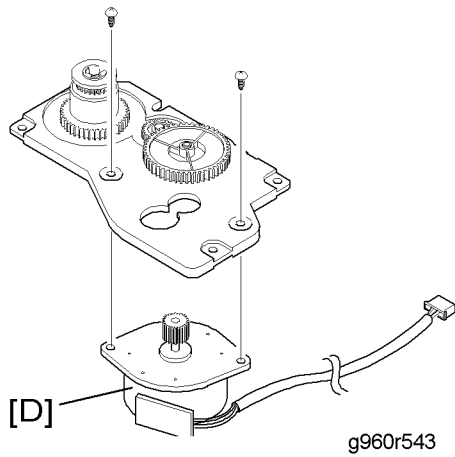

4. Remove the scanner motor [D] (hook x 2).

3.5.4 ADF OPEN SENSOR

1. Before you remove the ADF open sensor, you should remove:
 - Scanner unit (→ Sec. 3.5.1 "Scanner Unit")
 - CCD module (→ 3.5.2 "CCD Module")

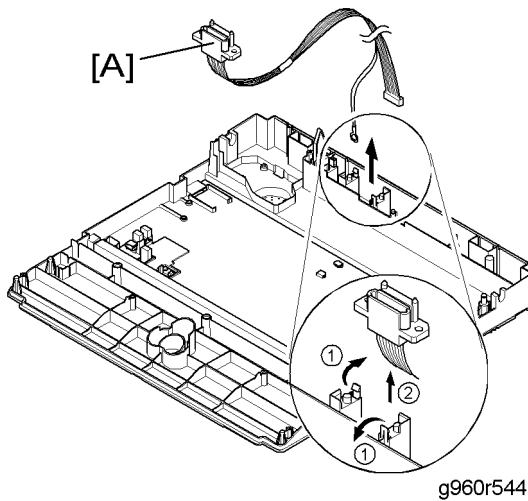

2. Remove the ADF harness [A] (hook x 2)

Scanner

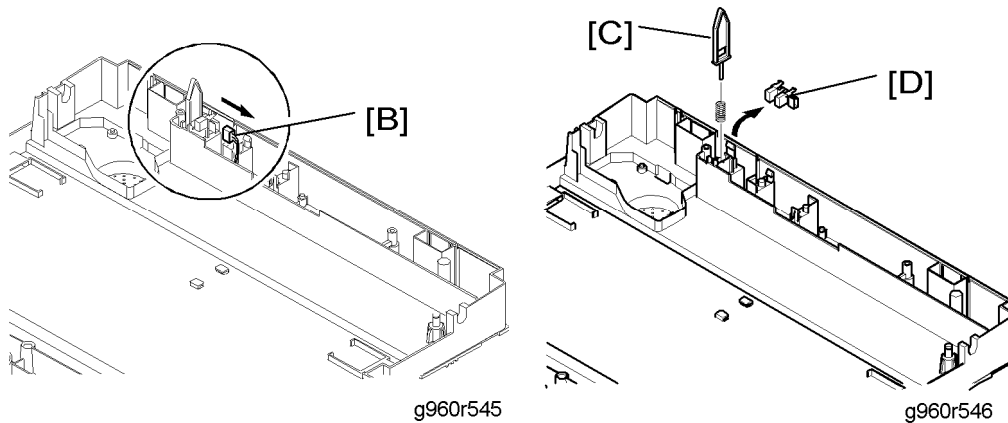

3. Disconnect the connector [B].
4. Remove the actuator [C] (spring x 1), and then the ADF open sensor [D].

3.5.5 CCD HP (HOME POSITION) SENSOR

1. Before you remove the CCD HP sensor, you should remove:
 - Scanner unit (→Sec. 3.5.1 "Scanner Unit")
 - Scanner top (→Sec. 3.5.2 "CCD Module")
2. Slide the CCD module to the right-hand side.

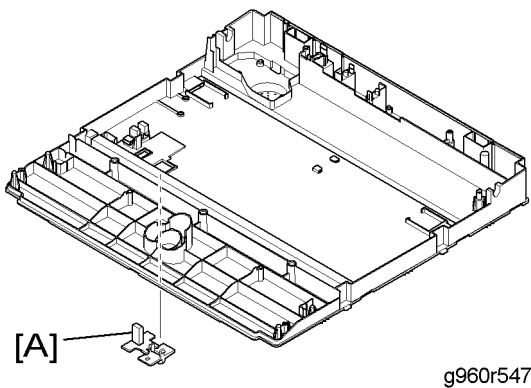

3. Remove the CCD HP sensor holder [A].

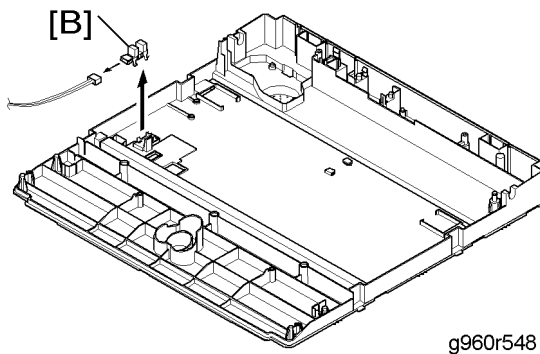

4. Remove the CCD HP sensor [B] (☞ x 1, hooks)

3.6 PAPER FEED AND EXIT

3.6.1 PICK-UP ROLLER

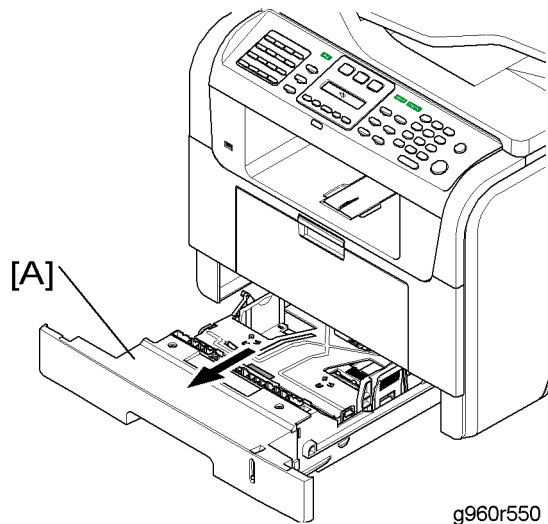

1. Take out the Cassette [A].

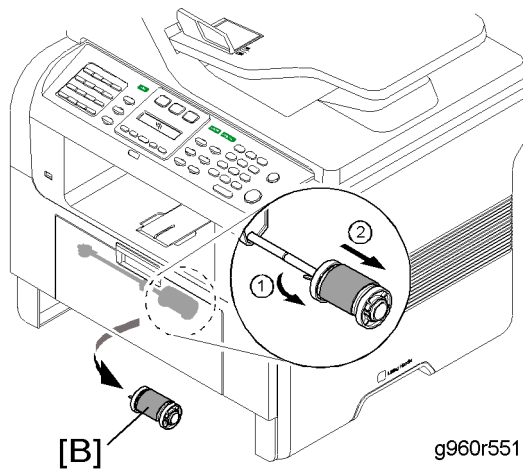

2. Remove the pick-up roller [B].
 - Release the latch ①, and then slide the pick-up roller ② to the right-hand side.

3.6.2 DUPLEX GUIDE UNIT

1. Before you remove the duplex guide, you should remove:
 - Duplex unit (➔Sec. 3.2.4 "Face-up Cover and Rear Cover")
 - Pick-up roller (➔Sec. 3.6.1 "Pick-up Roller")

Paper Feed and Exit

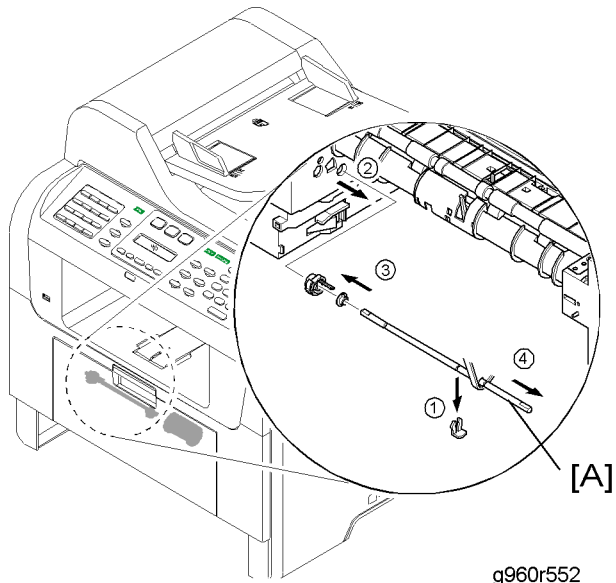

2. Remove the pick-up roller shaft [A].

- Release the clip ring ①.
- Slide the pick-up roller shaft to the right-hand side ②.
- Release the notch of the cam and then remove the cam and bushing ③.
- Remove the pick-up roller shaft ④.

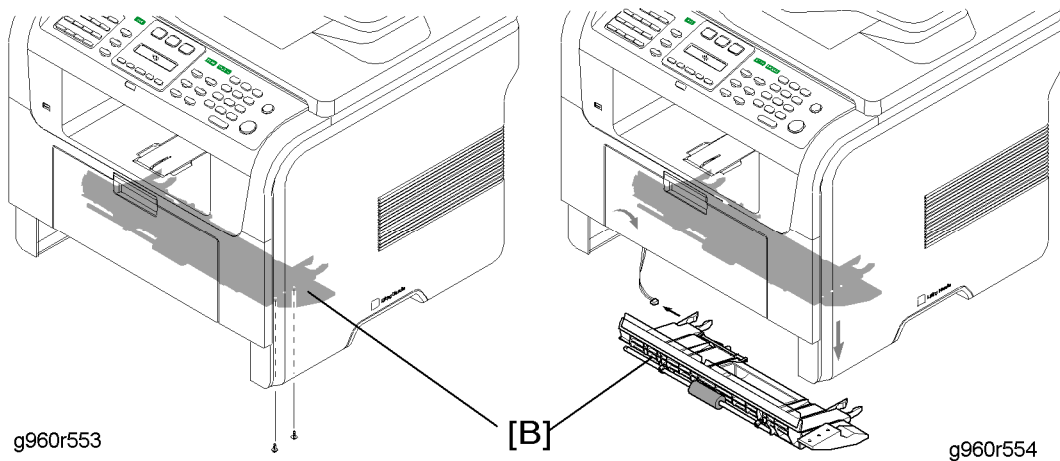

3. Remove the duplex guide unit [B] (⚙ x 2, 📄 x 1).

3.6.3 FEED ROLLER

1. Before you remove the feed roller, you should remove:

- Duplex guide unit (➡Sec. 3.6.2 "Duplex Guide Unit")

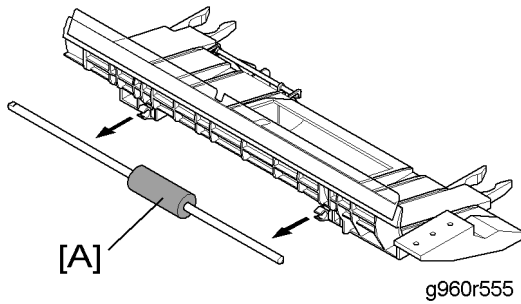

2. Remove the feed roller [A].

3.6.4 MIDDLE COVER

1. Before you remove the middle cover, you should remove:
 - Left side cover (➔Sec. 3.2.6 "Left Side Cover")
 - Right side cover (➔ 3.2.5 "Right Side Cover")
 - Scanner unit (➔ 3.5.1 "Scanner Unit")
 - Main board (➔Sec. 3.11.2 "Main Board")
 - USB host board (➔Sec. 3.11.5 "USB Host Board")

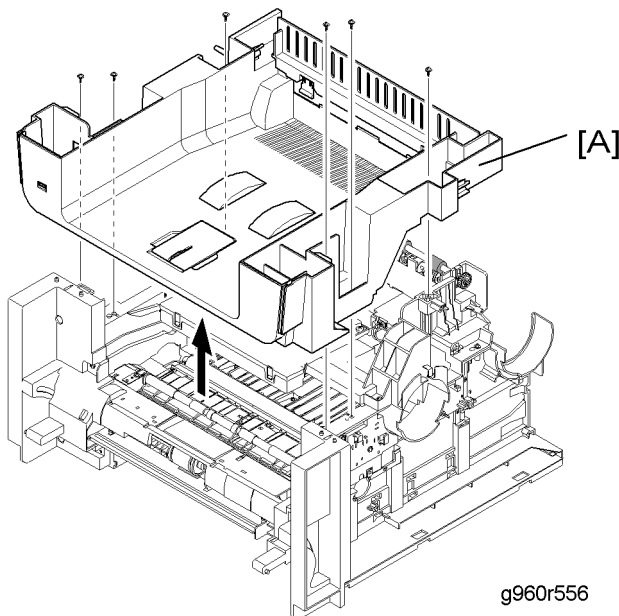

2. Remove the middle cover [A] (⚙ x 6).

3.6.5 FRONT MIDDLE COVER

1. Before you remove the front middle cover, you should remove:
 - Middle cover (➔Sec. 3.6.4 "Middle Cover")

Paper Feed and Exit

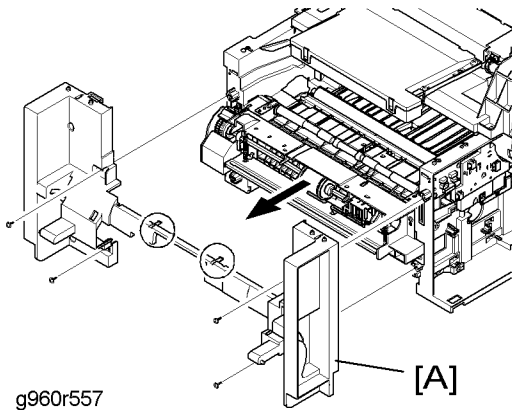

2. Remove the front middle cover [A] (⚙ x 4, hooks)

↓ Note

- Be careful with the front middle cover during replacing, as it is fragile.

3.6.6 BY-PASS FEED UNIT

1. Before you remove the by-pass feed unit, you should remove:
 - Front middle cover (➡Sec. 3.6.4 "Front Middle Cover")

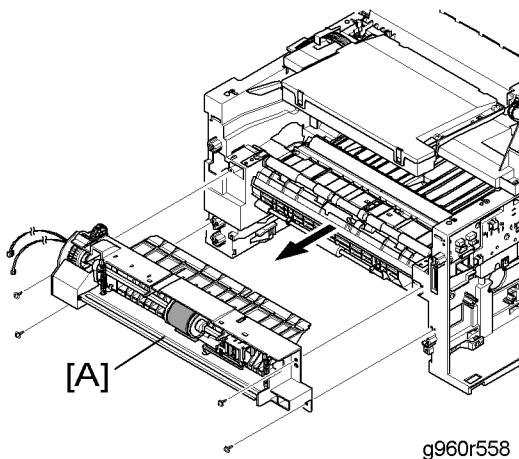

2. Remove the by-pass feed unit [A] (⚙ x 4, ⚙ x 2)

3.6.7 BY-PASS PICK-UP ROLLER

1. Before you remove the by-pass pick-up roller, you should remove :
 - By-pass feed unit (➡Sec. 3.6.6"By-pass Feed Unit")

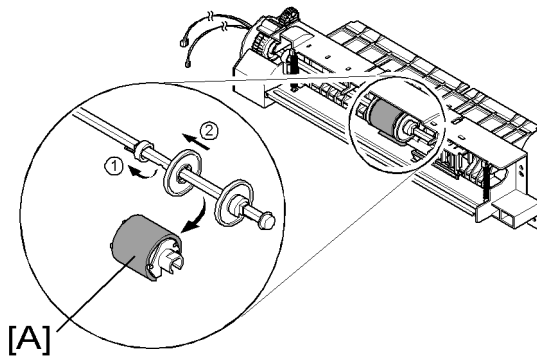

g960r559

2. Remove the by-pass pick-up roller [A]
 - Release the notch and then slide the stopper ① to the left-hand side.
 - Slide the idle cam ② to the left-hand side.

3.6.8 REGISTRATION CLUTCH AND ROLLER

1. Before you remove the registration clutch and roller, you should remove:
 - Pick-up roller (➔Sec. 3.6.1 "Pick-up Roller")
 - Duplex guide unit (➔Sec. 3.6.2 "Duplex Guide Unit")
 - Middle cover (➔Sec. 3.6.4 "Middle Cover")
 - By-pass feed unit (➔Sec. 3.6.6 "By-pass Feed Unit")

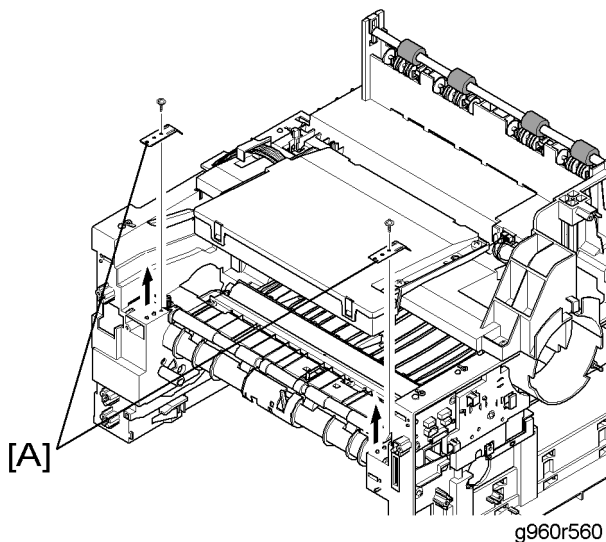

g960r560

2. Remove the spring plates [A] (⚙ x 1 each).

Paper Feed and Exit

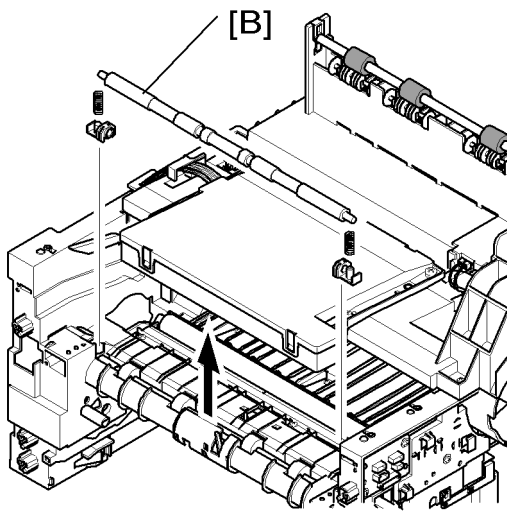

g960r561

3. Remove the registration idle roller [B] (bushing x 2, spring x 2).

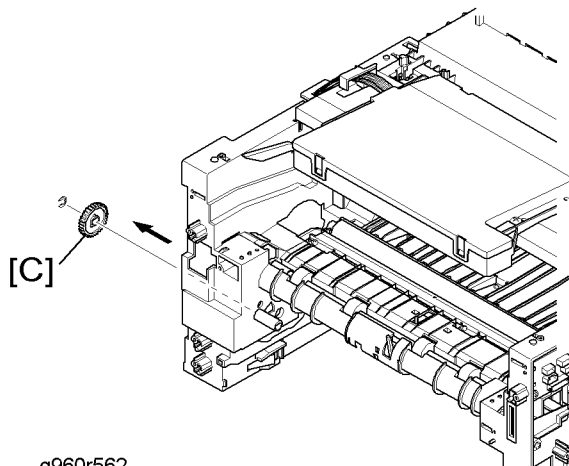

g960r562

4. Remove the feed roller gear [C] (⊗ x 1).

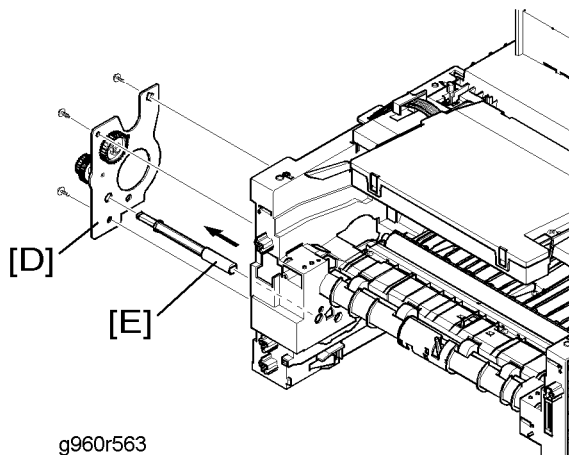

g960r563

5. Remove the feed gear bracket [D] (⚙ x 3).

- Remove the feed roller shaft [E]

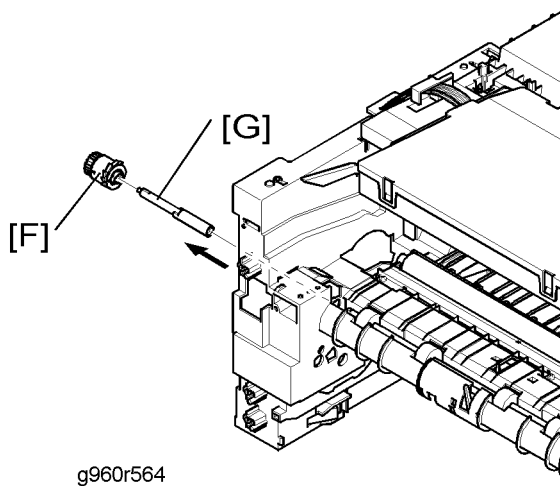

- Remove the registration clutch [F].
- Remove the registration roller shaft [G].

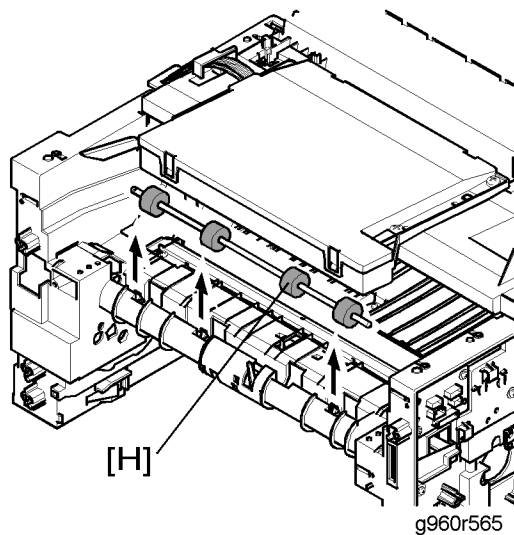

- Remove the registration roller [H].

Note

- Do not touch the rubber parts of the registration roller, as doing so could potentially cause a malfunction due to a foreign substance getting onto the surface.

3.6.9 FEED AND BY-PASS SOLENOIDS

- Before you remove the feed and by-pass solenoids, you should remove:
 - Duplex guide unit (➔Sec. 3.6.2 "Duplex Guide Unit")
 - Feed gear bracket (➔Sec. 3.6.8, Step 5 "Feed Gear Bracket")

Paper Feed and Exit

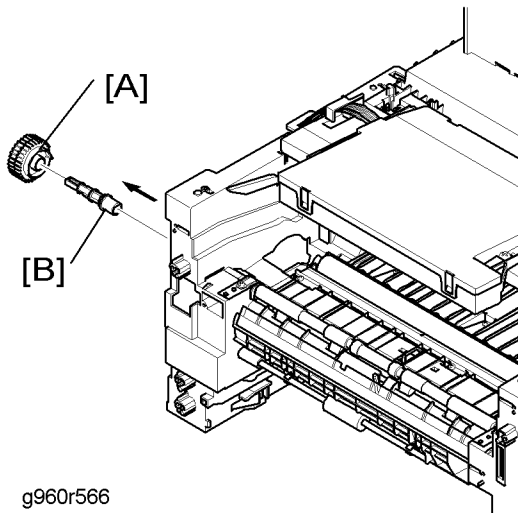

2. Remove the pick-up roller gear [A] and pick-up roller shaft [B].

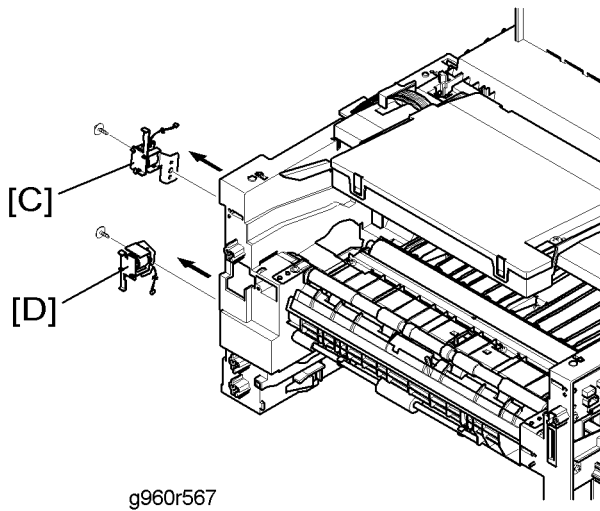

3. Remove the feed solenoid [C] (⚙ x 1, ⚙ x 1).
4. Remove the by-pass solenoid [D] (⚙ x 1, ⚙ x 1).

3.6.10 EXIT ROLLER

1. Before you remove the exit roller, you should remove:
 - Fuser unit (→Sec. 3.9.1 "Fuser Unit")
 - Middle cover (→Sec. 3.6.4 "Middle Cover")

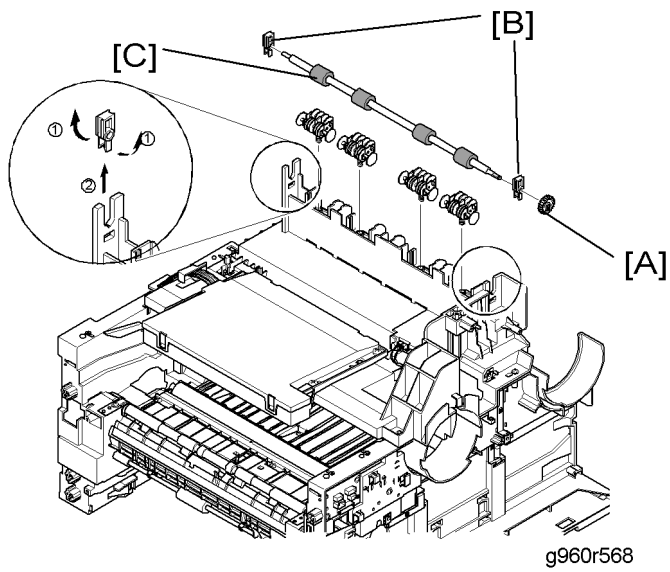

2. Remove the exit roller gear [A].
3. Remove the exit roller bearings [B]
4. Remove the exit roller [C].

3.7 LASER OPTICS

3.7.1 LSU

1. Before you remove the LSU, you should remove:
 - Middle cover (→Sec. 3.6.4 "Middle Cover")

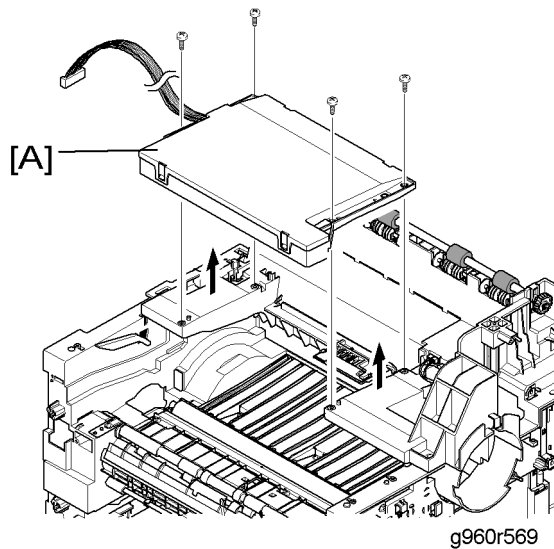

2. Remove the LSU [A] (⚙ x 4, 🛠 x 1).

3.8 IMAGE TRANSFER

3.8.1 TRANSFER ROLLER

1. Before you remove the transfer roller, you should remove:
 - Middle cover (→Sec. 3.6.4 "Middle Cover")
 - LSU (→Sec. 3.7.1 "LSU")

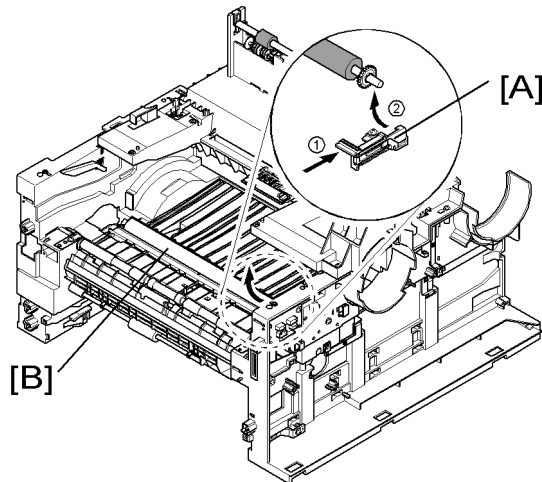

g960r570

2. Pull the transfer roller holder [A].
3. Remove the transfer roller [B].

Fusing

3.9 FUSING

3.9.1 FUSER UNIT

1. Before you remove the fuser unit, you should remove:
 - Rear cover (➔Sec. 3.2.4, Step 2 "Rear Cover")

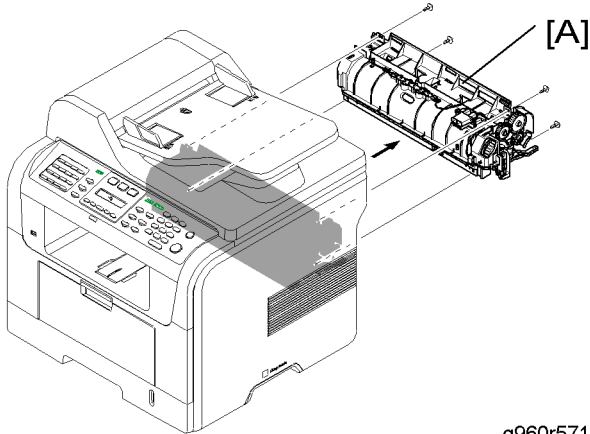

g960r571

2. Remove the fuser unit [A] (⚙ x 4)

3.9.2 THERMOSTAT

1. Before you remove the thermostat, you should remove:
 - Fuser unit (➔Sec. 3.9.1 "Fuser Unit")

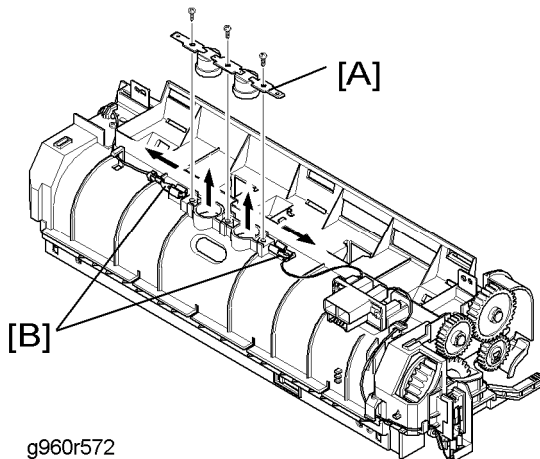

g960r572

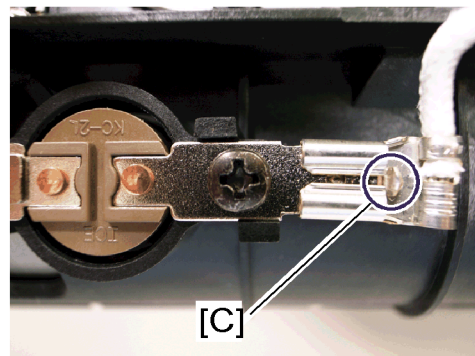

g960r575

2. Remove the thermostats [A] (⚙ x 3, ⚙ x 2).
 - When disconnecting wires connected to the terminal [B], press down on the lock-release tab [C] on the terminal connector and then disconnect it by sliding it off the terminal.

3.9.3 THERMISTOR

1. Before you remove the thermistor, you should remove:
 - Fuser unit (→Sec. 3.9.1 "Fuser Unit")

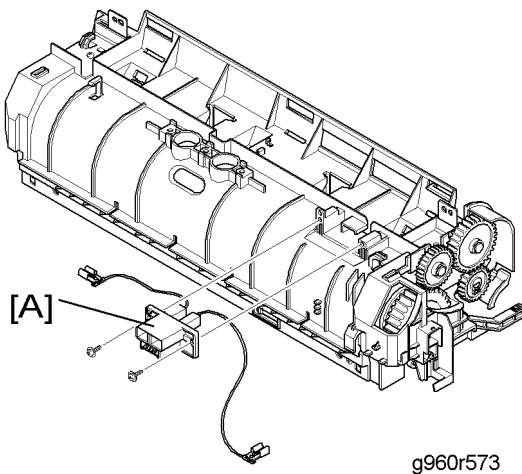

2. Remove the connector [A] (⚙ x 2, 🗑 x 3).
 - When disconnecting the terminal connectors, first press down on the lock-release tab (on the terminal connector), and then disconnect it by sliding it off.

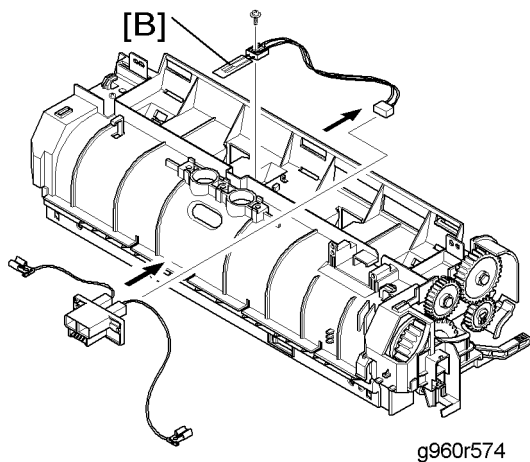

3. Remove the thermistor [B] (⚙ x 1).

3.9.4 HEAT ROLLER

1. Before you remove the heat roller, you should remove:
 - Fuser unit (→Sec. 3.9.1 "Fuser Unit")

Fusing

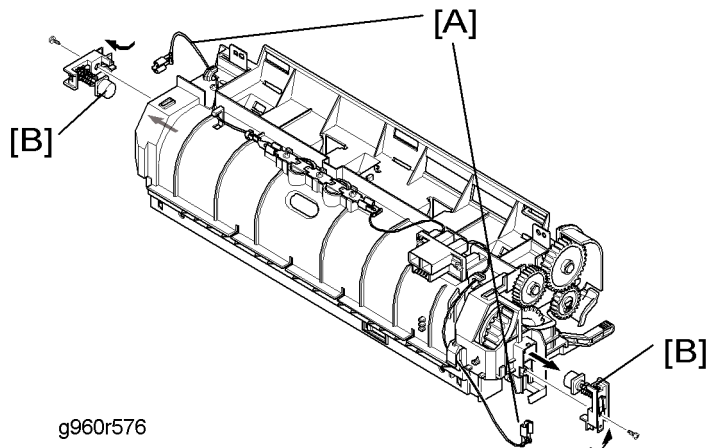

2. Disconnect the terminal connectors [A] (refer to "Thermostat" about disconnecting the terminal connectors).
 - In case you cannot access the tab on the terminal, first remove the terminal connection [B], and then press down on the tab while pulling the connector to disconnect the connector by sliding it off.

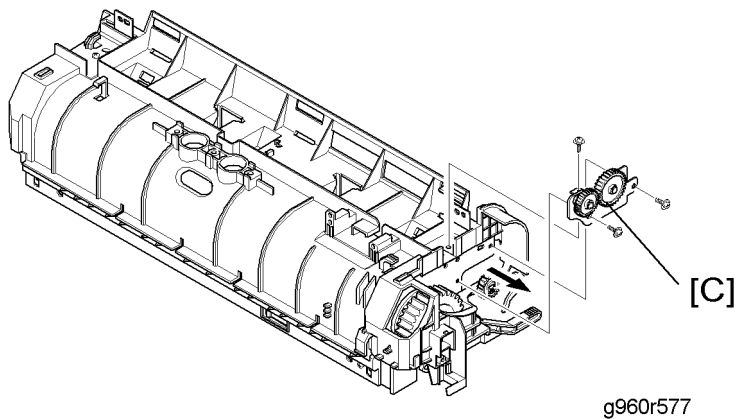

3. Remove the gear unit [C] (⌀ x 3).

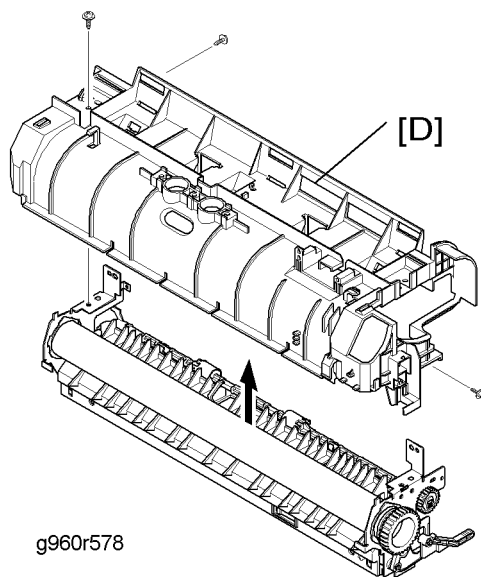

4. Remove the fuser cover [D] (⚙ x 3).

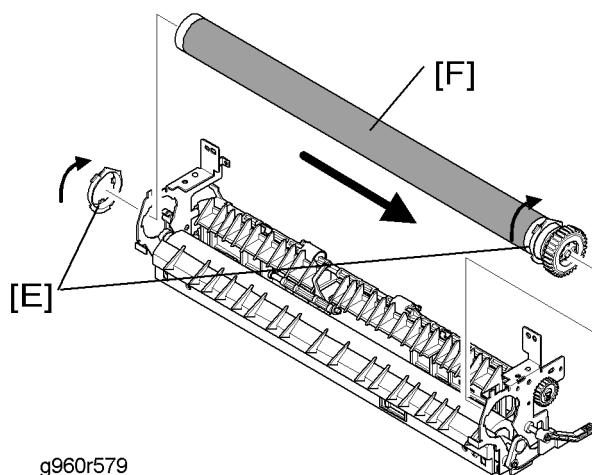

5. Rotate the bushings [E] in the direction of the arrow as shown above.
6. Slide the heat roller [F] in the direction of the arrow as shown above, and then remove it.

Note

- Be careful not to damage or dirty the surface of the heat roller while replacing it.

3.9.5 PRESSURE ROLLER

1. Before you remove the pressure roller, you should remove:
 - Fuser unit (→Sec. 3.9.1 "Fuser Unit")
 - Heat roller (→Sec. 3.9.4 "Heat Roller")

Fusing

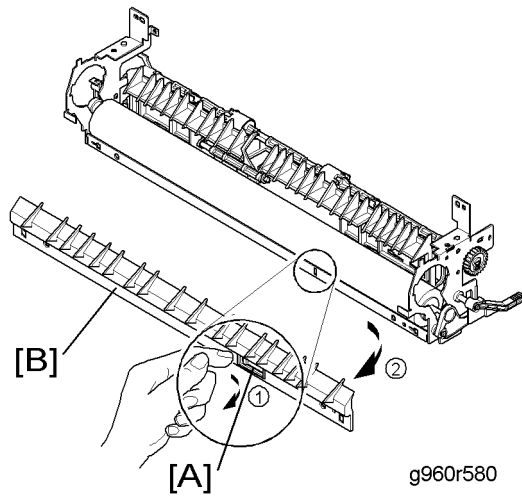

2. Release the hook [A], and then remove the feed-in guide [B].

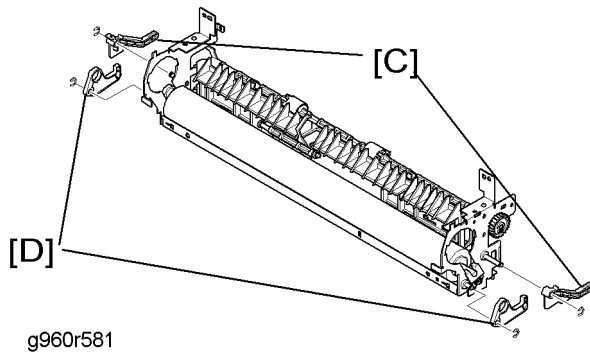

3. Remove the pressure levers [C] and pressure roller holders [D] (Ⓒ x 1 each).

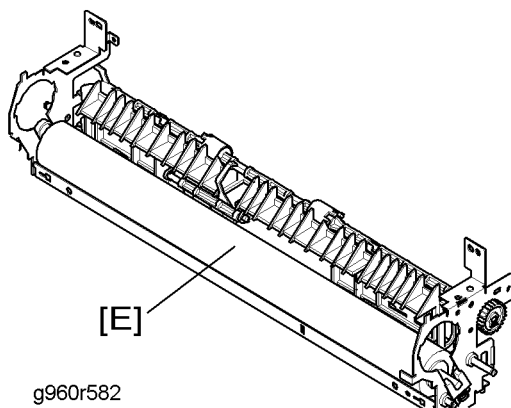

4. Remove the pressure roller [E].

3.10 DRIVE

3.10.1 MAIN MOTOR

1. Before you remove the main motor, you should remove:
 - Left side cover (➔Sec. 3.2.6 "Left Side Cover")
 - Controller bracket (➔Sec. 3.10.1 "Main Board")

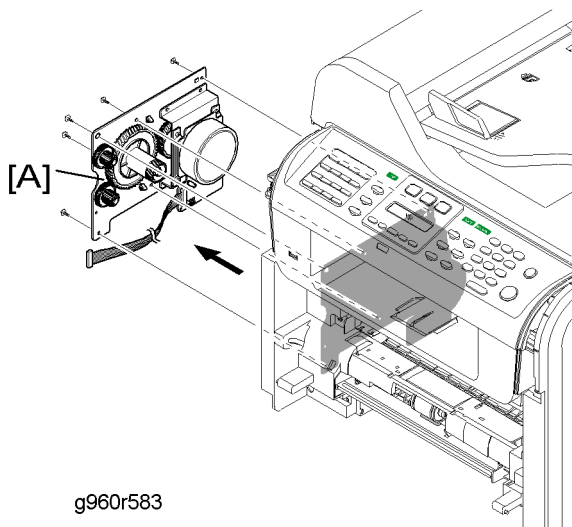

2. Remove the main drive unit [A] (⚙ x 5, ⚙ x 1).

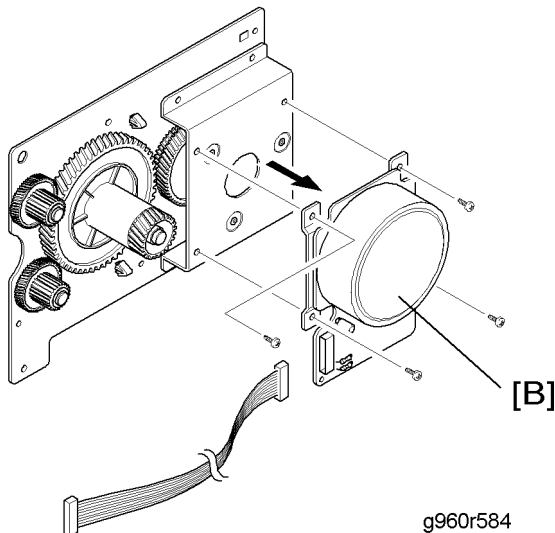

3. Remove the main motor [B] (⚙ x 4).

3.10.2 DUPLEX MOTOR

1. Before you remove the duplex motor, you should remove:

Drive

- Right side cover (➔Sec. 3.2.5 "Right Side Cover")

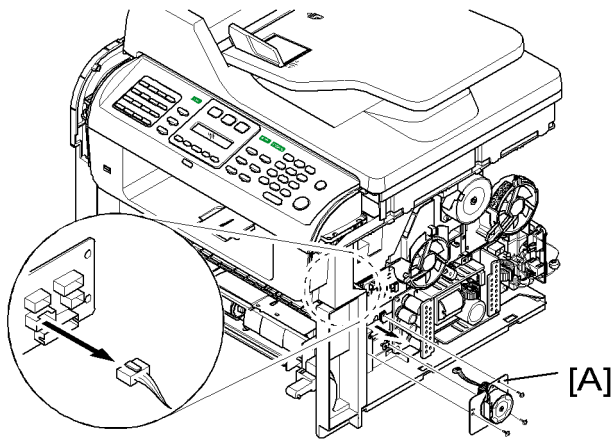

g960r585

2. Remove the duplex drive unit [A] (⚙️ x 3, 🛠️ x 1)

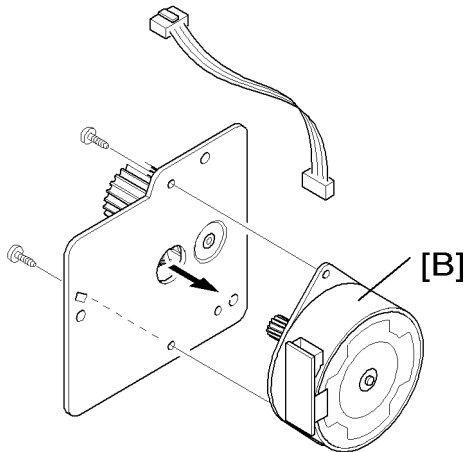

g960r586

3. Remove the duplex motor [B] (⚙️ x 2, 🛠️ x 1).

3.10.3 EXIT MOTOR

1. Before you remove the exit motor, you should remove:
 - Right side cover (➔Sec. 3.2.6 "Left Side Cover")

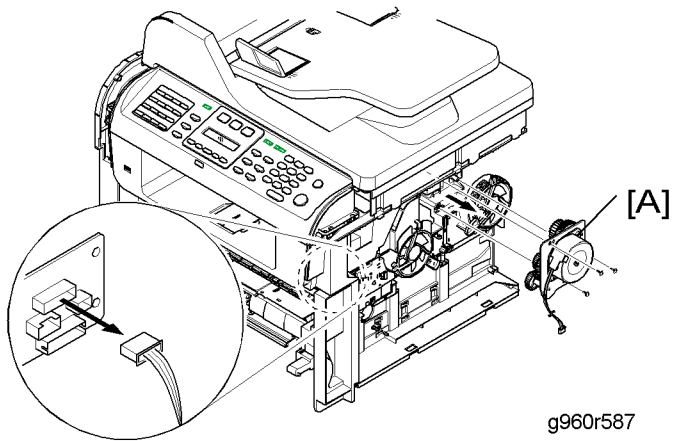

2. Remove the exit drive unit [A] (⚙️ x 3, 🛠️ x 1).

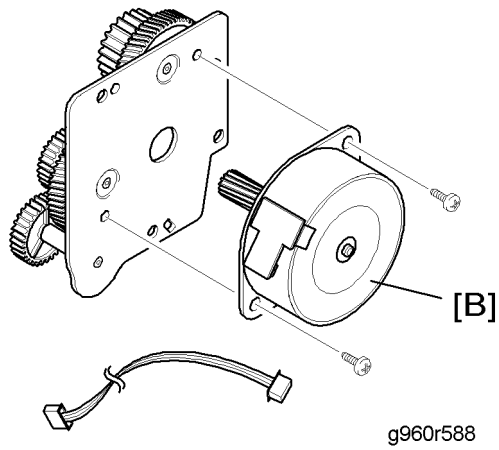

3. Remove the exit motor [B] (⚙️ x 2, 🛠️ x 1).

Others

3.11 OTHERS

3.11.1 DUPLEX AND MAIN FAN MOTORS

1. Before you remove the duplex or main fan motor, you should remove:
 - Right side cover (➔Sec. 3.2.5 "Right Side Cover")

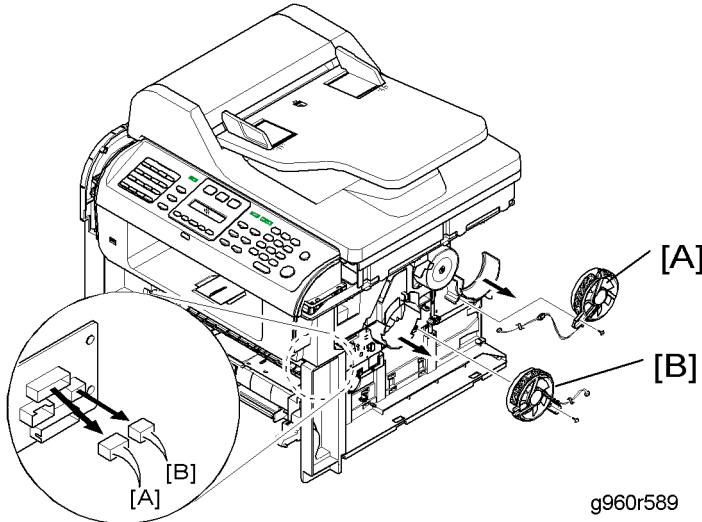

2. Remove the duplex fan motor [A] (⚙ x 2, 🛠 x 1).
3. Remove the main fan motor [B] (⚙ x 2, 🛠 x 1).

3.11.2 MAIN BOARD

1. Before you remove the main board, you should remove:
 - Left side cover (➔Sec. 3.2.6 "Left Side Cover ")

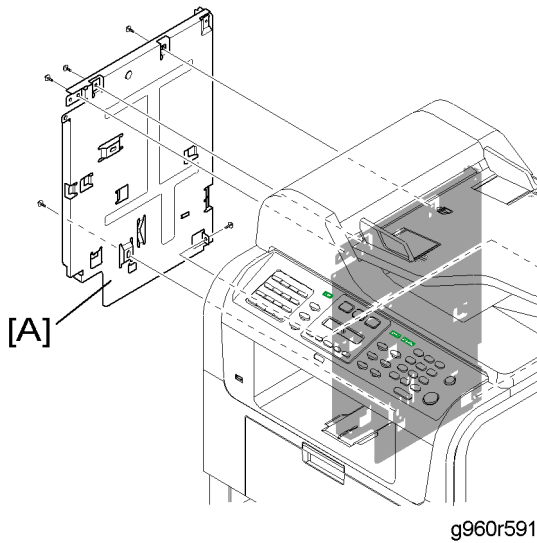

2. Remove the main board bracket [A] (⚙ x 5, all 🛠s)

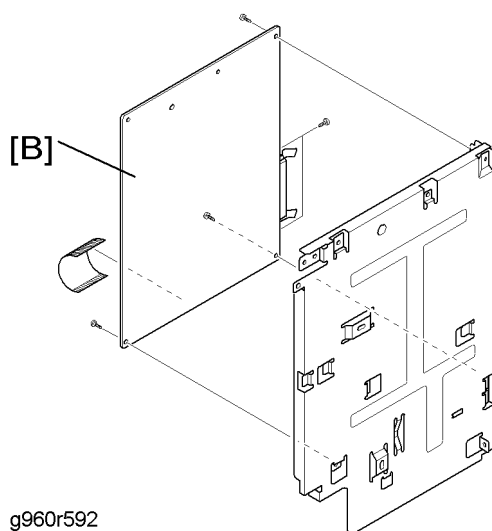

3. Remove the main board [B] (⚙ x 5, flat cable x 1).

Note

- Do "Memory Clear" after replacing the main board.

Connector Location

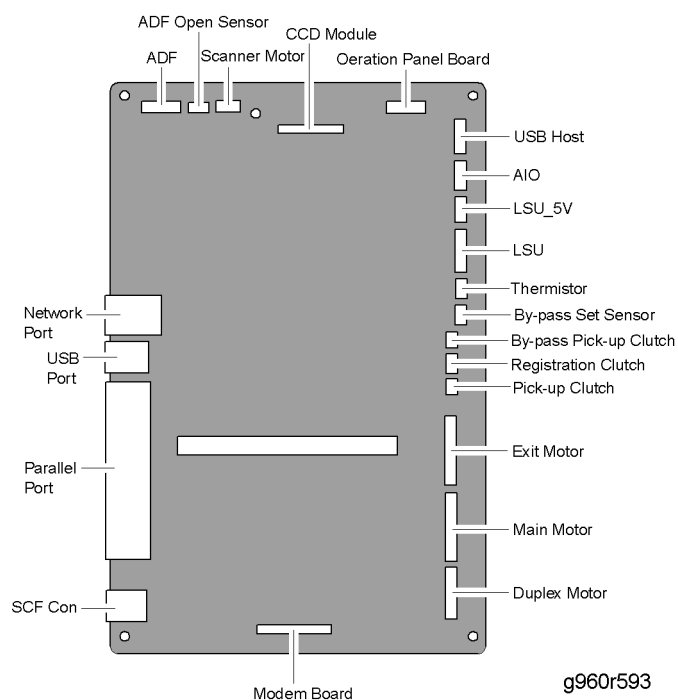

3.11.3 MODEM BOARD

1. Before you remove the modem board, you should remove:
 - Main board (➡Sec. 3.10.1 "Main Board")

Others

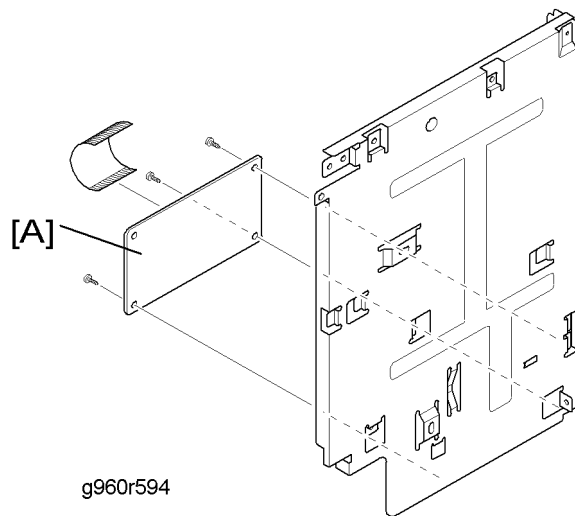

2. Remove the modem board [A] (⚙ x 3, flat cable x 1)

3.11.4 SPEAKER

1. Before you remove the speaker, you should remove
 - Main board (↪Sec. 3.10.1 "Main Board")

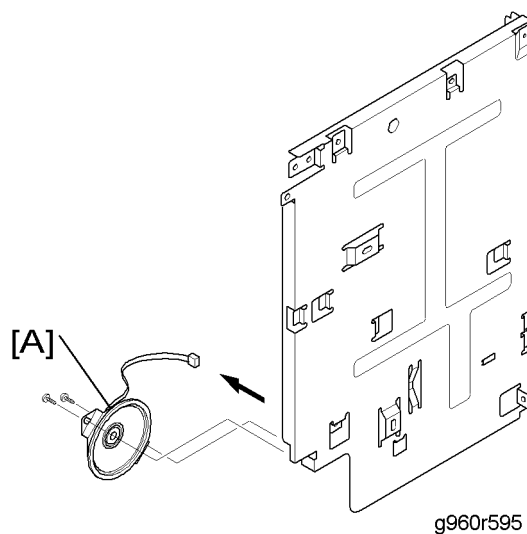

2. Remove the speaker [A] (⚙ x 2, 🗣 x 1)

3.11.5 USB HOST BOARD

1. Before you remove the USB host board, you should remove:
 - Left side cover (↪Sec. 3.2.6 "Left Side Cover")
 - Right side cover (↪Sec. 3.2.5 "Right Side Cover")
 - Scanner unit (↪Sec.3.5.1 "Scanner Unit")
 - Main board bracket (↪Sec. 3.10.1 "Main Board ")

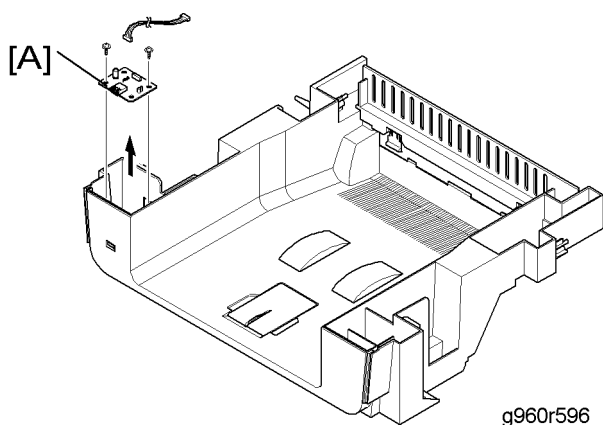

2. Remove the USB host board [A] (⚙ x 2, 📁 x 1).

3.11.6 CONNECTION BOARD

1. Before you remove the connection board, you should remove:
 - Right side cover (➡Sec. 3.2.5 "Right Side Cover")

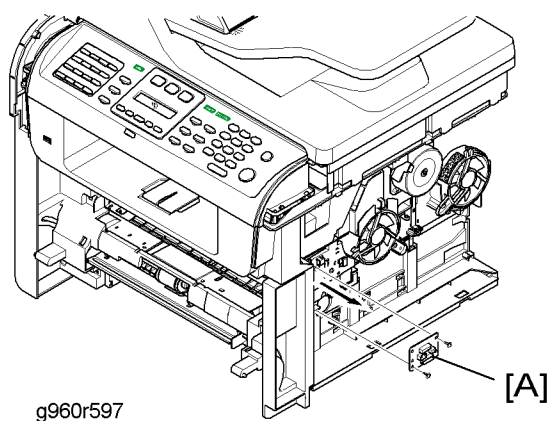

2. Remove the connection board [A] (⚙ x 2, all 📁s).

Connector Location

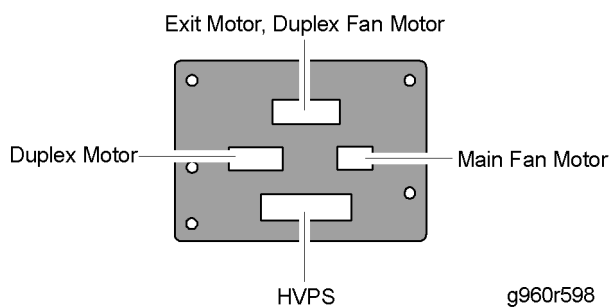

3.11.7 TERMINAL BOARD

1. Before you remove the terminal board, you should remove:
 - Middle cover (➡Sec. 3.6.4 "Middle Cover")

Others

- LSU (↖Sec. 3.7.1 "LSU")

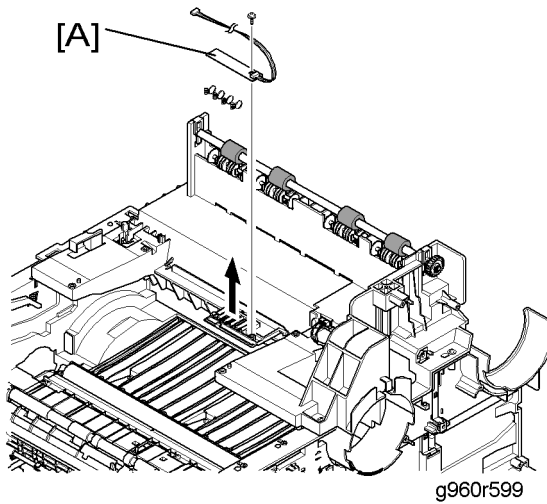

2. Remove the terminal board [A] (⚙ x 1, 🛠 x 1).

3.11.8 POWER SUPPLY BOARD

1. Before you remove the power supply board, you should remove:
 - Right side cover (↖Sec. 3.2.5 "Right Side Cover")
 - Duplex drive unit (↖Sec. 3.10.2 "Duplex Motor")

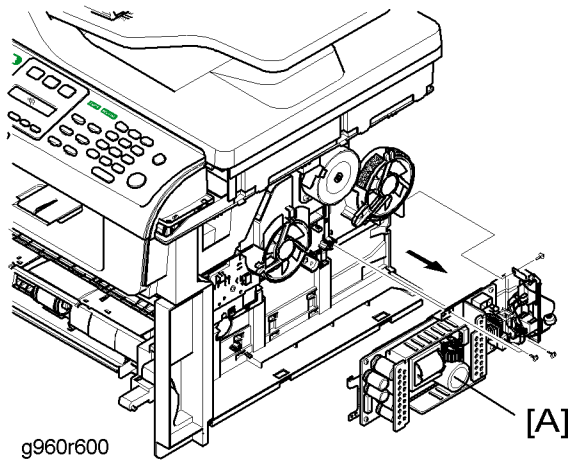

2. Remove the power supply unit [A] (⚙ x 3, 🛠 x 2).

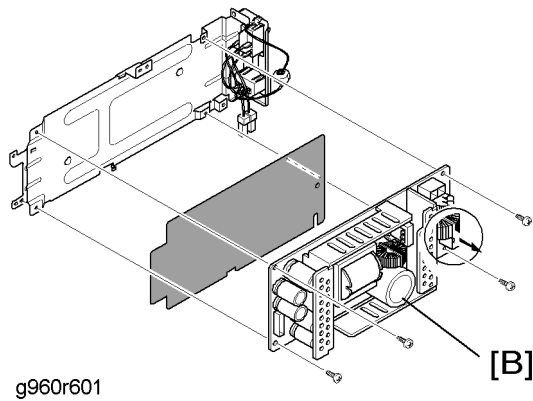

3. Remove the power supply board [B] (4).

3.11.9 HIGH VOLTAGE POWER SUPPLY BOARD

1. Before you remove the power supply board, you should remove:
 - Duplex drive unit (Sec. 3.10.2, Step 2 "Duplex Drive Unit")
 - Duplex guide unit (Sec. 3.6.2 "Duplex Guide Unit")

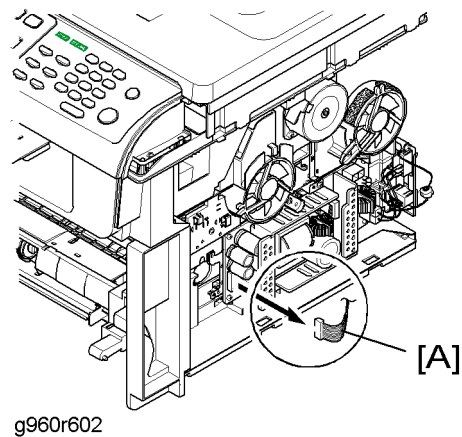

2. Disconnect HVPS connector [A].

Others

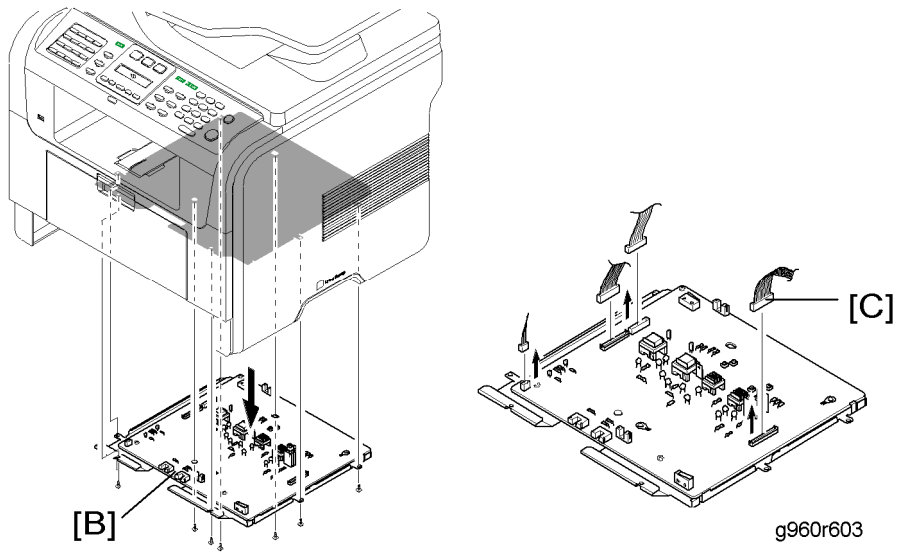

3. Remove the high voltage power supply unit [B] (⚙ x 8, All ⚙s)
 - Disconnect the connection board and power supply board harness [C] first, and then other harnesses.

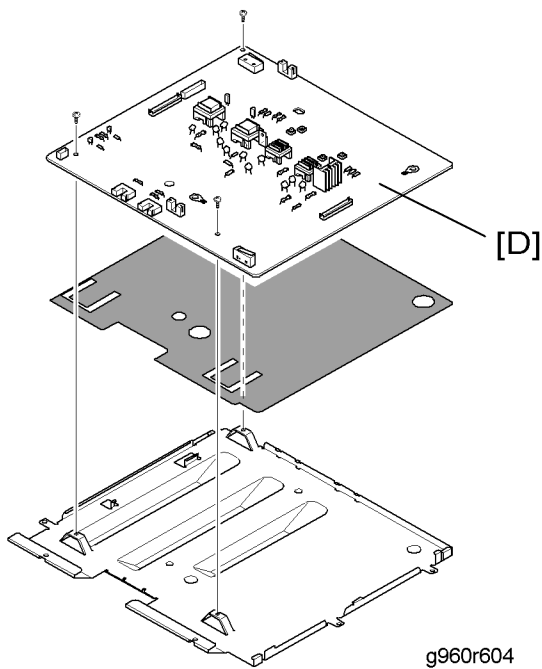

4. Remove the high voltage power supply board [D] (⚙ x 3).

TROUBLESHOOTING

4. TROUBLESHOOTING

4.1 PROCEDURE OF CHECKING SYMPTOMS

Before attempting to repair the printer, first obtain a detailed description from the customer of the problem.

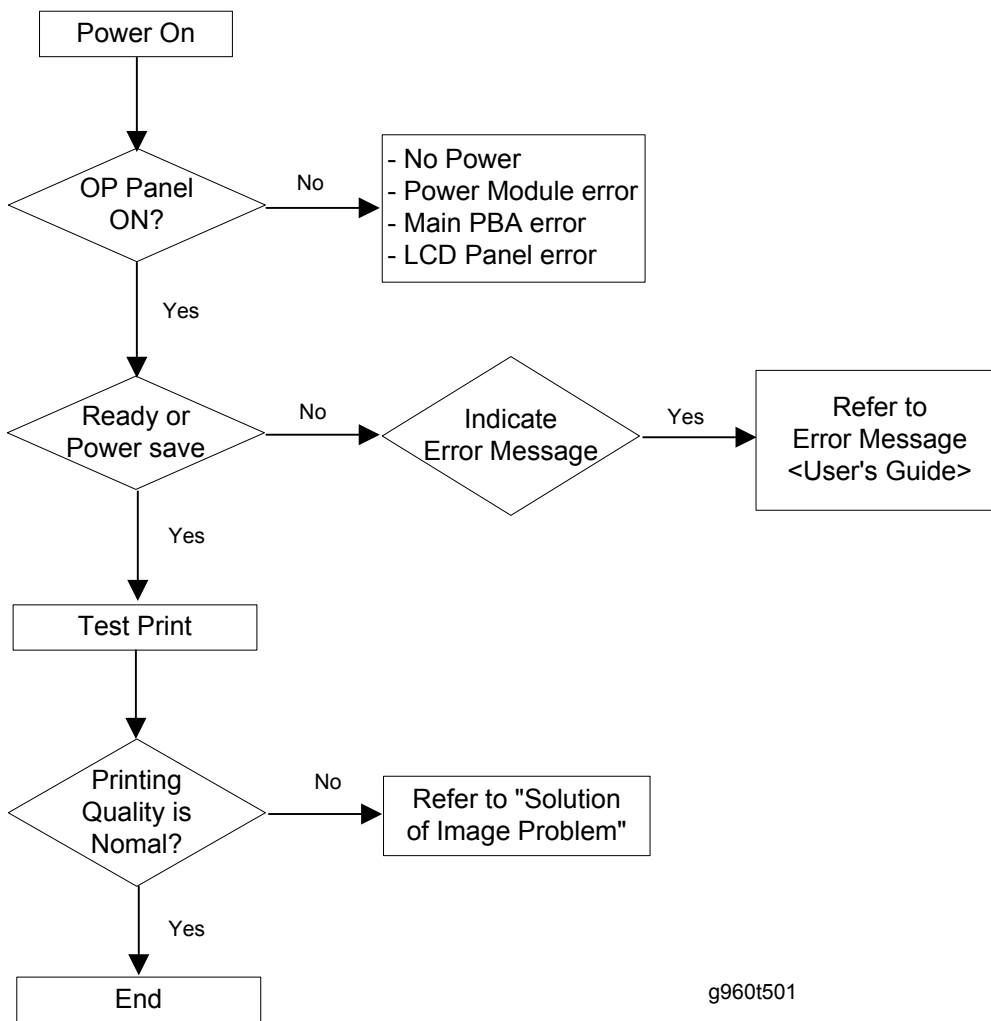

Trouble-shooting

Display Screen and Error Messages

4.2 DISPLAY SCREEN AND ERROR MESSAGES

4.2.1 DISPLAY SCREEN

Please refer to User's Guide for familiarization with the machine's display screen messages.

4.2.2 ERROR MESSAGES

Please refer to User's Guide for familiarization with the machine's display screen messages.

4.3 PAPER FEEDING PROBLEMS

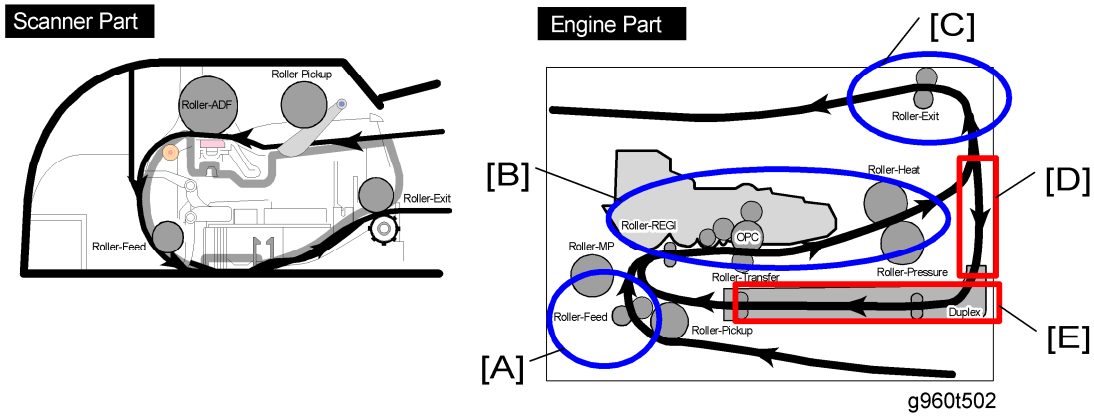

	Jam Location
[A]	Paper Jam 0: In the paper feed area (tray1, optional tray 2 or multi-purpose tray)
[B]	Paper Jam 1: In the fusing unit area or around the toner cartridge
[C]	Paper Jam 2: In the paper exit area
[D]	Duplex Jam 0: In the duplex unit
[E]	Duplex Jam 1: Between the duplex unit and rear cover area

Trouble-shooting

4.3.1 WRONG PRINT POSITION

Description: Printing begins at the wrong position on the paper.	
Problem and Cause	Solution
Wrong sensing time caused by defective feed sensor actuator.	Replace the defective feed sensor actuator.

Paper Feeding Problems

4.3.2 JAM 0

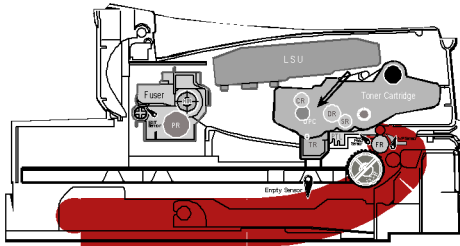

g960t536

<p>Description:</p> <ol style="list-style-type: none"> 1. Paper does not exit the cassette. 2. Jam-0 occurs if the paper feeds into the printer. 	
Problem and Cause	Solution
<ol style="list-style-type: none"> 1. Check the pick-up clutch by using "Engine Test Mode". 2. Check the surface of the pick-up roller for foreign matter. 3. If continuous clustering occurs, check whether the assembly slot between pick-up roller shaft and pick-up roller opens or is broken away. 4. If the paper feeds into the machine and Jam 0 occurs, perform "Engine Test Mode" to check the feed-sensor of the main board. 	<ol style="list-style-type: none"> 1. Replace the pick-up clutch. 2. Clean with soft cloth dampened with IPA (Isopropyl Alcohol) or water. 3. Replace the pick-up roller and/or pick-up roller shaft.

4.3.3 JAM 1

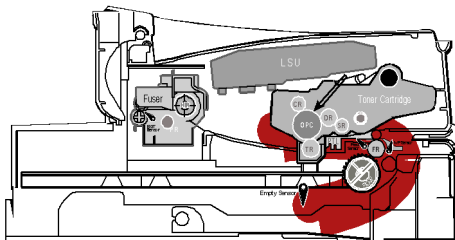

g960t537

<p>Description:</p> <ol style="list-style-type: none"> 1. Paper is jammed in front of or inside the fusing unit. 2. Paper is stuck in the discharge roller and in the fusing unit just after passing through the Actuator-Feed. 	
Problem and Cause	Solution
<ol style="list-style-type: none"> 1. If paper is jammed in front of or inside the fusing unit. 2. If the paper is stuck in the discharge roller and the fusing unit just after passing through the Actuator-Feed, Feed Actuator may be defective. 	<ol style="list-style-type: none"> 1. Replace the HVPS. 2. Reassemble the Actuator-Feed and Spring-Actuator if the movement is bad.

4.3.4 JAM 2

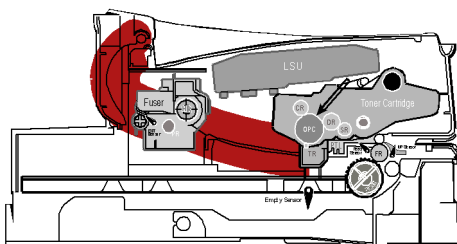

g960t538

<p>Description:</p> <ol style="list-style-type: none"> 1. Paper is jammed in front of or inside the fusing unit. 2. Paper is stuck in the discharge roller and in the fusing unit just after passing through the feed sensor. 	
Problem and Cause	Solution
<ol style="list-style-type: none"> 1. If the paper is completely fed out of the machine, but Jam 2 occurs, the exit sensor is defective. <ul style="list-style-type: none"> ▪ After the paper is completely discharged, the exit sensor 	<ol style="list-style-type: none"> 1. Check if the exit sensor actuator is defective. <ul style="list-style-type: none"> ▪ Check if the exit sensor actuator is deformed (Check if the lever part is deformed).

Trouble-shooting

Paper Feeding Problems

<p>actuator should return to the original position to shut the photo-sensor. Sometimes it takes longer than it should and does not return.</p> <p>2. If the paper is rolled in the Fusing Roller: This occurs when:</p> <ul style="list-style-type: none"> ▪ - a Guide claw is broken away or transformed. ▪ - the spring of a Guide claw is broken away or transformed. ▪ - the Heat-Roller or Pressure-Roller is seriously contaminated with toner. <p>3. Paper is accorded in the fusing unit.</p>	<ul style="list-style-type: none"> ▪ Check whether burrs occur in the assembly part of the exit sensor actuator or if the actuator is smoothly operated. ▪ Check if foreign matter or wire is caught in the actuator exit's operation. <p>2. If the paper is stuck in the fusing unit: disassemble the fusing unit and remove the jammed paper. Also clean the surface of the pressure roller with dry gauze.</p> <p>3. Remove the jammed paper after disassembling the fusing unit: Clean the surface of the pressure roller with dry gauze.</p> <ul style="list-style-type: none"> ▪ Remove the toner particles stained on the rib. ▪ Check the assemblage and performance of the exit.
--	---

4.3.5 DUPLEX JAM 1

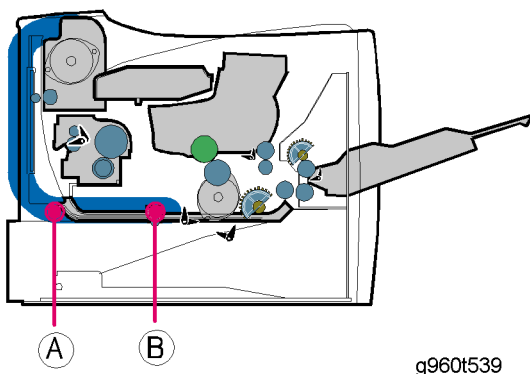

Description:

A message 'Duplex Jam 1' is displayed in an LCD window.

Problem and Cause	Solution
<ol style="list-style-type: none"> 1. When paper cannot trigger the duplex sensor. 2. When paper cannot reach the duplex sensor due to a paper jam in the duplex path. 3. The life of the duplex unit has expired. 	<ol style="list-style-type: none"> 1. Replace the HVPS or main board. 2. When a paper jam occurs on (A) after it is reversed: replace the 2nd exit roller after checking its operation. 3. When a paper jam occurs on (B) after it is reversed: replace the duplex roller after checking its operation. 4. Replace the duplex unit.

4.3.6 DUPLEX JAM 0

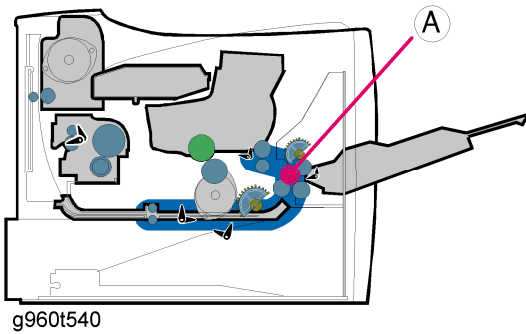

Trouble-shooting

<p>Description: A message 'Duplex Jam 0' is displayed in a LCD window.</p>	
Problem and Cause	Solution
<ol style="list-style-type: none"> 1. When paper cannot pass the duplex sensor. 2. When paper cannot reach to the registration sensor after it has passed the duplex sensor. 	<ol style="list-style-type: none"> 1. Replace a HVPS or main board. 2. When a leading edge of paper is jammed on (A), check the operation of a guide front. If it is worn or defective, replace it. 3. Check the operation of the feed roller and the registration roller. If they are worn or defective, replace them. 4. Replace the duplex unit.

4.3.7 MULTI-FEEDING

<p>Description: Multiple sheets of paper are fed at once.</p>	
Problem and Cause	Solution
<ol style="list-style-type: none"> 1. Solenoid malfunction (the solenoid does not work properly): Perform "Engine Test Mode". 2. Pad-Friction is contaminated with foreign matter. (oil, etc.) 3. The face of the paper is bent. 	<ol style="list-style-type: none"> 1. Replace the solenoid if necessary. 2. Clean the pad friction with soft cloth dampened with IPA (Isopropyl Alcohol). 3. Use smooth paper.

4.3.8 PAPER ROLLED IN THE FUSING UNIT

<p>Description: Paper rolled in the fusing unit</p>	
Problem and Cause	Solution
<ol style="list-style-type: none"> 1. Contamination of the pressure roller or heat roller (Background, Hot offset). 2. Check the claws of the fusing unit for deformities. 	<ol style="list-style-type: none"> 1. After disassembling the fusing unit, clean contamination between the heat roller and the thermistor and remove the contamination of the pressure roller. 2. If there is a heavy background, repair it with the background troubleshooting method. 3. Clean the surface of the heat roller with IPA or water. 4. Check the warp or separation of the print claw and the holder plate claw, and then manage it.

4.3.9 PAPER ROLLED ON THE OPC DRUM

Description: Paper is rolled up in the OPC.	
Problem and Cause	Solution
<ol style="list-style-type: none"> 1. Paper is too thin. 2. The paper is curled. 	<ol style="list-style-type: none"> 1. Use of normal paper is recommended. 2. How to remove rolled paper from the OPC. <ul style="list-style-type: none"> ▪ Remove the paper while turning the OPC against the ongoing direction. ▪ Clean fingerprints on the OPC gently with damp soft cloth.

4.3.10 DEFECTIVE ADF

Description: ADF does not work properly.	
Problem and Cause	Solution
<ol style="list-style-type: none"> 1. Check if ADF rubber and holder rubber are damaged. 2. Check if the document sensors of ADF Ass'y (3 paper sensors) are normal. 	<ol style="list-style-type: none"> 1. Replace the contaminated or damaged part. 2. If you cannot confirm the damaged part with the naked eye, try to replace the ADF unit.

4.4 PRINTING PROBLEMS (MALFUNCTIONS)

4.4.1 FUSING UNIT ERROR

<p>Description: A message “Low Heat Error Cycle Power/ Overheat Error Cycle Power” is displayed in the LCD panel.</p>	
Check for...	Solutions
<ol style="list-style-type: none"> 1. Check whether thermostat is open or not. 2. Check whether thermistor is open or not. 3. Operation is impossible due to a gear of a fuser being melted. 	<ol style="list-style-type: none"> 1. Replace the fusing unit if the thermostat is open. 2. Replace the fusing unit if a thermistor sensor is open. 3. Check whether the overheat mode circuit is operating normally or not. 4. Replace the fusing unit.

4.4.2 LSU (LASER SCANNING UNIT) ERROR

<p>Description: A message “LSU Motor Error Cycle Power/ LSU Hsync Error Cycle Power” is displayed in the LCD panel.</p>	
Check for...	Solutions
<ol style="list-style-type: none"> 1. Check whether the LSU (Laser Scanning Unit) connector is disconnected or not. 2. Check whether the LSU motor is rotating or not. 3. Check the HSYNC signal. 	<ol style="list-style-type: none"> 1. Connect the LSU harness properly. 2. Replace the LSU. 3. Replace the main board if the same error occurs again after replacing the LSU.

4.4.3 DEFECTIVE OPERATION (LCD WINDOW ★★★) DISPLAY

Description: Strange characters are displayed on the operation panel and buttons are not operational.	
Check for...	Solutions
<ol style="list-style-type: none"> 1. Clear the memory. 2. Check if the operation panel harness is connected to the operation panel board correctly. 	<ol style="list-style-type: none"> 1. Try again after clearing the memory. 2. After confirming that the operation panel harness is connected to the operation panel board correctly. If it is, then replace the operation panel board and main board in sequence.

4.4.4 DEFECTIVE LCD OPERATION

Description:	
Check for...	Solutions
<ol style="list-style-type: none"> 1. Clear the memory. 2. Confirm that there is a click sound when a key on the OPE panel is pressed. 	<ol style="list-style-type: none"> 1. The key is wrong itself or wrongly assembled. 2. After the key has been replaced, if it is still wrong, try to replace the operation panel board and the main board in sequence.

4.4.5 NONFUNCTIONING OF THE FUSING GEAR DUE TO MELTING

Description: The motor breaks away from its place due to gear melting.	
Check for...	Solutions

Trouble-shooting

Printing Problems (malfunctions)

Check the fusing unit.	<ol style="list-style-type: none">1. Replace the fusing unit.2. Replace the main board.3. Replace the power supply board.
------------------------	---

4.4.6 PAPER EMPTY

Description: The paper empty status on the operation panel is on even when paper is loaded in the cassette.	
Check for...	Solutions
<ol style="list-style-type: none">1. Bending or deformation of the paper empty sensor actuator.2. The function of the main board is defective. Perform "Engine Test Mode".	<ol style="list-style-type: none">1. Replace the defective actuator.2. Replace the main board.

4.4.7 PAPER EMPTY WITHOUT INDICATION

Description: The paper empty status on the operation panel does not come on when the paper cassette is empty.	
Check for...	Solutions
<ol style="list-style-type: none">1. Bending or deformation of the actuator of the paper empty sensor.2. The function of the main board is defective. Perform "Engine Test Mode".	<ol style="list-style-type: none">1. Replace the defective actuator.2. Replace the main board.

4.4.8 DOOR OPEN

Description: Door open status is on even when the front cover is closed.	
Check for...	Solutions
<ol style="list-style-type: none"> The front cover hook lever may be defective. Check the connector (CN1) and circuit of the cover switch section of the main board. 	<ol style="list-style-type: none"> Replace the hook lever, if defective. Check the insertion of the cover open switch connector. Replace the main board or cover open switch.

4.4.9 NO BEEP SOUND WHEN THE DOOR IS OPEN

Description: Door open status does not come on even when the front cover is open	
Check for...	Solutions
Check the connector (CN1) and circuit of the cover switch section of the main board.	<ol style="list-style-type: none"> Check the insertion of the cover open switch connector. Replace the main board or cover open switch.

4.4.10 DEFECTIVE MOTOR OPERATION

Description: Main motor is not driving when printing, and paper does not feed into the machine, resulting in 'Jam 0'.	
Check for...	Solutions
<ol style="list-style-type: none"> The motor harness or motor PCB may be defective. Perform the "Engine Test Mode" and check the motor operation. 	<ol style="list-style-type: none"> Check the motor harness, and then replace if defective. Replace the power supply board.

Trouble-shooting

4.4.11 NO POWER

Description: When system power is turned on, all lamps on the operation panel do not come on.	
Check for...	Solutions
<ol style="list-style-type: none">1. Check if the power input and SMPS output are normal.2. Check for functionality of the LED lights and LCD display on the front-cover if the operation panel does not show anything after warming-up.	<ol style="list-style-type: none">1. Replace the SMPS.2. Replace the control board.

4.4.12 CURVED VERTICAL LINE

Description: When printing, vertical lines become curved.	
Check for...	Solutions
If the supply of +24v is unstable in the main board linking with LSU, check drive with "Engine Test Mode":	<ol style="list-style-type: none">1. Replace LSU.2. Replace the main board.

4.5 PRINTING QUALITY PROBLEMS

4.5.1 VERTICAL BLACK LINE AND BAND



g186t534

<p>Description:</p> <ol style="list-style-type: none"> 1. Straight thin black vertical lines occur in the printing. 2. Dark black vertical band occurs in the printing. 	
Problem and Cause	Solution
<ol style="list-style-type: none"> 1. Deformed Doctor-blade or cleaning-blade, in print cartridge. 2. Scratched surface of the charge roller in the developer. 3. Partial depression or deformation on the surface of the transfer roller. 	<ol style="list-style-type: none"> 1. If causes one or two occur in the print cartridge, replace the developer and try to print. 2. Replace the transfer roller if cause three occurs.

Trouble-shooting

4.5.2 VERTICAL WHITE LINE



g186t535

Printing Quality Problems

Description: White vertical voids in the image.	
Problem and Cause	Solution
<ol style="list-style-type: none"> 1. Foreign matter stuck onto the window of internal lenses of LSU mirror. 2. Foreign matter or toner particles between the developer roller and blade. (In case that the life of the developer has expired, white lines or light image may occur in front of the image.) 3. It may occur when burr and foreign substances are on the window of the developer frame. 4. If the fusing unit is defective, blank areas occur periodically at the top of a black image. 	<ol style="list-style-type: none"> 1. Foreign matter stuck onto the window: Clean the LSU window with recommended cleaner (IPA) Clean the window with a clean cotton swab. 2. Foreign matter in the LSU: Open the LSU cover and clean the surface of the reflex mirror with a cotton swab. 3. No 3: Remove the foreign matter and burr of the exposure window. (Developer cartridge) 4. No. 4: Open the front cover and check ribs that correspond to the position of the blank areas. Remove if found. 5. If the problems are not solved, replace the print cartridge.

4.5.3 HORIZONTAL BLACK BAND

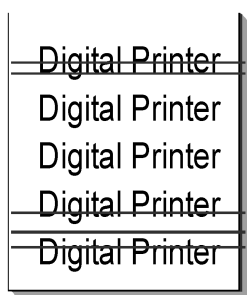

g186t521

Description: Dark or blurry horizontal stripes occur in the printing periodically (or continually).	
Problem and Cause	Solution

<ol style="list-style-type: none"> 1. Bad voltage terminals contacts to print cartridge. 2. The rollers of the print cartridge may be stained. Charge roller = 37.7 mm Supply roller = 53 mm Develop roller = 39 mm Transfer roller = 45.3 mm 	<ol style="list-style-type: none"> 1. Clean each voltage terminal of the Charge, Supply, Develop and Transfer roller. (Remove toner particles and paper particles.) 2. Clean the right gear that has a relatively small gap of the teeth in the OPC. 3. If the malfunction persists, replace the developer.
---	--

4.5.4 BLACK/WHITE SPOT

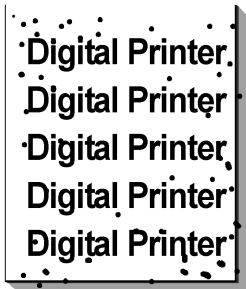

g186t522

Trouble-shooting

<p>Description:</p> <ol style="list-style-type: none"> 1. Dark or blurry black spots occur periodically in the printing. 2. White spots occur periodically in the printing. 	
Problem and Cause	Solution
<ol style="list-style-type: none"> 1. If dark or blurry black spots occur periodically, the rollers in the print cartridge may be contaminated with foreign matter or paper particles. (Charge roller: 37.7 mm interval OPC drum: 75.5 mm interval) 2. If faded areas or voids occur in a black image at intervals of 75.5 mm, or black spots occur elsewhere, the OPC drum 	<ol style="list-style-type: none"> 1. Run OPC cleaning Mode Print and run the Self-test two or three times. 2. In case of 75.5 mm interval unremovable in 1, remove foreign substances stuck on the OPC location equivalent to black spots and white spots with a dry duster. 3. The transfer roller guarantees 70,000 prints in a normal environment. If the

Printing Quality Problems

<p>surface is probably damaged.</p> <p>3. If a black image is partially broken, the transfer voltage is abnormal or the transfer roller's life has expired.</p>	<p>roller's life is expired, replace it.</p> <p>4. In case of 37.7 mm interval irremovable in 1, take measures as to replace the developer cartridge and try to print out.</p> <p>5. Clean the inside of the set of the paper particles and foreign matter in order to avoid this problem.</p>
---	--

4.5.5 LIGHT IMAGE



g186t523

<p>Description: The printed image is light, with no ghost.</p>	
Problem and Cause	Solution
<p>1. Develop roller is stained when the developer cartridge toner is almost consumed.</p> <p>2. Ambient temperature is below 10°C.</p> <p>3. Bad contact caused by toner stains on the high voltage terminal of the HVPS.</p> <p>4. Abnormal output from HVPS. (Run self-test and check 1 to 4)</p>	<p>1. Check if the Toner Save mode is off.</p> <p>2. No 1: Replace the developer cartridge and try to print out.</p> <p>3. No 2: Wait 30 minutes after the machine is powered on before you start printing.</p> <p>4. No 3: Clean up the contaminated area by the toner.</p> <p>5. Replace the HVPS if the problems are not solved by the above four instructions.</p>

4.5.6 DARK IMAGE OR BLACK PAGE

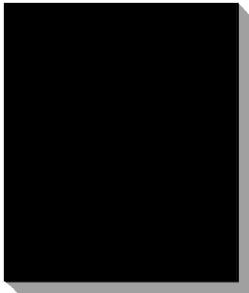

g186t524

<p>Description: The printed image is dark or black page.</p>	
Problem and Cause	Solution
<ol style="list-style-type: none"> 1. No charge voltage in the main board. 2. Charge voltage is not turned on due to bad contacts between the power supply on the side of the print cartridge and charge terminal of HVPS. 	<ol style="list-style-type: none"> 1. Clean the high voltage charge terminal. 2. Check the state of the connector which connects the main board and HVPS. 3. If steps 1 and 2 above do not correct the problem, replace the HVPS.

Trouble-shooting

4.5.7 UNEVEN DENSITY



g186t525

Printing Quality Problems

Description: Print density is uneven between left and right.	
Problem and Cause	Solution
<ol style="list-style-type: none"> 1. The pressure force on the left and right springs of the transfer roller is not even; the springs are damaged; the transfer roller is improperly installed; or the transfer roller bushing or holder is damaged. 2. The life of the developer has expired. 3. The toner level is not even on the developer roller due to a bad blade. 	<ol style="list-style-type: none"> 1. Replace both the left and right spring holder. 2. Gently shake the print cartridge. 3. Problem with the toner cartridge, replace the toner cartridge and try to print out.

4.5.8 BACKGROUND



g186t526

Description: Light dark background appears across entire printed page.	
Problem and Cause	Solution
<ol style="list-style-type: none"> 1. Recycled paper has been used. 2. The life of the developer has expired. 3. The up-to-down movement of the transfer roller is swift. 4. The HVPS is normal. 	<ol style="list-style-type: none"> 1. Quality is not guaranteed when using recycled paper. 2. Replace the toner cartridge. 3. Clean the bushing on the transfer roller. 4. Replace the HVPS.

4.5.9 GHOST (1)

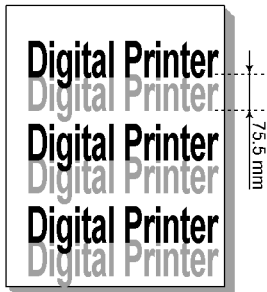

g960t527

<p>Description: Ghost image occurs at 75.5 mm intervals of the OPC drum across entire printed page.</p>	
Problem and Cause	Solution
<ol style="list-style-type: none"> 1. Bad contacts caused by contamination from toner particles between the high voltage terminal in the main body and the electrode of the developer. 2. Bad contacts caused by contamination from toner particles between high voltage terminal on the main body and the HVPS board. 3. The life of developer has expired. 4. Transfer roller lifetime (70,000 sheets) has been exceeded. 5. Abnormally low temperature (below 10°C). 6. Damaged cleaning blade in the developer. 	<ol style="list-style-type: none"> 1. Clean the contaminated terminals. 2. Problem in the toner cartridge, replace the toner cartridge and try to print. 3. Replace the main board if not solved by steps 1 and 2 above. 4. If not solved by step 3, check the transfer roller lifetime and replace it. 5. Wait about one hour after power on when using the machine. 6. Problem in the toner cartridge, replace the toner cartridge and try to print.

Trouble-shooting

4.5.10 GHOST (2)

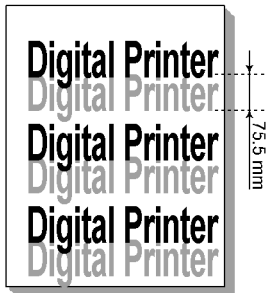

g960t527

<p>Description: Ghost image occurs at 75.5 mm intervals of the OPC drum on all pages of print jobs. (When printing on card stock or transparencies using manual feeder)</p>	
Problem and Cause	Solution
When printing on card stock thicker than normal paper or transparencies such as OHP, higher transfer voltage is required.	Select "Thick Mode" on paper type menu from the software application setting. After using, it is recommended that the mode should be returned to the original setting.

4.5.11 GHOST (3)

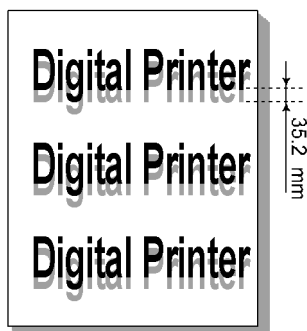

g960t528

<p>Description: Ghost occurs at 35.2 mm intervals.</p>	
Problem and Cause	Solution

<ol style="list-style-type: none"> 1. Life of the developer may be expired. 2. Abnormal voltage and bad contact of the terminal of the developing roller. 	<ol style="list-style-type: none"> 1. Problem in the toner cartridge, replace the toner cartridge and try to print out. 2. Check the approved voltage of the supply roller and terminal contact and adjust if necessary.
---	--

4.5.12 GHOST (4)

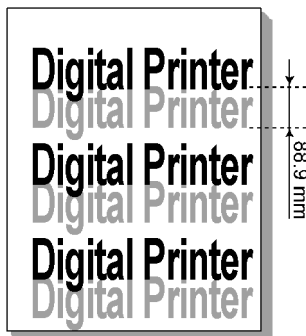

g960t528a

<p>Description: Ghost image occurs at 88.9 mm intervals.</p>	
<p>Problem and Cause</p>	<p>Solution</p>
<p>The temperature of the fusing unit is maintained at a high temperature.</p>	<p>Disassemble the fuser and remove the contaminated toner particles on the roller and clean out any foreign matter between the thermistor and heat roller. (Caution: can be deformed)</p>

4.5.13 STAINS ON THE FACE OF PAGE



g186t529

<p>Description: The background on the face of the printed page is stained.</p>	
Problem and Cause	Solution
<ol style="list-style-type: none"> 1. Toner leakage due to improperly sealed developer. 2. If the transfer roller is contaminated, stains on the face of a page may occur. 	<ol style="list-style-type: none"> 1. Replace the toner cartridge. 2. If the transfer roller is contaminated, run OPC Cleaning Mode Print two or three times. And perform Self-Test two or three times to remove contamination.

4.5.14 STAINS ON THE BACK OF PAGE

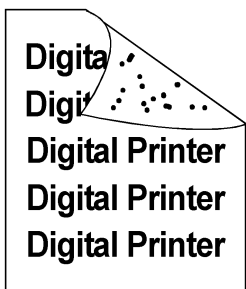

g186t530

<p>Description: The back of the page is stained.</p>

Problem and Cause	Solution
<ol style="list-style-type: none"> 1. Transfer roller is contaminated. 2. Pressure roller is contaminated. 	<ol style="list-style-type: none"> 1. Perform the OPC Cleaning Mode Print two or three times. Run self-test to remove the contamination of the transfer roller. 2. Replace the transfer roller if contaminated severely. 3. Disassemble the fusing unit and clean the H/R (Heat Roller) and P/R (Pressure Roller). And check the area between H/R and thermistor. If contaminated, clean the area, taking caution not to cause deformation of roller.

Trouble-shooting

4.5.15 BLANK PAGE PRINT OUT (1)

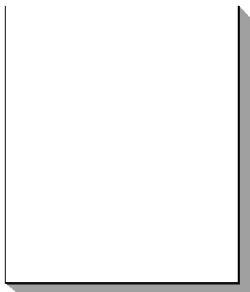

g186t531

<p>Description: Blank page is printed.</p>	
Problem and Cause	Solution
<p>Bad ground contacts in OPC and/or developer.</p>	<p>Remove contamination from the terminals of the toner cartridge and the machine.</p>

4.5.16 BLANK PAGE PRINT OUT (2)

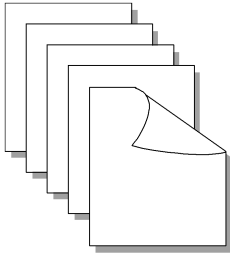

g186t532

Description: <ol style="list-style-type: none">1. Blank page is printed.2. One or several blank pages are printed.3. When the machine turns on, several blank pages print.	
Problem and Cause	Solution
<ol style="list-style-type: none">1. Bad ground contacts in OPC and/or developer.2. Abnormal solenoid.	<ol style="list-style-type: none">1. Remove contamination of the terminals of the toner cartridge.2. Perform the engine self test using "Engine Test Mode: code 0" to check if the Solenoid is normal.3. If not solved by steps 1 and 2 above, replace the main board.4. Turn the power off, delete print data from PC and try printing again.

4.6 FAX AND PHONE PROBLEMS

4.6.1 NO DIAL TONE

<p>Description: When on-hook button is pressed, there is no dial tone.</p>	
Problem and Cause	Solution
<ol style="list-style-type: none"> 1. Check if the telephone line cord is connected to "TEL LINE" correctly. 2. Check if it makes a "click" sound when the "On Hook Dial" key is pressed. 3. Check the connection of the harness between the LIU board and the main board. 4. Check if the speaker is connected correctly. 	<ol style="list-style-type: none"> 1. If the telephone cord is normal but there is no dial tone, then replace the LIU board. 2. If you cannot hear the click sound of the "On Hook Dial" key, the operation panel unit may be defective. Replace the operation panel unit. 3. Check the speaker connection, and try to replace it. 4. Lastly, replace the main board.

Trouble-shooting

4.6.2 DEFECTIVE MF DIAL

<p>Description: The MF DIAL is not functioning.</p>	
Problem and Cause	Solution
<ol style="list-style-type: none"> 1. Check if the telephone line is connected correctly. 2. When the BUTTON KEY is pressed, check if there is a 'click' sound. 3. Check the connection of HARNESS between the LIU and the Main PBA. 	<ol style="list-style-type: none"> 1. If there is no OHD "click" sound, the operation panel unit may be defective. Try to replace the operation panel unit. 2. If there is a "click" sound, after checking the connection of the HARNESS between the LIU and the main board, try to replace the harness. 3. If the problem still persists, then

Fax and Phone Problems

	<p>replace the LIU and the main board in sequence.</p> <p>Notes: Product supports the MF DIAL type only.</p>
--	--

4.6.3 DEFECTIVE FAX FORWARD/RECEIVE

<p>Description: The FAX FORWARD/RECEIVE is not functioning.</p>	
Problem and Cause	Solution
<ol style="list-style-type: none"> 1. Check if a dial tone can be heard by pressing OHD. 2. Check if a RECEIVE tone can be heard while MODEM testing in the TECH Mode. 	<ol style="list-style-type: none"> 1. If the MODEM testing is normal and there is no dial tone, then try to replace the LIU board. 2. If the MODEM testing is abnormal, try to replace the main board.

4.6.4 DEFECTIVE FAX FORWARD

<p>Description: RECEIVE is functioning, but FORWARD is not functioning or the received data is broken.</p>	
Problem and Cause	Solution
<ol style="list-style-type: none"> 1. Check if there is NOISE when pressing on-hook dial. 2. Check the RECEIVE condition by trying to forward a FAX to another fax machine from the forwarding side FAX. 3. Check if the telephone line connected to the Product is contaminated or gets stripped off or down. 	<p>If it makes NOISE while using on-hook dial, replace or repair the telephone line.</p>

4.6.5 DEFECTIVE FAX RECEIVE (1)

Description: FORWARD is functioning, but RECEIVE is not functioning or the received data are broken.	
Problem and Cause	Solution
<ol style="list-style-type: none"> 1. Check if there is NOISE when pressing on-hook dial. 2. Check the RECEIVE condition by trying to receive a FAX at another fax machine. 	<p>If it makes NOISE while on-hooking, replace or repair the telephone line.</p>

4.6.6 DEFECTIVE FAX RECEIVE (2)

Description: The received data is lengthened or cut in the printing.	
Problem and Cause	Solution
<ol style="list-style-type: none"> 1. Check if there is NOISE when pressing on-hook dial. 2. Ask to the forwarding side, check the image quality of another machine receiving a FAX. 	<ol style="list-style-type: none"> 1. If it makes NOISE, rearrange the telephone line. (Refer to 'Defective FAX RECEIVE'.) 2. Check if the FAX status of the forwarding side is also normal.

4.6.7 DEFECTIVE FAX RECEIVE (3)

Description: The phone is ringing continuously, but it cannot receive.	
Problem and Cause	Solution
Check if the RECEIVE Mode is TEL MODE	Even when the RECEIVE Mode is changed

Fax and Phone Problems

or FAX MODE.	to FAX MODE, it cannot receive, then replace the LIU and the main board in sequence.
--------------	--

4.6.8 DEFECTIVE FAX RECEIVE (4)

Description: The received data is reduced by more than 50% in the printing.	
Problem and Cause	Solution
Check the FAX status of the forwarding side.	After checking the data of the forwarding side, correct the FAX of the forwarding side.

4.6.9 DEFECTIVE AUTOMATIC RECEIVING

Description: The automatic receiving function is not working.	
Problem and Cause	Solution
Check if the RECEIVE Mode is TEL MODE or FAX MODE.	<ol style="list-style-type: none"> 1. If the RECEIVE Mode is set to the TEL MODE, reset it to the FAX MODE. 2. Even after the RECEIVE Mode is changed to the FAX Mode, if it cannot receive, then try to replace the LIU and the main board in sequence.

4.7 COPY PROBLEMS

4.7.1 WHITE COPY

Description: Blank page is printed out when copying.	
Problem and Cause	Solution
<ol style="list-style-type: none"> 1. See if the Scan-Cover is open. 2. Check the shading profile. 3. Check white/black reference voltage on the main board. 	<ol style="list-style-type: none"> 1. Room light can transit a thin original. 2. Remake shading profile in the tech mode. 3. Replace U60 if it is defective. <ul style="list-style-type: none"> ▪ U60-154 = 0.5V ▪ U60-155 = 3.3V

4.7.2 BLACK COPY

Description: Black page is printed out when copying.	
Problem and Cause	Solution
<ol style="list-style-type: none"> 1. Check the CCD problem on the main board. 2. Check shading profile. 	<ol style="list-style-type: none"> 1. Check the CCD harness contact. 2. Remake shading profile in tech mode.

4.7.3 ABNORMAL NOISE

Description: There is noise when copying.	
Problem and Cause	Solution

Copy Problems

<ol style="list-style-type: none">1. Check the Scanner Motor for any mechanical disturbance.2. Check the Motor Driver in Driver PBA.	<ol style="list-style-type: none">1. Check the right position of the Scanner Motor, and check for any mechanical disturbance in the CCD carriage part.2. If any driver is defective, replace it.
---	---

4.7.4 DEFECTIVE IMAGE QUALITY

Description: The copied image is light or bad.	
Problem and Cause	Solution
<ol style="list-style-type: none">1. Check shading profile.2. Check the gap between original and scanner glass.3. Check printing quality.	<ol style="list-style-type: none">1. Remake shading profile in tech mode.2. A gap above 0.5 mm can cause a blurred image.3. See "Print" troubleshooting.

4.8 SCANNING PROBLEMS

4.8.1 DEFECTIVE PC SCAN

Description: The PC Scan is not functioning at all.	
Problem and Cause	Solution
<ol style="list-style-type: none"> 1. Check the Cable (USB or Parallel). 2. Check if the driver is installed properly. 3. Check if copy function operates normally. 	<ol style="list-style-type: none"> 1. If the cable connection to the PC is not connected properly, reconnect it. 2. After confirming that it is proper by performing a PC printing test related to driver setup, if it is not so, reinstall it. (Refer to User's Manual.) 3. If copy function works, replace the main board. If copy function doesn't work, replace the CCD module and try again.

4.8.2 DEFECTIVE IMAGE QUALITY OF PC SCAN

Description: The image PC scanned is not clear or bad.	
Problem and Cause	Solution
<ol style="list-style-type: none"> 1. Check the waveform form by performing a CCD test in TECH Mode. 2. Check if the resolution is set too low in PC Scan options. (Refer to User's Manual.) 	<ol style="list-style-type: none"> 1. If the CCD waveform is abnormal, try replacing the CCD module. 2. If the resolution is set too low, familiarize the user with this setting.

4.9 NETWORK PROBLEMS

4.9.1 GENERAL PROBLEMS

Problem	Solution
System does not function with some wrong values entered by mistake while configuring.	Possibly the parameters in PortThru are corrupted. Restart the system and set to factory defaults via the printer front panel or via your computer using SyncThru.
Not able to access from SNMP Manager. SyncThru is unable to automatically detect print servers.	Try pinging from the same system on which SNMP manager is running. If this does not succeed, there is likely a problem with network connectivity between the manager and PortThru. If ping succeeds, verify that community names with sufficient permissions have been used.
SyncThru is unable to automatically detect print servers.	Check the environment as described in Auto Detection of Print Server. Check NetWare file server consoles for error messages regarding nodes with conflicting network numbers.
When attempting to set the IP address to the print server, DHCP, BOOTP, or RARP cannot be seen.	On Network Interface in SyncThru, you should set "Static" to "IP Address Assignment Method" in the TCP/IP tab. You should set the IP address, Subnet Mask and Default Gateway to print server.
Print server does not print using TCP/IP protocol.	<ol style="list-style-type: none"> 1. Check whether TCP/IP protocol is installed in your PC. 2. Check whether your PC is on the same network with print server.
Unable to print in NetWare environment.	Use SyncThru to see if PortThru indicates that queue is serviceable. If not, the login permissions may have changed or the configuration information for queues, printers and print servers may have

Problem	Solution
	<p>been changed. Verify using PCONSOLE and NWADMIN that the configuration is correct and check the job queue to see if the print job exists. Check that NetWare is enabled on PortThru. Check that Check Job is configured on PortThru.</p>
<p>The status of printer is displayed 'unknown' in SyncThru.</p>	<ol style="list-style-type: none"> 1. Check the protocol of your PC and install DLC/LLC or IPX/SPX protocol. 2. Assign IP Address to PortThru using the front panel.
<p>The name of printer is displayed empty while adding a port and the printer doesn't function.</p>	<p>Check the protocol of your PC and install DLC/LLC or IPX/SPX protocol. Assign IP Address to PortThru using the front panel.</p>

Trouble-shooting

4.9.2 MACINTOSH PROBLEMS

Problem	Solution
<p>The printer name is not displayed in the Chooser.</p>	<ol style="list-style-type: none"> 1. Make sure the printer is connected to network correctly. 2. Make sure the printer is configured in SyncThru using the new name. 3. After turning on the printer, wait three minutes, then check it again. 4. Make sure that your Macintosh is connected to the network through Ethernet. 5. When the Macintosh and network printer are in the same network, check above items again. Otherwise check whether the router can support AppleTalk protocol. If the router can not support the AppleTalk protocol, then ask the network manager to solve this problem.

Network Problems

Problem	Solution
The printer drops letters.	<ol style="list-style-type: none"> 1. Make sure the PS option is installed in your printer correctly. 2. Make sure the SIMM provided with PS option is installed correctly. Check that the total memory is 12MB by printing a self-test page.

4.9.3 WINDOWS PROBLEMS

Problem	Solution
After installing PortThru, the print server name is not displayed under New Print Server in SyncThru.	<ol style="list-style-type: none"> 1. Verify that the printer power switch is turned on and the 'READY' message is displayed on the printer front panel. 2. Verify that the LAN cable is plugged into the PortThru card. 3. Verify that the second LED on the PortThru card blinks. <ul style="list-style-type: none"> ▪ If the second LED blinks regularly, turn off the printer, then turn it back on. If the problem continues, contact your network administrator. ▪ If the first LED on the PortThru card does not blink, check that the card is installed snugly. If the problem continues, contact your network administrator. 4. Confirm whether the print server and the PC which searches for the New Print Server is on the same LAN. If you want to search for a New Print Server, your PC and the print server should be on the same LAN.
The print server name is displayed, but the test page is not printed.	Select the Network menu from the front panel menus. Check that the test page is printed. If the

Problem	Solution
	<p>Network menu is not displayed, or the test page is not printed, turn off the printer, then turn it back on.</p>
<p>Firmware upgrade process is completed. But upgrading is not executed.</p>	<p>An IP address should be assigned to upgrade the Firmware. Make sure that IP address is entered in Print Server. If an IP address is not entered, reassign it and try again.</p>
<p>SyncThru is unable to automatically detect printers.</p>	<ol style="list-style-type: none"> 1. Check whether LAN cable is connected to the printers. <ul style="list-style-type: none"> ▪ Check whether LAN cable is connected to the printers yourself. ▪ Make sure that there are connected printers shown in network neighborhood. If not, check the communication status of the printers. ▪ If an IP address is assigned to the computers, try ping command. 2. If the protocols of NPC are disabled, DLC/LLC should be installed in the computers. <ul style="list-style-type: none"> ▪ If SyncThru is unable to detect printers with DLC/LLC installed in the computers, check whether NPC and PC are on the same LAN. ▪ If LAN is connected by routers, SyncThru is unable to detect the printers. 3. If more than one of the protocols of NPC are enabled and DLC/LLC is installed in the

Network Problems

Problem	Solution
	<p>computers, check NPC and PC are on the same LAN.</p> <ul style="list-style-type: none"> ▪ If LAN is connected by routers, SyncThru is unable to detect the printers. In this case, one of the protocols which are enabled in NPC should be installed in the computers. <p>4. In case that the protocol which is enabled in NPC is installed in the computers:</p> <ul style="list-style-type: none"> ▪ If TCP/IP installed, check entry values of IP address, subnet mask and default gateway.
The printer does not print.	Try Add a Port.

4.9.4 SYNCTHRU INSTALLATION PROBLEMS

Problem	Solution
"File Transfer Error" message appears when you execute Installation.	<ol style="list-style-type: none"> 1. Make sure the previously installed SyncThru is uninstalled. 2. If SyncThru is uninstalled, restart your PC. 3. If the problem continues, In Windows 95/98, delete the "sammon.dll" file in the system directory of Windows in MS-DOS mode, restart Windows and reinstall it. In Windows NT, stop the spooler service with 'Services' in Control Panel, delete the "sammon.dll" file in the system32 directory of Windows NT, start spooler service and reinstall it.

Problem	Solution
"Unable to add the Port list of ports" message appears, when you add a port.	Verify that your PC restarts after installing SyncThru.

4.10 PERIODIC DEFECTIVE IMAGE

If defective images regularly occur in print-outs, it may be due to a defective or damaged roller.

Refer to the table below and check the condition of the roller.

No	Roller	Defective image	Typical defect
1	OPC Drum	75.5 mm	White spot on black image or black spot, image ghost
2	Charge Roller	37.7 mm	Black spot
3	Supply Roller	53.2 mm	Light or dark horizontal image band
4	Development Roller	39.2 mm	Horizontal image band, image ghost
5	Transfer Roller	47.1 mm	Image ghost
6	Heat Roller	88.9 mm	Black spot and image ghost
7	Pressure Roller	101.3 mm	Black spot on the backside

Periodic Defective Image

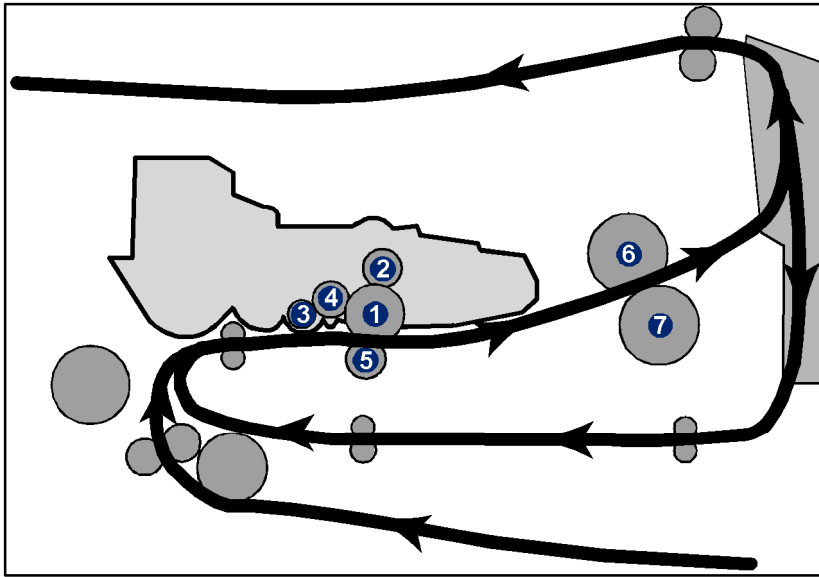

- 1 OPC Drum
- 2 Charge Roller
- 3 Supply Roller
- 4 Development Roller
- 5 Transfer Roller
- 6 Heat Roller
- 7 Pressure Roller

g960t541

Trouble-
shooting

SERVICE TABLES

5. SERVICE TABLES

5.1 TECH MODE

5.1.1 HOW TO ENTER TECH MODE

In service (tech) mode, the technician can check the machine and perform various tests to determine the cause of a malfunction.

While in Tech mode, the machine still performs all normal operations.

To enter Tech Mode

To enter Tech Mode, press the following keys in sequence:

"Menu" → "#" → "1" → "9" → "3" → "4" → "Menu"

The display shows "Tech Mode> Tech menu"

Press "OK" to enter Tech menu.

To exit the Tech Mode

To exit Tech Mode, press the following keys in sequence:

"Stop" → "Menu" → "#" → "1" → "9" → "3" → "4"

5.1.2 TECH MODE

There are several function items in Tech Mode for servicing. The list below shows all items.

Select Function with "◀" "▶" keys and press "OK" key to enter each item.

Press "Back" key to return to the previous step.

Note

- The display shows "Ready to Copy" after 30 seconds without any operation.
- Press "menu" key to show "Tech menu" on the display.

Function	Item	Contents
Data Setup	Send Level	9-15 dBm
	DTMF Level (high/low)	0-15
	Pause Time	1-9
	Dial Mode	Tone/Pulse

Tech Mode

Function	Item	Contents		
	Modem Speed	33.6 / 28.8 / 14.4 / 12.0 / 9.6 / 4.8 (K bps)		
	Error Rate	5% / 10%		
	Clear All Memory	Select Country		
	Clear Count	Enter Password (1934 enter)	Total Page CNT	
			FLT Scan CNT	
ADF Scan CNT				
Used Toner CNT				
Machine Test	Switch Test			
	Modem Test			
	Dram Test	Result and Memory size		
	Rom Test	English Firmware version		
	Pattern Test	1~7/ all		
	Shading Test	Shading and Print /Print		
Report	All Report			
	Protocol			
	Configuration			
	Error Info			
	Usage Page	*1		
	Component Check	*2		
	Service Support			
	Supplies Info			



- *1: Country setting, F/W upgrade and test pattern procedures.
- *2: Switch test, modem test, DRAM test, ROM test, pattern test and shading.

5.1.3 DATA SETUP

Send Level

This lets you set the level of the transmission signal. The Tx level should normally be under -12 dBm.

Dial Mode

Select the dialing mode according to the user's line status.

- Dial: Electrical type of dial (**Default**)
- Pulse: Mechanical type of dial

Modem Speed

This lets you set the maximum modem speed. The value of the maximum modem speed is checked for both transmitter and receiver when the fax makes communication with a remote set. The lowest value is used. It is best set at 33.6Kbps (default).

Error Rate

The Baud rate automatically adjusts to 2400 bps when the error rate goes past the set value. This ensures that the error rate stays below the set value.

You can select the rate between 5% and 10%.

Clear All Memory

Use this function to reset the system to the default set at the factory.

This function resets the system to the initial value when the machine does not work correctly. Values are set to the default values. The machine will not keep data set by the user. This procedure does not clear the counter data values.

<Procedure>

1. Set the [MEMORY CLEAR] in tech mode.
2. Push the ENTER button.
3. The country name will show. You can see all available countries when you scroll by pressing the left key or right key.
 - EU default (UK)
 - North America default (USA/Canada)
 - Asia default (Singapore)
 - China default (China)

Tech Mode



- You cannot change the default country values.

4. Push the ENTER button. This clears the memory. Then it changes it to the country code that you set.



- Do this procedure after you replace the main board. If you do not do this procedure, the system will not operate correctly.

Flash Upgrade

The firmware upgrade has these functions:

- Local and remote.

For the firmware updating procedure, refer to "Firmware Upgrade".

5.1.4 MACHINE TESTS

Switch Test

This lets you test the keys on the operation panel. The result shows on the LCD display when you press a key.

Modem Test

This lets you hear various transmission signals from the modem and to check the modem, amplifier and speaker. The modem part of the main board, amplifier, speaker or speaker harness is faulty if no transmission signal sound is heard.

DRAM Test

This lets you test the machine's DRAM. The LCD shows 'OK' if the memory operates correctly.

ROM Test

This lets you test the machine's ROM. The result and the software version show on the LCD display.

Pattern Test

The pattern printout lets you make sure that the printer mechanism operates correctly. This function is for factory use only.

Shading Test

The lets you set the optimum scan quality determined by the specific characteristics of the CCD (Charge Coupled Device). Do the following procedure to check the condition of the CCD unit if copy image quality is poor.

Procedure

- 1) Select the "Shading test > Shading & Print" at the Tech Mode.
- 2) Press "OK" key twice.
- 3) CCD shading profile gets printed after the image gets scanned.

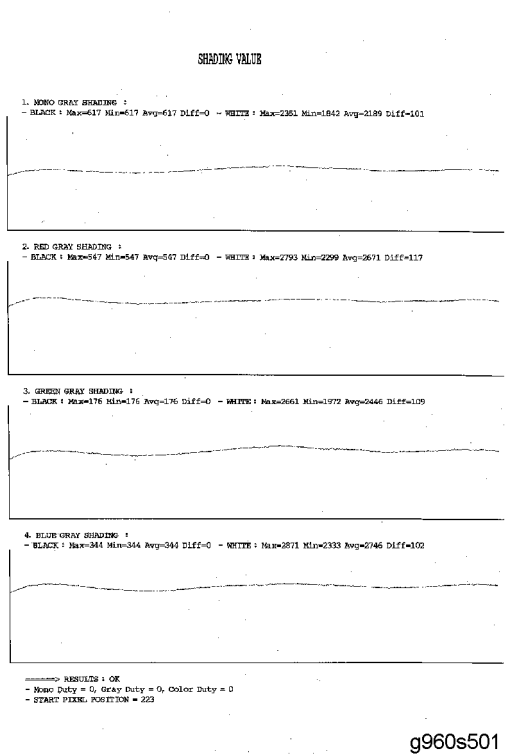

- 4) The CCD is defective if the printed image is not the same as the sample image shown

Note

- Make sure the cover is closed when you test the CCD.

5.1.5 REPORTS

Protocol List

This shows the sequence of the CCITT group 3 T.30 protocol for the most recent sending or receiving operation. This list lets you check for send and receive errors.

Configuration Report

This shows a list of the user system data settings and tech mode settings.

5.2 EDC (ENGINE DIAGNOSTIC CONTROL) MODE

5.2.1 EDC SETUP

EDC (Engine Diagnostic Control) is utilized to test and check whether each of the functions of the machine and hardware modules are normal or not. All of the test functions are controllable via the keys and LCD window on the panel.

5.2.2 OPERATING EDC

In order to enter the EDC mode, the access method should be guarded because this mode is only used for engineers (or similarly qualified people), and is not for end users.

- Entering the mode, the message, "COMPONENT TEST " is displayed.
- In this mode, a service engineer should press the "Menu" key to search for each function.

Entering EDC

1. Check that the printer is turned on.
2. Wait until the printer reaches ready mode.
3. Press the following six keys in order within two seconds:
"Menu" → "stop" → "left" → "Back" → "OK" → "Right"
4. Confirm that the message "COMPONENT TEST" is displayed.
5. Press "Menu" key.
6. Follow the usage instructions displayed for each function.



- The procedure and content above may vary, depending on the situation.

Exiting EDC

Press "Stop/Clear" key to exit the EDC.

5.2.3 COVER OPEN/CLOSE STATUS

This function is to check the status of the cover or door open/close.

Usage

1. Press the arrow keys "◀▶" until "0.Cover Status" message is displayed on the panel.
2. Press the "OK" key.
3. Press the arrow keys "◀▶" to find a desired function (Refer to the table below).
4. Press the "OK" key.
5. Press the "OK" key to execute the function or "Back" to return to the previous step.

Function

Function Name	Description	Display (LCD)
Front Cover	"Open" shows when cover is open. "Closed" shows when cover is closed.	Front Cover [Closed]/[Open]
Fuser Door	"Open" shows when fuser door is open. "Closed" shows when fuser door is closed.	Fuser Door [Closed]/[Open]

 **Note**

- The procedure and content above may vary, depending on the situation.

5.2.4 SENSOR STATUS

These Functions are to check a current state (normal or not) of each Sensor.

Usage

1. Press the arrow keys "◀/▶" until "1.Sensor Status" message is displayed on the panel.
2. Press the "OK" key.
3. Press the arrow keys to find a desired function. (Refer to the table below)
4. Press the "OK" key.
5. Touch a sensor you would like to test.
6. Check the message on the LCD.

Function

Sensor	Description	Display (LCD)	
		Before touching	After touching
RegiSensor	Check the message on the LCD.	Regi. Sensor [Without Paper]	Regi. Sensor [With Paper]
T1 FeedSensor		T1 Feed Sensor [Without Paper]	T1 Feed Sensor [With Paper]
ExitSensor		Exit Sensor [Without Paper]	Exit Sensor [With Paper]

EDC (Engine Diagnostic Control) Mode

DJam1Sensor		DJam1 Sensor [Without Paper]	Djam1 Sensor [With Paper]
Bypass Empty		Bypass Empty [Empty]	Bypass Empty [Present]
T1 Paper Empty		T1 Paper Empty [Empty]	T1 Paper Empty [Present]
T2 Paper Empty		T2 Paper Empty [Empty]	T2 Paper Empty [Present]

↓ Note

- The procedure and content above may vary, depending on the situation.

5.2.5 MOTOR TEST

These functions are to check the current status.

Usage

1. Press the arrow keys "◀▶" until "2.Motor Test" message is displayed on the panel.
2. Press the "OK" key.
3. Press the arrow keys "◀▶" to find a desired function (Refer to the table below).
4. Press the "OK" key.
5. Press the "OK" key to execute the function.
6. Scroll using the arrow keys "◀▶" and select [OFF], then press the "OK" key to stop the function.

↓ Note

- Press the "Back" key to return to the previous screen at any time during this procedure.

Function Name	Description	Display (LCD)
Main Mtr Nor.	The motor will run at normal speed or stop.	Main Mtr Nor. [ON] / [OFF]
Main Mtr Slow	The motor will run at slow speed or stop.	Main Mtr Slow [ON] / [OFF]

Function Name	Description	Display (LCD)
Exit Mtr Fwd	The motor will run in the forward direction.	Exit Mtr Fwd [ON] / [OFF]
Exit Mtr Bwd	The motor will run in the backward direction.	Exit Mtr Bwd [ON] / [OFF]
Duplex Mtr Fwd	The motor will run in the forward direction or stop.	Duplex Mtr Fwd [ON] / [OFF]
Duplex Mtr Bwd	The motor will run in the backward direction or stop.	Duplex Mtr Bwd [ON] / [OFF]
T2 Feed Motor	The motor will run in the forward direction or stop.	T2 Feed Motor [On] / [OFF]

 Note

- The procedure and content above may vary, depending on the situation.

5.2.6 FAN TEST

These functions are to check the current status of all fans.

Usage

1. Press the arrow keys "◀/▶" until "3.Fan Test" message is displayed on the panel.
2. Press the "OK" key.
3. Press the arrow keys "◀/▶" to find a desired function (Refer to the table below).
4. Press the "OK" key.
5. Press the "OK" key to execute the function.
6. Scroll using the arrow keys "◀/▶" and select [OFF], then press the "OK" key to stop the function.

 Note

- Press the "Back" key to return to the previous screen at any time during this procedure.

EDC (Engine Diagnostic Control) Mode

Function

Function Name	Description	Display (LCD)
Fuser Fan	The fan will run or stop.	Fuser Fan [ON] / [OFF]
Duplex Fan	The fan will run or stop.	Duplex Fan [ON] / [OFF]

Note

- The procedure and content above may vary, depending on the situation.

5.2.7 CLUTCH/SOLENOID

These functions are to check a current state (normal or not) of the solenoids and clutches.

Usage

1. Press the arrow keys "◀/▶" until "4.Clutch/Sol. Test" message is displayed on the panel.
2. Press the "OK" key.
3. Press the arrow keys "◀/▶" to find a desired function (Refer to the table below).
4. Press the "OK" key.
5. Press the "OK" key to execute the function.
6. Scroll using the arrow keys "◀/▶" and select [OFF], then press the "OK" key to stop the function.

Note

- Press the "Back" key to return to the previous screen at any time during this procedure.

Function

Function Name	Description	Display (LCD)
T1 P-up Clutch	The clutch will run or stop.	T1 P-up Clutch [ON] / [OFF]
T2 P-up Clutch	The clutch will run or stop.	T2 P-up Clutch [ON] / [OFF]

Function Name	Description	Display (LCD)
Bypass Clutch	The clutch will run or stop.	Bypass Clutch [ON] / [OFF]
Regi. Clutch	The clutch will run or stop.	Regi. Clutch [ON] / [OFF]

↓ Note

- The procedure and content above may vary, depending on the situation.

5.2.8 FUSER CONTROL

This function is to check a current state (normal or not) of the fuser unit.

Usage

1. Press the arrow keys "◀/▶" until "5.Fuser Ctrl" message is displayed on the panel.
2. Press the "OK" key.
3. Press the arrow keys "◀/▶" to find a desired function (Refer to the table below).
4. Press the "OK" key.
5. Press the "OK" key to execute the function.
6. Scroll using the arrow keys "◀/▶" and select [OFF], then press the "OK" key to stop the function.

↓ Note

- Press the "Back" key to return to the previous screen at any time during this procedure.

Function Name	Description	Display (LCD)	Remarks
Temp Control	The fuser unit will control the power for fixing and display the current temperature on the panel. The target temperature is 160°C.	Temp Control [OFF] / [ON] [xxx]	[xxx] is a current temperature.
Fuser Temp. A	The ADC will be displayed on the panel.	Fuser Temp [xxx]	[xxx] is its ADC.

EDC (Engine Diagnostic Control) Mode

↓ Note

- The procedure and content above may vary, depending on the situation.

5.2.9 LSU

These functions are to check a current state (normal or not) of the Laser Scanning Unit.

Usage

1. Press the arrow keys "◀/▶" until "6.LSU Control" message is displayed on the panel.
2. Press the "OK" key.
3. Press the arrow keys "◀/▶" to find a desired function (Refer to the table below).
4. Press the "OK" key.
5. Press the "OK" key to execute the function.
6. Scroll using the arrow keys "◀/▶" and select [OFF], then press the "OK" key to stop the function.

↓ Note

- Press the "Back" key to return to the previous screen at any time during this procedure.

Function Name	Description	Display (LCD)
LD Power 1	The LD will have the previously saved value.	LD Power 1 [OFF] / [ON]
LSU Motor	The motor will run or stop.	LSU Motor [OFF] / [ON]
LSU Motor Read	Ready to print (laser diode on, Stable polygon motor speed) the message, TBA	LSU Motor Rdy [OFF] / [ON] / [0/1]
LSU Hsync	Hsync signal check	LSU motor Rdy [OFF] / [ON] / [0/1]

↓ Note

- Hsync: If the receiving part in LSU detects the beam, Hsync is generated.

5.2.10 BIAS CONTROL

These functions are to check whether the control for HVPS is normal or not.

Usage

1. Press the arrow keys "◀▶" until "7.Deve Control" message is displayed on the panel.
2. Press the "OK" key.
3. Press the arrow keys "◀▶" to find a desired function (Refer to the table below).
4. Press the "OK" key.
5. Press the "OK" key to execute the function.
6. Scroll using the arrow keys "◀▶" and select [OFF], then press the "OK" key to stop the function.

 **Note**

- Press the "Back" key to return to the previous screen at any time during this procedure.

Function

Function Name	Description	Display (LCD)	Remarks
THV Plus Bias	The bias will have the previously saved value.	THV Plus Bias [OFF] / [ON]	
THV Minus Bias	The bias will have the previously saved value.	THV Minus Bias [OFF] / [ON]	
DEV Bias	The bias will have the previously saved value.	DEV Bias [OFF] / [ON]	
MHV Bias	The bias will have the previously saved value.	MHV Bias [OFF] / [ON] / [0]	

 **Note**

- The procedures and content above may vary, depending on the situation.

5.3 FIRMWARE DOWNLOAD

5.3.1 FIRMWARE UPGRADE

The Firmware Upgrade function has two methods, Local and Remote.

Local

Firmware upgrade utility



- Only support USB, not Network.

1. Connect USB cable.

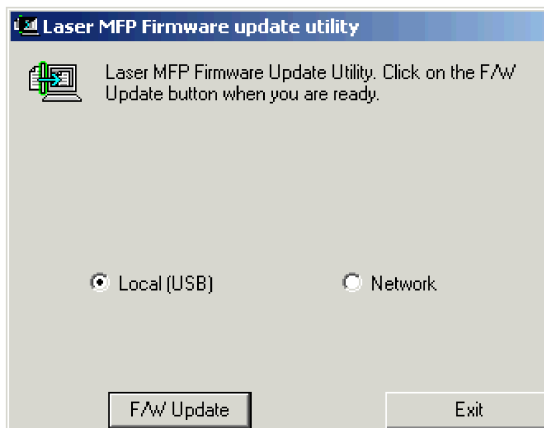

2. Double-click the upgrade utility (*.exe) and then the display shown above appears.

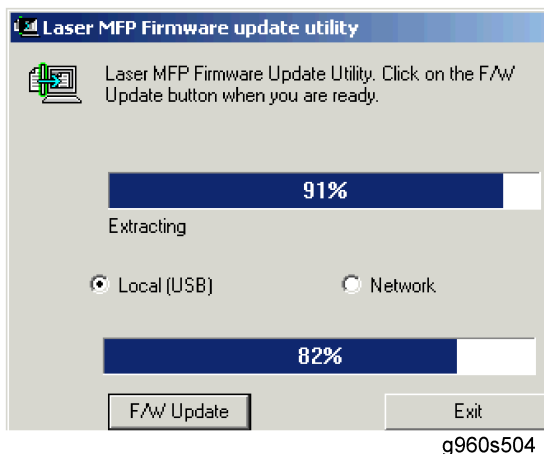

3. Select “**Local (USB)**” and Click “**F/W Update**”.
4. “FLASH UPGRADE...” is displayed on the LCD for about 3 minutes.
5. The messages shown below are displayed in turn on the LCD for about 5 minutes.
 - “Update FW Image...”
 - “Please Wait...”

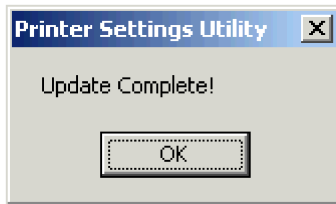

g960s506

6. Wait till machine reboots automatically.

Remote

Web Image Monitor Type104 mode

1. Print out the System data list for back up the data and setting.
2. Download the Firmware on the PC.
3. Access the .Web image Monitor Type 104 with the correct IP address.

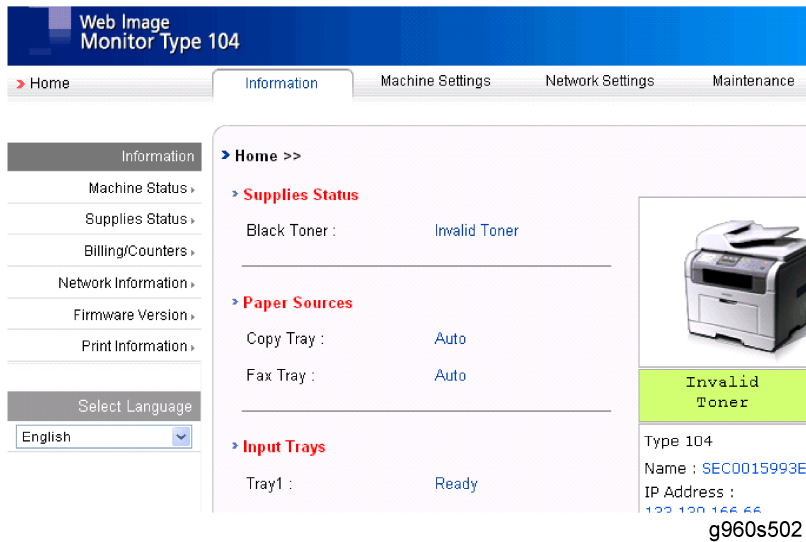

g960s502

1. Select. Maintenance as shown above.

Firmware Download

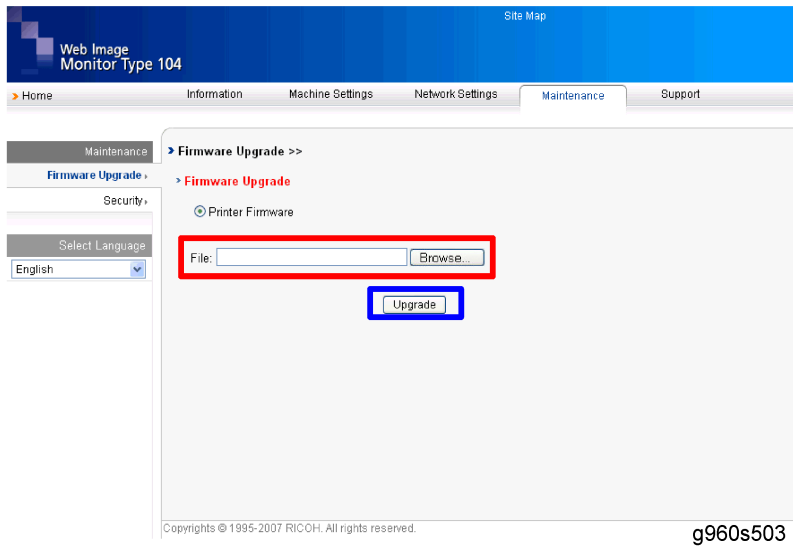

2. Click the browse button and select the Printer Firmware file you saved in the PC.
3. Click the Upgrade Button.
4. Make sure the firmware was completely updated.

↓ Note

- Do not turn off the power of the machine while updating the FW.

DETAILED DESCRIPTIONS

6. DETAILED DESCRIPTIONS

6.1 SYSTEM DESCRIPTIONS

6.1.1 FEEDING SECTION

Feeding Method: Universal Cassette Type

Feeding Standard: Center Loading

Feeding Capacity: (Cassette) 250 Sheets (75g/20lb Standard Paper)

6.1.2 TRANSFER UNIT

The transfer assembly consists of Transfer Roller and spire gear. The transfer roller delivers the toner of the OPC drum to the paper.

6.1.3 DRIVER UNIT

Main Motor is for the cassette, by-pass tray and toner cartridge

Exit Motor is for the fusing unit, exit roller and initial duplex feeding

Duplex Motor is for the duplex feeder

6.1.4 FUSING UNIT

Fusing Type: [Halogen Lamp (R2) E-Coil type (Elbert) / Halogen Lamp (Dove)]

Heat Roller: [ϕ 28.3 with 0.1 Crown]

Pressure Roller: [Electrically conductive]

Thermistor - Temperature Detecting Sensor

Thermostat - Overheat Protection Device

Media Separating System: Teflon Coating with SUS Plate Claw System

Overheat protection:

1st: H/W cuts off when overheating is detected

2nd: S/W cuts off when overheating is detected

3rd: Thermostat cuts off the power

Trouble	Temperature Control
Open Heat Error	90°C or less for 45 seconds at Warm-up
Over Heat Error	230°C or more for 10 seconds or

System Descriptions

	240°C or more for 5 seconds
Low Heat Error	Stand-by: 130°C or less for 10 seconds Operating: 35°C or less for 7 seconds at consecutive tow pages printing

Safety device

Power to the fusing unit is cut when the front cover is open.

Overheating safety device for customer's safety.

Surface temperature of the fusing cover is kept under 80°C.

6.1.5 LSU (LASER SCANNING UNIT)

LSU consists of LD (Laser Diode) and polygon motor control. When the controller generates, the printing signal LD will turn on and Polygon motor starts. If the receiving part in LSU detects the beam, Hsync is generated. When the rotation of the polygon motor is steady, it is time when the LSU is ready status for printing. If either of two conditions is not satisfied, LSU error is expected.

Trouble	Failure Analysis
Polygon Motor Error	No steady rotation of Polygon Motor
Hsync Error	In spite of steady rotation of Polygon Motor, no generation of the Hsync signal

6.1.6 SCANNER

Scanning Method: Color CCD (600 x 1200 dpi)

Scan speed: SDMP (Single Document Multiple Copy)" 28cpm/MDSP (Multi-all document Multiple Copy)" 20cpm

6.1.7 TONER CARTRIDGE

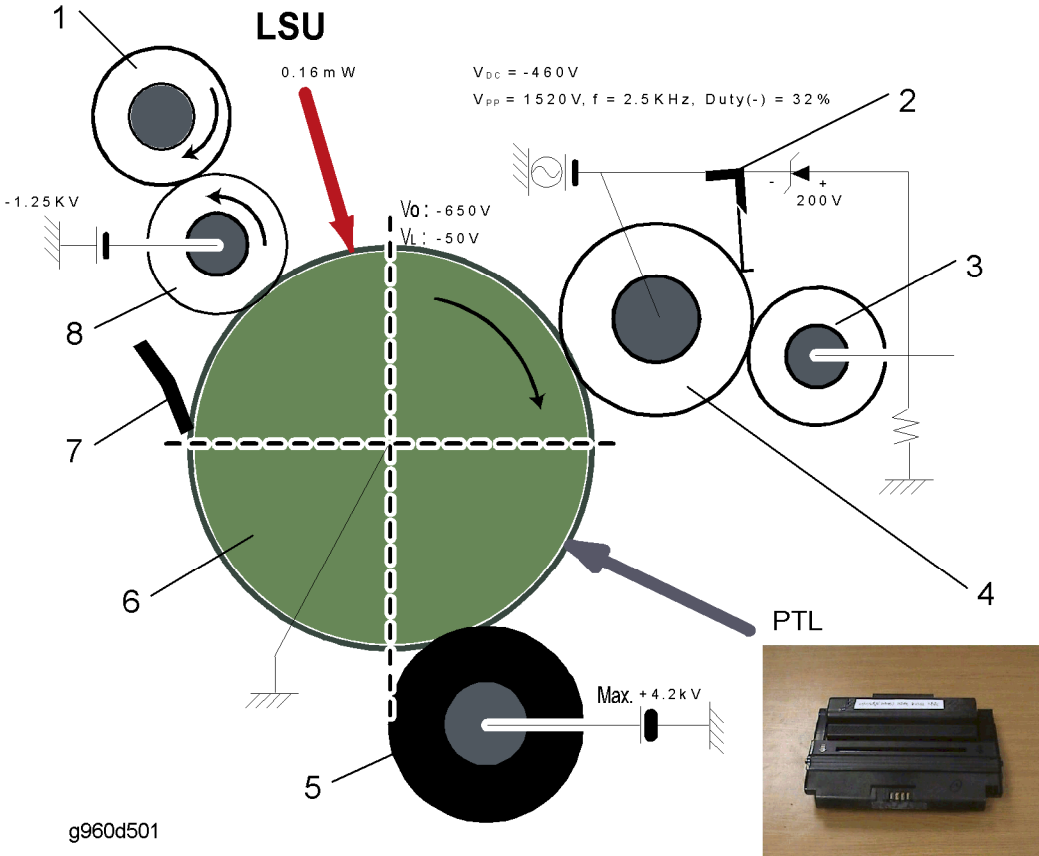

1. Cleaning Roller	5. Transfer Roller
2. Doctor Blade	6. OPC Drum
3. Supply Roller	7. Cleaning Blade
4. Development Roller	8. Charge Roller

- OPC Cleaning: Mechanical Cleaning with the cleaning blade.
- Recycled toner: Space for recycled toner.
- No shutter for protecting the OPC Drum

The OPC unit and the developer unit are contained within the toner cartridge. The OPC unit consists of the OPC drum and charging roller, and the developer unit consists of the toner, toner cartridge, supply roller, developing roller, and the blade.

ID is classified by CRUM in AIO and firmware.

Detailed Descriptions

⇒ New Toner Detection

A new supply AIO cartridge has an ID chip. The machine knows a new cartridge has been installed when the chip gets detected. When the new cartridge is installed in the machine, the machine automatically detects by the chip that the cartridge is brand-new. Then the machine resets the total dot counter (TOTAL TONER COUNT) and CRU print counter (Cru Prints). And increments the counter for counting the number of CRU replaced (Replaced Toner Counts). Only the case when the "Replaced Toner Counts" was 0, the CRU currently installed is regarded as starter CRU. In this condition, threshold to detect toner end is shorter than that for supply CRU.

⇒ Toner End Detection

The machine does not have a toner end sensor. The machine checks the amount of toner with software. The machine counts and adds up black dots as toner consumption. For example, the following occurs when the machine prints 5% of black rate chart

- Starter cartridge: Approx. 4, 750, 000, 000 dots will be added.
- Supply cartridge: Approx. 7, 500, 000, 000 dots will be added.

When the total number of dots gets to a pre-programmed figure (as for toner near-end), the machine shows "TONER LOW". After another period of dots has been counted up, the machine finally shows "TONER EMPTY" (as for toner end), and the machine stops printing. You can check the total dot counts from the current cartridge in the System Data List in TECH mode.

6.1.8 DUPLEX UNIT

Available Paper sizes: Letter, Oficio, Legal, Folio, and A4

6.1.9 OPTIONAL TRAY (SCF)

For customer convenience in managing paper

Capacity: 250 sheets

6.1.10 CONTROLLER

The main controller consists of ASIC (CHORUSm) parts, Memory parts, Engine Interface parts and functions as Bus Control, I/O Handling, drivers & PC Interface by CPU.

The Engine Board and the Controller Board are in one integrated board, which consists of (functionally) the CPU section and the printing section. The CPU handles bus control, I/O, drivers, and PC interface. The main board sends current image and video data to the LSU and controls the electro photography process for printing, as well as operation of motor circuits (paper feed, etc.), clutches, pre-transfer lamp, and fans.

Signals from the paper feed jam sensor and paper empty sensor are directly input to the main board.

6.1.11 ELECTRICAL COMPONENTS

Input Circuit Sensor

Paper Empty Sensor:

The Paper Empty Sensor, via an actuator, senses whether there is paper in the cassette or not. When there is no paper, this is indicated by the Status lamp changing from green to red.

By-pass Sensor

By operation of an Actuator on the frame, the by-pass Sensor (Photo interrupter) on the HVPS transmits the paper condition to the CPU (whether it's empty or not).

Paper Feed Sensor

When paper passes the actuator (feed sensor part), it detects the signal of the Photo interrupter; informs the paper feeding state to the CPU.

If the feed sensor doesn't detect paper within one second after the paper is fed, paper Jam0 occurs (indicated by the Status lamp turning red). Whether developer is inserted or not is detected by the AIO sensor. After the developer is installed, the sub-AIO sensor can read toner cartridge information from contact with the AIO sensor. If the toner cartridge information is invalid, it will be indicated as invalid by a red Status light.

Paper Exit Sensor

HVPS exit sensor detects whether paper successfully exits machine by monitoring the on/off time of the sensor and indicating JAM2 by the Status lamp turning red when there is a jam.

Cover Open Sensor

The Cover Open sensor is located on the HVPS. After the front cover is opened, +24VS (DC fan, Solenoid, Main Motor, Polygon motor part of LSU and HVPS), which is supplied to each unit, is cut off. When cover-open is sensed, the Status lamp will turn to red.

DC Fan / Solenoid Control

This is driven by a transistor and controlled by D14 (FAN MAIN), E16 (FAN DUPLEX), C23 (PICK-UP CLUTCH), C18 (REGI CLUTCH), and D15 (BY-PASS CLUTCH) of the CPU.

The fan is driven by turning on the TR, and is turned off when the sleep mode is selected.

There are three solenoids, which are driven by: paper pick-up; registration; and by-pass signals.

Motor Control

The main motor control circuits are on the main motor drive unit. The main controller has interfacing circuits - there is a motor driver IC on the motor control board of the motor drive unit. A motor driver IC is used in this case.

6.1.12 SMPS AND HVPS BOARD

The SMPS supplies DC Power to the System.

It takes 110V/220V and outputs the +5V, +24V to supply the power to the main board. The HVPS board creates the high voltage of THV/MHV/Supply/Dev and supplies it to the developer part for creating the best condition for displaying the image. The HVPS part takes 24V and outputs high voltage for THV/MHV/BIAS, and the outputted high voltage is supplied to the toner, OPC cartridge, and transfer roller.

SMPS (Switching Mode Power Supply)

This is the power source for the entire system. It is assembled as an independent module, and is mounted at the side.

It consists of the SMPS section, which supplies the DC power for driving the system, and the AC heater control section, which supplies the power to fuser. SMPS has two output channels. Which are +5V and +24V.

SPECIFICATIONS

7. SPECIFICATIONS

7.1 GENERAL SPECIFICATIONS

7.1.1 GENERAL SPECIFICATIONS

Configuration	Desktop	
Paper capacity	Main tray	250 sheets
	By-pass tray	50 sheets
	Optional paper feed unit	250 sheets
	Output tray	Face down: 150 sheets
Face up: 1 sheet		
Paper size	Main tray	A4, A5, Letter, Legal, Folio, Executive, Oficio, B5
	By-pass tray	A4, A5, A6, Letter, Legal, Folio, Executive, Oficio, B5, 3" x 5", Monarch, No.10, DL, C5, C6 Custom size: Max.: 216 x 356mm (8.5 x 14 inch) Min.: 76 x 127mm (3 x 5 inch)
Paper weight	Main tray	60-90 g/m ² (16-24 lb)
	By-pass tray	60-163 g/m ² (16-43 lb)
ADF	Paper weight	47-105 g/m ² (12.5-28 lb)
	Capacity	50 sheets
	Width	142 x 216mm (5.6 x 8.5 inch)
	Length	148 x 356mm (5.8 x 14 inch)

General Specifications

	Thickness	0.075 - 0.13 mm (0.003 - 0.005 inch)
Machine size (W x D x H)	460 x 435 x 450 mm (17.7 x 17.1 x 18 inch)	
Weight	Net Weight ; 18.9 Kg(41.6 lb) Gross Weight; 22 Kg Net with a starter AIO ctrg. Gross; with package	
Operation panel	16 x 2 characters	
Total Counter	Electronic Counter	
Energy Saver Mode	Selectable 5/15/30/45 minutes	
Power consumption	Average	520 W
	Power save mode	20 W (energy start compliant)
Power supply	Low voltage	110 - 127 V
	High voltage	220 - 240 V
	Input frequency	50/60 (\pm 3Hz)
Noise	Printing	54 dB
	Copy	55 dB
	Standby	39 dB
Warm up time	From standby	20 seconds
	From cold status	25seconds
ACV	1,400 prints	
MCV	4,000 prints	
Machine life	5 years, 250,000 prints (whichever comes first)	
Yield parts	Pick-up roller	150 K prints
	Friction Pad Ass'y	150 K prints

	Transfer roller	70 K prints
	Fuser unit	80 K prints
Environmental Standard	US version: Energy star program	
	EU version: Energy star program	
Energy Saver Mode	Default 30	
	Selectable 5/10/15/30/60/120	

7.1.2 PRINTER

Print speed	Simplex	30 ppm LT, 28 ppm A4 (600 dpi)	
	Duplex	21 ppm LT, 19 ppm A4 (600 dpi)	
Printer drivers	PCL6, PS3		
Auto emulation sensing	Supported		
Font	45 Scalable, 1 Bitmap		
Energy Save Mode	5/10/15/30/45 minutes		
Resolution	Normal	600 x 600 dpi	
	RET	1200 x 1200 dpi	
Toner save mode	Supported		
First print time	From standby	8.5 seconds	
	From cold status	33.5 seconds	
Duplex print	Supported		
Printable area	208 x 273 mm (Letter)		
Halftone grayscales	256 levels		
Interface option	IEEE1284/ USB 2.0/ Ethernet 10/ 100 base Tx (Embedded type)		

General Specifications

Network	Protocol	TCP/IP, NetWare, Ethertalk
CPU	CPU core: over 300 MHz, ARM 920T	
Memory	Standard/ Max.	96/ 320MB
	Type	SDRAM
	Expand Memory Slot Type	SDRAM DIMM
	Compression Technology	Yes
Operation System	Windows 98/Me/NT4.0/2000/XP/2003 Windows Vista Macintosh 10.3-10.4	

7.1.3 SCANNER

Scan method	Color CCD	
Scan speed for data through ADF	Linearity	Approximately 15 seconds (USB 2.0)
	Gray	Approximately 20 seconds (USB 2.0)
	Color	Approximately 30 seconds (USB 2.0)
Scan speed for data through platen	Linearity	Approximately 15 seconds (USB 2.0)
	Gray	Approximately 20 seconds (USB 2.0)
	Color 75/ 300 dpi	Approximately 30 seconds (USB 2.0)
Resolution for scan data	600 x 1200 dpi (optical, mono color) Enhanced: 4800 x 4800 dpi	
Halftone	256 levels	
Scan area	Platen	216 x 297* mm (8.5 x 11.69 inch)

General Specifications

	ADF	216 x 326* mm (Legal)
Scan to	Application, USB	
Scan depth	Color: 24 bit	
	Monochrome: 1 bit for line art, 8 bit for grayscale	

*: Effective scanning width is 208 mm.

7.1.4 COPIER

Copy resolution	Scan	Text, Text/Photo: 600 x 300 Photo: 600 x 600 (Platen), 600 x 300 (ADF)
	Print	600 x 600 dpi
First copy time	From standby	8.5 seconds: Platen
		15 seconds: ADF
	From cold status	33.5 seconds
Copy speed (letter)	SDMC* ¹	Letter: 30 cpm A4: 28 ccm
	MDMC* ²	20 cpm (A4)
Original alignment	Platen	Rear left
	ADF	Center
Zoom	Platen	25% - 400%
	ADF	25% - 100%
Multi-copy	1 - 99	
Copy mode	Text, Mixed, Photo (all supported)	
Preset	Supported	

General Specifications

Darkness control	3 levels (LED)		
Collation copy	Supported: 600 x 300 dpi (ADF only)		
Auto return to default mode	Supported: (off/15/30/60/180 seconds)		
Changeable default mode	Contrast, image, reduce/enlarge, number of copies		
Special copy	N-up	2-up, 4-up	ADF only
	Auto fit copy	Supported (Platen only)	
	2-sided copy	Supported (Platen only)	
	Clone	Supported (Platen only)	
	Poster	Supported (Platen only)	
Maximum original size	Max. Document Width: Max. 216 mm (8.5") Effective Scan Width: Max. 208 mm (8.2")		
Scan Depth	Color: 24 bit B&W: 1 bit Linearity, 8 bit for Gray scale		
TWAIN OS	Windows: 98 SE/ ME/ NT 4.0/ 2000/ XP/ 2003 Macintosh: OS 10.3, 10.4		

*1: SDMC means "Single Document Multiple Copy".

*2: MDMC means "Multi-all document Multiple Copy".

7.1.5 TELEPHONE

Handset	No
On hook dial	Supported
Search	Supported (phone book)

1 touch dial	30 locations
Speed dial	200 locations (00 - 199)
Telephone answering device I/F	Supported
Tone/Pulse	Supported (selected in Tech Mode)
Pause	Supported
Auto redial	Supported
Last number redialed	Supported
Distinctive ring	Supported
Caller ID	No
External phone interface	Supported
Report and list print out	Tx/Rx Journal: Supported
	Confirmation: Supported
	Auto dial list: Supported
	System data list: Supported
Sound control	Ring volume (Off, Low, Medium, High)
	Key volume (On, Off)
	Alarm volume: (On, Off)
	Speaker (On, Off)

7.1.6 FAX

Compatibility	ITU-T, G3
Communication system	PSTN/PABX

General Specifications

Modem speed	33.6 Kbps	
Compression	MH/MR/MMR/JPEG/JBIG	
Color fax	Supported (send only)	
Error correction mode	Supported	
Resolution	Standard	203 x 98 dpi
	Fine	203 x 196 dpi
	Super fine	300 x 300 dpi
Scan speed (ADF)	Approx. 2.5 seconds/LT (regardless of resolution)	
Duplex fax print out	Yes (printed on both sides of paper)	
Multiple page scan	21 ppm/LT	
Receive mode	Fax, TEL, Ans/Fax, DRPD	
Memory	Capacity	6 MB (optional memory not supported)
	Max locations to store one group dial	229 locations
	Fax forward	Supported (On, Off)
	Broadcasting	Supported (up to 239 locations)
	Cover page	Not supported
	Delayed fax	Supported (Tx only)
	Memory RX	Supported
Functions	Voice request	Not supported
	TTI	Supported
	RTI	Supported
	Polling	Not supported

General Specifications

	Earth/Recall	Not supported
	Auto reduction	Supported
Junk fax barrier	Supported	
Secure receive	Supported	
Memory back-up	Supported (Maximum 72 hours)	
One-touch dial	30 locations	
Speed Dial/Group Dial	230 (including 30 one-touch) / 200 locations	
Summer Time (Day Light Saving Time)	No	

APPENDIX

8. APPENDIX

8.1 BLOCK DIAGRAM

8.1.1 SYSTEM BLOCK DIAGRAM

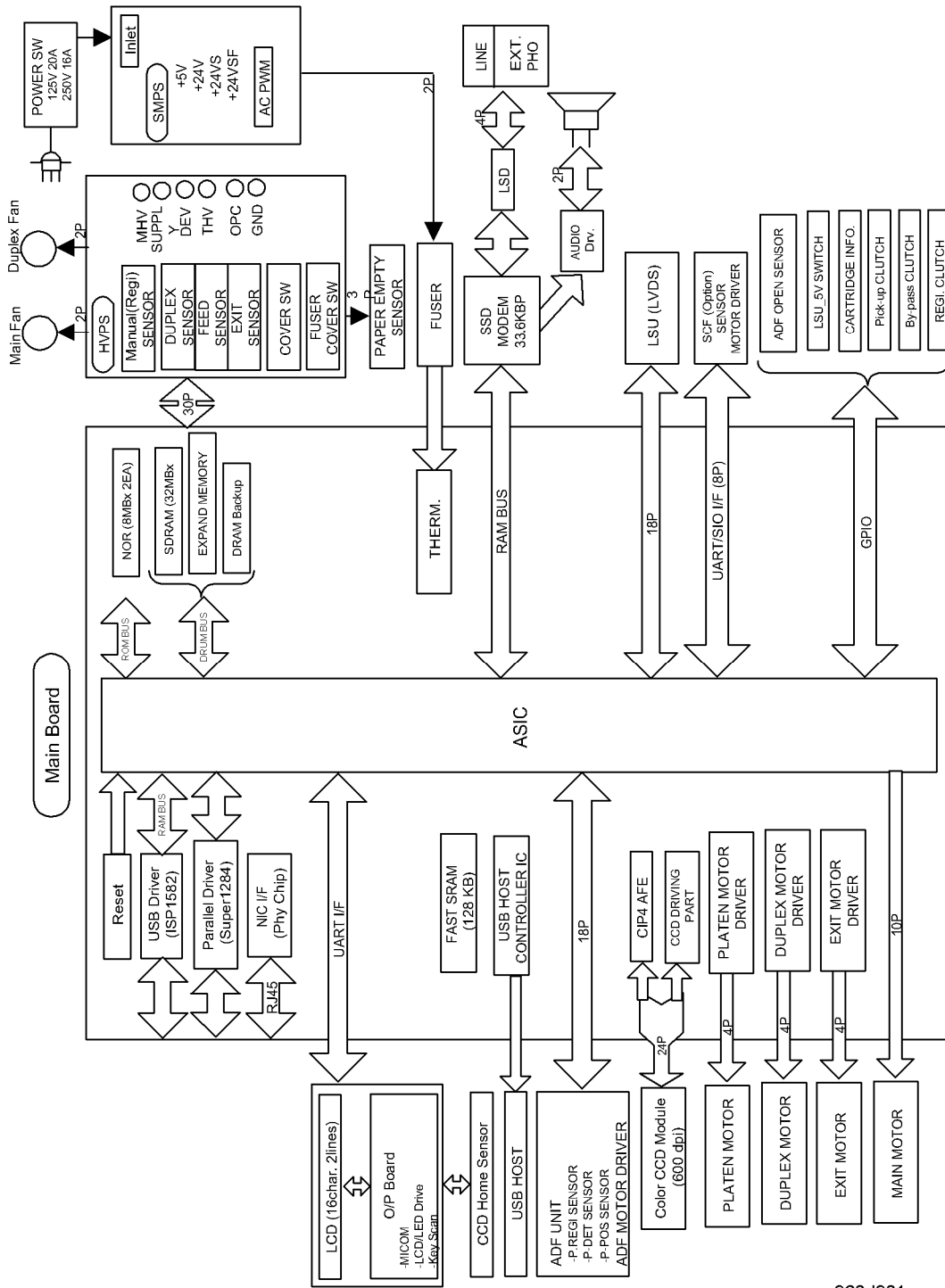

g960d901