

Gestetner[®] **LANIER RICOH[®] SAVIN[®]**

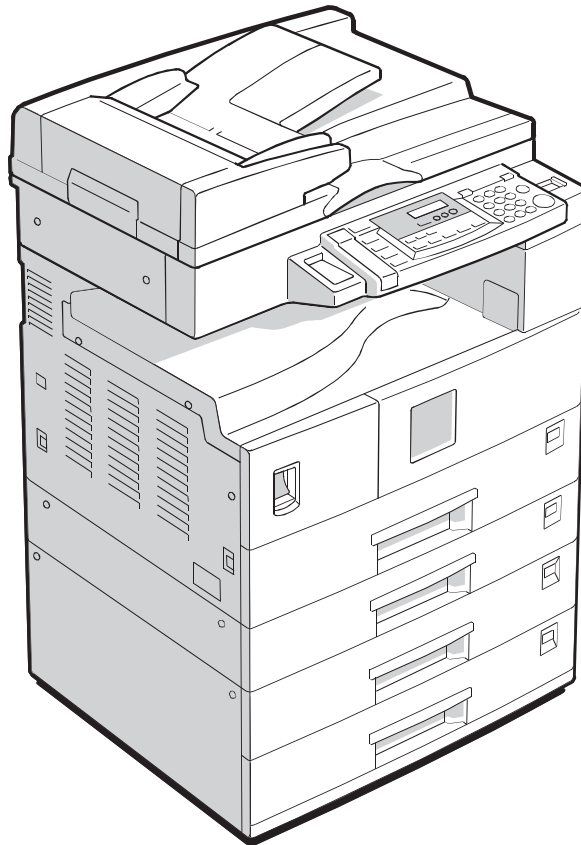

B039/B040/B043/B120

SERVICE MANUAL

RICOH GROUP COMPANIES

001129MIU

Gestetner[®]
LANIER
RICOH[®]
SAVIN[®]

B039/B040/B043/B120
SERVICE MANUAL

RICOH GROUP COMPANIES

Gestetner[®]  **LANIER RICOH[®] SAVIN[®]**

**B039/B040/B043/B120
SERVICE MANUAL**

001129MIU

It is the reader's responsibility when discussing the information contained within this document to maintain a level of confidentiality that is in the best interest of Ricoh Corporation and its member companies.

***NO PART OF THIS DOCUMENT MAY BE REPRODUCED IN ANY
FASHION AND DISTRIBUTED WITHOUT THE PRIOR
PERMISSION OF RICOH CORPORATION.***

All product names, domain names or product illustrations, including desktop images, used in this document are trademarks, registered trademarks or the property of their respective companies.

They are used throughout this book in an informational or editorial fashion only and for the benefit of such companies. No such use, or the use of any trade name, or web site is intended to convey endorsement or other affiliation with Ricoh products.

LEGEND

PRODUCT CODE	COMPANY			
	GESTETNER	LANIER	RICOH	SAVIN
B039	1502	5515	Aficio 1015	2515
B040	1802	5518	Aficio 1018	2518
B043	1802d	5518D	Aficio 1018D	2518d
B120 (RLA only)	1312	LD013	Aficio 1113	-

DOCUMENTATION HISTORY

REV. NO.	DATE	COMMENTS
*	06/01	Original Printing
1	06/03	B120 (RLA only)

B039/B040/B043

TABLE OF CONTENTS

INSTALLATION

1	INSTALLATION	1-1
1.1	INSTALLATION REQUIREMENTS	1-1
1.1.1	ENVIRONMENT	1-1
1.1.2	MACHINE LEVEL.....	1-2
1.1.3	MINIMUM SPACE REQUIREMENTS.....	1-3
1.1.4	POWER REQUIREMENTS	1-3
1.2	COPIER INSTALLATION	1-4
1.2.1	POWER SOCKETS FOR PERIPHERALS	1-4
1.2.2	ACCESSORY CHECK.....	1-4
1.2.3	INSTALLATION PROCEDURE	1-5
1.3	PLATEN COVER INSTALLATION	1-8
1.3.1	ACCESSORY CHECK.....	1-8
1.3.2	INSTALLATION PROCEDURE	1-8
1.4	ARDF INSTALLATION	1-9
1.4.1	ACCESSORY CHECK.....	1-9
1.4.2	INSTALLATION PROCEDURE	1-9
1.5	ADF INSTALLATION.....	1-11
1.5.1	ACCESSORY CHECK.....	1-11
1.5.2	INSTALLATION PROCEDURE	1-11
1.6	TWO-TRAY PAPER TRAY UNIT INSTALLATION	1-13
1.6.1	ACCESSORY CHECK.....	1-13
1.6.2	INSTALLATION PROCEDURE	1-13
1.7	ONE-TRAY PAPER TRAY UNIT INSTALLATION.....	1-16
1.7.1	ACCESSORY CHECK.....	1-16
1.7.2	INSTALLATION PROCEDURE	1-16
1.8	IMB INSTALLATION.....	1-19
1.8.1	ACCESSORY CHECK.....	1-19
1.8.2	INSTALLATION PROCEDURE	1-19
1.9	DRAM INSTALLATION	1-20
1.10	ANTI-CONDENSATION HEATER INSTALLATION	1-21
1.11	TRAY HEATERS.....	1-22
1.11.1	UPPER TRAY HEATER	1-22
1.11.2	LOWER TRAY HEATER (TWO-TRAY MODEL ONLY).....	1-23
1.11.3	TRAY HEATERS FOR THE OPTIONAL PAPER FEED UNITS ...	1-24
1.12	KEY COUNTER INSTALLATION	1-27

PREVENTIVE MAINTENANCE

2	PREVENTIVE MAINTENANCE	2-1
2.1	PM TABLES	2-1
2.2	HOW TO CLEAR THE PM COUNTER.....	2-3

REPLACEMENT AND ADJUSTMENT

3	REPLACEMENT AND ADJUSTMENT.....	3-1
3.1	GENERAL CAUTIONS.....	3-1
3.1.1	PCU (PHOTOCONDUCTOR UNIT)	3-1
3.1.2	TRANSFER ROLLER.....	3-1
3.1.3	SCANNER UNIT.....	3-1
3.1.4	LASER UNIT	3-2
3.1.5	FUSING UNIT.....	3-2
3.1.6	PAPER FEED.....	3-2
3.1.7	IMPORTANT	3-2
3.2	SPECIAL TOOLS AND LUBRICANTS.....	3-2
3.3	EXTERIOR COVERS & OPERATION PANEL.....	3-3
3.3.1	REAR COVER.....	3-3
3.3.2	REAR LOWER COVER (TWO-TRAY MODELS ONLY).....	3-3
3.3.3	COPY TRAY.....	3-4
3.3.4	LEFT UPPER COVER.....	3-4
3.3.5	FRONT UPPER LEFT COVER AND OPERATION PANEL	3-4
3.3.6	RIGHT UPPER COVER	3-4
3.3.7	TOP REAR COVER.....	3-4
3.3.8	LEFT COVER.....	3-5
3.3.9	FRONT LONG COVER	3-5
3.3.10	FRONT RIGHT COVER	3-6
3.3.11	RIGHT REAR COVER.....	3-6
3.3.12	RIGHT DOOR.....	3-7
3.3.13	BY-PASS TRAY.....	3-8
3.3.14	LEFT LOWER COVER (TWO-TRAY MODELS ONLY).....	3-9
3.3.15	RIGHT LOWER COVER (TWO-TRAY MODELS ONLY)	3-9
3.3.16	PLATEN COVER SENSOR.....	3-9
3.4	SCANNER SECTION.....	3-10
3.4.1	EXPOSURE GLASS/DF EXPOSURE GLASS	3-10
	Exposure Glass	3-10
	DF Exposure Glass.....	3-10
3.4.2	LENS BLOCK.....	3-11
3.4.3	EXPOSURE LAMP, LAMP STABILIZER BOARD	3-11
3.4.4	ORIGINAL WIDTH SENSOR.....	3-12
3.4.5	ORIGINAL LENGTH SENSOR.....	3-12
	Sensor Positions.....	3-12
3.4.6	CHANGING THE ORIGINAL SENSOR POSITIONS (8K/16K)	3-13
	Procedure	3-14
3.4.7	SCANNER MOTOR.....	3-15
3.4.8	SCANNER H.P. SENSOR.....	3-15
3.4.9	ADJUSTMENT OF 2ND SCANNER POSITION.....	3-16
3.4.10	ADJUSTMENT OF 1ST AND 2ND SCANNER ALIGNMENT	3-17
3.5	LASER UNIT	3-18
3.5.1	LOCATION OF "CAUTION" DECAL.....	3-18
3.5.2	TONER SHIELD GLASS	3-19
3.5.3	LASER UNIT	3-19

3.5.4	LD UNIT.....	3-20
3.5.5	POLYGONAL MIRROR MOTOR.....	3-20
3.5.6	LASER UNIT ALIGNMENT ADJUSTMENT.....	3-21
3.6	PCU SECTION.....	3-22
3.6.1	PCU.....	3-22
3.6.2	PICK-OFF PAWLS.....	3-22
3.6.3	TONER DENSITY SENSOR.....	3-22
3.6.4	OPC DRUM.....	3-23
3.6.5	CHARGE ROLLER AND CLEANING BRUSH.....	3-24
3.6.6	CLEANING BLADE.....	3-24
3.6.7	DEVELOPER.....	3-25
3.6.8	AFTER REPLACEMENT OR ADJUSTMENT.....	3-26
3.7	TONER SUPPLY MOTOR.....	3-27
3.8	PAPER FEED SECTION.....	3-28
3.8.1	PAPER FEED ROLLER.....	3-28
3.8.2	FRICTION PAD.....	3-28
3.8.3	PAPER END SENSOR.....	3-28
3.8.4	EXIT SENSOR.....	3-29
	Non-duplex Models.....	3-29
	Duplex Models.....	3-29
3.8.5	BY-PASS FEED ROLLER AND BY-PASS PAPER END SENSOR.....	3-30
3.8.6	REGISTRATION ROLLER.....	3-31
3.8.7	BY-PASS PAPER SIZE SENSOR.....	3-32
3.8.8	REGISTRATION CLUTCH.....	3-32
3.8.9	REGISTRATION SENSOR.....	3-33
3.8.10	UPPER PAPER FEED CLUTCH AND BY-PASS FEED CLUTCH.....	3-33
3.8.11	RELAY CLUTCH.....	3-34
3.8.12	RELAY SENSOR.....	3-34
3.8.13	LOWER PAPER FEED CLUTCH (TWO-TRAY MODELS ONLY).....	3-34
3.8.14	VERTICAL TRANSPORT SENSOR (TWO-TRAY MODELS ONLY).....	3-35
3.8.15	PAPER SIZE SWITCH.....	3-35
3.9	IMAGE TRANSFER.....	3-36
3.9.1	IMAGE TRANSFER ROLLER.....	3-36
3.9.2	IMAGE DENSITY SENSOR.....	3-36
3.10	FUSING.....	3-37
3.10.1	FUSING UNIT.....	3-37
3.10.2	THERMISTOR.....	3-37
3.10.3	FUSING LAMP.....	3-38
3.10.4	HOT ROLLER.....	3-38
3.10.5	THERMOFUSE AND THERMOSTAT.....	3-39
3.10.6	HOT ROLLER STRIPPER PAWLS.....	3-39
3.10.7	PRESSURE ROLLER AND BUSHINGS.....	3-40
3.10.8	NIP BAND WIDTH ADJUSTMENT.....	3-41
3.11	DUPLEX UNIT (DUPLEX MODELS ONLY).....	3-42
3.11.1	DUPLEX EXIT SENSOR.....	3-42

3.11.2	DUPLEX ENTRANCE SENSOR	3-42
3.11.3	DUPLEX INVERTER SENSOR.....	3-42
3.11.4	DUPLEX TRANSPORT MOTOR	3-43
3.11.5	DUPLEX INVERTER MOTOR	3-43
3.11.6	DUPLEX CONTROL BOARD.....	3-43
3.12	OTHER REPLACEMENTS	3-44
3.12.1	QUENCHING LAMP.....	3-44
3.12.2	HIGH-VOLTAGE POWER SUPPLY BOARD.....	3-44
3.12.3	IMB (MEMORY BOARD).....	3-45
3.12.4	BICU (BASE-ENGINE IMAGE CONTROL UNIT)	3-45
3.12.5	IOB (I/O BOARD)	3-46
3.12.6	MAIN MOTOR.....	3-46
3.12.7	REAR EXHAUST FAN	3-46
3.12.8	LEFT EXHAUST FAN	3-47
3.12.9	PSU (POWER SUPPLY UNIT)	3-47
3.12.10	GEARBOX	3-48
	Replacement Procedure.....	3-48
	Gear Arrangement Within the Gearbox	3-49
3.13	COPY ADJUSTMENTS: PRINTING/SCANNING.....	3-50
3.13.1	PRINTING	3-50
	Registration - Leading Edge/Side-to-Side	3-50
	Blank Margin	3-51
	Main Scan Magnification	3-51
3.13.2	SCANNING	3-52
	Registration: Platen Mode	3-52
	Magnification	3-53
	Standard White Density Adjustment.....	3-54
3.13.3	ADF IMAGE ADJUSTMENT	3-55
	Registration and Blank Margin	3-55
	Sub-scan Magnification	3-55

TROUBLESHOOTING

4	TROUBLESHOOTING	4-1
4.1	SERVICE CALL CONDITIONS	4-1
4.1.1	SUMMARY	4-1
4.1.2	SC CODE DESCRIPTIONS.....	4-2
4.2	ELECTRICAL COMPONENT DEFECTS	4-8
4.2.1	SENSORS.....	4-8
4.2.2	SWITCHES	4-9
4.3	BLOWN FUSE CONDITIONS	4-10
4.4	LED DISPLAY	4-10
4.4.1	BICU.....	4-10
4.4.2	IOB.....	4-10
4.5	FIRMWARE MODIFICATION HISTORY.....	4-11

SERVICE TABLES

5	SERVICE TABLES	5-1
----------	-----------------------------	------------

5.1 USING SERVICE PROGRAM MODES	5-1
Accessing SP Modes	5-1
Accessing Copy Mode from within an SP Mode	5-1
How to Select a Program Number	5-2
To Input a Value or Setting for an SP Mode	5-2
5.1.1 SP MODE TABLES	5-3
SP1-XXX (Feed)	5-3
SP2-XXX (Drum).....	5-6
SP4-XXX (Scanner)	5-11
SP5-XXX (Mode)	5-17
SP6-XXX (Peripherals)	5-24
SP7-XXX (Data Log).....	5-26
5.1.2 TEST PATTERN PRINTING (SP5-902)	5-31
5.1.3 INPUT CHECK (SP5-803)	5-32
5.1.4 OUTPUT CHECK (SP5-804)	5-36
Output Check Table	5-36
5.1.5 COPY JAM HISTORY (SP7-903)	5-37
5.1.6 SMC PRINTING (SP5-992)	5-38
5.1.7 ORIGINAL JAM HISTORY DISPLAY (SP7-905)	5-38
5.1.8 MEMORY ALL CLEAR (SP5-801)	5-39
Using a Flash Memory Card	5-39
Without Using a Flash Memory Card	5-40
5.1.9 PROGRAM UPLOAD/DOWNLOAD	5-41
Program Download (SP5-827)	5-41
Program Upload (SP5-826)	5-42
5.1.10 NVRAM DATA UPLOAD/DOWNLOAD	5-43
NVRAM Data Download (SP5-825)	5-43
NVRAM Data Upload (SP5-824).....	5-44
5.1.11 APS AND PLATEN/ADF COVER SENSOR OUTPUT DISPLAY (SP4-301)	5-45
5.1.12 ADF APS SENSOR OUTPUT DISPLAY (SP6-901)	5-46
5.1.13 SERIAL NUMBER INPUT (SP5-811)	5-47
5.1.14 ID SENSOR ERROR ANALYSIS (SP2-221)	5-48
5.2 USER TOOLS	5-49
5.2.1 HOW TO ENTER AND EXIT USER TOOLS	5-49
5.2.2 USER TOOLS TABLE	5-49
System Setting Table.....	5-49
Copy Features Table	5-50

DETAILED SECTION DESCRIPTIONS

6 DETAILED SECTION DESCRIPTIONS	6-1
6.1 OVERVIEW	6-1
6.1.1 COMPONENT LAYOUT	6-1
6.1.2 PAPER PATH.....	6-3
6.1.3 DRIVE LAYOUT	6-4
6.2 BOARD STRUCTURE.....	6-5
6.2.1 BLOCK DIAGRAM.....	6-5

1. BiCU (Base Engine and Image Control Unit)	6-6
2. IOB (I/O Board)	6-6
3. SBU (Sensor Board Unit)	6-6
4. IMB (IMAC and Memory Board)	6-6
6.3 COPY PROCESS OVERVIEW	6-7
6.4 SCANNING	6-9
6.4.1 OVERVIEW	6-9
Lamp Stabilizer Fuse	6-9
6.4.2 SCANNER DRIVE	6-10
6.4.3 ORIGINAL SIZE DETECTION IN PLATEN MODE	6-11
6.5 IMAGE PROCESSING	6-13
6.5.1 OVERVIEW	6-13
6.5.2 SBU (SENSOR BOARD UNIT)	6-14
6.5.3 AUTO IMAGE DENSITY (ADS)	6-15
In the SBU	6-15
In the IPU	6-15
By Original Type	6-15
6.5.4 IPU (IMAGE PROCESSING UNIT)	6-16
Overview	6-16
Image Processing Modes	6-17
Image Processing Path	6-18
Original Modes	6-19
SP Modes for Each Image Processing Step	6-19
Auto Shading	6-21
White Line Erase	6-22
Black Line Erase	6-22
Scanner Gamma (γ) Correction	6-23
Main Scan Magnification	6-24
Mirroring for ADF Mode	6-24
Filtering	6-25
ID Gamma (γ) Correction	6-26
Gradation Processing	6-27
6.5.5 IMB (MEMORY CONTROLLER AND DRAM)	6-28
6.5.6 VIDEO CONTROL UNIT (VCU)	6-29
Fine Character and Image (FCI)	6-29
Printer Gamma Correction	6-29
6.6 LASER EXPOSURE	6-30
6.6.1 OVERVIEW	6-30
6.6.2 AUTO POWER CONTROL (APC)	6-31
6.6.3 LD SAFETY SWITCH	6-32
6.7 PHOTOCONDUCTOR UNIT (PCU)	6-33
6.7.1 OVERVIEW	6-33
6.7.2 DRIVE	6-34
6.8 DRUM CHARGE	6-35
6.8.1 OVERVIEW	6-35
6.8.2 CHARGE ROLLER VOLTAGE CORRECTION	6-36
Correction for Environmental Conditions	6-36
6.8.3 ID SENSOR PATTERN PRODUCTION TIMING	6-37
6.8.4 DRUM CHARGE ROLLER CLEANING	6-38

6.9 DEVELOPMENT	6-39
6.9.1 OVERVIEW	6-39
6.9.2 DRIVE.....	6-40
6.9.3 DEVELOPER MIXING	6-40
6.9.4 DEVELOPMENT BIAS	6-41
6.9.5 TONER SUPPLY	6-42
Toner Bottle Replenishment Mechanism	6-42
Toner Supply Mechanism	6-43
6.9.6 TONER DENSITY CONTROL	6-44
Overview.....	6-44
Toner Density Sensor Initial Setting.....	6-46
Toner Concentration Measurement	6-46
Vsp/Vsg Detection	6-46
Toner Supply Reference Voltage (Vref) Determination.....	6-46
Toner Supply Determination	6-46
Toner Supply Motor On Time Determinations.....	6-47
6.9.7 TONER SUPPLY IN ABNORMAL SENSOR CONDITIONS.....	6-48
ID Sensor.....	6-48
TD Sensor.....	6-48
6.9.8 TONER NEAR END/END DETECTION AND RECOVERY.....	6-49
Toner Near End Detection	6-49
Toner Near End Recovery	6-49
Toner End Detection	6-49
Toner End Recovery	6-49
6.10 DRUM CLEANING AND TONER RECYCLING.....	6-50
6.10.1 DRUM CLEANING.....	6-50
6.10.2 TONER RECYCLING	6-50
6.11 PAPER FEED.....	6-51
6.11.1 OVERVIEW	6-51
6.11.2 PAPER FEED DRIVE MECHANISM	6-52
6.11.3 PAPER FEED AND SEPARATION MECHANISM.....	6-52
6.11.4 PAPER LIFT MECHANISM	6-53
6.11.5 PAPER END DETECTION	6-53
6.11.6 PAPER SIZE DETECTION.....	6-54
Paper Tray.....	6-54
By-pass Tray.....	6-55
6.11.7 SIDE FENCES.....	6-56
6.11.8 PAPER REGISTRATION.....	6-56
6.12 IMAGE TRANSFER AND PAPER SEPARATION	6-57
6.12.1 OVERVIEW	6-57
6.12.2 IMAGE TRANSFER CURRENT TIMING	6-58
6.12.3 TRANSFER ROLLER CLEANING.....	6-59
6.12.4 PAPER SEPARATION MECHANISM.....	6-59
6.13 IMAGE FUSING AND PAPER EXIT	6-60
6.13.1 OVERVIEW	6-60
6.13.2 FUSING DRIVE AND RELEASE MECHANISM	6-60
6.13.3 FUSING ENTRANCE GUIDE SHIFT.....	6-61
6.13.4 PRESSURE ROLLER.....	6-61
6.13.5 FUSING TEMPERATURE CONTROL.....	6-62

Overview	6-62
Fusing Lamp Control	6-64
Fusing Temperature Control for Thick Paper at the By-pass Tray	6-65
Pre-heat Mode (Fusing Idling)	6-65
To Prevent Offset when Making Multiple Copies on Small-width Paper	6-65
Reduced Copy Speed with Narrow Paper	6-65
6.13.6 OVERHEAT PROTECTION	6-66
6.14 DUPLEX UNIT	6-67
6.14.1 OVERALL	6-67
6.14.2 DRIVE MECHANISM	6-68
6.14.3 BASIC OPERATION	6-69
Larger than A4 Short-edge/LT Short-edge	6-69
Up to A4 Short-edge/LT Short-edge	6-70
6.14.4 FEED IN AND EXIT MECHANISM	6-71
6.15 ENERGY SAVER MODES	6-72
6.15.1 OVERVIEW	6-72
6.15.2 LOW POWER MODE	6-73
Entering Low Power Mode	6-73
What Happens in Low Power Mode	6-73
Returning to Stand-by Mode	6-74
6.15.3 NIGHT/OFF MODE	6-74
Entering Night/Off Mode	6-74
What Happens in Night/Off Mode	6-75
Returning to Stand-by Mode	6-75

AUTO REVERSE DOCUMENT FEEDER B379

1 OVERALL MACHINE INFORMATION	7-1
1.1 MECHANICAL COMPONENT LAYOUT	7-1
1.2 ELECTRICAL COMPONENT LAYOUT	7-2
1.3 DRIVE LAYOUT	7-3
2 DETAILED SECTION DESCRIPTIONS	7-4
2.1 ORIGINAL SIZE DETECTION	7-4
2.2 PICK-UP AND SEPARATION	7-6
2.3 ORIGINAL TRANSPORT AND EXIT	7-7
2.3.1 SINGLE-SIDED ORIGINALS	7-7
2.3.2 DOUBLE-SIDED ORIGINALS	7-8
2.3.3 ORIGINAL TRAILING EDGE SENSOR	7-9
2.4 STAMP	7-10
2.5 TIMING CHARTS	7-11
2.5.1 SINGLE-SIDED ORIGINAL MODE (A3)	7-11
2.5.2 SINGLE-SIDED ORIGINAL MODE (A3, STAMP MODE)	7-12
2.5.3 DOUBLE-SIDED ORIGINAL MODE	7-13
2.5.4 DOUBLE-SIDED ORIGINAL MODE (STAMP MODE)	7-14
2.6 JAM DETECTION	7-15

2.7	OVERALL ELECTRICAL CIRCUIT	7-16
2.8	FREE RUN	7-17
	Procedure	7-17
	One-sided Free Run Process	7-17
	Two-sided Free Run Process	7-17
3	REPLACEMENT AND ADJUSTMENT.....	7-18
3.1	DF EXIT TABLE AND COVER	7-18
3.2	ORIGINAL FEED UNIT	7-19
3.3	LEFT COVER.....	7-20
3.4	PICK-UP ROLLER.....	7-21
3.5	FEED BELT	7-22
3.6	SEPARATION ROLLER.....	7-23
3.7	ORIGINAL SET/ORIGINAL REVERSE SENSORS.....	7-24
3.8	ORIGINAL L/W SENSOR, TRAILING EDGE SENSOR	7-25
3.9	FEED CLUTCH, PICK-UP SOL, TRANSPORT MOTOR, FEED MOTOR.....	7-26
	Exterior	7-26
	DF Feed Clutch.....	7-26
	Pick-up Solenoid.....	7-26
	Transport Motor	7-26
	DF Feed Motor.....	7-26
3.10	REGISTRATION SENSOR.....	7-27
3.11	STAMP SOLENOID AND ORIGINAL EXIT SENSOR	7-28

DOCUMENT FEEDER B387

1	OVERALL INFORMATION	8-1
1.1	MECHANICAL COMPONENT LAYOUT	8-1
1.2	ELECTRICAL COMPONENT LAYOUT	8-2
1.3	DRIVE LAYOUT	8-3
2	DETAILED SECTION DESCRIPTIONS	8-4
2.1	ORIGINAL SIZE DETECTION.....	8-4
2.2	PICK-UP AND SEPARATION	8-6
2.3	ORIGINAL TRANSPORT AND EXIT MECHANISM.....	8-7
2.4	STAMP	8-8
2.5	TIMING CHARTS	8-9
	2.5.1 A3.....	8-9
	2.5.2 A3, STAMP MODE	8-10
2.6	JAM DETECTION.....	8-11
2.7	OVERALL ELECTRICAL CIRCUIT	8-12
2.8	FREE RUN	8-13
	Procedure	8-13
	Free Run Process.....	8-13

3	REPLACEMENT AND ADJUSTMENT.....	8-14
3.1	EXTERIOR COVERS.....	8-14
3.1.1	REAR COVER.....	8-14
3.1.2	ORIGINAL TABLE.....	8-14
3.1.3	FRONT COVER.....	8-14
3.1.4	ORIGINAL ENTRANCE GUIDE.....	8-14
3.1.5	DF FEED COVER.....	8-15
3.2	FEED UNIT.....	8-15
3.3	SEPARATION ROLLER.....	8-15
3.4	PICK-UP ROLLER.....	8-16
3.5	FEED BELT.....	8-16
3.6	ORIGINAL SENSORS (WIDTH, LENGTH, TRAILING EDGE).....	8-17
3.7	ORIGINAL SET SENSOR.....	8-18
3.8	TRANSPORT MOTOR.....	8-18
3.9	DF COVER OPEN SENSOR/FEED CLUTCH/ROM/ DF DRIVE BOARD.....	8-19
	Exterior.....	8-19
	Feed Cover Open Sensor.....	8-19
	Feed Clutch.....	8-19
	ROM.....	8-19
	DF Drive Board.....	8-19
3.10	REGISTRATION SENSOR.....	8-21
3.11	PICK-UP SOLENOID.....	8-21
3.12	STAMP SOLENOID.....	8-22

PAPER TRAY UNIT B384

1	OVERALL MACHINE INFORMATION.....	9-1
1.1	MECHANICAL COMPONENT LAYOUT.....	9-1
1.2	ELECTRICAL COMPONENT LAYOUT.....	9-2
1.3	DRIVE LAYOUT.....	9-3
2	DETAILED DESCRIPTIONS.....	9-4
2.1	PAPER FEED AND SEPARATION MECHANISM.....	9-4
2.2	PAPER LIFT MECHANISM.....	9-5
2.3	PAPER END DETECTION.....	9-7
2.4	PAPER HEIGHT DETECTION.....	9-8
	PAPER SIZE DETECTION.....	9-9
2.5	SIDE AND END FENCES.....	9-10
	Side Fences.....	9-10
	End Fence.....	9-10
3	REPLACEMENT AND ADJUSTMENT.....	9-11
3.1	FEED ROLLER REPLACEMENT.....	9-11
3.2	TRAY MAIN BOARD REPLACEMENT.....	9-12
3.3	TRAY MOTOR REPLACEMENT.....	9-12

3.4 RELAY CLUTCH REPLACEMENT	9-13
3.5 UPPER PAPER FEED CLUTCH REPLACEMENT	9-14
3.6 LOWER PAPER FEED CLUTCH REPLACEMENT	9-15
3.7 LIFT MOTOR REPLACEMENT	9-16
3.8 PAPER END SENSOR REPLACEMENT	9-17
3.9 VERTICAL TRANSPORT SENSOR REPLACEMENT	9-17
3.10 PAPER SIZE SWITCH REPLACEMENT	9-18

PAPER TRAY UNIT B385

1 OVERALL MACHINE INFORMATION	10-1
1.1 MECHANICAL COMPONENT LAYOUT	10-1
1.2 ELECTRICAL COMPONENT LAYOUT	10-2
1.3 DRIVE LAYOUT	10-3
2 DETAILED DESCRIPTIONS	10-4
2.1 PAPER FEED AND SEPARATION	10-4
2.2 PAPER LIFT MECHANISM	10-5
2.3 PAPER END DETECTION	10-7
2.4 PAPER HEIGHT DETECTION	10-8
2.5 PAPER SIZE DETECTION	10-9
2.6 SIDE AND END FENCES	10-10
Side Fences	10-10
End Fence	10-10
3 REPLACEMENT AND ADJUSTMENT	10-11
3.1 FEED ROLLER REPLACEMENT	10-11
3.2 TRAY MAIN BOARD REPLACEMENT	10-12
3.3 TRAY MOTOR REPLACEMENT	10-13
3.4 LIFT MOTOR REPLACEMENT	10-14
3.5 PAPER END SENSOR REPLACEMENT	10-15
3.6 PAPER SIZE SWITCH REPLACEMENT	10-15

SPECIFICATIONS

SPECIFICATIONS	11-1
1. GENERAL SPECIFICATIONS	11 -1
Duplex Unit (B043 only)	11 -4
2. MACHINE CONFIGURATION	11 -5
3. OPTIONAL EQUIPMENT	11 -6
ARDF	11 -6
ADF	11 -7
ONE-TRAY PAPER TRAY UNIT	11 -8
TWO-TRAY PAPER TRAY UNIT	11 -9
16MB IMB (Copier Memory Unit)*	11 -9

B120 (RLA ONLY)

B120 (RLA ONLY)

12.1	INSTALLATION	12-1
12.2	PREVENTIVE MAINTENANCE SCHEDULES	12 -1
12.3	REPLACEMENT AND ADJUSTMENT	12 -1
12.4	TROUBLESHOOTING.....	12 -1
12.5	SERVICE TABLES	12 -1
12.5.1	SP MODE TABLES.....	12-1
12.5.2	COPY FEATURES TABLE (USER TOOLS).....	12-2
System Setting Table	12-2	
Copy Features Table.....	12-2	
12.6	DETAILED SECTION DESCRIPTIONS.....	12 -3
12.7	SPECIFICATIONS	12 -3

B404

TABLE OF CONTENTS

INSTALLATION

1	INSTALLATION.....	1-1
1.1	INSTALLATION REQUIREMENTS	1-1
1.1.1	ENVIRONMENT	1-1
1.1.2	MACHINE LEVEL	1-1
1.1.3	MINIMUM SPACE REQUIREMENTS.....	1-1
1.1.4	POWER REQUIREMENTS	1-1
1.2	FAX UNIT	1-2
1.2.1	ACCESSORY CHECK.....	1-2
1.2.2	INSTALLATION PROCEDURE	1-3
1.3	HANDSET	1-7
1.3.1	ACCESSORY CHECK.....	1-7
1.3.2	INSTALLATION PROCEDURE	1-7

PREVENTIVE MAINTENANCE

2	PREVENTIVE MAINTENANCE.....	2-1
2.1	SPECIAL TOOLS AND LUBRICANTS	2-1
2.2	PM TABLE.....	2-1

REMOVAL AND REPLACEMENT

3	REMOVAL AND REPLACEMENT	3-1
3.1	PRECAUTION.....	3-1
3.2	FCU	3-1
3.3	NCU.....	3-2
3.4	SPEAKER.....	3-3

TROUBLESHOOTING

4	TROUBLESHOOTING	4-1
4.1	ERROR CODES.....	4-1
4.2	FAX SC CODES.....	4-9
4.2.1	OVERVIEW	4-9
4.2.2	SC1201.....	4-9
4.2.3	FAX SC CODE TABLE	4-10
4.3	FAX OPTION FIRMWARE MODIFICATION HISTORY.....	4-11

SERVICE TABLES

5 SERVICE TABLES	5-1
5.1 SERVICE LEVEL FUNCTIONS	5-1
5.1.1 HOW TO ENTER AND EXIT SERVICE MODE	5-1
5.1.2 FUNCTION NO.	5-1
(1) 01. BIT SW	5-1
(2) 02. PARAMETER LIST	5-2
(3) 03. ERROR CODE	5-2
(4) 04. SERVICE REPORT	5-2
(5) 05. PROTOCOL DUMP	5-3
(6) 06. MEMORY.....	5-3
(7) 07. RAM CLEAR.....	5-4
(8) 08. NCU	5-4
(9) 09. ROM VERSION	5-5
(10) 10. FILE PRINTOUT	5-5
(11) 11. JOURNAL (ALL)	5-5
(12) 12. RAM TEST.....	5-6
(13) 13. S.S. NUMBER	5-6
(14) 14. SERIAL #	5-6
(15) 15. HISTORY	5-7
5.2 DATA TRANSFER.....	5-8
5.2.1 FAX SOFTWARE DOWNLOAD.....	5-8
5.2.2 FAX SRAM DOWNLOAD	5-9
5.2.3 FAX SRAM UPLOAD.....	5-10
5.3 BIT SWITCHES	5-11
5.3.1 SYSTEM SWITCHES	5-11
5.3.2 SCANNER SWITCHES	5-22
5.3.3 PLOTTER SWITCHES	5-27
5.3.4 COMMUNICATION SWITCHES	5-32
5.3.5 G3 SWITCHES	5-37
5.4 NCU PARAMETERS	5-45
5.5 DEDICATED TRANSMISSION PARAMETERS	5-56
5.5.1 PROGRAMMING PROCEDURE	5-56
5.5.2 PARAMETERS	5-57
5.6 SERVICE RAM ADDRESSES	5-60

DETAILED SECTION DESCRIPTIONS

6 DETAILED SECTION DESCRIPTIONS	6-1
6.1 OPERATION DUMP LIST.....	6-1
6.2 PCBS.....	6-2
6.2.1 FCU	6-2
6.2.2 NCU (US).....	6-4
6.2.3 NCU (EUROPE/ASIA)	6-5

SPECIFICATIONS

SPECIFICATIONS	7-1
1. GENERAL SPECIFICATIONS.....	7-1
2. FEATURES	7-2
2.1 FEATURES LIST	7-2
2.2 CAPABILITIES OF PROGRAMMABLE ITEMS	7-5
3. OVERALL MACHINE CONTROL	7-6
3.1 SYSTEM CONTROL	7-6
3.2 POWER DISTRIBUTION.....	7-6
3.3 MEMORY BACK-UP.....	7-6
4. VIDEO DATA PATH	7-7
4.1 TRANSMISSION	7-7
Memory Transmission and Parallel Memory Transmission.....	7-8
Immediate Transmission.....	7-8
4.2 RECEPTION.....	7-9
5. MACHINE CONFIGURATION.....	7-10

FIRMWARE HISTORY

FIRMWARE HISTORY	8-1
1. FIRMWARE MODIFICATION HISTORY	8-1

IMPORTANT SAFETY NOTICES

PREVENTION OF PHYSICAL INJURY

1. Before disassembling or assembling parts of the copier and peripherals, make sure that the power cord is unplugged.
2. The wall outlet should be near the copier and easily accessible.
3. Note that some components of the copier and the paper tray unit are supplied with electrical voltage even if the main power switch is turned off.
4. If a job has started before the copier completes the warm-up or initializing period, keep hands away from the mechanical and electrical components because the starts making copies as soon as the warm-up period is completed.
5. The inside and the metal parts of the fusing unit become extremely hot while the copier is operating. Be careful to avoid touching those components with your bare hands.

HEALTH SAFETY CONDITIONS

Toner and developer are non-toxic, but if you get either of them in your eyes by accident, it may cause temporary eye discomfort. Try to remove with eye drops or flush with water as first aid. If unsuccessful, get medical attention.

OBSERVANCE OF ELECTRICAL SAFETY STANDARDS

The copier and its peripherals must be installed and maintained by a customer service representative who has completed the training course on those models.

SAFETY AND ECOLOGICAL NOTES FOR DISPOSAL

1. Do not incinerate toner bottles or used toner. Toner dust may ignite suddenly when exposed to an open flame.
2. Dispose of used toner, developer, and organic photoconductors in accordance with local regulations. (These are non-toxic supplies.)
3. Dispose of replaced parts in accordance with local regulations.

LASER SAFETY

The Center for Devices and Radiological Health (CDRH) prohibits the repair of laser-based optical units in the field. The optical housing unit can only be repaired in a factory or at a location with the requisite equipment. The laser subsystem is replaceable in the field by a qualified Customer Engineer. The laser chassis is not repairable in the field. Customer engineers are therefore directed to return all chassis and laser subsystems to the factory or service depot when replacement of the optical subsystem is required.

WARNING

Use of controls, or adjustment, or performance of procedures other than those specified in this manual may result in hazardous radiation exposure.

WARNING FOR LASER UNIT





WARNING: Turn off the main switch before attempting any of the procedures in the Laser Unit section. Laser beams can seriously damage your eyes.

CAUTION MARKING:



Symbols and Abbreviations

This manual uses several symbols and abbreviations. The meaning of those symbols and abbreviations are as follows:

	See or Refer to
	Clip ring
	Screw
	Connector
SEF	Short Edge Feed
LEF	Long Edge Feed

INSTALLATION B039/B040/B043

PAPER TRAY UNIT B384

**TAB
POSITION 1**

PREVENTIVE MAINTENANCE B039/B040/B043

PAPER TRAY UNIT B385

**TAB
POSITION 2**

REPLACEMENT AND ADJUSTMENT B039/B040/B043

SPECIFICATIONS

**TAB
POSITION 3**

TROUBLESHOOTING B039/B040/B043

FAX UNIT B404

**TAB
POSITION 4**

SERVICE TABLES B039/B040/B043

B120 (RLA only)

**TAB
POSITION 5**

DETAILED SECTION DESCRIPTION B039/B040/B043

**TAB
POSITION 6**

AUTO REVERSE DOCUMENT FEEDER B379

**TAB
POSITION 7**

DOCUMENT FEEDER B387

**TAB
POSITION 8**

INSTALLATION

1. INSTALLATION

⚠ CAUTION

Before installing options, please do the following:

1. If there is a fax unit in the machine, print out all messages stored in the memory, the lists of user programmed items, and the system parameter list.
2. If there is a printer option in the machine, print out all data in the printer buffer.
3. Turn off the main switch and disconnect the power cord, the telephone line, and the network cable.

1.1 INSTALLATION REQUIREMENTS

1.1.1 ENVIRONMENT

-Temperature and Humidity Chart-

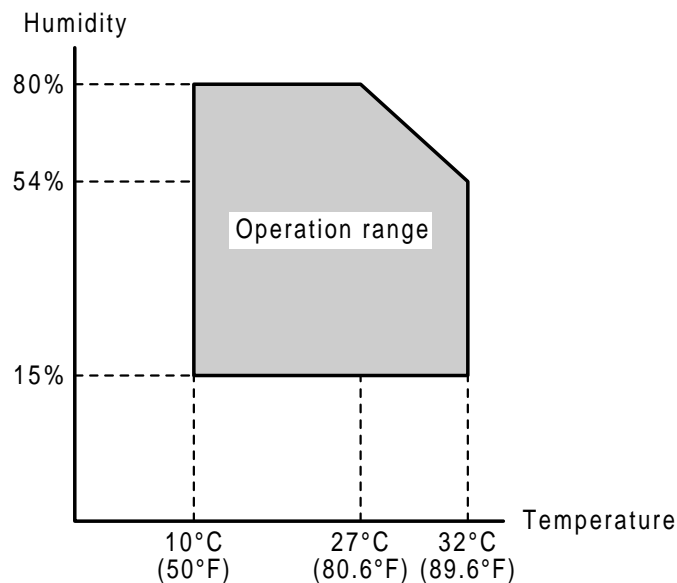

INSTALLATION REQUIREMENTS

1. Temperature Range: 10°C to 32°C (50°F to 89.6°F)
2. Humidity Range: 15% to 80% RH
3. Ambient Illumination: Less than 1,500 lux (do not expose to direct sunlight).
4. Ventilation: Room air should turn over at least 30 m³/hr/person
5. Ambient Dust: Less than 0.075 mg/m³ (2.0 x 10⁻⁶ oz/yd³)
6. Avoid areas exposed to sudden temperature changes:
 - 1) Areas directly exposed to cool air from an air conditioner.
 - 2) Areas directly exposed to heat from a heater.
7. Do not place the machine where it will be exposed to corrosive gases.
8. Do not install the machine at any location over 2,000 m (6,500 ft.) above sea level.
9. Place the copier on a strong and level base. (Inclination on any side should be no more than 5 mm.)
10. Do not place the machine where it may be subjected to strong vibrations.

1.1.2 MACHINE LEVEL

- Front to back: Within 5 mm (0.2") of level
Right to left: Within 5 mm (0.2") of level

1.1.3 MINIMUM SPACE REQUIREMENTS

Place the copier near the power source, providing clearance as shown:

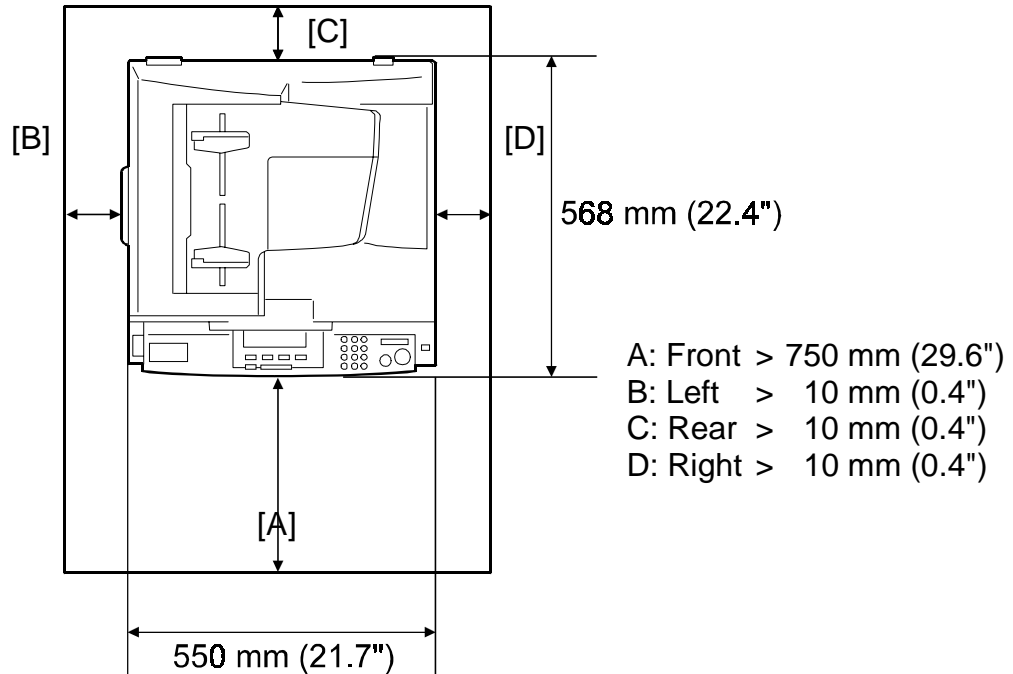

- NOTE:** 1) The recommended 750 mm front space is sufficient to allow the paper tray to be pulled out. Additional front space is required to allow operators to stand at the front of the machine.
- 2) The recommended 10 mm right space is for installation only. Additional right space is required to allow operators to fix paper jams and use the by-pass tray.

1.1.4 POWER REQUIREMENTS

<p>⚠ CAUTION</p> <ol style="list-style-type: none"> 1. Make sure that the wall outlet is near the copier and easily accessible. After completing installation, make sure the plug fits firmly into the outlet. 2. Avoid multi-wiring. 3. Be sure to ground the machine.
--

- Input voltage:
 America, Taiwan: 110 – 120 V, 50/60 Hz, 12 A
 Europe, Asia: 220 – 240 V, 50/60 Hz, 7 A

1.2 COPIER INSTALLATION

1.2.1 POWER SOCKETS FOR PERIPHERALS

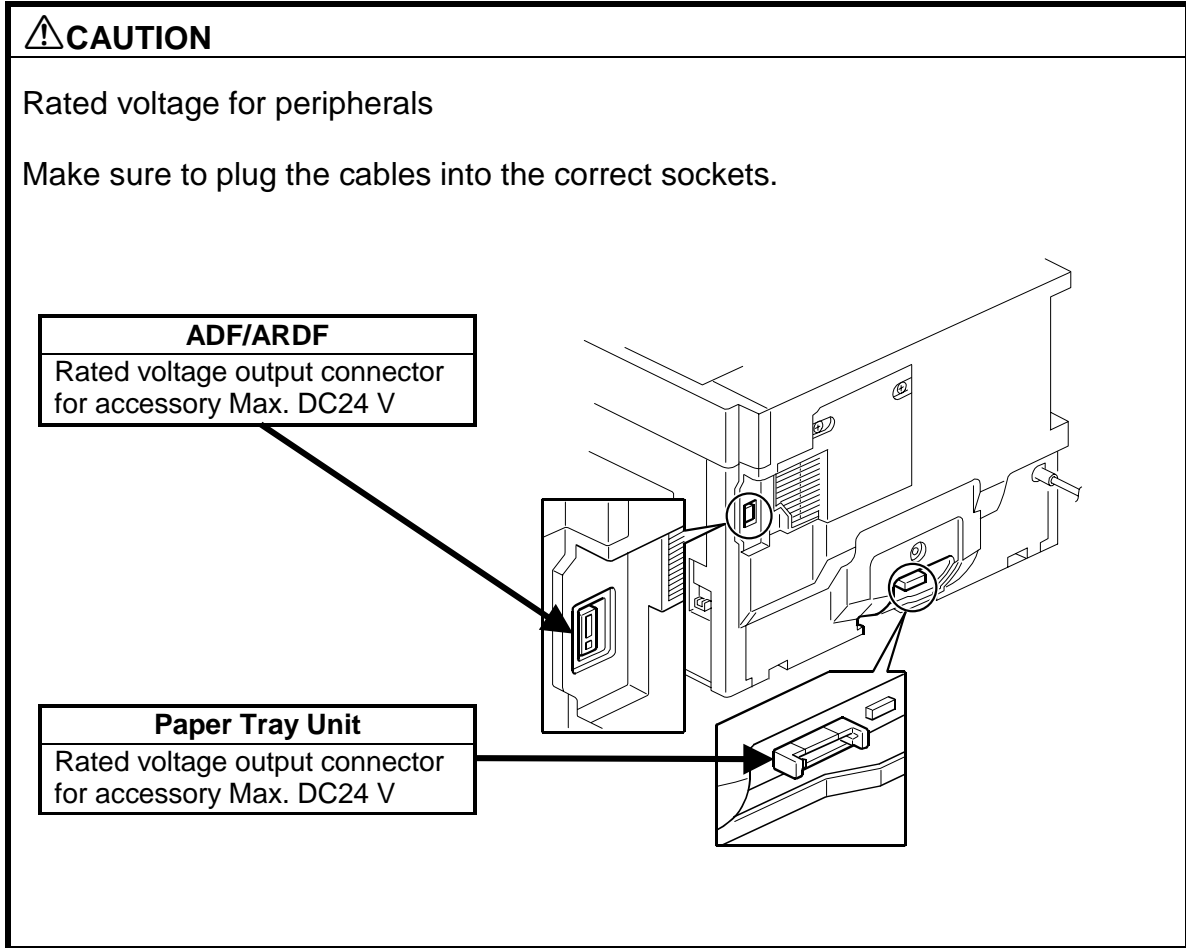

1.1.2 ACCESSORY CHECK

Check that you have the accessories indicated below.

No.	Description	Q'ty
1	Operation Instructions - System Settings	1
2	Operation Instructions - Copy Reference	1
3	New Equipment Condition Report (NECR) - English (-10, -17)	1
4	New Equipment Condition Report (NECR) - Multi Language (-19, -27, -29, -69)	1
5	Model Nameplate (-10, -17, -22)	1
6	Model Name Decal (-22)	1

1.1.3 INSTALLATION PROCEDURE

⚠ CAUTION
When installing the copier, make sure that the copier is unplugged.

1. Remove the strips of tape.

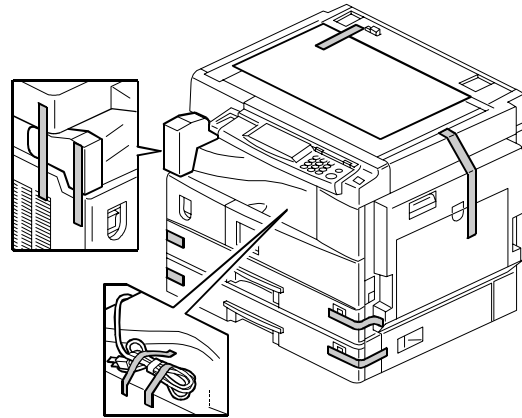

2. Open the front door and remove the toner bottle holder [A].

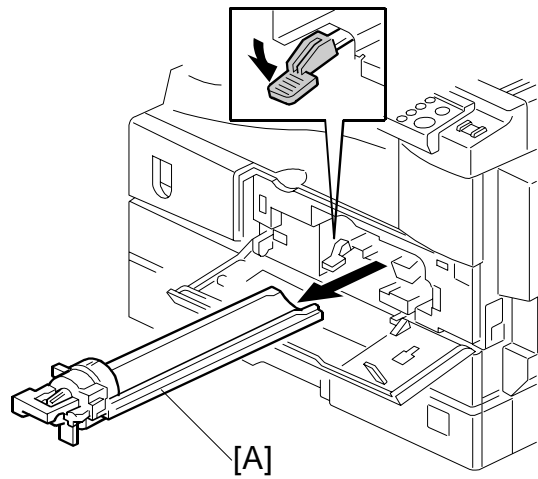

3. Open the right door, and remove the PCU (Photoconductor Unit) [B].

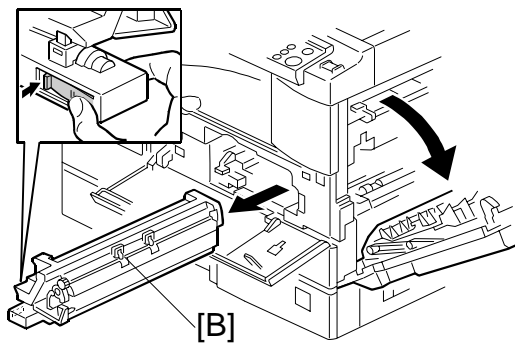

COPIER INSTALLATION

4. Separate the PCU into two sections as shown (5 screws).

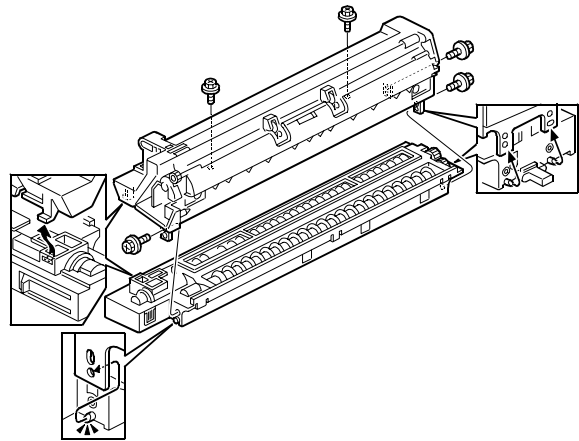

5. Distribute one pack of developer [A] evenly across the width of the development unit, into all openings.
NOTE: 1) To prevent foreign material from getting on the sleeve rollers, place a sheet of paper under the development unit.
2) Make sure not to spill the developer on the gears [B].
3) If it is necessary to turn the gear [B] to distribute the developer, make sure to do so very minimally, otherwise the developer may spill.

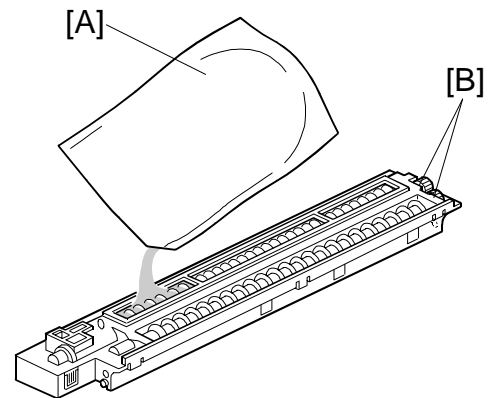

6. Reassemble and reinstall the PCU.
7. Shake the toner bottle [C] several times.
NOTE: Be sure not to remove the toner bottle cap [D] until after shaking.

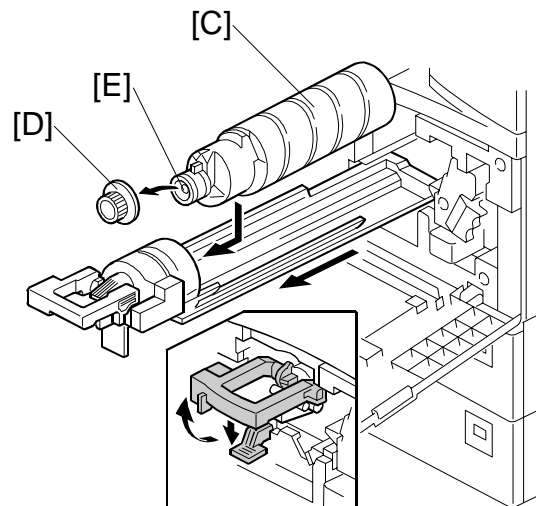

8. Unscrew the bottle cap [D] and insert the bottle into the holder.
NOTE: Do not touch the inner bottle cap [E].
9. Reposition the holder and press down the holder lever to secure the bottle.
10. Pull out the paper tray and turn the paper size dial to the appropriate size. Adjust the end and side guides to match the paper size.
NOTE: To move the side guides, first release the green lock on the rear side guide.

11. Install the optional ARDF, ADF, or platen cover (☛ 1.3/1.4/1.5).
12. Plug in the main power cord and turn on the main switch. Perform TD Sensor Initialization (SP2-214).
13. Select the correct display language using UP Mode (Language).
14. Load the paper in the paper tray and make a full size copy, and check if the side-to-side and leading edge registrations are correct. If they are not, adjust the registrations (☛ 3.13 Copy Adjustments: Printing/Scanning).
15. Initialize the electric total counter using SP7-825 in accordance with the type of service contract.
NOTE: Select 1, then press the Original Type and OK keys at the same time. If the reset is successful, “Action completed” will appear on the LCD.

PLATEN COVER INSTALLATION

1.3 PLATEN COVER INSTALLATION

1.3.1 ACCESSORY CHECK

Check that you have the accessories indicated below.

No.	Description	Q'ty
1	Stepped Screw	2

1.3.2 INSTALLATION PROCEDURE

⚠ CAUTION

Unplug the machine power cord before starting the following procedure.

1. Install the platen cover [A] (2 screws).

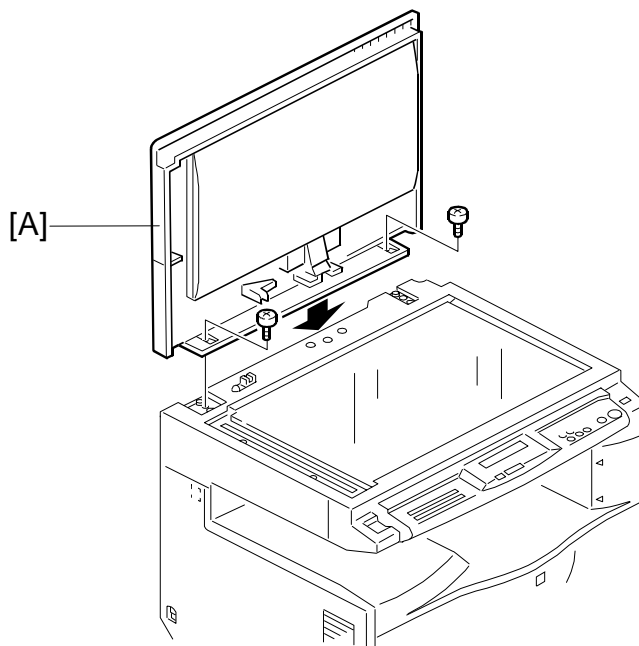

1.4 ARDF INSTALLATION

1.4.1 ACCESSORY CHECK

Check the quantity and condition of the accessories against the following list.

No.	Description	Q'ty
1	Scale Guide	1
2	DF Exposure Glass	1
3	Stud Screw	2
4	Knob Screw	2
5	Original Size Decal	2
6	Screwdriver Tool	1

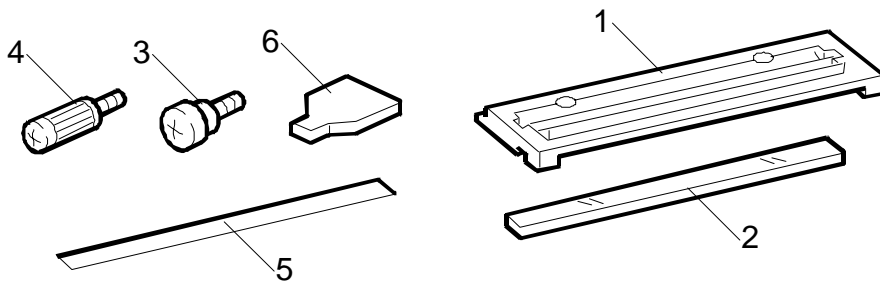

1.1.2 INSTALLATION PROCEDURE

1. Remove the strips of tape.

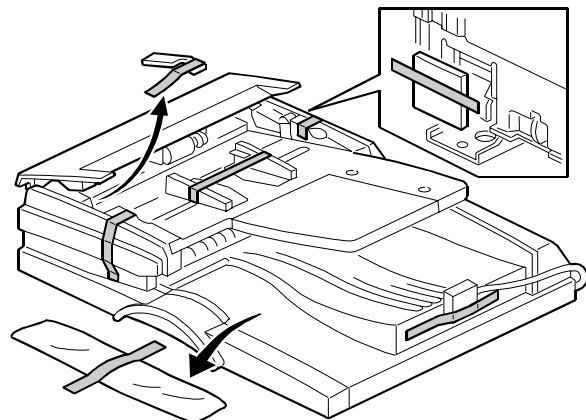

ARDF INSTALLATION

2. Remove the left scale [A] (2 screws).
3. Place the DF exposure glass [B] on the glass holder.
NOTE: When installing the DF exposure glass, make sure that the white point [C] is face down.
4. Peel off the backing [D] of the double-sided tape attached to the rear side of the scale guide [E], then install it (2 screws removed in step 2).
5. Install the two stud screws [F].
6. Mount the DF on the copier, then slide the DF to the front.
7. Secure the DF unit with two screws [G].
8. Connect the cable [H] to the copier.

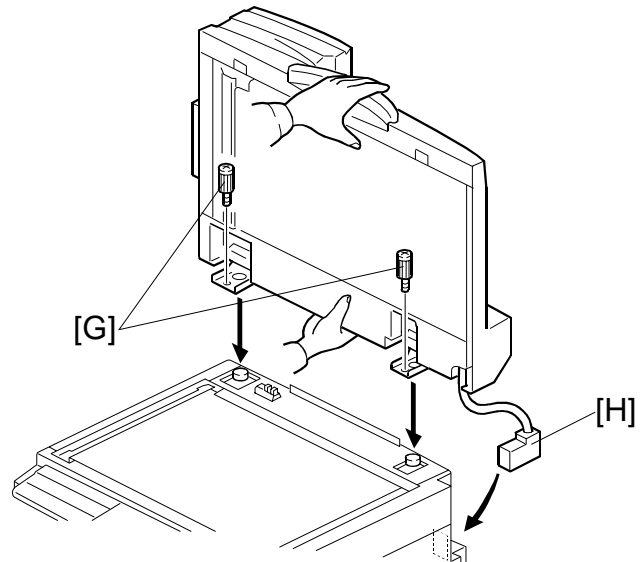
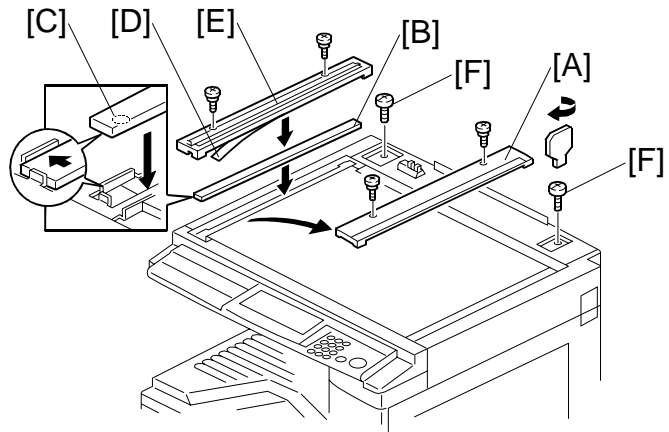

9. Attach the appropriate scale decal [I] as shown.
10. Turn the main power switch on. Then check if the document feeder works properly.
11. Make a full size copy, and check that the side-to-side and leading edge registrations are correct. If they are not, adjust the side-to-side and leading edge registrations. (☛ 3.13.3 ADF Image Adjustment)

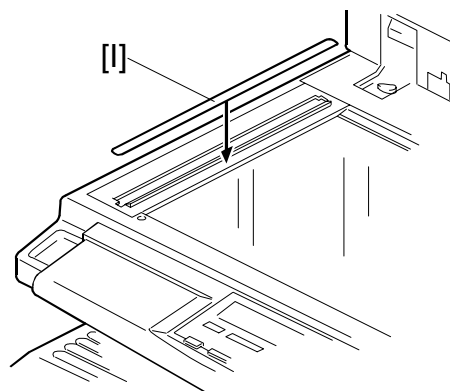

1.5 ADF INSTALLATION

1.5.1 ACCESSORY CHECK

Check the quantity and condition of the accessories against the following list.

No.	Description	Q'ty
1	Scale Guide	1
2	DF Exposure Glass	1
3	Stud Screw	2
4	Fixing Screw	2
5	Original Size Decal	2
6	Screwdriver Tool	1

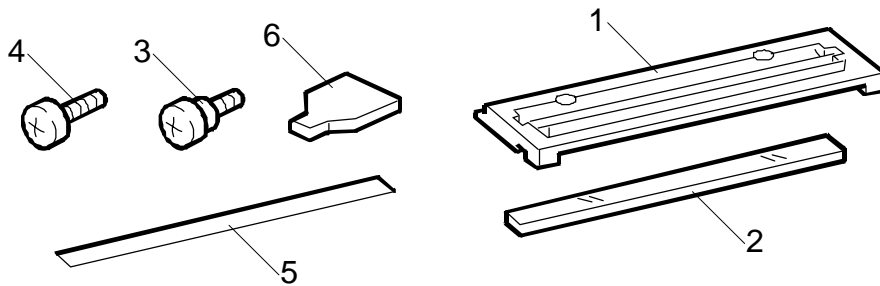

1.5.2 INSTALLATION PROCEDURE

1. Remove the strips of tape.

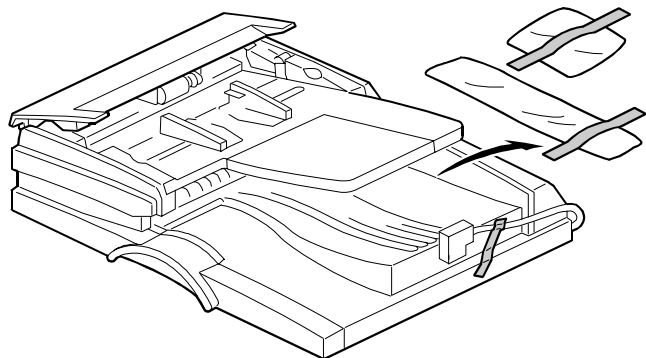

ADF INSTALLATION

- Remove the left scale [A] (2 screws).
- Place the DF exposure glass [B] on the glass holder.
NOTE: When installing the DF exposure glass, make sure that the white point [C] is face down.
- Peel off the backing [D] of the double-sided tape attached to the rear side of the scale guide [E], then install it (2 screws removed in step 2).
- Install the two stud screws [F].
- Mount the DF on the copier, then slide the DF to the front.
- Secure the DF unit with two screws [G].
- Connect the cable [H] to the copier.

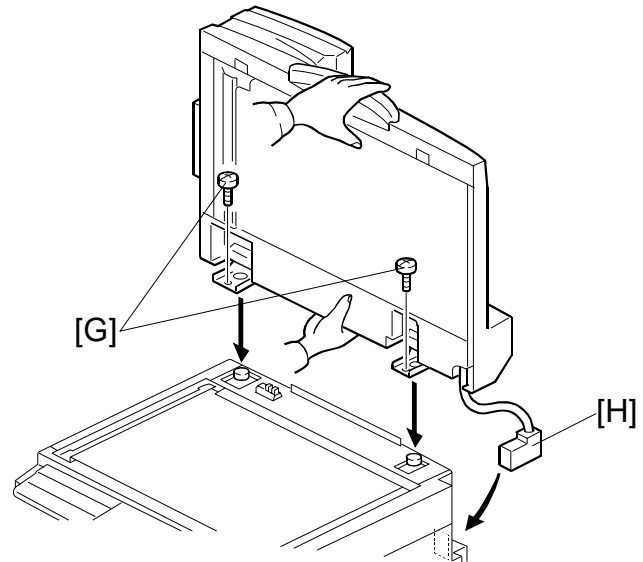
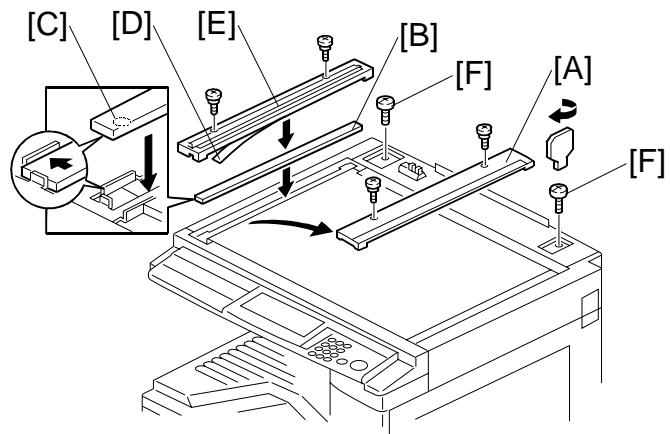

- Attach the appropriate scale decal [I] as shown.
- Turn the main power switch on. Then check if the document feeder works properly.
- Make a full size copy, and check that the side-to-side and leading edge registrations are correct. If they are not, adjust the side-to-side and leading edge registrations. (☛ 3.13.3 ADF Image Adjustment).

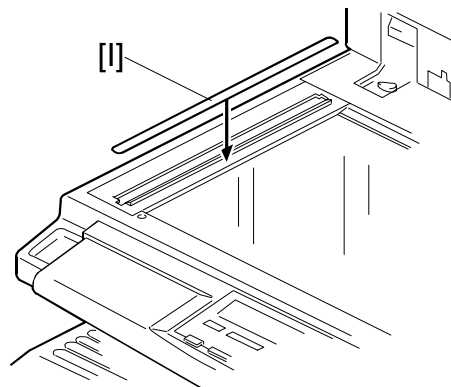

1.6 TWO-TRAY PAPER TRAY UNIT INSTALLATION

1.6.1 ACCESSORY CHECK

Check the quantity and condition of the accessories against the following list.

No.	Description	Q'ty
1	Screw – M4x10	10
2	Unit Holder	4
3	Adjuster	1
4	Unit Holder	2

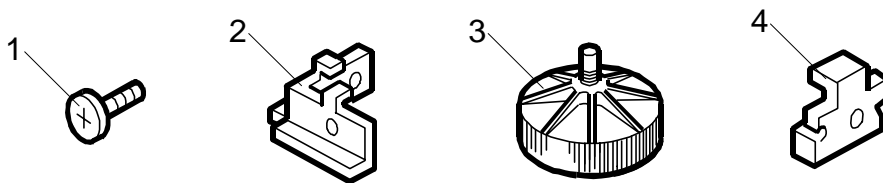

1.6.2 INSTALLATION PROCEDURE

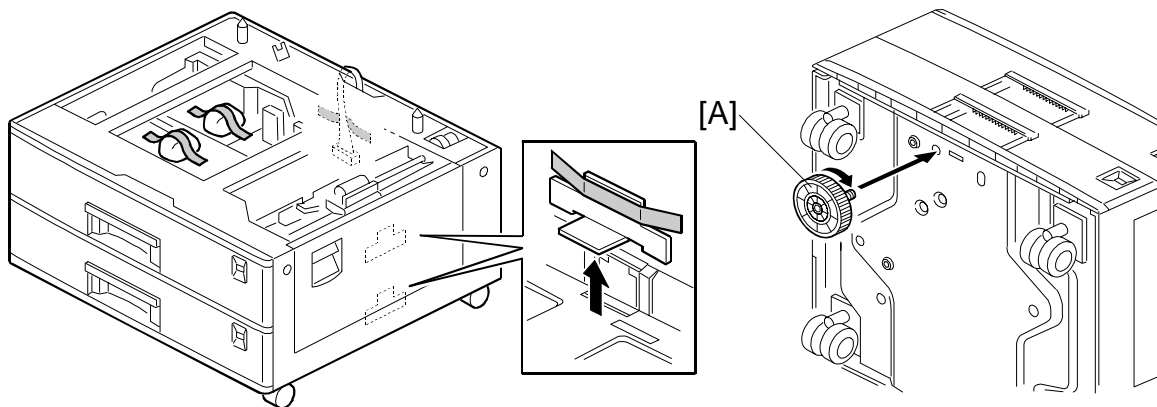

1. Remove the strips of tape.
NOTE: After removing the tape that secures the peripheral components and cardboard to the paper tray, make sure that there is no tape and/or tape residue remaining on the tray.
2. Attach the adjuster [A] to the base plate, as shown.
NOTE: If a table is installed, this step is unnecessary.

TWO-TRAY PAPER TRAY UNIT INSTALLATION

3. Remove the cover [A] (1 rivet).

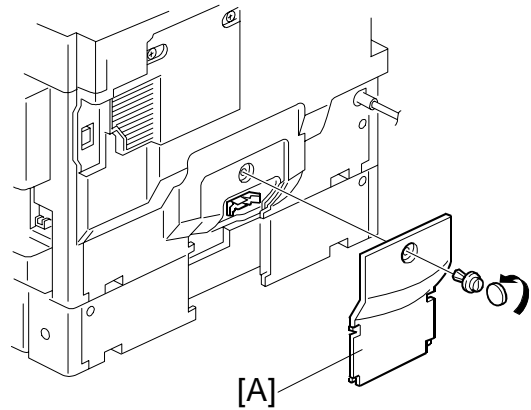

4. Set the copier on the paper tray unit.
NOTE: When installing the copier, be careful not to pinch the connecting harness.

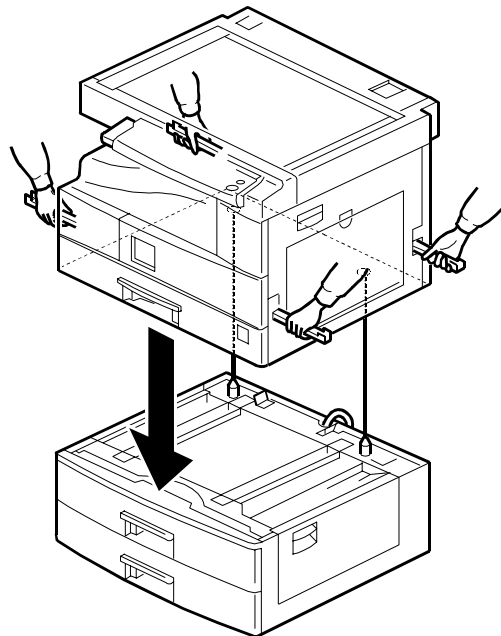

5. **One-tray copier model (B039):**
Remove the 1st tray cassette [B].

Two-tray copier models (B040/B043):
Remove the 2nd tray cassette [B].

6. Install the two screws [C].
7. Reinstall the tray cassette.

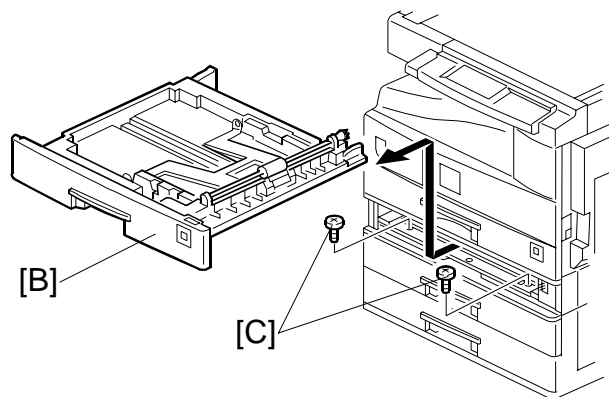

TWO-TRAY PAPER TRAY UNIT INSTALLATION

8. Install the two brackets [A] (1 stepped screw each).
9. Connect the connecting harness [B] to the copier.
NOTE: There are cutouts in the plug on both sides. The left side has one cutout, and the right side has two.
10. Reinstall the cover removed in step 3 (1 rivet).

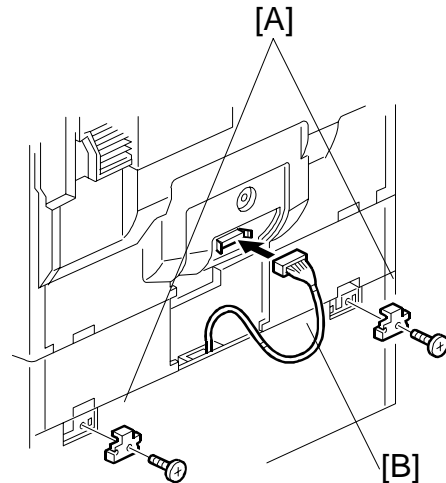

11. Install the four brackets [C] (2 screws each).
NOTE: If a table is installed, this step is unnecessary.

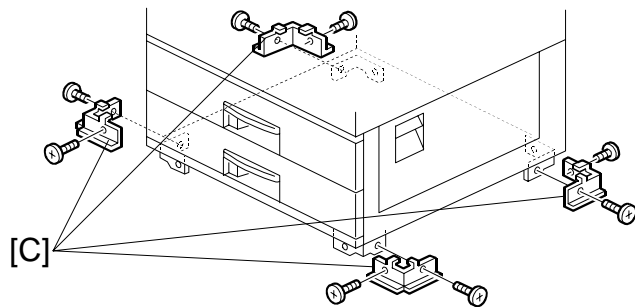

12. Rotate the adjuster [D] to fix the machine in place.
NOTE: If a table is installed, this step is unnecessary.

13. Load the paper in the paper trays and make full size copies from each tray. Check if the side-to-side and leading edge registrations are correct. If they are not, adjust the registrations (see 3.13 Copy Adjustments: Printing/ Scanning).

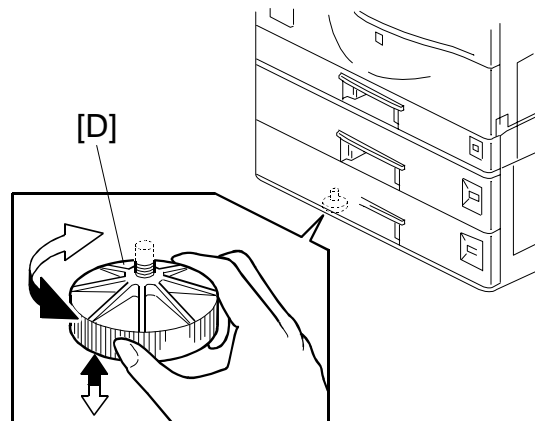

ONE-TRAY PAPER TRAY UNIT INSTALLATION

1.7 ONE-TRAY PAPER TRAY UNIT INSTALLATION

1.7.1 ACCESSORY CHECK

Check the quantity and condition of the accessories against the following list.

No.	Description	Q'ty
1	Screw – M4x10	2
2	Stepped Screw – M4x10	2
3	Unit Holder	2

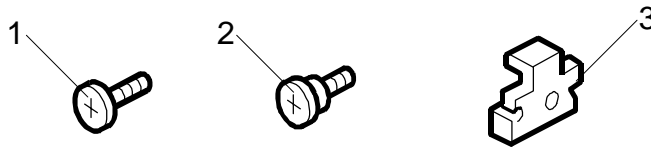

1.7.2 INSTALLATION PROCEDURE

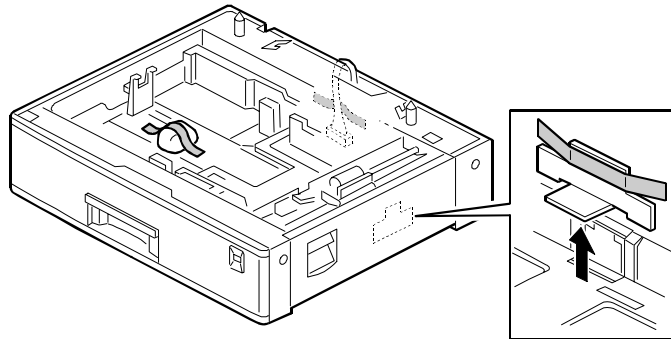

1. Remove the strips of tape.

NOTE: After removing the tape that secures the peripheral components and cardboard to the paper tray, make sure that there is no tape and/or tape residue remaining on the tray.

ONE-TRAY PAPER TRAY UNIT INSTALLATION

2. Remove the cover [A] (1 rivet).

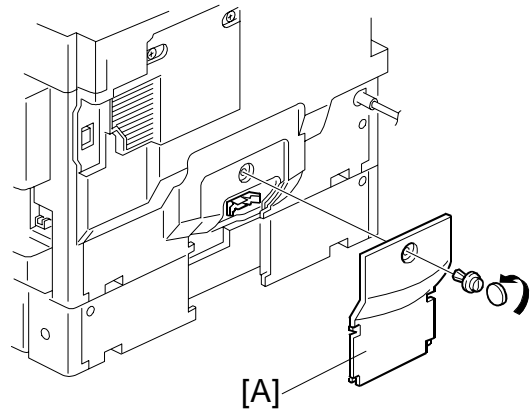

3. Set the copier on the paper tray unit.
NOTE: When installing the copier, be careful not to pinch the connecting harness.

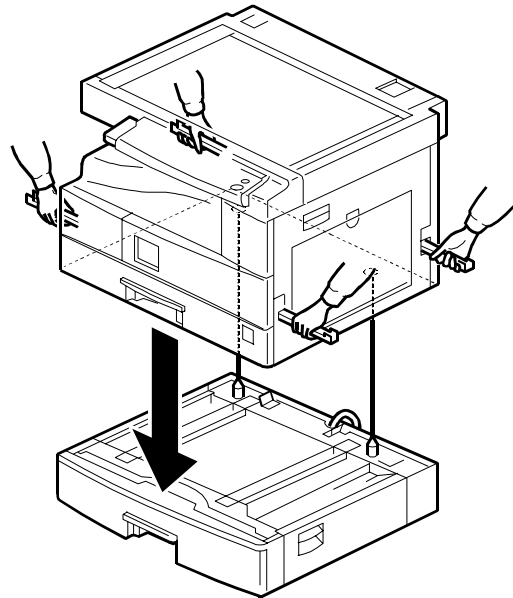

4. **One-tray copier model (B039):**
Remove the 1st tray cassette [B].
Two-tray copier models (B040/B043):
Remove the 2nd tray cassette [B].

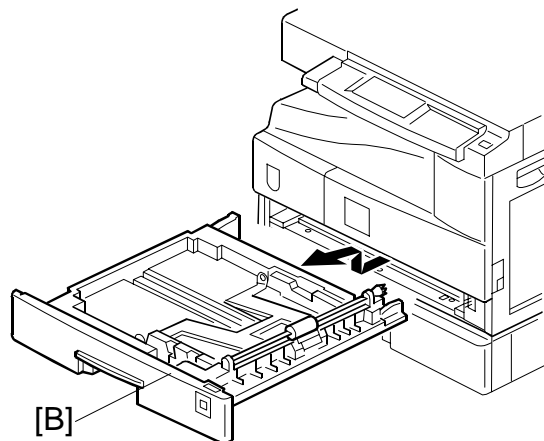

ONE-TRAY PAPER TRAY UNIT INSTALLATION

5. Install the two screws [A].
6. Reinstall the tray cassette.

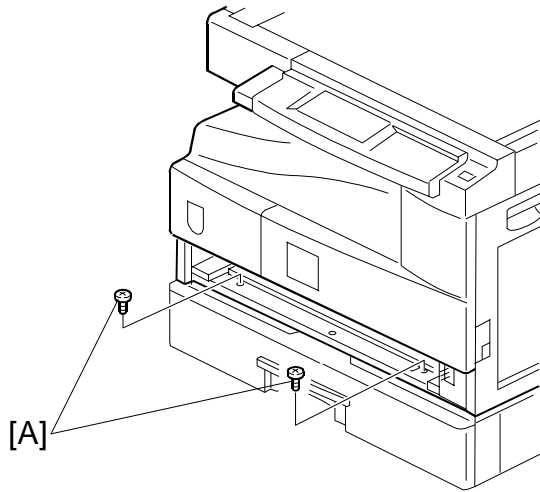

7. Install the two brackets [B]. (1 stepped screw each).
8. Connect the connecting harness [C] to the copier.
NOTE: There are cutouts in the plug on both sides. The left side has one cutout, and the right side has two.
9. Reinstall the cover removed in step 2.
10. Load the paper in the paper tray and make full size copies from tray. Check if the side-to-side and leading edge registrations are correct. If they are not, adjust the registrations (☛ 3.13 Copy Adjustments: Printing/Scanning).

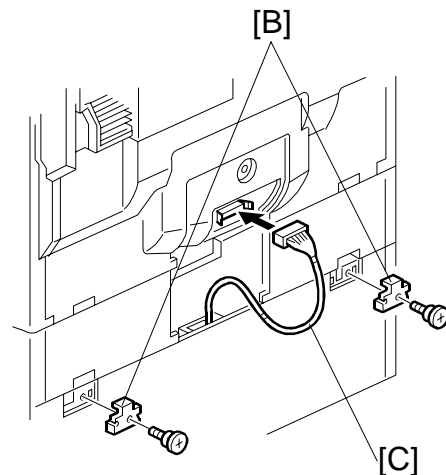

1.8 IMB INSTALLATION

1.8.1 ACCESSORY CHECK

Click the quantity and condition of the accessory against the following list:

No.	Description	Q'ty
1	Screw – M3x6	3

1.8.2 INSTALLATION PROCEDURE

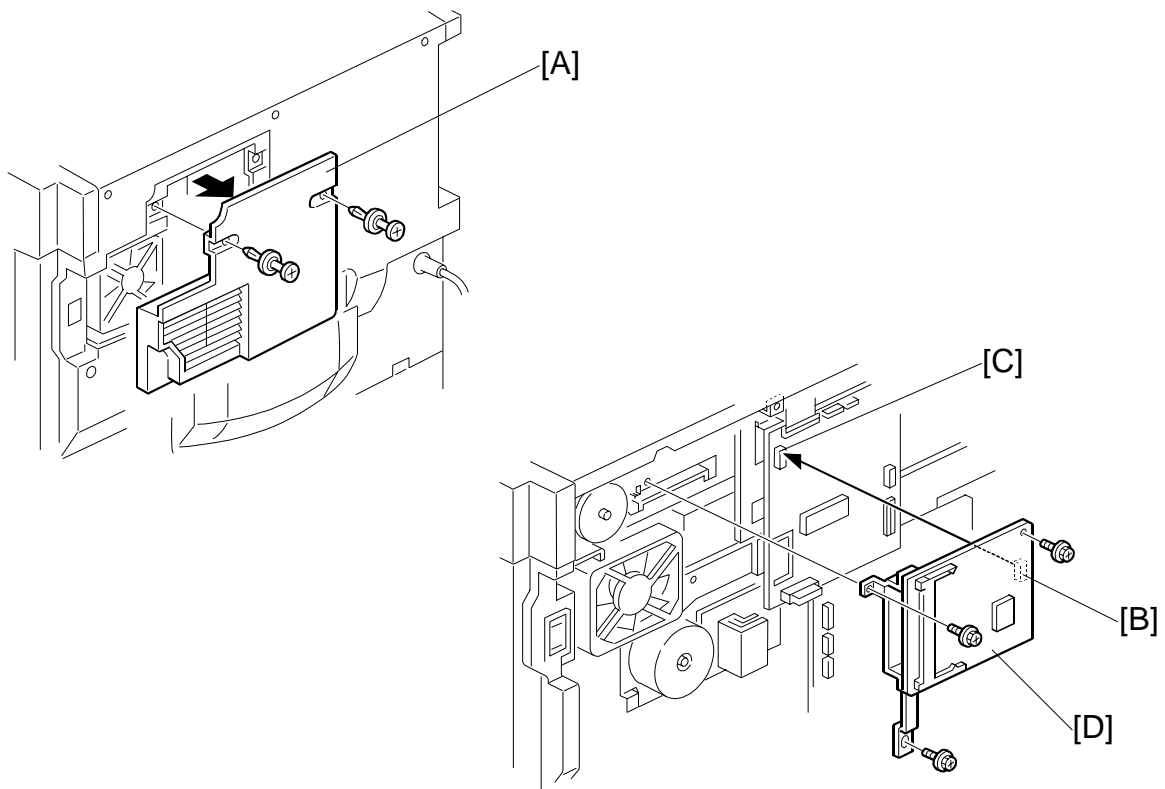

1. Remove the rear middle cover [A] (2 rivets).
2. Connect the connectors [B, C] and install the IMB [D] (3 screws).
3. Reinstall the rear middle cover.

1.9 DRAM INSTALLATION

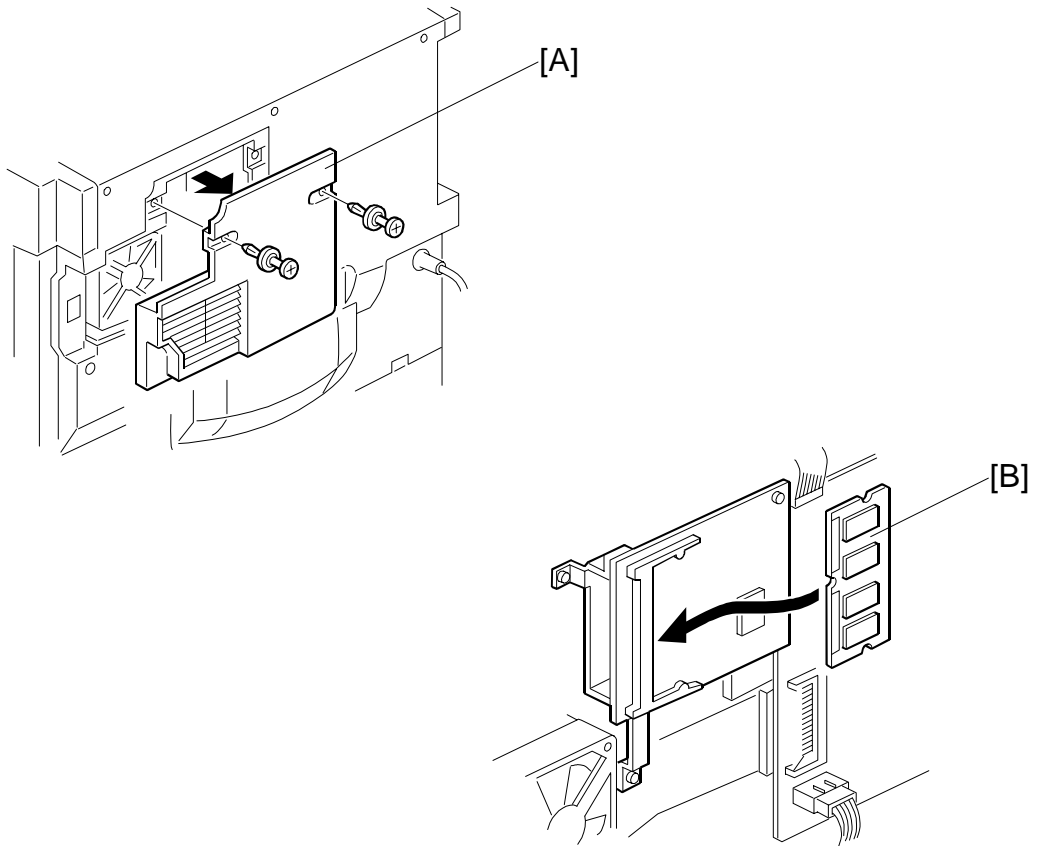

NOTE: The IMB must be installed before installing the DRAM.

1. Remove the rear middle cover [A] (2 rivets).
2. Install the DRAM [B].
3. Reinstall the rear middle cover.

1.10 ANTI-CONDENSATION HEATER INSTALLATION

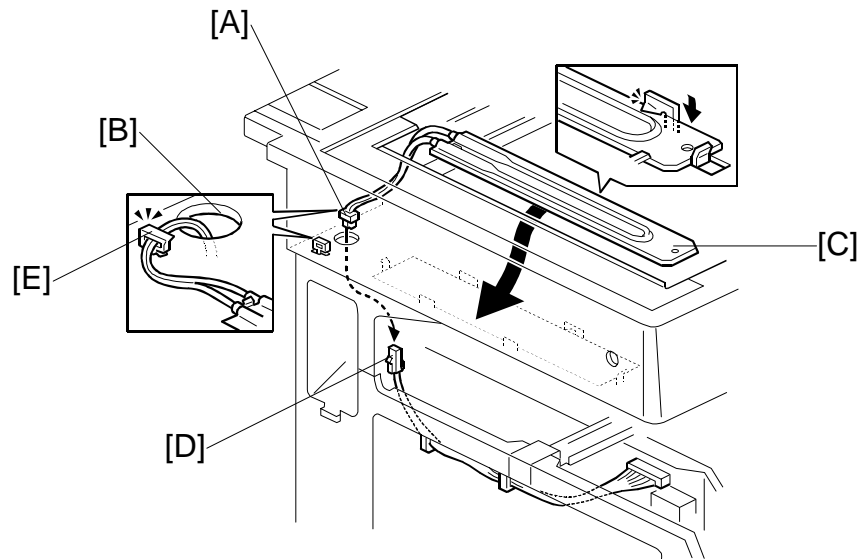

1. Remove the exposure glass (☛ 3.4.1).
2. Remove the left cover (☛ 3.3.8).
3. Pass the connector [A] through the opening [B].
4. Install the anti-condensation heater [C], as shown.
5. Join the connectors [A, D].
6. Clamp the harness with the clamp [E].
7. Reinstall the left cover and exposure glass.

1.11 TRAY HEATERS

1.11.1 UPPER TRAY HEATER

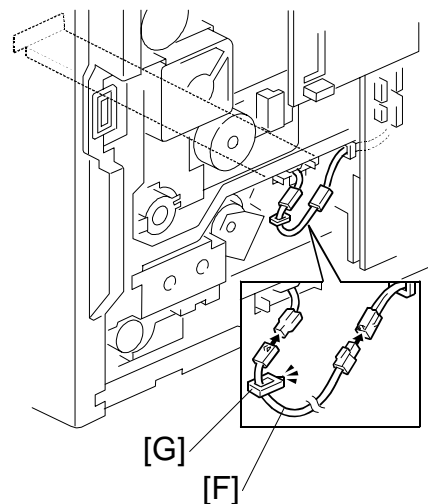
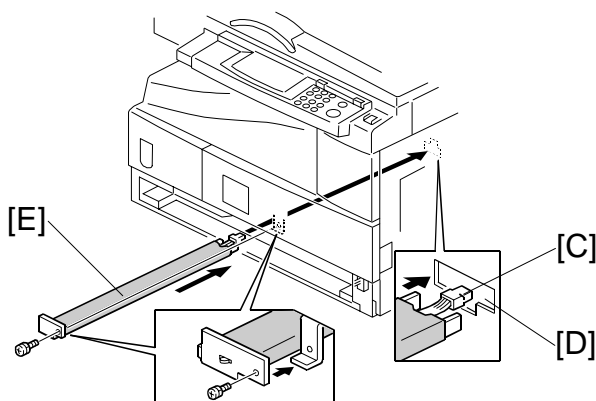
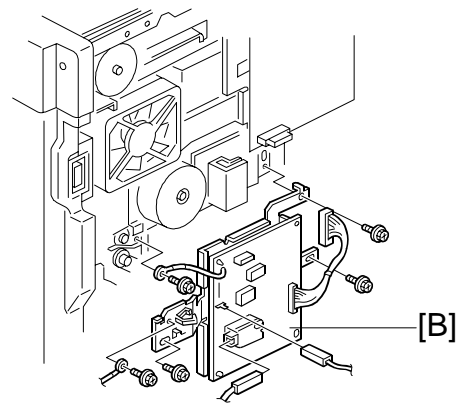
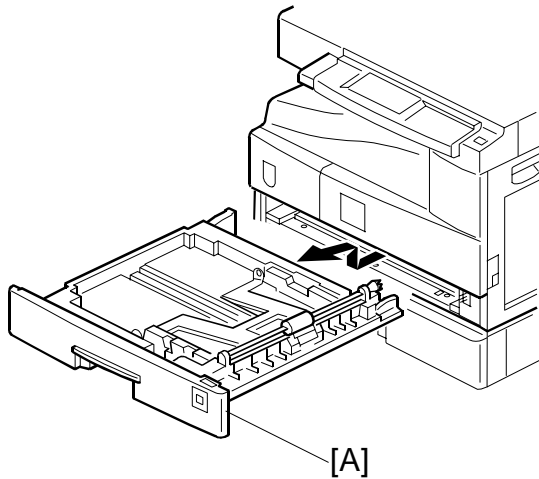

1. Remove the 1st tray cassette [A].
2. Remove the rear cover (☛ 3.3.1).
3. Remove the high voltage power supply board [B] with bracket (5 screws and 3 connectors).
4. Pass the connector [C] through the opening [D] and install the tray heater [E] (1 screw).
5. Install the relay cable [F], as shown.
6. Clamp the cable with the clamp [G].
7. Reinstall the 1st tray cassette, power pack, and rear cover.

1.11.2 LOWER TRAY HEATER (TWO-TRAY MODEL ONLY)

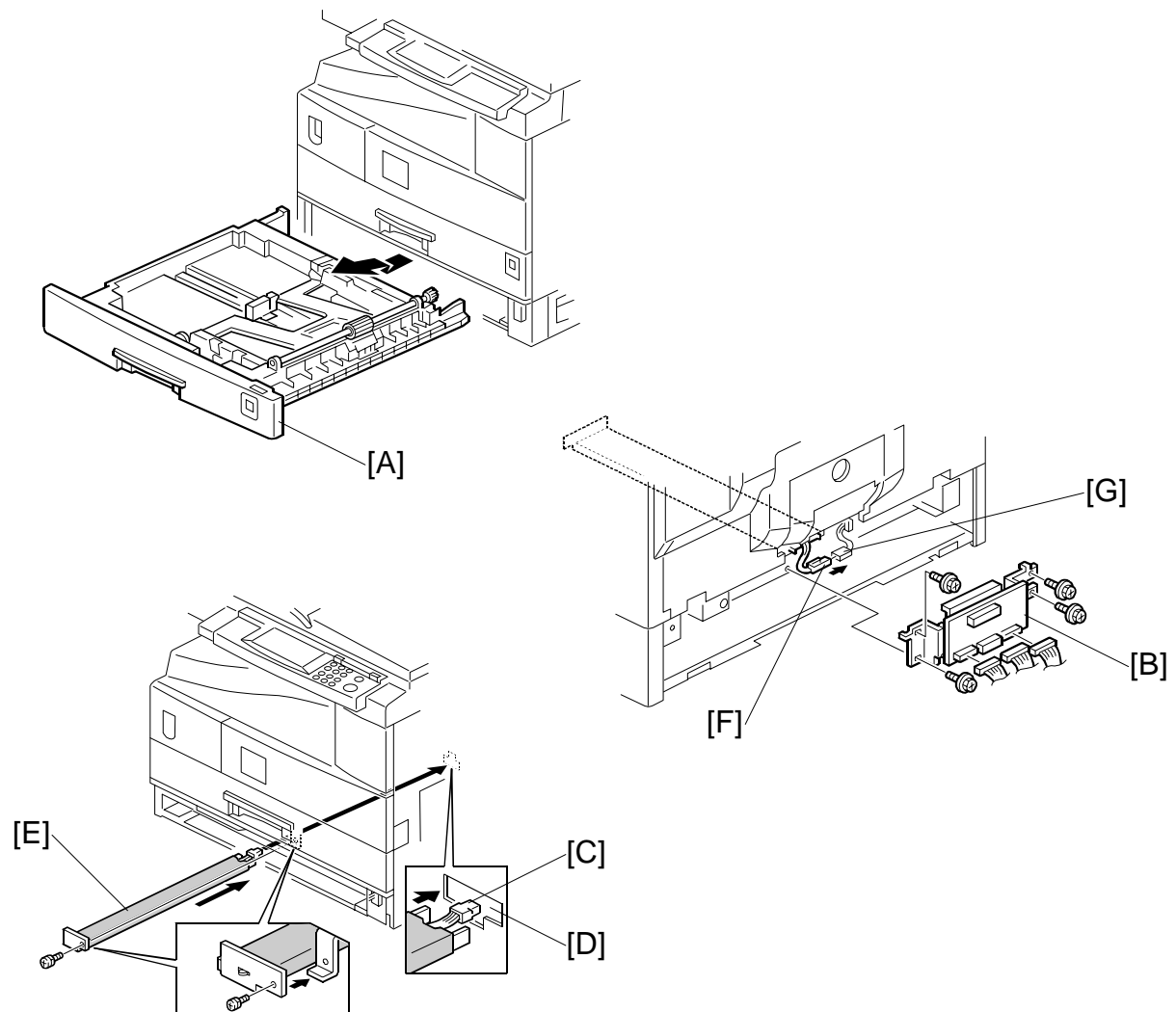

1. Remove the 2nd tray cassette [A].
2. Remove the rear lower cover (☛ 3.3.2).
3. **B043 model only:**
Remove the DCB [B] with bracket (4 screws and 3 connectors).
4. Pass the connector [C] through the opening [D] and install the tray heater [E] (1 screw).
5. Join the connectors [F, G].
6. Reinstall the 2nd tray cassette, DCB, and rear lower cover.

TRAY HEATERS

1.11.3 TRAY HEATERS FOR THE OPTIONAL PAPER FEED UNITS

1. Remove the rear cover for the paper tray unit [A] (2 screws).

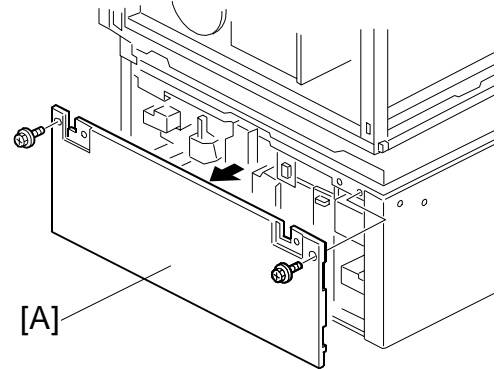

2. Two-tray unit only: Remove the cable guide [B] (1 screw).
3. Install the clamps [C].

- One-tray paper feed unit -

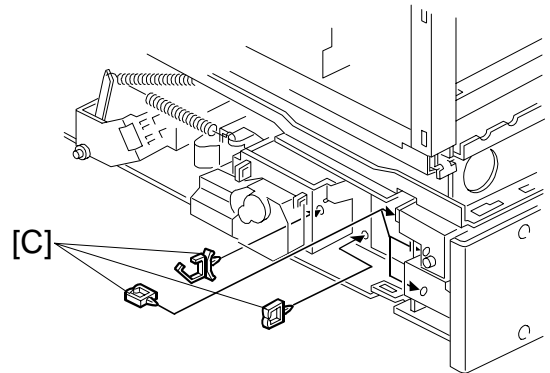

- Two-tray paper feed unit -

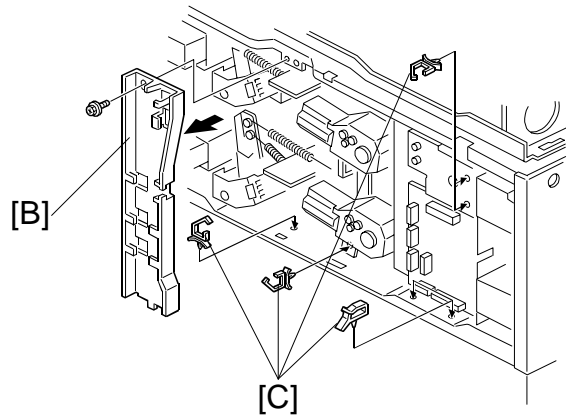

TRAY HEATERS

- One-tray paper feed unit -

4. Pass the connector [A] through the opening [B].
5. Install the tray heater [C] (1 screw).

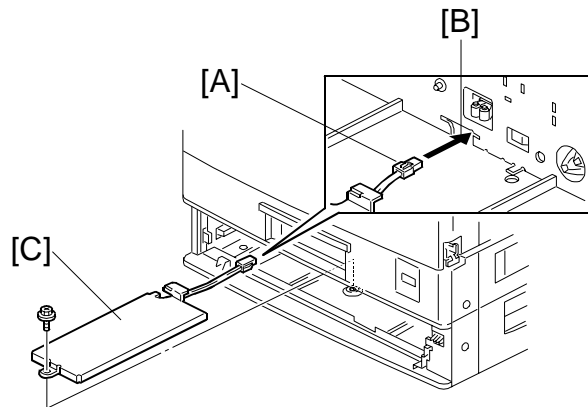

- Two-tray paper feed unit -

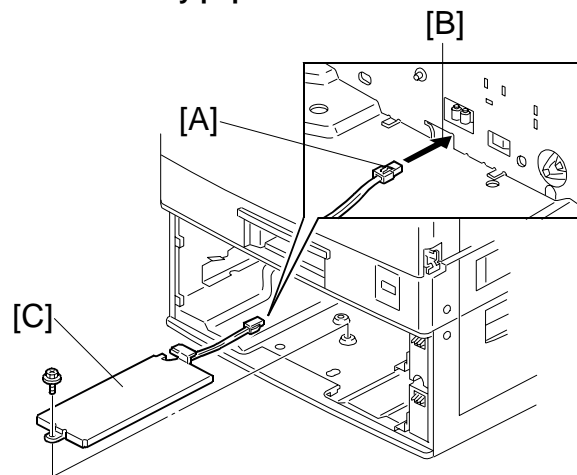

TRAY HEATERS

6. Clamp the cables [A], as shown.
7. Join the connectors [B].
8. Two-tray unit only: Reinstall the cable guide.
9. **One-tray copier model (B039):**
Remove the 1st tray cassette.
Two-tray copier models (B040/B043):
Remove the 2nd tray cassette.

- One-tray paper feed unit -

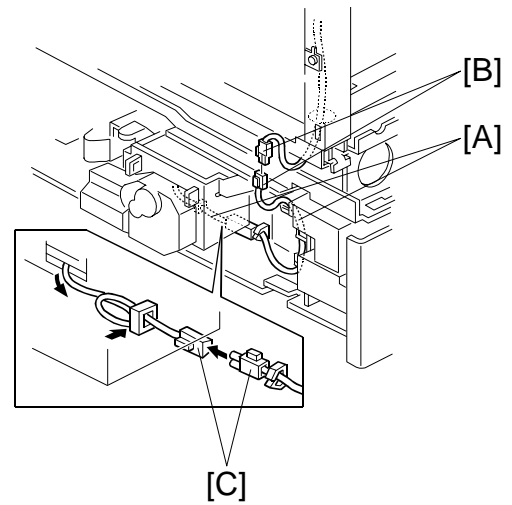

- Two-tray paper feed unit -

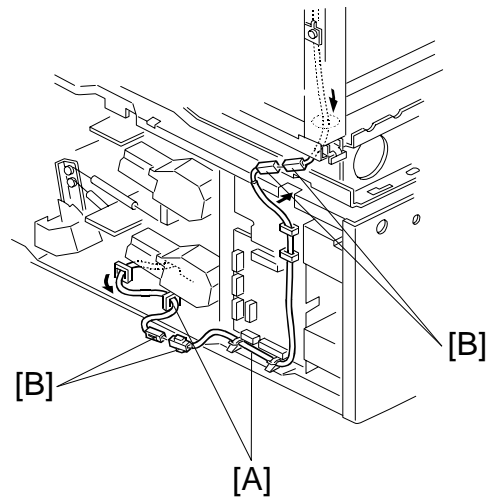

10. Remove the two screws [C] and install the two hexagonal socket screws [D].
11. Reinstall the 1st tray and rear cover.

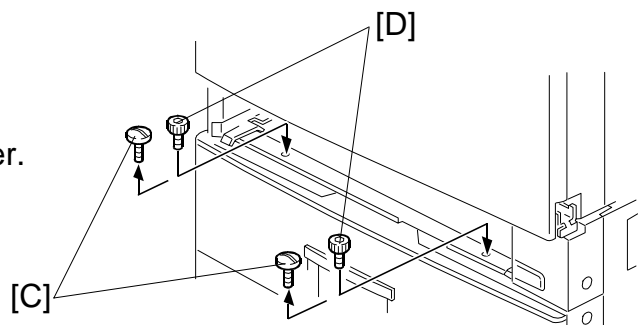

1.12 KEY COUNTER INSTALLATION

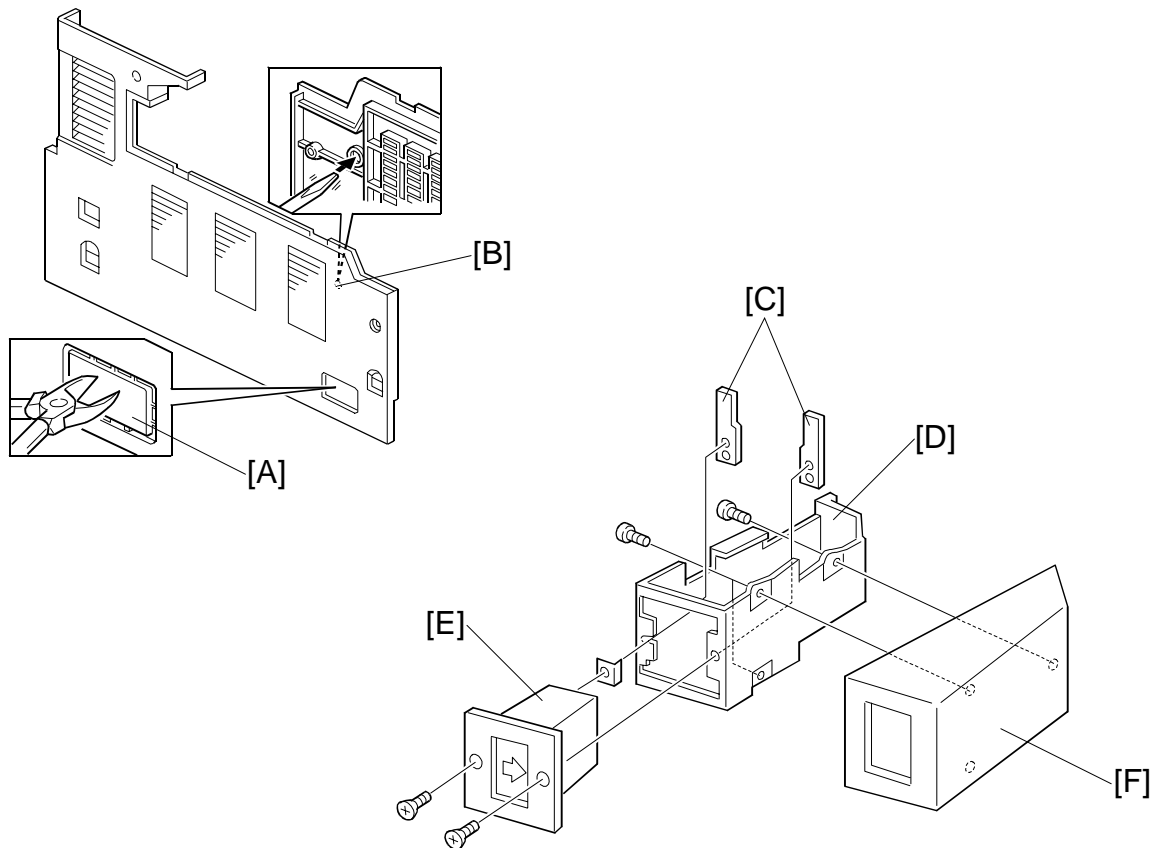

1. Remove the left cover (☛ 3.3.8).
2. Remove the rear cover (☛ 3.3.1).
3. Remove the cap [A] with nippers.
4. Punch out the small hole [B] using a screwdriver.
5. Hold the key counter plate nuts [C] on the inside of the key counter bracket [D] and insert the key counter holder [E].
6. Secure the key counter holder to the bracket (2 screws).
7. Install the key counter cover [F] (2 screws).

KEY COUNTER INSTALLATION

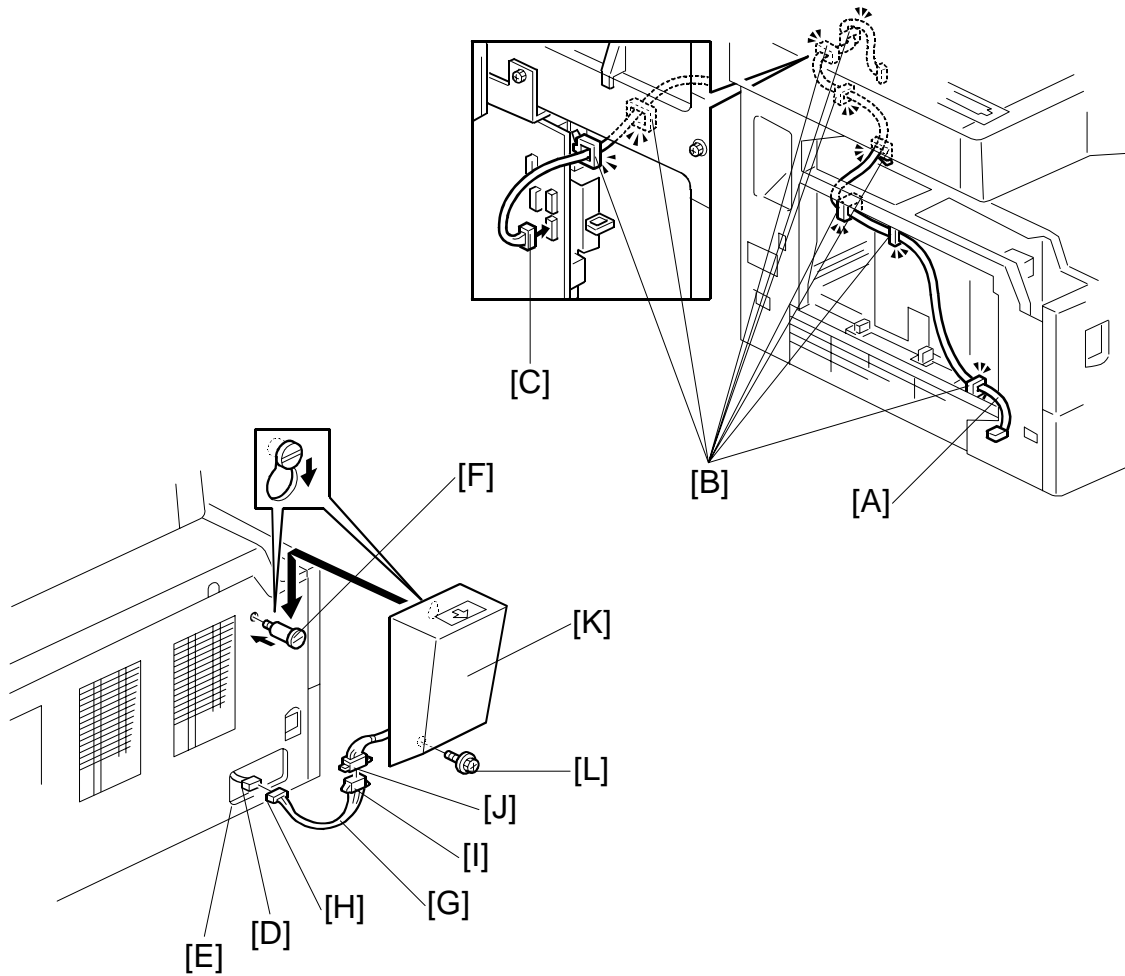

8. Clamp the relay cable [A] with the clamps [B], as shown.
NOTE: The relay cable [A] is not included in the key counter bracket accessories.
9. Connect the connector [C] to CN306 on the IOB.
10. Reinstall the rear and left cover.
NOTE: When reinstalling the left cover, pass the relay cable connector [D] through the opening [E].
11. Install the stepped screw [F].
12. Install the relay cable [G] and join the connectors [D, H].
13. Join the connectors [I, J].
14. Hook the key counter holder assembly [K] onto the stepped screw [F].
15. Secure the key counter holder assembly with a screw [L].
16. Change the value of SP5-113 to "1".

PREVENTIVE MAINTENANCE

2. PREVENTIVE MAINTENANCE SCHEDULES

2.1 PM TABLES

NOTE: 1) After carrying out PM, clear the PM counter (SP7-804).
2) PM intervals (60k, 80k, and 120K) indicate the number of prints.

Key: AN: As necessary C: Clean R: Replace L: Lubricate I: Inspect

	EM	60k	120k	AN	NOTE
OPTICS					
Reflector	C				Optics cloth
1st mirror	C			C	Optics cloth
2nd mirror	C			C	Optics cloth
3rd mirror	C			C	Optics cloth
Scanner guide rails	C				Do not use alcohol.
Platen cover	I			C	Replace the platen sheet, if necessary. Blower brush or alcohol
Exposure glass	C			C	Blower brush or alcohol
Toner shield glass	C				Blower brush
APS sensors	C				Blower brush
DRUM AREA					
PCU		I			
Drum		R			
Developer		R			
Charge roller		R			
Cleaning brush (for charge roller)		R			
Cleaning blade (for OPC drum)		R			
Separation pawls		R			
Transfer roller			R		
ID sensor	C			C	Blower brush
PAPER FEED					
Paper feed roller (in each feed tray)		C	R	C	Clean with water or alcohol.
Friction pad (in each feed tray)		C	R	C	Clean with water or alcohol.
Bottom-plate pad (in each feed tray)		C		C	Clean with water or alcohol.
Paper feed roller (bypass tray)		C		C	Clean with water or alcohol.
Friction pad (bypass tray)		C		C	Clean with water or alcohol.
Bottom-plate pad (by-pass tray)		C		C	Clean with water or alcohol.
Registration rollers		C		C	Clean with water or alcohol.
Relay rollers		C		C	Clean with water or alcohol.

PM TABLES

	EM	60k	120k	AN	NOTE
Paper feed guides		C		C	Clean with water or alcohol.
Paper-dust Mylar		C		C	Clean with water or alcohol.
FUSING UNIT					
Hot roller		R			
Pressure roller			R		
Hot roller bushings			I		
Pressure-roller bushing			R		
Hot roller stripper pawls			R	C	Dry cloth
Thermistor		C		C	Dry cloth

	80k	AN	NOTE
ADF, ARDF			
Feed belt	R	C	Clean with water or alcohol.
Separation roller	R	C	Clean with water or alcohol.
Pick-up roller	R	C	Clean with water or alcohol.
Stamp		R	Replace when necessary.
White plate		C	Clean with water or alcohol.
DF exposure glass		C	Clean with water or alcohol.
Platen cover		C	Clean with water or alcohol.

	60k	120k	AN	NOTE
PAPER TRAY UNIT (ONE-TRAY AND TWO-TRAY MODELS)				
Paper feed rollers		R	C	Dry or damp cloth
Bottom-plate pads	C		C	Dry cloth
Paper-feed guides	C		C	Clean with water or alcohol.
Friction pads		R	C	Dry or damp cloth
PAPER TRAY UNIT (TWO-TRAY MODEL ONLY)				
Relay clutch		I		
Feed clutch		I		
Relay roller		C	C	Dry cloth

2.2 HOW TO CLEAR THE PM COUNTER

After PM, clear the PM counter (SP7-804).

1. Access SP mode 7-804.
1. Press the *Original Type* key and the *OK* or  key at the same time to reset the counter. If the reset is successful, the display shows “Action completed.” If the reset fails, the display shows “Error!!!”

REPLACEMENT AND ADJUSTMENT

3. REPLACEMENT AND ADJUSTMENT

3.1 GENERAL CAUTIONS

Do not turn off the main switch while any of the electrical components are active. Doing so may result in damage to units (such as the PCU) as they are pulled out or replaced.

3.1.1 PCU (PHOTOCONDUCTOR UNIT)

The PCU consists of the OPC drum, charge roller, development unit, and cleaning components. Observe the following precautions when handling the PCU.

1. Never touch the drum surface with bare hands. If the drum surface is dirty or if you have accidentally touched it, wipe it with a dry cloth, or clean it with wet cotton and then wipe it dry with a cloth.
2. Never use alcohol to clean the drum. Alcohol will dissolve the drum surface.
3. Store the PCU in a cool dry place.
4. Do not expose the drum to corrosive gases (ammonia, etc.).
5. Do not shake a used PCU, as this may cause toner and developer to spill out.
6. Dispose of used PCU components in accordance with local regulations.

3.1.2 TRANSFER ROLLER

1. Never touch the surface of the transfer roller with bare hands.
2. Be careful not to scratch the transfer roller, as the surface is easily damaged.

3.1.3 SCANNER UNIT

1. Use alcohol or glass cleaner to clean the exposure and scanning glass. This will reduce the static charge on the glass.
2. Use a blower brush or a water-moistened cotton pad to clean the mirrors and lenses.
3. Take care not to bend or crease the exposure lamp's ribbon cable.
4. Do not disassemble the lens unit. Doing so will throw the lens and copy image out of focus.
5. Do not turn any of the CCD positioning screws. Doing so will throw the CCD out of position.

SPECIAL TOOLS AND LUBRICANTS

3.1.4 LASER UNIT

1. Do not loosen or adjust the screws securing the LD drive board on the LD unit. Doing so will throw the LD unit out of adjustment.
2. Do not adjust the variable resistors on the LD unit. These are adjusted at the factory.
3. The polygonal mirror and F-theta lens are very sensitive to dust.
4. Do not touch the toner shield glass or the surface of the polygonal mirror with bare hands.

3.1.5 FUSING UNIT

1. After installing the fusing thermistor, make sure that it is in contact with the hot roller and that the roller can rotate freely.
2. Be careful to avoid damage to the hot roller stripper pawls and their tension springs.
3. Do not touch the fusing lamp and rollers with bare hands.
4. Make sure that the fusing lamp is positioned correctly and that it does not touch the inner surface of the hot roller.

3.1.6 PAPER FEED

1. Do not touch the surface of the paper feed rollers.
2. To avoid misfeeds, the side and end fences in each paper tray must be positioned correctly so as to align with the actual paper size.

3.1.7 IMPORTANT

1. After installing a new PCU, you must run SP2-214 to initialize the TD sensor. After starting initialization, be sure to wait for it to reach completion (wait for the motor to stop) before re-opening the front cover or turning off the main switch.
2. If the optional tray heater or optics anti-condensation heater is installed, keep the copier's power cord plugged in even while the main switch is off, so that the heater(s) remain energized.

3.2 SPECIAL TOOLS AND LUBRICANTS

Part Number	Description	Q'ty
A0069104	Scanner Positioning Pins (4 pins/set)	1 set
A2929500	Test Chart S5S (10 pcs/set)	1 set
A0299387	FLUKE 87 Digital Multimeter	1
A2309352	4MB Flash Memory Card	1
A2579300	Grease Barrierta S552R	1
52039502	Grease G-501	1
B0399099	NVRAM – Minus Counter	1
G0219350	Loop-back Connector	1

3.3 EXTERIOR COVERS & OPERATION PANEL

3.3.1 REAR COVER

1. Unplug the DF cable [A].
2. Rear cover [B] (⚙ x 6)

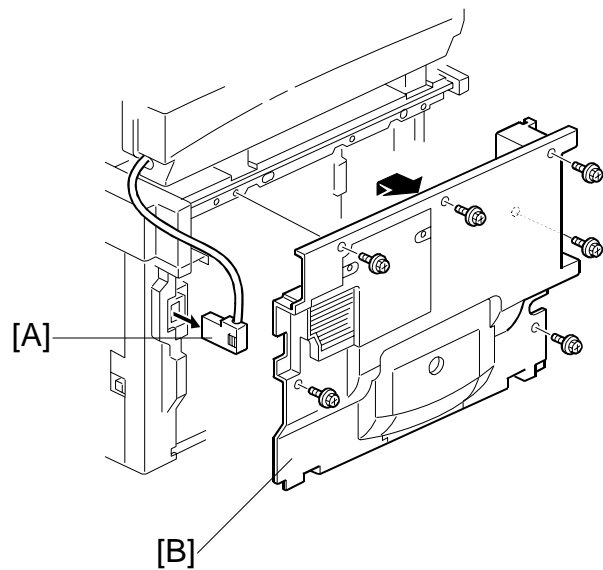

Replacement
Adjustment

3.3.2 REAR LOWER COVER (TWO-TRAY MODELS ONLY)

1. Rear cover (☞ 3.3.1) or tray harness cover [C] (1 rivet).
2. Rear lower cover [D] (⚙ x 2)

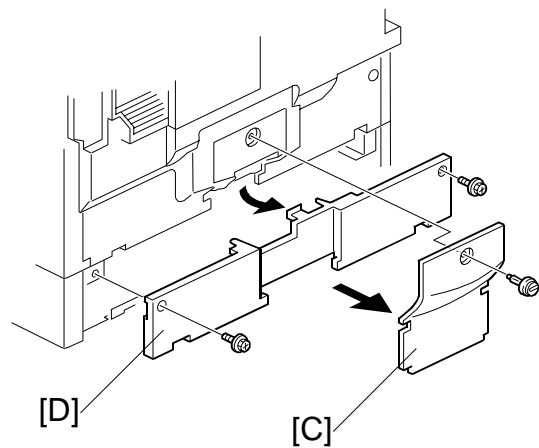

3.3.3 COPY TRAY

1. *Duplex models only*: Inverter tray [A]
2. Copy tray [B] (🔩 x 2)

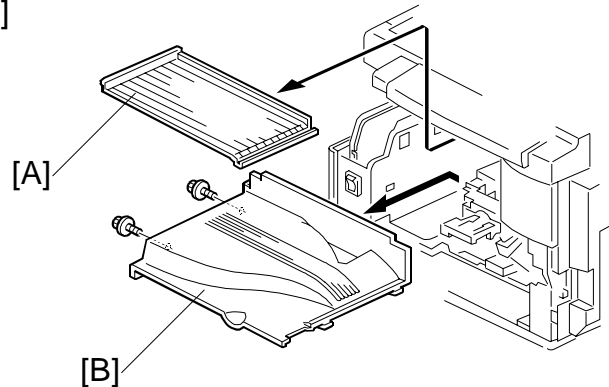

3.3.4 LEFT UPPER COVER

1. Rear cover (☛ 3.3.1)
2. Left upper cover [C] (🔩 x 2)

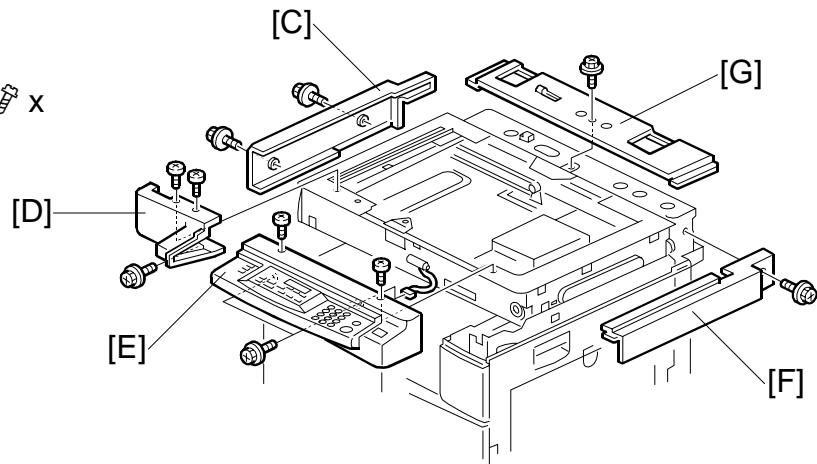

3.3.5 FRONT UPPER LEFT COVER AND OPERATION PANEL

1. Front upper left cover [D] (🔩 x 3)
2. Operation panel [E] (🔩 x 3, 🖱️ x 1)

3.3.6 RIGHT UPPER COVER

1. Right upper cover [F] (🔩 x 1)

3.3.7 TOP REAR COVER

1. Platen cover *or* ARDF *or* ADF (☛ 1.2, 1.3, or 1.4)
2. Top rear cover [G] (🔩 x 1)

3.3.8 LEFT COVER

1. Copy tray (☛ 3.3.3)
2. Rear cover (☛ 3.3.1)
3. Left cover [A] (🔩 x 2)

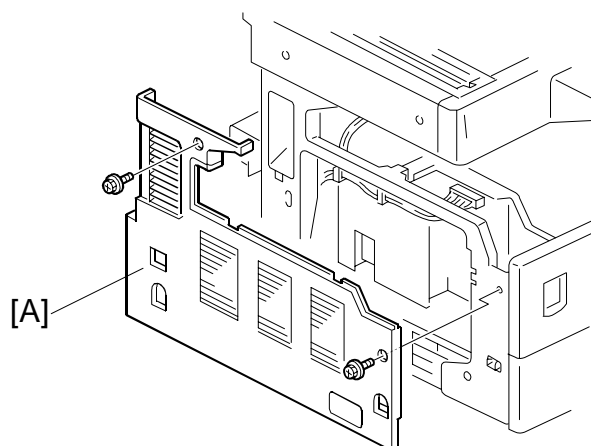

Replacement
Adjustment

3.3.9 FRONT LONG COVER

1. Open the front door [B].
2. Pull out the (top) paper tray.
3. Front long cover [C] (🔩 x 4)

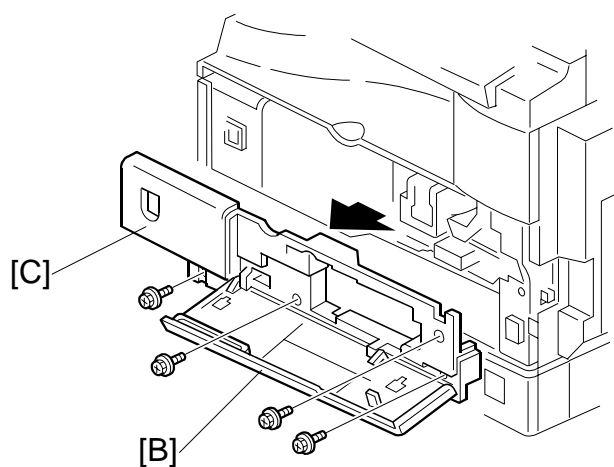

3.3.10 FRONT RIGHT COVER

1. Open the front door [A].
2. Front right cover [B] (🔩 x 1)

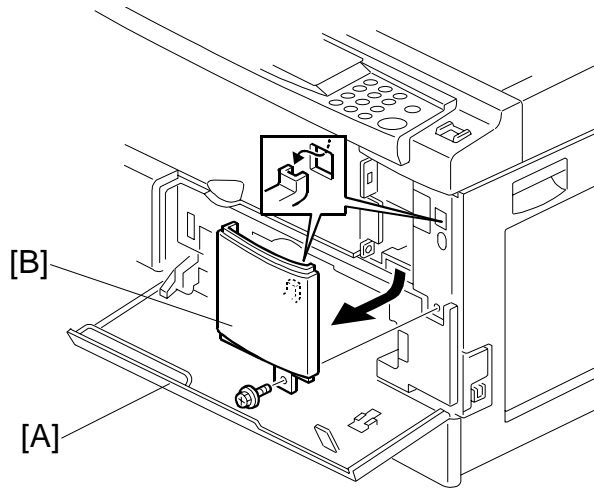

3.3.11 RIGHT REAR COVER

1. Right upper cover (☞ 3.3.6)
2. Right rear cover [C] (🔩 x 1)

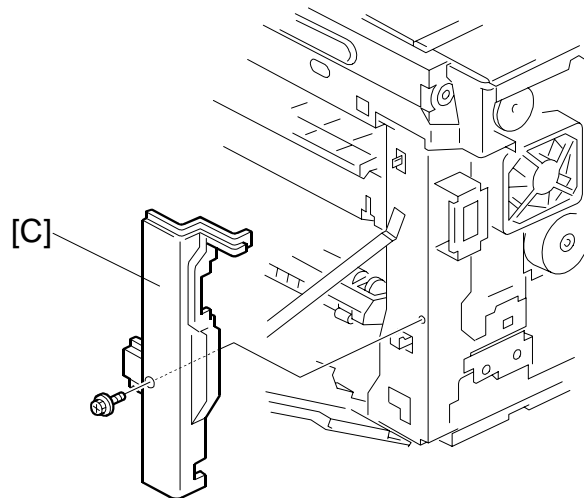

3.3.12 RIGHT DOOR

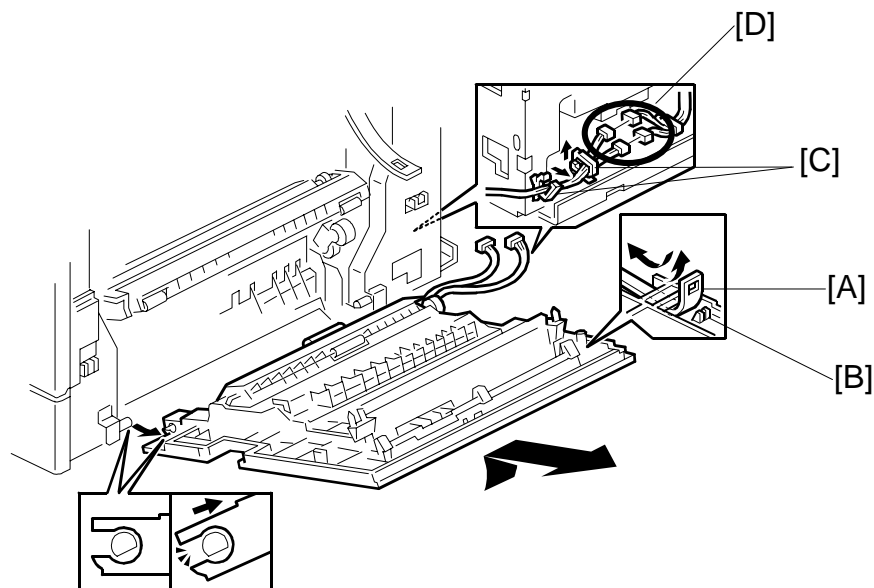

Replacement
Adjustment

1. Undo the strap [A] and lower the right door.
NOTE: On non-duplex models (shown in the drawing above), hold the door open part way and push the strap toward the door so that it comes loose from the peg [B] on the door. On duplex models (not shown), unscrew the strap (⚙ x 1) from the main unit.
2. Rear cover (☛ 3.3.1)
3. Right rear cover (☛ 3.3.11)
4. Open the 2 clamps [C] and disconnect the connectors [D].
NOTE: On non-duplex models (shown in the drawing above), disconnect 2 connectors. On duplex models, disconnect 3 connectors.
5. Pull the door off at an angle, so that it comes free of the hinges.

3.3.13 BY-PASS TRAY

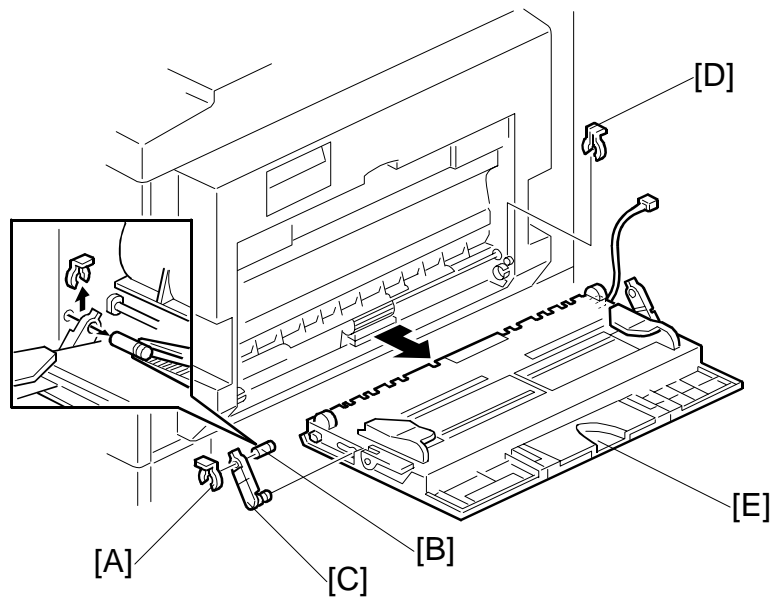

1. Rear cover (☛ 3.3.1)
2. Right rear cover (☛ 3.3.11)
3. Open the two clamps (see [C] on preceding page) and disconnect the connector coming from the by-pass tray (5-pin connector with colored wires). Move the connector clear of the other wires, so that it will come out without snagging when you take off the by-pass tray.
4. Lower the right door. (☛ 3.3.12)
5. Open the wire harness on the inside of the right door (B043 model only).
6. Close the right door again temporarily (you do not need to refasten the strap).
7. Front-side clip ring [A], front-side pin [B], front-side tray holder arm [C], and rear-side clip ring [D]
8. By-pass tray [E]

3.3.14 LEFT LOWER COVER (TWO-TRAY MODELS ONLY)

1. Left lower cover [A] (🔩 x 2)

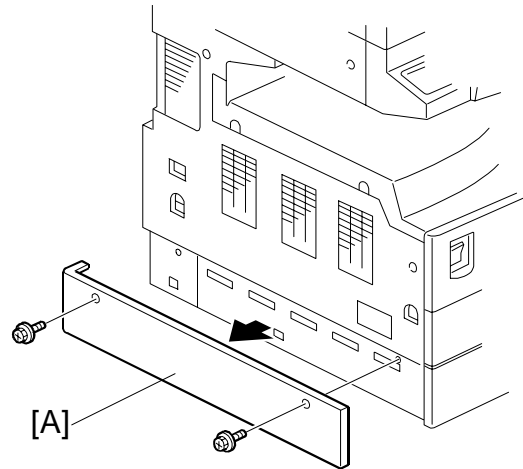

Replacement
Adjustment

3.3.15 RIGHT LOWER COVER (TWO-TRAY MODELS ONLY)

1. Open the right lower cover [B].
2. Right lower cover (1 rivet)

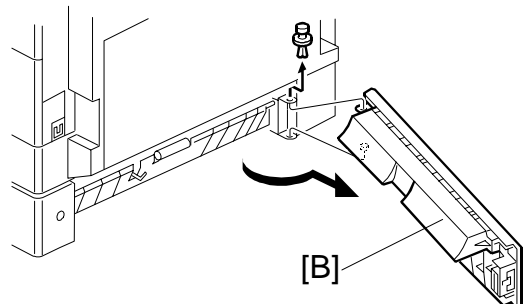

3.3.16 PLATEN COVER SENSOR

1. Top rear cover (☛ 3.3.7)
2. Platen cover sensor [C] (🔌 x 1)

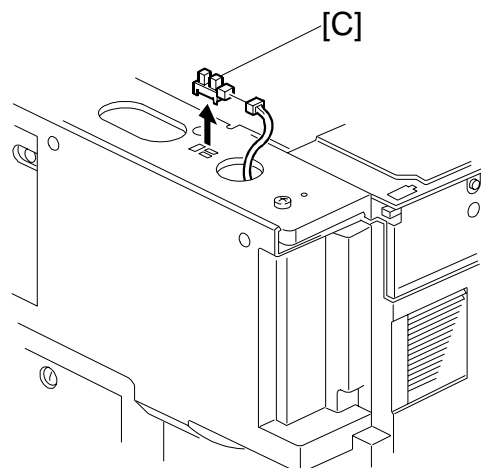

3.4 SCANNER SECTION

3.4.1 EXPOSURE GLASS/DF EXPOSURE GLASS

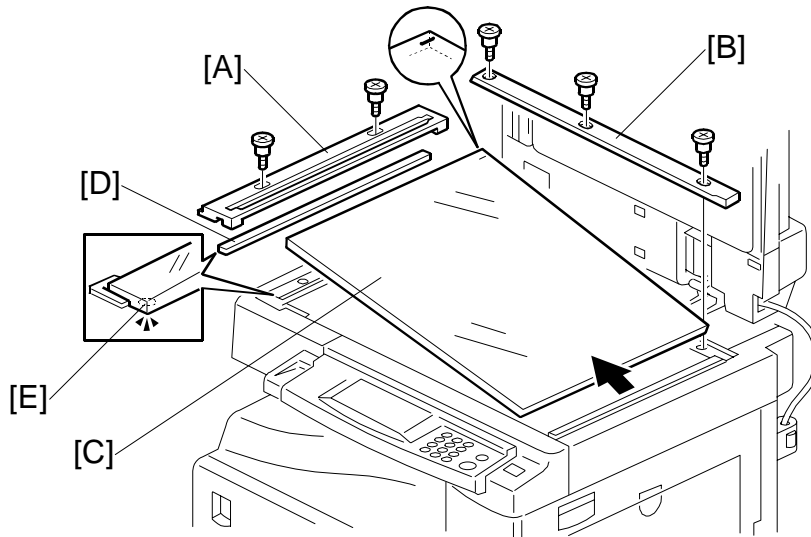

Exposure Glass

1. Left scale [A] (⚙ x 2)
2. Rear scale [B] (⚙ x 3)
3. Exposure glass [C]

NOTE: When reinstalling, be sure that the mark is at the rear left corner, and be sure to set the exposure glass so that its left edge is aligned flush against the small support ridge on the frame.

DF Exposure Glass

1. Left scale [A]
2. DF exposure glass [D]

NOTE: When reinstalling, be sure that the mark [E] is facing down

3.4.2 LENS BLOCK

1. Exposure glass (☛ 3.4.1)
2. Lens cover [A] (🔩 x 5)
3. Disconnect the flat cable [B].
4. Lens block [C] (🔩 x 4).

NOTE: Do not loosen the paint-locked screws holding the lens unit in place.

After installing the new lens block, do the copy adjustments (☛ 3.13).

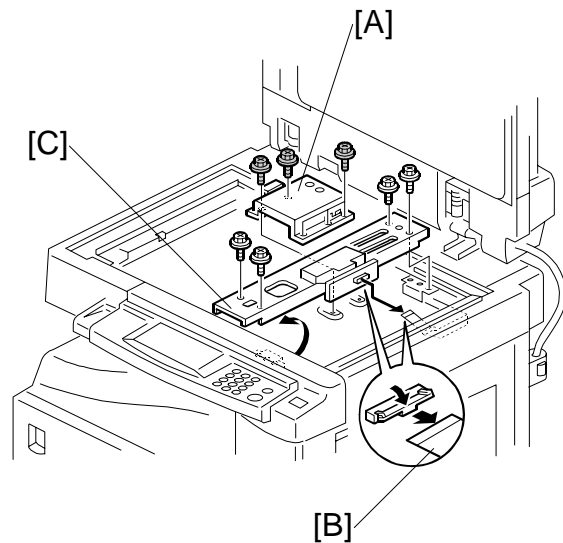

Replacement
Adjustment

3.4.3 EXPOSURE LAMP, LAMP STABILIZER BOARD

1. Exposure glass (☛ 3.4.1)
2. Operation panel (☛ 3.3.5)
3. Slide the 1st scanner to a position where the front end of the lamp is clear of the metal lids.
4. Place your right hand under the lamp stabilizer board [D] on the underside of the 1st scanner, to support the board when it drops. Press hook [E] with your left thumb to release the board.
5. Disconnect the lamp connector [F]. If you wish, you can now remove the lamp stabilizer board (by disconnecting the flat cable).
6. Remove the front reflector [G].
7. Press on the plastic latch [H] and at the same time push the plastic end of the lamp toward the rear, so that the lamp snaps free. Remove the lamp together with the lamp cable.

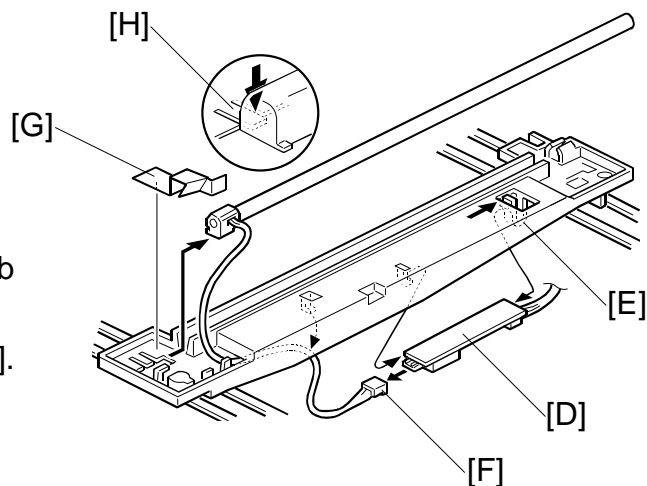

SCANNER SECTION

3.4.4 ORIGINAL WIDTH SENSOR

1. Exposure glass (☛ 3.4.1)
2. Original width sensor [A] (🔧 x 1, 📏 x 1)

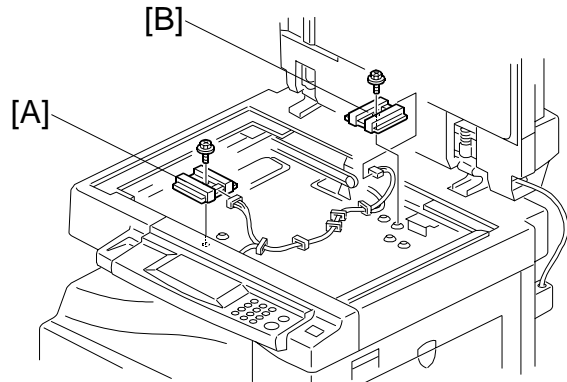

3.4.5 ORIGINAL LENGTH SENSOR

1. Exposure glass (☛ 3.4.1)
2. Lens block (☛ 3.4.2)
3. Original length sensor [B] (🔧 x 1, 📏 x 1)

Sensor Positions

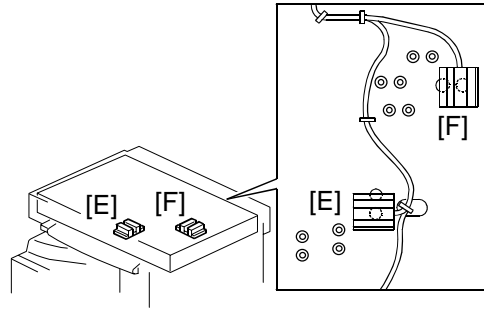
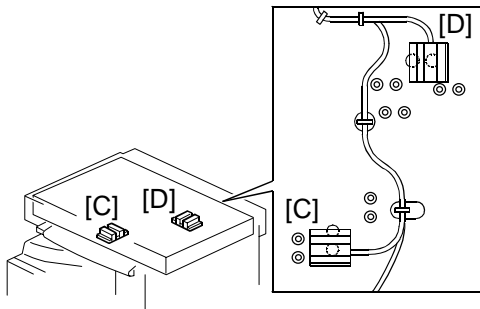

Sensor positions vary according to region, as indicated below.

[C], [D]: Europe, Asia, Taiwan

[E], [F]: America

[G], [H]: China

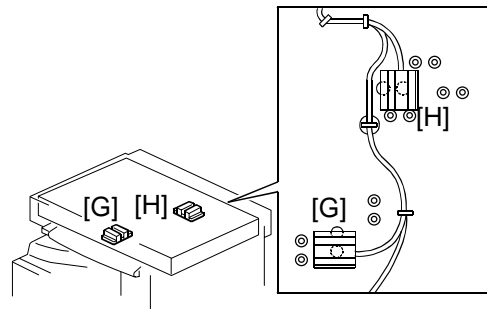

3.4.6 CHANGING THE ORIGINAL SENSOR POSITIONS (8K/16K)

This procedure is for China models only. To enable detection of the following original sizes, the original sensors must be moved from their factory-set positions to the locations indicated in the drawing below right.

- 8K SEF (270 x 390 mm)
- 16K SEF (195 x 270 mm)
- 16K LEF (270 x 195 mm)

Once the sensors have been moved, they will detect paper sizes as follows.

Original Size	Length Sensors		Width Sensors	
	L1	L2	W1	W2
8K-SEF	○	○	○	✗
16K-SEF	○	✗	✗	✗
16K-LEF	✗	✗	○	✗

○: Original present ✗: Original not present

SCANNER SECTION

Procedure

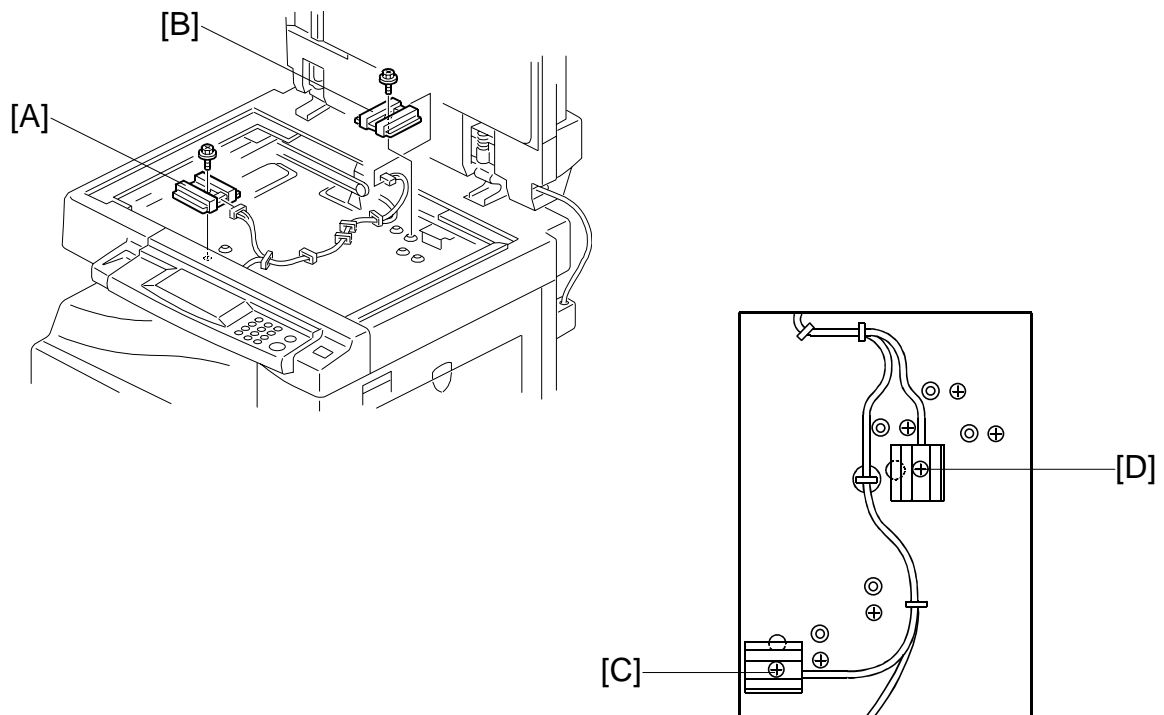

1. Set the machine to detect 8K/16K originals as follows.
 - *If the machine is equipped with the platen cover.* Access SP mode 5-955-1, and set the setting to 1 (=Yes). The machine will now detect 8K/16K rather than B4/B5. (B4-SEF → 8K-SEF; B5-SEF → 16K-SEF; B5-LEF → 16K-LEF)
 - *If the machine is equipped with the ADF or ARDF.* Access SP mode 5-955-2, and set the setting to 1 (=Yes). The machine will now detect 8K/16K rather than A3/A4/B4/B5. (A3-SEF/B4-SEF → 8K-SEF; B5-SEF/A4-SEF → 16K-SEF; B5-LEF/A4-LEF → 16K-LEF)
 - Note that making either of the above settings will disable use of SP mode 5-911.
2. Turn off the power, and remove the exposure glass (☛ 3.4.1).
3. Remove APS sensors [A, B].
4. Remove screws [C, D] at the new mount positions.
5. Mount the original width sensor into the new position (from where you removed screw [C]), and screw.
6. Mount the original length sensor into the new position (from where you removed screw [D]), and screw it.
7. Screw screws back into their original holes.

3.4.7 SCANNER MOTOR

1. Rear cover (☛ 3.3.1)
2. Right upper cover (☛ 3.3.6)
3. Rear scale and exposure glass (☛ 3.4.1)
4. Operation panel (☛ 3.3.5)
5. Top rear cover (☛ 3.3.7)
6. Detach the belt [A].
7. Scanner motor [B] (⚙️ x 3, 1 spring, 📏 x 1)

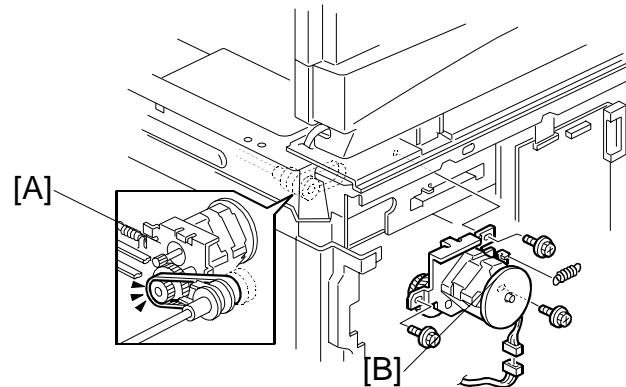

NOTE: When reinstalling the motor:

Fit the belt on first, then set the spring in place, and then screw in evenly, rotating from screw to screw so that the spring tension is correctly distributed.

After installing the motor, do the copy adjustments (☛ 3.13).

3.4.8 SCANNER H.P. SENSOR

1. Left upper cover (☛ 3.3.4)
2. Top rear cover (☛ 3.3.7)
3. Exposure glass (☛ 3.4.1)
NOTE: If the machine is an A(R)DF model, remove both the DF exposure glass and the exposure glass.
4. Disconnect the scanner H.P. sensor connector [C].
5. Scanner left lid [D] (⚙️ x 7)
6. Remove the sensor tape [E].
7. Scanner H.P. sensor [F]

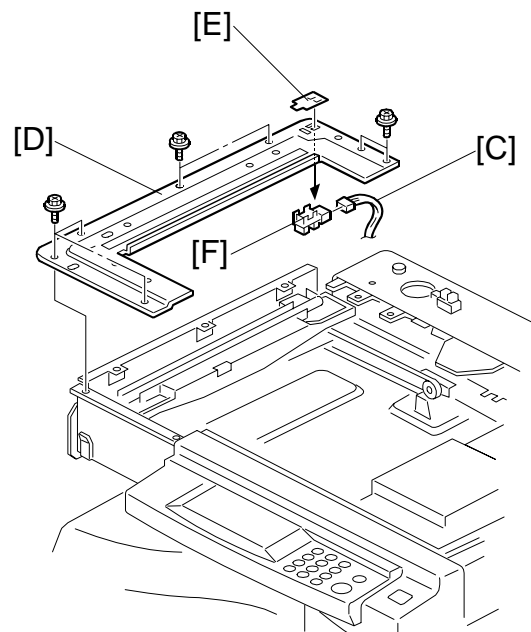

3.4.9 ADJUSTMENT OF 2ND SCANNER POSITION

Do this procedure after replacing a scanner belt. If you replaced the second scanner belts, go onto the next section ('Adjustment of 1st and 2nd Scanner Alignment'.)

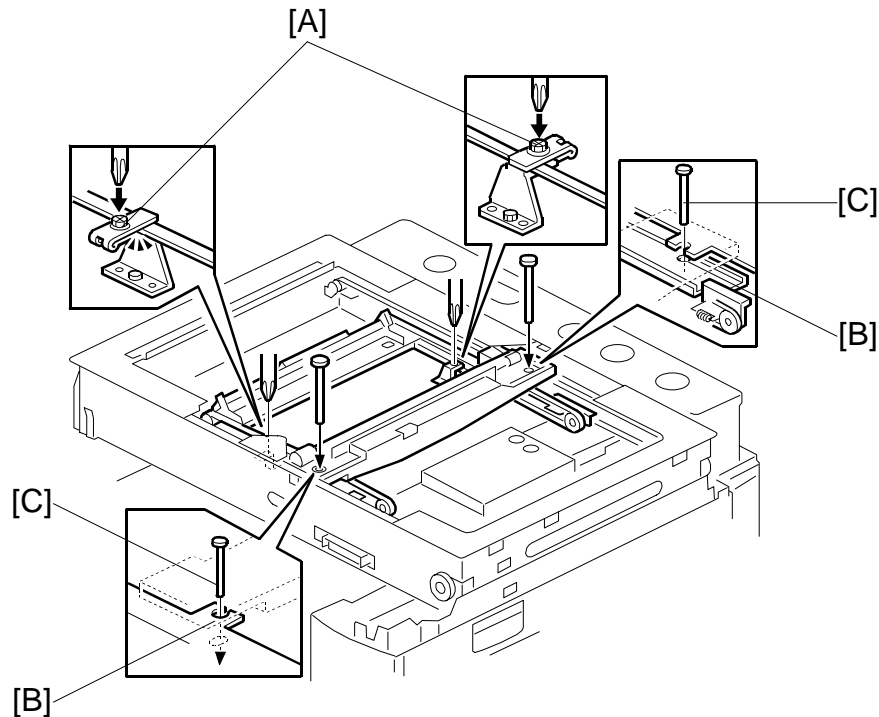

1. Remove the A(R)DF or platen cover.
2. Remove the operation panel (☛ 3.3.5).
3. Remove the top rear cover (☛ 3.3.7).
4. Loosen the 2 screws [A] holding the 2nd scanner belt in place.
5. Slide the 2nd scanner so that the second hole from the right on each scanner arm is roughly aligned with the position guide holes [B] on the upper and lower mainframe rims.
6. Insert the positioning tools [C] into both sets of holes.
NOTE: If the 1st scanner is preventing the pins from fitting in smoothly, loosen the 1st scanner securing screws and slide the 1st scanner out of the way (☛ 3.4.10, step 1).
7. Re-tighten the screws loosened in step 1 [A] and remove the positioning tools.
8. Go on to the next section, 'Adjustment of 1st and 2nd Scanner Alignment'.

3.4.10 ADJUSTMENT OF 1ST AND 2ND SCANNER ALIGNMENT

For how to use this procedure, see the previous section, 'Adjustment of 2nd Scanner Position'.

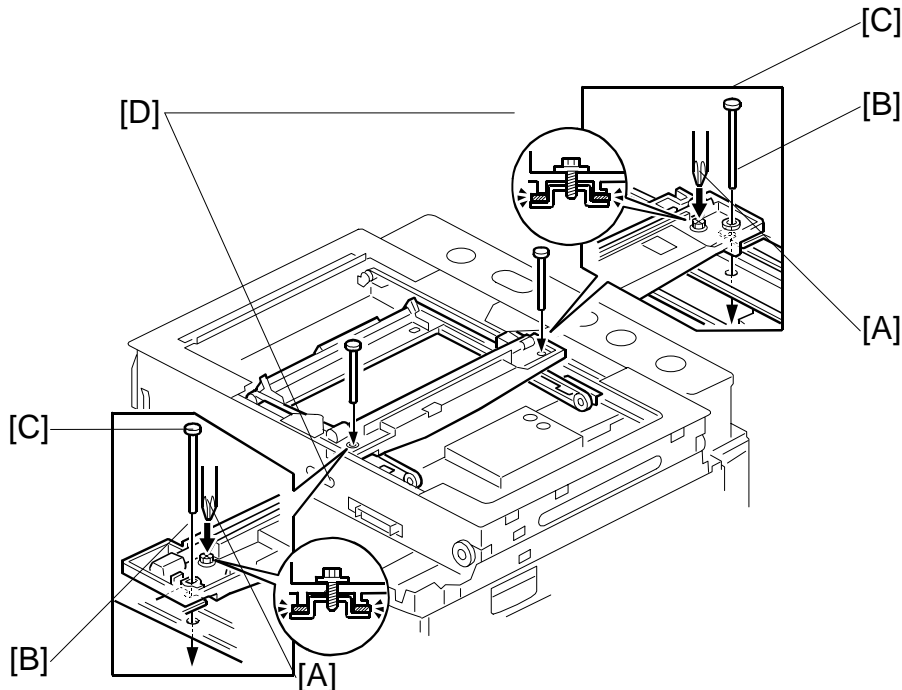

Replacement
Adjustment

1. Remove the A(R)DF or platen cover.
2. Remove the operation panel (☛ 3.3.5).
3. Remove the top rear cover (☛ 3.3.7).
4. Loosen the 2 screws [A] holding the 1st and 2nd scanner belts in place.
5. Slide the 1st and 2nd scanners so that all three of the following are aligned on both sides:
 - The second hole from the right on each 2nd scanner arm
 - The position guide holes on the upper and lower mainframe rims
 - The 1st scanner position guide hole [B]
6. Insert the positioning tools [C] into both sets of holes.
7. Make sure that both the 1st and 2nd scanner belts are properly set in place on both sides [D].
8. Re-tighten the screws loosened in step 1 [A] to clamp the scanner belts in place, then remove the positioning tools.

LASER UNIT

3.5 LASER UNIT

WARNING

Laser beam can seriously damage your eyes. Be absolutely sure that the main power switch is off and that the machine is unplugged before accessing the laser unit.

3.5.1 LOCATION OF “CAUTION” DECAL

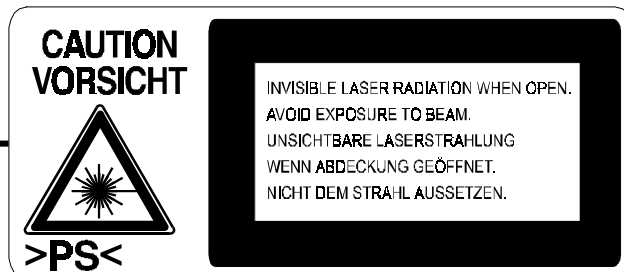
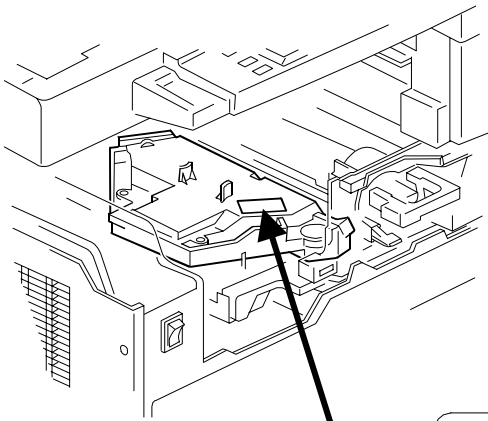

3.5.2 TONER SHIELD GLASS

1. Open the front door.
2. Lift the toner cartridge latch [A].
3. Press the toner shield glass cover [B] to the left and pull it out.
4. Pull out the toner shield glass [C].

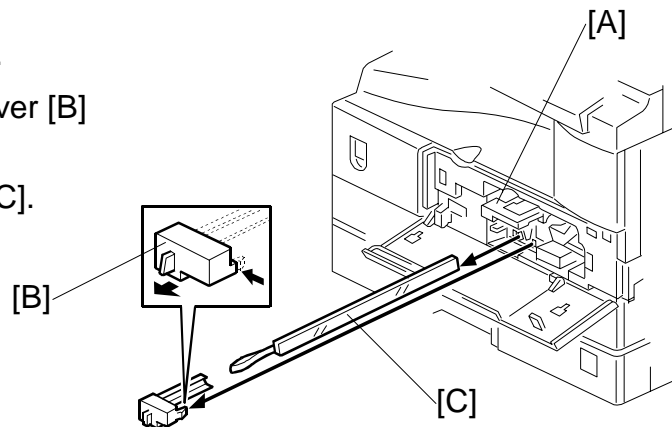

Replacement
Adjustment

3.5.3 LASER UNIT

1. Toner shield glass. (☞ 3.5.2)
2. Copy tray (☞ 3.3.3)
3. Pull out the (upper) paper tray.
4. Front long cover (☞ 3.3.9)
5. Disconnect the harness [D, E].
6. Laser unit [F] (⚙ x 4)

NOTE: The screw at the left front position [G] is longer than the others.

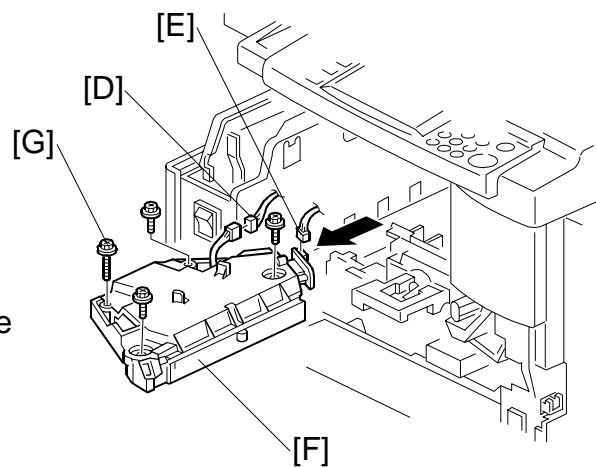

LASER UNIT

3.5.4 LD UNIT

1. Laser unit (☛ 3.5.3)

2. LD unit [A] (🔩 x 1)

NOTE: Do not screw the LD unit in too tightly when installing it.

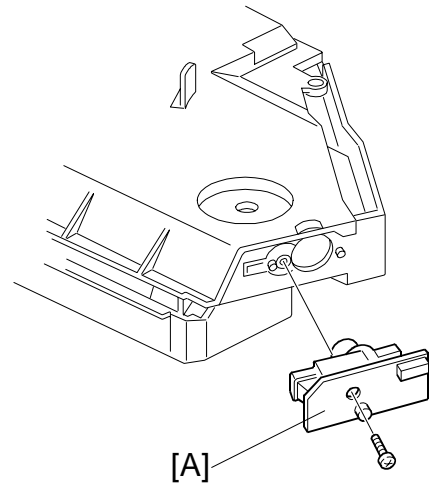

3.5.5 POLYGONAL MIRROR MOTOR

1. Laser unit (☛ 3.5.3)

2. Two rubber bushings [B]

3. Laser unit cover [C] (🔩 x 1)

4. Polygonal mirror motor [D] (🔩 x 4)

5. Do the copy adjustments (☛ 3.13).

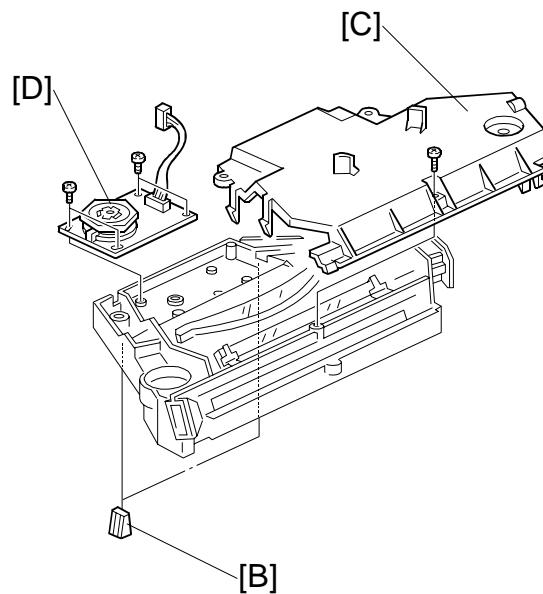

3.5.6 LASER UNIT ALIGNMENT ADJUSTMENT

⚠ WARNING

Be absolutely sure to reinstall the copy exit tray before making printouts. The laser beam can seriously damage your eyes.

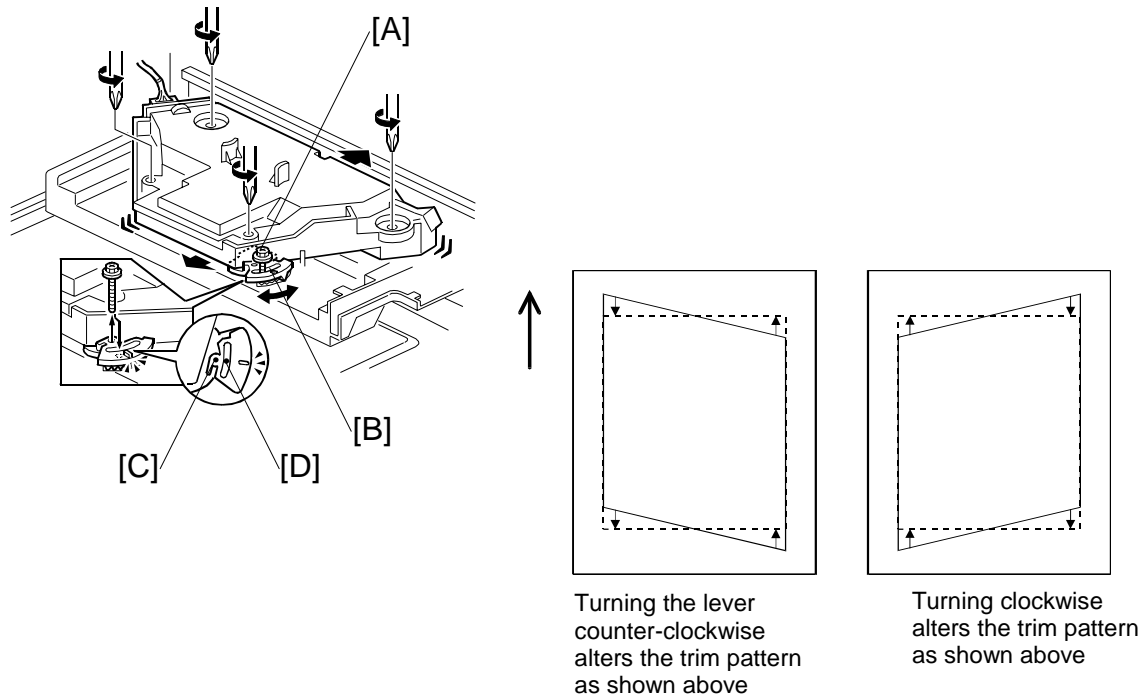

Replacement
Adjustment

1. Use SP5-902 to output a trim pattern (pattern 10). If the pattern is not even, adjust the alignment as follows.
2. Copy tray (☛ 3.3.3)
3. Loosen the four screws securing the laser unit (☛ 3.5.3).
4. *If this is the first time this adjustment is being made:* Remove the adjustment-lever screw [A] (securing the adjustment lever [B]) from its factory set position at [C], and loosely screw it in at the center of the long hole [D].
NOTE: If you have already adjusted the alignment at least once, the screw will already be in the long hole. If readjustment is necessary, just loosen the screw and continue as follows.
5. Rotate the lever clockwise or counterclockwise. This allows you to shift the corners of the pattern ± 0.4 mm with respect to the leading and trailing edges of the paper. Using trial and error, adjust until the trim pattern is even.
6. Tighten screw [A] at its new position.
7. Tighten the other three screws.
8. Reinstall the copy tray.
9. Print the trim pattern and check the result. If further adjustment is required, repeat this procedure.

3.6 PCU SECTION

3.6.1 PCU

1. Toner bottle holder (☛ 1.2.3, step 2)
2. Open the right door.
3. Press in on the latch, and pull out the PCU. (☛ 1.2.3, step 3)
NOTE: Do not touch the OPC drum surface with bare hands.
4. Load new developer. (☛ 3.6.7)
5. After reinstalling, run SP2-214 to reinitialize the TD sensor.
6. Do steps 1 to 6 of the procedure in section 3.6.8.

3.6.2 PICK-OFF PAWLS

1. Take out the PCU (☛ 3.6.1) or open the right door.
2. Pull each pawl [A] out from the bottom.
3. Do the procedure in section 3.6.8.

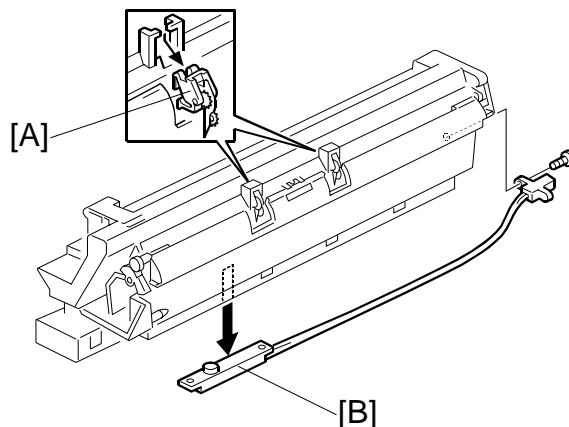

3.6.3 TONER DENSITY SENSOR

1. PCU (☛ 3.6.1)
2. The toner density sensor [B] is taped to the bottom of the PCU. Pry it off with a regular screwdriver (☛ x 1).
NOTE: Do not turn the PCU upside down, as doing so will cause toner and developer to spill out.
4. Do the procedure in section 3.6.8.

3.6.4 OPC DRUM

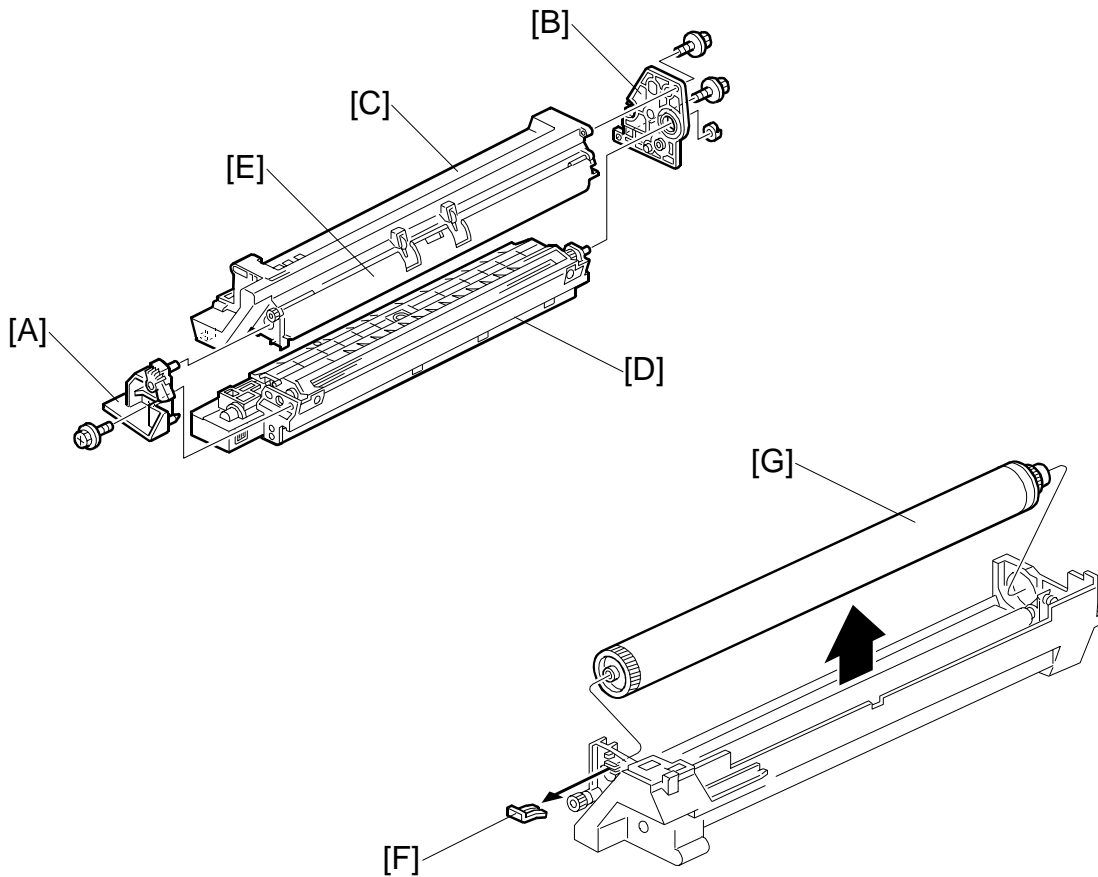

Replacement
Adjustment

1. PCU (☛ 3.6.1)
2. Remove the front side piece [A] (☛ x 1) and rear side piece [B] (☛ x 2, 1 coupling), and separate the PCU top part (drum section) [C] from its bottom part (developer section) [D]. Carry out the remaining steps on the drum section.
NOTE: To ensure that the left-side gears line up, be sure that the drum cover [E] is closed when reinserting the front side piece.
3. Pry out the drum retaining clip [F].
NOTE: Be sure to reinstall the clip in the same orientation (with the lip facing away from the drum shaft).
4. Pull out the front end of the OPC drum [G], and remove.
5. Do the procedure in section 3.6.8.

3.6.5 CHARGE ROLLER AND CLEANING BRUSH

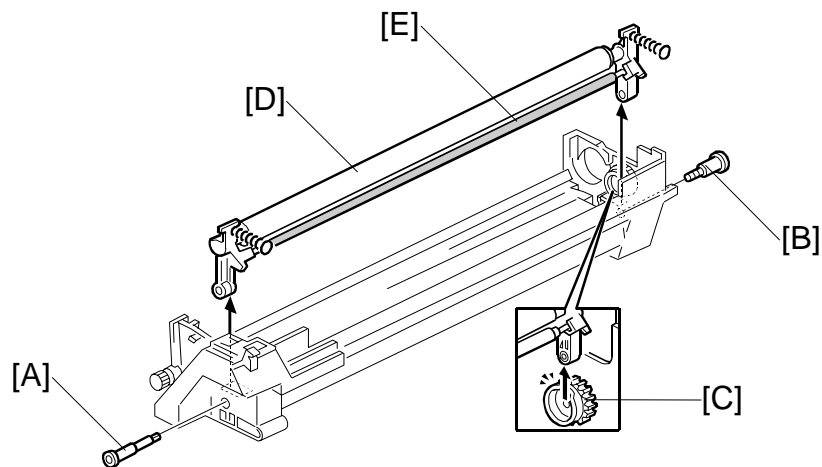

1. OPC Drum (☛ 3.6.4)
2. Remove holding pin [A] and 1 stepped screw [B].
3. Turn the gear [C] as necessary so that the rear end piece can come out.
4. Pull out the charge roller [D] and cleaning brush [E] as a single assembly (together with the plastic end pieces and springs).
5. Do the procedure in section 3.6.8.

3.6.6 CLEANING BLADE

1. Drum charge roller (☛ 3.6.5)
2. Cleaning blade [F] (🔩 x 2)
3. Do the procedure in section 3.6.8.

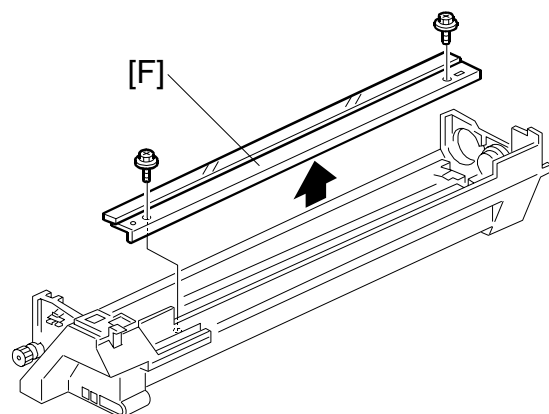

3.6.7 DEVELOPER

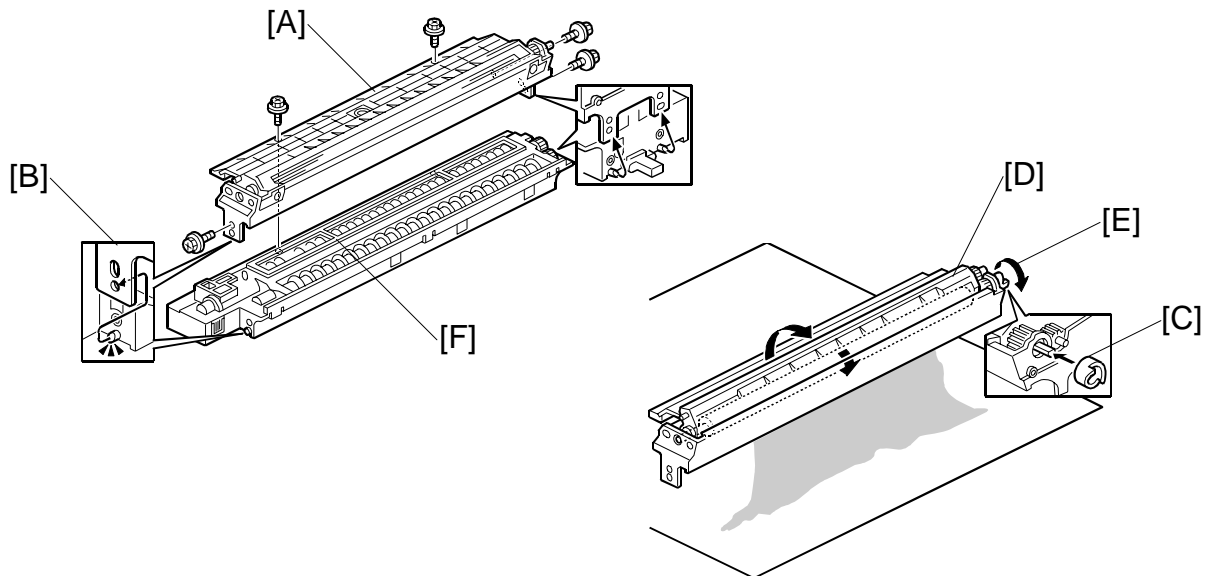

Replacement
Adjustment

1. PCU (☛ 3.6.1)
2. Tap the top of the PCU with a screwdriver at eight evenly spaced locations (two or three taps at each spot) so as knock the recycled toner down into the development section.
3. Set the PCU back into the mainframe.
4. Turn the main power on. Then open and close the door and wait for the machine to rotate the development roller for 10 seconds. Then open and close the door two more times, so that total rotation time is 30 seconds.
5. Remove the PCU again.
6. Separate the developer section from the OPC drum section (☛ 3.6.4, step 2).
7. Remove the top part [A] of the development unit (⚙ x 5), then place your finger under the front-side flap [B] and push out so that the flap pops off the peg.
8. Set the coupling [C] back onto the shaft, tilt the development roller [D] upward as shown, and turn the coupling (and shaft) in the direction of the arrow [E] to remove developer from the roller.
9. Turn the bottom part [F] of the developer unit over and rotate the gears to remove the developer.
10. Load new developer. (☛ 1.2.3, step 5)
11. After reinstalling, run SP2-214 to reinitialize the TD sensor.

NOTE: 1) Be sure that there is no toner or developer stuck on any of the gears.
(Clean as necessary with a blower brush, etc.)
2) Be sure to replace the Mylar at the rear side in the correct position. (The Mylar protects the gears at the rear side from falling toner).

3.6.8 AFTER REPLACEMENT OR ADJUSTMENT

IMPORTANT: After replacing or adjusting any of the PCU components, please do the following procedure.

1. Take 5 sample copies.
2. If black dots (dropped toner) appear on any of the copies, continue as follows. (If all copies are clean, you don't need to carry out the following steps.)
3. Remove the PCU from the mainframe.
4. Tap the top of the PCU with a screwdriver at eight evenly spaced locations (two or three taps at each spot), to knock the recycled toner down into the development section.
5. Put the PCU back into the mainframe.
6. Turn the main power on. Then open and close the door and wait for the machine to rotate the development roller for 10 seconds. Then open and close the door two more times, so that total rotation time is 30 seconds.
7. Make some sky-shot copies (or solid black prints).
 - If using A4/8 1/2" x 11" paper, make 4 copies/prints.
 - If using A3/11" x 17" paper, make 2 copies/prints.
 - To make solid black prints, use SP5-902 pattern 8.

NOTE: Step 7 is required only after parts replacement or adjustment. There is no need to make sky-shot (or solid black) copies after replacing the developer.

3.7 TONER SUPPLY MOTOR

1. Copy tray (☛ 3.3.3)
2. Open the front door.
3. Toner bottle holder (☛ 1.1.3, step 2)
4. Toner supply motor [A] (☛ x 1)

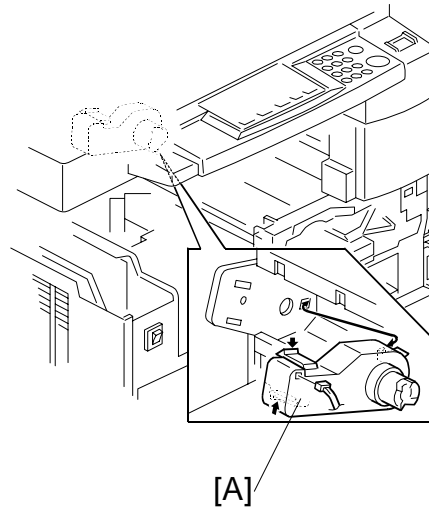

Replacement
Adjustment

3.8 PAPER FEED SECTION

3.8.1 PAPER FEED ROLLER

1. Pull out the appropriate paper tray.
2. Clip [A]
3. Push the shaft back through the opening, and tilt it up.

NOTE: If the black plastic bushing [B] comes off, be sure to remount it when reinstalling the shaft.

4. Paper feed roller [C]

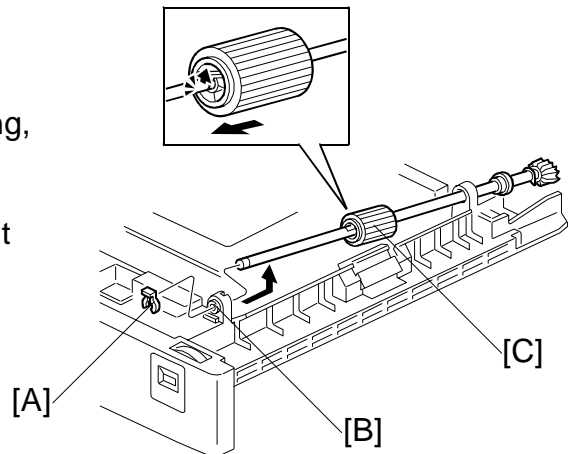

3.8.2 FRICTION PAD

1. Pull the appropriate paper cassette out.
2. Clip [D]
3. Push the shaft back through the opening, so that the roller moves clear of the friction pad.

4. Friction pad [E]

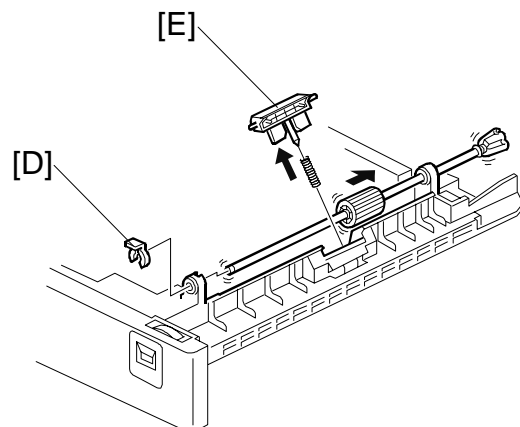

3.8.3 PAPER END SENSOR

1. Pull the appropriate paper cassette out.
2. Paper end sensor [F] (📄 x 1)

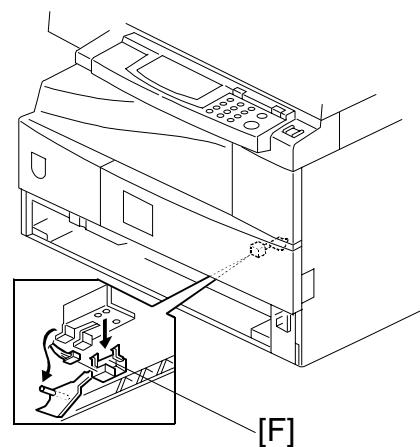

3.8.4 EXIT SENSOR

Non-duplex Models

1. Open the right door.
2. Front right cover (☛ 3.3.10)
3. Guide [A] (🔩 x 2)
4. Exit sensor [B] (🔩 x 1)

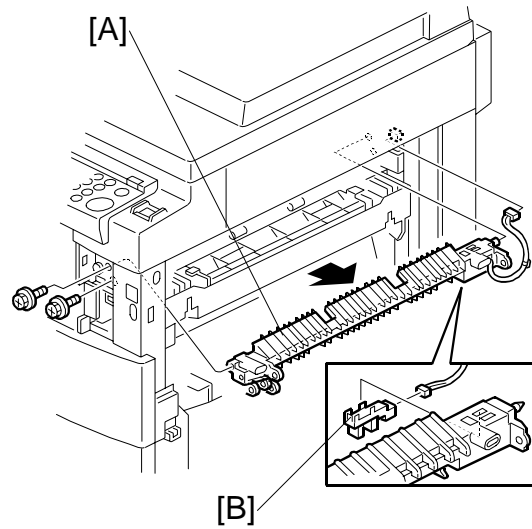

Replacement
Adjustment

Duplex Models

1. Open the right door.
2. Front right cover (☛ 3.3.10)
3. Lower guide [C] (🔩 x 2)
4. Upper guide [D] (🔩 x 2)
5. Exit sensor [E] (🔩 x 1)

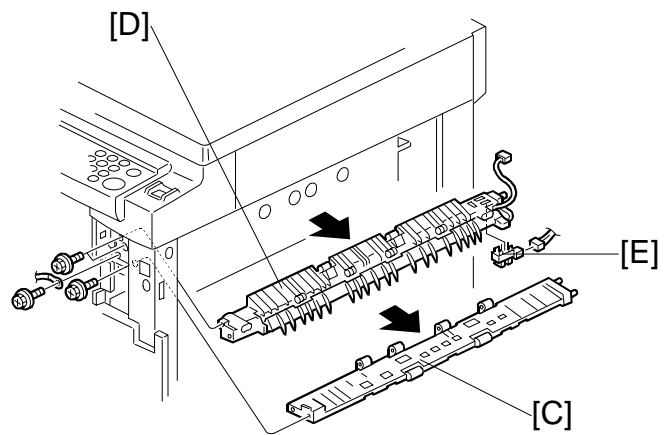

3.8.5 BY-PASS FEED ROLLER AND BY-PASS PAPER END SENSOR

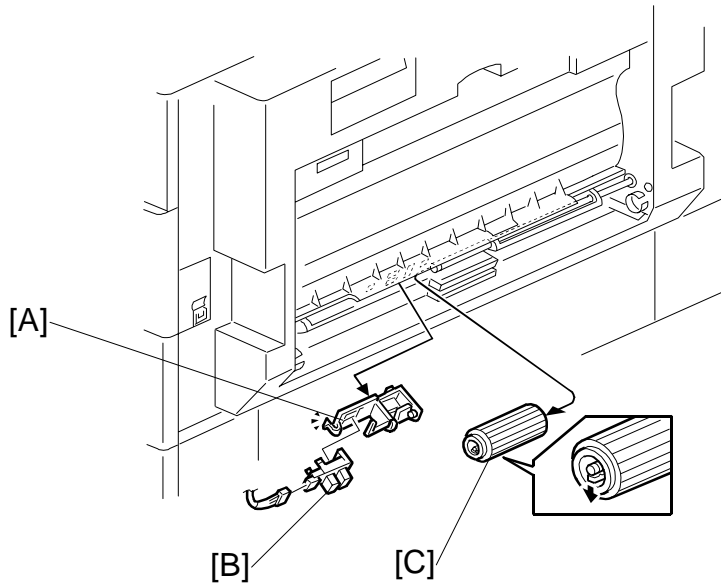

1. By-pass tray (☛ 3.3.13)

NOTE: If you wish, you can just detach the tray and rest it on the ground without disconnecting the connector (but be careful to avoid placing too much load on the wires).

2. Sensor holder [A].
3. By-pass paper end sensor [B] (☛ x 1)
4. By-pass feed roller [C]

3.8.6 REGISTRATION ROLLER

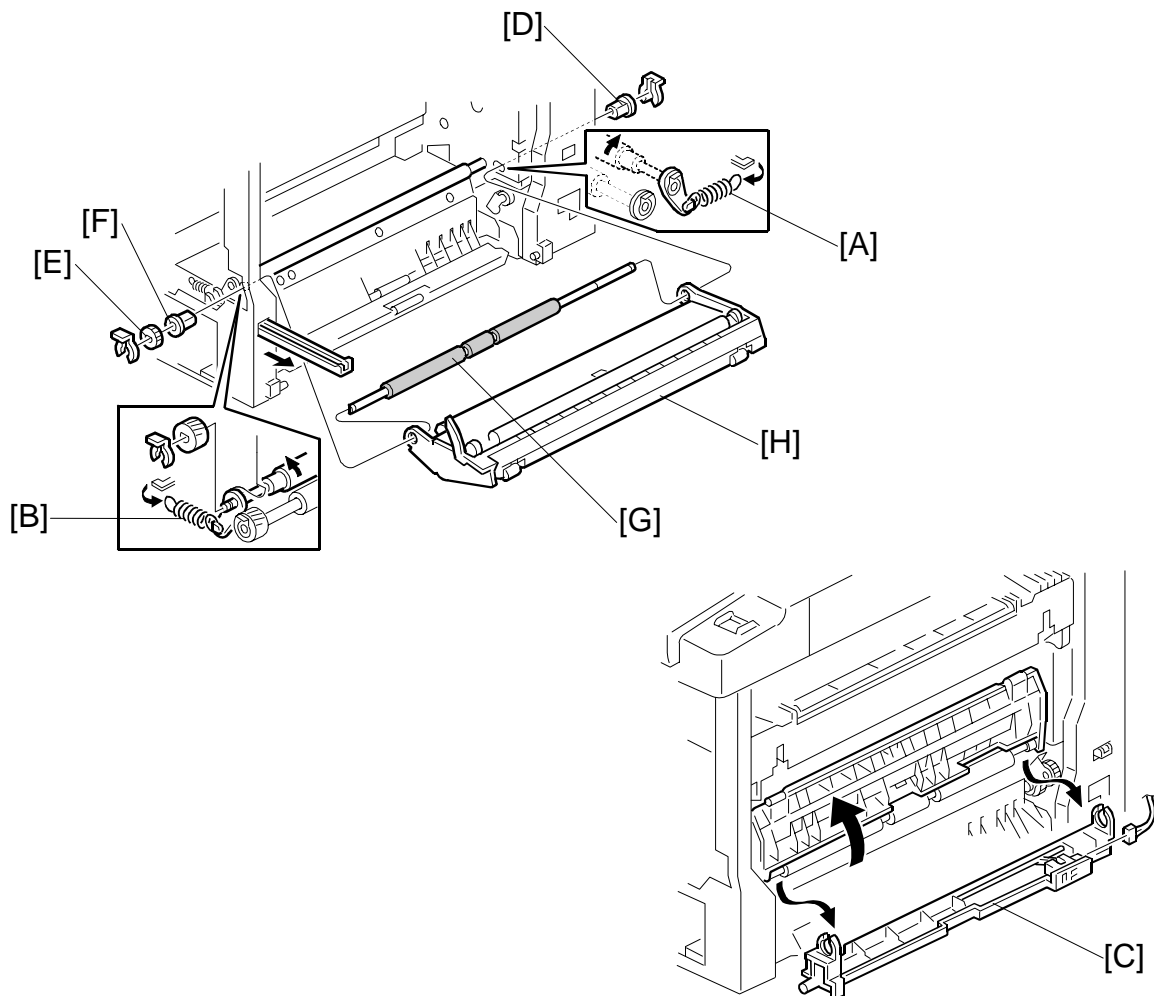

Replacement
Adjustment

1. PCU (☛ 3.6.1)
2. Front long cover (☛ 3.3.9)
3. Right door (☛ 3.3.12)
4. Rear cover (☛ 3.3.1)
5. High-voltage power supply (☛ 3.12.2)
6. Registration clutch (☛ 3.8.8)
7. Unhook the springs [A] and [B] at the rear and front sides.
8. Guide [C] (🔧 x 1, 📏 x 1)
9. Bushing [D] (🔧 x 1)
10. Gear [E] and bushing [F] (🔧 x 1)
11. Registration roller [G] with the image transfer unit [H]

3.8.7 BY-PASS PAPER SIZE SENSOR

1. By-pass tray (☛ 3.3.13)
2. Tray lever [A] (🔩 x 1, 1 pin)
3. Lift the upper tray [B]
4. By-pass paper size sensor [C] (🔩 x 1)

NOTE: When reinstalling the sensor: Move the paper guides to their middle position (about halfway between fully open and fully closed), and install the round gear so that the hole in the gear [D] aligns with the peg [E] on the sliding gear.

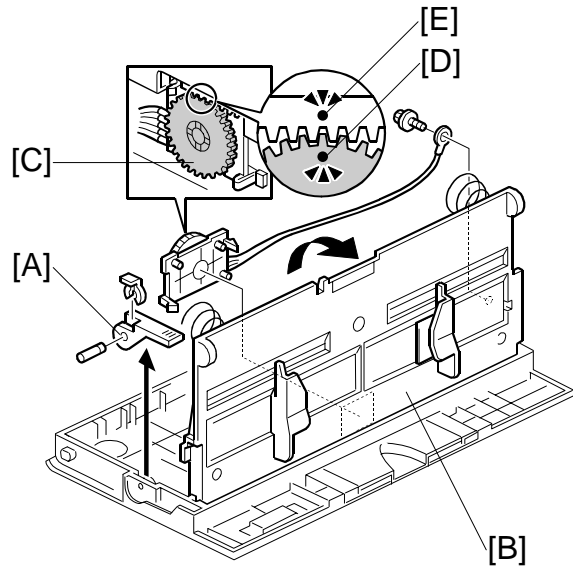

3.8.8 REGISTRATION CLUTCH

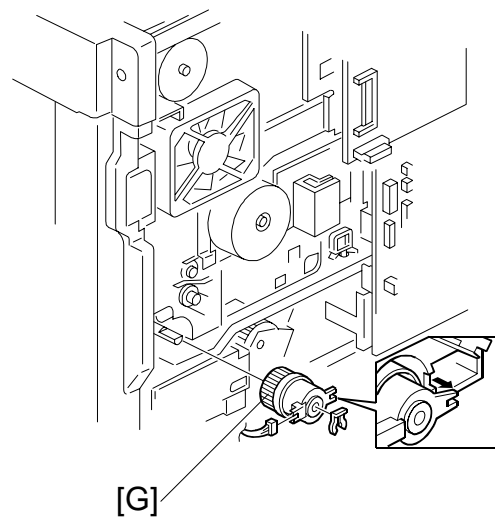
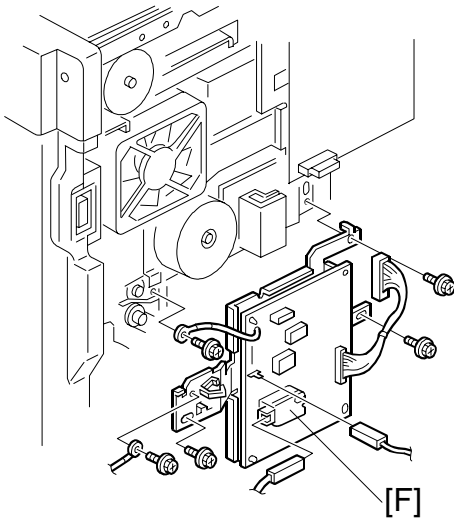

1. Rear Cover (☛ 3.3.1)
2. Bracket holding the high-voltage power supply board [F] (🔩 x 5, all connectors)
3. Registration clutch [G] (🔩 x 1, 📌 x 1)

3.8.9 REGISTRATION SENSOR

1. Open the right door.
2. Registration sensor [A] (🔌 x 1)

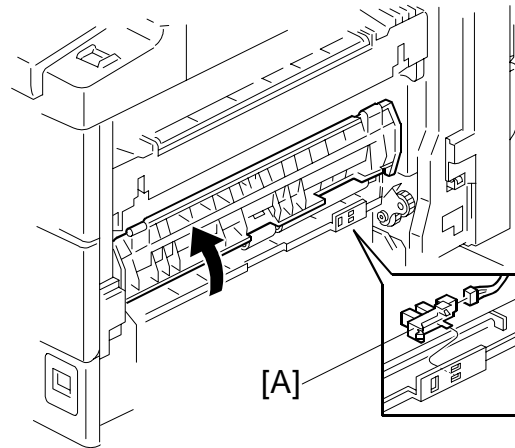

Replacement
Adjustment

3.8.10 UPPER PAPER FEED CLUTCH AND BY-PASS FEED CLUTCH

1. Rear cover (🔩 3.3.1)
2. Clutch cover [B] (🔩 x 2, 2 bushings, 🛠️ x 2)
3. Paper feed clutch [C] and by-pass feed clutch [D]

NOTE: When reinstalling, be sure that the rotation-prevention tabs [E] on the clutches fit correctly into the corresponding openings on the clutch cover.

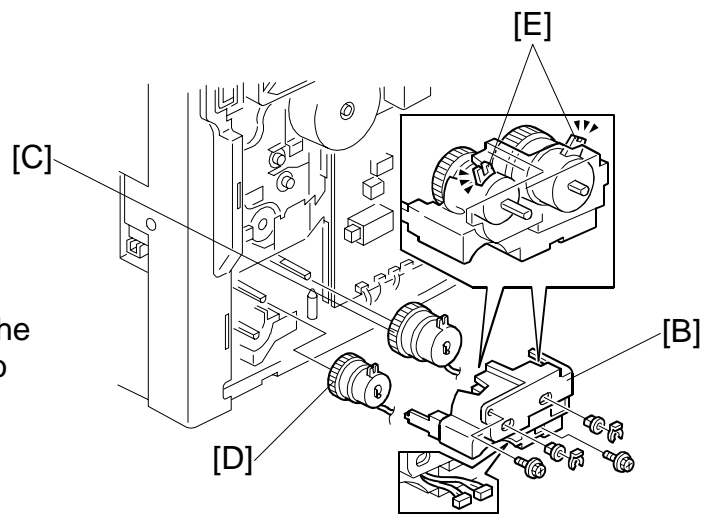

3.8.11 RELAY CLUTCH

1. Rear cover (☛ 3.3.1)
2. Relay clutch [A] (☛ x 1)

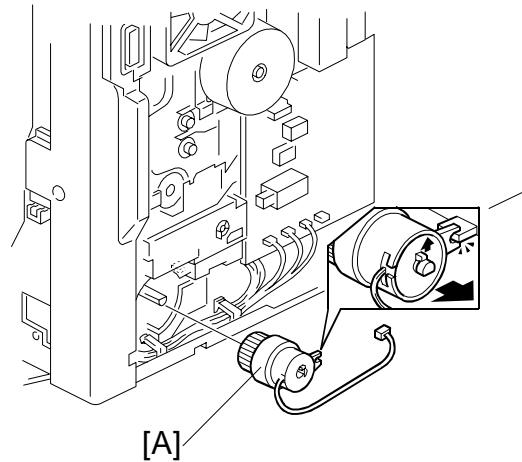

3.8.12 RELAY SENSOR

1. Relay clutch (☛ 3.8.11)
2. Sensor bracket [B] (☛ x 1)
3. Relay sensor [C] (☛ x 1)

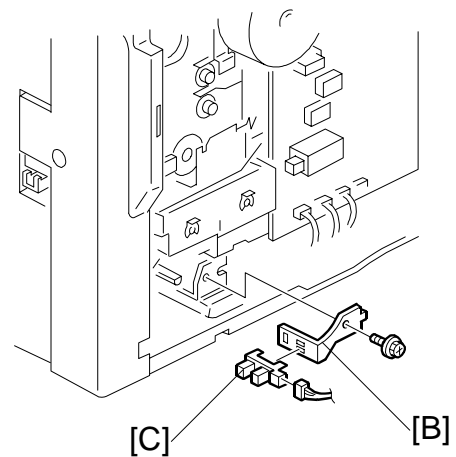

3.8.13 LOWER PAPER FEED CLUTCH (TWO-TRAY MODELS ONLY)

1. Rear lower cover (☛ 3.3.2)
2. Clutch bracket [D] (☛ x 2)
3. Lower paper feed clutch [E] (☛ x 1, 1 bushing, ☛ x 1)

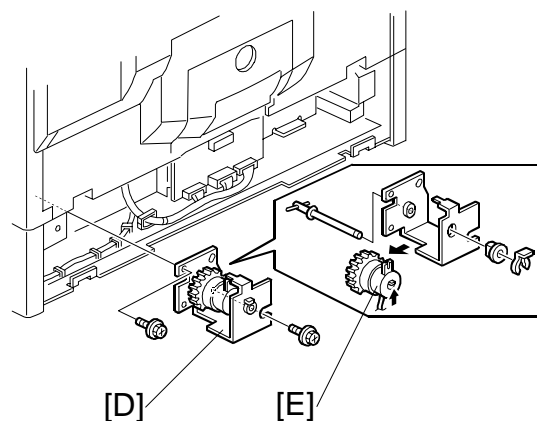

3.8.14 VERTICAL TRANSPORT SENSOR (TWO-TRAY MODELS ONLY)

1. Open the right lower cover.
2. Metal plate [A] (🔩 x 3)
3. Vertical transport sensor [B] (🔌 x 1)

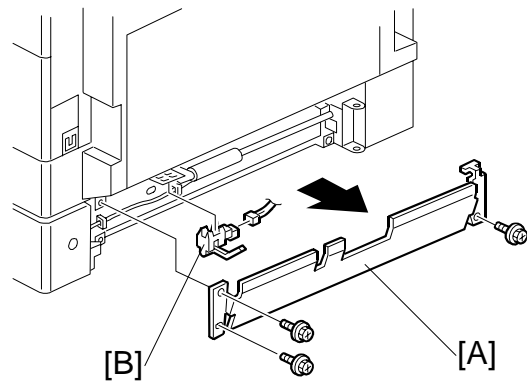

Replacement
Adjustment

3.8.15 PAPER SIZE SWITCH

1. Open the appropriate paper tray.
2. Switch cover [C] (🔩 x 1)
3. Paper size switch [D] (🔌 x 1)

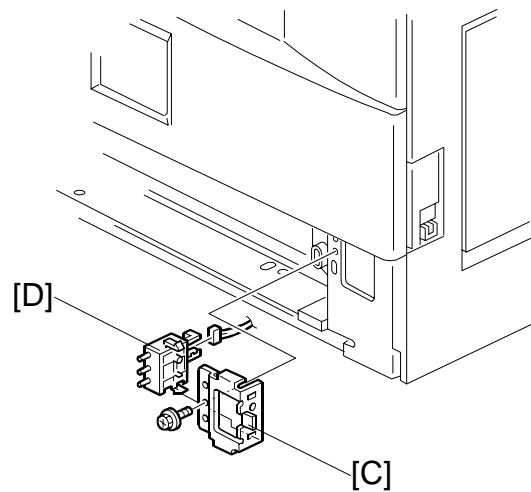

3.9 IMAGE TRANSFER

3.9.1 IMAGE TRANSFER ROLLER

1. Open the right door.
2. Pry open the plastic holders [A] at each end of the roller, and lift off the image transfer roller [B].

NOTE: 1) Leave the springs under the roller in their original position. When replacing the roller, be sure that the pegs [C] on the two square black pieces [D] are facing down into the springs.

- 2) Do not touch the transfer roller surface with bare hands.

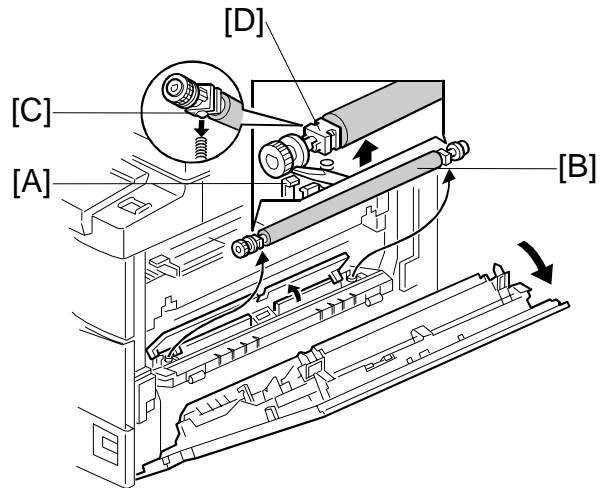

3.9.2 IMAGE DENSITY SENSOR

1. Open the right door.
2. Plastic cover [E]
3. Image transfer roller (☛ 3.9.1)
4. Push down on the notch [F] to free the sensor.
5. Image density sensor [G] (☛ x 1)

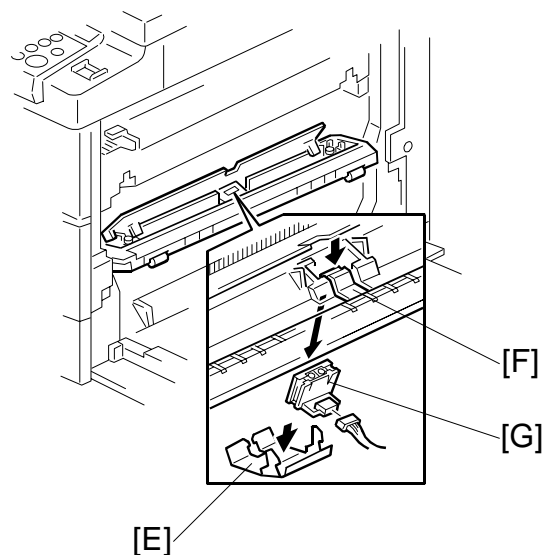

3.10 FUSING

3.10.1 FUSING UNIT

⚠ CAUTION

The fusing unit can become very hot. Be sure that it has cooled down sufficiently before handling it.

1. Turn off the main switch, and unplug the machine.
2. Front right cover (☛ 3.3.10)
3. Open the right door.
4. Fusing unit [A] (⚙ x 2, 📏 x 2)
NOTE: If you forget to connect the small connector when reinstalling, the copier will issue service call SC541.

The color of connector [B]
 Blue: For 120 V machine
 Red: For 230 V machine

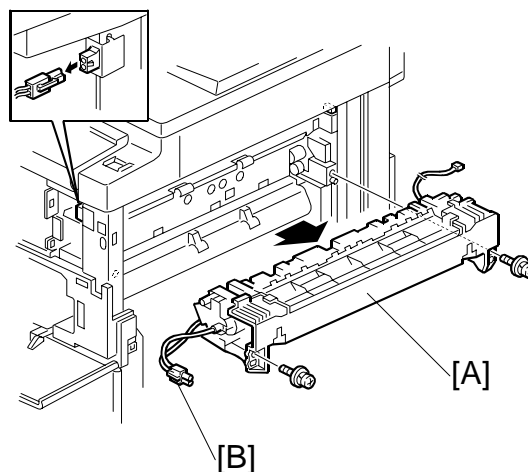

Replacement
Adjustment

3.10.2 THERMISTOR

1. Fusing unit (☛ 3.10.1)
2. Thermistor [C] (⚙ x 1, 📏 x 1)

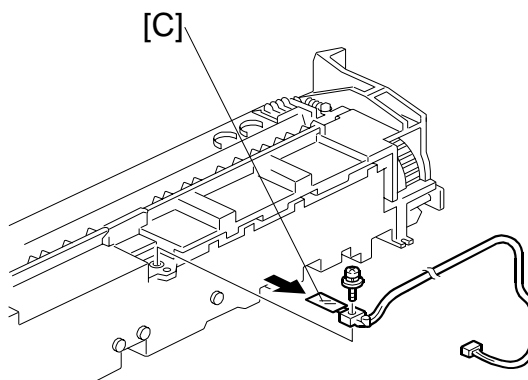

FUSING

3.10.3 FUSING LAMP

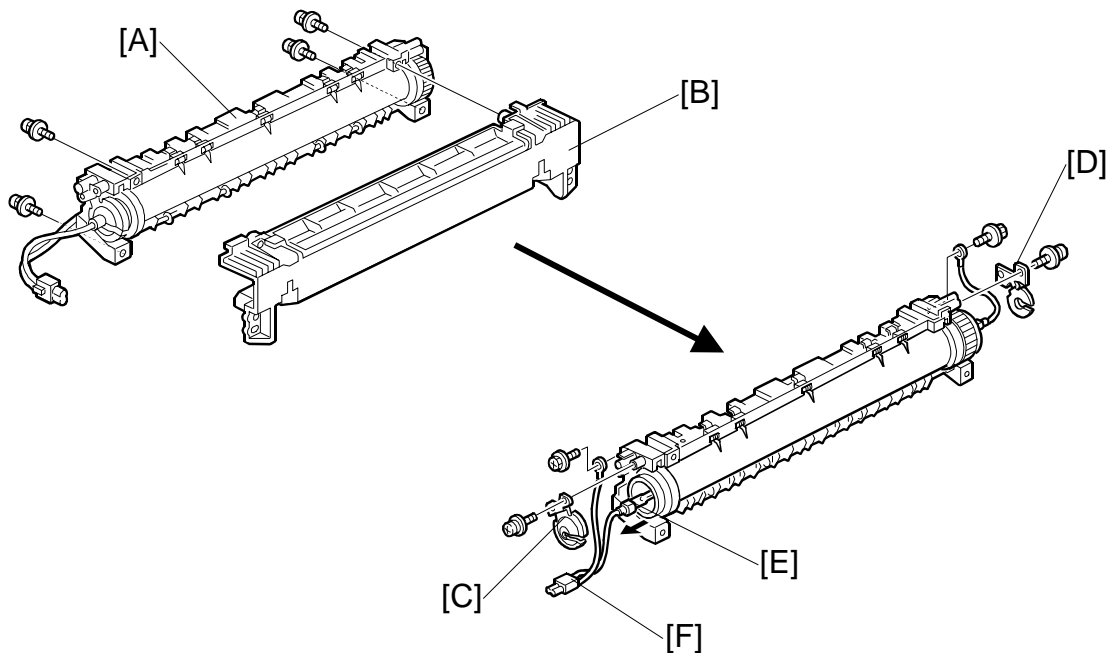

1. Fusing unit (☛ 3.10.1)
2. Separate the fusing unit (☛ x 4) into two sections: the hot roller section [A], and the pressure roller section [B].
3. Front metal holding plate [C] (☛ x 1)
4. Rear metal holding plate [D] (☛ x 1)
5. Remove the fusing lamp [E] from the hot roller section (☛ x 2).

The color of connector [F]
Blue: For 120 V machine
Red: For 230 V machine

3.10.4 HOT ROLLER

1. Fusing lamp (☛ 3.10.3)
2. Hot roller [G] (2 C-rings, 1 gear, 2 bearings)

NOTE: Remove hot roller stripper pawls (☛ 3.10.6) before reinstalling hot cover to avoid scratching the hot roller.

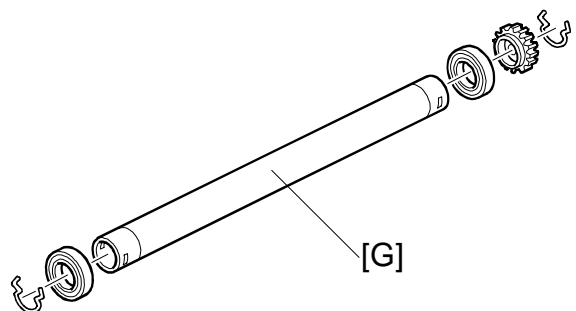

3.10.5 THERMOFUSE AND THERMOSTAT

1. Hot roller (☛ 3.10.4)
2. Thermofuse [A] (☛ x 2)
3. Thermostat [B] (☛ x 2)

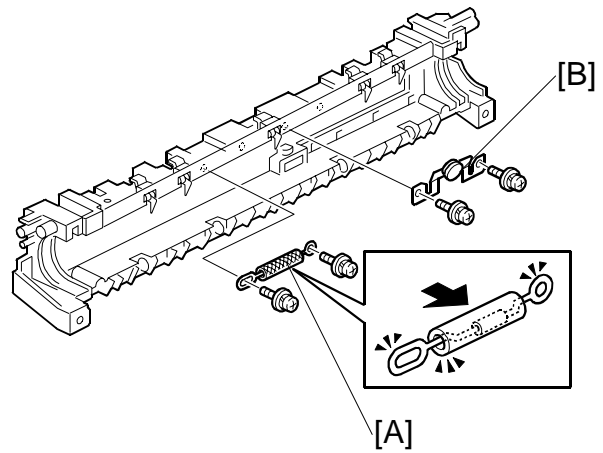

Replacement
Adjustment

3.10.6 HOT ROLLER STRIPPER PAWLS

1. Hot roller (☛ 3.10.4)
2. Metal holders [C] (1 holder for each pawl)
3. Fusing Exit Guide [D]
4. Hot roller stripper pawls [E] (1 spring for each pawl)

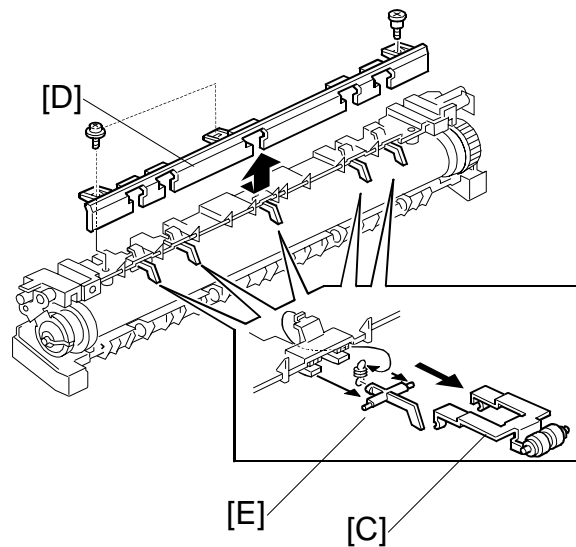

FUSING

3.10.7 PRESSURE ROLLER AND BUSHINGS

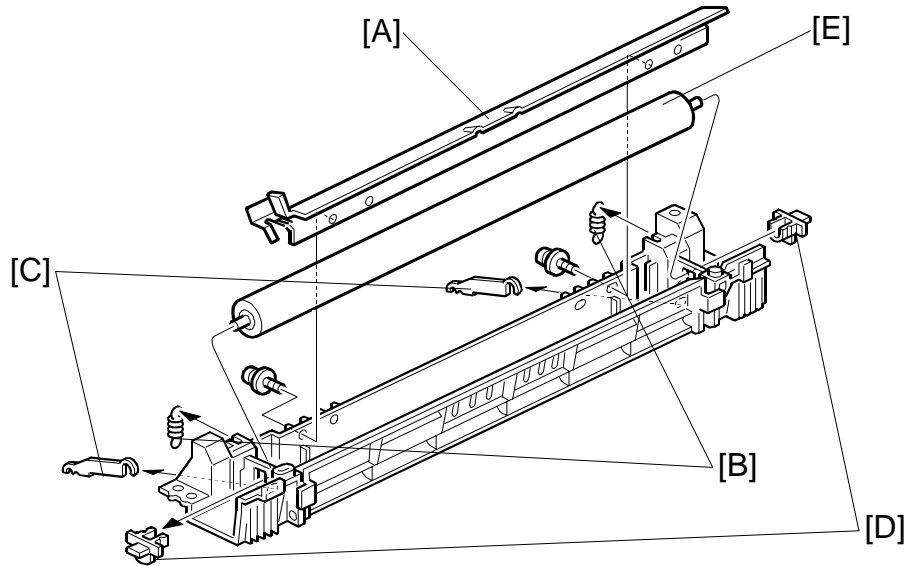

1. Fusing unit (☛ 3.10.1)
2. Separate the fusing unit into two sections: the hot roller section and the pressure roller section (☛ 3.10.3, Step 2). Carry out the remaining steps on the pressure roller section.
3. Fusing entrance guide [A] (☛ x 2)
4. 2 springs [B]
5. 2 pressure arms [C]
NOTE: Manipulate each arm so that it comes out through the slit in the casing.
6. 2 Bushings [D]
7. Pressure roller [E]

3.10.8 NIP BAND WIDTH ADJUSTMENT

- NOTE:** 1) The fusing unit must be at operating temperature when this adjustment is carried out.
- 2) Place an OHP sheet on the by-pass feed table before starting this procedure.
- 3) Use only A4/LT LEF. (Other OHP sheet sizes may cause a paper jam.)

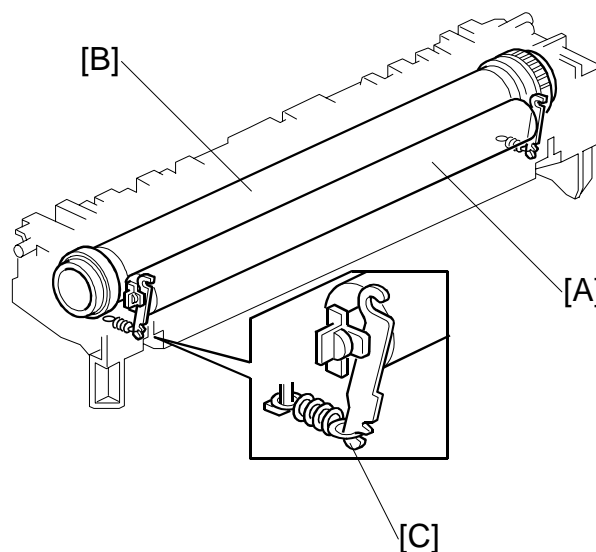

[A]: Pressure roller
[B]: Hot roller

1. Enter SP mode, and run SP1-109.
2. Press . The machine feeds the OHP sheet into the fusing section, stops it there for 20 seconds, then ejects it to the copy tray.
3. Check that the nip band (the opaque stripe) across the ejected OHP sheet is symmetrical, with both ends slightly thicker than the center.
NOTE: There is no standard value for the nip band on this machine. Make the adjustment based on the band's appearance.
4. If the band is not as described above, change the position of the spring hooks [C] (one on each side), and then check the band again.
NOTE: The higher hook position produces greater tension.

3.11 DUPLEX UNIT (DUPLEX MODELS ONLY)

3.11.1 DUPLEX EXIT SENSOR

1. Open the right door.
2. Sensor bracket [A] and bracket [B] (🔩 x 1)
3. Duplex exit sensor [C] (🔩 x 1)

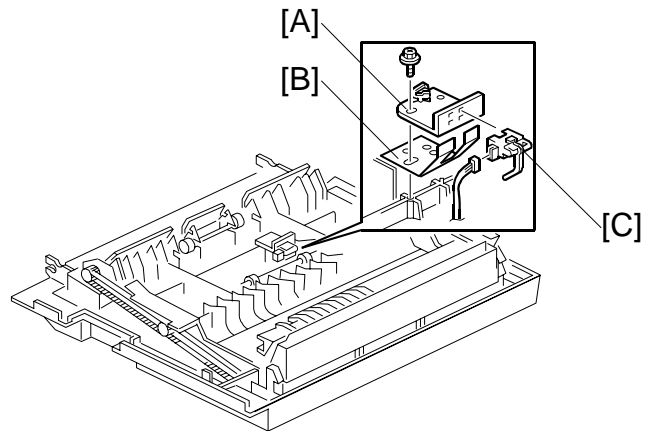

3.11.2 DUPLEX ENTRANCE SENSOR

1. Open the right door.
2. Lift the duplex guide [D].
3. Entrance sensor bracket [E] and bracket cover [F] (🔩 x 2)
4. Duplex entrance sensor [G]

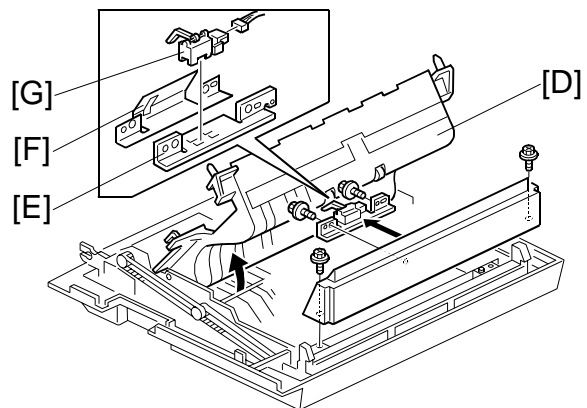

3.11.3 DUPLEX INVERTER SENSOR

1. Open the right door.
2. Sensor bracket [H] (🔩 x 1, 📏 x 1)
3. Duplex inverter sensor [I] (🔩 x 1)

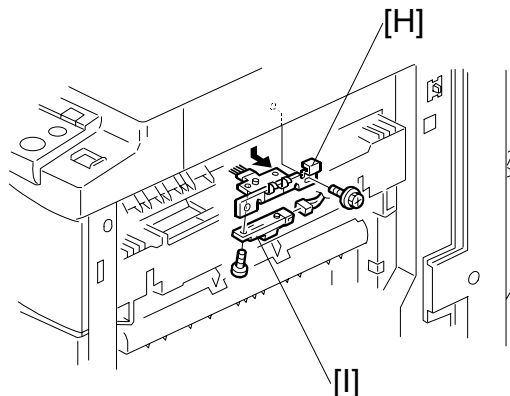

3.11.4 DUPLEX TRANSPORT MOTOR

1. Open the right door, detach the strap from the main body (🔧 x 1), and lower the door.
2. Cover [A] (🔧 x 1)
3. Open the two clamps securing the motor cable, and remove the motor bracket [B] (🔧 x 3, 🛠️ x 1).
4. Remove the duplex transport motor [C] (🔧 x 2).

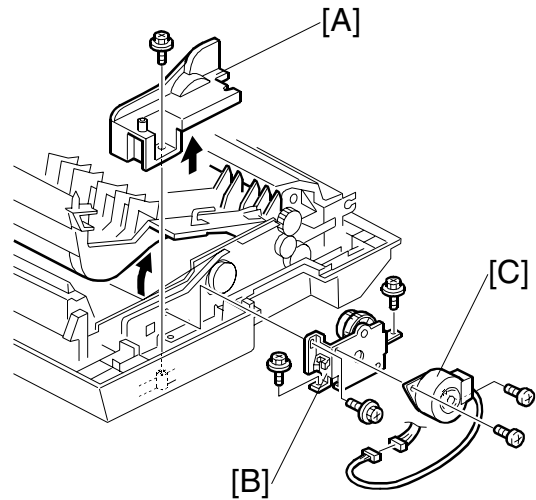

Replacement
Adjustment

3.11.5 DUPLEX INVERTER MOTOR

1. Rear cover
2. Exhaust fan (☛ 3.12.7)
3. Duplex inverter motor [D] (🔧 x 2, 🛠️ x 1)

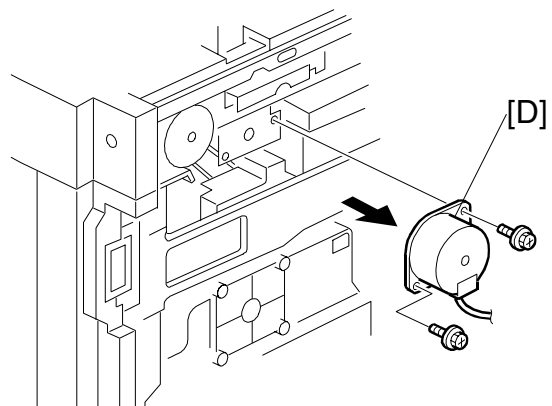

3.11.6 DUPLEX CONTROL BOARD

1. Rear lower cover (☛ 3.3.2)
2. Duplex control board [E] (🔧 x 4, all connectors)

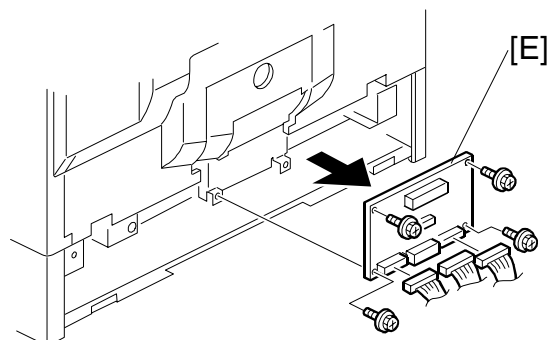

OTHER REPLACEMENTS

3.12 OTHER REPLACEMENTS

3.12.1 QUENCHING LAMP

1. PCU (☛ 3.6.1)
2. Quenching lamp [A] (☛ x 1)

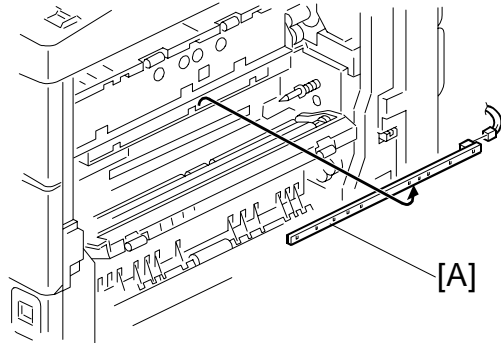

3.12.2 HIGH-VOLTAGE POWER SUPPLY BOARD

1. Rear cover (☛ 3.3.1)
2. High-voltage power supply board [B] (☛ x 3, 2 standoffs, all connectors)

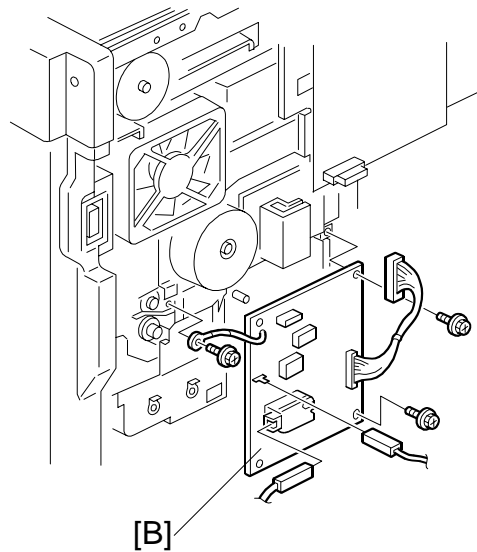

3.12.3 IMB (MEMORY BOARD)

NOTE: The IMB is optional on B039 machines outside North America. It is included as standard equipment on all other models.

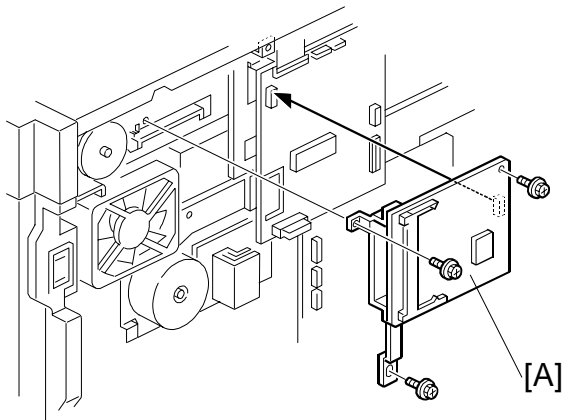

1. IMB (together with bracket) [A]
( x 3)

NOTE: Be sure to remove the bracket together with the IMB. The IMB should never be taken off the bracket. (The IMB and bracket comprise a single service part.)



Replacement Adjustment

3.12.4 BiCU (BASE-ENGINE IMAGE CONTROL UNIT)

1. Rear cover ( 3.3.1)
2. IMB ( 3.12.3)
3. BiCU [B] ( x 6, all connectors, 1 ribbon cable)

NOTE: Reinstall the NVRAM [C] from the old board into the socket on the new board.

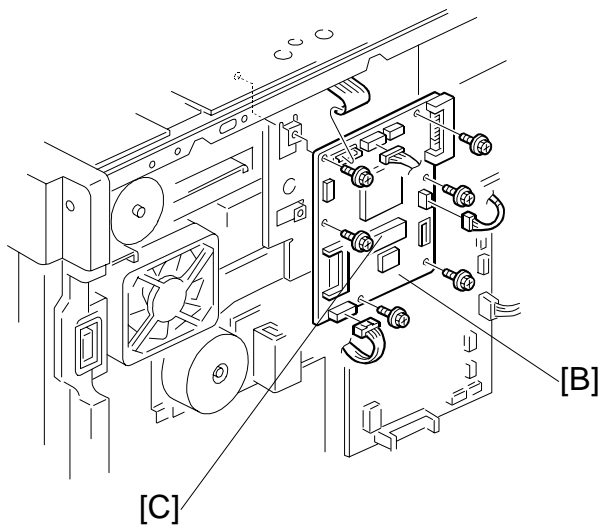



OTHER REPLACEMENTS

3.12.5 IOB (I/O BOARD)

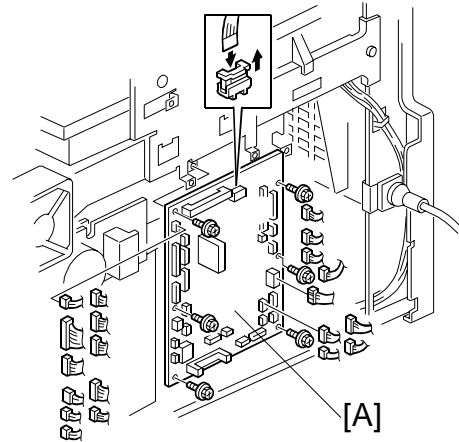
1. BiCU (☛3.12.4)
2. IOB [A] (all connectors,  x 6, 1 ribbon cable)



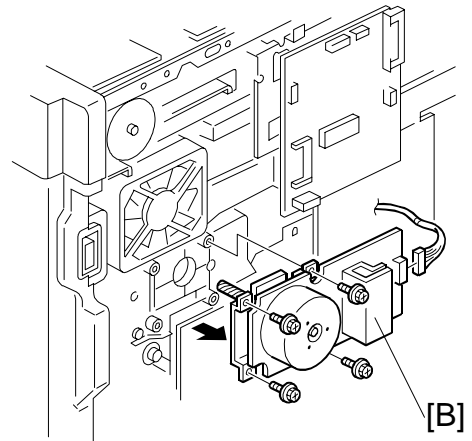

3.12.6 MAIN MOTOR

1. Rear cover (☛ 3.3.1)
2. Main motor [B] ( x 4,  x 1)



3.12.7 REAR EXHAUST FAN

1. Rear cover (☛ 3.3.1)
2. Rear exhaust fan [C] ( x 2,  x 1)

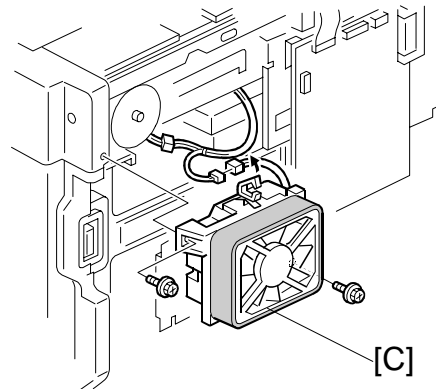

3.12.8 LEFT EXHAUST FAN

1. Rear cover (☛ 3.3.1)
2. Copy tray (☛ 3.3.3)
3. Left cover (☛ 3.3.8)
4. 5 screws [A]
5. Lift up [B], [C] and [D] together and pull the assembly toward the front side of the machine until the hooked harnesses [E] are accessible.
6. Harnesses [E]
7. Remove the [B] from the assembly.
8. Left exhaust fan [F] (🔧 x 2) (🔌 x 1)

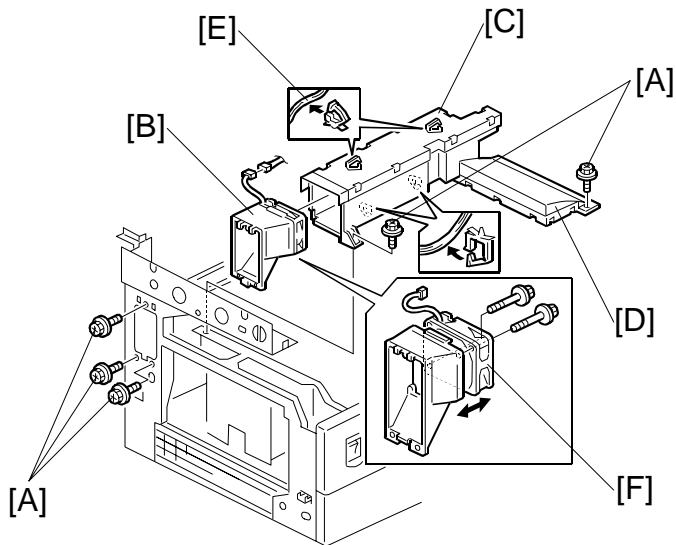

Replacement Adjustment

3.12.9 PSU (POWER SUPPLY UNIT)

1. Left cover (☛ 3.3.8)
2. PSU [G] (all connectors, 🔧 x 6)

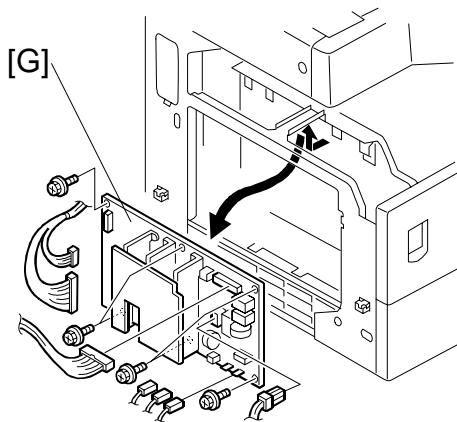

OTHER REPLACEMENTS

3.12.10 GEARBOX

Replacement Procedure

1. BiCU (☛ 3.12.4)
2. BiCU bracket [A] (🔩 x 3)
3. Main motor (☛ 3.12.6)
4. Exhaust fan (☛ 3.12.7)
5. Remove the IOB with bracket (☛ 3.12.5)
6. Crosspiece [B] (🔩 x 4)
7. Registration clutch (☛ 3.8.8)
8. Open the clamp [C] on the gearbox, and take out the wires.
9. Gearbox [E] (🔩 x 5, 1 belt)

NOTE: When reinstalling, set the belt onto the gearbox side first (at [F]), hold it taut, and fit the gearbox into place so that the belt fits over the corresponding gear on the main unit. Handle the gearbox carefully so that the gears don't fall out.

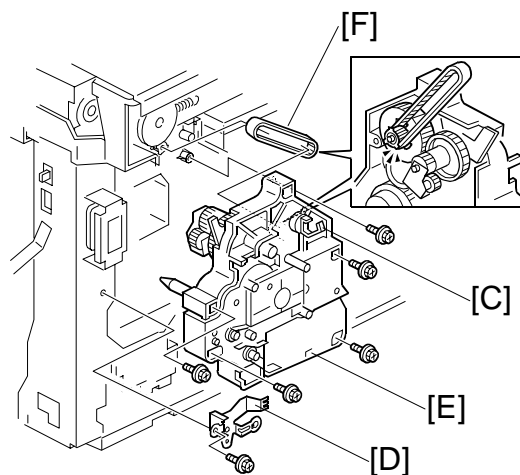
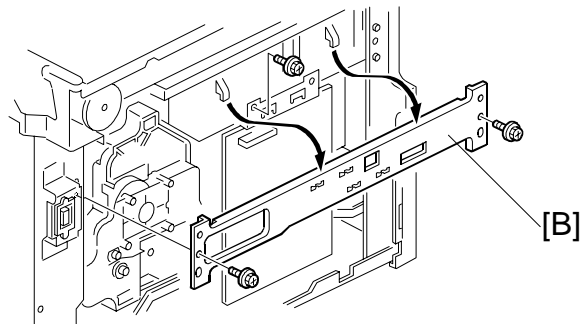
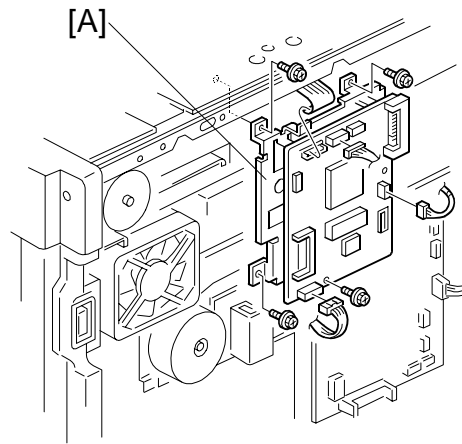

Gear Arrangement Within the Gearbox

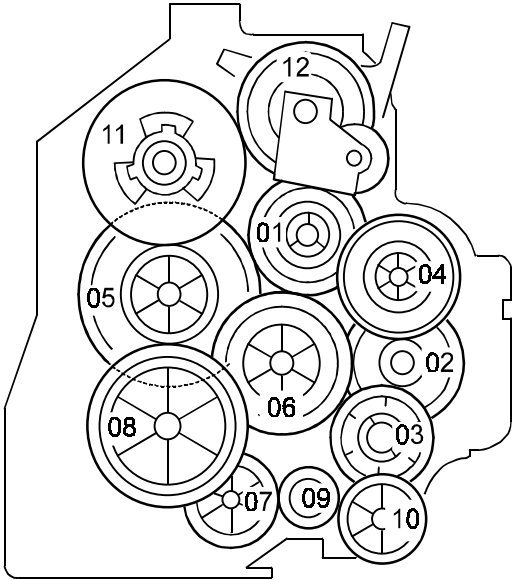

Replacement
Adjustment

The gears are numbered 1 to 12 in the order in which they are to be installed in the gear box. These numbers appear both on the gearbox and on the front (exposed) surface of each gear. If the gears fall out, start by finding gear number 1 and installing it onto location number 1 (setting it into place so that the side with the printed number remains visible). Then install the remaining gears (2 to 12) in the same way.

3.13 COPY ADJUSTMENTS: PRINTING/SCANNING

NOTE: 1) You need to perform these adjustment after executing a Memory All Clear, and after replacing or adjusting any of the following parts.

- First or second scanner
- Lens Block
- Scanner Motor
- Polygonal Mirror Motor
- Paper Tray
- Paper Side Fence

2) For detailed explanations about how to access and use the SP modes, see Section 5.

3.13.1 PRINTING

NOTE: 1) Make sure the paper is installed correctly in each paper tray before you start these adjustments.

2) Use the Trimming Area Pattern (SP5-902, No.10) to print the test pattern for the printing adjustments below.

3) Set SP 5-902 to 0 again after completing these printing adjustments.

Registration - Leading Edge/Side-to-Side

1. Check the leading edge registration for each paper feed station, and adjust each of these registrations using SP1-001.
2. Check the side-to-side registration for each paper feed station, and adjust these registrations using SP1-002. (Adjust the trays in order: the 1st tray first, then the 2nd tray, etc.)

Tray	SP mode	Specification
Any paper tray	SP1-001-1	2 ± 1.5 mm
By-pass feed	SP1-001-2	
Duplex	SP1-001-3	
1st tray	SP1-002-1	2 ± 1.5 mm
2nd tray	SP1-002-2	
3rd tray (Optional PFU tray 1)	SP1-002-3	
4th tray (Optional PFU tray 2)	SP1-002-4	
By-pass feed	SP1-002-5	
Duplex	SP1-002-6	

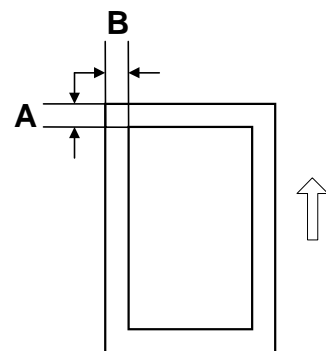

A: Leading Edge Registration
B: Side-to-side Registration

Blank Margin

NOTE: If the leading edge or side-to-side registration cannot be adjusted to within the specification, then adjust the leading-edge blank margin or the left-side blank margin.

1. Check the trailing edge and right side edge blank margins, and adjust them using the following SP modes.

	SP mode	Specification
Trailing edge	SP2-101-2	2 +2.5/-1.5 mm
Right edge	SP2-101-4	2 +2.5/-1.5 mm
Leading edge	SP2-101-1	2 ± 1.5 mm
Left edge	SP2-101-3	2 ± 1.5 mm

- A: Trailing Edge Blank Margin
- B: Right Edge Blank Margin
- C: Leading Edge Blank Margin
- D: Left Edge Blank Margin

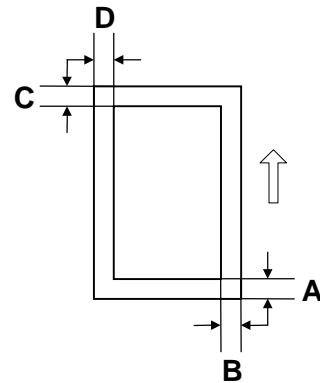

Replacement Adjustment

Main Scan Magnification

1. Print the single-dot grid pattern (SP5-902-5).
2. Check the magnification (the grid size should be 2.7 x 2.7 mm), and if necessary use SP2-998 to adjust it. The specification is 100 ± 1%.

3.13.2 SCANNING

- NOTE:** 1) Before doing the following scanner adjustments, check and adjust the printing leading-edge and side-to-side registrations and the printing blank margins (as described above).
2) Use an S5S test chart to perform the following adjustments.

Registration: Platen Mode

1. Place the test chart on the exposure glass and make a copy from one of the feed stations.
2. Check the leading edge and side-to-side registration, and adjust as necessary using the following SP modes.

	SP mode	Specification
Leading edge	SP4-010	2 ± 1.5 mm
Side-to-side	SP4-011	2 ± 1.5 mm

A: Leading edge registration
B: Side-to-side registration

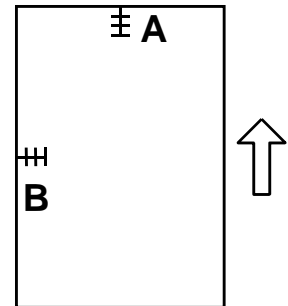

Magnification

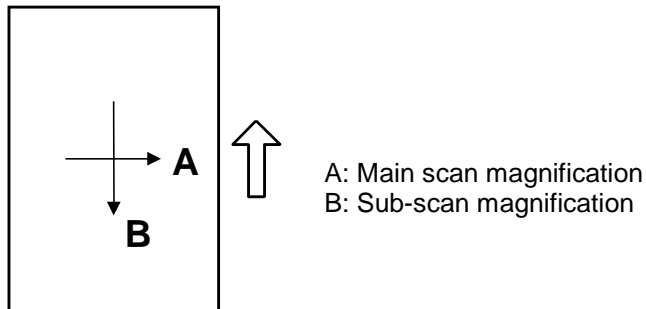

Replacement Adjustment

Main Scan Magnification

1. Place the S5S test chart on the exposure glass and make a copy from one of the feed stations.
2. Check the magnification ratio. If necessary, adjust the magnification using the following SP mode.

	SP mode	Specification
Main Scan Magnification	SP4-008	± 1.0%

Sub-scan Magnification

1. Place the S5S test chart on the exposure glass and make a copy from one of the feed stations.
3. Check the magnification ratio. If necessary, adjust the magnification using the following SP mode.

	SP mode	Specification
Sub-scan magnification	SP4-101	± 1.0%

Standard White Density Adjustment

This procedure adjusts the standard white density level. Carry out this adjustment after doing any of the following:

- After replacing the standard white plate.
- After replacing the NVRAM on the BiCU. (But note that you do not need to carry out this adjustment if you have replaced the BiCU itself but retained the previous NVRAM board [by moving it over onto the new BiCU].)
- After performing a memory all clear (SP5-801).

Procedure:

1. Place 10 sheets of new Letter paper (LEF) or new DLTR paper on the exposure glass, and close the platen cover or the ADF.
2. Enter SP4-908 and select "1: YES". The machine automatically adjusts the standard white density.

3.13.3 ADF IMAGE ADJUSTMENT

Registration and Blank Margin

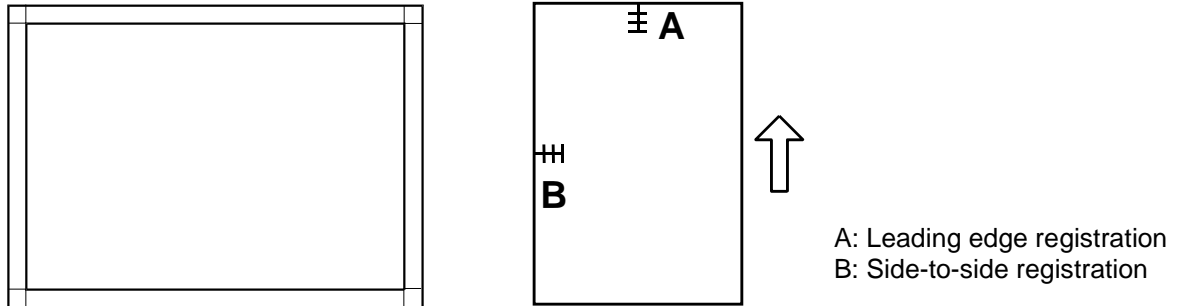

NOTE: Make a temporary test chart as shown above, using A3/11" x 17" paper.

1. Place the temporary test chart on the ADF and make a copy from one of the feed stations.
2. Check the registrations, and adjust as necessary using the appropriate SP modes, as follows.

	SP mode
Side-to-side registration	SP6-006-1
Leading edge registration	SP6-006-2
Blank margin for the trailing edge	SP6-006-3
Side-to-side registration (Duplex: rear)	SP6-006-4

Sub-scan Magnification

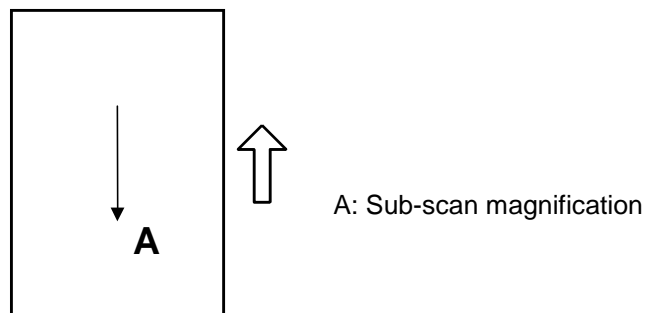

NOTE: Make a temporary test chart as shown above, using A3/11" x 17" paper.

1. Place the temporary test chart on the ADF and make a copy from one of the feed stations.
2. Check the registration, and if necessary adjust it using SP6-007. The specification is $\pm 1.0\%$.

TROUBLESHOOTING

4. TROUBLESHOOTING

4.1 SERVICE CALL CONDITIONS

4.1.1 SUMMARY

There are 2 levels of service call conditions.

Level	Definition	Reset Procedure
A	To prevent the machine from being damaged, the SC can only be reset by a service representative. The copier cannot be operated at all.	Enter SP 5-810 (SC code reset) and select "1". Then hold down the <i>Original type</i> key and the OK or (R/#) key at the same time (this does not require the main switch to be turned off and on).
B	The SC can be reset by turning the main power switch off and on.	Turn the main power switch off and on.

- NOTE:** 1) If the problem concerns electrical circuit boards, first disconnect then reconnect the connectors before replacing the PCBs.
2) If the problem concerns a motor lock, first check the mechanical load before replacing motors or sensors.

SERVICE CALL CONDITIONS

4.1.2 SC CODE DESCRIPTIONS

No. Definition		Symptom	Possible Cause
101	B	Exposure Lamp Error	
		The standard white level was not detected properly when scanning the white plate.	<ul style="list-style-type: none"> • Exposure lamp defective • Exposure lamp stabilizer defective • Exposure lamp connector defective • Dirty scanner mirror or scanner mirror out of position • SBU board defective • SBU connector defective • Lens block out of position • Incorrect position or width of white plate scanning (☛ SP4-015)
120	B	Scanner home position error 1	
		The scanner home position sensor does not detect the off condition during initialization or copying.	<ul style="list-style-type: none"> • Scanner home position sensor defective • Scanner drive motor defective • Scanner home position sensor connector defective • Scanner drive motor connector defective • IOB board defective
121	B	Scanner home position error 2	
		The scanner home position sensor does not detect the on condition during initialization or copying.	<ul style="list-style-type: none"> • Scanner home position sensor defective • Scanner drive motor defective • Scanner home position sensor connector defective • Scanner drive motor connector defective • IOB board defective
122	B	Scanner home position error 3	
		The scanner home position sensor detects the on condition while the scanner is returning to the home position.	<ul style="list-style-type: none"> • Scanner home position sensor defective • Scanner drive motor defective • Scanner home position sensor connector defective • Scanner drive motor connector defective • IOB board defective
123	B	Scanner home position error 4	
		The scanner home position sensor does not detect the on condition after the scanner returns to the home position.	<ul style="list-style-type: none"> • Scanner home position sensor defective • Scanner drive motor defective • Scanner home position sensor connector defective • Scanner drive motor connector defective • IOB board defective

SERVICE CALL CONDITIONS

No. Definition		Symptom	Possible Cause
130	B	Communication Error between BiCU and SBU	
		The BiCU board cannot detect the SBU connect signal.	<ul style="list-style-type: none"> • The flat cable between the BiCU board and the SBU has a poor connection • The flat cable between the BiCU board and the SBU damaged • BiCU board defective • SBU defective
192	B	Automatic SBU adjustment error	
		During the automatic SBU adjustment, the machine detects that the white level read from the white plate or paper is out of range. (☛ SP4-908)	<ul style="list-style-type: none"> • Exposure lamp defective • SBU auto adjustment was not done correctly (☛ 3.13 Copy adjustment printing/scanning – Standard white density adjustment) • SBU defective • BiCU board defective • Exposure lamp stabilizer defective
194	B	SBU White Level Detection Error	
		The automatic SBU adjustment failed twenty times consecutively.	<ul style="list-style-type: none"> • Exposure lamp defective • Dirty white plate • Incorrect position or width of white plate scanning (☛ SP4-015) • BiCU board defective • SBU board defective
302	B	Charge roller current leak	
		A current leak signal for the charge roller is detected.	<ul style="list-style-type: none"> • Charge roller damaged • High voltage supply board defective • Poor connection of the PCU
320	B	Polygonal mirror motor error	
		The polygon mirror motor does not reach operating speed within 10 seconds after the motor ON signal is sent, or does not turn on within one of the 200 ms check intervals during operation.	<ul style="list-style-type: none"> • Polygon mirror motor defective • Poor connection between the polygonal mirror motor driver and the BiCU board • Damaged cable between BiCU/IOB and polygonal mirror motor driver • BiCU board defective
321	B	No laser writing signal (F-GATE) error	
		The laser writing signal (F-GATE) fails to turn Low after the laser crosses 5 mm on the drum surface from the laser writing start position.	<ul style="list-style-type: none"> • BiCU board defective • IMB board defective • The fax controller or printer controller has a poor connection • Fax controller or printer controller defective

Trouble-shooting

SERVICE CALL CONDITIONS

No. Definition		Symptom	Possible Cause
322	B	Laser synchronization error	
		The main scan synchronization detector board cannot detect the laser synchronization signal for more than 5 consecutive 100 ms intervals.	<ul style="list-style-type: none"> • Poor connection between the LD unit and the BICU board • Damaged cable between BiCU and LD unit • LD unit out of position • LD unit defective • BiCU board defective
390	B	TD sensor error	
		The TD sensor outputs less than 0.2 V or more than 4.0 V 10 times consecutively during copying.	<ul style="list-style-type: none"> • TD sensor abnormal • Poor connection of the PCU
391	B	Development bias leak	
		A development bias leak signal is detected.	<ul style="list-style-type: none"> • Poor connection of the PCU • High voltage supply board defective
392	B	TD sensor initial setting error	
		TD sensor initial setting is not performed correctly.	<ul style="list-style-type: none"> • ID sensor defective • No developer • Drum does not turn • Development roller does not turn • Poor connection of the PCU • The voltage is not applied to charge roller
401	B	Transfer roller leak error 1	
		A current leak signal for the transfer roller is detected. A current feedback signal for the transfer roller is not detected.	<ul style="list-style-type: none"> • High voltage supply board defective • Poor connection of the PCU • Transfer/separation unit set incorrectly • Transfer roller damaged
402	B	Transfer roller leak error 2	
		A current leak signal for the transfer roller is detected. A current feedback signal for the transfer roller is not detected.	<ul style="list-style-type: none"> • High voltage supply board defective • Poor connection of the PCU • Transfer/separation unit set incorrectly • Transfer roller damaged
500	B	Main motor lock	
		A main motor lock signal is not detected for more than 7 consecutive checks (700 ms) after the main motor starts to rotate, or the lock signal is not detected for more than 7 consecutive checks during rotation after the last signal.	<ul style="list-style-type: none"> • Too much load on the drive mechanism • Main motor defective
503	B	Upper paper tray lift motor malfunction (optional paper tray units)	
		The paper lift sensor fails to activate twice continuously after the tray lift motor has been on for 18 seconds.	<ul style="list-style-type: none"> • Paper lift sensor defective • Tray lift motor defective • Too much load on the drive mechanism • Poor tray lift motor connection

SERVICE CALL CONDITIONS

No. Definition		Symptom	Possible Cause
504	B	Lower paper tray lift motor malfunction (optional two-tray paper tray unit)	
		The paper lift sensor fails to activate twice continuously after the tray lift motor has been on for 18 seconds.	<ul style="list-style-type: none"> • Paper lift sensor defective • Tray lift motor defective • Too much load on the drive mechanism • Poor tray lift motor connection
506	B	Paper tray motor lock (optional paper tray units)	
		A motor lock signal is not detected for more than 1.5 s or the lock signal is not detected for more than 1.0 s during rotation.	<ul style="list-style-type: none"> • Paper tray unit motor defective • Too much load on the drive mechanism
541	A	Fusing thermostat/thermistor open	
		The fusing temperature detected by the thermistor is below 10°C for 5 seconds after the main power switch is turned on.	<ul style="list-style-type: none"> • Fusing thermostat defective or out of position • Fusing thermistor defective or out of position • Power supply board defective
542	A	Fusing temperature warm-up error	
		The fusing temperature does not reach 80°C within 30 seconds after the main switch is turned on.	<ul style="list-style-type: none"> • Fusing thermistor defective or out of position • Fusing lamp open • Fusing thermostat open • Fusing thermofuse open • Power supply board defective
543	A	Fusing overheat error	
		A fusing temperature of over 230°C is detected for 1 second by the fusing thermistor.	<ul style="list-style-type: none"> • Fusing thermistor defective • Power supply board defective
544	A	Fusing low temperature error	
		A fusing temperature of lower than 100°C is detected for 1 second by the fusing thermistor during operation or stand-by mode.	<ul style="list-style-type: none"> • Fusing lamp open • Fusing thermistor defective • Power supply board defective • Fusing thermistor open • Fusing thermostat open
546	A	Unstable fusing temperature	
		The fusing temperature does not rise 3 °C or more within 5 seconds after the fusing lamp has been on over 8 seconds.	<ul style="list-style-type: none"> • Thermistor defective • Power supply unit defective
547	B	Zero cross signal malfunction	
		Zero cross signals are not detected within 5 seconds after the main power switch is turned on, or are not detected within 1 second after operation begins.	<ul style="list-style-type: none"> • Power supply board defective • IOB defective • BiCU defective
620	B	Communication error between IOB and ADF	
		The IOB does not receive a response from the ADF main board for 4 seconds or more.	<ul style="list-style-type: none"> • Poor connection between the IOB and ADF main board (DF connector) • ADF main board defective • IOB defective

Trouble-shooting

SERVICE CALL CONDITIONS

No. Definition		Symptom	Possible Cause
691	B	Communication error between BiCU and fax controller	
		The BiCU board cannot communicate with the fax controller.	<ul style="list-style-type: none"> • Poor connection between the BiCU board and the fax controller • BiCU board defective • Fax controller defective
692	B	Communication error between BiCU and printer controller	
		The BiCU board cannot communicate with the printer controller.	<ul style="list-style-type: none"> • Poor connection between the BiCU board and the printer controller. • BiCU board defective • Printer controller defective
695	B	Fax firmware error	
		The fax program cannot be started. (☛ Fax Service Manual)	<ul style="list-style-type: none"> • The fax firmware download has not been completed correctly. Try again.
760	B	ADF gate abnormal	
		The ADF Gate signal line between the ADF main board and the IOB is disconnected.	<ul style="list-style-type: none"> • ADF main board defective • Input/output board defective • Poor connection (ADF Gate line) between the ADF main board and the IOB.
900	B	Electrical total counter error	
		The electrical total counter does not work properly.	<ul style="list-style-type: none"> • NVRAM defective
901	B	Mechanical total counter	
		The mechanical total counter does not work properly.	<ul style="list-style-type: none"> • Mechanical total counter defective • IOB defective • Disconnected mechanical total counter
921	B	IMB memory controller error	
		A memory control job is not completed within a certain period.	<ul style="list-style-type: none"> • IMB defective • BiCU defective • Poor connection between IMB and BiCU
922	B	IMB DRAM error	
		The machine detects a discrepancy in the IMB DRAM write/read data during its write/read test (done at power off/on and at recovery from low power or night/off mode).	<ul style="list-style-type: none"> • IMB defective • BiCU defective • Poor connection between BiCU and IMB
924	B	Optional DRAM error	
		The machine detects a discrepancy in the Optional DRAM write/read data during its write/read test (done at power off/on and at recovery from low power or night/off mode).	<ul style="list-style-type: none"> • Non-supported DRAM connected • Poor connection between IMB and optional DRAM • Optional DRAM defective • IMB defective • BiCU defective

SERVICE CALL CONDITIONS

No. Definition		Symptom	Possible Cause
925	B	IMB non-connected error	
		IMB is not connected. This SC only appears with B040 and B043 version machines.	<ul style="list-style-type: none"> • IMB is not connected • Poor connection between BiCU and IMB • IMB defective • BiCU defective
926	B	Memory capacity error	
		The machine detects a discrepancy between the memory capacity detected during the memory check at power on and the check at recovery from low power or night/off mode.	<ul style="list-style-type: none"> • Poor connection between optional DRAM and IMB • Optional DRAM defective • IMB defective • BiCU defective
981	B	NVRAM error	
		The machine detects a discrepancy in the NVRAM write/read data when attempting to save actual data to the NVRAM (i.e. during actual use).	<ul style="list-style-type: none"> • NVRAM defective • Poor connection between BiCU and NVRAM • NVRAM is not connected • BiCU defective
990	B	Communication error between BiCU and IOB	
		The BiCU board cannot communicate with the IOB.	<ul style="list-style-type: none"> • The connection between the BiCU board and the IOB is poor. • BiCU board defective • IOB defective
999	B	Program version error	
		An incorrect type of main software was downloaded.	<ul style="list-style-type: none"> • The main software for another machine was downloaded to this machine. Switch the machine off. Connect an IC card that has the correct firmware to the machine. Switch the machine on, and download the firmware. (☛ 5.1.9)

Trouble-shooting

4.2 ELECTRICAL COMPONENT DEFECTS

4.2.1 SENSORS

Component	CN	Condition	Symptom
Registration	312-2 (IOB)	Open	The Paper Jam message will appear whenever a copy is made (paper hasn't reached the sensor).
		Shorted	The Paper Jam message appears even if there is no paper at the sensor.
Upper Relay	312-5 (IOB)	Open	The Paper Jam message will appear whenever a copy is made except for 1st and by-pass tray feeding.
		Shorted	The Paper Jam message appears even if there is no paper at the sensor.
Upper Paper End	314-2 (IOB)	Open	The Paper End indicator lights when the 1st paper tray is selected, even if there is paper in the tray.
		Shorted	The Paper End indicator does not light when the 1st paper tray is selected, even if there is no paper in the tray. The Paper Jam message will appear whenever a copy is made from the 1st paper tray.
Lower Vertical Transport	316-2 (IOB)	Open	The Paper Jam message will appear whenever a copy is made from an optional paper tray unit.
		Shorted	The Paper Jam message appears even if there is no paper at the sensor.
Lower Paper End	317-6 (IOB)	Open	The Paper End indicator lights when the 2nd paper tray is selected, even if there is paper in the tray (B040/B043 models only).
		Shorted	The Paper End indicator does not light when the 2nd paper tray is selected, even if there is no paper in the tray. The Paper Jam message will appear whenever a copy is made from the 2nd paper tray (B040/B043 models only).
By-pass Paper Size	311-1,2,4,5 (IOB)	Open	The CPU misdetects or is not able to detect the size of the paper set in the bypass tray, causing possible misfeeds when feeding from this tray.
		Shorted	
By-pass Paper End	311-7 (IOB)	Open	The Paper End indicator lights when the bypass tray is selected, even if there is paper in the tray.
		Shorted	The Paper End indicator does not light when the bypass tray is selected, even if there is no paper in the tray. The Paper Jam message will appear whenever a copy is made from the bypass tray.
Exit	331-2 (IOB)	Open	The Paper Jam message will appear whenever a copy is made (paper hasn't reached the sensor).
		Shorted	The Paper Jam message appears even if there is no paper at the sensor.
Toner Density	325-3 (IOB)	Open	SC390 is displayed.
		Shorted	

ELECTRICAL COMPONENT DEFECTS

Component	CN	Condition	Symptom
Image Density	326-2 (IOB)	Open	The toner density control process is changed (see the note below the table).
		Shorted	
Scanner H.P.	304-2 (IOB)	Open	SC120 is displayed.
		Shorted	
Platen Cover	304-5 (IOB)	Open	APS and Auto Reduce/Enlarge do not function correctly.
		Shorted	If the Start button is pressed with the platen cover or A(R)DF closed, "Cannot detect original size" is displayed.
Original Width	305-3,4 (IOB)	Open	The CPU cannot detect the original size properly. APS and Auto Reduce/Enlarge do not function correctly.
		Shorted	
Original Length	305-8,9 (IOB)	Open	The CPU cannot detect the original size properly. APS and Auto Reduce/Enlarge do not function correctly.
		Shorted	
Duplex Entrance	222-2 (DCB)	Open	The Paper Jam message will appear whenever a duplex copy is made (paper hasn't reached the sensor).
		Shorted	The Paper Jam message appears even if there is no paper at the sensor.
Duplex Exit	222-5 (DCB)	Open	The Paper Jam message will appear whenever a duplex copy is made (paper hasn't reached the sensor).
		Shorted	The Paper Jam message appears even if there is no paper at the sensor.
Duplex Inverter	220-6 (DCB)	Open	The Paper Jam message will appear whenever a duplex copy is made (paper hasn't reached the sensor).
		Shorted	The Paper Jam message appears even if there is no paper at the sensor.

NOTE: SC392 is activated when the CPU detects an ID sensor error during developer initialization (SP2-214). However, SC392 is not displayed on the LCD but simply logged in the SC log (SMC printout), unless the technician exits SP Mode as soon as the "Error!!!" message is displayed.

4.2.2 SWITCHES

Component	CN	Condition	Symptom
Upper Paper Size	315 1,2,4 (IOB)	Open	The CPU cannot detect the proper paper size, and misfeeds may occur when a copy is made from the 1st paper tray.
		Shorted	
Vertical Transport Door	316-5 (IOB)	Open	The Cover Open indicator is lit even if the vertical transport door is closed.
		Shorted	The Cover Open indicator is not lit even if the vertical transport door is opened.
Lower Paper Size	317- 1,2,4 (IOB)	Open	The CPU cannot detect the proper paper size, and misfeeds may occur when a copy is made from the 2nd paper tray.
		Shorted	

BLOWN FUSE CONDITIONS

Component	CN	Condition	Symptom
Right Door	331-5 (IOB)	Open	The Cover Open indicator is lit even if the right door is closed.
		Shorted	The Cover Open indicator is not lit even if the right door is open.
Front/Right Cover	328-1 (IOB)	Open	The Cover Open indicator is lit even if doors are closed.
		Shorted	The Cover Open indicator is not lit even if doors are open.
Main	281-3,4 (PSU)	Open	The machine does not turn on.
		Shorted	The machine does not turn off.

4.3 BLOWN FUSE CONDITIONS

Fuse	Rating		Symptom when turning on the main switch
	120 V	220 – 240 V	
Power Supply Board			
FU1	15 A/125 V	—	No response.
FU2	6.3 A/250 V	3.15 A/250 V	No response.
FU3	2 A/125 V	2 A/250 V	Anti-condensation/Tray Heater does not turn on.
FU4	4 A/125 V	4 A/250 V	Optional peripheral(s) are detected but do not function.
FU5	4 A/125 V	4 A/250 V	The Cover Open indicator is lit then SC901 is displayed.
FU6	3.15 A/125 V	3.15 A/250 V	LEDs are not lit and the LCD display does not function (backlight only).

4.4 LED DISPLAY

4.4.1 BiCU

Number	Function
LED 1	Monitors the +5 V line for the CPU and the surrounding circuit. Usually, this LED is blinking.
LED 2	Monitors the +5 V line. Usually, this LED is lit.

4.4.2 IOB

Number	Function
LED301	Monitors the connection between the IOB and the BiCU. Usually, this LED is blinking.

4.5 FIRMWARE HISTORY

4.5.1 B040 FIRMWARE MODIFICATION HISTORY

DESCRIPTION OF MODIFICATION	FIRMWARE LEVEL	SERIAL NUMBER	FIRMWARE VERSION
<p>⇒ Corrects the following:</p> <ol style="list-style-type: none"> 1. Black lines in halftone areas. 2. Software modified so that no transfer current can be applied to the development roller surface after the main motor has stopped 3. Change in detection conditions: To reduce (unnecessary) occurrences of SC350/392, the detection conditions have been changed as follows: <ol style="list-style-type: none"> 1) TD sensor 4V adjustment error must occur twice (check cycle is repeated). 3) Allowable interval (4V adjustment). Changed from 80ms to 100ms. 4. If a tray (optional tray unit) is installed but not fully pushed in when the main power is turned on, there is no status display at all for that tray. 5. Specification change: If the Copy Reset Timer is set to "off", the Program User Code and Change User Code screens (Copy Features - Key Operator Tools) will not be cleared once the operator has started code input. Note: If enabled, the Energy Saver Timer and System Reset Timer will reset the screen (same as before) 6. Specification change: The key counter will not count up when the Printer Counter List is printed out. 7. When performed, SP7-808 (Reset Counters) would mistakenly clear the Copy, Fax, Printer, Duplex and A3/DLT counters. Note: This error did not affect (clear) the Total or Timer counters 8. Despite key counter user restrictions, it is always possible to print out faxes. In addition, faxes are not recorded by the key counter (only by the total counter). 9. The Start Key does not turn green after the original scanning memory becomes full and the remaining originals are re-set for the next scanning (cannot continue). *Conditions: SP5-940 (Image Rotation) = 1 (disabled). Rotation Sort is selected An even # of sets is programmed. <p>Continued</p>	<p>B0395531 A</p>	<p>1st Mass Production</p>	<p>1.10</p>

Trouble-shooting

DESCRIPTION OF MODIFICATION	FIRMWARE LEVEL	SERIAL NUMBER	FIRMWARE VERSION
<p>10. . In Text mode, Background Removal does not completely remove the background surrounding light text characters (e.g. text written in pencil).</p>			
<p>⇒ Corrects the following: When Special Mode (envelopes) is selected, the value for the paper slack set in SP1-003 (Paper Feed Timing) is increased by 5mm.</p> <p>When SP4-942 (Black Line Erase) is set to "2", the image appears split into several horizontal lines.</p> <p>Specification change: Firmware modified so that even when the machine is in the middle of a Key Counter copy job, incoming fax or printer jobs will be accepted.</p> <p>The setting options for SP4-942 have been changed as follows: Old: New: 0: none 0: none 1: weak 1: weak 2: normal 2: strong 3: strong</p> <p>Therefore, the level of the old "1: weak" is the same as the new "2: normal".</p> <p>Specification change: As a countermeasure for fuzzy image borders, the transfer current for Special Mode (envelopes) and for the 2nd side of Duplex prints has been changed.</p>	<p>B0395531 B</p>	<p>June 2001 Production</p>	<p>1.14</p>
<p>⇒ Corrects the following: SC123 sometimes occurs when fax transmission is initiated while the machine is receiving.</p> <p>The following message, which pops up inside User Tools when the # and Start Key are pressed, remains displayed even when the user exits by pressing the User Tools key: "Press Ok to return the copier settings to default. If not, press cancel."</p> <p>In the middle of a combine copy job (exposure glass), the "Set Next + Start ..." message is not re-displayed following the brief error message triggered by the user entering a copy quantity that exceeds the maximum limit</p> <p>After clearing an image rotation DF jam, the copy taken with the exposure glass contains an "Obi" image (a thick, belt-like banding pattern) along with highly reduced copies of the original. Settings: APS, 50% redctn., 3 originals (A3).</p>	<p>B0395531 D</p>	<p>June 2001 Production</p>	<p>1.23</p>

DESCRIPTION OF MODIFICATION	FIRMWARE LEVEL	SERIAL NUMBER	FIRMWARE VERSION
When turning on/off main switch during the combine copy, SC 922 may appear.	B0395531 D	June 2001 production	1.23
The range of the value for SP1-105 has been changed as follows (Service Manual is correct): OLD: 160 ~ 230 °C NEW: 160 ~ 190 °C			
The message when trying to sort by using long length original has been changed as follows: OLD: Cannot Sort This Size Paper NEW: Cannot Sort This Paper Size			
The message when trying to make a duplex copy by using 51/2"x81/2" paper size has been changed as follows: OLD: Cannot Duplex Copy / This Size Paper NEW: Cannot Duplex Copy / This Paper Size			
Corrects the following: The default value for SP2-101-002 (Erase Margin Adjustment - Leading edge) has been changed from 4.0 to 3.0.	B0395531 E	Oct. 2001 Production	1.30
The default value for SP2-101-001 (Erase Margin Adjustment - Leading edge) has been changed from 3.0 to 2.0.			
After SP2-995 (ID Sensor Detection Interval) is set to 256 or higher, the incorrect value is displayed.			
⇒ Corrects the following: When the machine exits Low Power Mode, the Paper End LED may not turn on even when there is no paper remaining. This occurs when the customer has selected Printer as the preferential application.	B0395531 F	April. 2002 Production	1.32
The cooling fan sometimes does not stop when the machine enters Night/Off Mode from the Low Power Mode Level 1.			

Trouble-shooting

SERVICE TABLES

5. SERVICE TABLES



5.1 USING SERVICE PROGRAM MODES

Use the service program modes (SP modes) to check electrical data, change operating modes, and adjust values.

Accessing SP Modes

How to Enter SP Mode

1. Key in the following sequence.

 → **1** → **0** → **7** → 

- Hold the  key down for longer than 3 seconds.
2. The LCD displays a menu of the SP modes.

```
[Service P-Mode] No._
1 Copy 2 Fax 3 Printer
```

NOTE: Installed applications appear on the menu as follows: “1.Copy”, “2. Fax”, “3. Printer”, If an application is not installed, the corresponding item does not appear.



3. Press the number for the application mode you need. (For example, press “1” to select the copier application mode.) The selected SP mode display appears on the LCD, as shown.

```
SP B0395533A EU Class1
No.1 Feed
```

How to Exit SP Mode

Press  or *Cancel* key one or more times to return to the standby-mode display.



Accessing Copy Mode from within an SP Mode

1. Press the  key.
2. Select the appropriate copy mode and make trial copies.
NOTE: The *User Tools* key LED is blinking at this time.
3. To return to SP mode, press the  key.

How to Select a Program Number

```
C1(1)Feed    C2 105
Fusing Temp Adjustment *
```

Each program number consists of two or three levels (“classes”). To select a program, you need to enter each class number in sequence.



1. Enter the first-class program number with the numeric keypad (or change the number using the *Right* or *Left* cursor key), and then press the  key or the *OK* key.
2. Select the second-class program number with the numeric keypad (or *Right* or *Left* cursor key), and press  or *OK*.
3. To select a third-class program (if there are any): select the second-class number and then use the *Right* or *Left* cursor key.
4. To return to the next higher class, press .

NOTE: 1) If the screen is not large enough to display information about all of the available selections, the screen displays a solid semicircle mark as shown below. The mark means that you can press the *Darker* key to view the contents for each selection.
2) An asterisk (*) to the right of mode name indicates that its value has been changed from the default.

```
SMC Printing
(1 - 5)  0
```

To Input a Value or Setting for an SP Mode

1. Enter the required program mode as explained above.
2. Enter the required setting using the numeric keys, and then press  or the *OK* key.

NOTE: 1) If you forget to press  or *OK*, the previous value remains in effect.
2) If necessary, use the  key to select “+” or “-” before entering the value.

5.1.1 SP MODE TABLES

NOTE: In the Function/[Setting] column:



- The related pop-up screen name and function name (if any) appear in parenthesis following the function description.
- Comments are in *italics*.
- The setting range is enclosed in brackets, with the default setting written in **bold**.
- An asterisk (*) after the mode number means that this mode's value is stored in the NVRAM. If you do a RAM reset, all these SP modes will be returned to their factory settings.
- **DFU** stands for **D**esign/**F**actory **U**se only. Values marked **DFU** should not be changed.
- **IAJ** means that you should refer to "Replacement and Adjustment – Copy Image Adjustments" for more information.

SP1-XXX (Feed)

1	Mode Number/Name	Function/[Setting]
001*	Leading Edge Registration	
	1	Paper tray
	2	By-pass
	3	Duplex
		Adjusts the printing leading-edge registration from each paper feed station, using the Trimming Area Pattern (SP5-902, No.10). [-9.0 ~ 9.0 / 0.0 / 0.1 mm/step] IAJ • <i>Specification: 2 ± 1.5 mm</i> • <i>Use the $\odot^{(*)}$ key to select "+" or "-" before entering the value.</i>
002*	Side-to-Side Registration	
	1	1st tray
	2	2nd tray
	3	3rd tray
	4	4th tray
	5	By-pass feed
	6	Duplex
		Adjusts the printing side-to-side registration from each paper feed station, using the Trimming Area Pattern (SP5-902, No.10). Adjustments are supported for all 4 possible feed trays (including optional trays). [-9.0 ~ 9.0 / 0.0 / 0.1 mm/step] IAJ • <i>Specification: 2 ± 1.5 mm</i> • <i>The SP1-002-1 setting is applied to <u>all trays</u>, not just the 1st Tray. Settings for trays 2 to 4 are offsets relative to the SP1-002-1 setting.</i> • <i>For duplex copies, the value for the front side is determined by SP1-002-1 to -4, and the value for the rear side is determined by SP1-002-6.</i> • <i>Use the $\odot^{(*)}$ key to select "+" or "-" before entering the value.</i>
003*	Paper Feed Timing	
	1	1st tray
	2	2nd, 3rd, 4th trays
	3	By-pass feed
	4	Duplex
		Adjusts the amount of buckle the paper feed clutch applies to the paper after the registration sensor is activated. A higher setting applies greater buckling. [0 ~ 10 / 5 / 1 mm/step] [0 ~ 20 / 6 / 1 mm/step]

Service Tables

USING SERVICE PROGRAM MODES

1	Mode Number/Name	Function/[Setting]
007	By-pass Paper Size Display	Displays the by-pass paper width sensor output. Press  to exit the display.
103*	Fusing Idling	Selects whether or not fusing idling is performed. [0 = No / 1 = Yes] <i>Normally disabled in this machine. However, enable this mode if fusing is incomplete on the 1st and 2nd copies, which may occur if the room is cold.</i> ☛ 6.13.5 Fusing Temperature Control
105*	Fusing Temperature Adjustment	
	1 Stand-by	Adjusts the fusing temperature for standby mode. [160 ~ 190 / 175 / 1°C/step]
	2 Low power level 2	Adjusts the fusing temperature for low power level 2. [0 ~ 100 / 60 / 1°C/step] <i>Lower values cause the machine to take a longer time to reach the ready condition.</i>
106	Fusing Temperature Display	Displays the fusing temperature. Press  to exit the display.
107*	Fusing Soft Start Adjustment	
	1 Stand-by	Adjusts the number of zero-cross cycles of the fusing lamp AC supply needed to bring the fusing lamp power to 100% while bringing the lamp up to the standby temperature. Increase this value if the machine is experiencing sudden power dropouts. [North Am.: 0 = 3 cycles / 1 = 10 cycles / 2 = 20 cycles] [EU/Asia: 0 = 3 cycles / 1 = 10 cycles / 2 = 20 cycles] ☛ 6.13.5 Fusing Temperature Control
	2 Copying	Adjusts the number of zero-cross cycles for the fusing lamp AC supply needed to gradually raise the fusing lamp power to 100% during printing. Increase this value if the machine is experiencing sudden power dropouts. [North Am.: 0 = 3 cycles / 1 = 10 cycles / 2 = 20 cycles] [EU/Asia: 0 = 3 cycles / 1 = 10 cycles / 2 = 20 cycles] ☛ 6.13.5 Fusing Temperature Control
108*	Fusing Soft Start Setting	Selects whether the fusing temperature control cycle is 1 second or 3 seconds. [0 = 1 / 1 = 3 s] <i>Setting this item to "1" (3 s) reduces the power supply fluctuation that occurs when the fusing lamp switches on.</i> ☛ 6.13.5 Fusing Temperature Control
109	Fusing Nip Band Check	Checks the fusing nip band. [1 = Start / 0 = Stop] IAJ
902	AC Frequency Display	Displays the fusing lamp power control frequency (as detected by the zero cross signal generator). <i>The displayed value is 1/5 the actual frequency: 10 = 50 Hz, 12 = 60 Hz.</i>

USING SERVICE PROGRAM MODES

1	Mode Number/Name	Function/[Setting]
903*	Feed Clutch Boost	
	1	By-pass tray Adjusts the amount of extra push that the feed clutch gives to the paper after the skew has been corrected at registration. <u>[0 ~ 10 / 6 / 1 mm/step]</u> <i>This feature helps the registration roller feed certain types of paper (such as thick paper). Increase the value if thick paper is jamming after feeding from the registration roller.</i>
	2	2nd, 3rd, 4th tray <u>[0 ~ 10 / 3 / 1 mm/step]</u>
908*	Paper Tray Adjustment	
	1	1st optional Adjusts the reverse time for the upper and lower paper lift motors. <u>[-2 ~ +2 / 0 / 1/step]</u> ☛ <i>Detailed Descriptions – Optional Paper Tray Unit</i>
	2	2nd optional

SP2-XXX (Drum)

2	Mode Number/Name	Function/[Setting]
001*	Charge Roller Bias Adjustment	
1	Printing	Adjusts the voltage applied to the charge roller when printing. [<u>-2100 ~ -1500 / -1700 / 1 V/step</u>] <i>The actually applied voltage changes automatically as charge roller voltage correction is carried out. The value you set here becomes the base value on which this correction is carried out.</i>
2	ID sensor pattern	Adjusts the voltage applied to the charge roller when generating the Vsdp ID sensor pattern (as part of charge roller voltage correction). [<u>0 ~ 400 / 300 / 1 V/step</u>] <i>The actual charge-roller voltage is obtained by adding this value to the value of SP2-001-1.</i>
101*	Erase Margin Adjustment	
1	Leading edge	Adjusts the leading edge erase margin. [<u>0.0 ~ 9.0 / 2.0 / 0.1 mm/step</u>] IAJ <i>Specification: 2 ± 1.5 mm (Have Engine Firmware 1.30 or Newer)</i>
2	Trailing	Adjusts the trailing edge erase margin. The rear trailing edge is this value plus 1.2 mm. [<u>0.0 ~ 9.0 / 4.0 / 0.1 mm/step</u>] IAJ <i>Specification: 2 +2.5/-1.5 mm (Have Engine Firmware 1.30 or Newer)</i>
3	Left side	Adjusts the left edge erase margin. The rear left edge is this value plus 0.3 mm. [<u>0.0 ~ 9.0 / 2.0 / 0.1 mm/step</u>] IAJ <i>Specification: 2 ± 1.5 mm</i>
4	Right side	Adjusts the right edge erase margin. The rear right edge is this value plus 0.3 mm. [<u>0.0 ~ 9.0 / 2.0 / 0.1 mm/step</u>] IAJ <i>Specification: 2 +2.5/-1.5 mm</i>
201*	Development Bias Adjustment	
1	Printing	Adjusts the voltage applied to the development roller when printing. [<u>-1500 ~ -200 / -650 / 1 V/step</u>] <i>This can be adjusted as a temporary measure if faint copies are being produced due to an aging drum.</i>
2	ID sensor pattern	Adjusts the voltage applied to the development roller when generating the ID sensor pattern. [<u>-2 = LL (220 V) / -1 = L (260 V) / 0 = N (300 V) / 1 = H (340 V) / 2 = HH (380 V)</u>] <i>The actual voltage applied is this setting plus the value of SP2-201-1. The setting affects ID sensor pattern density, which in turn affects the toner supply.</i>



USING SERVICE PROGRAM MODES

2	Mode Number/Name	Function/[Setting]						
213*	Outputs after Near End	<p>Sets the number of copy/print/fax pages that can be made after toner near-end has been detected. [0 = 50 pages / 1 = 20 pages] <i>Reduce the number of pages if the user normally makes copies with a high image ratio.</i></p>						
214	Developer Initialization	<p>Initializes both the TD sensor toner supply target voltage and the TD sensor gain value. [0 = No / 1 = Yes] <i>Carry this out after replacing the developer or the TD sensor.</i></p>						
220	TD Sensor Output Value Display	<p>Displays: a) Vt: the current TD sensor output value and b) Vref: the target TD output value Vts (SP2-926) + correction for ID sensor output.</p> <p><i>The TD sensor output value changes every copy. If a > b, toner is supplied to the development unit.</i></p> <p>Press  to exit the display.</p>						
221	ID Sensor Error Analysis	<p>Displays Vsg, Vsp, Vsdp, Vt, and ID sensor input value. Use these values to check the operational status of the ID sensor. [0 = No / 1 = Yes]</p> <ul style="list-style-type: none"> • This machine has no SC code for ID sensor errors. If imaging problems occur (such as dirty background), use this SP to determine whether the problem is with toner density control. • You can use SP7-911 to check the number of ID sensor errors that have occurred. <p>☛ 5.1.14 ID Sensor Error Analysis</p>						
301*	Transfer Current	<table border="1"> <tr> <td data-bbox="306 1424 363 1615">1</td> <td data-bbox="363 1424 667 1615">Normal paper</td> <td data-bbox="667 1424 1386 1615"> <p>Adjusts the current applied to the transfer roller when feeding from a paper tray. [-2 = -4 μA / -1 = -2 μA / 0 = 0 μA / 1 = 2 μA / 2 = +4 μA] <i>Use a high setting if the user normally feeds relatively thick paper (within spec) from a paper tray.</i> ☛ 6.12.2 Image Transfer Current Timing</p> </td> </tr> <tr> <td data-bbox="306 1615 363 1874">2</td> <td data-bbox="363 1615 667 1874">Thick/Special paper</td> <td data-bbox="667 1615 1386 1874"> <p>Adjusts the current applied to the transfer roller when feeding from the by-pass tray. [-2 = -4 μA / -1 = -2 μA / 0 = 0 μA / 1 = 2 μA / 2 = +4 μA] <i>Use a high setting (a) if the user normally feeds relatively thick paper from the by-pass tray, or (b) if waste toner is re-attracted from the drum (which can occur when using transparencies).</i> ☛ 6.12.2 Image Transfer Current Timing</p> </td> </tr> </table>	1	Normal paper	<p>Adjusts the current applied to the transfer roller when feeding from a paper tray. [-2 = -4 μA / -1 = -2 μA / 0 = 0 μA / 1 = 2 μA / 2 = +4 μA] <i>Use a high setting if the user normally feeds relatively thick paper (within spec) from a paper tray.</i> ☛ 6.12.2 Image Transfer Current Timing</p>	2	Thick/Special paper	<p>Adjusts the current applied to the transfer roller when feeding from the by-pass tray. [-2 = -4 μA / -1 = -2 μA / 0 = 0 μA / 1 = 2 μA / 2 = +4 μA] <i>Use a high setting (a) if the user normally feeds relatively thick paper from the by-pass tray, or (b) if waste toner is re-attracted from the drum (which can occur when using transparencies).</i> ☛ 6.12.2 Image Transfer Current Timing</p>
1	Normal paper	<p>Adjusts the current applied to the transfer roller when feeding from a paper tray. [-2 = -4 μA / -1 = -2 μA / 0 = 0 μA / 1 = 2 μA / 2 = +4 μA] <i>Use a high setting if the user normally feeds relatively thick paper (within spec) from a paper tray.</i> ☛ 6.12.2 Image Transfer Current Timing</p>						
2	Thick/Special paper	<p>Adjusts the current applied to the transfer roller when feeding from the by-pass tray. [-2 = -4 μA / -1 = -2 μA / 0 = 0 μA / 1 = 2 μA / 2 = +4 μA] <i>Use a high setting (a) if the user normally feeds relatively thick paper from the by-pass tray, or (b) if waste toner is re-attracted from the drum (which can occur when using transparencies).</i> ☛ 6.12.2 Image Transfer Current Timing</p>						

Service Tables

USING SERVICE PROGRAM MODES

2	Mode Number/Name		Function/[Setting]
301*	3	Duplex	<p>Adjusts the current applied to the transfer roller when carrying out a duplex job. $[-2 = -4 \mu\text{A} / -1 = -2 \mu\text{A} / 0 = 0 \mu\text{A} / 1 = 2 \mu\text{A} / 2 = +4 \mu\text{A}]$ <i>Use this SP if there is poor image transfer on the rear side of duplex copies.</i> ● 6.12.2 Image Transfer Current Timing</p>
	4	Cleaning	<p>Adjusts the current applied to the transfer roller for roller cleaning. $[-10 \sim 0 / -1 / 1 \mu\text{A}/\text{step}]$ <i>Increase the current if toner remains on the roller after cleaning. (Remaining toner may cause dirty background on the rear side.)</i> ● 6.12.2 Image Transfer Current Timing</p>
802	Forced Developer Churning		<p>Initializes the developer and checks the TD sensor output (Vt). The machine mixes the developer for 2 minutes while reading and displaying the Vt value. The machine does not initialize the TD sensor output. $[0 = \text{No} / 1 = \text{Yes}]$ <i>If the machine has not been used for a long period of time, prints may have a dirty background. In this case, use this SP mode to mix the developer. After finishing, press the  key to clear the Vt value from the screen.</i></p>
906*	Tailing Correction		<p>Shifts the image writing position in intervals specified by SP2-906-2. $[0.0 \sim 1.0 / 0.0 / 0.1 \text{ mm}/\text{step}]$ <i>When making many copies of an original that contains vertical lines (such as in tables), the paper may not separate correctly. This can cause tailing images (ghosts of the vertical lines continuing past the bottom of the table). This SP can be used to prevent this.</i></p>
	1	Shift value	
908	Forced Toner Supply		<p>Forces the toner bottle to supply toner to the toner supply unit. Press "1" to start. $[0 = \text{No} / 1 = \text{Yes}]$ <i>The machine continues to supply toner until the toner concentration in the development unit reaches the standard level, or for up to 2 minutes (whichever comes first).</i></p>
915*	Polygon Mirror Motor Idling Time		<p>Selects the polygon mirror motor idling time. $[0 = \text{None} / 1 = 15 \text{ s} / 2 = 25 \text{ s}]$ <i>To increase the speed of the first copy, the mirror motor begins idling when the user sets an original, touches a key, or opens the platen cover or DF. If this setting is left at the default (15 s), the motor will stop if the user does nothing for 15s. If the setting is "0", the motor will not switch off during standby. (But note that regardless of the setting, the motor will switch off when the machine enters energy saver mode.)</i></p>

USING SERVICE PROGRAM MODES

2	Mode Number/Name	Function/[Setting]
921*	Toner Supply Mode	<p>Selects the toner supply mode. [0 = Sensor 1 / 1 = Sensor 2 (DFU) / 2 = Fixed 1 (DFU) / 3 = Fixed 2] <i>Under normal conditions this should be set to "0". You can temporarily change this to "3" if the TD sensor is defective. Do not set to "1" or "2", as these are for design use only.</i> ⚡ 6.9.6 Toner Density Control</p>
922*	Toner Supply Time	<p>Adjusts the toner supply motor ON time for Sensor 1 and Sensor 2 toner supply mode. Accordingly, this setting is effective only if SP2-921 is set to "0" or "1" [0.1 ~ 5.0 / 0.4 / 0.1 s/step] <i>Raising this value increases the toner supply motor ON time. Set to a high value if the user tends to make many copies having high proportions of solid black image areas.</i> ⚡ 6.9.6 Toner Density Control</p>
923*	Toner Recovery Time	<p>Adjusts the toner supply motor ON time used during toner recovery from Toner Near End or Toner End. This setting is effective only if SP2-921 is set to "0" [3 ~ 60 / 30 / 1 s/step] <i>Since toner recovery is carried out in 3-second cycles, the input value should be a multiple of 3 (3, 6, 9...).</i> ⚡ 6.9.6 Toner Density Control</p>
925*	Toner Supply Rate	<p>Adjusts the toner supply time for fixed toner supply mode. This setting is effective only if SP2-921 is set to "2" or "3". [0 ~ 7 / 0] <i>t = 200ms, and settings are as follows</i> 0 = t 4 = 12t 1 = 2t 5 = 16t 2 = 4t 6 = on continuously 3 = 8t 7 = 0 s <i>Raising this value increases the toner supply motor ON time. Set to a high value if the user tends to make many copies having high proportions of solid black image areas.</i> ⚡ 6.9.6 Toner Density Control</p>
926*	Standard Vt	<p>Adjusts Vts (the Vt value for new developer). The TD sensor output is adjusted to this value during the TD sensor initial setting process]. [0.00 ~ 5.00 / 2.40 / 0.01 V/step] DFU <i>This SP is effective only when SP2-921 is "0", "1", or "2".</i></p>
927*	ID Sensor Control	<p>Selects whether the ID sensor is or is not used for toner density control. [0 = No / 1 = Yes] <i>This value should normally be left at "1". If the value is "0", dirty background may occur after long periods of non-use.</i></p>

Service Tables

2	Mode Number/Name	Function/[Setting]
928	Toner End Clear	<p>Clears the toner end condition without adding new toner. Select "1" then press the $\text{\textcircled{R}}$ key to clear the condition. [0 = No / 1 = Yes] <i>Setting this to "1" will clear the following:</i></p> <ul style="list-style-type: none"> • Toner end indicator (goes out) • Toner near-end counter • Toner near-end level <p><i>This function should generally not be used. If you clear the toner end condition without adding new toner, there is a risk that the drum may eventually begin to attract carrier after many more copies are made and toner runs out. This attracted carrier may damage the drum.</i></p>
929*	Vref Limits	
	1 Upper	Adjust the upper Vref limit. [0.50 ~ 3.50 / 3.20 / 0.01V/step] DFU
	2 Lower	Adjust the lower Vref limit. [0.00 ~ 3.50 / 1.10 / 0.01V/step] DFU
995*	ID Sensor Detection Interval	<p>If the machine starts warm-up after this amount of time has passed since entering night/off mode (for example, to print an incoming fax), the machine makes an ID sensor pattern. [0 ~ 240 / 90 / 1 minute/step] <i>Higher values increase the chance of dirty background. Lower values increase the frequency at which the machine makes ID sensor patterns, increasing the chance that the transfer roller (rear side of paper) will become dirty.</i></p>
996*	Transfer Roller Cleaning	<p>Selects whether the transfer roller is cleaned before each copy job. [0 = No / 1 = Yes] <i>Set this to "1" if dirty background is appearing on the reverse side of the first page of copy jobs. Note that this will increase the time required to generate the first copy. If the setting is "0", the transfer roller is never cleaned.</i>  6.12.3 Transfer Roller Cleaning</p>
998*	Main Scan Magnification	<p>Adjusts the magnification along the main scan direction, for all print modes (copy, fax, printing). [-0.5 ~ +0.5 / 0.0 / 0.1%/step] IAJ <ul style="list-style-type: none"> • Use the $\text{\textcircled{+/-}}$ key to select "+" or "-" before entering the value. • The specification is $100 \pm 1.0\%$. </p>



SP4-XXX (Scanner)

4	Mode Number/Name	Function/[Setting]								
008*	Main Scan Magnification (Scanner)	Adjusts the magnification along the main scan direction, for scanning. [-1.0 ~ +1.0 / 0.0 / 0.1%/step] IAJ • Use the \odot key to select “+” or “-” before entering the value • The specification is $100 \pm 1.0\%$ • Main scan magnification is implemented in steps of 0.5. Accordingly, your input value should be a multiple of 0.5 (-1.0, -0.5, 0, +0.5, or +1.0)								
010*	Leading Edge Registration (Scanner)	Adjusts the leading edge registration for scanning in platen mode. [-5.0 ~ +5.0 / 0.0 / 0.1 mm/step] IAJ • (-): The image moves toward the leading edge. • (+): The image moves toward the trailing edge • Use the \odot key to select “+” or “-” before entering the value The specification is 2 ± 1.5 mm.								
011*	Side-to-side Registration (Scanner)	Adjusts the side-to-side registration for scanning in platen mode. [-10.0 ~ +6.0 / 0.0 / 0.1 mm/step] IAJ • Increasing the value shifts the image to the right • Use the \odot key to select “+” or “-” before entering the value • The specification is 2 ± 1.5 mm.								
012*	Erase Margin	<table border="1" data-bbox="304 1263 667 1451"> <tr> <td data-bbox="304 1263 363 1301">1</td> <td data-bbox="363 1263 667 1301">Leading edge</td> </tr> <tr> <td data-bbox="304 1301 363 1339">2</td> <td data-bbox="363 1301 667 1339">Trailing edge</td> </tr> <tr> <td data-bbox="304 1339 363 1377">3</td> <td data-bbox="363 1339 667 1377">Left</td> </tr> <tr> <td data-bbox="304 1377 363 1451">4</td> <td data-bbox="363 1377 667 1451">Right</td> </tr> </table> Adjusts the scanning margin individually for each of the four edges. [0 ~ 9.0 / 1.0 / 0.1 mm/step] IAJ It is generally best to adjust the scanning margin as little as possible, and use the printing margin for image adjustments.	1	Leading edge	2	Trailing edge	3	Left	4	Right
1	Leading edge									
2	Trailing edge									
3	Left									
4	Right									
013	Scanner Free Run	Performs a scanner free run with the exposure lamp on. [0 = No / 1 = Yes] After selecting “1”, press OK or $\text{F}\#$ twice to start the run. Press \odot to stop.								

Service Tables

USING SERVICE PROGRAM MODES

4	Mode Number/Name	Function/[Setting]
015*	White Plate Scanning	
	1	Start position Adjusts the scanning start position on the white plate for auto shading. [-3.0 ~ +6.0 / 0.0 / 0.1 mm/step] <i>The base value stored in the machine is 15.2 mm toward the white plate from the scanner H.P.. This SP setting specifies the offset from this base value.</i>
	2	Scanning length Adjusts the length of the white plate scan, in the main scan direction. The scan begins at the start position set above [in SP4-015-1] and extends for the specified length. [-3.0 ~ +6.0 / 0.0 / 0.1 mm/step] <i>The base value stored in the machine is 4.76 mm. This SP setting specifies the offset from this base value.</i>
101*	Sub-Scan Magnification (Scanning)	
		Adjusts the actual sub-scan direction scanning magnification. The higher the setting, the lower the scanner motor speed. [-0.9 ~ +0.9 / 0.0 / 0.1%/step]
301	APS Data Display	
		Displays the status of the APS sensors and platen/DF cover sensor. ☛ 5.1.11 APS and Platen/ADF Cover Sensor Output Display
303*	APS Small Size Original	
		Selects whether or not the copier will consider the original to be A5 LEF when the APS sensors cannot detect its size. [0 = No (not detected) / 1 = Yes (A5 LEF)] <i>If "Yes" is selected, paper sizes that cannot be detected by the APS sensors are regarded as A5 LEF. If "No" is selected, "Cannot detect original size" will be displayed.</i>
902*	Exposure Lamp ON	
		Turns on the exposure lamp. [0 = No (Off) / 1 = Yes (On)] <i>To turn off the exposure lamp, select "0". (The exposure lamp shuts off automatically after 30 seconds.)</i>
903	SBU Black Feedback Display	
	1	EVEN
	2	ODD
		Displays the black level feedback data in the SBU. DFU
904	SBU Black Level Adjustment	
	1*	EVEN target This is the reference value for the EVEN channel black level used for black level adjustment at power-up. [0 ~ 255 / 0 / 1/step] DFU <i>Use this mode to re-input the previous value after performing memory all clear (SP5-801).</i>
	2*	ODD target This is the reference value for the ODD channel black level used for black level adjustment at power-up. [0 ~ 255 / 0 / 1/step] DFU <i>Use this mode to re-input the previous value after performing memory all clear (SP5-801).</i>
	3	EVEN result Displays the value from the most recent EVEN channel black level adjustment. [0 ~ 255 / 0 / 1/step] DFU

4	Mode Number/Name		Function/[Setting]
904	4	ODD result	Displays the value from the most recent ODD channel black level adjustment. <u>[0 ~ 255 / 0 / 1/step]</u> DFU
	5	Number of attempts	Displays the number of times SBU black level adjustment was performed before the target values in 4-904-1 and 2 were reached. DFU
	6*	Factory setting - EVEN	Displays the value of the black level for the EVEN channel set at the factory. <u>[0 ~ 255 / 0 / 1/step]</u> DFU
	7*	Factory setting - ODD	Displays the value of the black level for the ODD channel set at the factory. <u>[0 ~ 255 / 0 / 1/step]</u> DFU
905	SBU White Level Adjustment		
	1*	EVEN target	This is the reference value for the EVEN channel white level used for white level adjustment at power-up. <u>[0 ~ 255 / 0 / 1/step]</u> DFU <i>Use this mode to re-input the previous value after performing memory all clear (SP5-801).</i>
	2*	ODD target	This is the reference value for the ODD channel white level used for white level adjustment at power-up (set at the factory). <u>[0 ~ 255 / 0 / 1/step]</u> DFU <i>Use this mode to re-input the previous value after performing memory all clear (SP5-801).</i>
	3	EVEN result	Displays the value from the most recent EVEN channel white level adjustment. <u>[0 ~ 255 / 0 / 1/step]</u> DFU
	4	ODD result	Displays the value from the most recent ODD channel white level adjustment. <u>[0 ~ 255 / 0 / 1/step]</u> DFU
	5	Number of attempts	Displays the number of times SBU white level adjustment was performed before the target values in 4-904-1 and 2 were reached. DFU
	6*	Factory setting - EVEN	Displays the value of the white level for the EVEN channel set at the factory. <u>[0 ~ 255 / 0 / 1/step]</u> DFU
	7*	Factory setting - ODD	Displays the value of the white level for the ODD channel set at the factory. <u>[0 ~ 255 / 0 / 1/step]</u> DFU
906	SBU White Level (EVEN/ODD)		
	1*	Set value	This is the reference value for the White Level EVEN/ODD adjustment carried out at power-up. <u>[0 ~ 600 / 0 / 1/step]</u> DFU <i>Use this mode to re-input the previous value after performing memory all clear (SP5-801).</i>
	2	Result	Displays the value from the most recent EVEN/ODD SBU White Level adjustment. DFU
3*	Factory setting	Displays the factory-set White Level EVEN/ODD setting. DFU	

Service Tables



USING SERVICE PROGRAM MODES

4	Mode Number/Name	Function/[Setting]
907	SBU Auto Adjustment Display 1* Set value 2 Result 3* Factory setting	This is the reference value for SBU Auto-Adjustment (white plate scanning). DFU <i>Use this mode to re-input the previous value after performing memory all clear (SP5-801).</i> Displays the value from the most recent SBU Auto-Adjustment. DFU Displays the factory-set SBU Auto adjustment value.
908	SBU Auto-Adjustment	Performs auto scanner adjustment. [0 = No (normal operation) / 1 = Yes (start adjustment)] <i>Use this SP mode after replacing the white plate.</i> ● IAJ 3.13.2 "Standard White Density Adjustment".
913*	DF Shading Interval	Adjusts the interval used for shading processing in DF mode. [0 ~ 60 / 20 / 1s/step] <i>Light and heat may affect the scanner response. Reduce this setting if copy quality indicates that the white level is drifting during DF copy jobs.</i>
921*	Image Adjustment Selection	Selects which mode the settings from SP4-922 to SP4-928 will be applied to. [0~10 / 0] 0 = None 5 = Photo 3 10 = Special 5 1 = Text 1 6 = Special 1 2 =Text 2 7 = Special 2 3= Photo 1 8 = Special 3 4 = Photo 2 9 = Special 4 ● 6.5.4 IPU
922*	Scanner Gamma Selection	Selects "text" or "photo" as the priority output mode [0 = Text / 1 = Photo] <i>This setting is applied to all image processing modes of SP4-921.</i> ● 6.5.4 IPU
923*	Notch Selection	Selects the value of the center ID adjustment notch for the ID adjustment LEDs. [-1 = Light / 0 = Normal / +1 = Dark] <ul style="list-style-type: none"> • Normally the center notch is 3 (range 1-5). If -1 is selected, each notch shifts down (becomes lighter). If +1 is selected, each notch shifts up (becomes darker). • This setting is applied to all image processing modes of SP4-921. ● 6.5.4 IPU

4	Mode Number/Name	Function/[Setting]									
925*	<p>Sharpness Adjustment</p> <table border="1"> <tr> <td data-bbox="308 309 360 539">1</td> <td data-bbox="360 309 665 539">Edge</td> <td data-bbox="671 309 1386 539"> <p>Adjusts the clarity of line images and of solid-image edges. Higher settings provide greater clarity. <u>[-2 ~ 2 / 0 / 1/step]</u> <ul style="list-style-type: none"> • <i>This setting is applied to all image processing modes of SP4-921.</i> • <i>It is used for both MTF filtering and smoothing.</i> ⚙ 6.5.4 IPU </p> </td> </tr> <tr> <td data-bbox="308 539 360 734">2</td> <td data-bbox="360 539 665 734">Solid image</td> <td data-bbox="671 539 1386 734"> <p>Adjusts the clarity of solid image areas. Higher settings provide greater clarity. <u>[-2 ~ 2 / 0 / 1/step]</u> <i>This setting is only applied to Text 2 and Special 1 of SP4-921.</i> ⚙ 6.5.4 IPU </p> </td> </tr> <tr> <td data-bbox="308 734 360 931">3</td> <td data-bbox="360 734 665 931">Low ID line</td> <td data-bbox="671 734 1386 931"> <p>Adjusts the clarity of lines with low image density. Higher settings provide greater clarity. <u>[-2 ~ 2 / 0 / 1/step]</u> <i>This setting is only applied to Text 1, Text 2, Photo 2, Special 1, Special 2, and Special 5 of SP4-921.</i> ⚙ 6.5.4 IPU </p> </td> </tr> </table>	1	Edge	<p>Adjusts the clarity of line images and of solid-image edges. Higher settings provide greater clarity. <u>[-2 ~ 2 / 0 / 1/step]</u> <ul style="list-style-type: none"> • <i>This setting is applied to all image processing modes of SP4-921.</i> • <i>It is used for both MTF filtering and smoothing.</i> ⚙ 6.5.4 IPU </p>	2	Solid image	<p>Adjusts the clarity of solid image areas. Higher settings provide greater clarity. <u>[-2 ~ 2 / 0 / 1/step]</u> <i>This setting is only applied to Text 2 and Special 1 of SP4-921.</i> ⚙ 6.5.4 IPU </p>	3	Low ID line	<p>Adjusts the clarity of lines with low image density. Higher settings provide greater clarity. <u>[-2 ~ 2 / 0 / 1/step]</u> <i>This setting is only applied to Text 1, Text 2, Photo 2, Special 1, Special 2, and Special 5 of SP4-921.</i> ⚙ 6.5.4 IPU </p>	
1	Edge	<p>Adjusts the clarity of line images and of solid-image edges. Higher settings provide greater clarity. <u>[-2 ~ 2 / 0 / 1/step]</u> <ul style="list-style-type: none"> • <i>This setting is applied to all image processing modes of SP4-921.</i> • <i>It is used for both MTF filtering and smoothing.</i> ⚙ 6.5.4 IPU </p>									
2	Solid image	<p>Adjusts the clarity of solid image areas. Higher settings provide greater clarity. <u>[-2 ~ 2 / 0 / 1/step]</u> <i>This setting is only applied to Text 2 and Special 1 of SP4-921.</i> ⚙ 6.5.4 IPU </p>									
3	Low ID line	<p>Adjusts the clarity of lines with low image density. Higher settings provide greater clarity. <u>[-2 ~ 2 / 0 / 1/step]</u> <i>This setting is only applied to Text 1, Text 2, Photo 2, Special 1, Special 2, and Special 5 of SP4-921.</i> ⚙ 6.5.4 IPU </p>									
926*	Texture Removal	<p>Adjusts the texture removal level. No adjustment is carried out if this is set to the default (0). Higher settings increase the amount of removal, which also tends to reduce the image clarity. <u>[0 ~ 5 / 0 / 1/step]</u> <i>This setting is only applied to Text 1, Photo 1–3, Special 2, and Special 5 of SP4-921.</i> ⚙ 6.5.4 IPU </p>									
927*	Line Width Correction	<p>Adjusts the line width correction algorithm. Positive settings produce thicker lines; negative settings produce thinner lines. <u>[-2 ~ 2 / 0 / 1/step]</u> <i>This setting is only applied to Text 1, Text 2, Photo 2, Special 1, Special 2, and Special 5 of SP4-921.</i> ⚙ 6.5.4 IPU </p>									
928*	Independent Dot Erase	<p>Selects the dot erase level. Higher settings provide greater erasure. <u>[-2 ~ 2 / 0 / 1/step]</u> <i>This setting is only applied to Text 1, Text 2, Photo 2, Special 1, Special 2, and Special 5 of SP4-921.</i> ⚙ 6.5.4 IPU </p>									







4	Mode Number/Name	Function/[Setting]					
941*	White Line Erase	Selects the white line erase level. <u>[0 ~ 5 / 2 / 1/step]</u> <i>None Weak Strong</i> <i>0 1 - 2 - 3 - 4 - 5</i> <ul style="list-style-type: none"> • <i>This setting is effective only Photo 1, Photo 3, Special 3 or Special 4 mode.</i> • <i>0: White line erase is not used, and white level correction is used instead</i> • <i>This setting is applied regardless of what mode has been selected in SP4-921.</i> ⚡ 6.5.4 IPU					
⇒ 942*	Black Line Erase	Selects the black line erase level. This setting is effective only when originals are scanned by the A(R)DF. <u>[0 = None / 1 = Weak / 2 = Normal / 3 = Strong]</u> <i>This setting is applied regardless of what mode has been selected in SP4-921.</i> ⚡ 6.5.4 IPU (Have Engine Firmware 1.14 or Newer)					
943*	Positive/Negative	<table border="1" style="width: 100%; border-collapse: collapse;"> <tr> <td style="width: 20px; text-align: center;">1</td> <td style="width: 100px;">Text</td> <td rowspan="2" style="vertical-align: top;">[0 = No / 1 = Yes] DFU</td> </tr> <tr> <td style="text-align: center;">2</td> <td>Photo</td> </tr> </table>	1	Text	[0 = No / 1 = Yes] DFU	2	Photo
1	Text	[0 = No / 1 = Yes] DFU					
2	Photo						

SP5-XXX (Mode)













5	Mode Number/Name	Function/[Setting]
001	All Indicators On	Blinks all indicators on the operation panel. <i>Press OK or  to cause all LEDs to begin blinking at a 3-second cycle. After checking that LEDs are all blinking, press  or Cancel to exit.</i>
104*	A3/DLT Double Count	Selects whether the machine counts twice for each sheet of A3/11"x 17". [0 = No / 1 = Yes] <i>If this is set to "Yes" is selected, the total (mechanical) counter and the current user counter will both increment by two for each A3/11" x 17" sheet.</i>
113*	Optional Key Counter	Enables/disables the optional key counter. [0: = None / 1 = Key Counter] <i>You must set this value to 1 after installing the optional key counter.</i>
116*	Key Counter Timing	Selects whether the key counter increments at time of paper feed-in or at time of paper exit. [0 = Feed In / 1 = Exit]
120*	Key Counter Removal Reset	Determines under which conditions the copy job settings are reset when the key counter is removed. With 0, the settings are cleared if the counter is removed at the end of a job or midway through a job. With 1, they are only cleared if the counter is removed at the end of a job. With 2, they are not cleared at all, under either condition. [0=Yes / 1=Standby only / 2=No] <i>With duplex copies, the job settings are always preserved, regardless of the setting of this SP mode.</i>
143*	DF 180° Image Rotation	Selects whether images copied in DF mode are turned upside down (rotated 180 degrees). [0 = No / 1 = Yes] <i>Select "Yes" when copying to letter-headed copy sheets feeding from a paper tray.</i>
401*	User Code Mode	Enables/disables the User Code feature for copy mode. [0 = No / 1 = Yes] <ul style="list-style-type: none"> • Changing this value causes the following User Tool setting to change accordingly: [3. Copier Features] → • [12. Key Operator Tools] → [1. User Code Access]. • If the customer forgets a user code, you can retrieve it as follows. <ol style="list-style-type: none"> 1) Change this SP value from 1 to 0. 2) Use [3. Copier Features] → [12. Key Operator Tools] → [3. Print Counter List] to print out the counter list. 3) The list will show all the user codes.

Service Tables

USING SERVICE PROGRAM MODES

5	Mode Number/Name	Function/[Setting]
501*	PM Alarm Mode	
	1 Interval	Sets the base PM interval. [1 ~ 255 / 60 / 1K copies/step] <i>The value stored in this SP is used when the value of SP5-501-2 is "1".</i>
	2 On/Off	Enables/disables the PM alarm for the total number of prints, copies, and faxes. [0 = No / 1 = Yes]
801	Memory All Clear	Resets all software counters and returns all modes and adjustments to their defaults settings (except for some settings, such as SP5-811, SP5-907, SP5-916, and SP7-003 – 5.1.8 Memory All Clear for a full list). [0 = No / 1 = Yes] <ul style="list-style-type: none"> • After selecting "1", press the Original Type key and the  key at the same time to execute the clear. If the clear is successful, the display shows "Action completed". If the clear fails, the display shows "Error!!!". • This SP mode should be used only after replacing the NVRAM or when the copier has malfunctioned due to damaged NVRAM.  5.1.8 Memory All Clear
802	Scanner/Printer Free Run	Starts a free run of both the scanner and the printer. [0 = No / 1 = Yes] <i>After selecting "1", press the OK key or  key twice to start the run. Press  to stop the free run.</i>
803	Input Check	Displays the signals being received from sensors and switches. Press  to exit the program.  5.1.3 Input Check
804	Output Check	Turns on electrical components individually for test purposes.  5.1.4 Output Check
807*	Display Language Group	Selects the display language group. [0 = Standard / 1 = Option 1 / 2 = Option 2] <i>The actual display language can be selected using User Tools: [6. Language]</i>
809*	mm/inch Selection	Selects whether the display shows values in mm or inches. [North Am.: 0 = inch / 1 = mm] [EU/Asia: 0 = mm / 1 = inch]

USING SERVICE PROGRAM MODES

5	Mode Number/Name	Function/[Setting]						
810	SC Code Reset	<p>Resets all level-A service call conditions, such as fusing errors. (To reset SC 547, switch the machine off/on.) [0 = No / 1 = Yes]</p> <ul style="list-style-type: none"> • After selecting "1", press the Original Type key and the  key (or OK key) at the same time to execute the reset. If the reset is successful, the display shows "Action completed." If the reset fails, the display shows "Error!!!". <p>☛ 4.1 Service Call Conditions</p>						
811*	Serial Number Input	<p>Used to input the machine serial number (normally done at the factory). This is the serial number printed on SMC reports.</p> <p>☛ 5.1.13 Serial Number Input</p>						
812*	Service Telephone Number	<table border="1" style="width: 100%; border-collapse: collapse;"> <tr> <td style="text-align: center; width: 5%;">1</td> <td style="width: 35%;">Telephone</td> <td> <p>Use this to input the telephone number of the service representative. (The number is displayed when a service call condition occurs.)</p> <ul style="list-style-type: none"> • To input a dash, press . • To delete the current telephone number, press . </td> </tr> <tr> <td style="text-align: center;">2</td> <td>Facsimile</td> <td> <p>Use this to input the fax number printed on user counter reports.</p> <ul style="list-style-type: none"> • To input a dash, press . • To delete the current fax number, press . </td> </tr> </table>	1	Telephone	<p>Use this to input the telephone number of the service representative. (The number is displayed when a service call condition occurs.)</p> <ul style="list-style-type: none"> • To input a dash, press . • To delete the current telephone number, press . 	2	Facsimile	<p>Use this to input the fax number printed on user counter reports.</p> <ul style="list-style-type: none"> • To input a dash, press . • To delete the current fax number, press .
1	Telephone	<p>Use this to input the telephone number of the service representative. (The number is displayed when a service call condition occurs.)</p> <ul style="list-style-type: none"> • To input a dash, press . • To delete the current telephone number, press . 						
2	Facsimile	<p>Use this to input the fax number printed on user counter reports.</p> <ul style="list-style-type: none"> • To input a dash, press . • To delete the current fax number, press . 						
824	NVRAM Data Upload	<p>Uploads SP and UP mode data (except for some items such as counters and the serial number) from the flash memory on the BiCU board to a flash memory card.</p> <p>[0 = No / 1 = Yes]</p> <p><i>This SP can be used when a flash memory card has been plugged into the machine's card slot.</i></p> <p>☛ 5.1.10 NVRAM Data Upload/Download</p>						
825	NVRAM Data Download	<p>Downloads SP mode data from a flash memory card to the flash memory on the BiCU board.</p> <p>[0 = No / 1 = Yes]</p> <p><i>This SP can be used when a flash memory card has been plugged into the machine's card slot.</i></p> <p>☛ 5.1.10 NVRAM Data Upload/Download</p>						
826	Program Upload	<p>Uploads the system program from the flash memory on the BiCU board to a flash memory card.</p> <p>[0 = No / 1 = Yes]</p> <p><i>This SP can be used when a flash memory card has been plugged into the machine's card slot.</i></p> <p>☛ 5.1.9 Program Upload/Download</p>						

Service Tables

USING SERVICE PROGRAM MODES

5	Mode Number/Name	Function/[Setting]																
827	Program Download	<p>Downloads the system program from a flash memory card to the flash memory on the BICU board.</p> <p>[0 = No / 1 = Yes]</p> <p><i>This SP can be used when a flash memory card has been plugged into the machine's card slot.</i></p> <p>☛ 5.1.9 Program Upload/Download</p>																
901	Printer Free Run	<p>Performs a printer free run.</p> <p>[0 = No / 1 = Yes]</p> <p><i>After selecting "1", press OK or $\text{F}\#$ twice to start the run. Press CC to stop.</i></p>																
902	Test Pattern Print	<p>Prints a test pattern</p> <p><i>Press CC to enter copy-mode display, then print out the pattern.</i></p> <p>☛ 5.1.2 Test Pattern Printing</p>																
906*	Exhaust-Fan Control Timer	<p>Inputs the fan control time.</p> <p>[30 ~ 120 / 30 / 1 s/step]</p> <p><i>The fan maintains normal speed for the specified time after occurrence of an SC or following entry into Warm-up mode, Low Power mode, or Night/Off mode.</i></p>																
907*	Plug & Play Setting	<p>Selects the brand name and production name for the Plug and Play function (for Windows 95 and up). These names are registered in the NVRAM. If the NVRAM becomes defective, these names should be re-registered.</p> <ul style="list-style-type: none"> • <i>Use the Right or Left cursor key to scroll through the list of brand names. To select a brand name, press the Original Type key and the OK (or $\text{F}\#$) key at the same time. The LCD displays an asterisk (*) next to the number of the currently selected brand name.</i> • <i>After displaying any of the brand names, you can view the corresponding production name by pressing the Darker key. (If the production name is longer than 43 characters, hold down both the Darker and Lighter keys together to view the rest of the name).</i> 																
908	<table border="1" style="width: 100%; border-collapse: collapse;"> <tr> <td colspan="2" data-bbox="316 1514 667 1547">Fax Download/Upload</td> </tr> <tr> <td data-bbox="316 1547 360 1648">1</td> <td data-bbox="360 1547 667 1648">Program download</td> </tr> <tr> <td data-bbox="316 1648 360 1749">2</td> <td data-bbox="360 1648 667 1749">SRAM data download</td> </tr> <tr> <td data-bbox="316 1749 360 2007">3</td> <td data-bbox="360 1749 667 2007">SRAM data upload</td> </tr> </table>	Fax Download/Upload		1	Program download	2	SRAM data download	3	SRAM data upload	<table border="1" style="width: 100%; border-collapse: collapse;"> <tr> <td colspan="2" data-bbox="667 1514 1383 1547">Fax Download/Upload</td> </tr> <tr> <td data-bbox="667 1547 711 1648"></td> <td data-bbox="711 1547 1383 1648"> <p>Download the fax system program from a flash memory card to the flash memory on the FCU board.</p> <p>☛ Fax Service Manual</p> </td> </tr> <tr> <td data-bbox="667 1648 711 1749"></td> <td data-bbox="711 1648 1383 1749"> <p>Download fax setting data from a flash memory card to the SRAM on the FCU board.</p> <p>☛ Fax Service Manual</p> </td> </tr> <tr> <td data-bbox="667 1749 711 2007"></td> <td data-bbox="711 1749 1383 2007"> <p>Download fax setting data from the SRAM on the FCU to a flash memory card.</p> <p>☛ Fax Service Manual</p> </td> </tr> </table>	Fax Download/Upload			<p>Download the fax system program from a flash memory card to the flash memory on the FCU board.</p> <p>☛ Fax Service Manual</p>		<p>Download fax setting data from a flash memory card to the SRAM on the FCU board.</p> <p>☛ Fax Service Manual</p>		<p>Download fax setting data from the SRAM on the FCU to a flash memory card.</p> <p>☛ Fax Service Manual</p>
Fax Download/Upload																		
1	Program download																	
2	SRAM data download																	
3	SRAM data upload																	
Fax Download/Upload																		
	<p>Download the fax system program from a flash memory card to the flash memory on the FCU board.</p> <p>☛ Fax Service Manual</p>																	
	<p>Download fax setting data from a flash memory card to the SRAM on the FCU board.</p> <p>☛ Fax Service Manual</p>																	
	<p>Download fax setting data from the SRAM on the FCU to a flash memory card.</p> <p>☛ Fax Service Manual</p>																	

5	Mode Number/Name	Function/[Setting]
909*	NV-RAM Auto Backup	<p>Selects whether or not to back up the data written to the NV-RAM at power off (see conditions below). [0 = Disabled / 1 = Enabled] <i>When enabled, this function creates a back up of the data if it has been 24 hours since the power was turned on or since the machine last wrote to the NV-RAM. The backup goes to a special back-up area inside the NVRAM.</i></p>
911*	APS A4/LT LEF Priority	<p>Specifies whether the machine selects 8 1/2" x 11" LEF paper for A4 LEF originals (or vice versa for metric-based machines). [0 = No / 1 = Yes] <i>On inch-based models: If this setting is "Yes," the machine automatically selects 8 1/2" x 11" LEF if the APS sensors detect an A4 LEF original. On metric (mm) based models: If this setting is "Yes," the machine automatically selects A4 LEF if the APS sensors detect an 8 1/2" x 11" LEF original. This SP is ineffective if the machine has been set up to detect Chinese paper sizes (SP5-955).</i></p>
913	UP Mode Data Reset	<p>Resets the user tool settings. [0 = No / 1 = Yes]</p> <ul style="list-style-type: none"> • Note that the user codes, key operator code, and key operator printer counter value are <u>not</u> reset. • After selecting "1", press the Original Type key and the OK key (or  key) at the same time to execute the reset. If the reset is successful, the display shows "Action completed." If the reset fails, the display shows "Error!!!"
914*	Printer Counter Display	<p>Selects whether the printer counter is displayed on the LCD ([1. Counter] in the user tools) and in the counter list printout. [0 = No / 1 = Yes] <i>To display the printer counter on the LCD, press the Right cursor key once. To display the total counter, press it again.</i></p>
916*	Language UK/TW Priority	<p>Selects the default display language. [0 = UK (Asia version) / 1 = TW (Taiwan version)]</p> <ul style="list-style-type: none"> • Asia and Taiwan versions only. • This setting is <u>not</u> reset by Memory All Clear (SP5-801).

Service Tables

USING SERVICE PROGRAM MODES

5	Mode Number/Name	Function/[Setting]
930	Fax Forwarding Mode	<p>Selects whether the machine will accept changeover to fax mode following occurrence of an SC error. [0 = No / 1 = Yes] <i>When an SC occurs while there are received fax messages in the SAF memory, change the value to "1". Then access facsimile mode. Then forward the incoming data to another fax machine using the fax mode bit switches.</i></p>
940*	Image Rotation	<p>Enables/disables image rotation. [0 = Enabled / 1 = Disabled] <i>This function is used for both rotate sort and rotate copy.</i></p>
941*	Duplex Blank Page	<p>Selects whether the blank page is made on the front side or back side when using duplex copy mode. [0 = Back Side / 1 = Front Side]</p>
944*	APS Mode Setting	<p>Enables/disables APS mode as the power-up default. [0: Disabled / 1 = Enabled]</p>
950*	By-pass LG Size Detection	<p>Selects whether the machine can detect LG paper in the by-pass tray. [0 = No / 1 = Yes] <i>If "No" is selected, the machine detects LT instead of LG.</i></p>
951*	Interleave Count Setting	<p>Selects the interleave count used when interleave mode has been selected from User Tools [2. System Settings] → [11. Print Priority]. [1 ~ 20 / 5 / 1 page/step] <i>This determines what happens if there are jobs of different types waiting. If the setting is 5 (for example), interleave mode will print 5 pages of one job, then 5 pages of the next job, and so on.</i></p>
952*	By-pass Paper Type Reset	<p>Selects the operational default paper type for the by-pass tray. The machine returns to the value set here at power up and whenever  is pressed. [0 = Thick / 1 = Plain / 2 = Selected] <i>If the setting is "2", the paper type selected in the User Tools will be used.</i></p>









USING SERVICE PROGRAM MODES

5	Mode Number/Name	Function/[Setting]
955*	8K/16K Detection	
	1 Platen cover	<p>Selects whether the machine will detect 8K/16K instead of B4/B5 in platen cover mode. [0 = No / 1 = Yes]</p> <ul style="list-style-type: none"> • For China models only • To allow the machine to detect 8K/16K, first set this mode to “Yes”, then change the APS sensor positions as explained in Replacement & Adjustment – Changing the Original Sensor Position”. • Note that SP5-911 (APS A4/LT LEF Priority) is not effective if this setting is “Yes”. • If this setting is “No” (the default), the machine detects B4/B5 and not 8K/16K. <p>☛ 3.4.6 Changing the Original Sensor Position</p>
	2 ADF/ARDF	<p>Selects whether or not the machine will detect 8K/16K instead of A3/A4/B4/B5 in ADF/ARDF mode. [0 = No / 1 = Yes]</p> <ul style="list-style-type: none"> • For China models only • In this case, selecting “Yes” is sufficient to allow the machine to detect 8K/16K • Note that SP5-911 (APS A4/LT LEF Priority) is not effective if this setting is “Yes”. • If this setting is “No” (the default), the machine detects A3/A4/B4/B5 and not 8K/16K. <p>☛ 3.4.6 Changing the Original Sensor Position</p>
992	SMC Printing	<p>Selects the machine status list to be printed. See the “SMC Printing” section for details about how to print the list. [1 = SP / 2 = UP / 3 = Log / 4 = All / 5 = Big Font]</p> <ul style="list-style-type: none"> • Selection “5” is for printing reports to be sent by fax. • B039 machines (outside North America) require optional 16MB memory to support this feature <p>☛ 5.1.6 SMC Printing</p>

Service Tables

USING SERVICE PROGRAM MODES

SP6-XXX (Peripherals)

6	Mode Number/Name	Function/[Setting]
006*	ADF Registration	
1	Side-to-Side/Front	Adjusts the side-to-side registration for the front side of the original, for ADF mode. [-7.0 ~ +9.5 / 0.0 / 0.1 mm/step] IAJ Use the  key to select “+” or “-” before entering the value.
2	Leading edge	Adjusts the leading edge registration for ADF mode. [-5.0 ~ +5.0 / 0.0 / 0.1 mm/step] IAJ 0.1 mm/step Use the  key to select “+” or “-” before entering the value.
3	Trailing edge erase	Adjusts the trailing edge erase margin for ADF mode. [-3.0 ~ +3.0 / -1.0 / 0.1 mm/step] IAJ Use the  key to select “+” or “-” before entering the value.
4	Side-to-Side/Rear	Adjusts the side-to-side registration for the rear side of duplex originals, for ADF mode. [-7.0 ~ +9.5 / 0.0 / 0.5 mm/step] IAJ Use the  key to select “+” or “-” before entering the value.
007*	ADF Sub-scan Magnification	
		Adjusts the actual magnification ratio in the sub-scan direction, for ADF mode. [-0.9 ~ +0.9 / 0.0 / 0.1%/step] IAJ Use the  key to select “+” or “-” before entering the value.
009	ADF Free Run	
		Performs an ADF free run . [0 = No / 1 = Yes] After selecting “1”, press OK or  twice to start the run. Press  to stop.
010*	Stamp Position Adjustment	
		Adjusts the stamp position in the sub-scan direction, for fax mode. [-10 ~ +10 / 0 / 1mm/step]
901	ADF APS Data Display	
		Displays the status of the ADF original size sensors.  5.1.12 ADF APS Original Sensor Output Display
905*	ARDF Skew Correction	
		Enables/disables use of skew correction when the ARDF feeds the rear side of an original. [0 = No / 1 = Yes]
906*	ARDF Original Curl Adjustment	
		Adjusts the amount of original buckle at the ARDF registration roller when the ARDF feeds the rear side of an original. [-20 ~ +20 / 0 / 1 mm/step] This SP mode is effective only if SP6-905 is set to “1”.

USING SERVICE PROGRAM MODES

6	Mode Number/Name	Function/[Setting]
910	ADF/Printer Free Run	<p>Performs a free run for the ADF and printer using a special ROM.</p> <p>[0 = No / 1 = Yes] DFU</p>
911*	Binding Hole Range	<p>Selects the diameter of the binding holes in the original that the sensors will ignore. If set at "0", this function is disabled.</p> <p>[0 ~ 20 / 12 / 1 mm/step]</p> <p><i>Original jams may occur when feeding originals with binding holes, because these holes may be detected by the sensors. Use this SP to avoid this problem. For example, setting this value to 12 mm will cause the sensors to ignore binding holes up to 12 mm in diameter.</i></p>

USING SERVICE PROGRAM MODES

SP7-XXX (Data Log)





7	Mode Number/Name	Function/[Setting]	
001*	Total Operation Time		
		Displays the total operation time (total drum rotation time).	
002*	Counter – Original		
	1	Total	Displays the total number of scanned originals (total).
	2	Copier	Displays total number of scanned originals (copy mode only).
	3	Fax	Displays total number of scanned originals (fax mode only).
003*	Counter – Print		
	1	Total	Displays the total number of prints (total).
	2	Copier	Displays the total number of prints (copier mode).
	3	Fax	Displays the total number of prints (fax mode).
	4	Printer	Displays the total number of prints (printer mode).
	5	A3/DLT	Displays the total number of prints (A3/DLT).
101*	Counter – Paper Size		
	1	A3	Displays the total number of copies by paper size.
	2	B4	
	3	A4	
	4	B5	
	5	DLT	
	6	LG	
	7	LT	
	8	HLT	
	9	Others	
102*	Counter – By-pass Print		
	1	Special	Displays the total number of special paper prints fed from the by-pass tray.
	2	Thick	Displays the total number of thick paper prints fed from the by-pass tray.
201*	Counter - Total Scan (Non DF)		
		Displays the total number of scanned originals (not from the DF).	
204*	Counter - Printouts by Paper Tray		
	1	1st	Displays the total number of sheets fed from each paper feed station.
	2	2nd	
	3	3rd	
	4	4th	
	5	By-pass	
	6	Duplex	
205*	Counter – ADF		
		Displays the total number of originals fed by the ADF.	
211*	Display – APS Working Time (Cumm.)		
		Displays the accumulated APS working time.	
212*	Display – ID Sensor Working Time (Cumm.)		
		Displays the accumulated ID sensor working time.	

USING SERVICE PROGRAM MODES





7	Mode Number/Name	Function/[Setting]
301*	Counter – Magnification	
	1	50% ~ 99%
	2	Full size
	3	101% ~ 200%
	4	Auto reduce/enlarge
	5	Fixed magnification
304*	Counter – Mode	
	1	Text
	2	Photo
	3	Duplex - Printing
	4	Duplex - Original
	5	Combined
	6	Series
	7	Sort
	8	ADF
305*	Counter – Copy Q'ty	
	1	1 to 1
	2	1 to 2 ~ 5
	3	1 to 6 ~ 10
	4	1 to 11 ~ 20
	5	1 to 21 ~ 99
401*	Counter – SC Total	
		Displays the total number of logged SC codes.
402*	Counter – by each SC	
		Displays the total number of each type of logged SC code. [0 = No / 1 = Yes]
501*	Counter – Total Jams	
		Displays the total number of jams (copy paper + original).
502*	Counter – Total Paper Jams	
		Displays the total number of copy paper jams.
503*	Counter – Total Original Jams	
		Displays the total number of original jams,
504*	Total Jams by Location	
	1	"A" jams
	2	"B" jams
	3	"Y" jams
	4	"Z" jams
	5	1st
	6	2nd
	7	3rd
	8	4th
	9	By-pass
	10	Duplex unit
		Displays the total number of copy paper jams by location.

Service
Tables

USING SERVICE PROGRAM MODES

7	Mode Number/Name	Function/[Setting]
801	Memory/Version/PN 1 Main P/N 2 Main version 3 Fax P/N 4 Printer P/N 5 ADF ROM 6 Copier memory 7 # optional trays	Displays the P/N and suffix of the copier firmware. Displays the version of the BiCU board Displays the P/N and suffix of the fax firmware. Displays the P/N and suffix of printer firmware. Displays the P/N and suffix of the ADF ROM. Displays the total amount of copier memory installed. Displays the number of optional paper trays currently installed.
803*	Display – PM Counter	Displays the PM counter value (since the last PM).
804	Reset – PM Counter	Resets the PM counter. [0 = No / 1 = Yes] <i>After selecting “1”, press the Original Type key and the OK key (or  key) at the same time to execute the reset. If the reset is successful, the display shows “Action completed.” If the reset fails, the display shows “Error!!!”.</i>
807	Reset – SC/Jam Counters	Resets the SC, paper, original, and total jam counter values. [0 = No / 1 = Yes] <i>After selecting “1”, press the Original Type key and the OK key (or  key) at the same time to execute the reset. If the reset is successful, the display shows “Action completed.” If the reset fails, the display shows “Error!!!”.</i>
808	Reset – Counters	Resets all counters except for the total print counters (SP7-003) and timer counter (SP7-991). [0 = No / 1 = Yes] <i>After selecting “1”, press the Original Type key and the OK key (or  key) at the same time to execute the reset. If the reset is successful, the display shows “Action completed.” If the reset fails, the display shows “Error!!!”.</i>
810	Reset – Key Operator Code	Resets the key operator code. [0 = No / 1=Yes] <ul style="list-style-type: none"> • <i>After selecting “1”, press the Original Type key and the OK key (or  key) at the same time to execute the reset. If the reset is successful, the display shows “Action completed.” If the reset fails, the display shows “Error!!!”.</i> • <i>If the customer forgets the key operator code, clear it by using this SP mode and re-input the code using: [2. System Settings] → [13. Key Operator Tools] → [14. Program Key Operator Code].</i>

USING SERVICE PROGRAM MODES



7	Mode Number/Name	Function/[Setting]
825	Reset – Total Counter	<p>Resets the electrical total counter. [0 = No / 1 = Yes]</p> <ul style="list-style-type: none"> • Usually, this is performed at installation. This SP mode is effective <i>only once</i>, while the counter still has a negative value. This SP mode cannot be used once the counter takes a positive value. • After selecting “1”, press the Original Type key and the OK key (or  key) at the same time to execute the reset. If the reset is successful, the display shows “Action completed.” If the reset fails, the display shows “Error!!!”.
901*	Display – SC History	<p>Displays the last twenty SC codes that have occurred. [0 = No / 1 = Yes]</p>
902	Clear – SC History	<p>Clears the SC history. [0 = No / 1 = Yes] <i>After selecting “1”, press the Original Type key and the OK key (or  key) at the same time to execute the reset. If the reset is successful, the display shows “Action completed.” If the reset fails, the display shows “Error!!!”.</i></p>
903*	Display – Paper Jam History	<p>Displays the paper jam history. [0 = No / 1 = Yes]</p>
904	Clear - Copy Jam History	<p>Clears the copy jam history. [0 = No / 1 = Yes] <i>After selecting “1”, press the Original Type key and the OK key (or  key) at the same time to execute the reset. If the reset is successful, the display shows “Action completed.” If the reset fails, the display shows “Error!!!”.</i></p>
905*	Display - Original Jam History	<p>Displays the original jam history. [0 = No / 1 = Yes]</p>
906	Clear - Original Jam History	<p>Clears the original jam history. [0 = No / 1 = Yes] <i>After selecting “1”, press the Original Type key and the OK key (or  key) at the same time to execute the reset. If the reset is successful, the display shows “Action completed.” If the reset fails, the display shows “Error!!!”.</i></p>
907	Reset - Timer Counter	<p>Resets the timer counter (SP7-991). [0 = No / 1 = Yes] <i>After selecting “1”, press the Original Type key and the OK key (or  key) at the same time to execute the reset. If the reset is successful, the display shows “Action completed.” If the reset fails, the display shows “Error!!!”.</i></p>

Service Tables

USING SERVICE PROGRAM MODES

7	Mode Number/Name	Function/[Setting]
908*	Display – Developer Counter	<p>Display the total number of prints made since the last Developer Initialization (SP2-214). <i>Note that this counter does not double count, even for A3 and 11" x 17". Developments are counted up at paper exit.</i></p>
911*	Display - ID Sensor Error Counter	<p>Displays the total number of logged ID sensor errors. <i>For the error analysis procedure, see 5.1.14 ID Sensor Error Analysis.</i></p>
912	Reset - ID Sensor Error Counter	<p>Resets the ID sensor error counter. [0 = No / 1 = Yes] <i>After selecting "1", press the Original Type key and the OK key (or  key) at the same time to execute the reset. If the reset is successful, the display shows "Action completed." If the reset fails, the display shows "Error!!!".</i></p>
991*	Display - Timer Counter	<p>Displays the total ON time for the machine.</p>

5.1.2 TEST PATTERN PRINTING (SP5-902)

1. Input the class-3 number for the test pattern you need.
2. Press  to access the copy mode display.
3. Select the required copy features such as paper size, image density, and reproduction ratio.
4. Press  again to print the test pattern.
5. After checking the test pattern, press  key to exit from copy mode.
6. Exit SP mode.

No.	Test Pattern using VCU
0	No Print
1	Vertical Lines (single dot)
2	Horizontal Lines (single dot)
3	Vertical Lines (double dot)
4	Horizontal Lines (double dot)
5	Grid Pattern (single dot)
6	Grid Pattern (double dot)
7	Alternating Dot Pattern
8	Solid Black
9	Black Band
10	Trimming Area
11	Argyle Pattern
12	Grayscales (Horizontal)
13	Grayscales (Vertical)
14	Grayscales (Vertical/Horizontal)
15	Grayscales (Vertical/Horizontal Overlay)
16	Grayscales with white lines (Horizontal)
17	Grayscales with white lines (Vertical)
18	Grayscales with white lines (Vertical/Horizontal)

No.	Test Pattern using IPU
31	Vertical Lines (single dot)
32	Horizontal Lines (single dot)
33	Vertical Lines (double dot)
34	Horizontal Lines (double dot)
35	Alternating Dot Pattern
36	Grid Pattern (single dot)
37	Vertical Stripes
38	Grayscales (Horizontal)
39	Grayscales (Vertical)
40	ID Patch
41	Cross Pattern
42	Argyle Pattern
43	Trimming Area

No.	Test Pattern using SBU
51	Vertical Lines (double dot)
52	Grid Pattern (single dot)
53	16 Grayscales



5.1.3 INPUT CHECK (SP5-803)

Input Check Code: 0

1. Access SP mode 5-803.
2. Select the number that will access the switch or sensor you wish to check (see the table below).
3. Check the status of the sensor or switch.
4. If you wish to check the signal during a copy cycle, select the required copy modes, then press .
5. The LCD panel will display "00H" or "01H", as shown below.

In #01=00H

The following table shows the meaning of each of the displayed values.

Number	Description	Reading	
		00H	01H
0	Not used		
1	Front/right cover safety switch	Closed	Opened
2	Front/right cover safety switch - LD5V	Closed	Opened
3	Right cover switch	Closed	Opened
4	Right Lower cover switch	Closed	Opened
5	Tray Cover Switch (Optional paper tray unit)	Closed	Opened
6 – 15	Not used		
16	Upper relay sensor	Paper not detected.	Paper detected.
17	Lower relay sensor	Paper not detected.	Paper detected.
18	Vertical transport sensor (Optional paper tray unit)	Paper not detected.	Paper detected.
19	Registration sensor	Paper not detected.	Paper detected.
20	Exit sensor	Paper not detected.	Paper detected.
21	Duplex inverter Sensor	Paper not detected.	Paper detected.
22	Duplex entrance sensor	Paper not detected.	Paper detected.
23	Duplex exit sensor	Paper not detected.	Paper detected.
24, 25	Not used		
26	By-pass paper end sensor	Paper not detected.	Paper detected.
27	By-pass paper size sensor	See Table 3.	
28 – 30	Not used		
31	Upper paper end sensor	Paper not detected.	Paper detected.

USING SERVICE PROGRAM MODES

Number	Description	Reading	
		00H	01H
32	Lower paper end sensor	Paper not detected.	Paper detected.
33	Upper paper size switch	See Table 1.	
34	Lower paper size switch	See Table 1.	
35, 36	Not used		
37	Upper paper end sensor (Optional paper tray unit)	Paper not detected.	Paper detected.
38	Lower paper end sensor (Optional paper tray unit)	Paper not detected.	Paper detected.
39	Upper paper size switch (Optional paper tray unit)	See Table 2.	
40	Lower paper size switch (Optional paper tray unit)	See Table 2.	
41	Upper paper height sensor (Optional paper tray unit)	See Table 4.	
42	Lower paper height sensor (Optional paper tray unit)	See Table 4.	
43	Upper lift sensor (Optional paper tray unit)	Paper not at upper limit	Paper at upper limit
44 – 52	Not used		
53	PCU set signal (a shorted connection in the TD sensor cable)	Not set	Set
54	Not used		
55	Paper tray unit type (Optional paper tray unit)	See Table 5.	
56, 57	Not used		
58	BiCU installed	Not installed	Installed
59 – 61	Not used		
62	Duplex unit installed	Not installed	Installed
63–68	Not used		
69	Lower lift sensor (Optional paper tray unit)	Paper not at upper limit	Paper at upper limit
70	Not used		
71	Main motor lock	Off	On
72	Polygonal mirror motor lock	Off	On
73	Tray motor lock	Off	On
74, 75	Not used		
76	Total (mechanical) counter installed	Not installed	Installed
77	Not used		
78	Key counter installed (Optional key counter)	Not installed	Installed
79, 80	Not used		
81	Laser synchronization signal	Not detected	Detected
82 – 89	Not used		
90	DF position sensor (Optional ADF)	Closed	Opened
91	Feed cover open sensor (Optional ADF)	Closed	Opened

USING SERVICE PROGRAM MODES

Number	Description	Reading	
		00H	01H
92	Original set sensor (Optional ADF)	Paper not detected.	Paper detected.
93	Registration sensor (Optional ADF)	Paper not detected.	Paper detected.
94	Original trailing edge sensor (Optional ADF)	Paper not detected.	Paper detected.
95	Optional exit sensor (Optional ADF)	Paper not detected.	Paper detected.
96	Original reverse sensor (Optional ADF)	Paper not detected.	Paper detected.
97, 98	Not used		
99	Platen cover sensor	Closed	Opened

Table 1: Paper Size Switch (Main Frame)

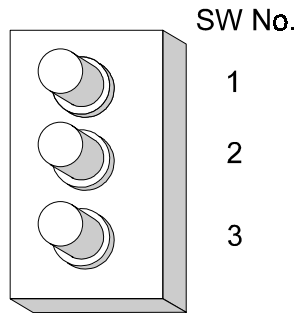

Number	SW 1	SW 2	SW 3	SP Value	Paper Size	
					inches	mm
33, 34	0	0	0	00H	—	
	0	0	1	04H	8 1/2" x 14"	A5 LEF
	0	1	0	02H	8 1/2" x 13"	
	0	1	1	06H	* (Asterisk)	
	1	0	0	01H	A4 LEF	
	1	0	1	05H	11" x 8 1/2"	
	1	1	0	03H	8 1/2" x 11"	A4 SEF
	1	1	1	07H	11" x 17"	A3

1: Pushed

Table 2: Paper Size Switch (Optional Paper Tray Unit)

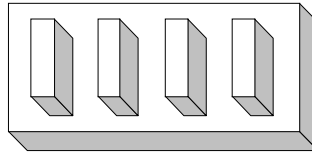

SW No. 1 2 3 4

Number	SW 1	SW 2	SW 3	SW 4	SP Value	Paper Size
39, 40	0	0	0	0	00H	—
	0	0	1	0	04H	A4 LEF
	0	0	1	1	0CH	A4 SEF
	0	1	0	1	0AH	11" x 17"
	0	1	1	1	0EH	11" x 8 1/2"
	1	0	0	0	01H	8 1/2" x 11"
	1	0	1	0	05H	* (Asterisk)
	1	1	0	0	03H	8 1/2" x 14"
	1	1	1	1	0FH	A3

1: Pushed

Table 3: By-pass Paper Size Sensor

Number	SP Value	Paper Size	
		mm	inches
27	06H	A3	11" x 17"
	02H	—	—
	03H	A4 SEF	8 1/2" x 11"
	01H	8" x 13"	—
	08H	A5 SEF	5 1/2" x 8 1/2"
	0CH	—	—
	04H	—	—

Table 4: Paper Height Sensors

Number	SP Value	Paper Amount
41, 42	00H	100%
	01H	70 ~ 75%
	02H	Near-end
	03H	25 ~ 30%

Table 5: Paper Tray Unit Set Sensor

Number	SP Value	Unit Installed
55	00H	None
	01H	Paper tray unit (2 trays)
	02H	Paper tray unit (1 tray)

Service Tables

5.1.4 OUTPUT CHECK (SP5-804)

Output Check
Code: 0 Data: 0

CAUTION: To prevent mechanical or electrical damage, do not keep an electrical component on for a long time.

1. Access SP mode 5-804.
2. Select the SP number that corresponds to the component you wish to check (see the table below), then press *OK* or $\text{R/}\#$.
3. Press “1”, then press *OK* or the $\text{R/}\#$ key to check that component.
4. To interrupt the test, press D, then press *OK* or $\text{R/}\#$.

Output Check Table

NOTE: Pull out the tray before performing output checks 28, 29, and 31.

Number	Description
0	Not used
1	Main motor (Forward)
2	Main motor (Reverse) Do not use
3	Quenching lamp
4 – 6	Not used
7	Toner supply motor (Forward)
8	Toner supply motor (Reverse) Do not use
9	Exhaust fan (High Speed)
10	Exhaust fan (Low Speed)
11	Registration clutch
12	By-pass feed clutch
13	Upper paper feed clutch
14	Lower paper feed clutch
15 – 18	Not used
19	Lower paper lift motor (Up) (Optional paper tray unit)
20	Lower paper lift motor (Down) (Optional paper tray unit)
21	Relay clutch
22	Not used
23	Relay clutch (Optional paper tray unit)
24, 25	Not used
26	Upper paper feed clutch (Optional paper tray unit)
27	Lower paper feed clutch (Optional paper tray unit)
28	Tray motor (Optional paper tray unit)

Number	Description
29	Upper paper lift motor (Up) (Optional paper tray unit)
30	Not used
31	Upper paper lift motor (Down) (Optional paper tray unit)
32 – 39	Not used
40	Duplex inverter motor (Reverse)
41	Duplex inverter motor (Forward)
42	Duplex transport motor (Forward)
43	Duplex inverter gate solenoid
44	Duplex inverter motor (Hold)
45	Duplex transport motor (Hold)
46 – 50	Not used
51	Polygonal mirror motor
52	Polygonal mirror motor and laser diode Do not use
53	Laser diode Do not use
54 – 89	Not used
90	DF transport motor (Optional ADF)
91	DF feed motor (Optional ADF)
92	DF feed clutch (Optional ADF)
93	DF pick-up solenoid (Optional ADF)
94	Stamp solenoid (Optional ADF)
95	DF junction gate solenoid (Optional ADF)
96 – 99	Not used

5.1.5 COPY JAM HISTORY (SP7-903)

After entering the SP mode, select "1" and press *OK* or $\text{R}\#$. The LCD panel displays the following message,

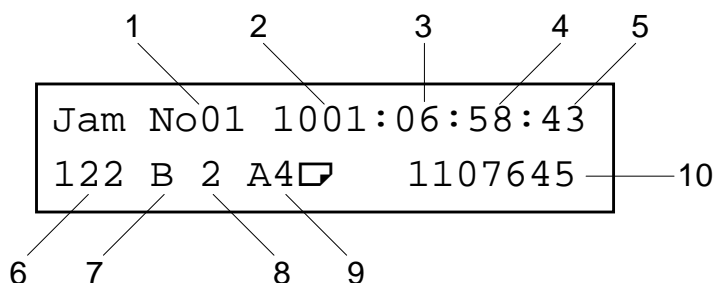

- | | |
|------------------------------------|---|
| 1. Jam history number | 7. Jam location |
| 2. Main motor operating time: Date | 8. Paper feed station |
| 3. Hour | 9. Paper size |
| 4. Minute | 10. Total counter value when the jam occurred |
| 5. Second | |
| 6. Jam code (see the table below) | |

Jam Code	Meaning
001	Jam at power on.
010	Paper did not reach the registration sensor (from a paper tray).
011	Paper did not reach the 1st relay sensor.
012	Paper caught at the 1st relay sensor.
021	Paper did not reach the 2nd relay sensor.
022	Paper caught at the 2nd relay sensor.
031	Paper did not reach the 3rd relay sensor.
032	Paper caught at the 3rd relay sensor.
050	Paper did not reach the registration sensor (from the by-pass tray).
070	Paper caught at the registration sensor.
120	Paper caught at the exit sensor (previous page).
121	Paper did not reach the exit sensor.
122	Paper caught at the exit sensor.
123	Paper did not reach the duplex inverter sensor (from the registration roller).
124	Paper did not reach the duplex inverter sensor (from the inverter tray).
125	Paper caught at the duplex inverter sensor.
126	Paper did not reach the duplex entrance sensor.
127	Paper caught at the duplex entrance sensor.
128	Paper did not reach the duplex exit sensor.
129	Paper caught at the duplex exit sensor.

NOTE: The NVRAM can store data for up to 10 copy jams. If more than 10 copy jams occur, the oldest data is erased.

Service Tables

5.1.6 SMC PRINTING (SP5-992)

NOTE: To use this feature on B039 models outside of North America, the optional 16MB must be installed.

1. Access SP mode 5-992 and select the number corresponding to the list that you wish to print.
2. Press \odot to access the copy mode display.
3. Select the paper size.
4. Press \odot again to print the list.
5. After printing the list, press \square to exit from copy mode.
6. Exit SP mode.

5.1.7 ORIGINAL JAM HISTORY DISPLAY (SP7-905)

After entering the SP mode, select "1" and press OK or \odot . The following message is displayed.

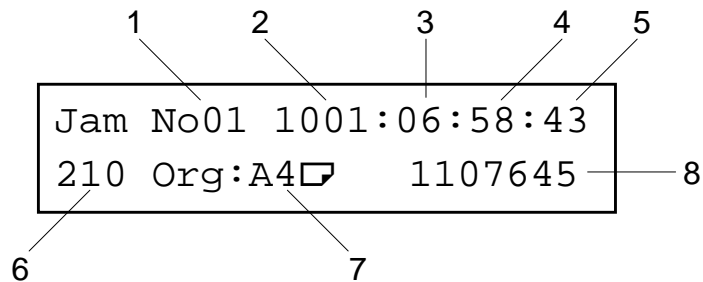

- | | |
|------------------------------------|---|
| 1. Jam history number | 6. Jam code (see the table below) |
| 2. Main motor operating time: Date | 7. Original size |
| 3. Hour | 8. Total counter value when the original jam occurred |
| 4. Minute | |
| 5. Second | |

Jam Code	Meaning
210	Original does not reach the registration sensor.
211	Original caught at the registration sensor.
212	Original does not reach the feed-out sensor.
213	Original caught at the feed-out sensor.
214	Original does not reach the inverter sensor.
215	Original caught at the inverter sensor.
216	Short interval between originals.
218	No original at the stamp.

NOTE: The NVRAM can store data for up to 10 original jams. If more than 10 original jams occur, the oldest data will be erased.

5.1.8 MEMORY ALL CLEAR (SP5-801)

NOTE: Memory All Clear mode resets all the settings and counters stored in the NVRAM to the defaults, except for the following:

- Electrical total counter values (SP7-003)
- Machine serial number (SP5-811)
- Plug & Play brand name and production name setting (SP5-907)
- Some SBU settings (SP4-904-6, SP4-904-7, SP4-905-6, SP4-905-7, SP4-906-3, SP4-907-3)
- Language UK/TW Priority (SP5-916) – Asia and Taiwan versions only

Normally, this procedure should not be used. It is necessary only after replacing the NVRAM, or when the copier malfunctions because the NVRAM is damaged.

Using a Flash Memory Card

1. Upload the NVRAM data to a flash memory card (☛ 5.1.10 NVRAM Data Upload).
2. Print out all SMC data lists (SP5-992).

NOTE: 1) For B039 models outside N. America, these lists cannot be printed without the IMB installed. Therefore, if it is not installed, write down all the data stored in NVRAM (all user tool settings, and all SP settings except for those listed above).

2) Be sure to print out all the lists. If the NVRAM data upload was not completed, it is necessary to change the SP mode settings by hand.
3. Access SP mode 5-801.
4. Press the *Original Type* key and the *OK* key (or ) key at the same time. If the operation is successful, the display shows “Action completed.” If the clear fails, the display shows “Error!!!”.
5. Turn the main switch off and back on.
6. Download the NVRAM data from a flash memory card (☛ 5.1.10 NVRAM Data Download).

Without Using a Flash Memory Card

If there is no flash memory card, follow the steps below.

1. Print out all SMC data lists (SP5-992).
NOTE: For B039 models outside N. America, these lists cannot be printed without the IMB installed. Therefore, if it is not installed, write down all the data stored in NVRAM (all user tool settings, and all SP settings except for those listed above).
2. Access SP mode 5-801.
3. Press the *Original Type* key and the *OK* key (or ) key at the same time. If the operation is successful, the display shows "Action completed". If the clear fails, the display shows "Error!!!".
4. Turn the main switch off and back on.
5. Do the printer and scanner registration and magnification adjustments (➡ Replacement and Adjustment – Copy Adjustments).
6. Refer to the SMC lists or the data you have written down, and re-enter any values that differ from the factory settings. In particular, the values for SP4-904, SP4-905, SP4-906, and SP4-907 must be re-entered.
7. Do the standard white level adjustment (SP4-908).
8. Check the copy quality and the paper path, and do any necessary adjustments.

5.1.9 PROGRAM UPLOAD/DOWNLOAD

The BiCU software for this machine is upgraded using a flash memory card.

There are two program download procedures.

- SP5-826: Upload from the BiCU to a flash memory card.
- SP5-827: Download from a flash memory card to the BiCU.

Program Download (SP5-827)

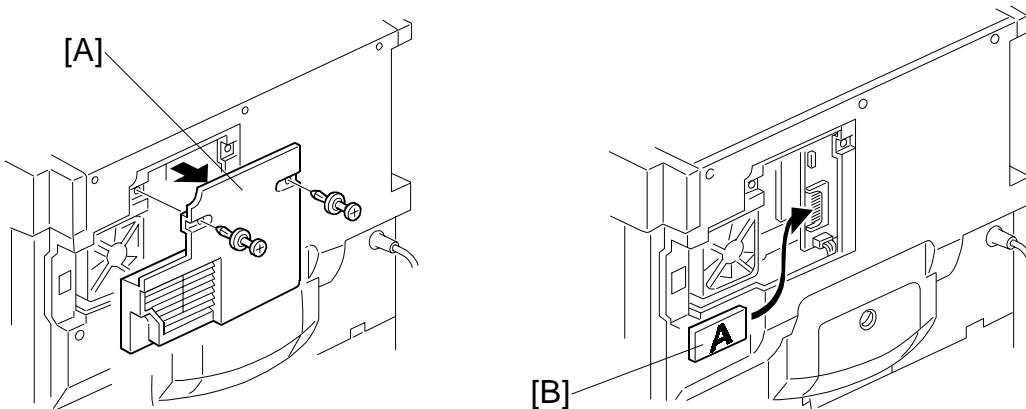

NOTE: Be sure to turn off the main switch before inserting or removing the flash memory. Installing or removing flash memory while the switch is still on may result in damage to the BiCU or to the memory.

1. Turn off the main switch.
2. Remove the rear middle cover [A] (2 rivets).
3. Insert the flash memory card [B] into the card slot.
NOTE: Make sure that the printed “A” on the card is facing the outside of the machine.
4. Hold down the *Operation Switch* and turn on the main switch.
5. To start the download, press the “1” key and then press *OK*.
6. The machine erases the current software, then writes the new software to the BiCU. This takes about 60 seconds. If downloading fails, an error message appears, as indicated below. If this occurs, repeat the download procedure.
7. After finishing the software download, turn off the main switch and remove the memory card.

USING SERVICE PROGRAM MODES

Display during writing.

```
Program Download
Load status:2-161402
```

Display when the download is complete.

```
Program Download
End sum=2A74 0.29EU
```

Display if writing has failed.

```
Program Download
Loading error!!!
```

NOTE: To view the current firmware version, check SP7-801-1.

Program Upload (SP5-826)

NOTE: Be sure to turn off the main switch before inserting or removing the flash memory. Installing or removing flash memory while the switch is still on may result in damage to the BiCU or to the memory.

1. Turn off the main switch.
2. Insert a flash memory card into the card slot (see the previous page).
NOTE: Make sure that the printed "A" on the card is facing the outside of the machine.
3. Turn on the main switch.
4. Access SP mode 5-826.
5. The machine erases the software on the card, then writes the new software to the flash memory card. This takes about 60 seconds. If uploading fails, an error message appears. If this occurs, repeat the upload procedure.
6. Turn off the main switch, then remove the memory card.

5.1.10 NVRAM DATA UPLOAD/DOWNLOAD

The “memory all clear” procedure will reset all NVRAM settings back to their defaults. It is therefore necessary to upload the NVRAM data before starting the clear, and then to download the data back after completing the clear.

- SP5-824: Upload from the BiCU to a flash memory card.
- SP5-825: Download from a flash memory card to the BiCU.

NVRAM Data Download (SP5-825)

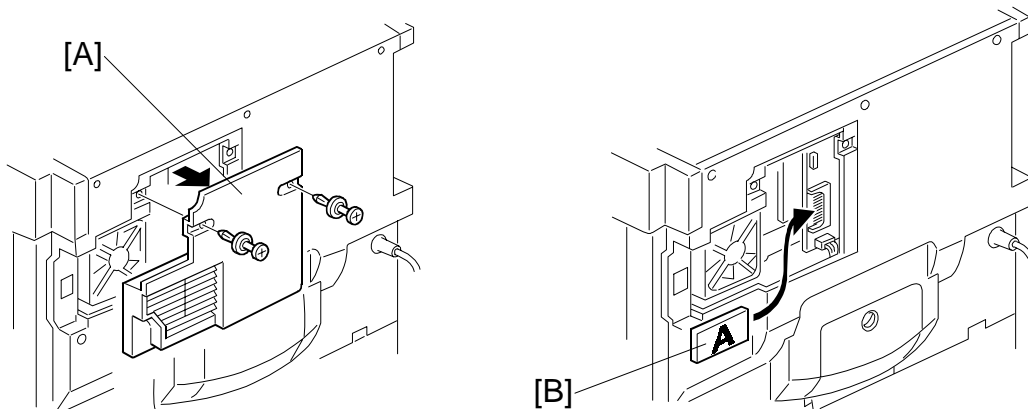

NOTE: This procedure downloads all the settings stored in the NVRAM, except the following values.

- Electrical total counter values (SP7-003)
- Machine serial number (SP5-811, SP5-920, SP5-925)
- Plug & Play brand name and production name setting (SP5-907)
- Some SBU settings (SP4-904-6, SP4-904-7, SP4-905-6, SP4-905-7, SP4-906-3, SP4-907-3)
- Language UK/TW Priority (SP5-916) – Asia and Taiwan versions only

NOTE: Be sure to turn off the main switch before inserting or removing the flash memory. Installing or removing flash memory while the switch is still on may result in damage to the BiCU or to the memory.

1. Turn off the main switch.
2. Remove the rear middle cover [A] (1 screw).
3. Insert the flash memory card [B] into the card slot.

NOTE: Make sure that the printed “A” on the card is facing the outside of the machine.

4. Turn on the main switch.
5. Access SP mode 5-825.

Service
Tables

USING SERVICE PROGRAM MODES

6. The machine erases the current settings, then writes the new settings onto the NVRAM on the BiCU board. This takes about 1 second. If downloading fails, an error message appears (see 5.1.9 “Program Download”). If the error message appears, repeat the download procedure.
7. Turn off the main switch, then remove the memory card.

NVRAM Data Upload (SP5-824)

1. Turn off the main switch.
2. Insert a flash memory card into the card slot. (See the previous page.)
NOTE: Make sure that the printed “A” on the card is facing the outside of the machine.
3. Turn on the main switch.
4. Access SP mode 5-824.
5. The machine erases the settings on the card, then writes the machine’s settings to the flash memory card. This takes about 20 seconds. If uploading fails, an error message appears (see 5.1.9 “Program Download”). If the error message appears, repeat the upload procedure.
6. Turn off the main switch, then remove the memory card.

5.1.11 APS AND PLATEN/ADF COVER SENSOR OUTPUT DISPLAY (SP4-301)

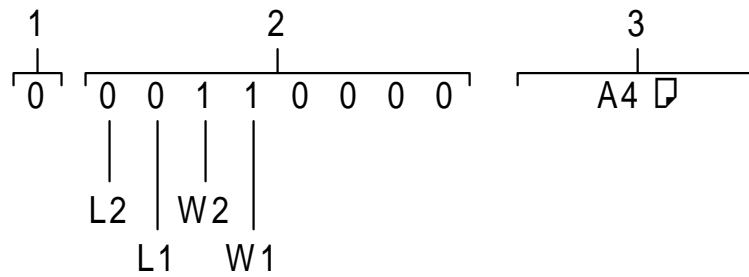
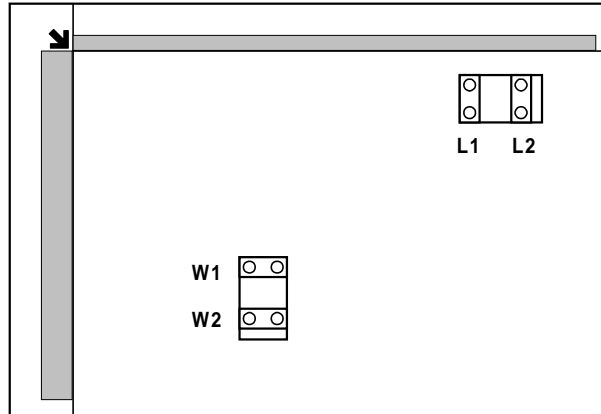

- | | |
|-------------------------------|--------------------|
| 1. Platen cover sensor status | 1 = Opened |
| 2. APS sensor status | 1 = Paper detected |
| 3. Paper size display | |

Service
Tables

USING SERVICE PROGRAM MODES

5.1.12 ADF APS SENSOR OUTPUT DISPLAY (SP6-901)

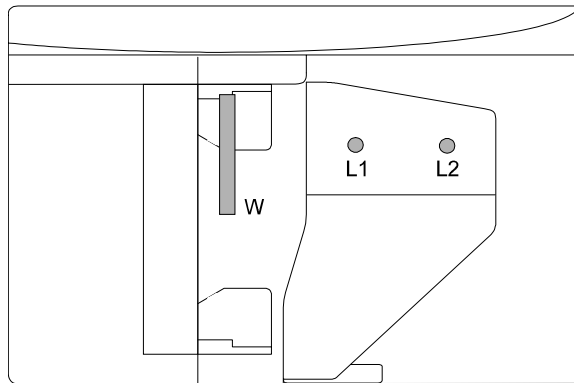

	Large ←		→ Small	
W1	0	0	1	1
W2	0	1	0	1

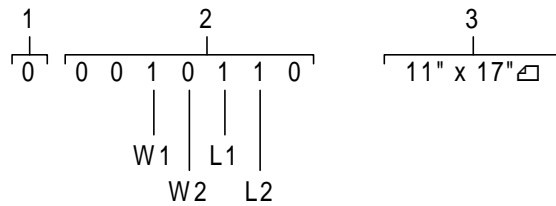

1. Original set sensor status 1 = Paper detected
2. APS sensor status 1 = Paper detected
3. Paper size display

W1	W2	L1	L2	Paper Size	
				NA	EU/AA
0	0	0	0	—	B5 LEF
0	0	1	1	10" x 14"	B4
0	1	0	0	8 1/2" x 5 1/2" LEF	A5 LEF
0	1	1	0	8 1/2" x 11" SEF	A4 SEF
1	1	1	1	8 1/2" x 14"	8 1/2" x 13"
1	0	0	0	11" x 8 1/2" LEF	A4 LEF
1	0	1	1	11" x 17"	A3
1	1	0	0	5 1/2" X 8 1/2" SEF	A5 SEF
1	1	1	0	—	B5 SEF

1: Detected

5.1.13 SERIAL NUMBER INPUT (SP5-811)

Used to input the machine's serial number (this is normally done at the factory). The numeric keypad has 12 buttons. Use the first 11 buttons ① to ⑨, ⑩/∞ and ⑪ to input the serial number (⑫ is not used). Each button represents one digit of the serial number. Press consecutively to get the required letter/number. The first 4 buttons allow you to scroll through numbers 0 to 9 and "A" to "Z". Buttons 5 to 11 only scroll through numbers 0 to 9.

①	②	③
1st digit	2nd digit	3rd digit
④	⑤	⑥
4th digit	5th digit	6th digit
⑦	⑧	⑨
7th digit	8th digit	9th digit
⑩/∞	⑪	⑫
10th digit	11th digit	Not used

5.1.14 ID SENSOR ERROR ANALYSIS (SP2-221)

VG: 3.84, VP: 0.27, PW: 139 VSDP: 3.57, VT: 2.09

A defective ID sensor does not generate an SC condition, but does cause the image quality to become worse (e.g., dirty background on the copy). If these conditions occur, check the ID sensor output using this SP mode.

1. Vsg (VG in the display)

Error Condition: $V_{sg} < 2.5V$ or $(V_{sg} - V_{sp}) < 1.00V$

Possible causes:

- ID sensor defective
- ID sensor dirty
- Drum does not get charged

2. Vsp (VP in the display)

Error Condition: $V_{sp} > 2.5V$ or $(V_{sg} - V_{sp}) < 1.00V$

Possible causes:

- Toner density is very low
- ID sensor pattern is not created

3. Power (PW in the display)

This is the power for the light source of the ID sensor.

Error Condition: $V_{sg} < 3.5V$ when maximum power (979) is applied

Possible causes:

- ID sensor defective
- ID sensor dirty
- Drum does not get charged

4. Vsdp

No Error Conditions

5. Vt

Error Condition: $V_t > 4.5V$ or $V_t < 0.2V$

Possible causes:

- TD sensor defective

5.2 USER TOOLS

The User Tools are accessed by users and key operators and by sales and service staff. User Tools are used to input or change the copier's default settings.

5.2.1 HOW TO ENTER AND EXIT USER TOOLS

Press the User Tools button, then select the User Tools program. After finishing the User Tools program, press the User Tools button to exit.

5.2.2 USER TOOLS TABLE

System Setting Table

2. System Settings	1. Function Priority		
	2. Copy Count Display		
	3. System Reset		
	4. Energy Saver Timer		
	5. Energy Saver Level		
	6. Auto Off Timer		
	7. AOF (Keep It On.)		
	8. Special Paper Size	1. Tray 1	
		2. Tray 2	
		3. Tray 3	
		4. Tray 4	
	9. Paper Tray Priority		
	10. Auto Tray Switch		
11. Print Priority			
12. Display Contrast			
13. Key Operators Tools	1. Show/Print Counter		
	2. Print Counter List		
	3. Key Operator Access		
	4. Program Key Operator Code		
	5. Restricted Access	1. Copier	
		2. Fax	
		3. Printer	

Service
Tables

USER TOOLS

Copy Features Table

3. Copier Features	1. APS Auto Reduce/Enlarge	
	2. Max. Copy Q'ty	
	3. Adjust Original Mode	1. Text 2. Photo
	4. Set Ratio	
	5. Copy Reset Timer	
	6. SADF Auto Reset	
	7. Rotate Sort Auto Continue	
	8. Orientation	
	9. Sort	
	10. Duplex Priority	
	11. Duplex Margin	
	12. Key Operator Tools	1. User Code Access 2. Check Copy Counter 3. Print Counter List 4. Reset Counter 5. Clear all User Codes 6. Reset All Counters 7. Program User Code 8. Change User Code 9. Delete User Code

DETAILED SECTION DESCRIPTIONS

6. DETAILED SECTION DESCRIPTIONS

6.1 OVERVIEW

6.1.1 COMPONENT LAYOUT

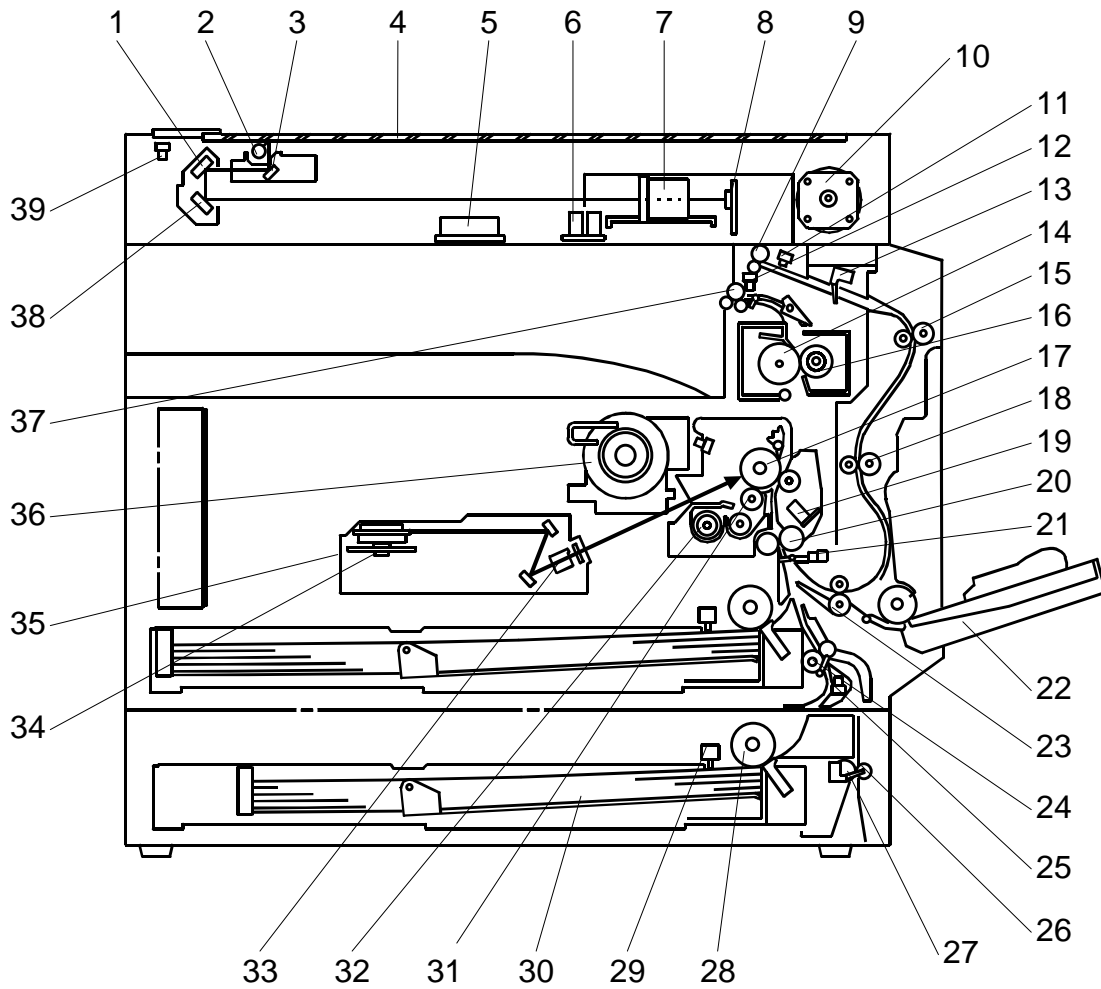

Detailed
Descriptions

NOTE: The above illustration is the B043 model.

B039: No duplex unit, one paper tray

B040: No duplex unit, two paper trays

OVERVIEW

1. 2nd Mirror
2. Exposure Lamp
3. 1st Mirror
4. Exposure Glass
5. Original Width Sensors
6. Original Length Sensors
7. Lens Block
8. SBU
9. Inverter Roller
10. Scanner Motor
11. Duplex Inverter Sensor
12. Exit Sensor
13. Duplex Entrance Sensor
14. Hot Roller
15. Upper Transport Roller
16. Pressure Roller
17. OPC Drum
18. Middle Transport Roller
19. Image Density Sensor
20. Registration Roller
21. Registration Sensor
22. By-pass Tray
23. Lower Transport Roller
24. Upper Relay Roller
25. Relay Sensor
26. Lower Relay Roller
27. Vertical Transport Sensor
28. Paper Feed Roller
29. Paper End Sensor
30. Bottom Plate
31. PCU
32. Development Roller
33. DTL -- Double Toroidal Lens
34. Polygon Mirror Motor
35. Laser Unit
36. Toner Supply Bottle Holder
37. Exit Roller
38. 3rd Mirror
39. Scanner H.P. Sensor

6.1.2 PAPER PATH

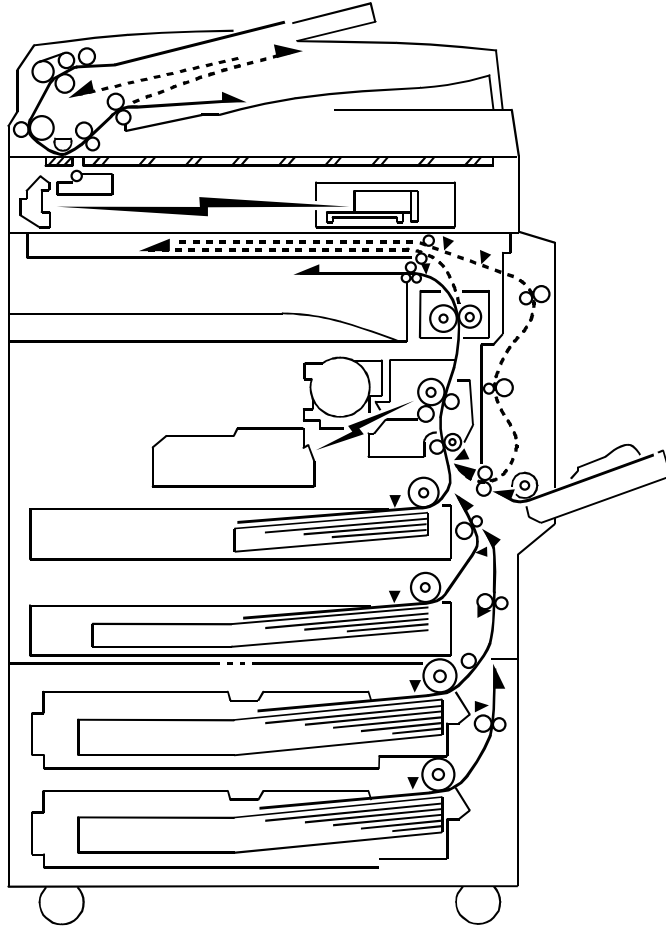

The B043 model has a duplex unit mounted on the right side of the machine.
All models have a by-pass tray.

OVERVIEW

6.1.3 DRIVE LAYOUT

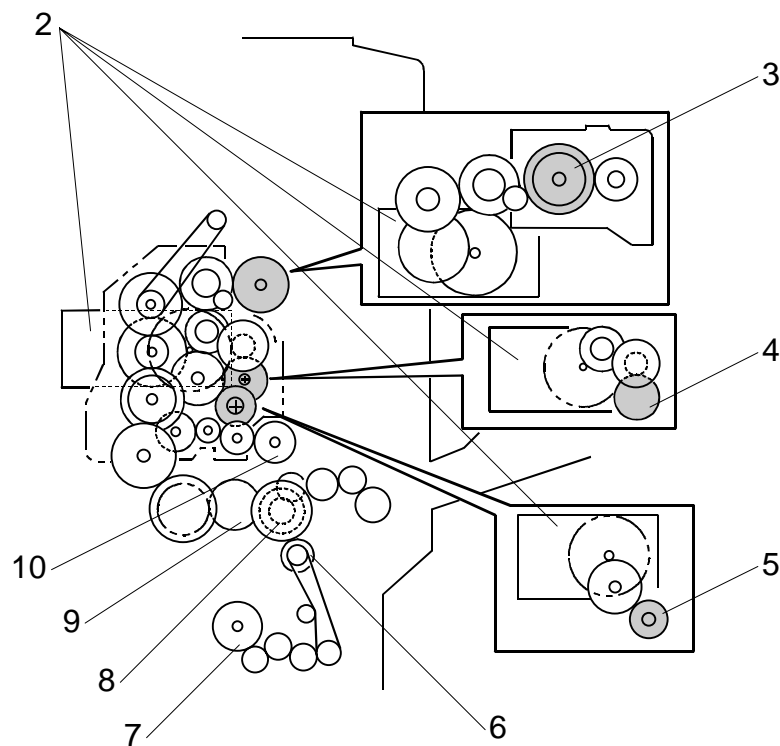
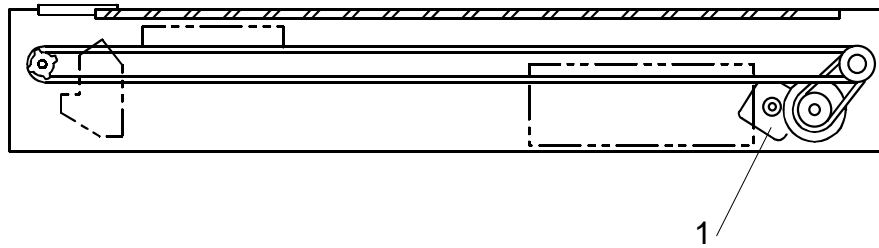

- | | |
|-----------------------|----------------------------|
| 1. Scanner Motor | 6. Relay Clutch |
| 2. Main Motor | 7. Lower Paper Feed Clutch |
| 3. Hot Roller | 8. By-pass Feed Clutch |
| 4. OPC Drum | 9. Upper Paper Feed Clutch |
| 5. Development Roller | 10. Registration Clutch |

6.2 BOARD STRUCTURE

6.2.1 BLOCK DIAGRAM

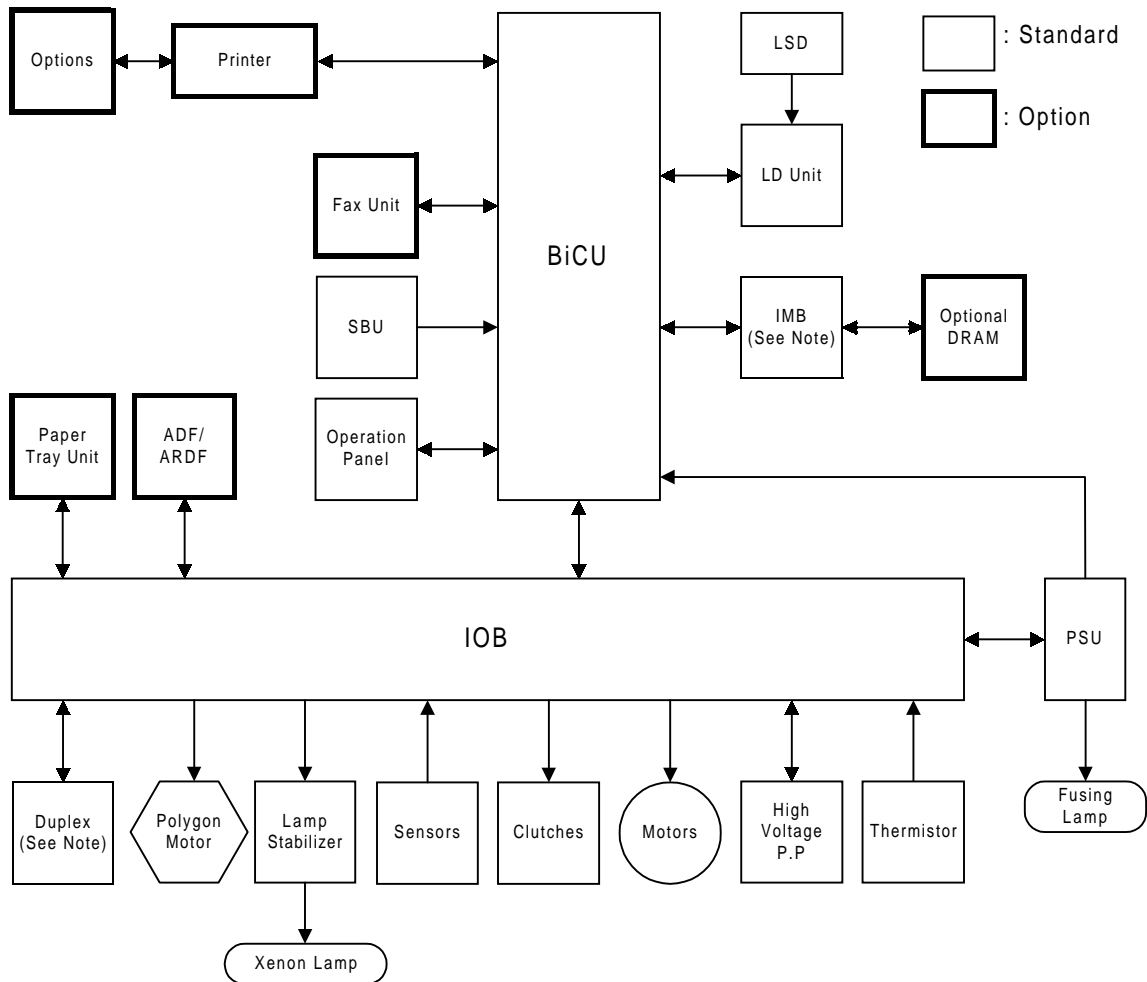

NOTE: 1) B039 models outside North America do not contain the IMB as a standard component.
 2) Only B043 models contain the duplex unit.

Detailed Descriptions

BOARD STRUCTURE

1. BiCU (Base Engine and Image Control Unit)

The main board controls the following functions:

- Engine sequence
- Timing control for peripherals
- Image processing, video control
- Operation control
- Various application boards (fax, printer)
- Machine control, system control

2. IOB (Input/Output Board)

The IOB handles the following functions:

- Drive control for the sensors, motors, and clutches of the printer and scanner
- High voltage supply board control
- Serial interfaces with peripherals
- Fusing control

3. SBU (Sensor Board Unit)

The SBU deals with the analog signals from the CCD and converts them into digital signals.

4. IMB (IMAC and Memory Board)

The IMB stores the image data. (➡ 6.5.5 IMB)

6.3 COPY PROCESS OVERVIEW

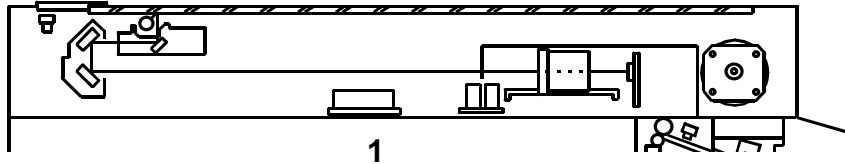

1. EXPOSURE

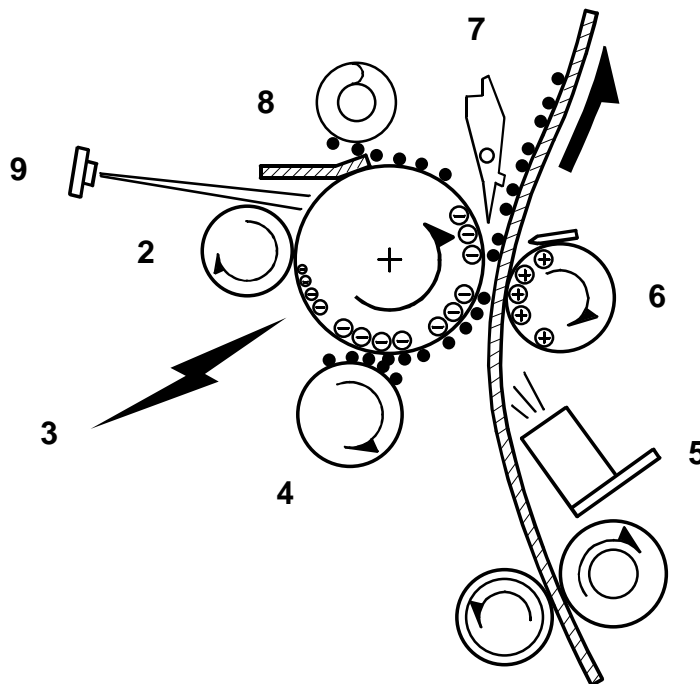

A xenon lamp exposes the original. Light reflected from the original passes to the CCD, where it is converted into an analog data signal. This data is converted to a digital signal, processed and stored in the memory. At the time of printing, the data is retrieved and sent to the laser diode.

NOTE: For multi-copy runs, the original is scanned once only and stored to the memory. B039 models outside N. America do not have memory as a standard component, so it must scan the original once for each copy.

2. DRUM CHARGE

In the dark, the charge roller gives a negative charge to the organic photoconductive (OPC) drum. The charge remains on the surface of the drum because the OPC layer has a high electrical resistance in the dark.

3. LASER EXPOSURE

The processed data scanned from the original is retrieved from the memory and transferred to the drum by a laser beam, which forms an electrical latent image on the drum surface. The amount of charge remaining as a latent image on the drum depends on the laser beam intensity, which is controlled by the BiCU board.

4. DEVELOPMENT

The magnetic developer brush on the development roller comes in contact with the latent image on the drum surface. Toner particles are electrostatically attached to the areas of the drum surface where the laser reduced the negative charge on the drum.

5. ID SENSOR

The laser forms a sensor pattern on the drum surface. The ID sensor measures the reflectivity of the pattern. The output signal is one of the factors used for toner supply control. Also, the ID sensor measures the reflectivity of the drum surface. The output signal is used for charge roller voltage control.

6. IMAGE TRANSFER

Paper is fed to the area between the drum surface and the transfer roller at the proper time for aligning the copy paper and the developed image on the drum surface. Then, the transfer roller applies a high positive charge to the reverse side of the paper. This positive charge pulls the toner particles from the drum surface onto the paper. At the same time, the paper is electrostatically attracted to the transfer roller.

7. PAPER SEPARATION

Paper separates from the drum as a result of the electrostatic attraction between the paper and the transfer roller. The discharge plate (grounded) helps separate the paper from the drum.

8. CLEANING

The cleaning blade removes any toner remaining on the drum surface after the image transfers to the paper.

9. QUENCHING

The light from the quenching lamp electrically neutralizes the charge on the drum surface.

6.4 SCANNING

6.4.1 OVERVIEW

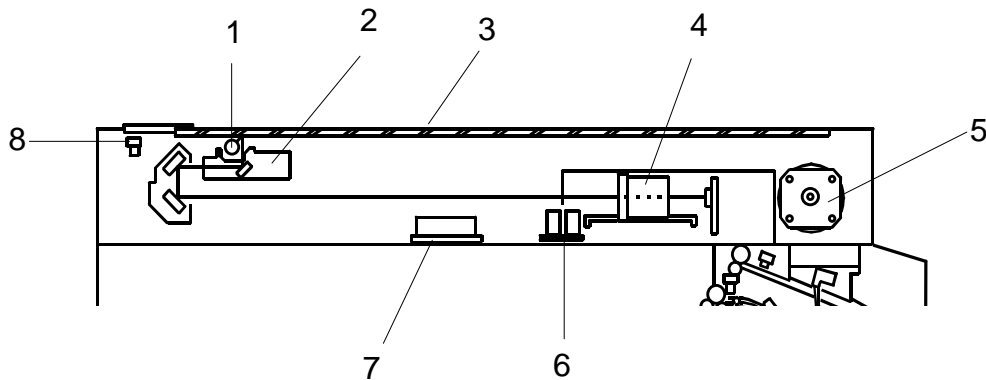

- | | |
|-------------------|---------------------------|
| 1. Exposure Lamp | 5. Scanner Motor |
| 2. 1st Scanner | 6. Original Length Sensor |
| 3. Exposure Glass | 7. Original Width Sensors |
| 4. Lens Block | 8. Scanner H.P. Sensor |

The original is illuminated by the exposure lamp (a xenon lamp). The image is reflected onto a CCD (charge coupled device) on the lens block via the 1st, 2nd, and 3rd mirrors, and through the lens on the lens block.

The 1st scanner consists of the exposure lamp, a reflector, and the 1st mirror.

A lamp stabilizer energizes the exposure lamp. The light reflected by the reflector is of almost equal intensity, to reduce shadows on pasted originals.

An optics anti-condensation heater is available as an option. It can be installed on the left side of the scanner. It turns on whenever the power cord is plugged in.

Lamp Stabilizer Fuse

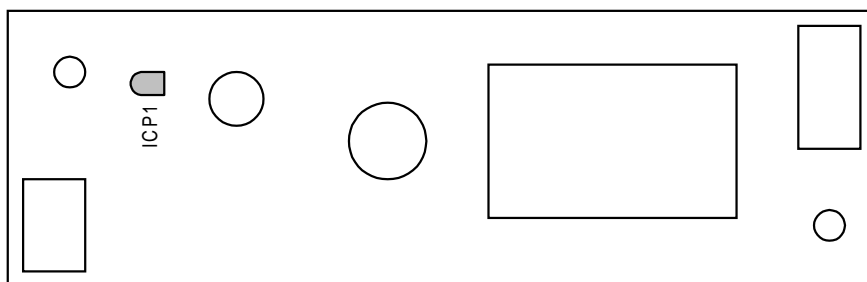

	Rating	Manufacturer	Type No.
ICP1	DC50 V/1.5 A	ROHM CO.,LTD	ICP-N38

Detailed Descriptions

6.4.2 SCANNER DRIVE

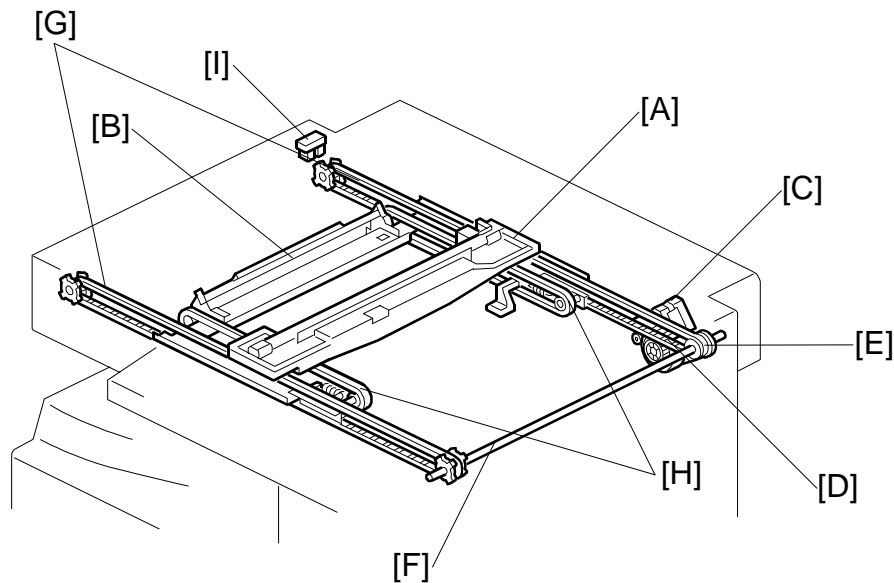

A stepper motor drives the 1st and 2nd scanners [A,B]. The 1st scanner is driven by the scanner drive motor [C], drive gear through the timing belt [D], scanner drive pulley [E], scanner drive shaft [F], and two timing belts [G]. The 2nd scanner is driven through the 1st scanner and two timing belts [H].

- Book mode -

The IOB controls and operates the scanner drive motor. In full size mode, the 1st scanner speed is 89 mm/s during scanning. The 2nd scanner speed is half that of the 1st scanner.

In reduction or enlargement mode, the scanning speed depends on the magnification ratio. The returning speed is always the same, whether in full size or magnification mode. The image length change in the sub scan direction is done by changing the scanner drive motor speed, and in the main scan direction it is done by image processing on the BiCU board.

Magnification in the sub-scan direction can be adjusted by changing the scanner drive motor speed using SP4-101. Magnification in the main scan direction can be adjusted using SP4-008.

- ADF mode -

The scanners are always kept at their home position (the scanner H.P. sensor [I] detects the 1st scanner) to scan the original. The ADF motor feeds the original through the ADF. In reduction/enlargement mode, the image length change in the sub-scan direction is done by changing the ADF motor speed. Magnification in the main scan direction is done in the BiCU board, like for book mode.

Magnification in the sub-scan direction can be adjusted by changing the ADF motor speed using SP6-007. In the main scan direction, it can be adjusted with SP4-008, like for book mode.

6.4.3 ORIGINAL SIZE DETECTION IN PLATEN MODE

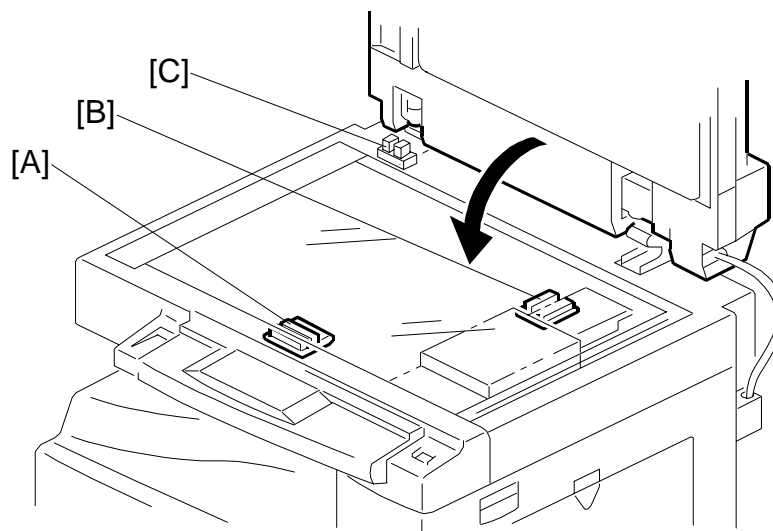

In the optics cavity for original size detection, there are four reflective sensors. The original width sensors [A] detect the original width, and the original length sensors [B] detect the original length. These are the APS (Auto Paper Select) sensors. Each APS sensor is a reflective photosensor.

While the main switch is on, these sensors are active and the original size data is always sent to the CPU. However, the CPU checks the data only when the platen cover sensor [C] is activated. This is when the platen is positioned about 15 cm above the exposure glass, for example while it is being closed. The CPU can recognize the original size from the combination of on/off signals from the APS sensors.

If the copy is made with the platen fully open, the CPU decides the original size from the sensor outputs when the Start key is pressed.

SCANNING

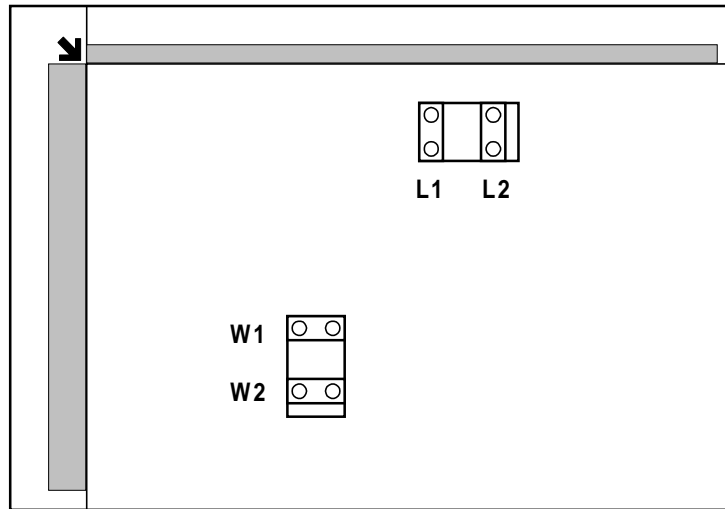

Original Size		Length Sensors		Width Sensors		SP4-301 display
A4/A3 version	LT/DLT version	L2	L1	W2	W1	
A3	11" x 17"	1	1	1	1	11110000
B4	8.5" x 14"	1	1	0	1	11010000
8.5" x 13"	—	1	1	0	0	11000000
A4-SEF	8" x 13"	0	1	0	0	01000000
A4-LEF	11" x 8.5"	0	0	1	1	00110000
B5-LEF	8.5" x 11"	0	0	0	1	00010000
A5-LEF	8.5" x 5.5"	0	0	0	0	00000000

NOTE: 0: No paper, 1: Paper present

The above table shows the outputs of the sensors for each original size. This original size detection method eliminates the necessity for a pre-scan and increases the machine's productivity.

For other combinations, "Cannot Detect Original Size" will be indicated on the operation panel display (if SP4-303 is kept at the default setting).

However, if the by-pass feeder is used, note that the machine assumes that the copy paper is short-edge first. For example, if A4 paper is placed long-edge first on the by-pass tray, the machine assumes it is A3 paper and scans the full A3 area for the first copy of each page of the original, disregarding the original size sensors. However, for each page, the data signal to the laser diode is stopped to match the copy paper length detected by the registration sensor. This means that copy time for the first page may be slower (because of the longer time required for scanning), but it will be normal for the rest of the job.

Original size detection using the ADF is described in the manual for the ADF.

6.5 IMAGE PROCESSING

6.5.1 OVERVIEW

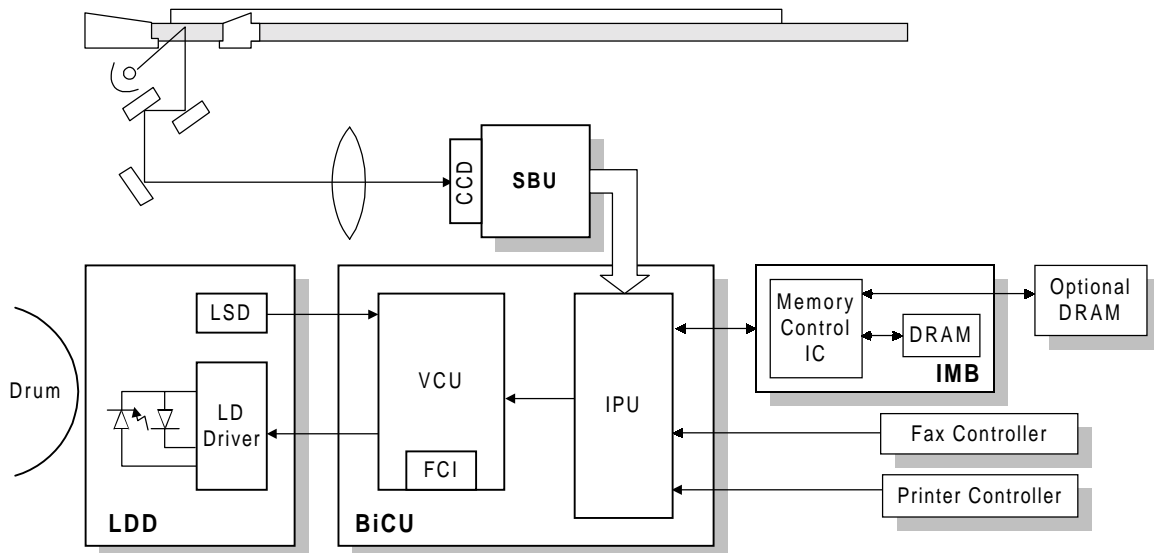

The CCD generates an analog video signal. The SBU (Sensor Board Unit) converts the analog signal to a 6-bit digital signal, then it sends the digital signal to the BiCU board.

The BiCU board can be divided into three image processing blocks: the IPU (Image Processing Unit), FCI (Fine Character Image), and VCU (Video Control Unit).

- IPU: Auto shading, filtering, magnification, scanner γ correction, ID γ correction
- VCU: Printer γ correction, LD print timing control and laser power PWM control
- FCI (inside the VCU): Smoothing

NOTE: The IPU and VCU are contained in the same IC on the BiCU

Finally, the BiCU board sends the video data to the LD drive board at the proper time. The IMB provides memory for the copier features (the B039 model outside N. America does not have the IMB as standard equipment). In addition, optional DRAM can be added to the IMB (☛ 6.5.5).

6.5.2 SBU (SENSOR BOARD UNIT)

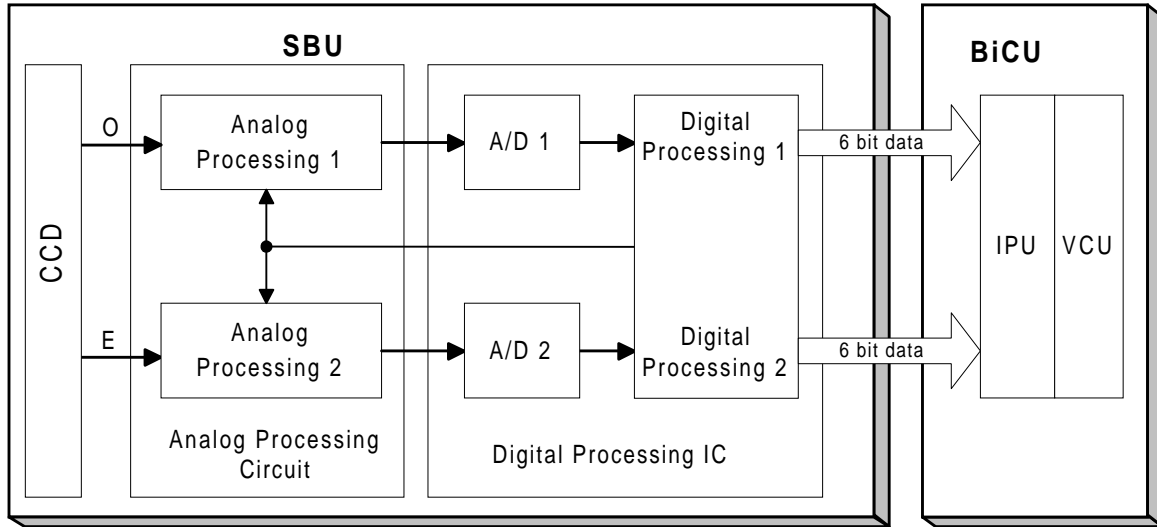

The CCD converts the light reflected from the original into an analog signal. The CCD line has 7,450 pixels and the resolution is 600 dpi (23.6 lines/mm).

The CCD has two output lines, for odd and even pixels, to the analog processing circuit. The analog processing circuit performs the following operations on the signals from the CCD:

1. Z/C (Zero Clamp):
Adjusts the black level reference for even pixels to match the odd pixels.
2. Signal Amplification:
The analog signal is amplified by operational amplifiers.

After the above processing, the analog signals are converted to 6-bit signals by the A/D converter. Each pixel will be assigned a value on a scale of 64 grades. Then, the digitized image data goes to the BiCU board.

6.5.3 AUTO IMAGE DENSITY (ADS)

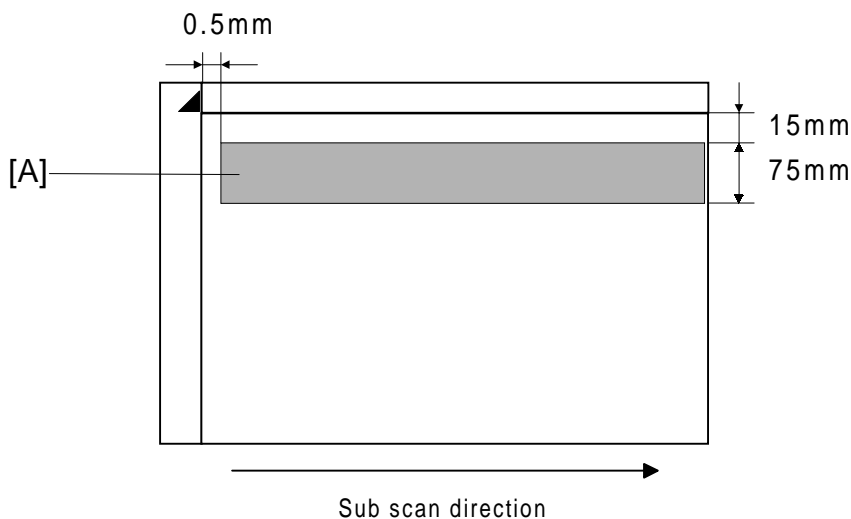

In the SBU

ADS prevents the background of an original from appearing on copies.

The copier scans the auto image density detection area [A] as shown in the diagram. This corresponds to a few mm at one end of the main scan line. As the scanner scans down the page, the IPU on the BiCU detects the peak white level for each scan line. The IPU determines the reference value for the A/D conversion for a particular scan line using the peak white level for that scan line. Then, the IPU sends the reference value data to the reference controller on the SBU.

When an original with a gray background is scanned, the density of the gray area is the peak white level density. Therefore, the original background will not appear on copies. Because peak level data is taken for each scan line, ADS corrects for any changes in background density down the page.

As with previous digital copiers, the user can select manual image density when selecting ADS, and the machine will use both settings when processing the original.

In the IPU

After the SBU process, the IPU board removes background noise resulting from the SBU-BiCU wiring by adjusting the white level.

By Original Type

ADS mode is only enabled when the user has selected:

- Text mode 1 or 2 (Normal or Sharp), Photo mode 2 (Text/Priority), or Special mode 1 or 2 (Unneeded background or Colored Text).

This can be done using *Adjust Original Mode (3)* in User Tools (Copier Features).

6.5.4 IPU (IMAGE PROCESSING UNIT)

Overview

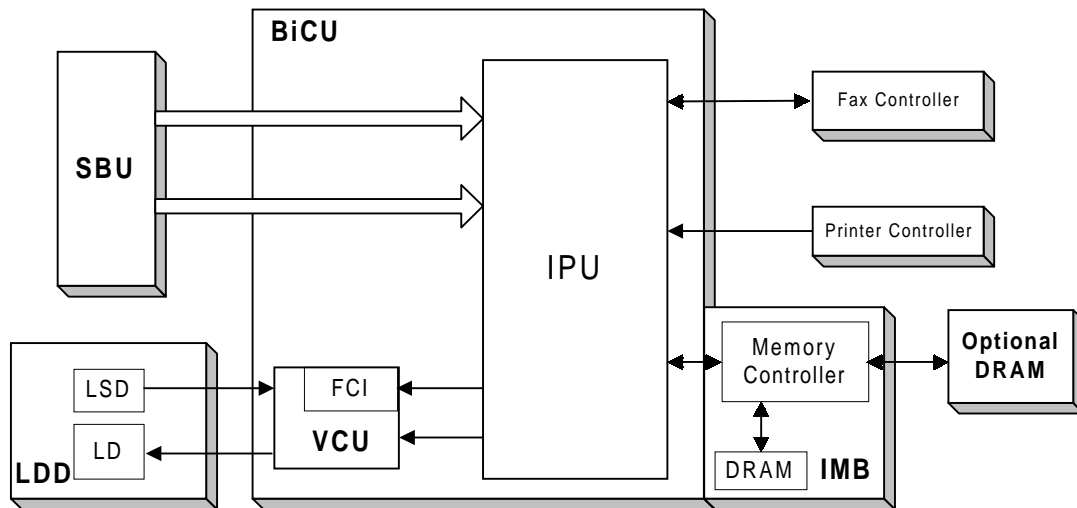

The image data from the SBU goes to the IPU (Image Processing Unit) on the BiCU board, which carries out the following processes on the image data:

1. Auto shading
2. White/black line correction
3. Scanner gamma correction
4. Magnification (Main scan)
5. Filtering (MTF and smoothing)
6. ID gamma correction
7. Binary picture processing
8. Error diffusion
9. Dithering
10. Video path control
11. Test pattern generation

The image data then goes to the VCU.

NOTE: The IPU and VCU are contained in the same IC (called KT-ONE) on the BiCU.

Image Processing Modes

The user can select Text, Photo and Special original types. However, each of these original types has a range of different choices (such as “sharp”, “photographs”, etc), which are listed in the table below.

- All modes can be customized with a range of SP modes that can be adjusted to meet user requirements.
- The user can select the mode that best suits their original with the following user tool: Original Type: User Tools – 3. Copier Features – 3. Adjust Original Mode

Original Type	Mode	Targeted Original Type
Text	Normal	Normal text originals
	Sharp	Newspapers, originals through which the rear side is moderately visible as faint text.
Photo	Photo priority	Text/photo images which contain mainly photo areas
	Text priority	Text/photo images which contain mainly text areas
	Photographs	Actual photographs
Special	Unneeded background	Originals through which the rear side is extremely visible (or have a colored background) with faint text. Also for originals with very grainy backgrounds (some newspapers) and faint text.
	Colored text	Originals with colored text and lines.
	Normal Pixel Photo	Photo images created by dither patterns (dots visible), such as newspaper photos – normal resolution.
	Coarse Pixel Photo	Photo images created by dither patterns (dots visible), such as newspaper photos – coarse resolution.
	Preserved Background (Normal Text)	Use instead of Normal Text if, e.g. an embedded white area causes Auto Image Density to initially remove the surrounding (darker) background but leave the rest. Use if the customer wishes to keep this background.

Detailed Descriptions

IMAGE PROCESSING

Image Processing Path

This diagram shows the various stages of image processing and where they are performed.

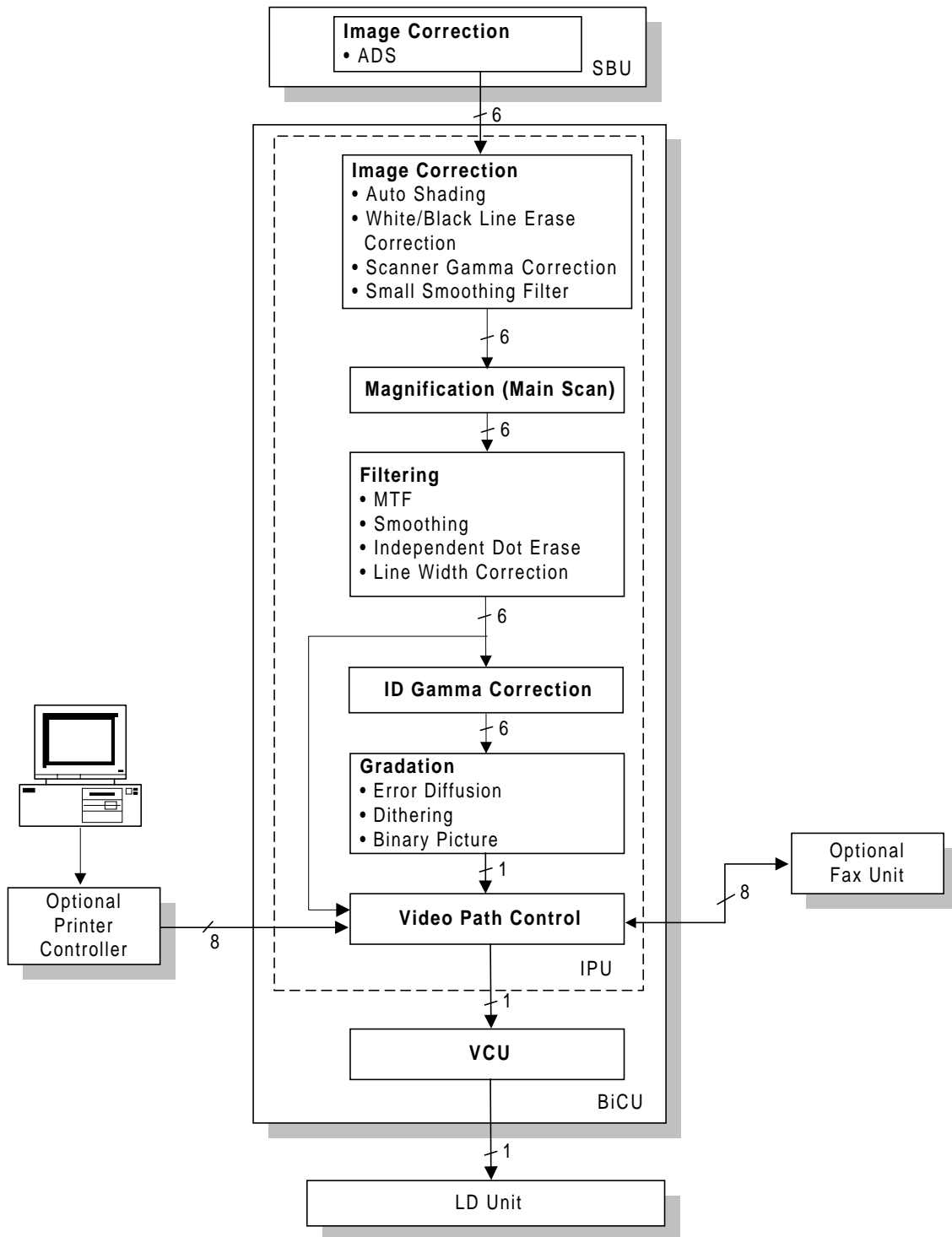

Original Modes

The machine has 10 original modes. There are two text modes, three photo modes, and five “special” modes.

The original mode key on the operation panel has two settings, text and photo. With the default settings, the machine uses “Normal Text (Text 1)” when the Text indicator is lit, and uses “Photo Priority (Photo 1)” when the Photo indicator is lit.

The customer can allocate different modes to the Text and Photo indicators with User Tools – 3. Copier Features – 3. Adjust Original Mode. Note that the Text indicator does not have to be allocated to a Text mode and the Photo key does not have to be allocated to a Photo mode. For example, the Text indicator can be allocated to Photo 3, and the Photo indicator can be allocated to Special 4.

If the user wishes to customize one of the original modes, the technician can change the settings using SP4-922 to SP4-942. Refer to “SP Modes for Each Image Processing Step”. However, only one of the original modes can be customized at any one time.

SP Modes for Each Image Processing Step

The table on the next page shows which SP modes are used for each step of image processing.

- 4-921: Selects **which original mode** the settings from SP4-922 to SP4-928 will be applied to.
- 4-922: Selects the scanner γ curve. You can select either a curve for text-based originals (brings out text) or a curve for photo originals (better distinctions between shades of dark colors).
- 4-923: Selects the central notch position for the ID adjustment LEDs.
- 4-925-001: Adjusts the clarity of line images and the edges of solid images. Also determines the smoothing filter used when the user selects Special 3 or Special 4.
- 4-925-002: Adjusts the clarity of solid image areas.
- 4-925-003: Adjusts the clarity of low ID lines.
- 4-926: Adjusts the texture removal level.
- 4-927: Adjusts the line width.
- 4-928: Selects the dot erase level.
- 4-941: Selects the white line erase level.
- 4-942: Selects the black line erase level.

IMAGE PROCESSING

NOTE: The gray area means the setting cannot be changed using SP mode.

	Text		Photo			Special				Note		
	Normal	Sharp	Photo Priority	Text Priority	Photographs	Unneeded Background	Colored Text	Normal Pixel Photo	Coarse Pixel Photo		Preserved Background	
SBU	ADS	ADS	ADS	ADS		ADS						
↓												
Shading Correction	Shading Line Correction	Enabled	Enabled	Enabled				Enabled				
	White Line Correction			Enabled	Enabled			Enabled			SP4-941	
	Black Line Correction	Enabled (DF only)		Enabled (DF only)				Enabled (DF only)			SP4-942	
	Scanner γ Correction	Text (Reflection Ratio ID Linear)	Text (Reflection Ratio ID Linear)	Text (Reflection Ratio ID Linear)				Text (Reflection Ratio ID Linear)			SP4-922	
↓	Small Smoothing Filter	Weak		Normal				Normal	Strong	Strong	Weak	Connected with MTF filter (Edge)
	Main Scan Magnification	Enabled		Enabled				Enabled				
	Mirroring	Enabled (DF only)		Enabled (DF only)				Enabled (DF only)				
	Side-to-side Registration (Left Side)	Enabled		Enabled				Enabled				
Filtering	MTF Filter (Edge)	Normal	Strong	Weak (All Area)	Normal	Strong	Normal	Normal			Normal	SP4-925-001
	MTF Filter (Solid)		Normal			Normal						SP4-925-002
	MTF Filter (Low ID)	Normal	Normal		Normal		Normal				Normal	SP4-925-003
	Smoothing Filter								Normal			SP4-925-001
	Independent Dot Erase	Weak			Weak		Strong	Weak			Weak	SP4-928
	Line Width Correction	Disabled			Disabled		Disabled	Thick			Disabled	SP4-927
↓												
Graduation	ID γ Correction	Normal	Sharp	Photo Priority	Text Priority	Photographs	Sharp	Normal	Normal Pixel Photo	Coarse Pixel Photo	Preserved Background	SP4-923
	Graduation	Error Diffusion	Binary	Error Diffusion			Binary	Error Diffusion	Dithering (105 Lines)	Dithering (53 Lines)	Error Diffusion	SP4-926 (Error diffusion only)
↓												
Path Control	Video Path Control	Enabled		Enabled				Enabled				
	FCI		Enabled				Enabled					
VCU	Edge Correction									Enabled		
	Printer γ Correction	Enabled		Enabled					Enabled			

Auto Shading

Overview

There are two auto shading methods: black level correction and white level correction. Auto shading corrects errors in the signal level for each pixel.

Unlike previous machines, white level correction is only done when SP4-941 is set to 0, and not by default. However, a process called White Line Erase Compensation is used instead; this process can be adjusted by changing the value of SP4-941 between 1 and 5 (the default setting is 2).

Black level correction is always done.

Black Level Correction

The CPU reads the black dummy data from one end of the CCD signal (32 pixels at the end are blacked off) and takes the average of the black dummy data. Then, the IPU deletes the black level value from each image pixel.

White Level Correction

Previous machines used 8-bit data (256 gradations), but this machine uses 6-bit data (64 gradations). When white level correction is applied to 6-bit data, white lines are more easily generated. This is because the normal variations in CCD pixel response (which are very slight), when rounded off by white level correction, will show up much easier on the copy when the data is divided into 64 gradations.

White level correction is only done when SP4-941 is set to "0" (this is not the default). This is the only setting that will compensate for extremely low (abnormal) pixel response. However, it was judged that under normal conditions, white lines were more likely to occur (due to the above reason) and have a larger effect on the copy.

Before scanning the original, the machine reads a reference waveform from the white plate. The average of the white video level for each pixel is stored as the white shading data in the FIFO memory in the IPU (KT-ONE) chip.

The video signal information for each pixel obtained during image scanning is corrected by the IPU (KT-ONE) chip.

Auto shading is done before scanning for the first original as well as after scanning each page to prepare for the next page.

If the image density or the original mode is changed during a copy run, auto shading is done before scanning the next original.

White Line Erase

Since this machine does not apply white level correction as default, white lines are automatically minimized (the reason is explained above). However, with no white level correction, the images on the edges of the copy would always appear darker than those in the center. This is because the CCD elements on the edges receive less light. Therefore to compensate, SP4-941 can be used to control both the uniformity of the edge/center image density and to minimize white lines. However, it is a trade-off between the two:

SP4-941 applies the correction only to the output from the central CCD elements only, keeping the output from the edge elements constant (as the standard). With a setting of 1, a large amount of correction is applied and the central areas are uniform with the edges. However white lines are relatively visible. With the maximum setting (5), no correction is applied and the central areas appear lighter than the edges (true to the original CCD data). However white lines are minimized.

Note that if SP4-941 is set to 0, white line erase is not used, and white level correction is used instead.

Black Line Erase

In ADF mode, if extremely low CCD output is detected on the scanning line before the leading edge of original arrives there, this is attributed to abnormal black dots on the exposure glass. This low output is corrected using neighboring pixels. To adjust or switch off this correction, use SP4-942.

Scanner Gamma (γ) Correction

The CCD output is not proportional to the quantity of light received. Scanner γ correction corrects the CCD output so that grayscale data is proportional to the quantity of light received.

The machine has two possible scanner gamma curves: *Text* and *Photo*. As the default setting, *Text* is used in all modes (SP4-922). When selecting *Text*, the machine does not use scanner γ correction. As a result, the output is darker than the image density on the original. The advantage of this is that the machine can bring out lower density black areas. The disadvantage is that the machine cannot bring out gradations in darker areas, i.e. differences in shades of dark colors are hard to distinguish.

When selecting *Photo*, the machine uses scanner γ correction. One advantage of this is that the machine can bring out gradations in dark areas of photo image originals. The disadvantage is that it in some cases images come out lighter than the customer desires.

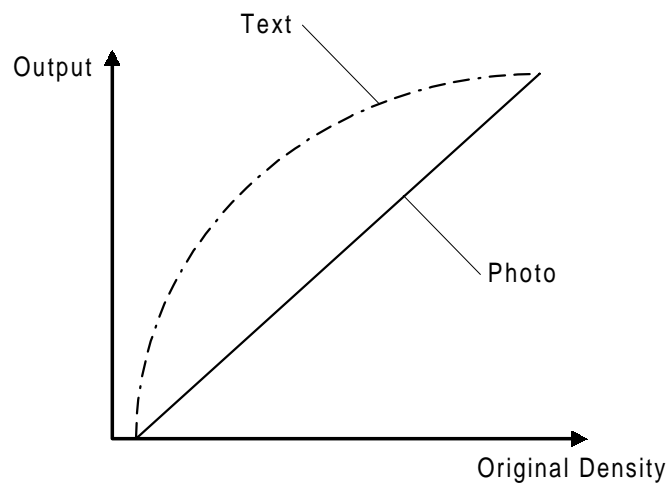

Main Scan Magnification

Changing the scanner speed enables enlargement and reduction along the sub scan direction. However, enlargement and reduction along the main scan direction is handled by the IPU (KT-ONE) chip. The processing for main scan enlargement/reduction is the same as in previous digital machines.

Mirroring for ADF Mode

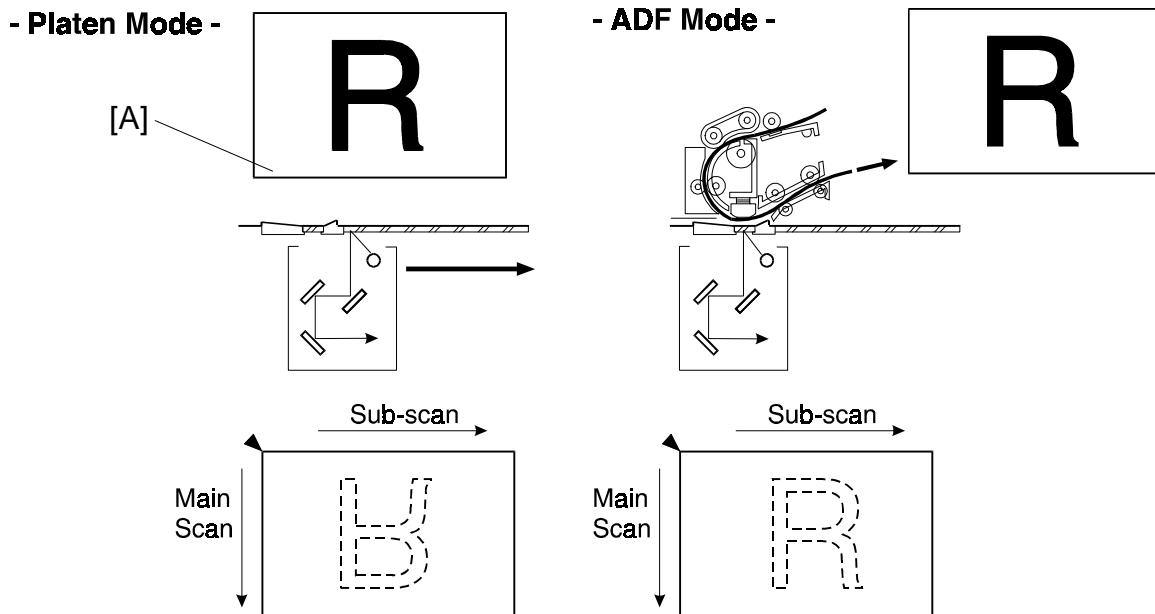

When making copies using the ADF, the magnification circuit creates a mirror image. This is because the scanning start position along the main scan direction in ADF mode is at the opposite corner of platen mode.

In platen mode, the original is placed face down on the exposure glass. The main scan start position is at corner [A], and the scanner moves down the page. In ADF mode, the ADF feeds the leading edge of the original to the DF exposure glass. Therefore as mentioned above, the main scan start position will be at the opposite corner.

To create the mirror image, the IPU stores each line in LIFO (Last In First Out) memory.

Filtering

Overview

There are several software filtering processes for enhancing the desired image qualities of the selected original mode. There are three MTF filters, a smoothing filter, independent dot erase, and line width correction. Each can be used only when certain modes are selected (details below) and are automatically applied.

The strength levels for the MTF and smoothing filters are controlled by SP4-925. The levels for independent dot erase and line width correction are controlled by SP4-927 and 4-928, respectively.

The MTF filters bring out sharpness. The three MTF filters are Edge, Solid Image and Low ID Line. Independent dot erase removes unwanted dots from the image. Line width correction adjusts the line width.

MTF Filter Adjustment - Edge

In order to determine whether a given dot is part of an edge or not, the IPU checks all surrounding dots (vertical, horizontal, and diagonal). If the IPU determines that the dot is part of an edge, the machine applies the MTF filter for edges, using the value set in SP4-925-001. The higher the setting, the sharper the image. However, this is only used when the customer uses Text 1, Text 2, Photo 1-3, Special 1, Special 2, or Special 5.

The default value is "0" for each mode. However the actual strength of "0" differs from mode to mode.

MTF Filter Adjustment - Solid

If the IPU detects that the dot is not part of an edge, the machine applies the MTF filter for solid areas using the value set in SP4-925-002. The higher the setting, the sharper the image. However, this is only used when the customer uses Text 2 or Special 1.

The default value is "0" for each mode. However the actual strength of "0" differs from mode to mode.

MTF Filter Adjustment - Low ID Line

The IPU also checks the image density of all dots. If a succession of low-density dots is detected, the machine interprets this as a low ID line and applies the MTF filter for low ID lines, using the value set in SP4-925-003. The higher the setting, the sharper the image. However, this is only used when the customer uses Text 1, Text 2, Photo 2, Special 1, Special 2, or Special 5.

The default value is "0" for each mode. However the actual strength of "0" differs from mode to mode.

IMAGE PROCESSING

Smoothing Filter Adjustment

The machine will apply the smoothing filter when the user selects Special 3 or 4 (Dithering), using the value in SP4-925-001. Note that this SP is also used when the machine applies the MTF Filter for Edges (see above). The higher the setting, the sharper the image.

The default value is "0" for each mode. However, the actual strength of "0" differs from mode to mode.

Independent Dot Erase

When the user selects Text 1 and 2, Photo 2, and Special 1, 2, and 5 modes, independent dots are detected using a matrix and erased from the image. The detection level can be adjusted with SP4-928.

The higher setting, the greater number of dots the machine will erase. The machine erases the dots regardless of their image density. However, note that dots in mesh-like images may be mistakenly detected as independent dots.

Line Width Correction

When the user selects Text 1 and 2, Photo 2, Special 1, 2, and 5, the thickness of lines is adjusted using the setting of SP4-927. Note that the default for all modes except Special 2 is OFF.

The higher the setting, the thicker the line. However note that Special 2 starts with a thickness value higher than normal line thickness, whereas the others begin at normal line thickness. So even if Special 2 is set to -2, the lines will still come out thicker than normal.

Line width correction is done by the IPU (KT-ONE) chip.

ID Gamma (γ) Correction

The machine automatically selects the most appropriate ID gamma correction based on the selected original type, the user tool Image Adjustment setting and the operation panel ID setting. Except for Special 1 and 2, each original mode has its own ID gamma correction type. Special 2 uses the same type as Text 1, and Special 1 uses the same type as Text 2.

In all modes, ID gamma correction can be adjusted with SP4-923.

Gradation Processing

Overview

There are three types of gradation processing (listed below). Refer to the “Default Image Processing Mode for Each Original Type” section for more details on which processes are used for each original mode.

- Binary picture processing
- Error diffusion
- Dithering

Binary Picture Processing

The 6-bit image data is converted into 1-bit data (black and white image data). This is done when the user selects Text 2 or Special 1. The threshold for deciding whether a pixel is black or white cannot be adjusted.

Error Diffusion

Error diffusion reduces the difference in contrast between light and dark areas of a halftone image. Each pixel is corrected using the difference between it and the surrounding pixels. The corrected pixels are compared with an error diffusion matrix.

Error diffusion is applied when the user selects Text 1, Photo 1-3 and Special 2 and 5.

As the final step in error diffusion, a process called Texture Removal is applied to Text 1, Special 2, and Special 5 by default, but can also be applied to Photo 1-3 by changing the value of SP4-926.

Texture removal uses 64 threshold values in an 8 x 8 matrix. The value of SP4-926 controls the application of Texture Removal for each of the 5 modes listed above. The settings are as follows:

- 0: The default value for each mode is used. Text 1, Special 2, and Special 5 have a default of 3 (see below) and Photo 1-3 have a default of 1.
- 1: No removal applied.
- 2 – 5: Removal applied at the level specified here. The higher the setting (level), the less clear the image will become (more texture removal).

Dithering

Each pixel is compared with the threshold in a dither matrix. Several matrices are available to bring out half-tone areas in images such as newspaper-type photographs. Dithering is only used for Special 3 and Special 4.

6.1.5 IMB (MEMORY CONTROLLER AND DRAM)

The functions of the these two IMB component devices are as follows:

Memory Controller: Compression of the 1-bit image data
 Image rotation
 Image data transfer to the DRAM

DRAM (16MB): Stores the compressed data
 Processing area

The data goes to the memory controller after binary picture/grayscale processing. The data is first compressed and then stored in the DRAM. For printing, the data from the DRAM goes back to the memory controller, where it is decompressed and goes through image editing (e.g., image rotation, repeat image).

When the 16 and 32 MB memory is installed on the BiCU board, the memory capacity changes as follows:

A4 size, Text mode (Number of pages)

	0 MB	16 MB	48 (16+32) MB
A4 6%	0	71	99
ITU-T#4 (12% black)	0	34	99

NOTE: The amount of standard memory depends on the model:
 B039: North America (16MB standard), Others (no standard memory).
 B040, B043: 16MB standard.

6.1.6 VIDEO CONTROL UNIT (VCU)

Fine Character and Image (FCI)

The FCI performs image smoothing. This functions only affects binary picture processed images for certain original modes.

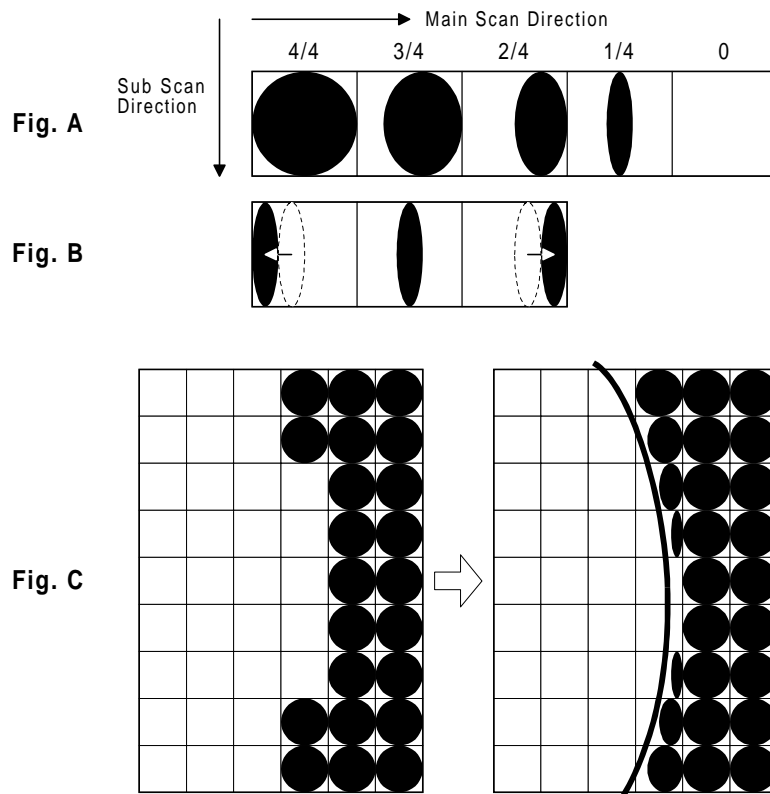

Usually, binary picture processing generates jagged edges on characters, as shown in the above illustration. These are reduced using edge smoothing. The FCI changes the laser pulse duration and position for certain pixels.

Fig. A shows the four possible pulse durations, and Fig. B shows how the laser pulse can be in one of three positions within the pixel. Fig. C shows an example of how edge smoothing is used.

FCI smoothing is only effective when Text 2 or Special 1 is selected. There is no SP adjustment for this.

Printer Gamma Correction

Printer correction corrects the data output from the IPU to the laser diode to account for the characteristics of the engine components (e.g. drum, laser diode, lenses).

The machine chooses the most suitable gamma curve for the original type selected by the user. There is no SP adjustment for this.

Detailed Descriptions

6.6 LASER EXPOSURE

6.6.1 OVERVIEW

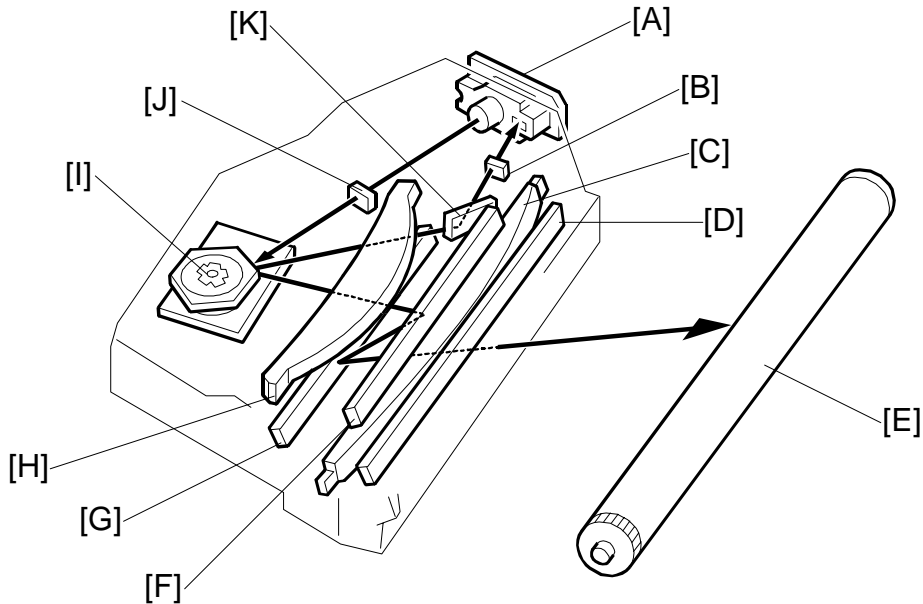

- | | |
|------------------------------------|--------------------------------------|
| [A]: LD unit | [G]: 2nd mirror |
| [B]: Synchronization detector lens | [H]: F-theta lens |
| [C]: Double toroidal lens | [I]: Polygon mirror |
| [D]: Shield glass | [J]: Cylindrical lens |
| [E]: OPC drum | [K]: Synchronization detector mirror |
| [F]: 1st mirror | |

- The LD drive board controls both the laser output and laser synchronization mechanism.
- The machine cuts off the power supply to the LD drive board if the front or right cover is opened.

6.6.2 AUTO POWER CONTROL (APC)

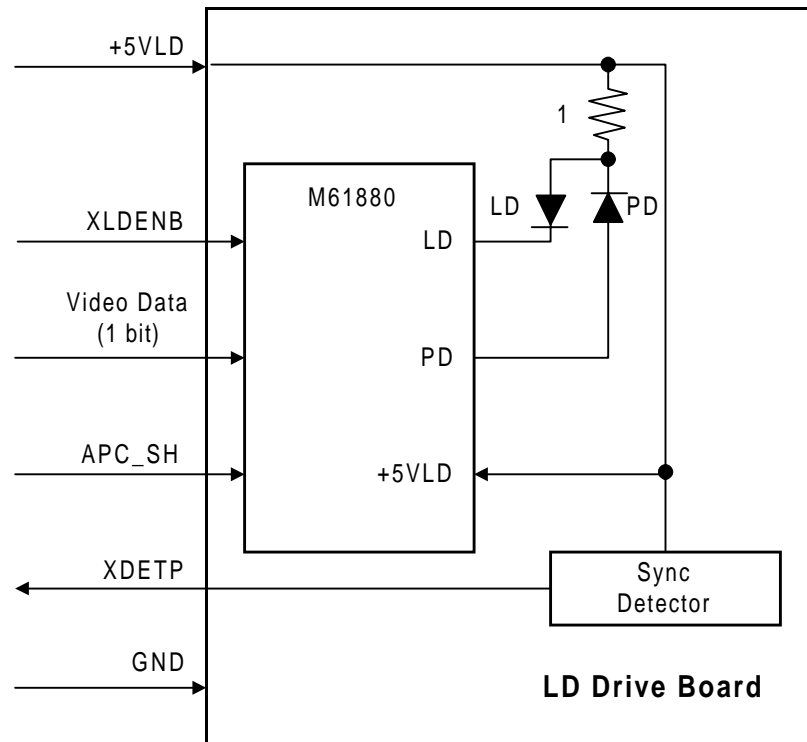

The LD driver IC drives the laser diode. To prevent the intensity of the laser beam from changing because of the temperature, the machine monitors the current passing through the laser diode (LD). The machine adjusts the current to the laser diode by comparing it with the reference level from the reference circuit. This auto power control is done just after the machine is turned on and during printing.

The laser diode power is adjusted on the production line.

NOTE: Do not touch the variable resistors on the LD unit in the field.

6.6.3 LD SAFETY SWITCH

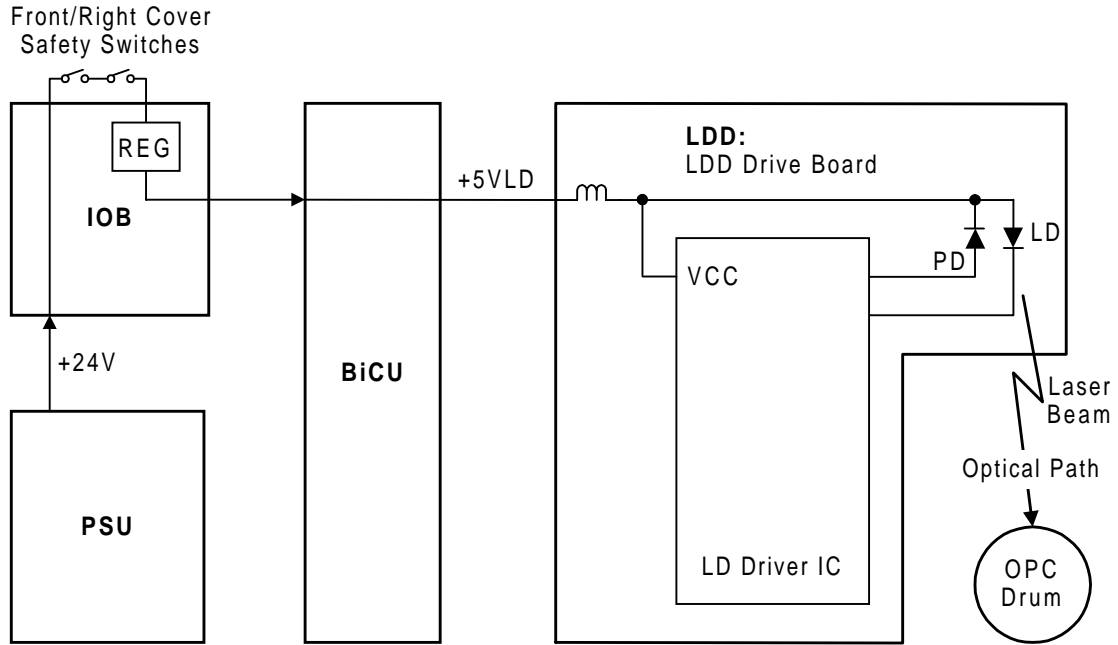

To ensure technician and user safety and to prevent the laser beam from inadvertently switching on during servicing, there are safety switches at the front and right covers.

When the front cover or the right cover is opened, the power supply to the laser diode is interrupted.

The switches are installed on the +24V line coming from the power supply unit, then the +5VLD is generated from the +24V supply after it goes through the interlock switches.

6.7 PHOTOCONDUCTOR UNIT (PCU)

6.7.1 OVERVIEW

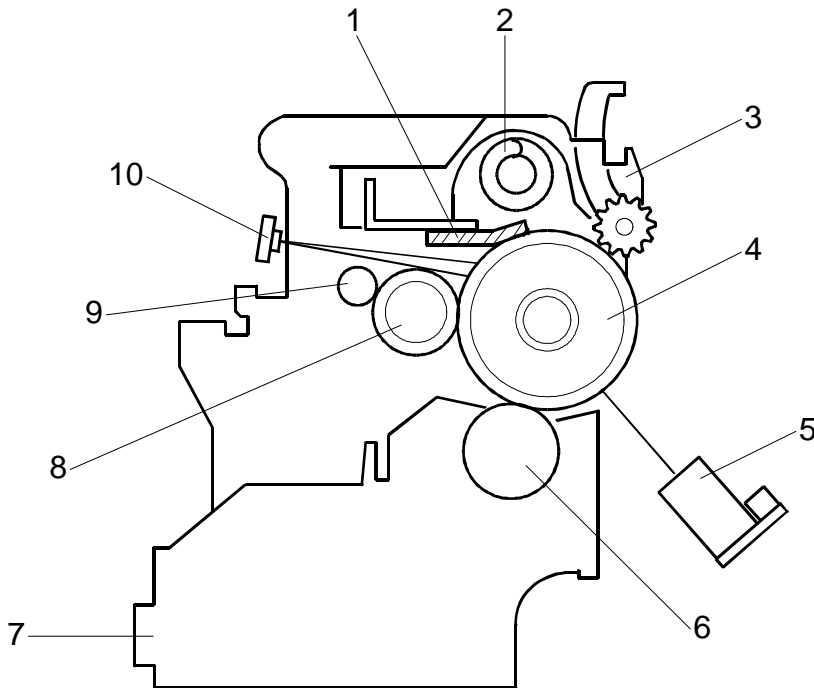

The PCU consists of the components shown in the above illustration. An organic photoconductor (OPC) drum (diameter: 30 mm) is used in this machine.

- | | |
|--------------------------|---------------------------------|
| 1. Cleaning Blade | 6. Development Roller |
| 2. Toner Collection Coil | 7. Development Unit |
| 3. Pick-off Pawl | 8. Charge Roller |
| 4. OPC Drum | 9. Charge Roller Cleaning Brush |
| 5. ID Sensor (see note) | 10. Quenching Lamp (see note) |

NOTE: The ID sensor and quenching lamp are not included in the PCU.

PHOTOCONDUCTOR UNIT (PCU)

6.7.2 DRIVE

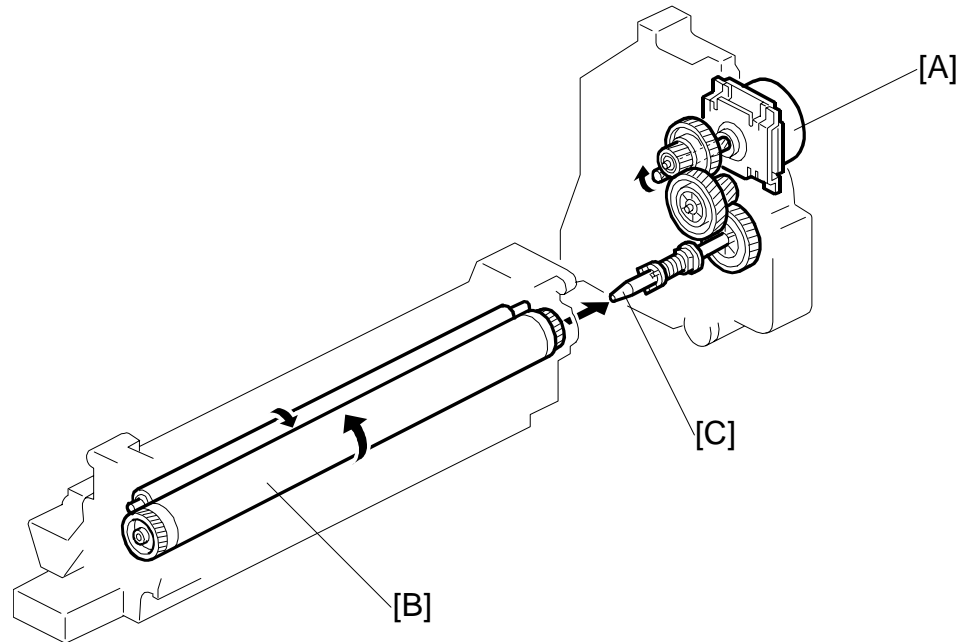

The main motor [A] drives the drum [B] through a series of gears and the drum drive shaft [C]. The main motor assembly includes a drive controller, which outputs a motor lock signal when the rotation speed is out of the specified range.

6.8 DRUM CHARGE

6.8.1 OVERVIEW

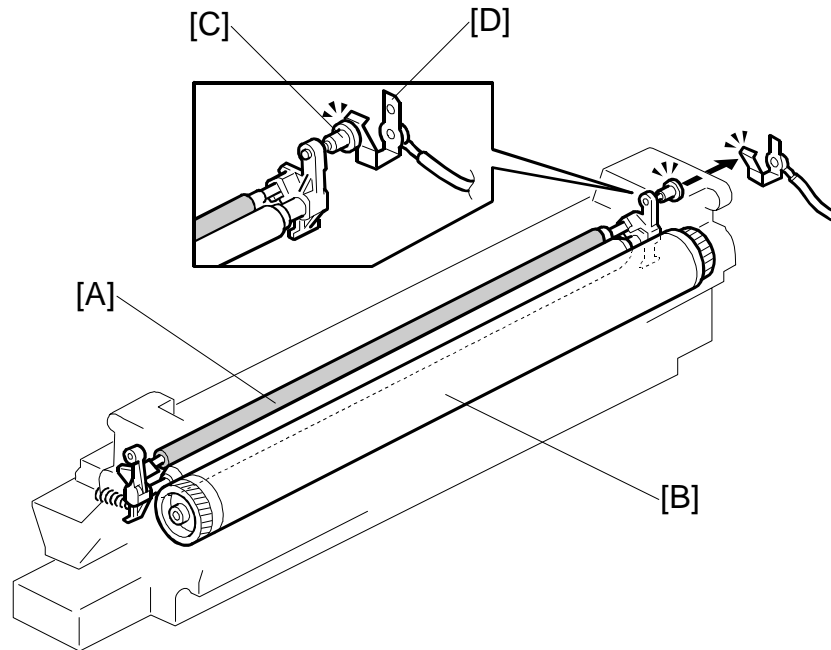

This copier uses a drum charge roller to charge the drum. The drum charge roller [A] always contacts the surface of the drum [B] to give it a negative charge of -950 V.

The high voltage supply board gives a negative charge of -1700 V to the drum charge roller through the screw [C] and terminal plate [D]. This voltage can be changed using SP2-001-1.

6.8.2 CHARGE ROLLER VOLTAGE CORRECTION

Correction for Environmental Conditions

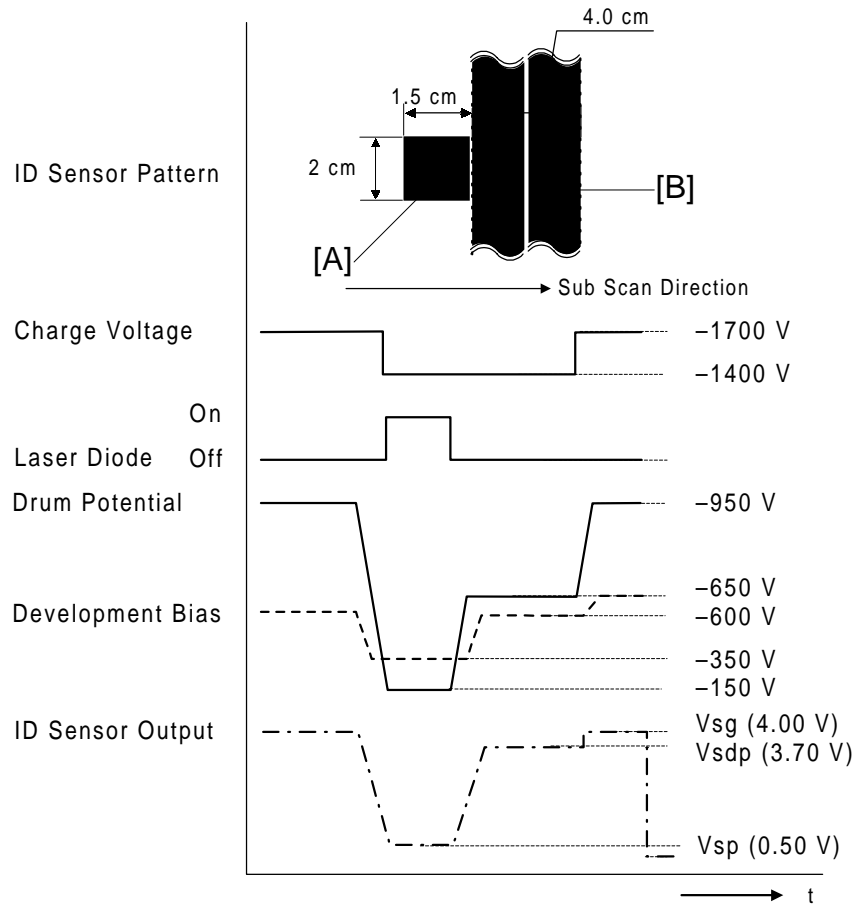

With a drum charge roller system, the voltage transferred from roller to drum varies with the temperature and humidity around the drum charge roller. The higher the temperature or humidity is the higher the applied voltage required.

To compensate, the machine uses the ID sensor to measure the effects of current environmental conditions. For this measurement, the process control parameters are balanced so that any small change in drum potential caused by environmental effects is reflected in a change in the amount of toner transferred to the drum.

This measurement is made immediately after the ID sensor pattern for toner density control. Immediately after making ID sensor pattern [A], the charge roller voltage stays the same, but the development bias goes up to -600 V; as a result the drum potential is reduced to -650 V. The laser diode is not switched on, and the drum potential is now slightly higher than the development bias, so a very small amount of toner transfers to the drum. The ID sensor measures the density of this pattern [B], and the output voltage is known as Vsdp. This voltage is compared with Vsg (read from the bare drum at the same time).

If the humidity drops, the drum potential goes up (to a higher –ve voltage) even if the charge roller voltage supply stays the same (efficiency of voltage transfer is higher with lower humidity). As a result, less toner is transferred to ID sensor pattern [B]. If the sensor output reaches a certain point, the drum charge voltage will be reduced.

To determine whether to change the drum charge roller voltage, the machine compares V_{sdp} with V_{sg} .

- $V_{sdp}/V_{sg} > 0.95$ = Make the drum charge voltage less –ve (smaller) by 50 V
- $V_{sdp}/V_{sg} < 0.90$ = Make the drum charge voltage more –ve (larger) by 50 V

6.8.3 ID SENSOR PATTERN PRODUCTION TIMING

The ID sensor pattern is not made every page or every job.

It is only made in the following conditions:

- During warm-up at power on
- If the machine starts warming up after a certain time (default: 90 minutes) has passed since entering night/off mode or low power mode.
The 90-minute interval can be changed using SP2-995.

DRUM CHARGE

6.8.4 DRUM CHARGE ROLLER CLEANING

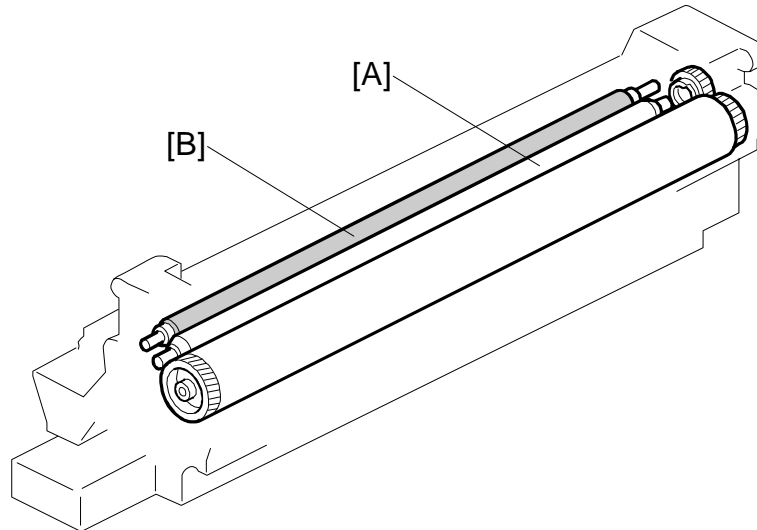

Because the drum charge roller [A] always contacts the drum, it gets dirty easily. So, the cleaning brush [B] also contacts the drum charge roller all the time to clean the surface of the drum charge roller.

6.9 DEVELOPMENT

6.9.1 OVERVIEW

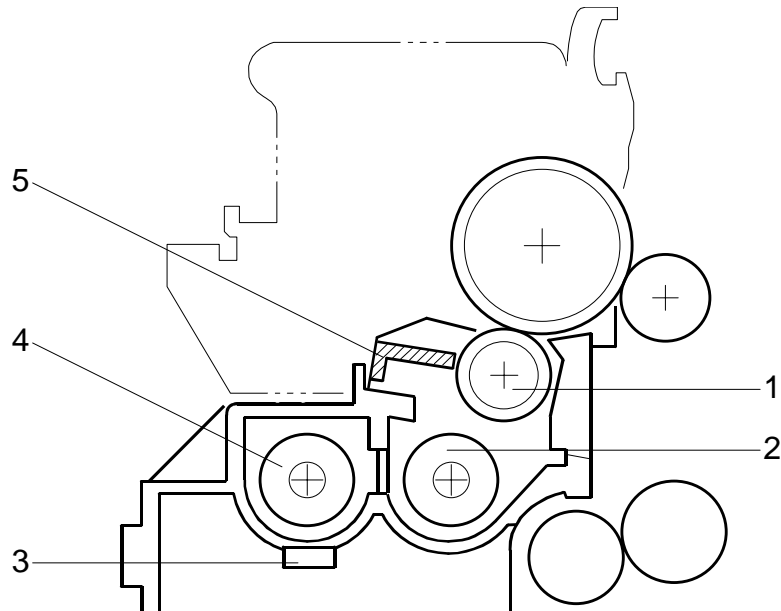

The development unit consists of the following parts.

- | | |
|-----------------------|-------------------|
| 1. Development roller | 4. Mixing auger 1 |
| 2. Mixing auger 2 | 5. Doctor blade |
| 3. TD sensor | |

This machine uses a single-roller development system. Two mixing augers mix the developer. The toner density (TD) sensor and image density (ID) sensor (see the illustration in the PCU section) are used to control the image density on the copy.

DEVELOPMENT

6.9.2 DRIVE

The main motor [A] drives the development roller [B] and mixing augers [C] through a train of gears and the development drive shaft [D]. When the PCU is pushed in, the development drive shaft engages the development roller gear.

The development drive gears (except for the gears in the development unit) are helical gears. These gears are quieter than normal gears.

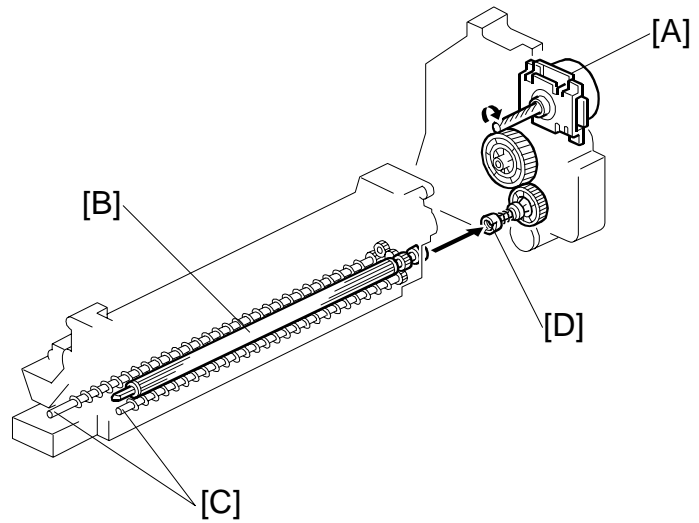

6.9.3 DEVELOPER MIXING

The two mixing augers, [E, F] keep the developer evenly mixed. Mixing auger 2 [E] transports excess developer, scraped off the development roller [G] by the doctor blade [H], towards the front of the machine. Mixing auger 1 [F] returns the excess developer, along with new toner, to the rear of the mixing assembly. Here the developer is reapplied to the development roller.

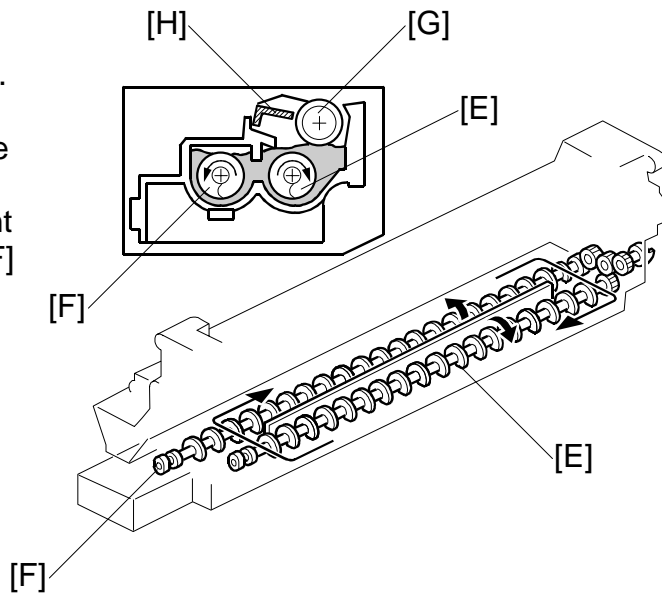

6.9.4 DEVELOPMENT BIAS

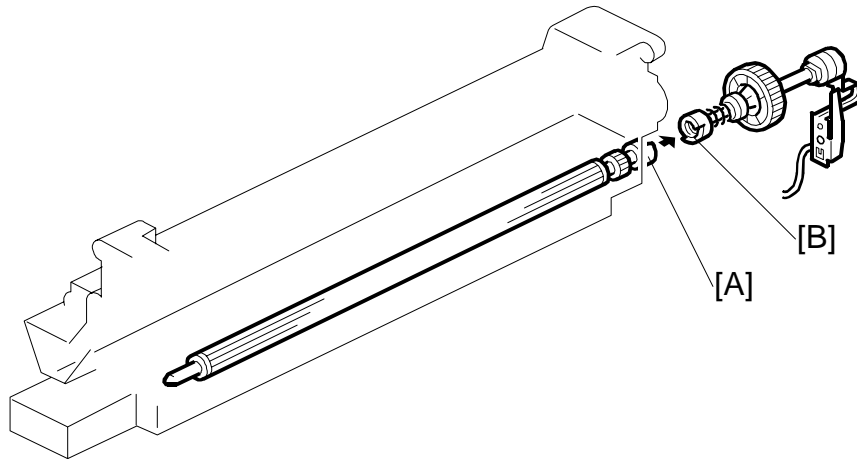

This machine uses a negative-positive development system, in which black areas of the latent image are at a low negative charge (about -154 ± 50 V) and white areas are at a high negative charge (about -950 V).

To attract negatively charged toner to the black areas of the latent image on the drum, the high voltage supply board applies a bias of -650 volts to the development rollers throughout the image development process. The bias is applied to the development roller shaft [A] through the drive shaft [B].

The development bias voltage (-650 V) can be adjusted with SP2-201-1.

6.9.5 TONER SUPPLY

Toner Bottle Replenishment Mechanism

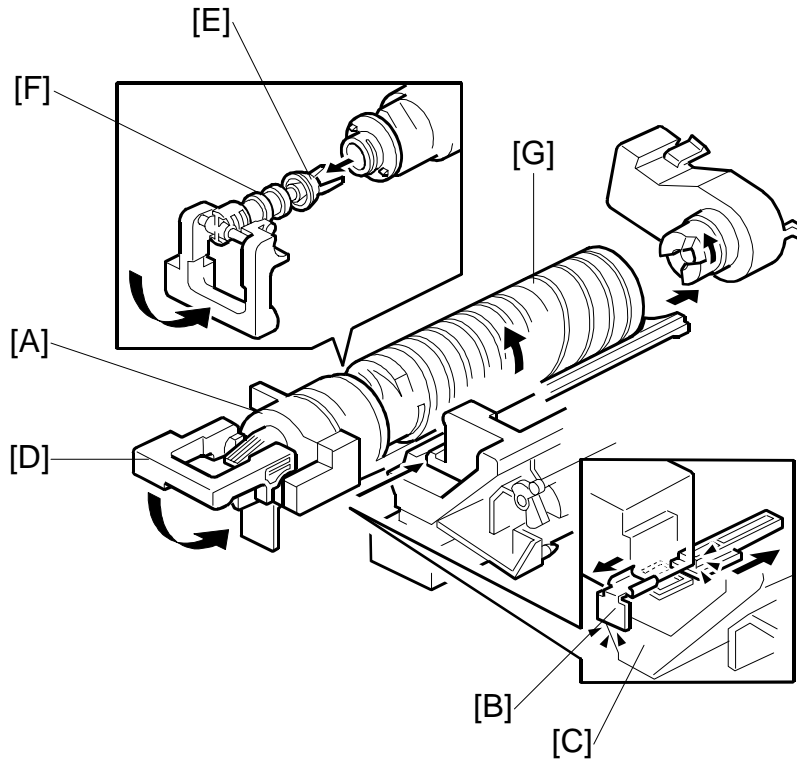

When a toner bottle is placed in the bottle holder unit [A] and the unit is pushed in completely, toner shutter [B] moves against the side [C] of the PCU. When the toner bottle holder lever [D] is put back in the original position, the cap [E] on the toner bottle is pulled away and kept in place by the chuck [F].

The toner supply mechanism transports toner from the bottle to the development unit. The toner bottle has a spiral groove [G] that helps move toner to the development unit.

When the toner bottle holder is released, the chuck releases the toner bottle cap into its proper position to prevent toner from scattering.

When the bottle holder unit is pulled out to add a new toner bottle, the toner shutter shuts to block the opening as a result of pressure from a spring.

Toner Supply Mechanism

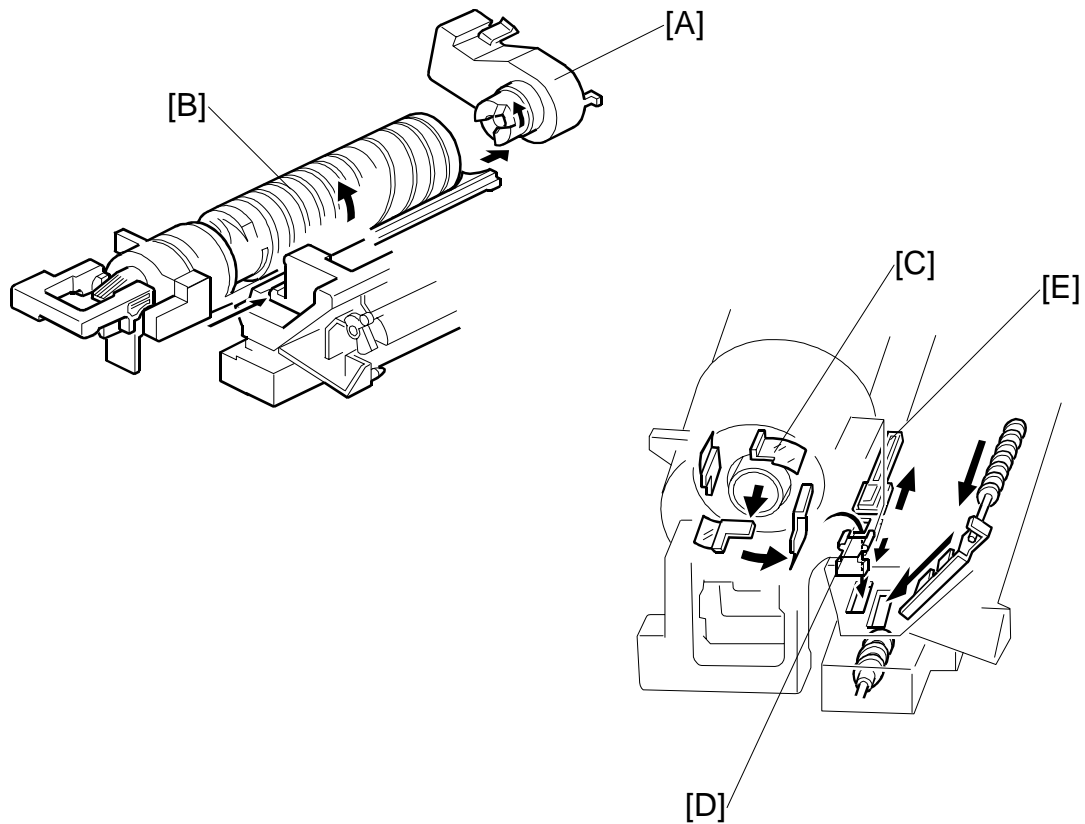

The toner supply motor [A] drives the toner bottle [B] and the mylar blades [C]. First, the toner falls down into the toner bottle holder. The toner supply mylar blades transfer the toner to the slit [D]. When the PCU is installed in the machine, the shutter [E] above the PCU is opened by the toner bottle holder. Then the toner falls down into the development unit through the slit and the shutter.

6.9.6 TONER DENSITY CONTROL

Overview

There are four modes for controlling toner supply as shown in the following tables, which can be changed with by SP2-921. The factory setting is sensor control 1 mode.

Basically, the toner concentration in the developer is controlled using the standard TD sensor voltage (V_t s), toner supply reference voltage (V_{ref}), actual TD sensor output voltage (V_t), and ID sensor output data (V_{sp}/V_{sg}).

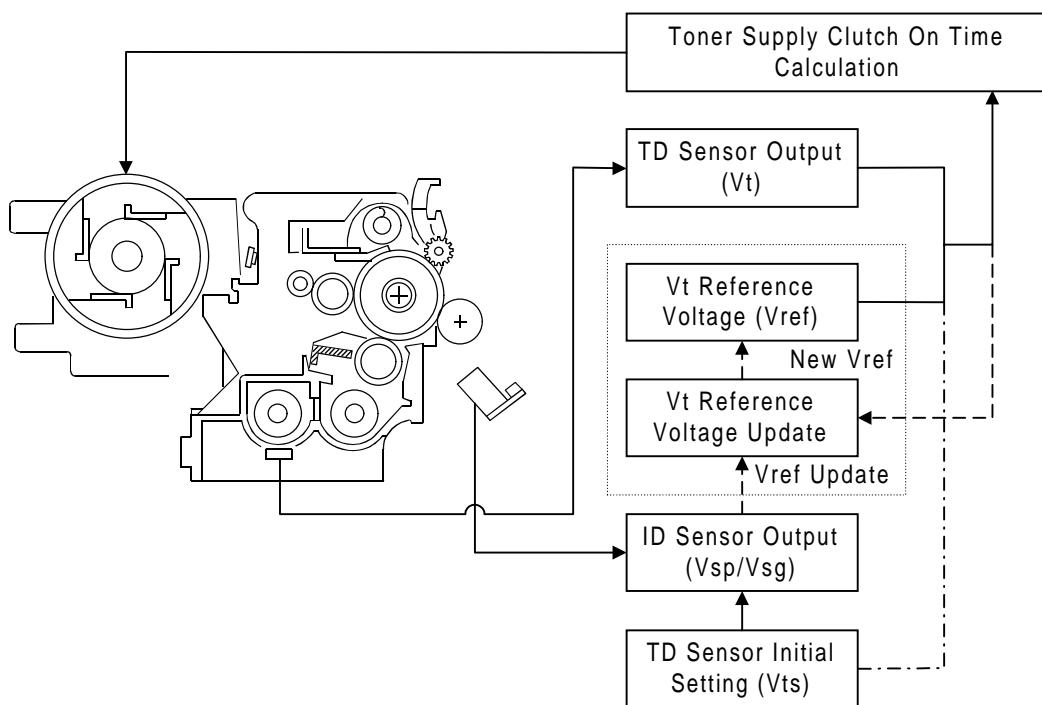

The four toner density control modes are as follows.

Mode	Sensor control 1 (SP2-921, "0"): Normally use this setting only
Toner supply decision	Compare V_t with a reference voltage (V_{ts} or V_{ref})
Toner control process	Toner is supplied to the development unit when V_t is higher than the reference voltage (V_{ts} or V_{ref}). This mode keeps the V_{ref} value for use with the next toner density control. V_{ts} is used for the first toner density control after a new PCU has been installed, until it has been corrected with the ID sensor output. V_{ref} is used after V_{ts} has been corrected with the ID sensor output voltage (corrected during the first toner density control for a new PCU).
Toner supply amount	Varies
Toner end detection	Performed

Mode	Sensor control 2 (SP2-921, "1"): For designer's use only; do not use in the field
Toner supply decision	Compare V_t with a reference voltage (V_{ts})
Toner control process	This toner control process is the same as sensor control 1 mode. However, the reference voltage used is always V_{ts} .
Toner supply amount	Varies
Toner end detection	Performed

Mode	Fixed control 1 (SP2-921, "2"): For designer's use only; do not use in the field
Toner supply decision	Compare V_t with a reference voltage (V_{ts} or V_{ref})
Toner control process	This toner control process is the same as sensor control 1 mode.
Toner supply amount	Fixed (SP2-925)
Toner end detection	Performed

Mode	Fixed control 2 (SP2-921, "3"): Use temporarily if the TD sensor needs to be replaced
Toner supply decision	None
Toner control process	Toner is supplied every printed page regardless of V_t .
Toner supply amount	Fixed (SP2-925)
Toner end detection	Not performed

DEVELOPMENT

Toner Density Sensor Initial Setting

The TD sensor initial setting (SP2-214: Developer Initialize) procedure must be done after replacing the developer. During TD sensor initial setting, the TD sensor is set so that the TD sensor output is the value of SP2-926 (default: 2.4 V). This value will be used as the standard reference voltage (V_{ts}) of the TD sensor.

Toner Concentration Measurement

The toner concentration in the developer is detected once every copy cycle. The sensor output voltage (V_t) during the detection cycle is compared with the standard reference voltage (V_{ts}) or the toner supply reference voltage (V_{ref}).

V_{sp}/V_{sg} Detection

The ID sensor detects the following voltages.

- V_{sg} : The ID sensor output when checking the drum surface
- V_{sp} : The ID sensor output when checking the ID sensor pattern

In this way, the reflectivity of both the drum surface and the pattern on the drum are checked, compensating for any variations in the reflectivity of the pattern on the drum or the reflectivity of the drum surface.

The ID sensor pattern is made on the drum by the charge roller and laser diode.

V_{sp}/V_{sg} is not detected every page or job; it is detected at the following times to decide V_{ref} .

- During warm-up at power on
- If the machine starts warming up after a certain time (default: 90 minutes) has passed since entering night mode or low power mode
The 90-minute interval can be changed using SP2-995.

Toner Supply Reference Voltage (V_{ref}) Determination

The toner supply reference voltage (V_{ref}) is used for toner supply determination (see below). V_{ref} is determined using the following data:

- ID sensor output (V_{sp}/V_{sg})
- (V_{ts} or the current V_{ref}) - V_t

Toner Supply Determination

The reference voltage (V_{ts} or V_{ref}) is the threshold voltage for determining whether or not to supply toner. If V_t becomes greater than the reference voltage, the machine supplies additional toner.

This can be checked using SP2-220.

Toner Supply Motor On Time Determinations

For fixed control mode, the toner supply motor on time is specified by the setting of SP2-925, and does not vary. The default setting is 200 ms for each copy. The toner supply motor on time for each value of SP2-925 is as follows.

Value of SP2-925	Motor On Time (t = 200 ms)
0	t
1	2t
2	4t
3	8t
4	12t
5	16t
6	Continuously
7	Not supplied

For sensor control modes 1 and 2, the toner supply motor on time is decided by the following factors.

- Vt
- Vref or Vts
- TD sensor sensitivity (coefficient: S, value is 0.4)

There are seven levels for toner supply motor on time as shown below.

Level	Decision	Motor On Time (seconds)
1	$(V_{ts} \text{ or } V_{ref}) < V_t \leq (V_{ts} \text{ or } V_{ref}) + S/16$	t (0.4)
2	$(V_{ts} \text{ or } V_{ref}) < V_t \leq (V_{ts} \text{ or } V_{ref}) + S/8$	t x 2 (0.8)
3	$(V_{ts} \text{ or } V_{ref}) < V_t \leq (V_{ts} \text{ or } V_{ref}) + S/4$	t x 4 (1.6)
4	$(V_{ts} \text{ or } V_{ref}) < V_t \leq (V_{ts} \text{ or } V_{ref}) + S/2$	t x 8 (3.2)
5	$(V_{ts} \text{ or } V_{ref}) < V_t \leq (V_{ts} \text{ or } V_{ref}) + 4S/5$	t x 16 (6.4)
6	$V_t \geq (V_{ts} \text{ or } V_{ref}) + 4S/16$ (near-end)	T (30); see note 3
7	$V_t \geq (V_{ts} \text{ or } V_{ref}) + S$ (toner end)	T (30); see note 3

- NOTE:** 1) The value of “t” can be changed using SP2-922 (default: 0.4 second)
 2) The value of “T” can be changed using SP2-923 (default: 30 seconds)
 3) T (30) means that toner is supplied intermittently in a 1/3 duty cycle (1 s on, 2 s off) for 30 seconds

6.9.7 TONER SUPPLY IN ABNORMAL SENSOR CONDITIONS

ID Sensor

Readings are abnormal if any of the following conditions occur:

- $V_{sg} \leq 2.5V$
- $V_{sg} < 3.5V$ when maximum power (979) is applied
- $V_{sp} \geq 2.5V$
- $(V_{sg} - V_{sp}) < 1.0V$
- $V_t \geq 4.5V$ or $V_t \leq 0.2V$

The above ID sensor values can be checked using SP2-221.

When this is detected, the machine changes the value of V_{ref} to 2.5 V then does the toner density control process (in a similar way to sensor control mode 2).

No SC code is generated if the ID sensor is defective.

TD Sensor

The TD sensor output is checked every copy. If the readings from the TD sensor become abnormal, the machine changes the toner density control mode to fixed supply mode 2, and the toner supply amount per page is always 200 ms, regardless of the value of SP2-925. If the machine detects the TD sensor error condition 10 times consecutively, an SC code is generated (SC390) and the machine must be repaired.

6.1.8 TONER NEAR END/END DETECTION AND RECOVERY

The toner near end and end conditions are detected using the V_t and V_{ref} values, in a similar way to toner density control.

This is done in all toner supply modes except for fixed mode 2, when toner end is not detected.

Toner Near End Detection

If V_t is at level 6 (see the table on the previous page) five times consecutively, the machine enters the toner near end condition and the toner end indicator starts blinking. Then the machine supplies toner for a certain time, which depends on the setting of SP2-923 (see the previous page).

Toner Near End Recovery

If the machine detects " $V_t < (V_{ref} \text{ or } V_{ts}) + 4S/5$ " twice consecutively in any of the following situations, the machine clears the toner near end condition.

- While in the toner recovery cycle (supplying toner on and off for 30 s—see the previous page) after the machine has detected a toner near end condition.
- During copying in the toner near end condition.
- If the front cover is opened and closed for more than 10 seconds while a toner near end condition exists.

Toner End Detection

There are two situations for entering the toner end condition.

- When V_t is level 7 three times consecutively, the machine enters the toner end condition.
- When " $V_{t+S} > V_t > (V_{ref} \text{ or } V_{ts}) + 4S/5$ " is detected in the toner near end condition. Following this, 50 copies can be made (the number of copies between this condition and toner end can be changed using SP2-213).

Toner End Recovery

While turning on the main switch, if the front cover is opened for 10 seconds or more and then closed while a Toner End condition exists (following toner bottle replacement), the machine clears the Toner End condition. The recovery procedure is the same as for toner near end. It takes about two minutes.

6.10 DRUM CLEANING AND TONER RECYCLING

6.10.1 DRUM CLEANING

The cleaning blade [A] removes any toner remaining on the drum after the image is transferred to the paper. This model uses a counter blade system.

The cleaning blade scrapes off toner remaining on the drum. When toner builds up in the cleaning unit, toner at the top of the pile is removed by the toner collection coil [B].

To remove the toner and other particles that are accumulated at the edge of the cleaning blade, the drum turns in reverse for about 5 mm at the end of every copy job.

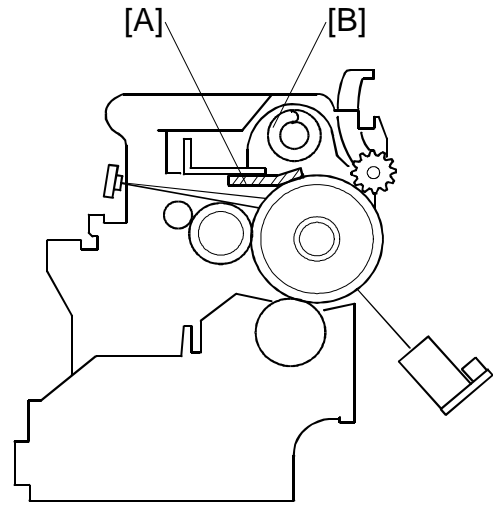

6.10.2 TONER RECYCLING

Toner picked up by the toner collection coil [A], is transported to the opening [B] in the side of the PCU. Then, this toner falls into the development unit with new toner coming from the toner bottle and it is all mixed together by mixing auger 1 [C] and used again.

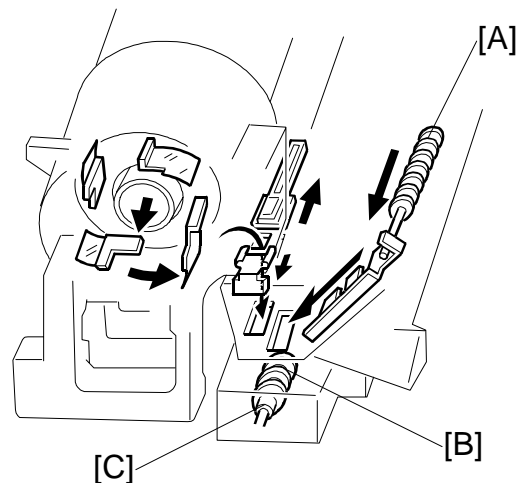
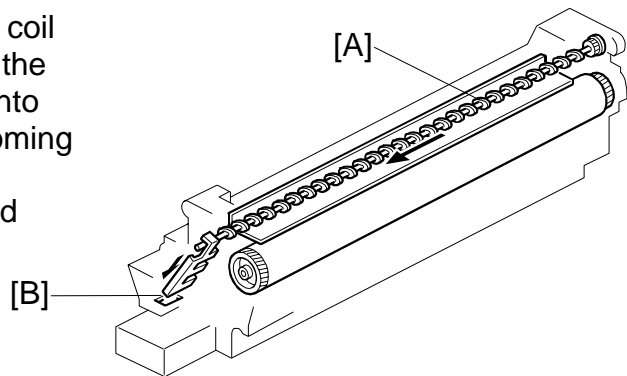

6.11 PAPER FEED

6.11.1 OVERVIEW

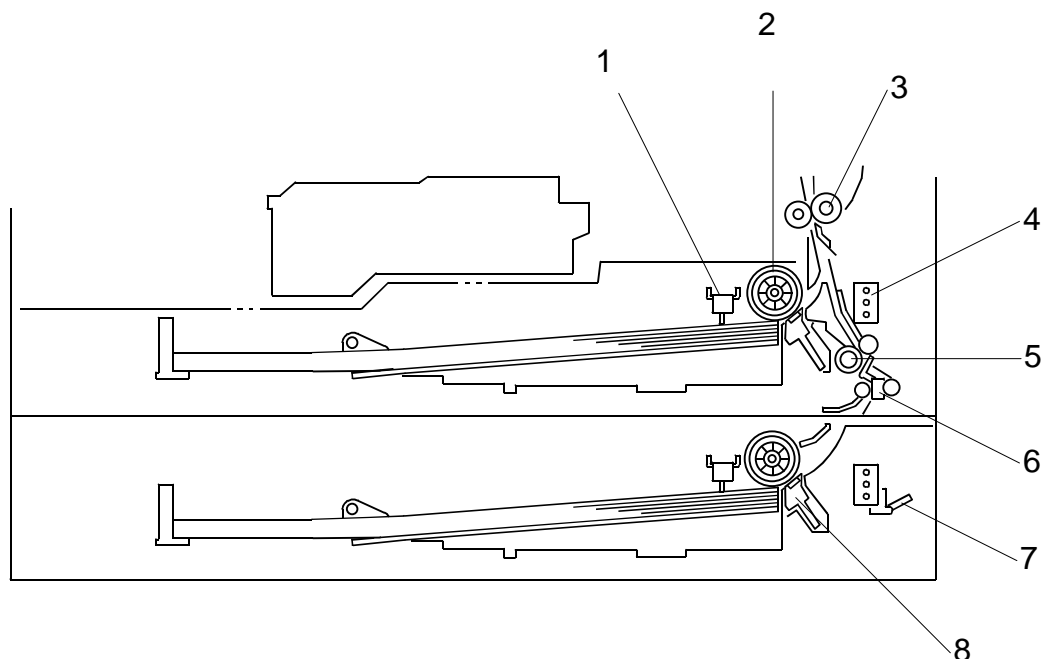

There are one or two paper trays, each of which can hold 250 sheets.

The paper tray feed stations use a friction pad system. To prevent paper from getting caught inside the machine when the tray is pulled out, the paper feed roller and shaft do not separate from the tray when the tray is pulled out.

The two relay sensors are used for paper jam detection. The lower one detects jams when paper is fed up from the optional paper feed unit.

The components of the paper feed station are as follows.

- | | |
|------------------------|-----------------------|
| 1. Paper End Sensor | 5. Upper Relay Roller |
| 2. Paper Feed Roller | 6. Upper Relay Sensor |
| 3. Registration Roller | 7. Lower Relay Sensor |
| 4. Paper Size Switch | 8. Friction Pad |

PAPER FEED

6.11.2 PAPER FEED DRIVE MECHANISM

The main motor [A] drives the pick-up and feed mechanism of both the first and second paper trays. The paper feed clutches [B] transfer drive from this motor to the paper feed rollers [C].

When the paper feed clutch turns on, the feed roller starts to feed the paper. The paper feed clutch stays on until shortly after the registration sensor has been activated.

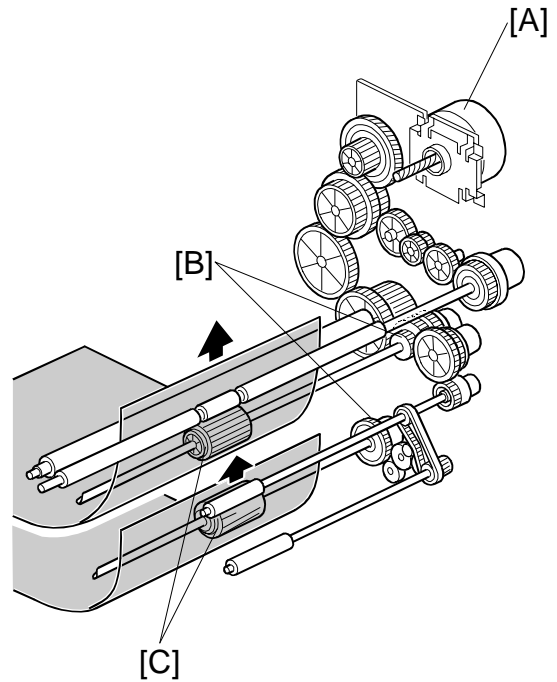

6.11.3 PAPER FEED AND SEPARATION MECHANISM

The paper feed roller [A] drives the top sheet of paper from the paper tray to the copier. The friction pad [B] allows only one sheet to feed at a time. The friction pad applies pressure to the feed roller with a spring [C].

The friction pad pressure cannot be adjusted.

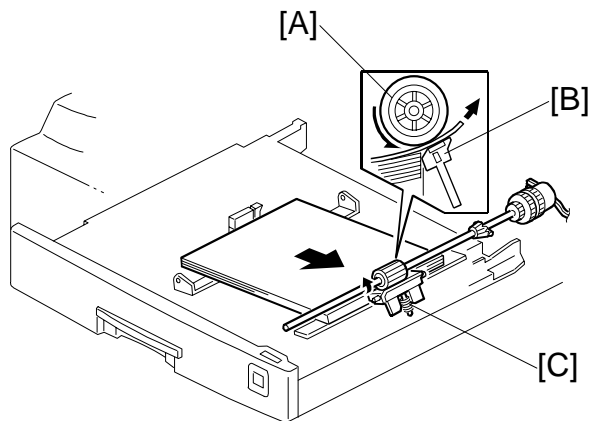

6.11.4 PAPER LIFT MECHANISM

When the paper tray [A] is closed, projection [B] on the copier frame pushes slider [C] (on the bottom part of the paper tray) off the bottom plate hook [D]. After the release slide comes off, compressed springs lift the bottom plate.

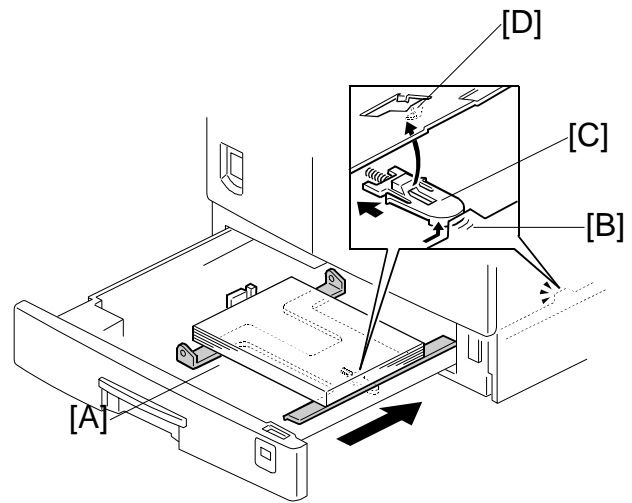

6.11.5 PAPER END DETECTION

If there is any paper in the paper tray, the paper stack lifts the feeler, the paper end sensor [A] is deactivated.

When the paper tray runs out of paper, the paper end feeler drops into the cutout [B] in the tray bottom plate and the paper end sensor is activated.

When the paper tray is drawn out with no paper in the tray, the shape of the paper end feeler causes it to lift up.

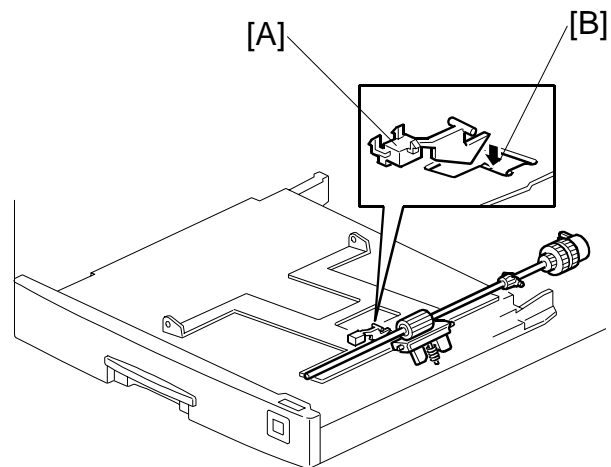

PAPER FEED

6.11.6 PAPER SIZE DETECTION

Paper Tray

Size \ SW	1	2	3
A3, 11" x 17"	○	○	○
A4 LEF	●	●	○
A4 SEF, 8 1/2" x 11"	●	○	○
A5 LEF, 8 1/2" x 14"	○	●	●
8 1/2" x 13"	●	○	●
11" x 8 1/2"	○	●	○
* (Asterisk)	○	○	●

●: ON (Not pushed)
○: OFF (Pushed)

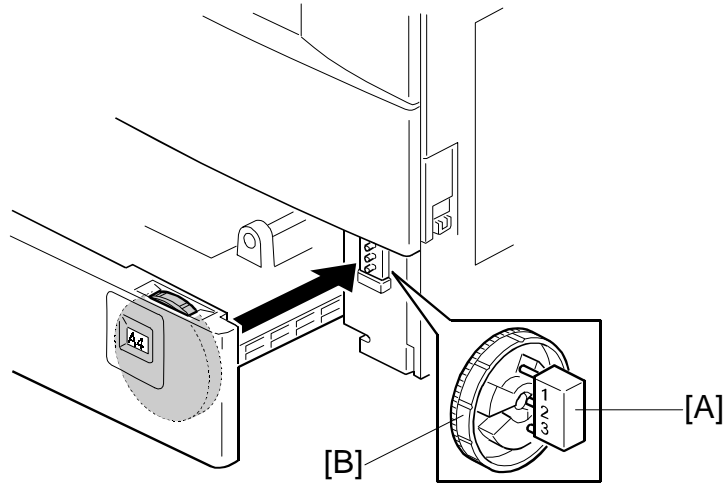

There are three paper size microswitches [A] on the front right plate of the paper tray unit. The switches are actuated by a paper size actuator [B] behind the paper size indicator plate, which is on the front right of the tray.

Each paper size has its own actuator, with a unique combination of notches. To determine which size has been installed, the CPU reads which microswitches the actuator has switched off.

The CPU disables paper feed from a tray if the paper size cannot be detected. If the paper size actuator is broken, or if there is no tray installed, the Add Paper indicator will light.

When the paper size actuator is at the "*" mark, the paper tray can be set up to accommodate one of a wider range of paper sizes by using User Tools. If the paper size for this position is changed without changing the User Tool setting, a paper jam will result.

By-pass Tray

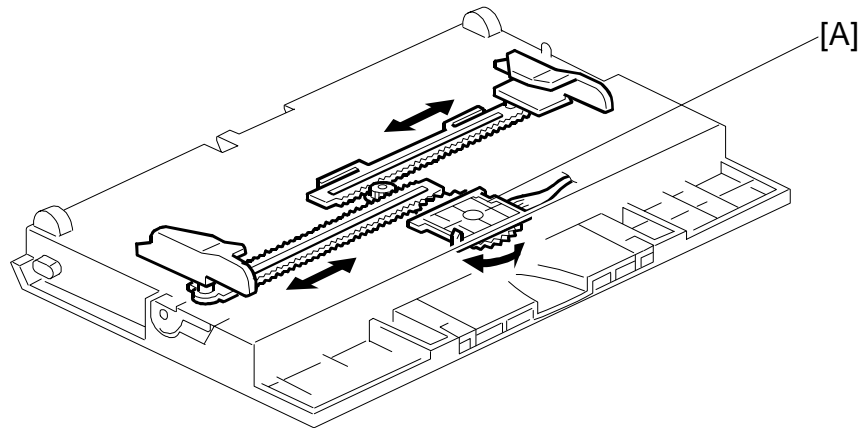

The by-pass feed paper width sensor [A] monitors the paper width. The side fence is connected to the terminal plate gear. When the side fences move to match the paper width, the circular terminal plate rotates over the wiring patterns on the rectangular part of the width sensor. The patterns for each paper width on the paper width detection sensor are unique.

North America

CN No. (IOB)	11" x 17"	8 1/2" x 11"	5 1/2" x 8 1/2"		
CN311-1	ON/OFF	OFF	OFF	OFF	OFF
CN311-2	OFF	OFF	OFF	ON	OFF
CN311-3 (GND)	OFF	OFF	OFF	OFF	OFF
CN311-4	OFF	ON	OFF	OFF	ON
CN311-5	ON	ON	OFF	OFF	OFF

Europe/Asia

CN No. (IOB)	A3	A4 SEF	8" x 13"	A5 SEF
CN311-1	ON/OFF	OFF	OFF	OFF
CN311-2	OFF	OFF	OFF	ON/OFF
CN311-3 (GND)	OFF	OFF	OFF	OFF
CN311-4	OFF	ON	ON	OFF
CN311-5	ON	ON	OFF	OFF

Detailed Descriptions

6.11.7 SIDE FENCES

If the tray is full of paper and it is pushed in strongly, the fences may deform or bend. This may cause the paper to skew or the side-to-side registration to be incorrect. To correct this, each side fence has a stopper [A] attached to it. Each side fence can be secured with a screw, for customers who do not want to change the paper size.

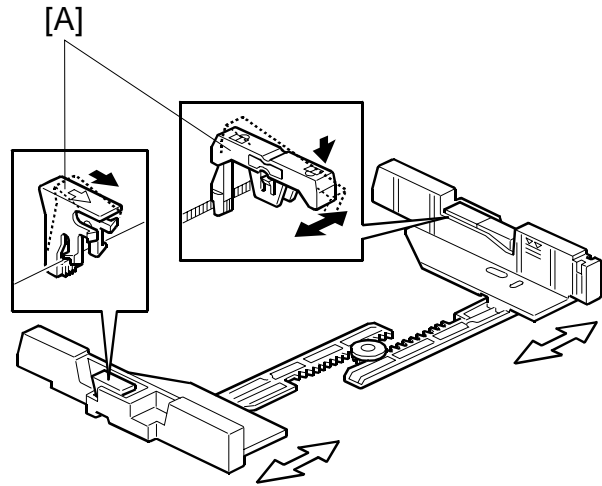

6.11.8 PAPER REGISTRATION

The drive from the main motor [A] is transmitted to the registration roller through the registration clutch gear [B].

The registration sensor [C] is used for correcting paper skew and for detecting paper misfeeds.

The cleaning mylar [D] contacts the registration roller. It removes paper dust from the registration roller so that this dust will not transfer into the development unit through the drum cleaning unit.

The amount of paper buckle at the registration roller to correct skew can be adjusted with SP1-003.

If jams frequently occur after registration, SP1-903 can be used to activate the relay clutch so that the relay roller assists the registration roller in feeding the paper along. When feeding from the by-pass tray, the by-pass feed clutch is activated, turning the by-pass feed roller. This feature may be needed when feeding thick paper, and cannot be used for the first paper feed tray.

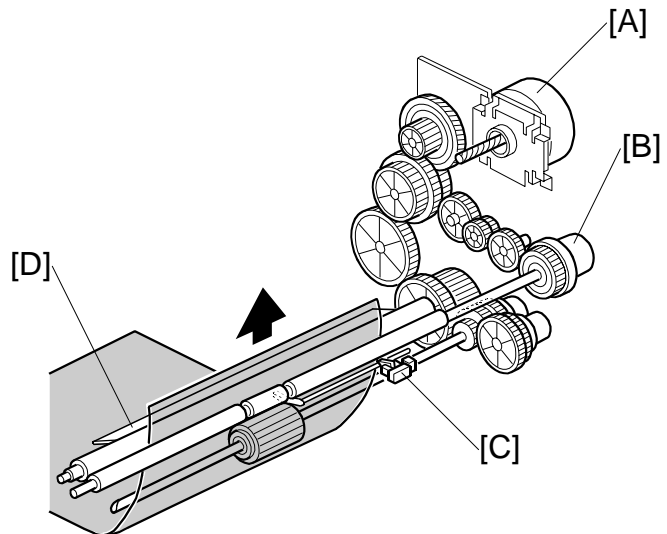

6.12 IMAGE TRANSFER AND PAPER SEPARATION

6.12.1 OVERVIEW

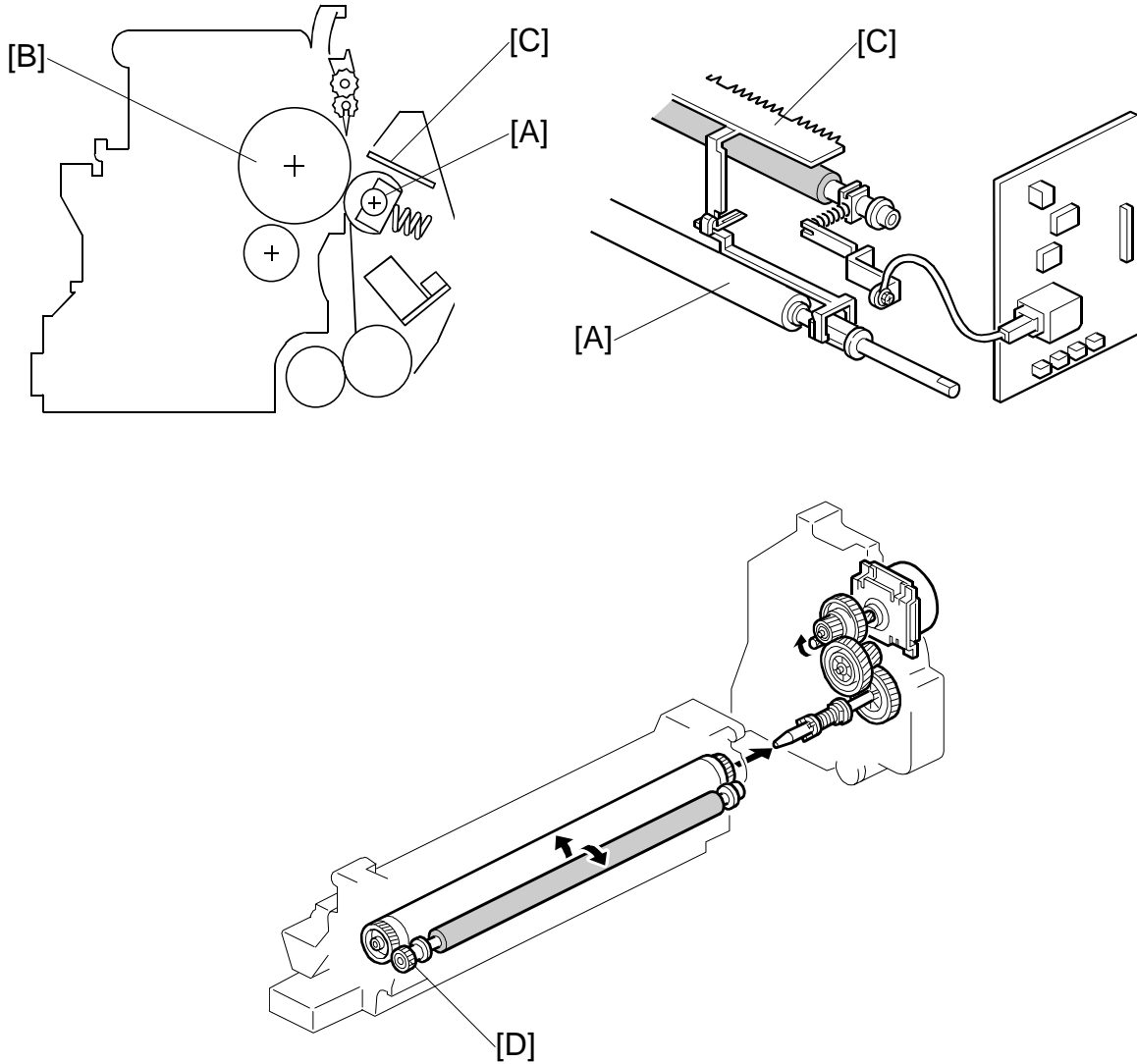

The transfer roller [A] touches the surface of the drum [B]. The high voltage supply board supplies a positive current to the transfer roller, which attracts the toner from the drum onto the paper. The current depends on the paper width, paper type, and paper feed tray.

The curvature of the drum and the discharge plate [C] help the paper to separate from the drum. The discharge plate is grounded.

Drive from the drum through a gear [D] turns the transfer roller.

6.12.2 IMAGE TRANSFER CURRENT TIMING

There are two transfer current levels: low and high. The image transfer procedure is as follows:

1. When the CPU receives the image writing start signal, the CPU instructs the high voltage supply board to supply +10 μ A (low transfer current level) to the roller. This prevents any positively charged toner on the drum surface from transferring to the transfer roller.
2. At a certain time after the low transfer current has been supplied to the roller, high transfer current is applied to the roller to transfer the toner to the paper (see the table below).
3. After the trailing edge of the paper has passed through the roller, transfer current turns off. In multiple copy mode, the transfer current shifts again to the low transfer current.

The high transfer current levels (default) are as shown in the following table. With SP2-301, the high transfer current level used for the paper feed trays, duplex tray, by-pass tray, and cleaning can be adjusted.

Paper Size	Paper Tray/ By-pass Tray (Normal)	By-pass Tray (Thick/OHP)	By-pass Tray (Special/ Envelope)	Duplex (2nd Side)
A3/A4 LEF	11 μ A	10 μ A	12 μ A	9 μ A
11" x 17"	16 μ A	11 μ A	13 μ A	11 μ A
B4/B5 LEF	11 μ A	11 μ A	13 μ A	16 μ A
8 1/2" x 11"	15 μ A	15 μ A	13 μ A	17 μ A
A4 SEF	13 μ A	19 μ A	25 μ A	19 μ A
B5 SEF	17 μ A	20 μ A	25 μ A	20 μ A
A5/A6/B6/5 1/2" x 8 1/2" SEF	17 μ A	20 μ A	25 μ A	25 μ A

Be careful when increasing the transfer current. This may cause a ghosting effect, in which part of the image at the top of the page is repeated lower down the page at a lower density. In the worst case, it may also damage the OPC drum.

6.1.3 TRANSFER ROLLER CLEANING

If the paper size is smaller than the image, or if a paper jam occurs during printing, toner may be transferred to the roller surface. To prevent the toner from transferring to the back side of the printouts, the transfer roller requires cleaning before the next printing run.

During transfer roller cleaning, the high voltage supply unit supplies a negative cleaning voltage (about -1 kV) to the transfer roller. Any negatively charged toner on the transfer roller is then transferred back to the drum. Then a positive cleaning current ($+10$ μ A) is applied to the transfer roller to push back to the drum any positively charged toner on the transfer roller.

The machine goes through the cleaning mode in the following conditions:

- Before starting the printing job (only if enabled with SP2-996; note that the default setting is off)
- Just after the power is switched on.
- After a copy jam has been cleared
- After 10 or more sheets of paper have been copied and the copy job has finished.

Also, the transfer roller cleaning current can be adjusted using SP2-301-4.

6.1.4 PAPER SEPARATION MECHANISM

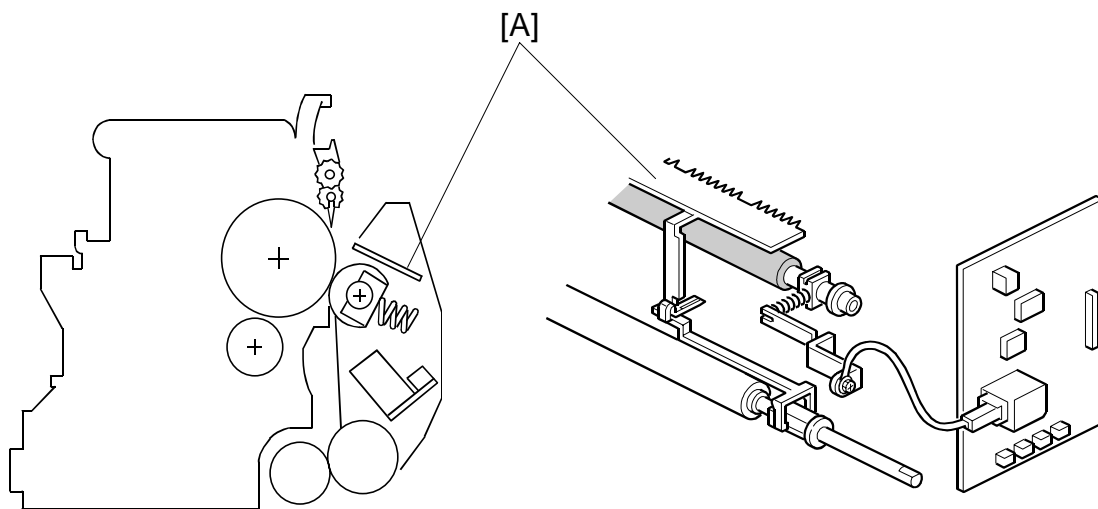

The discharge plate [A] and the drum curvature of the drum help the paper to separate away from the drum. The discharge plate is grounded.

6.13 IMAGE FUSING AND PAPER EXIT

6.13.1 OVERVIEW

The fusing unit and paper exit area consist of the following parts.

1. Paper exit roller
2. Fusing exit sensor
3. Hot roller strippers
4. Pressure roller
5. Pressure spring
6. Fusing lamp
7. Thermistor
8. Hot roller
9. Thermofuse
10. Thermostat

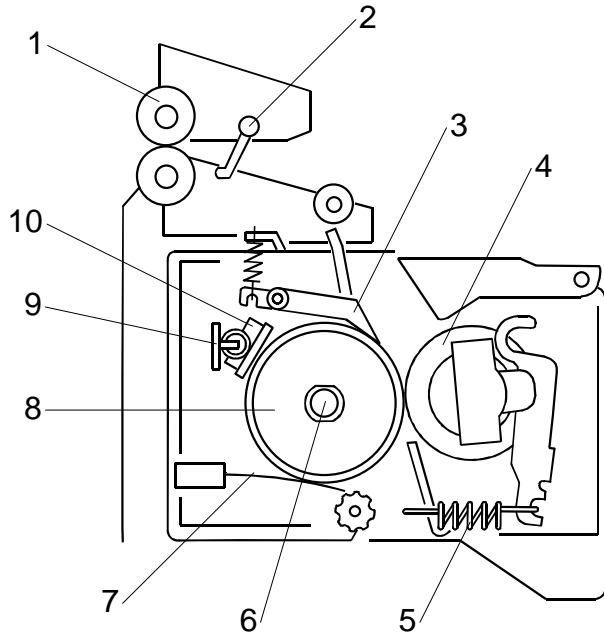

6.13.2 FUSING DRIVE AND RELEASE MECHANISM

The main motor [A] drives the fusing unit through a gear train and drives the paper exit rollers [B] through a timing belt [C].

The fusing unit release mechanism automatically disengages the fusing unit drive gear [D] when the right cover [E] is opened. This allows the fusing unit drive gear to rotate freely so that misfed paper can easily be removed.

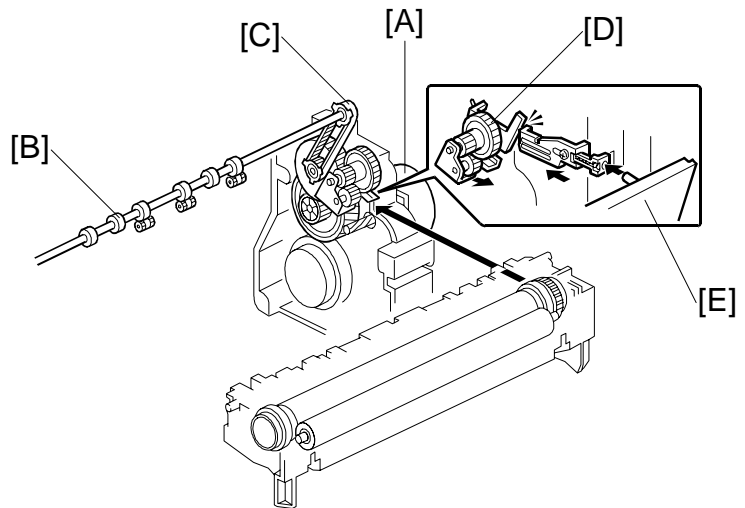

6.13.3 FUSING ENTRANCE GUIDE SHIFT

The entrance guide [A] is adjustable for paper thickness to prevent creasing. The outer screw holes [B] on each side are used as the default setting.

If creasing occurs frequently in the fusing unit, adjust the entrance guide to the right, by securing it with the inner holes [C]. This allows more direct access to the gap between the hot roller and the pressure roller.

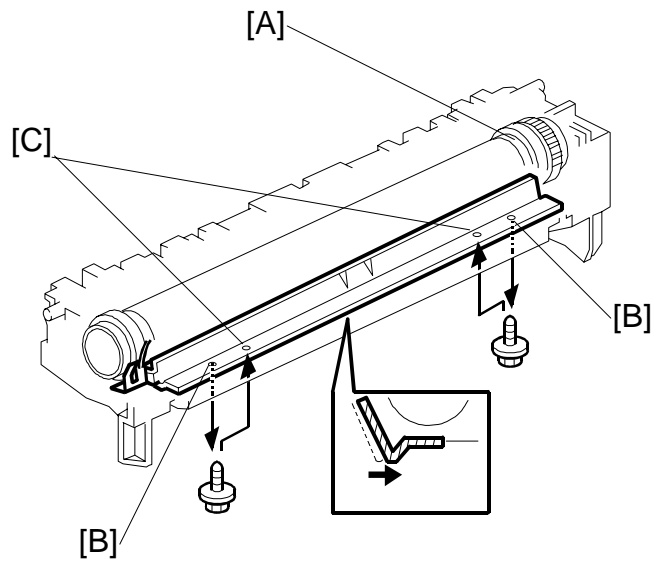

6.13.4 PRESSURE ROLLER

The pressure springs [A] constantly apply pressure between the hot roller [B] and the pressure roller [C].

Applied pressure can be changed by adjusting the position of the pressure springs. The spring is positioned at the end [D] as the default setting.

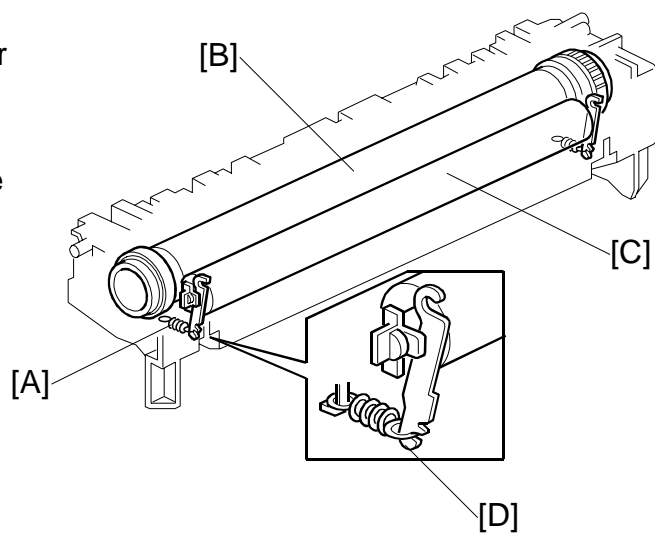

Detailed Descriptions

6.13.5 FUSING TEMPERATURE CONTROL

Overview

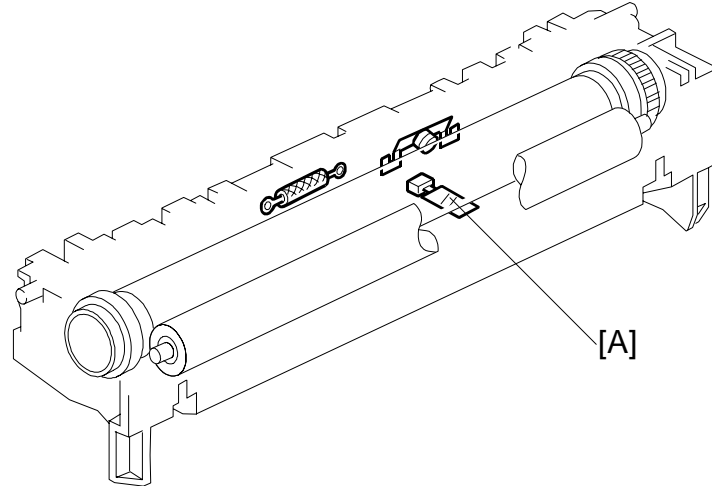

The fusing temperature is controlled using the fusing thermistor [A].

The CPU checks the output from the fusing thermistor once a second. The CPU compares the current and previous temperature, then decides the power-on ratio for the next second. To maintain the target temperature, the CPU controls the fusing lamp power-on ratio as shown in the following table (the temperature control algorithm only works with whole numbers).

The fusing lamp works to maintain a target fusing temperature of 175°C during copying.

Initializing

Sampling cycle: 1 second
 Soft start setting: 3 cycles

Previous minus Current	Current minus Target				
	-3°C or less	-2°C or -1°C	0°C	+1°C or +2°C	+3°C or more
-3°C or less	100%	50%	0%	0%	0%
From -2°C to -1°C	100%	50%	0%	0%	0%
0°C	100%	50%	0%	0%	0%
From +1°C to +2°C	100%	50%	0%	0%	0%
+3°C or more	100%	50%	0%	0%	0%

Ratio (%): The proportion of time that the fusing lamp power is on

Copying (North America Model)

Sampling cycle: 1 second
Soft start setting: 3 cycles

Previous minus Current	Current minus Target				
	-3°C or less	-2°C or -1°C	0°C	+1°C or +2°C	+3°C or more
-3°C or less	100%	100%	100%	100%	0%
From -2°C to -1°C	100%	70%	70%	70%	0%
0°C	100%	50%	30%	30%	0%
From +1°C to +2°C	100%	30%	0%	0%	0%
+3°C or more	100%	0%	0%	0%	0%

Ratio (%): The proportion of time that the fusing lamp power is on

Copying (Europe Model)

Sampling cycle: 1 second
Soft start setting: 10 cycles

Previous minus Current	Current minus Target				
	-3°C or less	-2°C or -1°C	0°C	+1°C or +2°C	+3°C or more
-3°C or less	100%	100%	100%	0%	0%
From -2°C to -1°C	100%	100%	100%	0%	0%
0°C	100%	100%	100%	0%	0%
From +1°C to +2°C	100%	100%	100%	100%	0%
+3°C or more	100%	100%	100%	100%	0%

Ratio (%): The proportion of time that the fusing lamp power is on

Standby

Sampling cycle: 1 second
Soft start setting: 3 cycles (Europe model: 20 cycles)

Previous minus Current	Current minus Target				
	-3°C or less	-2°C or -1°C	0°C	+1°C or +2°C	+3°C or more
-3°C or less	100%	100%	0%	0%	0%
From -2°C to -1°C	100%	100%	0%	0%	0%
0°C	100%	100%	0%	0%	0%
From +1°C to +2°C	100%	100%	100%	0%	0%
+3°C or more	100%	100%	100%	0%	0%

Ratio (%): The proportion of time that the fusing lamp power is on

Detailed Descriptions

Fusing Lamp Control

Turning on and off the fusing lamp power causes fluorescent light in the room to flicker. To reduce the flickering, use the following SP modes.

Fusing temperature detection cycle (SP1-108)

The CPU checks the output from the fusing thermistor once a second (default setting). The CPU compares the current and previous temperatures. Based on the result, it then decides how long the fusing lamp power should be on during the next one-second interval (also, if the current temperature is too high, the power will not be needed).

Starting and stopping the fusing lamp power every second causes fluorescent lighting in the room to flicker. To reduce this flickering, use SP1-108 to change the cycle from 1 second to 3 seconds.

Fusing soft-start (SP1-107)

In addition, whenever the fusing lamp power switches on, full power is applied to the fusing lamp gradually, not all at once. This prevents the power in the room from dropping suddenly. This feature is known as “Soft Start”. The machine does this by gradually allowing more power to the fusing lamp over a number of zero-cross cycles of the ac supply. The diagram below shows full power being applied gradually over the duration of 3 zero-cross cycles. With SP1-107, this number can be set to 3, 10, or 20. Soft start occurs every time the fusing lamp power switches on (i.e., at some time during every second), not just at the start of the print job.

NOTE: This SP mode is effective to counter flickering lights. However, generated noise increases if the setting is changed from the default. If a radio or a TV is close by the machine, the noise may have some effect on the image or sound.

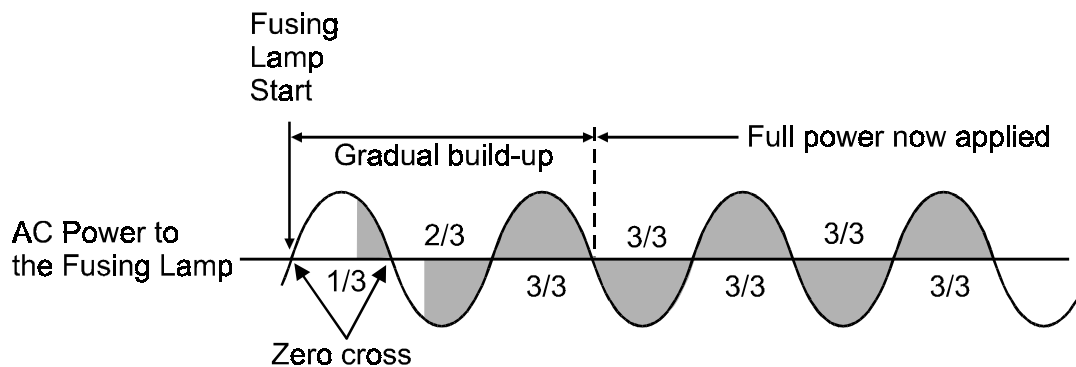

Fusing Temperature Control for Thick Paper at the By-pass Tray

When thick paper mode is selected, the machine changes the target fusing temperature from 175°C to 185°C. When the by-pass tray is selected, the machine detects that the paper is thick. This setting can be changed with SP5-952.

Pre-heat Mode (Fusing Idling)

When the machine is powered on, or the front or right door is closed, the hot roller turns for 6 seconds.

If the SP1-103 setting is 1 (Yes), when the fusing thermistor detects a temperature lower than 100°C, the hot roller turns for 30 seconds (instead of for just 10 s) after the machine is powered on, or the right door is closed. This maintains conditions for fusing copies made on thick paper during cold weather conditions.

To Prevent Offset when Making Multiple Copies on Small-width Paper

This prevents the temperature at the ends of the hot roller from being higher than at the center.

If the smallest copy paper width detected during a 40 seconds interval is less than 220 mm, the machine lowers the target fusing temperature by 10°C.

Then, during the next 80 seconds, if the smallest width detected is less than 220 mm again, the machine lowers the target temperature by another 5°C.

Reduced Copy Speed with Narrow Paper

To ensure that images are properly fused onto paper 220 mm or less in width, the machine automatically reduces the copy speed under the following conditions:

- After 180 seconds of continuous copying
- When Thick or Special paper mode is used
- Paper is fed from the by-pass tray

Paper Size	Copy Speed Until 180 s	Copy Speed From 180 s
8 1/2" x 11" SEF (216 x 279)	14	9.3
8 1/2" x 13" (216 x 356)	12	8.4
A4 SEF (210 x 297)	14	9.3
A5 LEF (210 x 148)	20.5	11.9
B5 SEF (182 x 257)	16	10.2
A5 SEF (148 x 210)	18	11
5 1/2" x 8 1/2" SEF (140 x 216)	18	11
A6 SEF (105 x 148)	18	11

Copy speed is measured in copies/minute.

6.1.6 OVERHEAT PROTECTION

If the hot roller temperature becomes greater than 230°C for more than 1 second, the CPU cuts off the power to the fusing lamp. At this time, the LCD will display SC543.

Even if the thermistor overheat protection fails, there is a thermostat in series with the common ground line of the fusing lamp. If the temperature of the thermostat reaches 180°C, the thermostat opens, cutting the power to the fusing lamp, and printing stops. At the same time, SC544 or 546 is generated. After resetting the SC, when turning on the main switch, SC541 will appear.

There is also a thermofuse to ensure overheat protection. If the temperature of the thermofuse reaches 172°C, the thermofuse opens, cutting the power to the fusing lamp. The thermofuse is farther from the hot roller than the thermostat, so it opens later than the thermostat.

6.14 DUPLEX UNIT

6.14.1 OVERALL

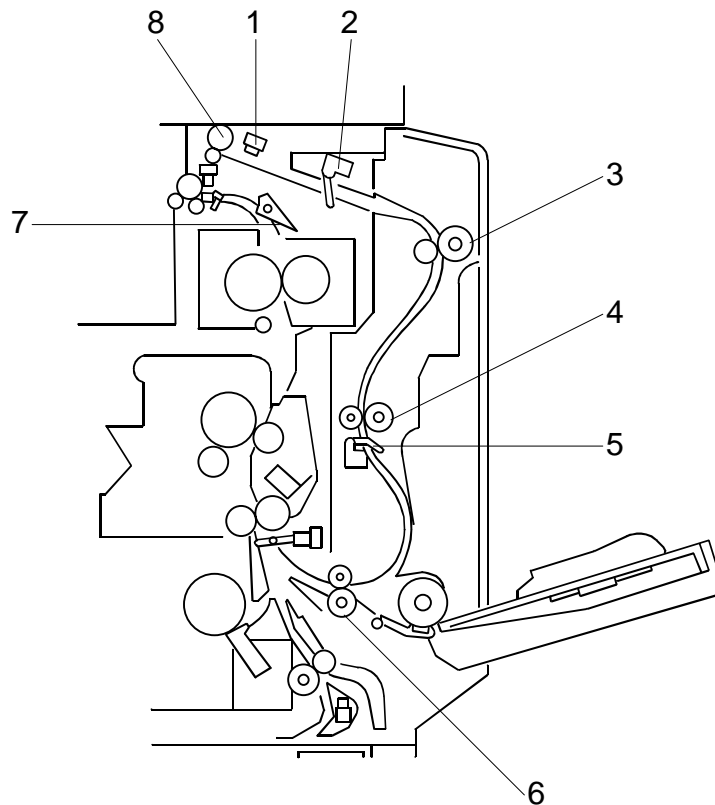

The printed page from the fusing unit goes straight through to the exit tray, or upward to the inverter section, depending on the position of the junction gate.

If the user selects duplex mode, the page is directed to the inverter tray, then reversed through the duplex unit, and back into the machine for printing the second side.

- | | |
|----------------------------|---------------------------|
| 1. Duplex Inverter Sensor | 5. Exit Sensor |
| 2. Duplex Entrance Sensor | 6. Lower Transport Roller |
| 3. Upper Transport Roller | 7. Junction Gate |
| 4. Middle Transport Roller | 8. Duplex Inverter Roller |

DUPLEX UNIT

6.14.2 DRIVE MECHANISM

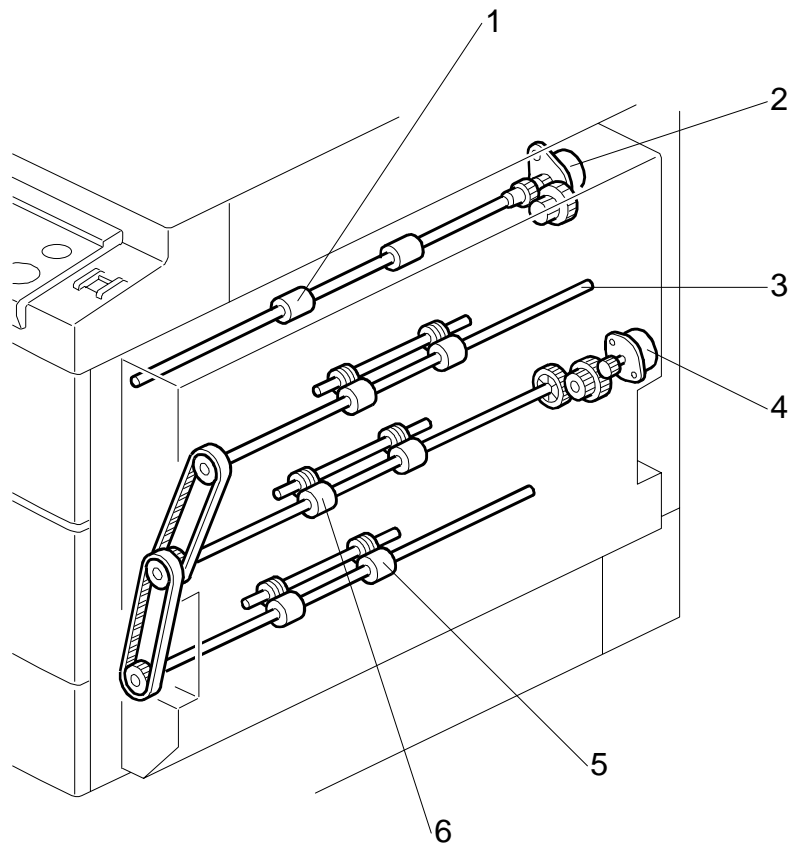

1. Duplex Inverter Roller
2. Duplex Inverter Motor
3. Upper Transport Roller

4. Duplex Transport Motor
5. Lower Transport Roller
6. Middle Transport Roller

6.14.3 BASIC OPERATION

To increase the productivity of the duplex unit, copies are printed as follows.

Larger than A4 Short-edge/LT Short-edge

The paper feed path can hold only one sheet of copy paper at a time.

Example: 8 pages. The number [A] in the illustration shows the order of pages. The number [B] in the illustration shows the order of sheets of copy paper (if black, this indicates the second side).

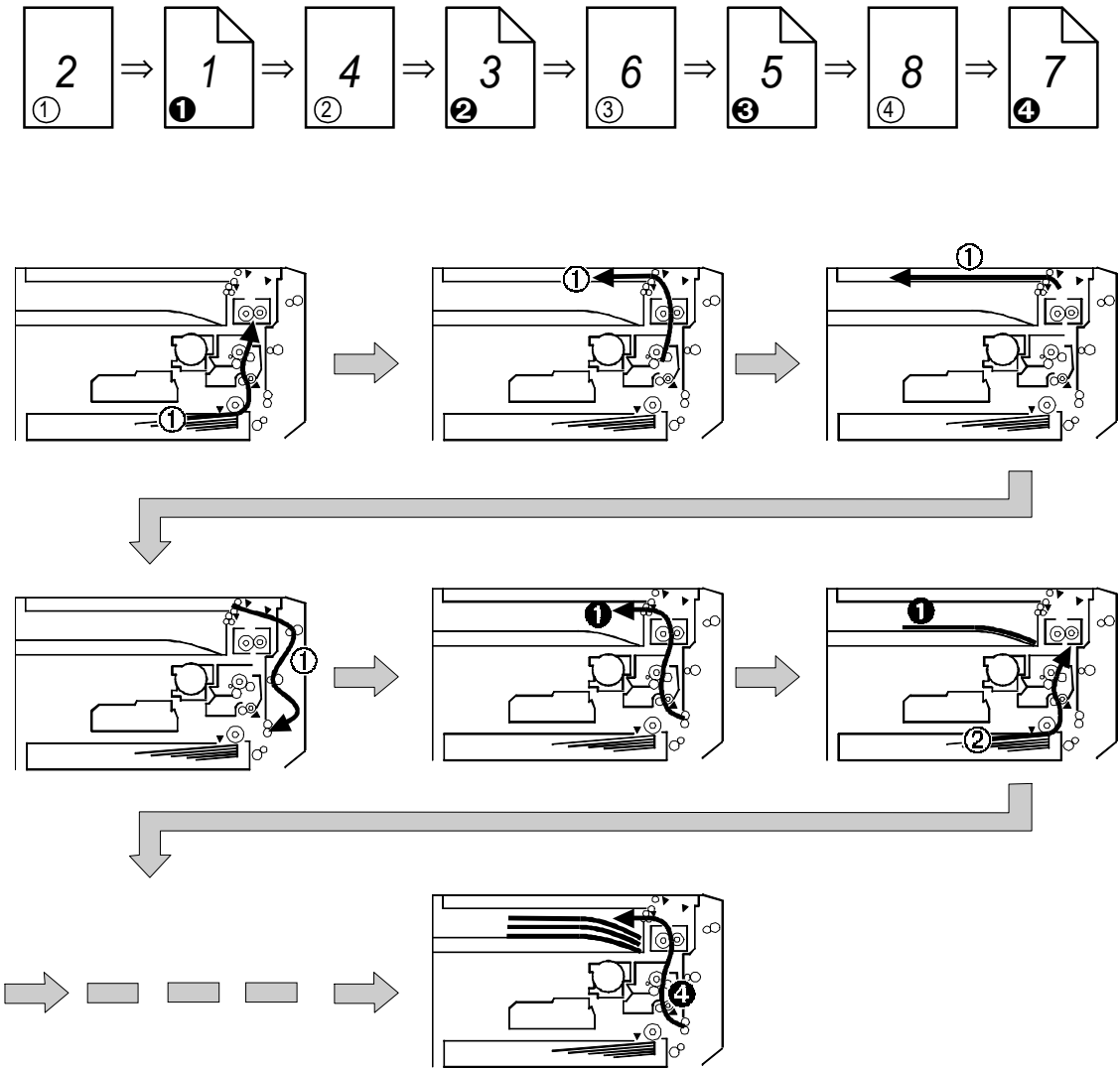

Detailed Descriptions

DUPLEX UNIT

Up to A4 Short-edge/LT Short-edge

The paper feed path can hold two sheets of copy paper.

Example: 8 pages. The number [A] in the illustration shows the order of pages. The number [B] in the illustration shows the order of sheets of copy paper (if black, this indicates the second side).

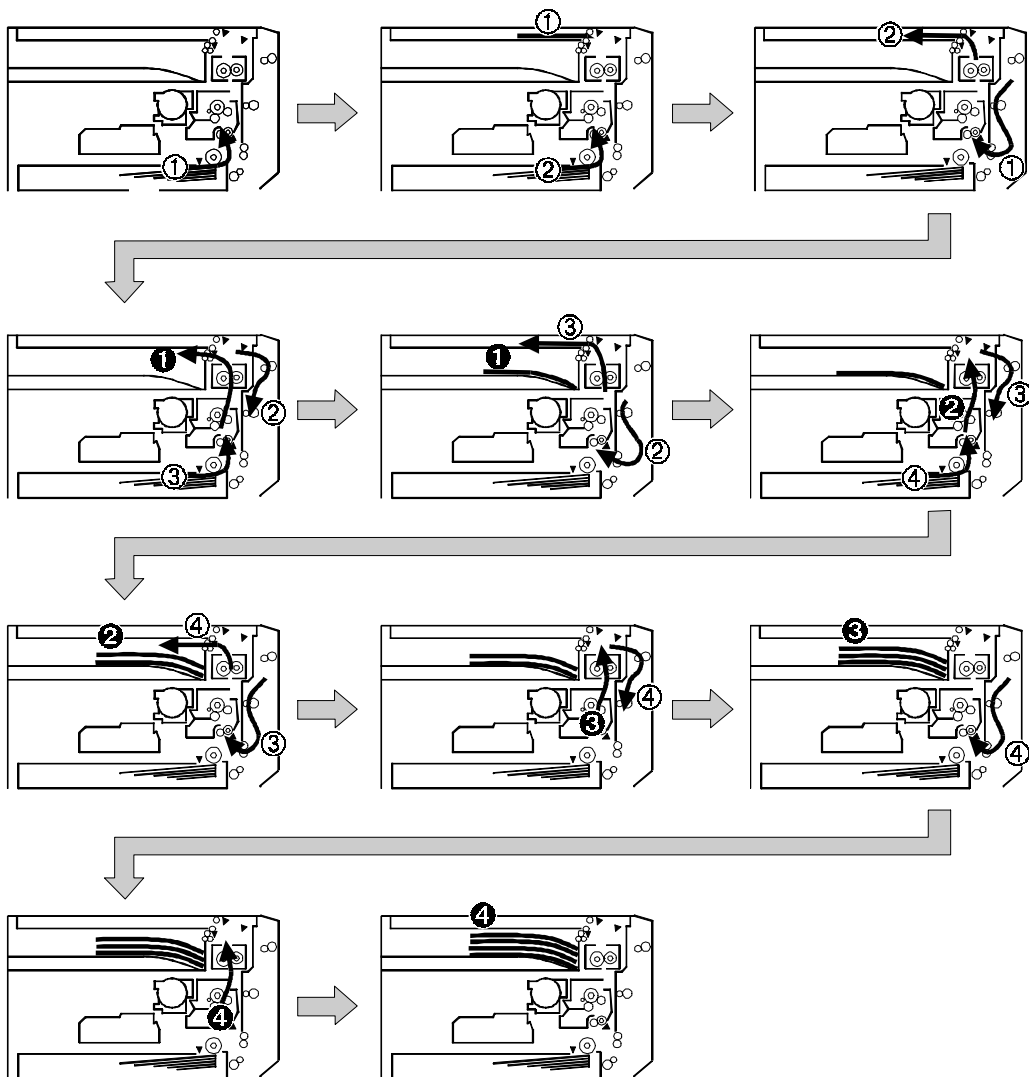
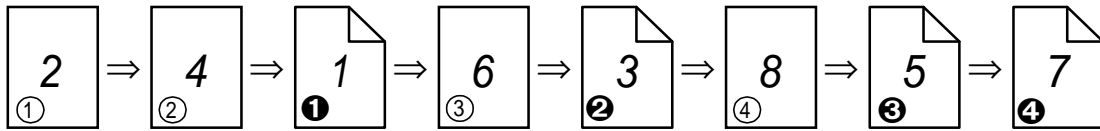

6.14.4 FEED IN AND EXIT MECHANISM

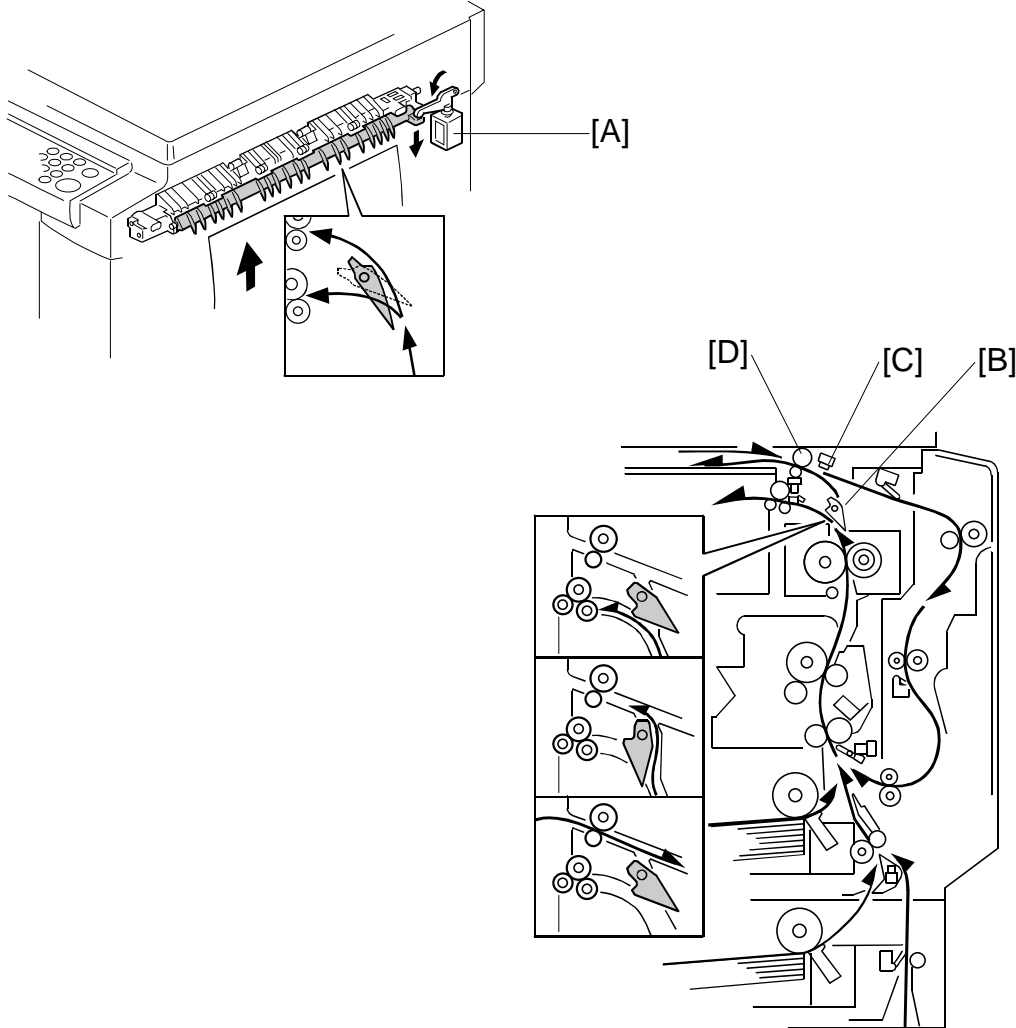

During duplex copying, the inverter gate solenoid [A] switches on and the junction gate [B] switches over to direct the paper to the inverter. When the paper reaches the duplex inverter sensor [C], the inverter roller [D] reverses its rotation direction and the paper goes to the duplex unit. The paper is then sent to the mainframe registration rollers to print the reverse side.

If there are two or more copies being made with A4/8 1/2" x 11" SEF (or smaller), the next sheet waits at the registration sensor for the current sheet to exit the inverter.

Detailed Descriptions

6.15 ENERGY SAVER MODES

6.15.1 OVERVIEW

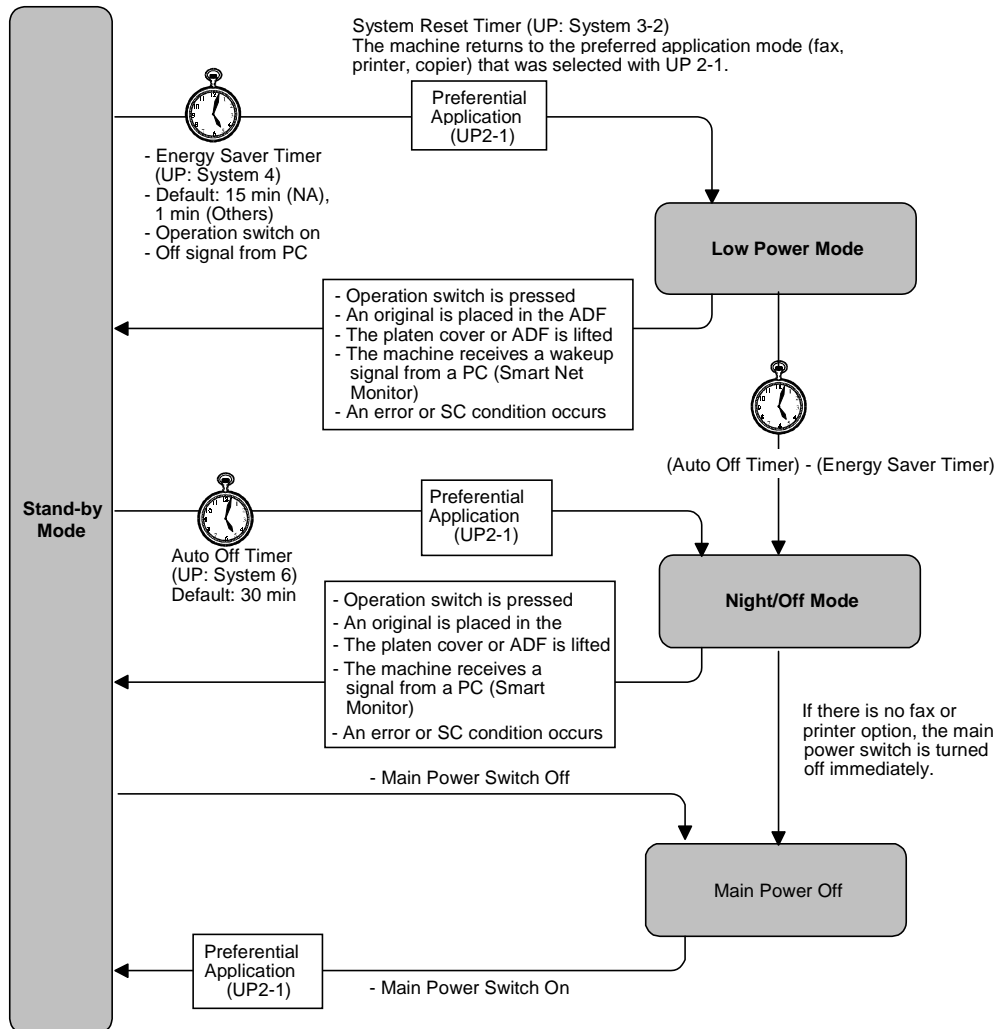

When the machine is not used, the energy saver function reduces power consumption by lowering the fusing temperature.

This machine has two types of energy saver modes:

- 1) Low power mode
- 2) Night/off mode

These modes are controlled by the following User Tools.

- Energy saver timer (Low power timer)
- Auto off timer
- Energy saver level
- Auto off disabling

The way that the machine operates depends on the combination of equipment installed (i.e. copier only, fax and/or printer installed).

6.15.2 LOW POWER MODE

Entering Low Power Mode

The machine enters low power mode when:

- The energy saver timer has expired following the last time engine components or sensors were active (e.g. end of a copy job, platen cover lifted, key pressed, etc).

User Tools - System Settings - Energy Saver Timer

The default setting is 15 min (NA), 1 min (Other)

If the energy saver timer setting is longer than the auto off timer setting, the machine will not enter low power mode. It will enter auto off mode instead, when the auto off timer runs out after the end of the job.

What Happens in Low Power Mode

There are three low power modes: Low power mode level 1, 2, and 3. The user can select the level with a User Tool (System Settings—Energy Saver Level).

Mode	Operation Switch	Fusing Temp.	Approx. Recovery Time	System +5V
Low Power Mode Level 1	Off	105 °C	10 s (NA) 12 s (Other)	On
Low Power Mode Level 2	Off	60 °C	15 s (NA) 18 s (Other)	On
Low Power Mode Level 3	Same as Night/Off mode			

NOTE: Low power mode Level 3 is the same as night/off mode (☛ 6.15.3 Night/Off Mode), except that when there are no fax or printer options installed, the main power switch is never turned off in low power mode.

When the machine enters low power mode, the fusing lamp drops to a certain temperature and the operation panel indicators are turned off except for the main power LED.

If the CPU receives the image print out command from an application (e.g. to print incoming fax data or to print data from a PC), the fusing temperature rises to print the data. However, the operation panel indicators stay off.

The fusing temperature for level 2 low power mode can be changed by SP1-105 (default setting is 60°C).

ENERGY SAVER MODES

Returning to Stand-by Mode

If one of the following is done, the machine returns to standby mode:

- Operation switch is pressed
- An original is placed in the ADF
- The platen cover or ADF is lifted
- The machine receives the wake-up signal from a PC (Smart Net Monitor)
- An error or SC condition occurs

6.15.3 NIGHT/OFF MODE

This is used instead of auto off mode when an optional fax and/or printer unit is installed.

If the customer selects the Low Power Mode Level 3 with UP mode (User Tools - System Settings - Energy Saver Level), this is the same condition as night/off mode, except that the main power switch does not turn off in low power mode.

Entering Night/Off Mode

The machine enters night/off mode when:

- The auto off timer has expired following the last time engine components or sensors were active (e.g. end of a copy job, platen cover lifted, key pressed, etc).

User Tools—System Settings—Auto Off Timer

The default setting is 30 min

If the energy saver timer setting is greater than the auto off timer setting, the machine will enter night/off mode (rather than low power mode) when the auto off timer runs out after the end of the job.

What Happens in Night/Off Mode

When the machine enters night/off mode, the fusing lamp and the operation panel indicators are turned off except for the main power LED.

If there is no fax or printer option, the main power switch is turned off immediately (this is Auto Off Mode).

Returning to Stand-by Mode

The machine returns to stand-by mode in the same way as from the low power mode.

The recovery time is about 20 s (NA) or 25 s (Other).

Mode	Operation Switch	Fusing Temp.	Approx. Recovery Time	System +5V
Night/Off mode	Off	Room Temp. (Fusing lamp off)	20 s (N. America) 25 s (other)	On

**AUTO REVERSE DOCUMENT FEEDER
B379**

1. OVERALL MACHINE INFORMATION

1.1 MECHANICAL COMPONENT LAYOUT

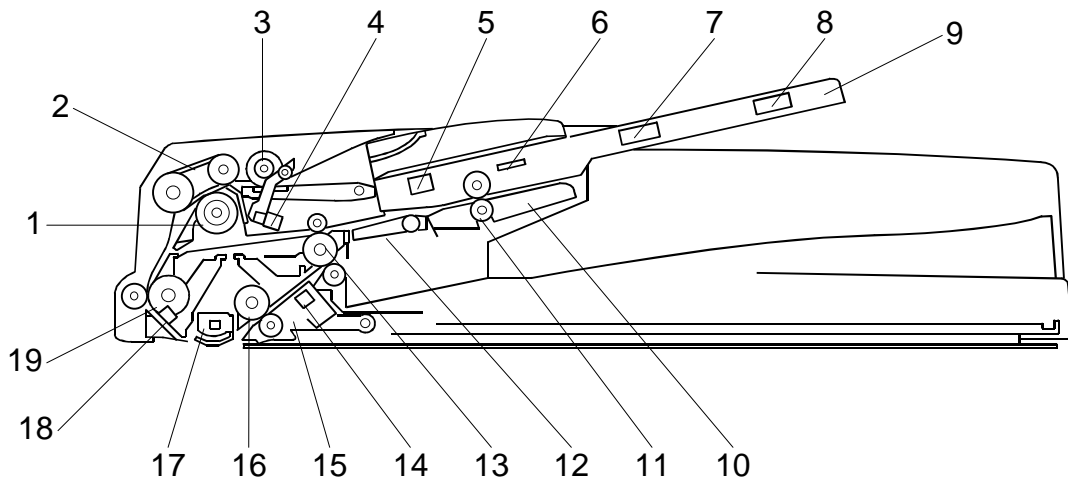

- | | |
|----------------------------------|-----------------------------|
| 1. Separation Roller | 11. Reverse Roller |
| 2. Paper Feed Belt | 12. Junction Gate |
| 3. Pick-up Roller | 13. Exit Roller |
| 4. Original Set Sensor | 14. Original Exit Sensor |
| 5. Original Trailing Edge Sensor | 15. Stamp |
| 6. Original Width Sensor Board | 16. 2nd Transport Roller |
| 7. Original Length Sensor 1 | 17. Original Exposure Guide |
| 8. Original Length Sensor 2 | 18. Registration Sensor |
| 9. Original Table | 19. 1st Transport Roller |
| 10. Reverse Table | |

1.2 ELECTRICAL COMPONENT LAYOUT

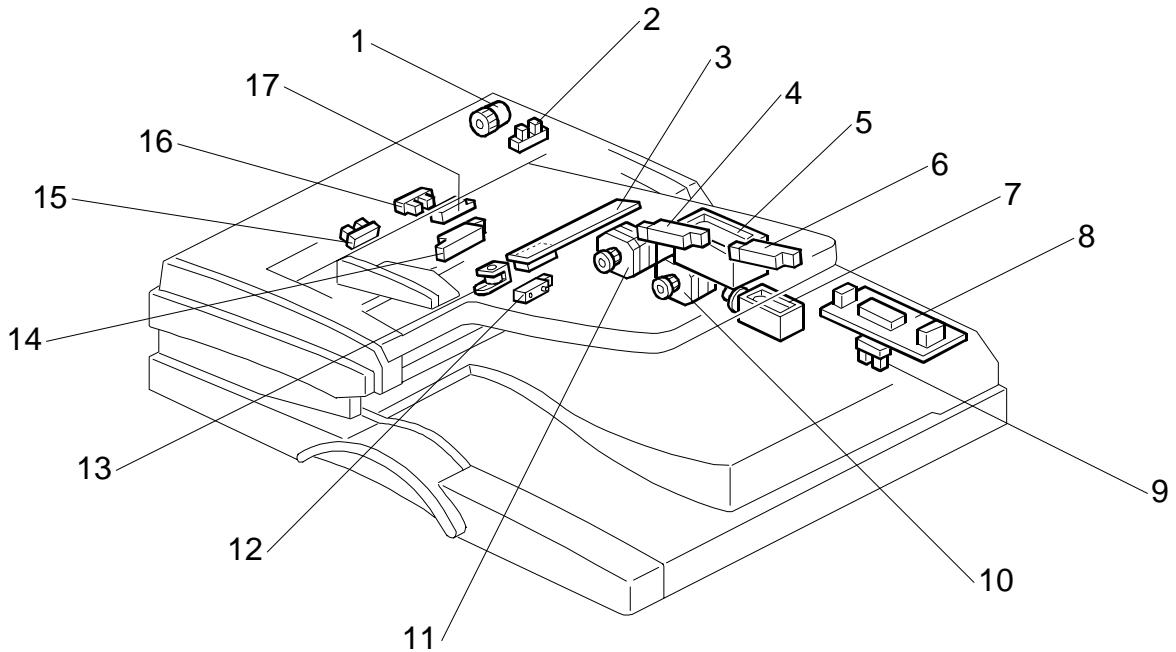

- | | |
|--------------------------------|-----------------------------------|
| 1. DF Feed Clutch | 10. DF Feed Motor |
| 2. Feed Cover Sensor | 11. DF Transport Motor |
| 3. Original Width Sensor Board | 12. Original Exit Sensor |
| 4. Original Length Sensor 1 | 13. Stamp Solenoid |
| 5. DF Pick-up Solenoid | 14. Original Trailing Edge Sensor |
| 6. Original Length Sensor 2 | 15. Original Set Sensor |
| 7. Junction Gate Solenoid | 16. Original Reverse Sensor |
| 8. DF Drive PCB | 17. Registration Sensor |
| 9. DF Position Sensor | |

1.3 DRIVE LAYOUT

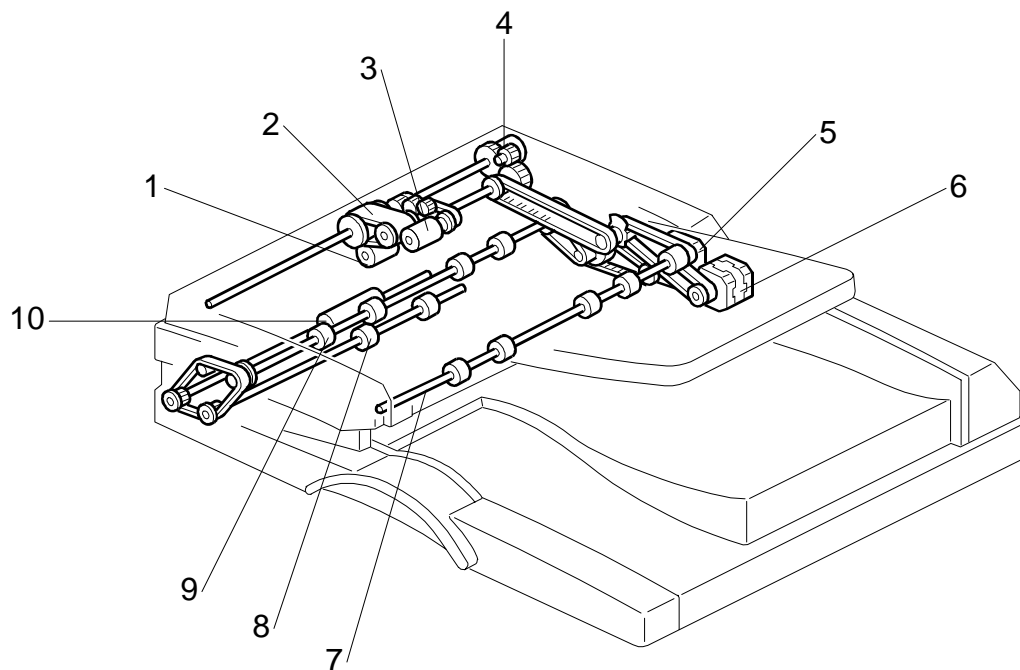

- | | |
|-----------------------|--------------------------|
| 1. Separation Roller | 6. DF Feed Motor |
| 2. Original Feed Belt | 7. Reverse Table Roller |
| 3. Pick-up Roller | 8. 2nd Transport Roller |
| 4. DF Feed Clutch | 9. Exit Roller |
| 5. DF Transport Motor | 10. 1st Transport Roller |

2. DETAILED SECTION DESCRIPTIONS

2.1 ORIGINAL SIZE DETECTION

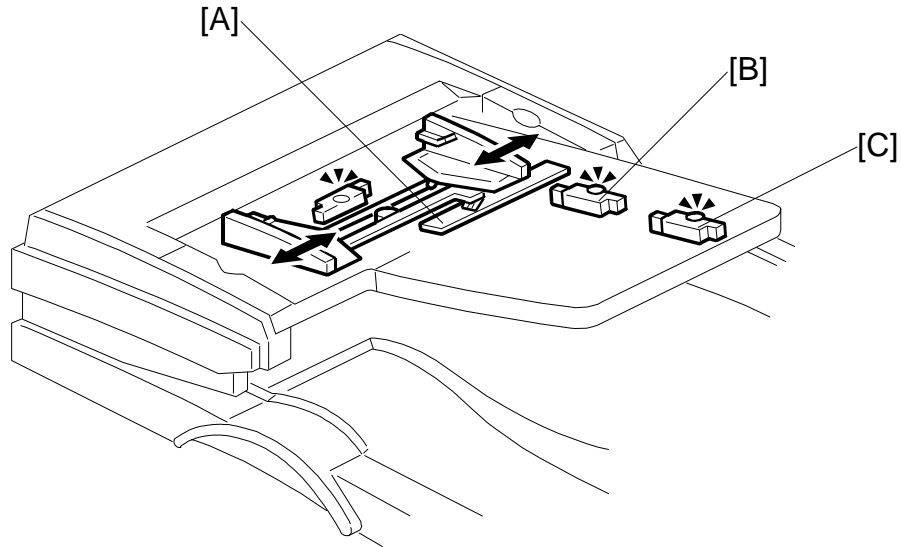

The original size detection mechanism consists of the original width sensor board [A] and two original length sensors-1 [B] and -2 [C]. Based on the combined output of the length sensors and the width sensor board, the machine can detect the size of the original. This integrated detection mechanism is detailed in the table on the next page.

Note that the width sensor's terminal plate is attached to the original guide, so the widths of the originals must all be the same.

		NA	EU	Original Length 1	Original Length 2	P1	P2	P3	P4
1	A3 (297 x 420)	X	○	ON	ON	-	-	-	ON
2	B4 (257 x 364)	X	○	ON	ON	-	-	ON	-
3	A4 SEF (210 x 297)	X	○	ON	-	-	ON	-	-
4	A4 LEF (297 x 210)	X	○	-	-	-	-	-	ON
5	B5 SEF (182 x 257)	X	○	ON	-	ON	-	-	-
6	B5 LEF (257 x 182)	X	○	-	-	-	-	ON	-
7	A5 SEF (148 x 210)	X	○	-	-	ON	-	-	-
8	A5 LEF (210 x 148)	X	○	-	-	-	ON	-	-
9	11" x 17"	○ ₁	X	ON	ON	-	-	-	ON
10	11" x 15"	● ₁	X	ON	ON	-	-	-	ON
11	10" x 14"	○	X	ON	ON	-	-	ON	-
12	8 1/2" x 14"	○ ₂	X	ON	ON	-	ON	-	-
13	8 1/2" x 13"	X	○ ₄	ON	ON	-	ON	-	-
14	8" x 13"	● ₂	● ₄	ON	ON	-	ON	-	-
15	8 1/2" x 11" SEF	○ ₃	X	ON	-	-	ON	-	-
16	11" x 8 1/2" LEF	○	X	-	-	-	-	-	ON
17	8" x 10" SEF	● ₃	X	ON	-	-	ON	-	-
18	5 1/2" x 8 1/2" SEF	○	X	-	-	ON	-	-	-
19	8 1/2" x 5 1/2" LEF	○	X	-	-	-	ON	-	-

NA: America (North, Middle, South) EU: Europe, Asia, China, Taiwan

X: No ○: Yes ON: Paper present

○₁, ●₁: In NA, original size 11" x 15" is detected as 11" x 17"

○₂, ●₂: In NA, original size 8" x 13" is detected as 8 1/2" x 14"

○₃, ●₃: In NA, original size 8" x 10" is detected as 8 1/2" x 11"

○₄, ●₄: In EU, original size 8" x 13" is detected as 8 1/2" x 13"

Original Width Sensor Board

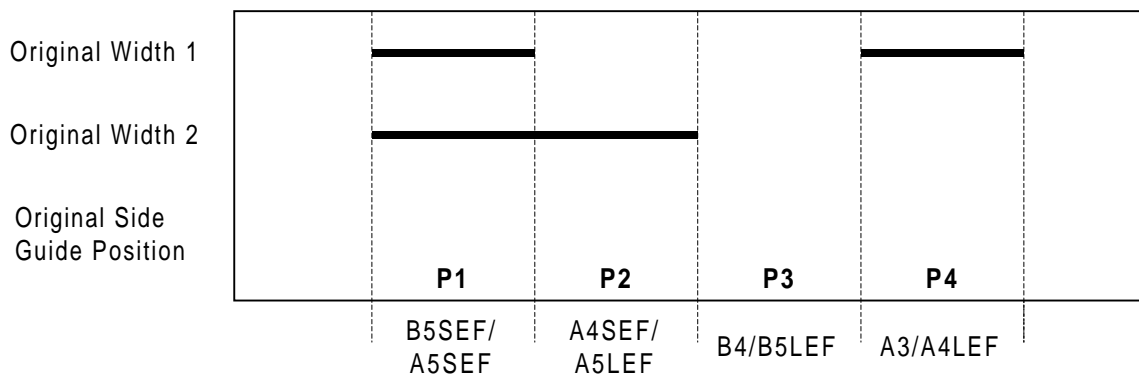

ARDF
B379

2.2 PICK-UP AND SEPARATION

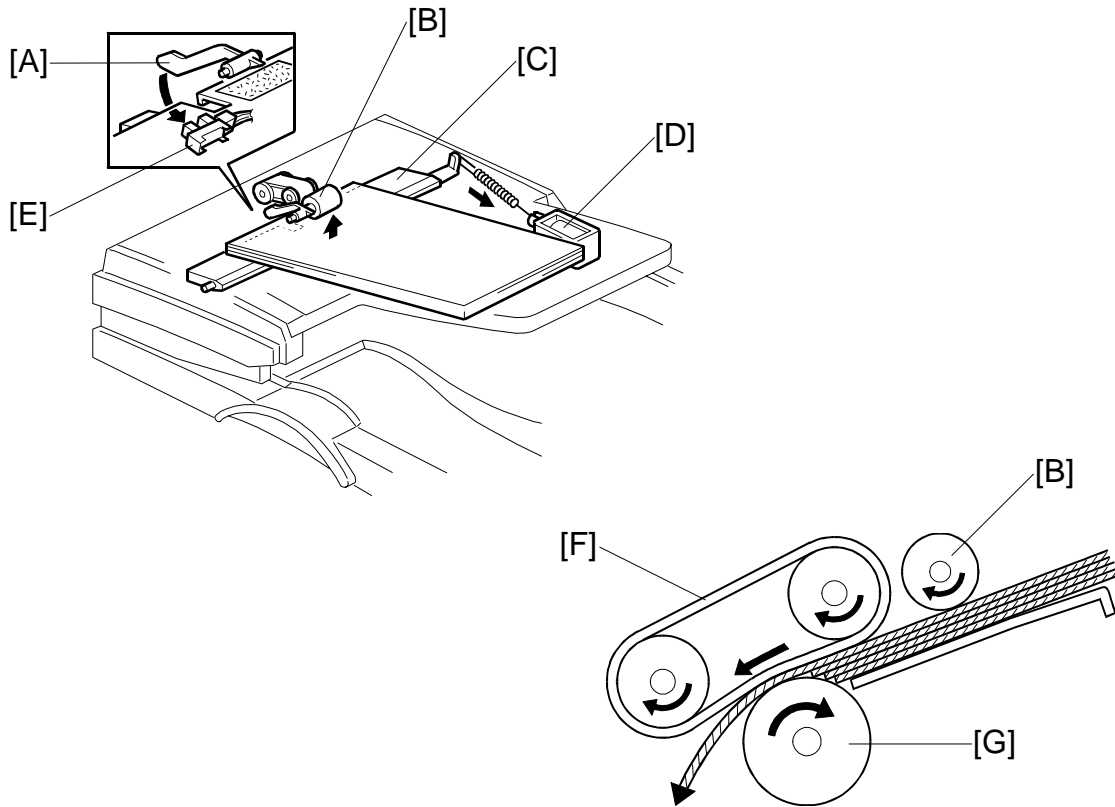

The original is set with the image facing up. The original pushes actuator [A] and the original set sensor [E] is activated.

After pressing the start button, the pick-up solenoid [D] is activated and the lift plate [C] lifts the original up until it comes in contact with the pick-up roller [B]. The pick-up roller then feeds the top sheet of paper.

After being fed from the pick-up roller, the topmost sheet is separated from the stack by the separation roller and sent to the first transport roller.

The mechanism is an FRR system, consisting of the original feed belt [F] and separation roller [G].

2.3 ORIGINAL TRANSPORT AND EXIT

2.3.1 SINGLE-SIDED ORIGINALS

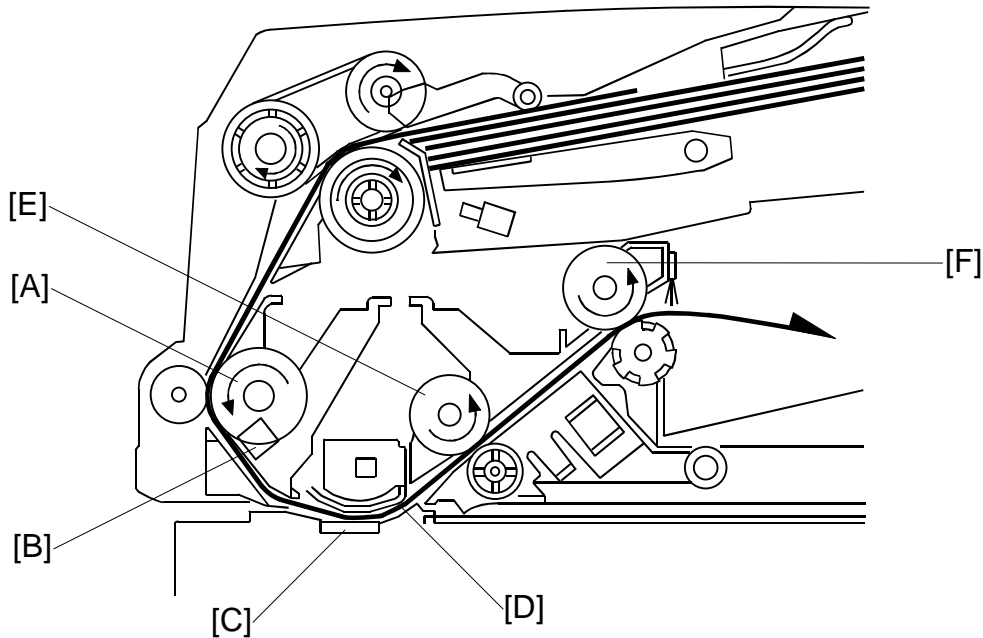

The DF feed motor feeds the separated original to the first transport roller [A] at maximum speed. When the registration sensor [B] detects the leading edge, the motor stops for a short while. Then the feed and transport motors turn on again, and feed the original through the scanning area at a lower speed (the scanning area contains the original exposure guide [D] and DF exposure glass [C]). After scanning, the original is fed out by the second transport roller [E] and exit roller [F].

2.3.2 DOUBLE-SIDED ORIGINALS

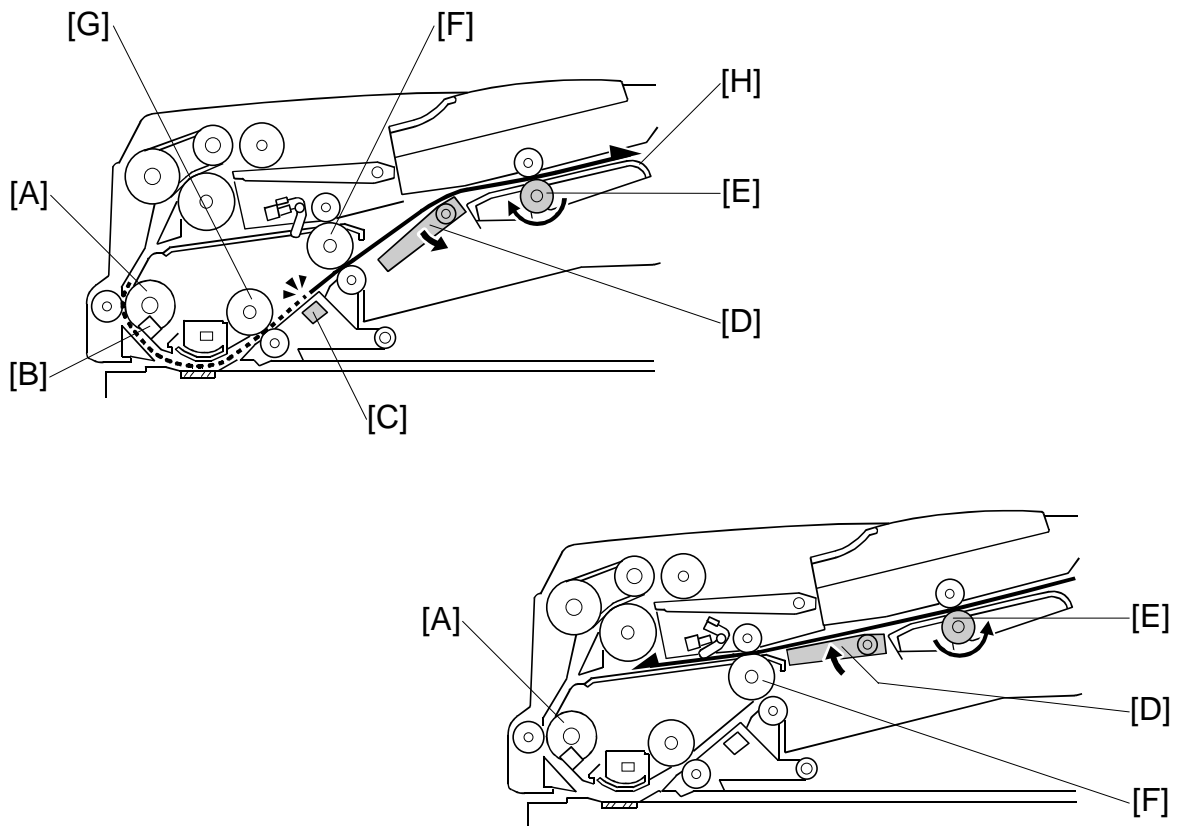

When the registration sensor [B] detects the leading edge of the original, the DF feed motor (which drives the feed roller) and transport motor (which drives the transport roller) both switch off. After a brief interval, the transport motor alone reactivates to drive the first transport roller [A] and second transport roller [G] and the exit roller [F]. The front side of the original is then scanned.

When the original exit sensor [C] detects the leading edge of the original, the junction gate solenoid is activated and the junction gate [D] opens. The original is then transported towards the reverse table [H].

Soon after the trailing edge of the original passes the exit sensor [C], the junction gate solenoid switches off and the junction gate [D] is closed. When the original has been fed onto the reverse table, the DF feed motor switches on in reverse. The original is then fed by the reverse roller [E] and then by the exit roller [F] and first transport roller [A] to the scanning area (where the reverse side will be scanned).

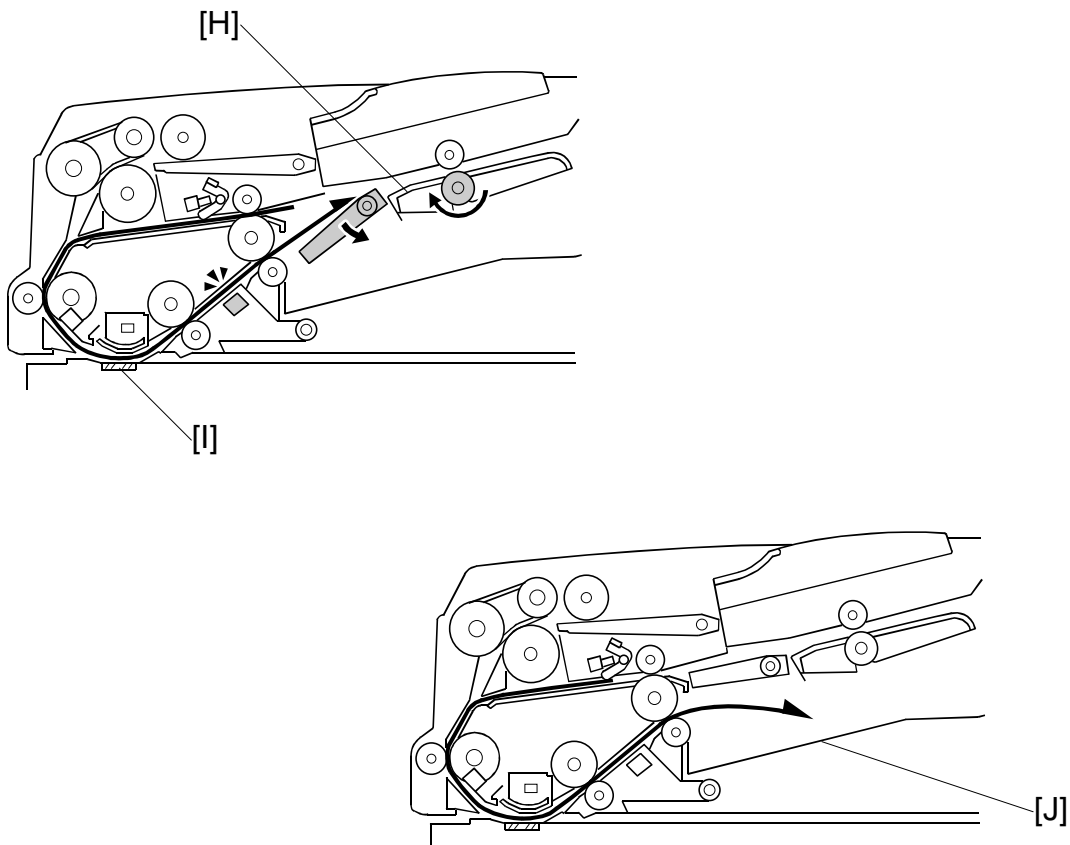

The original is then sent to the reverse table [H] a second time to be turned over. This is done so that the duplex copies will be properly stacked front side down in the exit tray [J] in the correct order.

2.3.3 ORIGINAL TRAILING EDGE SENSOR

During one-to-one copying, copy paper is fed to the registration roller in advance (while the original is still being scanned), to increase the copy speed. The trailing edge sensor monitors the stack of originals in the feeder, and detects when the trailing edge of the last page has been fed in. The main CPU then stops the copier from feeding an unwanted extra sheet of copy paper.

ARDF
B379

STAMP

2.4 STAMP

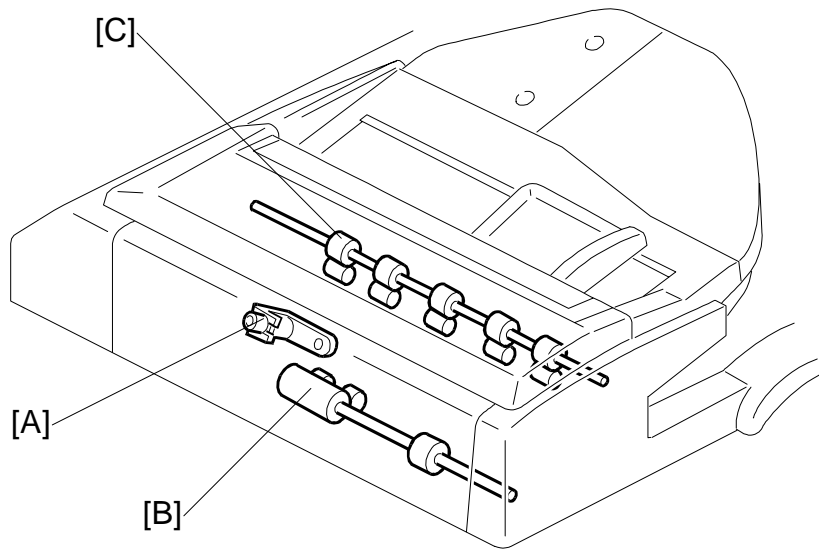

This function is only for fax mode.

There is a stamp [A] between the 2nd transport roller [B] and the exit roller [C], and its solenoid is controlled by the copier directly.

When the original reaches the stamp position, the DF feed motor stops. At 300 milliseconds after stopping the DF feed motor, the stamp solenoid turns on if the page was sent successfully (immediate transmission) or stored successfully (memory transmission). After stamping, the DF feed motor starts again to feed out the document, and its speed is about 1.3 times the normal speed.

The stamping position on the original can be changed by adjusting SP6-010.

2.5 TIMING CHARTS

2.5.1 SINGLE-SIDED ORIGINAL MODE (A3)

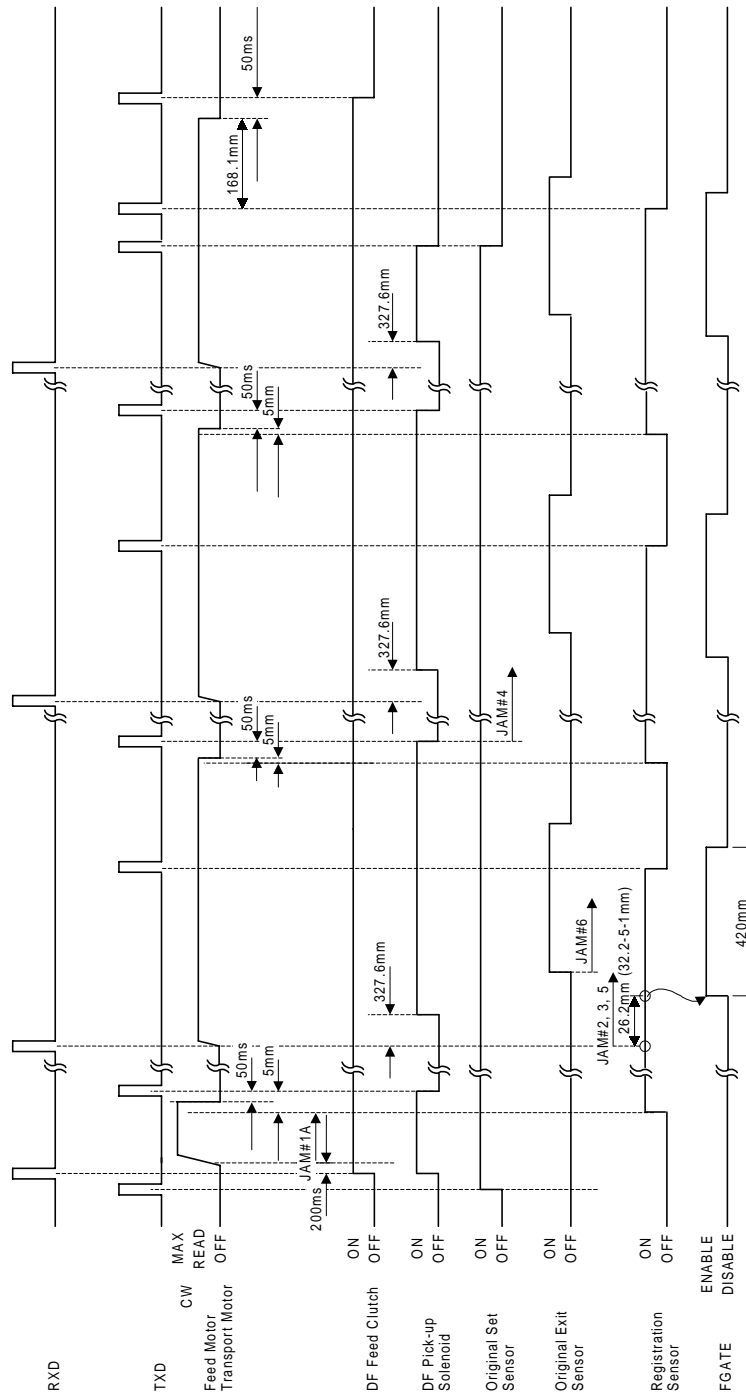

2.5.3 DOUBLE-SIDED ORIGINAL MODE

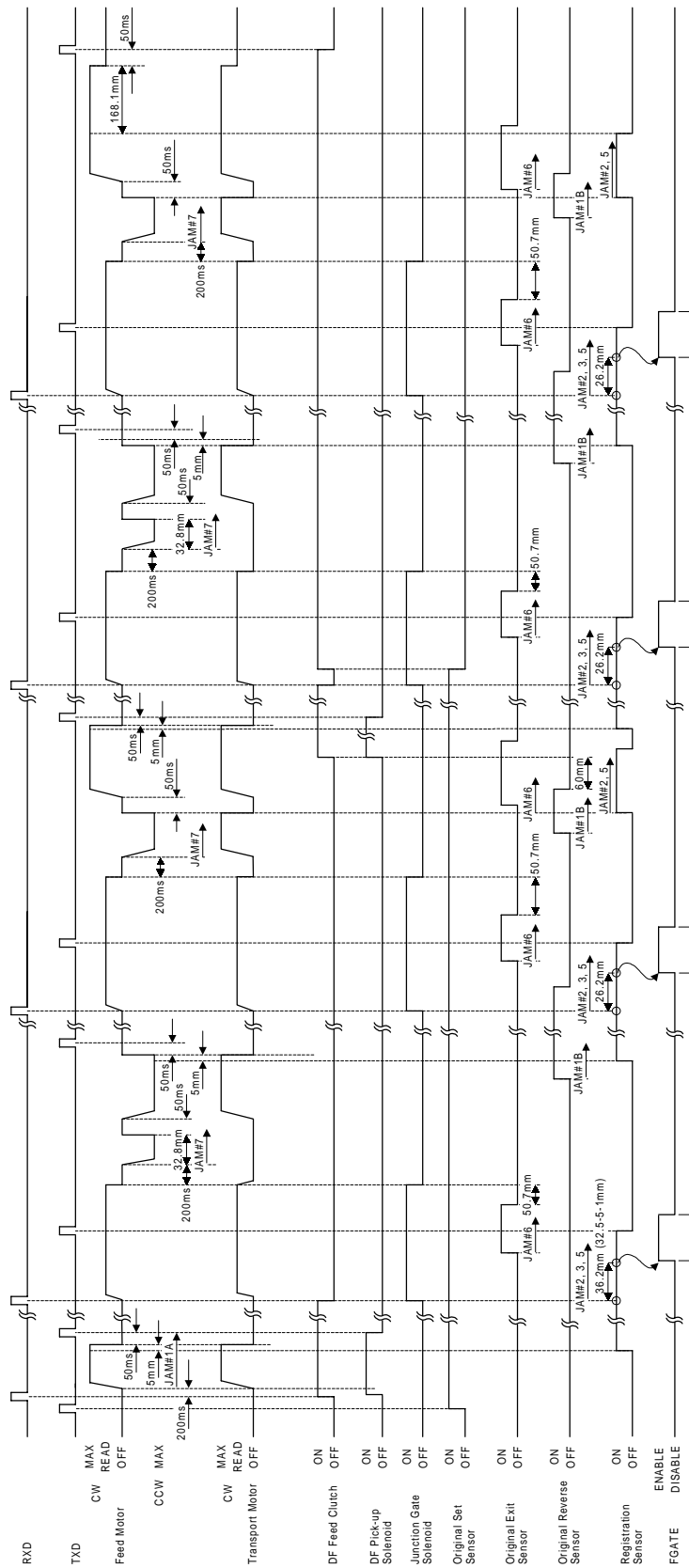

ARDF
B379

TIMING CHARTS

2.5.4 DOUBLE-SIDED ORIGINAL MODE (STAMP MODE)

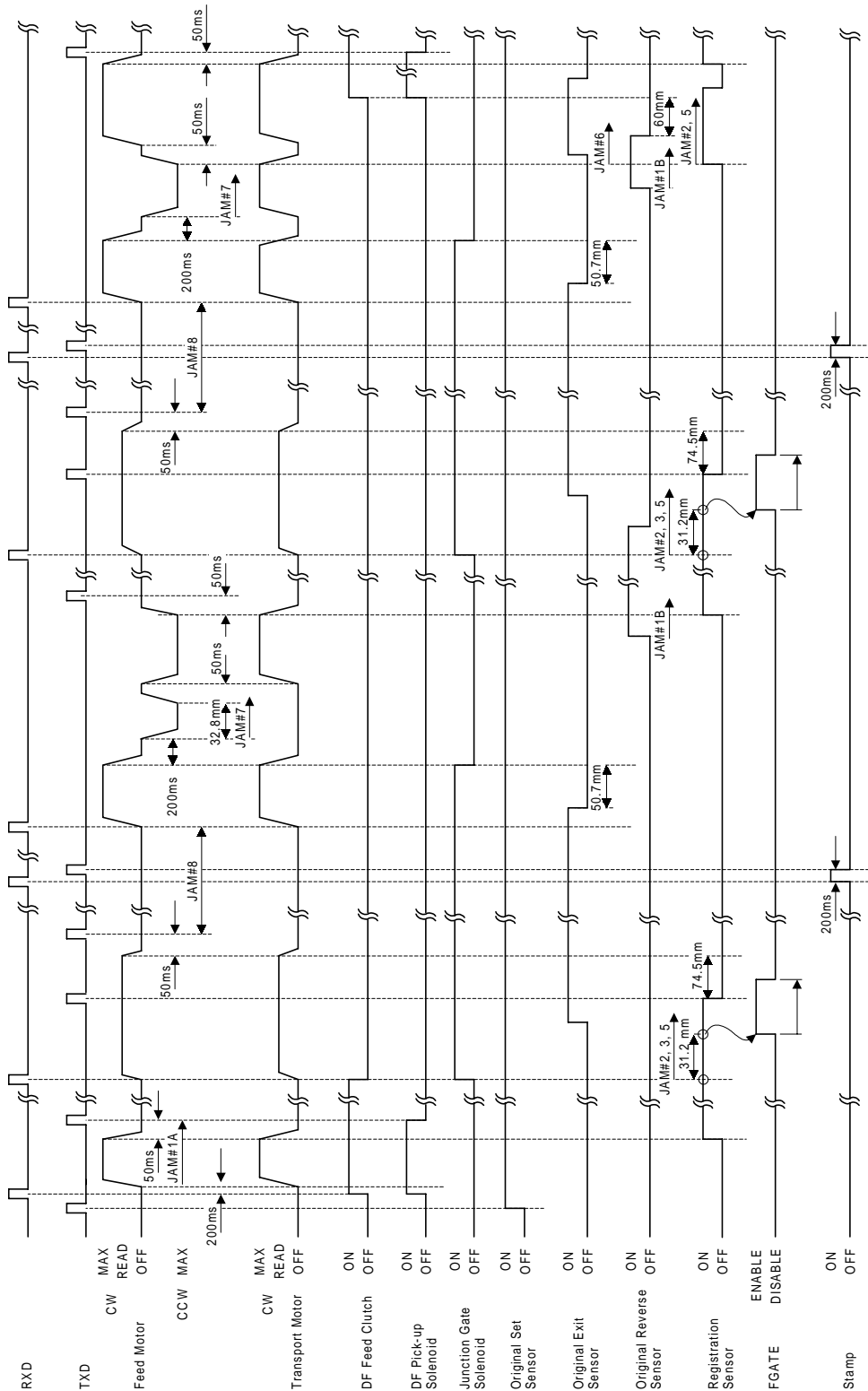

2.6 JAM DETECTION

- JAM 1A:** If the registration sensor does not turn on within X1 ms after original feed starts.

$$X1 = (114 \times 1.1)/\text{line speed} + 2,000 \text{ ms}$$
- JAM 1B:** If the registration sensor does not turn on within 685 ms after the leading edge of the original reaches the original reverse sensor (duplex mode only)
- JAM 2:** If the registration sensor does not turn off within X2 ms after turning on.

$$X2 = (\text{Original length}/\text{line speed}) + 2,000 \text{ ms}$$
- JAM 3:** If there is no original at the registration sensor when scanning is started, even though the sensor had already turned on.
 The operator may then remove the original from the ADF.
- JAM 4:** The current original is stopped after the registration sensor detects its leading edge, but the previous original is still at the scanning position.
- JAM 5:** If the original exit sensor does not turn on within X3 ms after the registration sensor turns on.

$$X3 = 140 \text{ mm}/\text{line speed}$$
- JAM 6:** If the original exit sensor does not turn off within X4 ms after the original exit sensor turns on.

$$X4 = (\text{Original length}/\text{line speed}) + 2,000 \text{ ms}$$
- JAM 7:** If the original reverse sensor does not turn on within 2,329 ms after the reversing process begins (Duplex mode only).
- JAM 8:** If the original stopped at the stamp position is removed.
- JAM 9:** If the cover is opened or the ADF is lifted up while the ADF is in operation.
- JAM 10:** If the DF gate signal (indicating that the original is now in the correct position for scanning) is not asserted when the original trailing edge passes the DF exposure glass.
 JAM 10 occurs when the original is pulled out while it is being scanned.

2.7 OVERALL ELECTRICAL CIRCUIT

The DF CPU controls the transport motor, DF feed motor, DF feed clutch, junction gate solenoid, stamp solenoid, and pick-up solenoid. The DF CPU also monitors all DF sensors and provides updated status information when prompted at regular intervals by the mainframe, which may then take action based on this information. The DF-mainframe connection is checked automatically just after power is supplied to the mainframe.

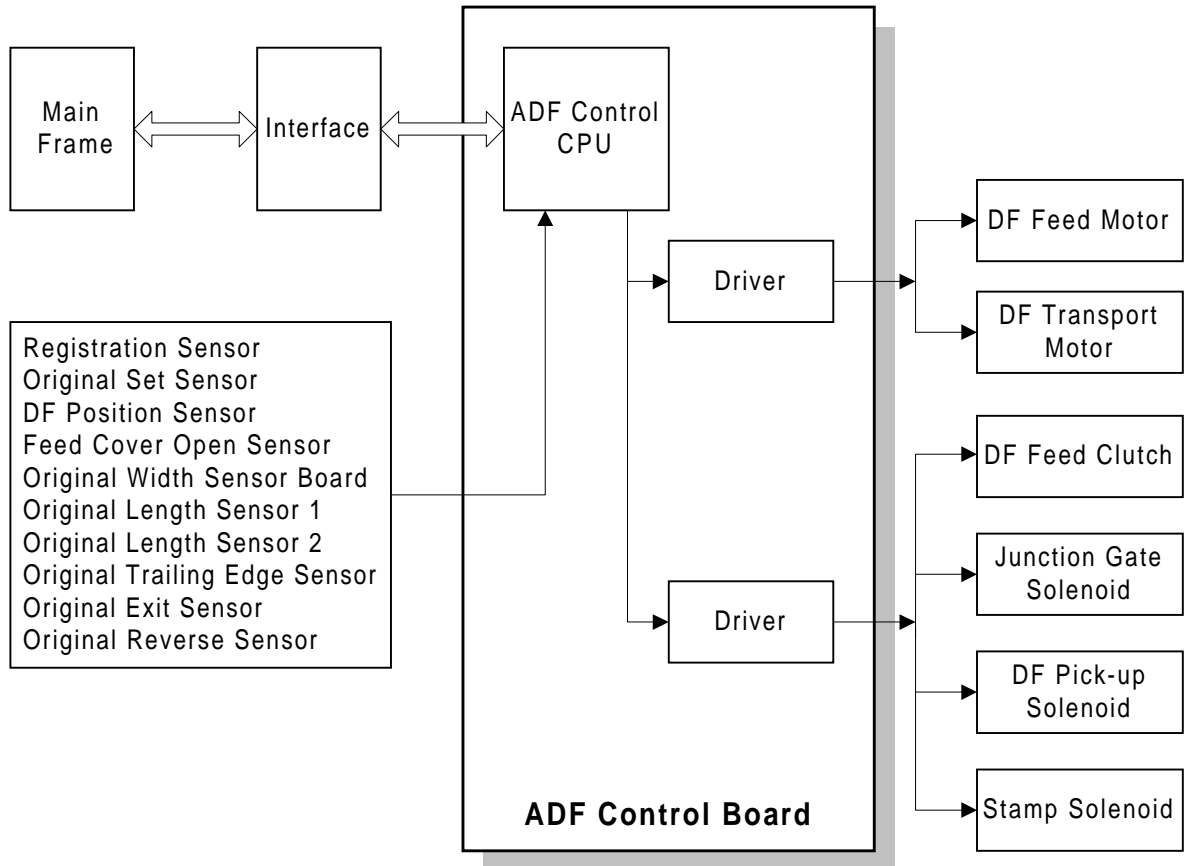

2.8 FREE RUN

Two types of free runs can be performed by using Dip Switch DPS 100 on the DF control board. The switch settings are as follows:

DPS 100

SW				
1	OFF	ON	OFF	ON
2	OFF	OFF	ON	ON
Mode	Normal	A	B	(*See below)

A: One-sided free run

B: Two-sided free run

*: When both switches have been switched to ON:

If SW 1 was turned ON first, Mode A is enabled. If SW 2 was turned ON first, Mode B is enabled.

Procedure

1. Turn on SW 1 or 2 (DPS 100 on DF control board).
2. Set the original on the original table.
3. After 2 seconds, the free run will automatically start.
4. To stop the free run, turn all DIP switches OFF, then turn the main power off and on.

One-sided Free Run Process

1. The originals are set on the original table.
2. The first page of the original is fed into the DF.
3. The sensors detect the original.
4. The original is output to the exit tray.
5. Steps 2-4 above are repeated for any additional originals set on the original table. If there are no additional originals, the DF will stop and wait.

Two-sided Free Run Process

The process is the same, except that the original reverse cycle is added.

3. REPLACEMENT AND ADJUSTMENT

3.1 DF EXIT TABLE AND COVER

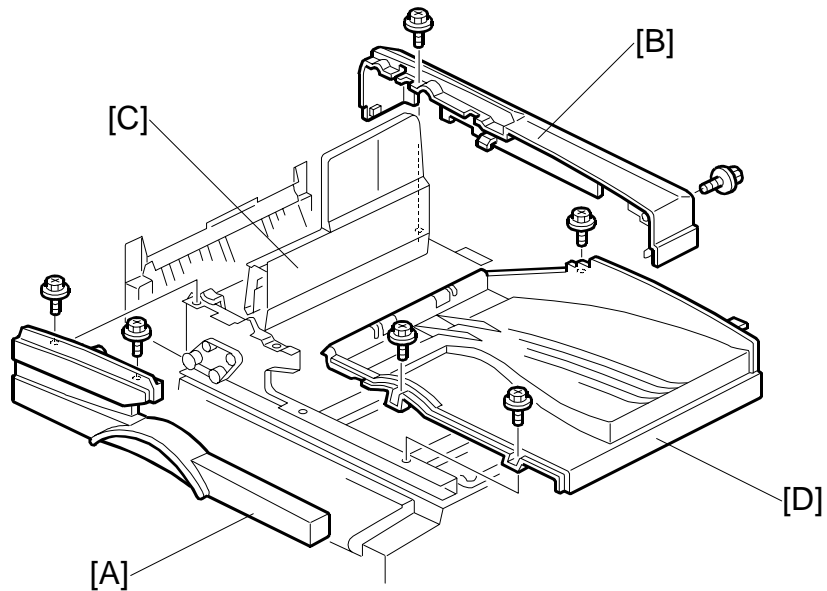

1. Open the left cover.
2. [A] Front cover (🔩 x 2)
3. [B] Rear cover (🔩 x 2). Take care not to break the 3 hooks.
4. [C] Open the reverse table
5. [D] Original exit table (🔩 x 3)

3.2 ORIGINAL FEED UNIT

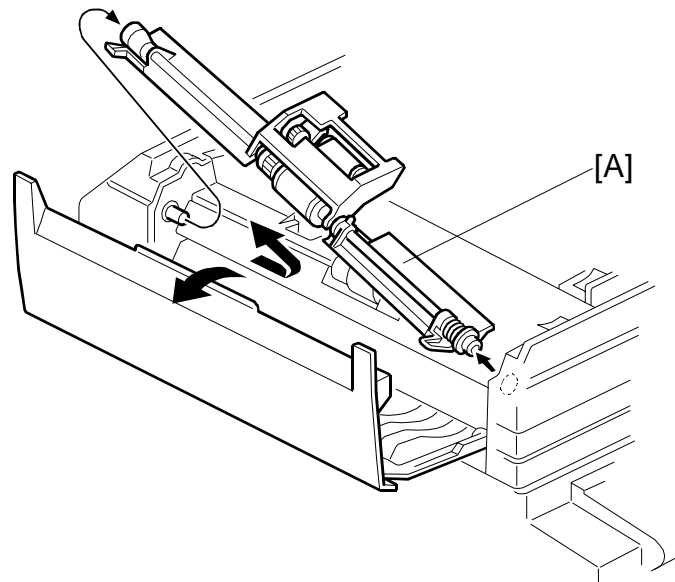

1. Open the left cover.
2. [A] Original feed unit

ARDF
B379

LEFT COVER

3.3 LEFT COVER

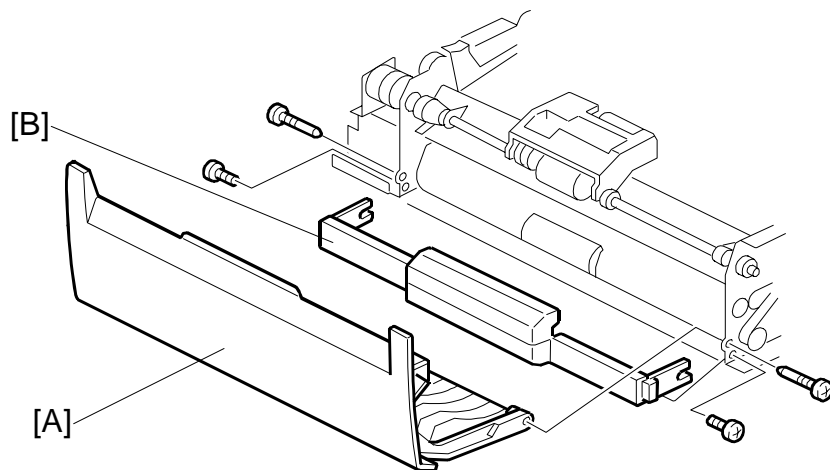

1. Front and rear covers (☛ 3.1)
2. [A] Left cover (🔩 x 2)
3. [B] Lower left stay unit (🔩 x 2)

3.4 PICK-UP ROLLER

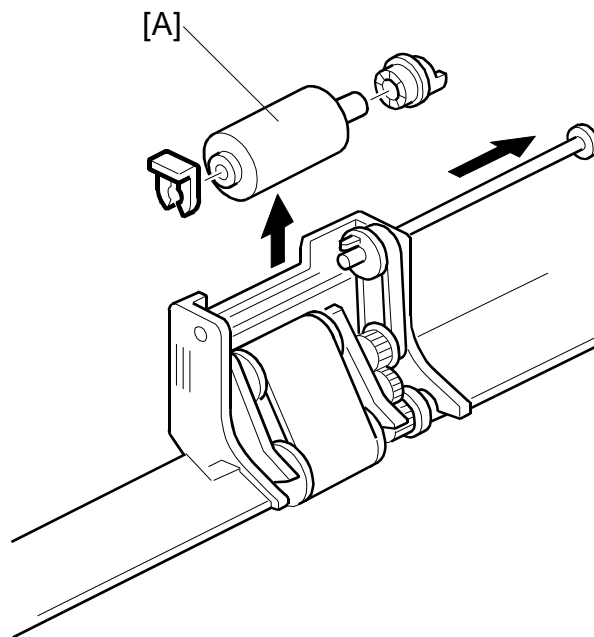

1. Original feed unit (☛ 3.2)
2. [A] Pick-up roller (1 snap ring)

FEED BELT

3.5 FEED BELT

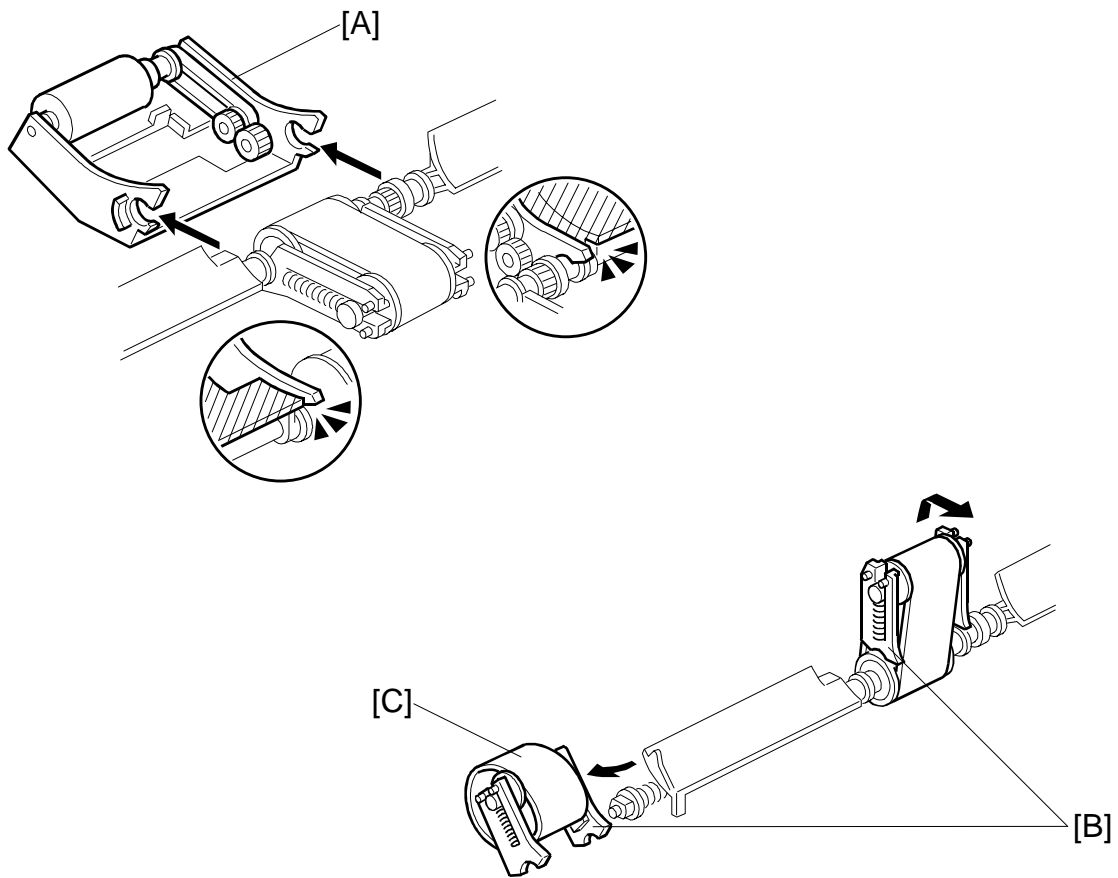

1. Original feed unit (☛ 3.2)
2. [A] Paper feed guide
3. [B] Belt holders
4. [C] Feed belt

3.6 SEPARATION ROLLER

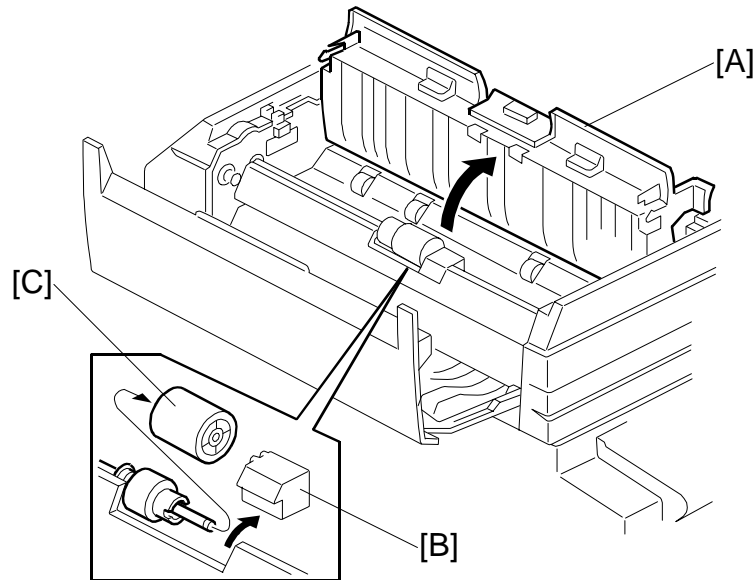

1. Lift the original feed guide [A].
2. [B] Separation roller cover
3. [C] Separation roller

ARDF
B379

3.7 ORIGINAL SET/ORIGINAL REVERSE SENSORS

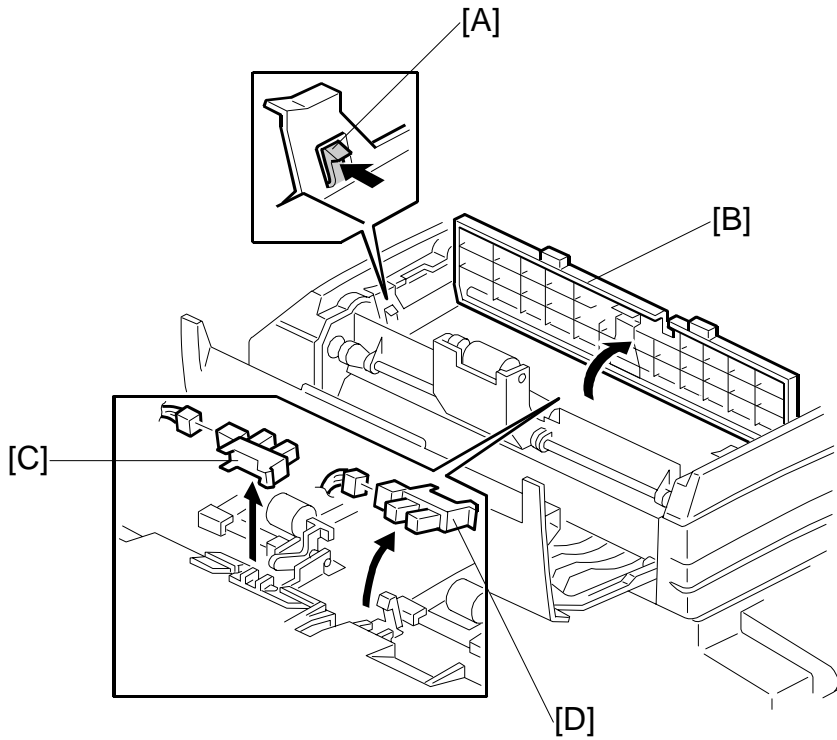

1. Open the left cover.
2. While pushing the left and right pawls [A], open the original feed guide plate [B].
3. [C] Original set sensor (☞ x 1)
4. [D] Original reverse sensor (☞ x 1)

3.8 ORIGINAL L/W SENSORS, TRAILING EDGE SENSOR

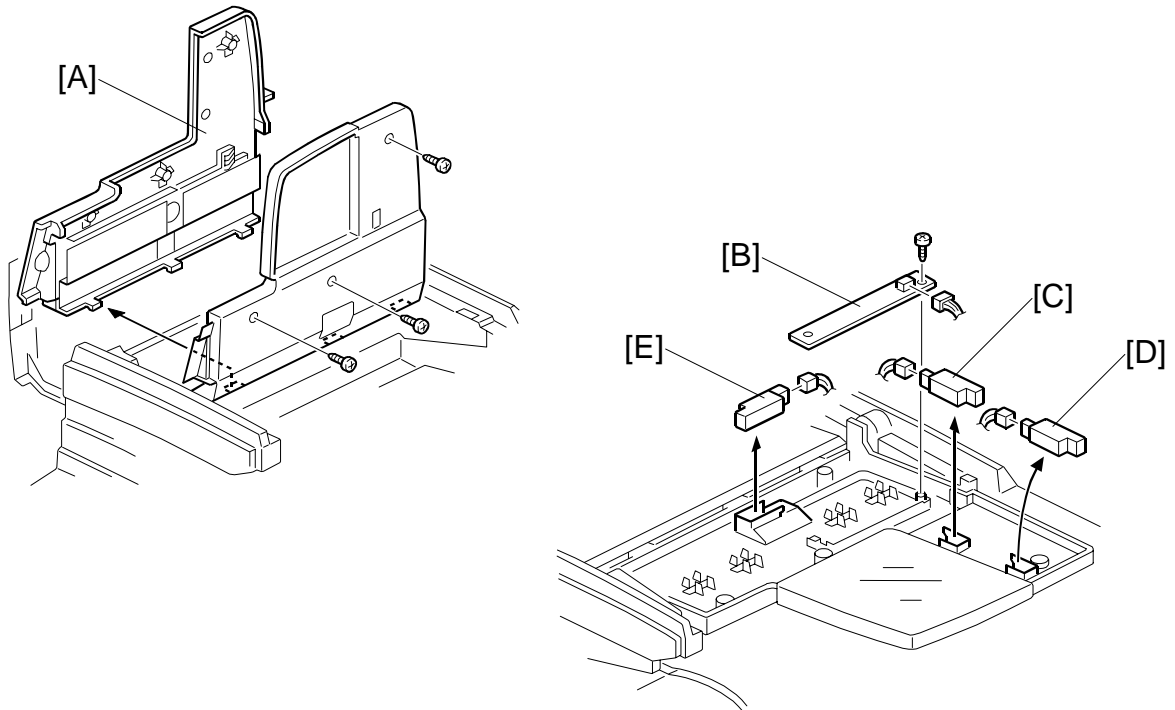

1. Open the original table.
2. [A] Upper part of the table (🔩 x 3)
3. [B] Width sensor board (🔩 x 1)
4. [C] Length sensor-1 (🔩 x 1)
5. [D] Length sensor-2 (🔩 x 1)
6. [E] Trailing edge sensor (🔩 x 1)

To ensure proper detection of paper size, after wiping off the sensor board and terminal plate with a dry cloth (or cloth with alcohol), apply silicone grease (KS-660) to the terminal plate [G].

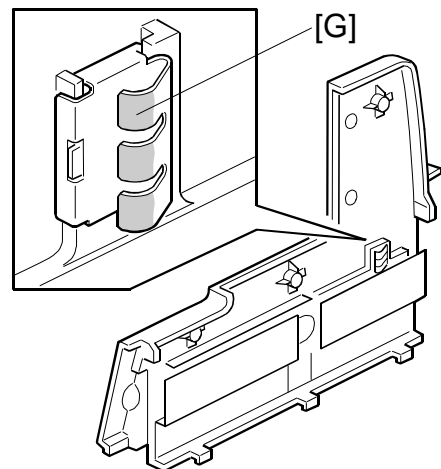

ARDF
B379

3.9 FEED CLUTCH, PICK-UP SOL, TRANSPORT MOTOR, FEED MOTOR

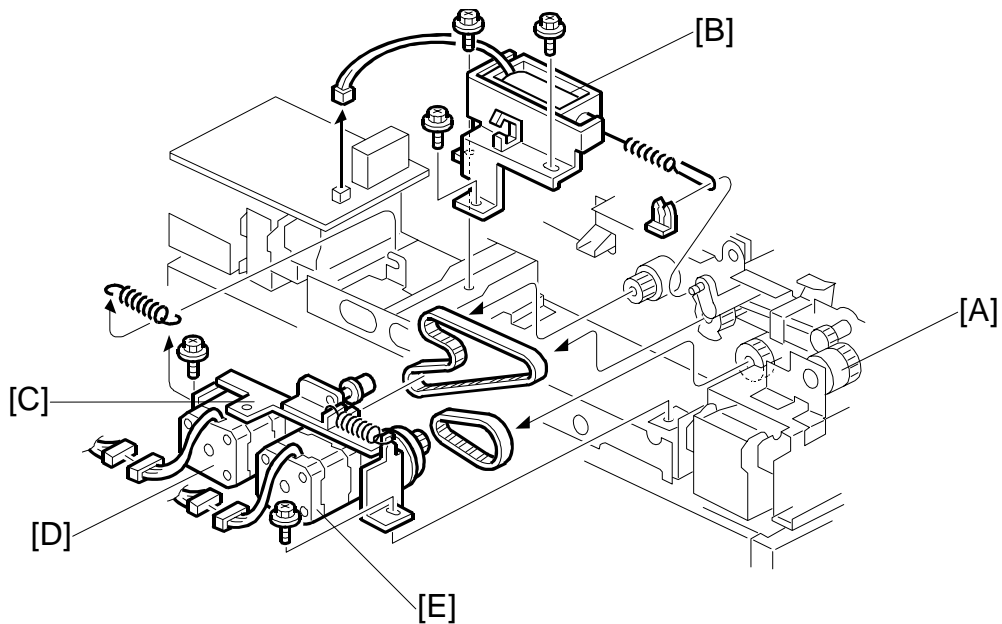

Exterior

1. Rear cover (☞ 3.1)

DF Feed Clutch

1. [A] DF feed clutch [A] (☞ x 1, ☞ x 1)

Pick-up Solenoid

1. [B] Pick-up solenoid (☞ x 3, 1 snap ring, ☞ x 1)

Transport Motor

1. [C] Bracket (☞ x 2)
2. [E] Transport motor (☞ x 2, ☞ x 1)

DF Feed Motor

1. [C] Bracket (☞ x 2)
2. [D] DF feed motor (☞ x 2, ☞ x 1)

3.10 REGISTRATION SENSOR

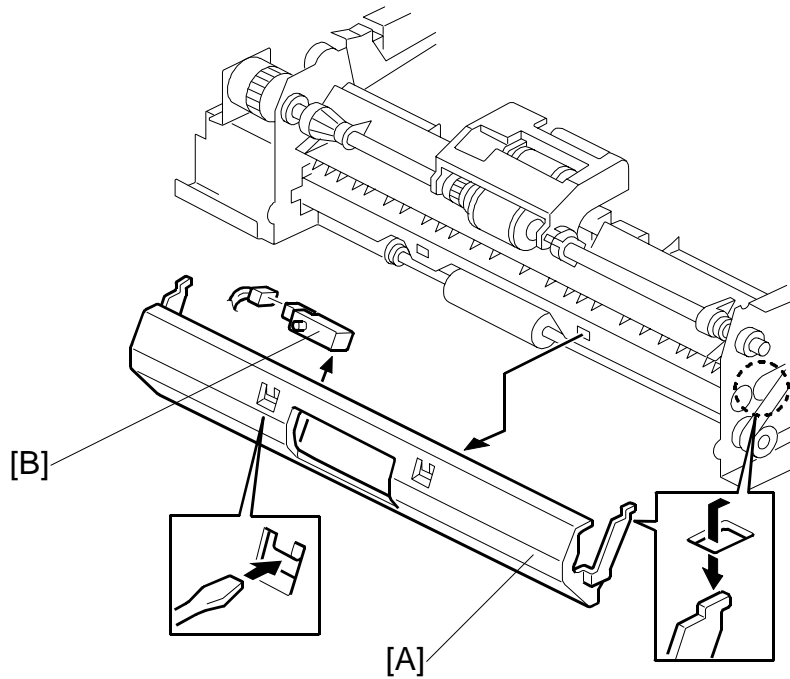

1. Front and rear covers (☛ 3.1)
2. Left cover and lower left stay unit (☛ 3.3)
3. [A] Transport guide plate
4. [B] Registration sensor (☛ x 1)

ARDF
B379

3.11 STAMP SOLENOID AND ORIGINAL EXIT SENSOR

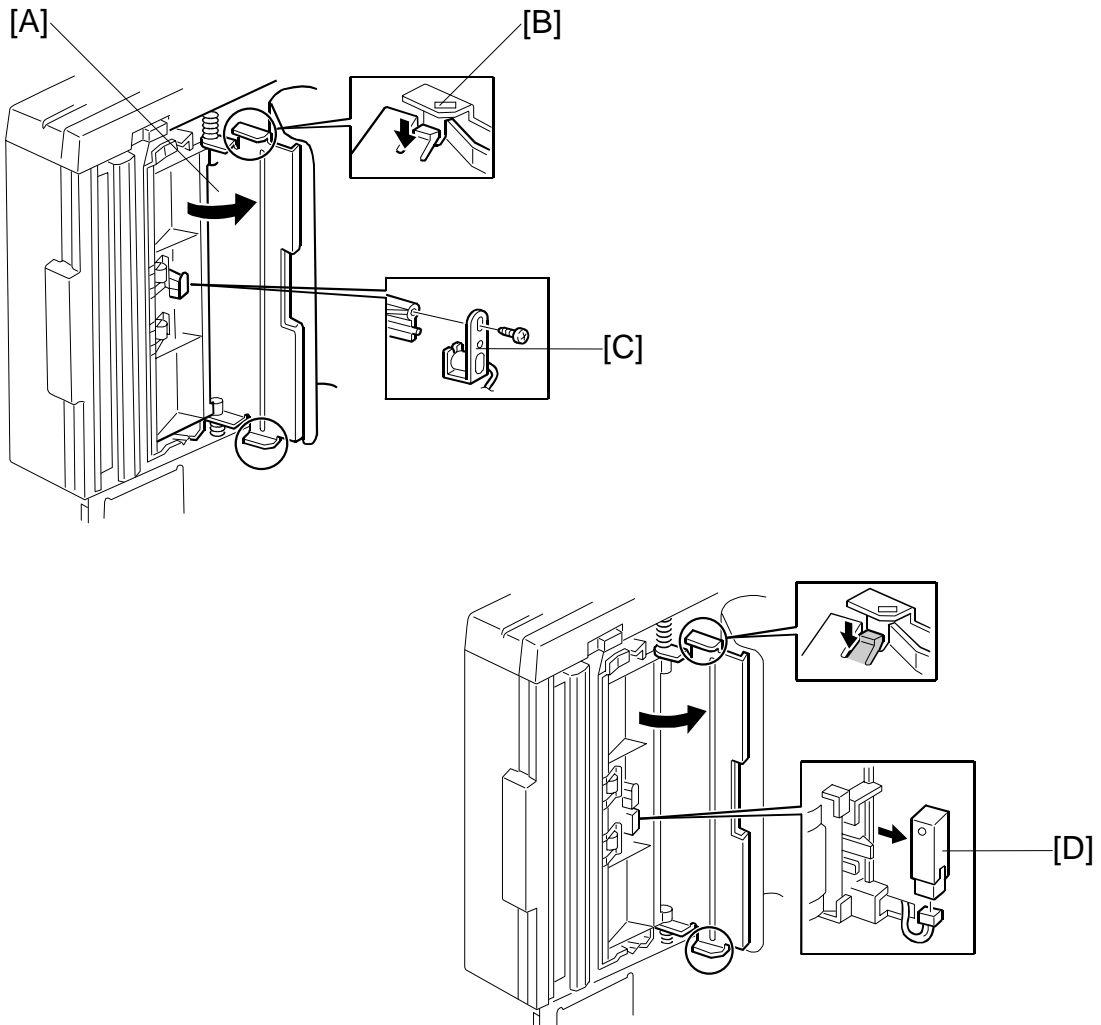

1. Front cover, Rear cover, Original exit table (☛ 3.1)
2. Open the exit guide plate [A]. Next, detach the unit by inserting a screwdriver or other tool into one of the small openings [B] on either side of the guide plate holder and pushing firmly.
3. [C] Stamp solenoid (🔩 x 1 📏 x 1)
4. [D] Original exit sensor (📏 x 1)

DOCUMENT FEEDER B387

1. OVERALL INFORMATION

1.1 MECHANICAL COMPONENT LAYOUT

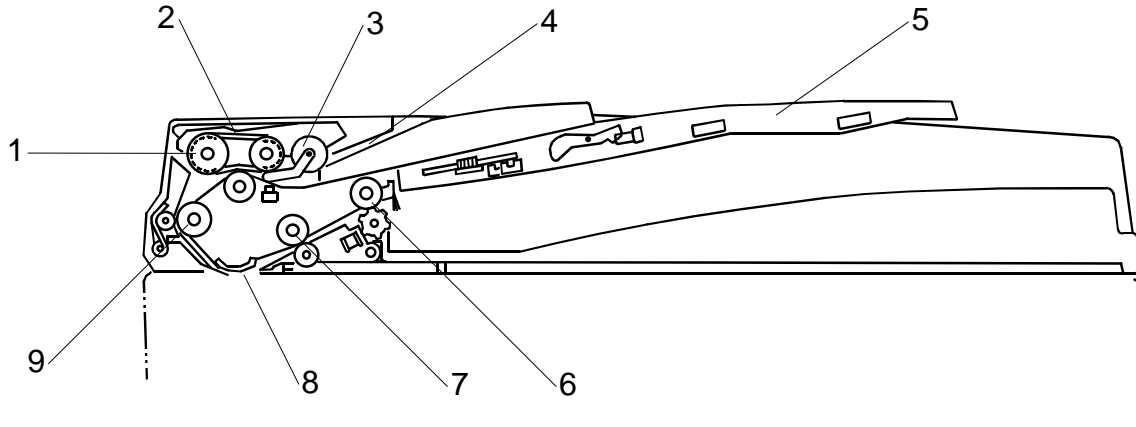

- | | |
|----------------------------|----------------------------|
| 1. Separation roller | 6. Original exit roller |
| 2. Original feed belt | 7. 2nd transport roller |
| 3. Pick-up roller | 8. Original exposure guide |
| 4. Original entrance guide | 9. 1st transport roller |
| 5. Original table | |

1.2 ELECTRICAL COMPONENT LAYOUT

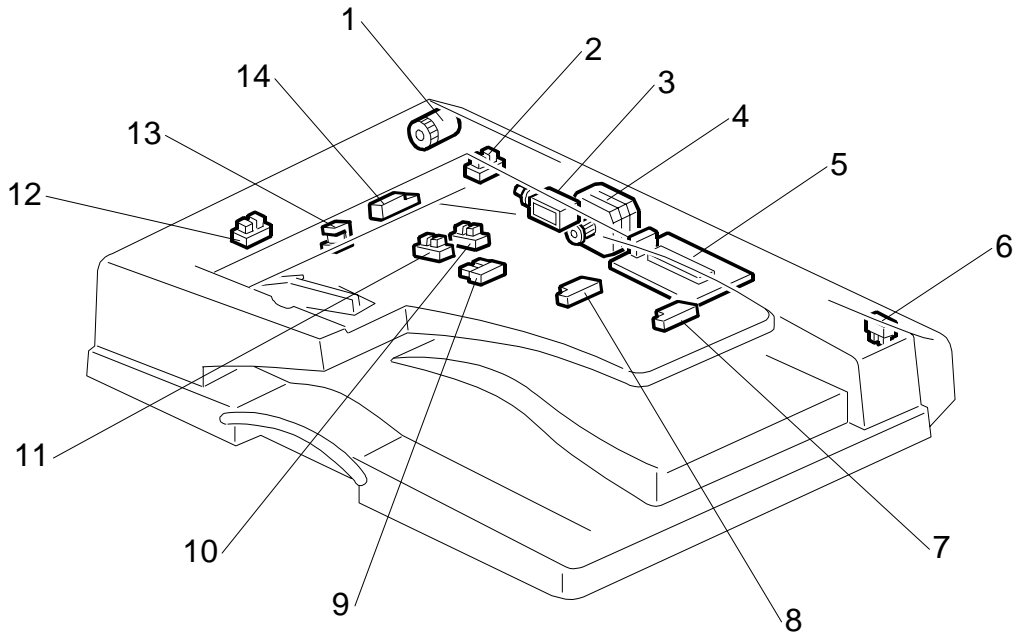

- | | |
|-----------------------------|----------------------------------|
| 1. DF feed clutch | 8. Original length sensor 1 |
| 2. Feed cover open sensor | 9. Original trailing edge sensor |
| 3. DF pick-up solenoid | 10. Original width sensor 1 |
| 4. DF transport motor | 11. Original width sensor 2 |
| 5. DF drive board | 12. Original set sensor |
| 6. DF open sensor | 13. Stamp solenoid |
| 7. Original length sensor 2 | 14. Registration sensor |

1.3 DRIVE LAYOUT

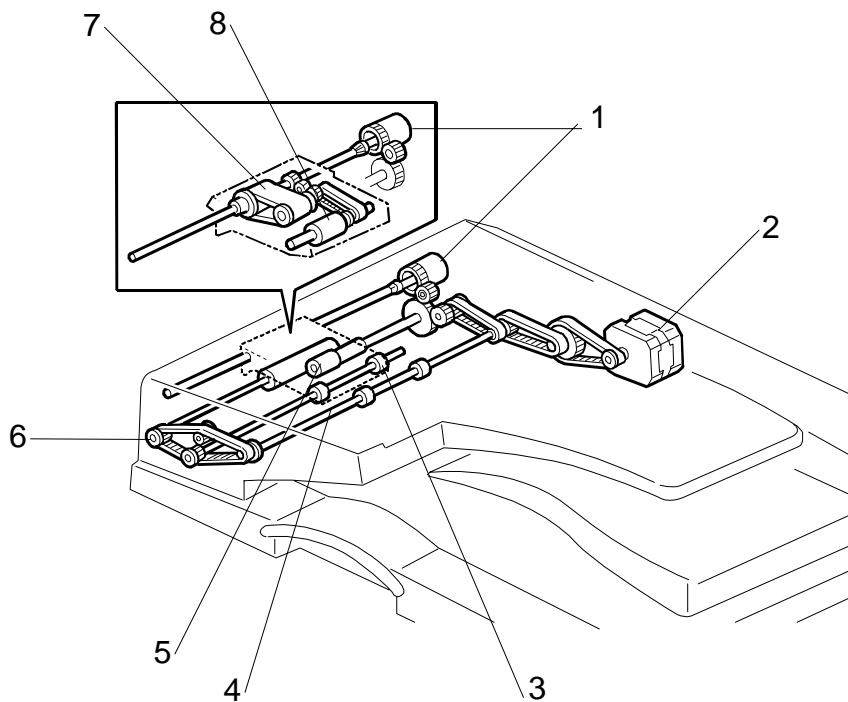

- | | |
|-------------------------|-------------------------|
| 1. DF feed clutch | 5. Separation roller |
| 2. DF transport motor | 6. 1st transport roller |
| 3. 2nd transport roller | 7. Original feed belt |
| 4. Exit roller | 8. Pick-up roller |

2. DETAILED SECTION DESCRIPTIONS

2.1 ORIGINAL SIZE DETECTION

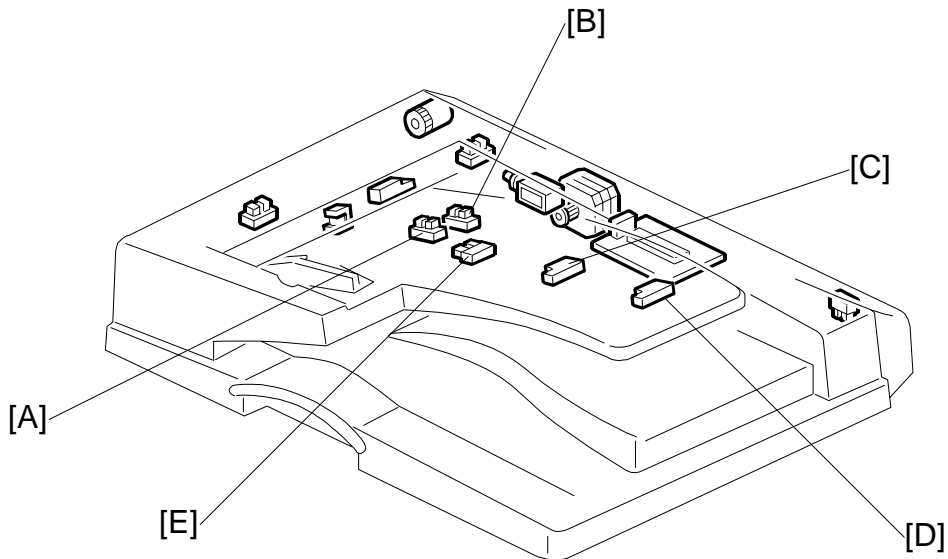

The DF uses two width sensors (width sensor 1 [A] and width sensor 2 [B]) to detect the original width, and two length sensors (length sensor 1 [C] and length sensor 2 [D]) to detect the original length. The DF detects the original size based on the combination of inputs from these sensors, as indicated in the table on the next page.

If using a non-standard original size, the user must input the original length at the operation panel.

The original width sensors have four possible output states: P1 to P4. The output depends on the position of the ridges on the toothed plate attached to the original rear fence.

During one-to-one copying, copy paper is fed to the registration roller in advance to increase the copy speed. The original exit trailing edge sensor [E] monitors the stack of originals in the feeder, and detects when the trailing edge of the last page has been fed in. This stops the ADF from causing the feed of an unwanted extra sheet of copy paper.

ORIGINAL SIZE DETECTION

		NA	EU	Original Length 1	Original Length 2	P1	P2	P3	P4
1	A3 (297 x 420)	X	○	ON	ON	-	-	-	ON
2	B4 (257 x 364)	X	○	ON	ON	-	-	ON	-
3	A4 SEF (210 x 297)	X	○	ON	-	-	ON	-	-
4	A4 LEF (297 x 210)	X	○	-	-	-	-	-	ON
5	B5 SEF (182 x 257)	X	○	ON	-	ON	-	-	-
6	B5 LEF (257 x 182)	X	○	-	-	-	-	ON	-
7	A5 SEF (148 x 210)	X	○	-	-	ON	-	-	-
8	A5 LEF (210 x 148)	X	○	-	-	-	ON	-	-
9	11" x 17"	○ ₁	X	ON	ON	-	-	-	ON
10	11" x 15"	● ₁	X	ON	ON	-	-	-	ON
11	10" x 14"	○	X	ON	ON	-	-	ON	-
12	8 1/2" x 14"	○ ₂	X	ON	ON	-	ON	-	-
13	8 1/2" x 13"	X	○ ₄	ON	ON	-	ON	-	-
14	8" x 13"	● ₂	● ₄	ON	ON	-	ON	-	-
15	8 1/2" x 11" SEF	○ ₃	X	ON	-	-	ON	-	-
16	11" x 8 1/2" LEF	○	X	-	-	-	-	-	ON
17	8" x 10" SEF	● ₃	X	ON	-	-	ON	-	-
18	5 1/2" x 8 1/2" SEF	○	X	-	-	ON	-	-	-
19	8 1/2" x 5 1/2" LEF	○	X	-	-	-	ON	-	-

NA: America (North, Middle, South) EU: Europe, Asia, China, Taiwan

X: No ○: Yes ON: Paper present

○₁, ●₁: In NA, original size 11" x 15" is detected as 11" x 17"

○₂, ●₂: In NA, original size 8" x 13" is detected as 8 1/2" x 14"

○₃, ●₃: In NA, original size 8" x 10" is detected as 8 1/2" x 11"

○₄, ●₄: In EU, original size 8" x 13" is detected as 8 1/2" x 13"

- Original Width Sensor States -

Width Sensor 1	High	Low	Low	High
Width Sensor 2	High	High	Low	Low
Detection State	P1	P2	P3	P4

Low = Blocked High = Open

1.2 PICK-UP AND SEPARATION

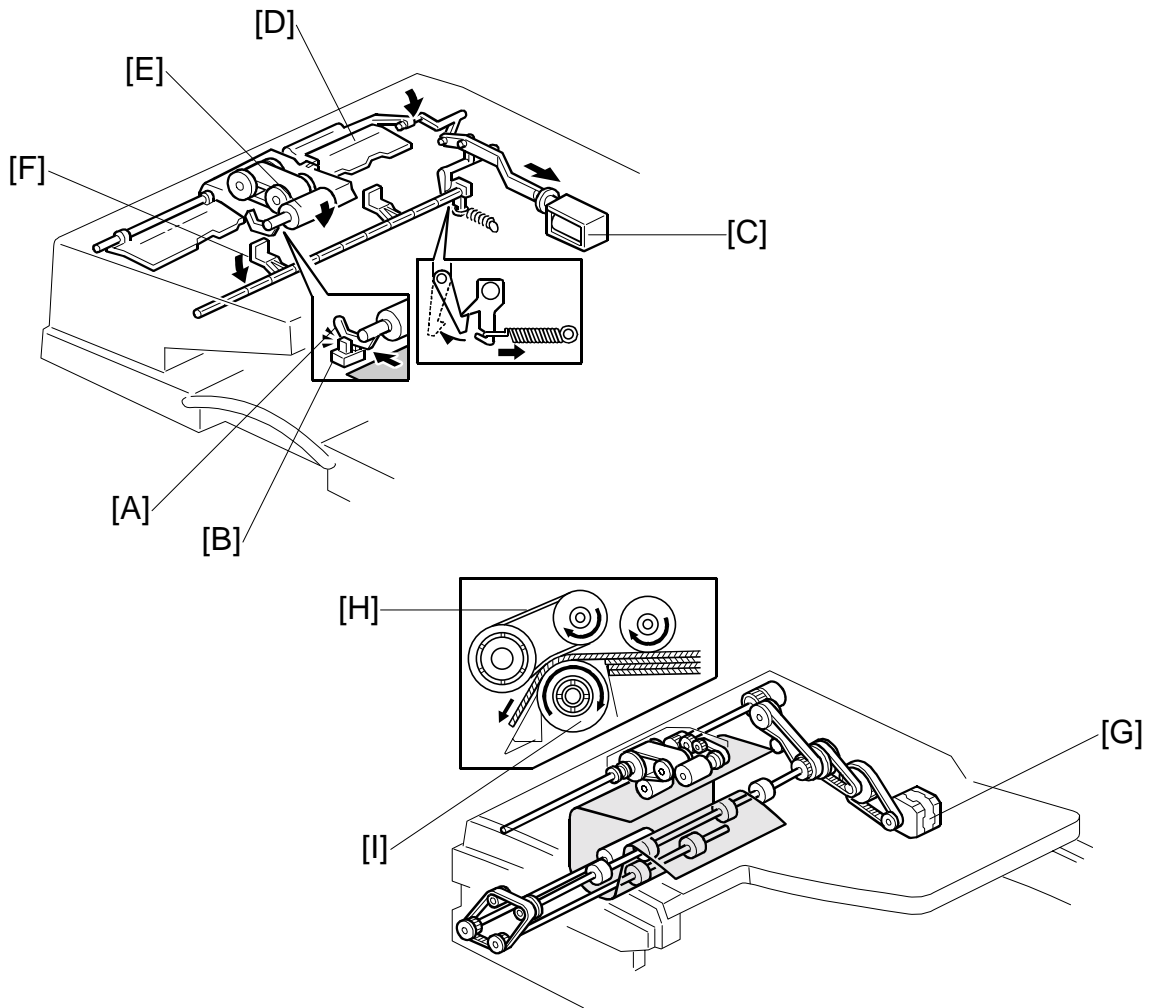

An FRR (feed and reverse roller) system is used.

Setting original(s) onto the feed table lifts the original set sensor feeler [A], causing the original set sensor [B] to issue a signal informing the main CPU that the DF is ready to start feeding.

When the Start key (Ⓢ) is pressed, the DF pick-up solenoid [C] turns on, causing the transport guide [D] and pick-up roller [E] to lower onto the original, while at the same time causing the original stoppers [F] to drop down to clear the feed path for the original. After 200 ms, the DF transport motor [G] turns on, feeding the top original page to the paper feed belt [H], where it is separated by the separation roller [I].

1.3 ORIGINAL TRANSPORT AND EXIT MECHANISM

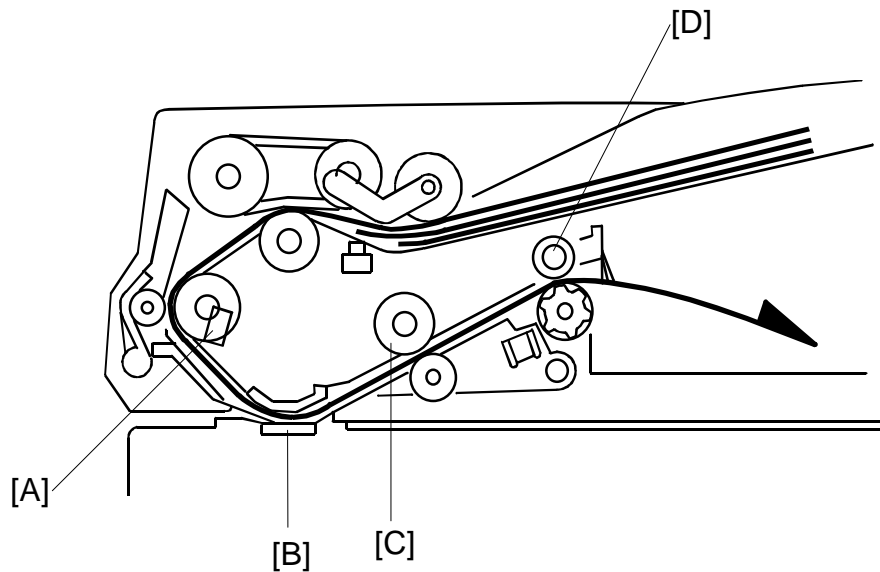

When the leading edge of the original reaches the registration sensor at [A], the DF transport motor turns off. After a short time the DF transport motor turns on again. The original is fed past the DF exposure glass [B], where it is scanned. It is then fed through to the 2nd transport roller [C] and fed out by the exit roller [D].

The DF transport motor uses a constant speed to feed the original up to the registration sensor. When the motor turns on again to feed the original to the DF exposure glass, however, the speed depends on the selected reproduction ratio. At 100%, the speed is 89 mm/s.

STAMP

1.4 STAMP

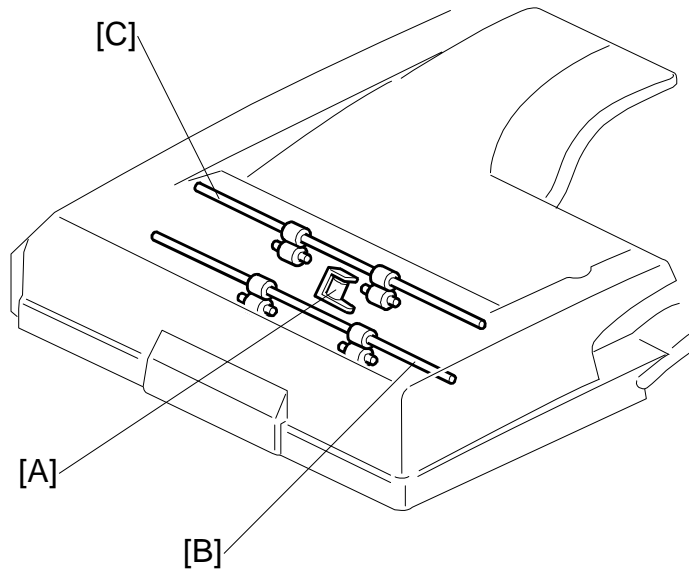

This function is only for fax mode. The fax unit includes the stamp.

The stamp solenoid [A] is located between the 2nd transport roller [B] and the exit roller [C]. The copier controls this solenoid directly.

When the original reaches the stamp position, the DF transport motor stops. Provided that the page was sent successfully (immediate transmission) or stored successfully (memory transmission), the stamp solenoid then comes on 300 ms after the DF motor stops. After stamping, the DF transport motor resumes feeding, at about 1.3 times the normal speed.

The positioning of the stamp on the original can be adjusted using SP6-010.

1.5 TIMING CHARTS

1.5.1 A3

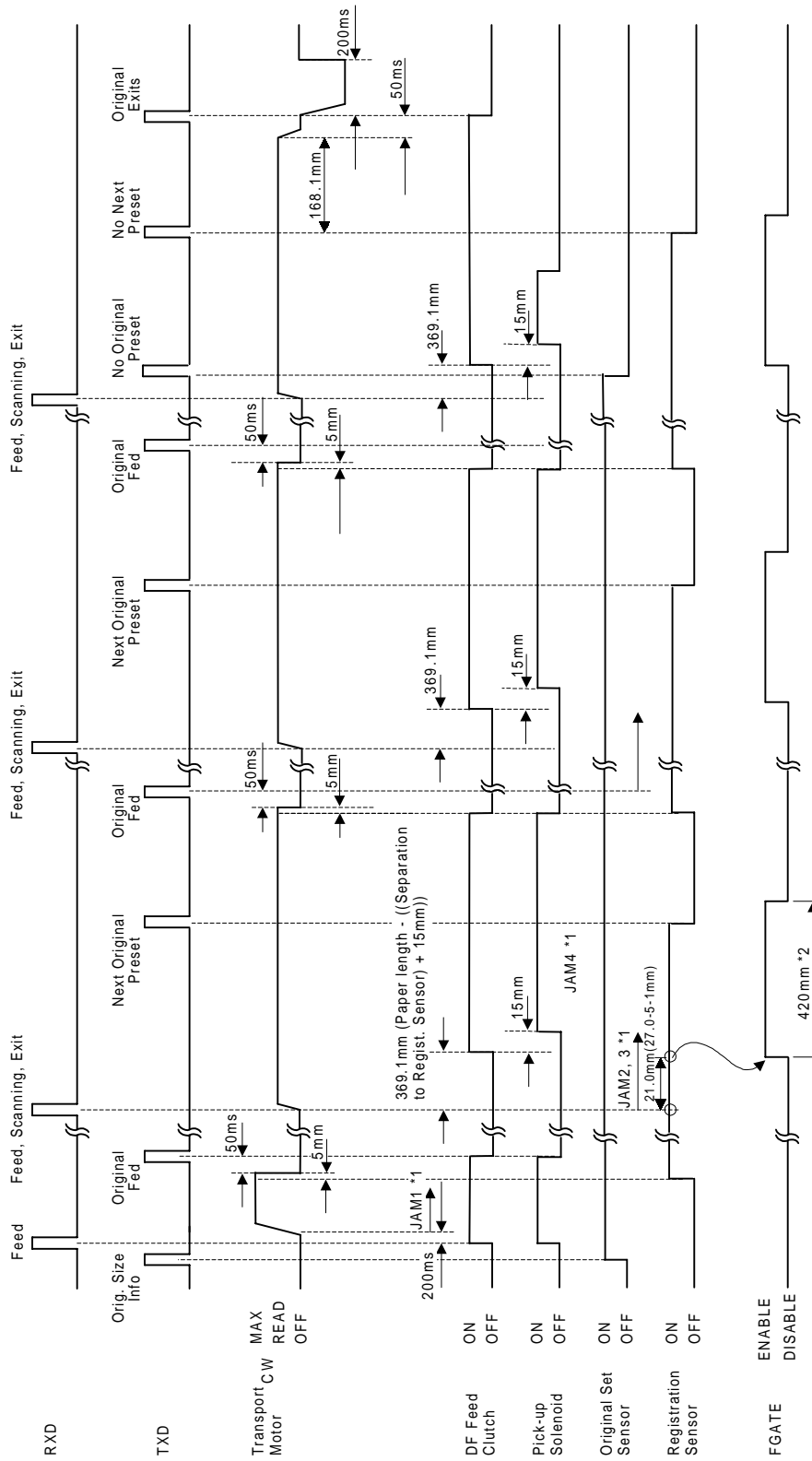

*1 For information about jam conditions, see Section 1.6.

*2 F Gate: This signal goes high when the laser start to wire a pate to the drum. The distance depends on SP mode setting 6-006-2 and -3.

TIMING CHARTS

1.5.2 A3, STAMP MODE

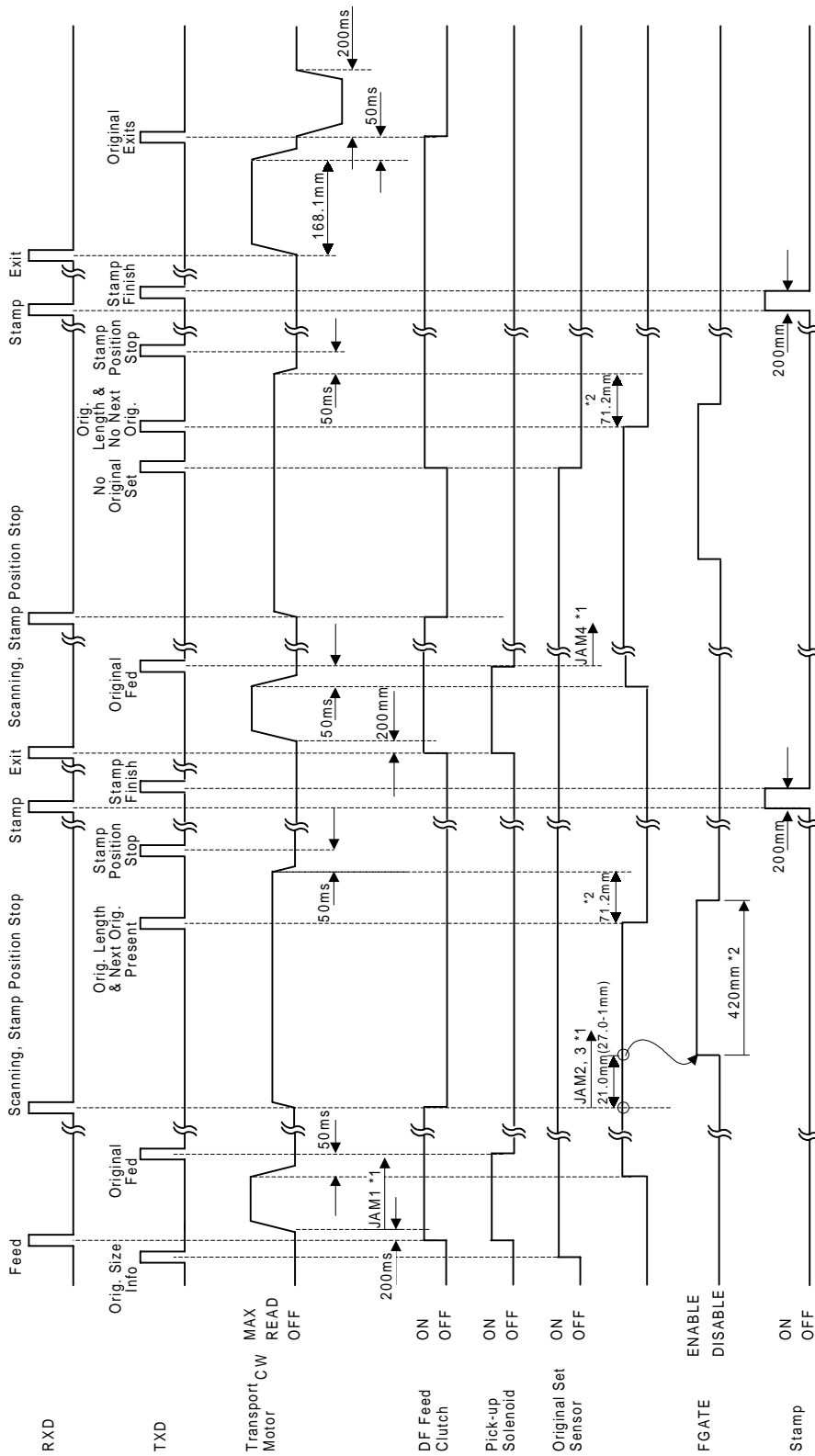

*1 For information about jam conditions, see Section 1.6.

*2 F Gate: This signal goes high when the laser start to wire a pate to the drum. The distance depends on SP mode setting 6-006-2 and -3.

1.6 JAM DETECTION

JAM 1: If the registration sensor fails to turn on within x_1 ms after the DF transport motor comes on to feed the original from the original tray.

$$x_1 = (114 \times 1.1) / \text{original speed} + 2,000 \text{ ms}$$

JAM 2: If the registration sensor fails to turn off within x_2 ms after the DF transport motor comes on to feed the original from the original tray.

$$x_2 = (\text{original length} / \text{original speed}) + 2,000 \text{ ms}$$

JAM 3: If there is no original at the registration sensor when scanning is started, even though the sensor had already turned on.

JAM 4: The current original is stopped after the registration sensor detects its leading edge, but the previous original is still at the scanning position.

JAM 5: If the original stopped at the stamp position is removed.

JAM 6: If the cover is opened or the ADF is lifted up while the ADF is in operation.

JAM 7: If the DF gate signal (indicating that the original is now in the correct position for scanning) is not asserted when the original trailing edge passes the DF exposure glass.
JAM 7 occurs when the original is pulled out while it is being scanned.

1.7 OVERALL ELECTRICAL CIRCUIT

The DF CPU controls the DF feed motor, DF feed clutch, DF pick-up solenoid, and stamp solenoid. The DF CPU also monitors all sensors and provides updated status when prompted at regular intervals by the mainframe, which may then take action based on this information. The DF/mainframe connection is checked automatically immediately after the mainframe is powered on.

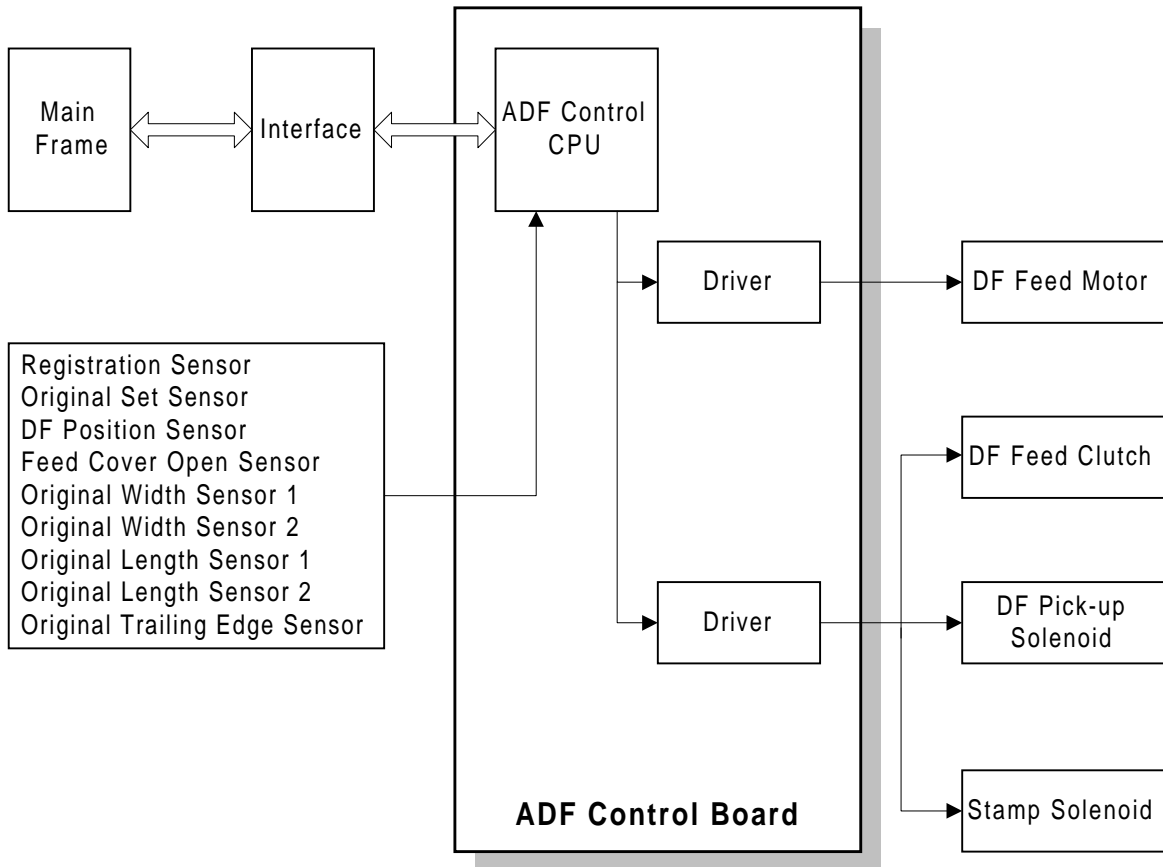

1.8 FREE RUN

You can use DIP switch 100 (on the DF control board) to carry out a one-sided free run.

Bits				
1	OFF	ON	OFF	ON
2	OFF	OFF	ON	ON
Mode	Normal	FR	FR	FR

FR: Free run

Procedure

1. Set bit 1 and/or bit 2 on SW100 (on the DF control board) to ON.
2. Set originals on the original table.
3. The free run starts automatically after about 2 seconds.
4. To stop the run, set SW100 bits 1 and 2 back to OFF. To ensure that the system correctly resets, turn power off and then back on.

Free Run Process

1. Set originals on the DF table.
2. The first original sheet feeds into the DF.
3. The sensor detects the original.
4. The DF outputs the original to the exit tray.
5. Steps 2 through 4 repeat for each subsequent original sheet. When all originals have been fed, the DF stops and waits for more.

3. REPLACEMENT AND ADJUSTMENT

3.1 EXTERIOR COVERS

3.1.1 REAR COVER

1. Lift the DF.
2. Unhook the three latches [A] in the order marked on the DF body.
3. Close the DF.
4. Open the DF feed cover [B].
5. Rear cover [C] (🔧 x 1)

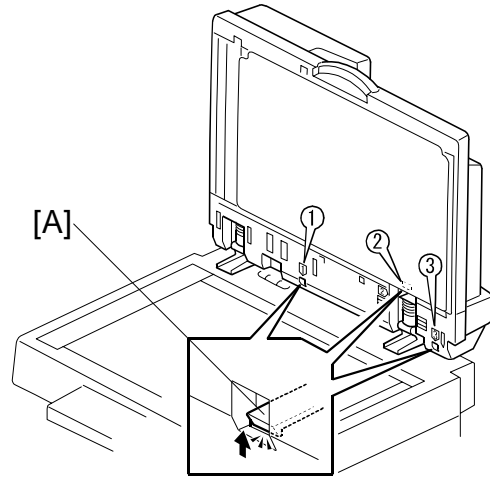

1.1.2 ORIGINAL TABLE

1. Rear cover (👉 3.1.1)
2. Original table [D] (🔧 x 2, 📐 x 2)

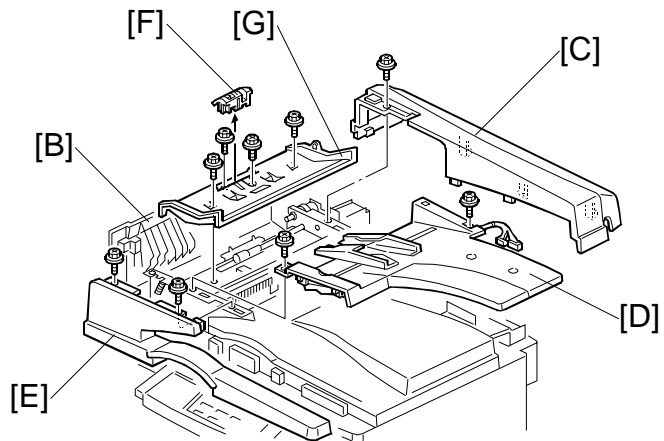

1.1.3 FRONT COVER

1. Open the DF feed cover [B].
2. Original table. (👉 1.1.2)
3. Front cover [E] (🔧 x 2)

1.1.4 ORIGINAL ENTRANCE GUIDE

1. Feed unit (👉 1.2)
2. Original table (👉 1.1.2)
3. Roller cover [F]
4. Original entrance guide [G] (🔧 x 4)

1.1.5 DF FEED COVER

1. Rear cover (☛ 3.1.1)
2. Original table (☛ 1.1.2)
3. Front cover (☛ 1.1.3)
4. Clip [A]
5. Strap [B] (☞ x 1)
6. DF feed cover [C] (☛ x 2)

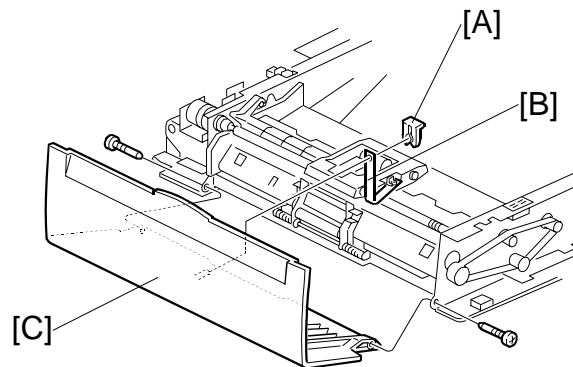

1.2 FEED UNIT

1. Open the DF feed cover [D] and detach the strap [E] (☞ x 1).
2. Raise the front guide flap [F] to about a 45-degree angle, and push the feed unit [G] into the spring so that it comes free.

NOTE: 1) The feed unit comes off very easily if you first lift flap [H] to about a 45-degree angle.

2) When reinstalling, be sure that the lever [I] is above the pin [J].

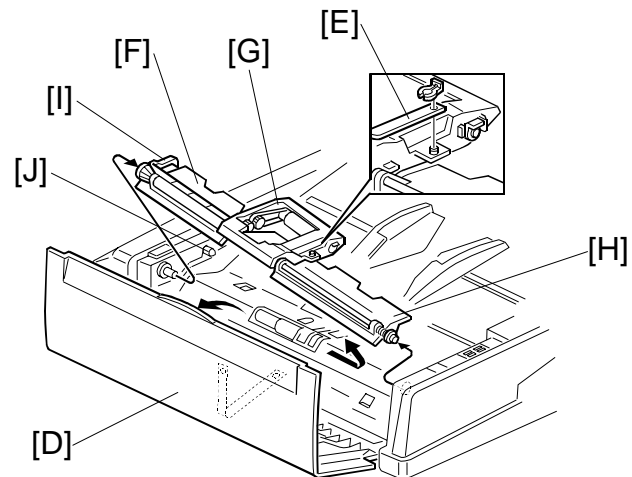

1.3 SEPARATION ROLLER

1. Feed unit (☛ 1.2)
2. Roller cover [K]
3. Separation roller [L] (☞ x 1).

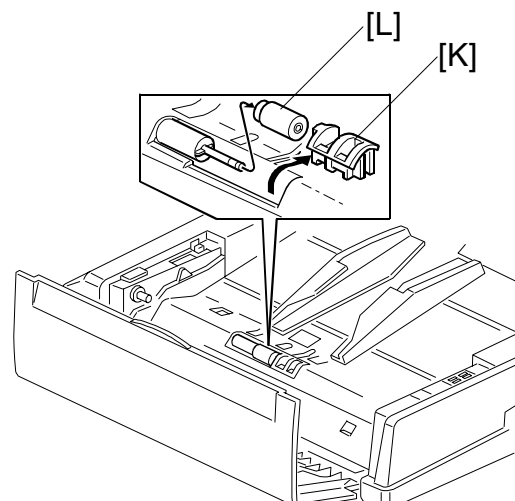

PICK-UP ROLLER

1.4 PICK-UP ROLLER

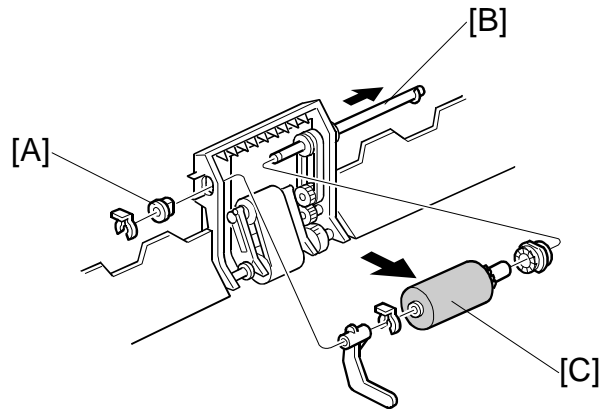

1. Feed unit (☛ 1.2)
2. Remove 2 clip rings and 1 bushing [A]
3. Pull the shaft [B] part way out at the gear end, so that the pick-up roller [C] can be taken off.

1.5 FEED BELT

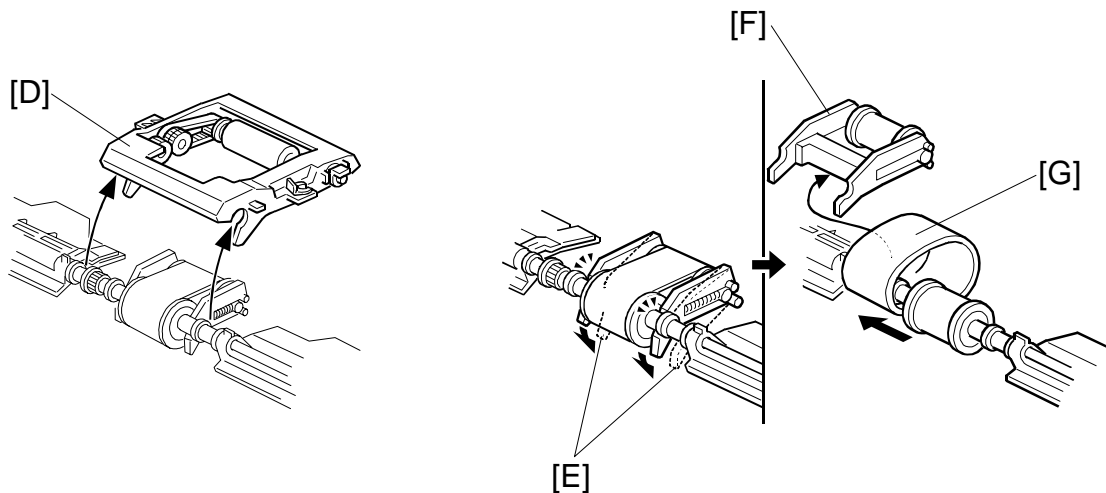

1. Feed unit (☛ 1.2)
2. Pick-up roller housing [D]
3. Push down on the lower wings [E] of the tensioning piece [F], so that the tensioning piece comes free of the shaft.
4. Take the tensioning piece out, and then remove the belt [G].

1.6 ORIGINAL SENSORS (WIDTH, LENGTH, TRAILING EDGE)

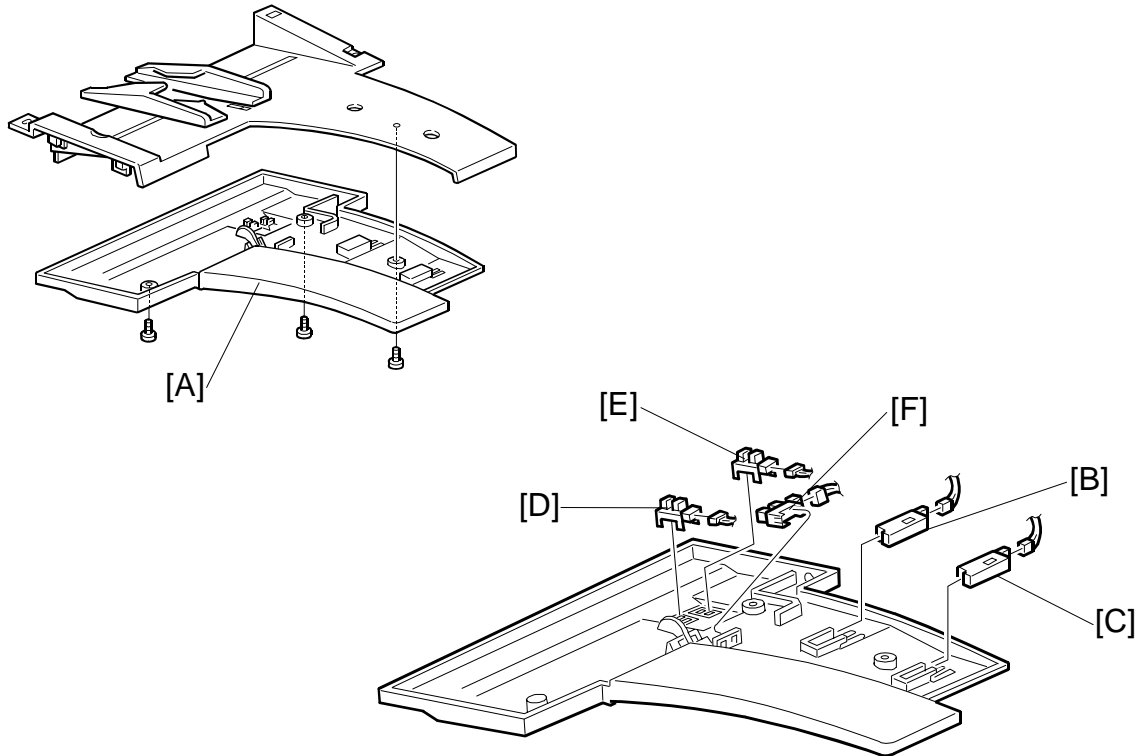

1. Original table (☛ 1.1.2)
2. Sensor platform [A] (☛ x 3).
3. Length sensors [B], [C] (☛ x 1 on each sensor)
NOTE: Replace both sensors at the same time, together with the wiring and connectors.
4. Width sensors [D], [E], and trailing edge sensor [F] (☛ x 1 on each sensor)
NOTE: Replace all three sensors at the same time, together with the wiring and connectors.

1.7 ORIGINAL SET SENSOR

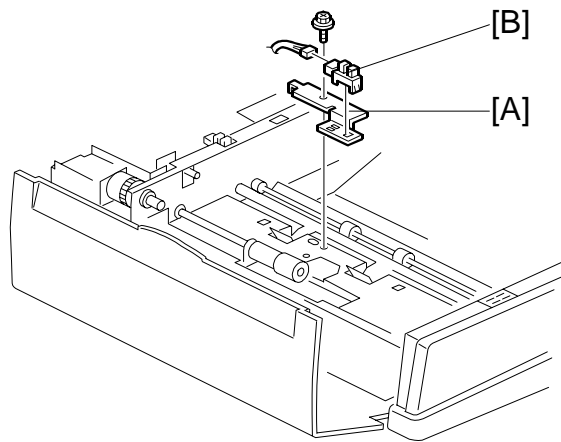

1. Original entrance guide (☛ 1.1.4)
2. Sensor bracket [A] (🔩 x 1)
3. Original set sensor [B] (🔌 x 1)

1.8 TRANSPORT MOTOR

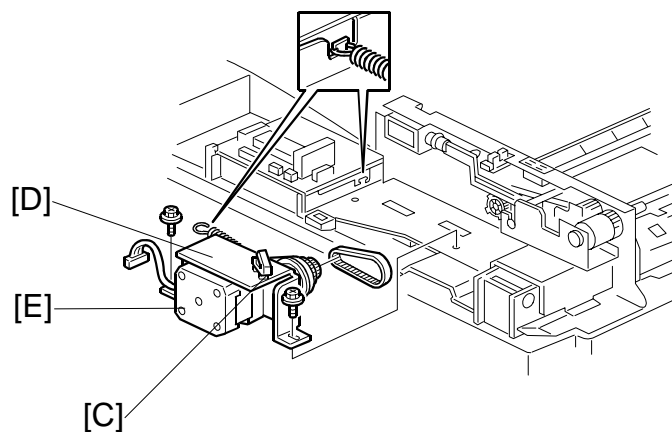

1. Rear cover (☛ 3.1.1)
2. Open the wire clamp [C] at the top of the motor bracket [D].
3. Motor bracket [D] (🔩 x 2 , 1 spring)
NOTE: Unhook the spring at the board side.
4. Transport motor [E] (🔩 x 2, 🔌 x 1)

1.9 DF COVER OPEN SENSOR/FEED CLUTCH/ROM/DF DRIVE BOARD

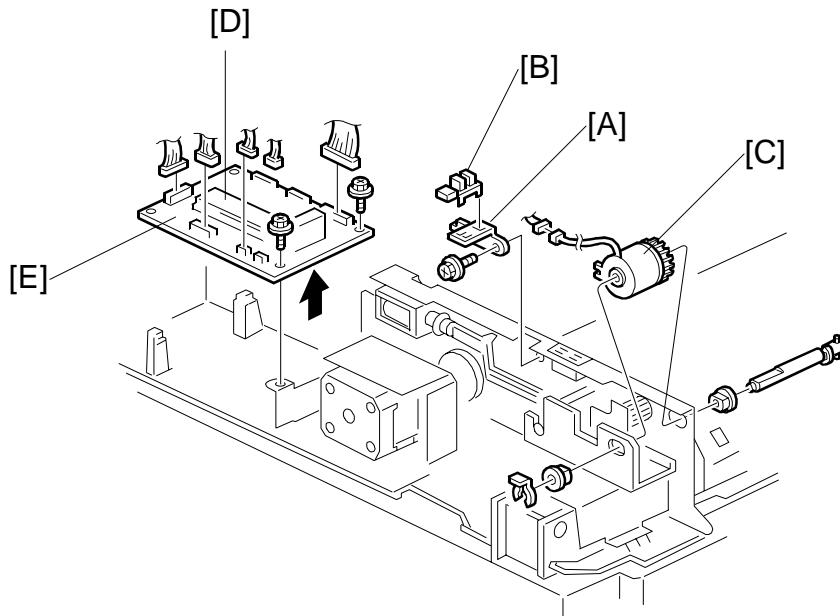

Exterior

1. Rear cover (☛ 3.1.1)

Feed Cover Open Sensor

2. Sensor bracket [A] (☛ x 1)
3. Feed cover open sensor [B] (☛ x 1)

Feed Clutch

2. Feed unit (☛ 1.2)
3. Feed clutch [C] (☛ x 1, 1 bushing, ☛ x 1).
NOTE: Pull the shaft inward until the clutch can be removed.

ROM

2. Replace the ROM [D] on the DF drive board.

DF Drive Board

2. DF drive board [E] (☛ x 3, all connectors)

REGISTRATION SENSOR

1.10 REGISTRATION SENSOR

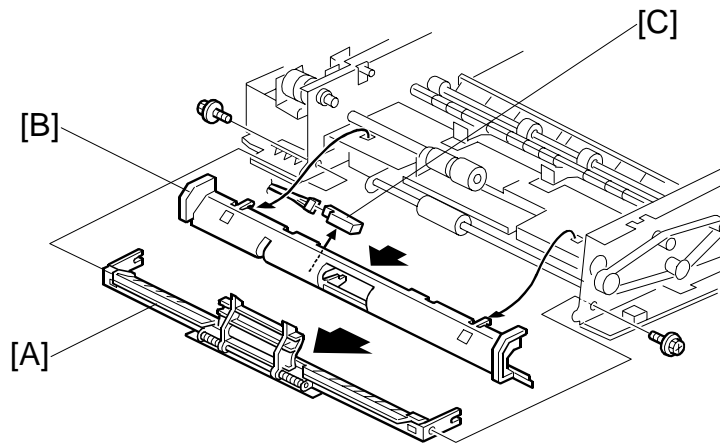

1. DF feed cover (☛ 1.1.5)
2. Original entrance guide (☛ 1.1.4)
3. Outer turn guide [A] (🔩 x 2)
4. Pop out the inner turn guide [B], and remove the registration sensor [C] (🔩 x 1)

1.11 PICK-UP SOLENOID

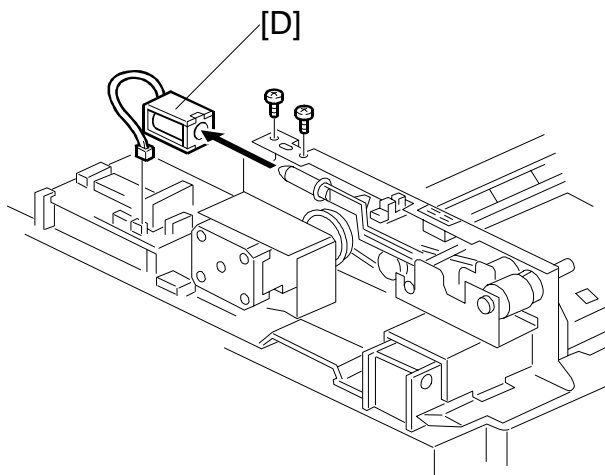

1. Rear cover (☛ 3.1.1)
2. Pick-up solenoid [D] (🔩 x 2, 📌 x 1)

1.12 STAMP SOLENOID

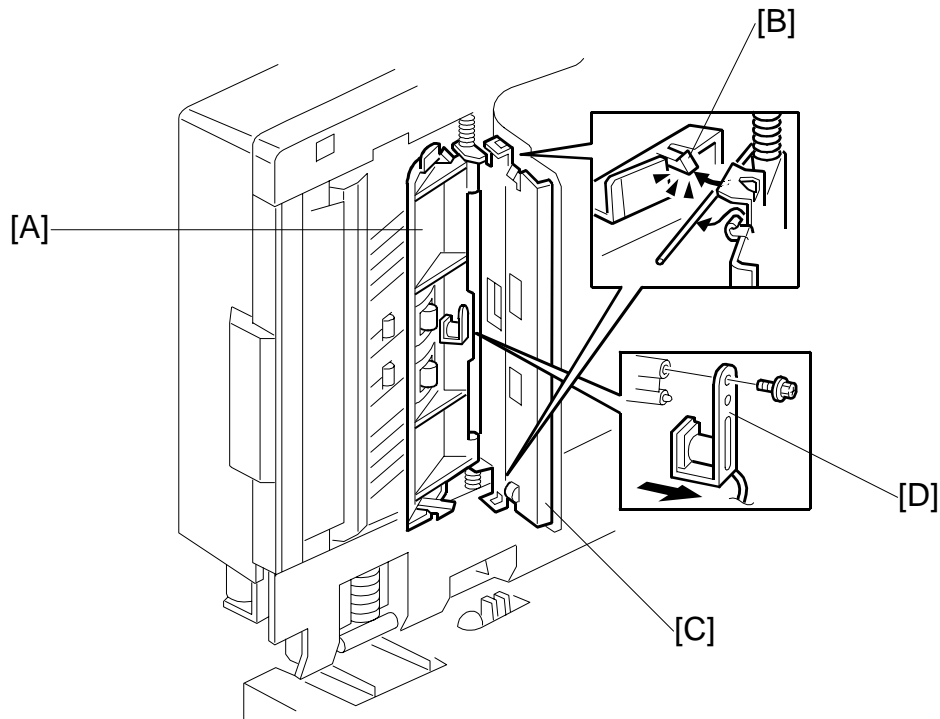

1. Rear cover (☛ 3.1.1)
2. Disconnect the stamp solenoid connector.
NOTE: Pull out the small connector piece from the large connector. (The large connector itself cannot fit through the hole in the frame.)
3. Lift the ADF upright and pull open the exit guide [A]. Release the front and rear hooks [B] and open the cover [C].
4. Remove the stamp solenoid [D] (⚙ x 1), and pull it out together with the wire.

PAPER TRAY UNIT B384

1. OVERALL MACHINE INFORMATION

1.1 MECHANICAL COMPONENT LAYOUT

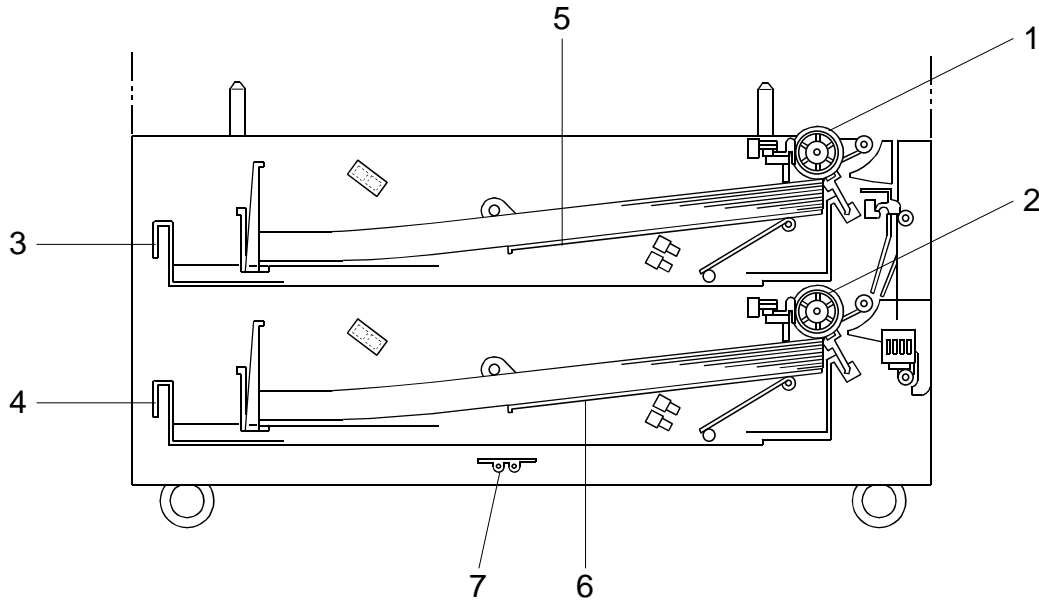

1. Upper Paper Feed Roller
2. Lower Paper Feed Roller
3. Upper Tray
4. Lower Tray

5. Upper Bottom Plate
6. Lower Bottom Plate
7. Optional Tray Heater

1.2 ELECTRICAL COMPONENT LAYOUT

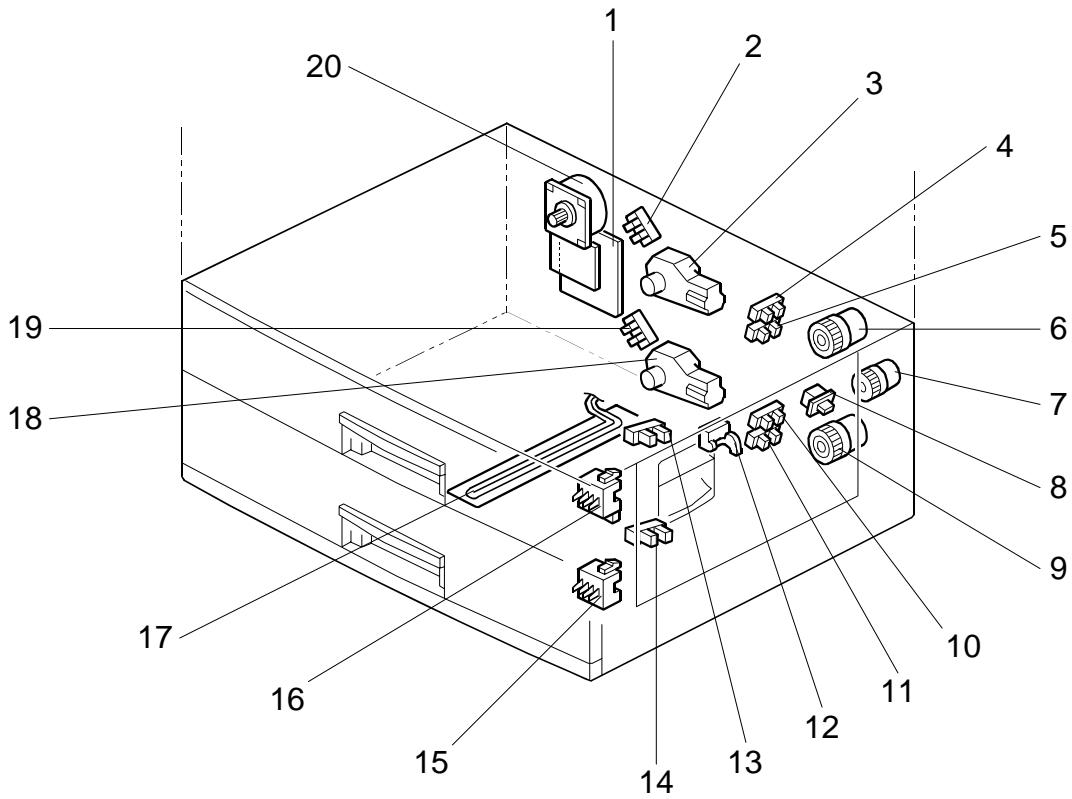

- | | |
|---------------------------------|---------------------------------|
| 1. Tray Main Board | 11. Lower Paper Height 1 Sensor |
| 2. Upper Lift Sensor | 12. Vertical Transport Sensor |
| 3. Upper Lift Motor | 13. Upper Paper End Sensor |
| 4. Upper Paper Height 2 Sensor | 14. Lower Paper End Sensor |
| 5. Upper Paper Height 1 Sensor | 15. Lower Paper Size Switch |
| 6. Upper Paper Feed Clutch | 16. Upper Paper Size Switch |
| 7. Relay Clutch | 17. Optional Tray Heater |
| 8. Tray Cover Switch | 18. Lower Lift Motor |
| 9. Lower Paper Feed Clutch | 19. Lower Lift Sensor |
| 10. Lower Paper Height 2 Sensor | 20. Tray Motor |

1.3 DRIVE LAYOUT

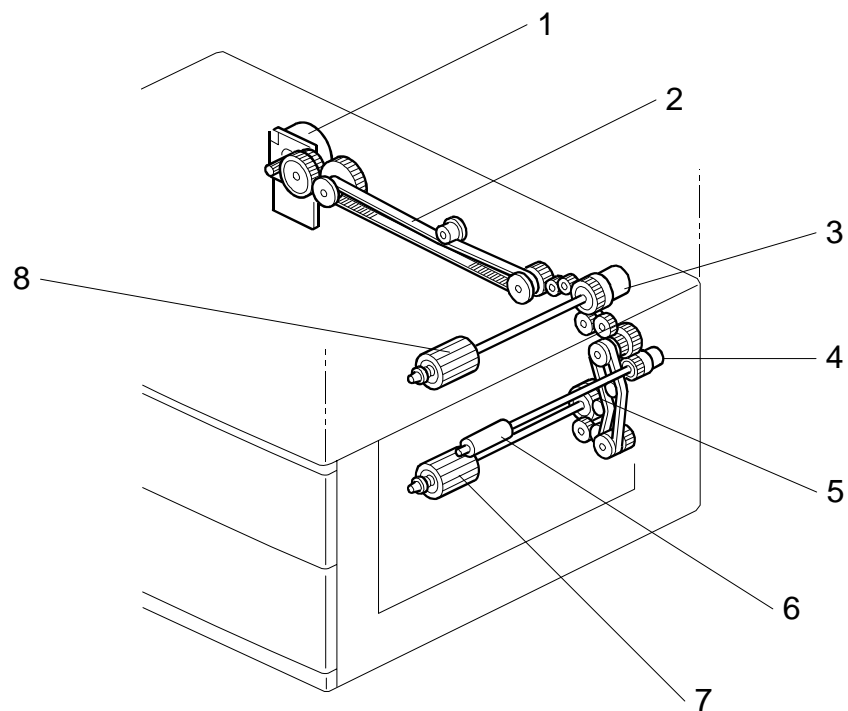

- | | |
|----------------------------|----------------------------|
| 1. Tray Motor | 5. Lower Paper Feed Clutch |
| 2. Drive Belt | 6. Relay Roller |
| 3. Upper Paper Feed Clutch | 7. Lower Paper Feed Roller |
| 4. Relay Clutch | 8. Upper Paper Feed Roller |

2. DETAILED DESCRIPTIONS

2.1 PAPER FEED AND SEPARATION MECHANISM

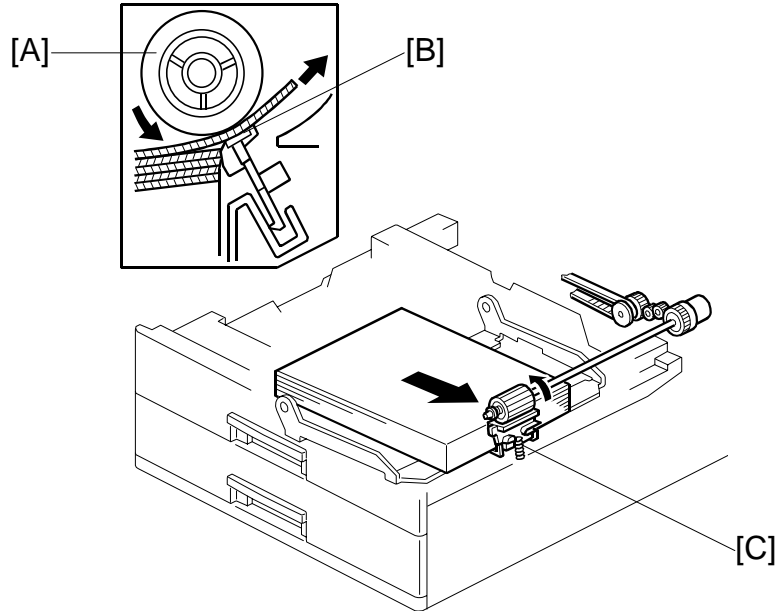

Each paper tray holds 500 sheets. The paper feed roller [A] drives the top sheet of paper from the paper tray to the copier/printer. The friction pad [B] allows only one sheet to feed at a time. The friction pad applies pressure to the feed roller with a spring [C].

2.2 PAPER LIFT MECHANISM

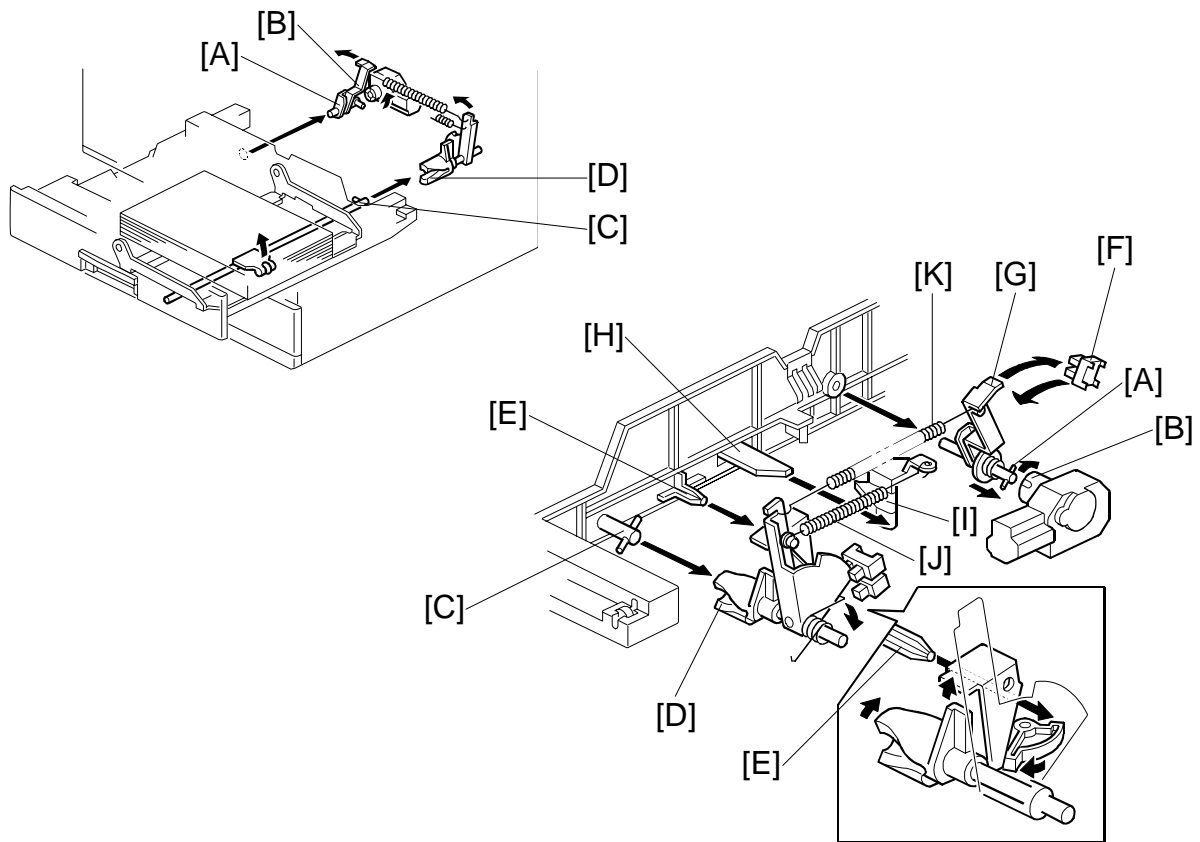

The paper size switch detects when the tray is pushed in.

When the paper tray is pushed into the machine, the pin [A] for the lift motor pressure shaft engages the lift motor coupling [B] and the pin [C] for the bottom plate lift shaft in the tray engages the bottom plate pressure lever coupling [D]. The pin [E] on the rear of the tray pushes the lock lever so that the lift motor can lift the bottom plate pressure lever.

The lift motor turns on, and turns clockwise as viewed on the lower diagram. The main pressure spring [K] pulls the bottom plate pressure lever, and this lifts the tray bottom plate.

When the top of the stack touches the feed roller, the motor cannot pull up the plate any more, so it pulls the actuator [G] into the lift sensor [F].

The pressure of the feed roller on the paper is now too high, so the lift motor reverses to reduce this pressure. It reverses for 300 ms or 600 ms, depending on the paper size. For smaller paper, it reverses the larger amount (600 ms) to reduce the pressure more.

PAPER LIFT MECHANISM

For A4-SEF paper or wider, a projection [H] on the side fence engages the secondary pressure spring [J] through a lever [I]. Then, the secondary pressure spring [J] applies paper feed pressure in addition to the main pressure spring [K], to ensure that extra pressure is applied to wider paper.

When the paper tray is pulled out, the pins [A, C] disengage from the couplings [B, D], and the bottom plate drops. To make it easier to push the tray in, the lift motor rotates backwards 1.7 seconds to return the bottom plate pressure lever coupling [D] to the original position.

The lift motor on timing can be adjusted with SP mode, to change the pressure from the main pressure spring.

- SP1-908-1 (1st tray), 1-908-2 (2nd tray)
- Default: 0
- Increase the pressure: +1, +2
- Decrease the pressure: -1, -2

If the pressure is too strong, the sheet of paper may not be fed smoothly, and if it is too weak, more than one sheet of paper may be fed at a time.

The pressure depends on the paper size.

2.3 PAPER END DETECTION

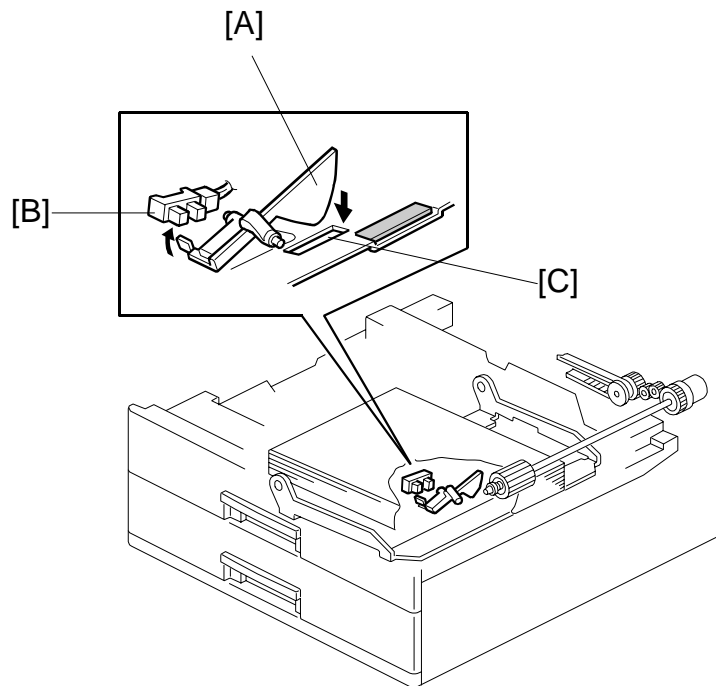

If there is some paper in the paper tray, the paper stack raises the paper end feeler [A] and the paper end sensor [B] is deactivated.

When the paper tray runs out of paper, the paper end feeler drops into the cutout [C] in the tray bottom plate and the paper end sensor is activated.

When the paper tray is drawn out with no paper in the tray, the shape of the paper end feeler causes it to lift up.

2.4 PAPER HEIGHT DETECTION

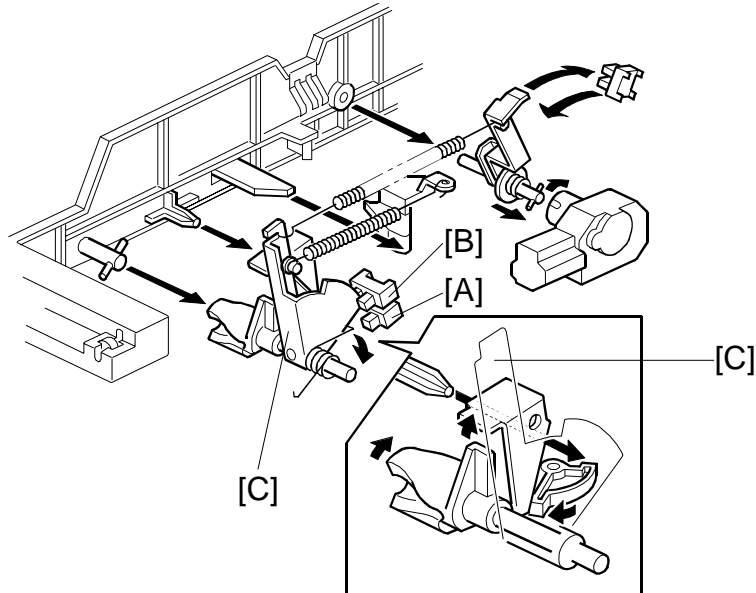

The amount of paper in the tray is detected by the combination of on/off signals from two paper height sensors [A] and [B].

When the amount of paper decreases, the bottom plate pressure lever [C] moves the actuator up.

The following combination of sensor signals is sent to the copier/printer.

Amount of Paper	Paper Height Sensor 1	Paper Height Sensor 2
Near End	OFF	ON
30%	ON	ON
70%	ON	OFF
100%	OFF	OFF

When the tray contains paper of a small width, the paper feed pressure may become too low when the thickness of the remaining stack of paper has decreased. The lift motor rotates forward 300 ms after the sensor detects a certain amount of paper remaining in the tray to increase paper feed pressure, simulating the pressure generated by a full tray.

PAPER SIZE DETECTION

Size	SW	1	2	3	4
A3, F (8 1/2" x 13")		○	○	○	○
A4 short-edge		●	●	○	○
A4 long-edge		●	●	○	●
A5 long-edge 11" x 17"		○	○	●	●
B4, 8 1/2" x 14"		●	○	●	○
B5 long-edge, 8 1/2" x 11"		●	○	○	○
B5 short-edge, 11" x 8 1/2"		○	●	●	●
* (Asterisk)		○	●	○	●

○: ON (Pushed)
 ●: OFF (Not pushed)

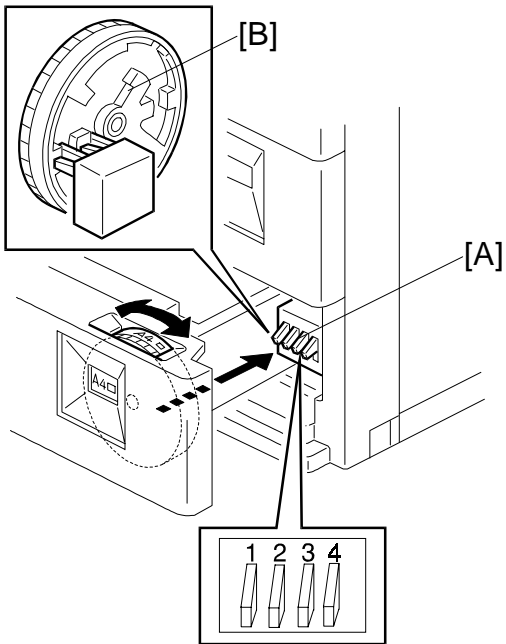

There are four paper size microswitches [A] on the front right plate of the paper tray unit. The switches are actuated by a paper size actuator [B] behind the paper size indicator plate, which is on the front right of the tray.

Each paper size has its own actuator, with a unique combination of notches. To determine which size has been installed, the CPU reads which microswitches the actuator has switched off.

The CPU disables paper feed from a tray if the paper size cannot be detected. If the paper size actuator is broken, or if there is no tray installed, the Add Paper indicator will light.

When the paper size actuator is at the "*" mark, the paper tray can be set up to accommodate one of a wider range of paper sizes by using user tools. If the paper size for this position is changed without changing the user tool setting, a paper jam will result.

2.5 SIDE AND END FENCES

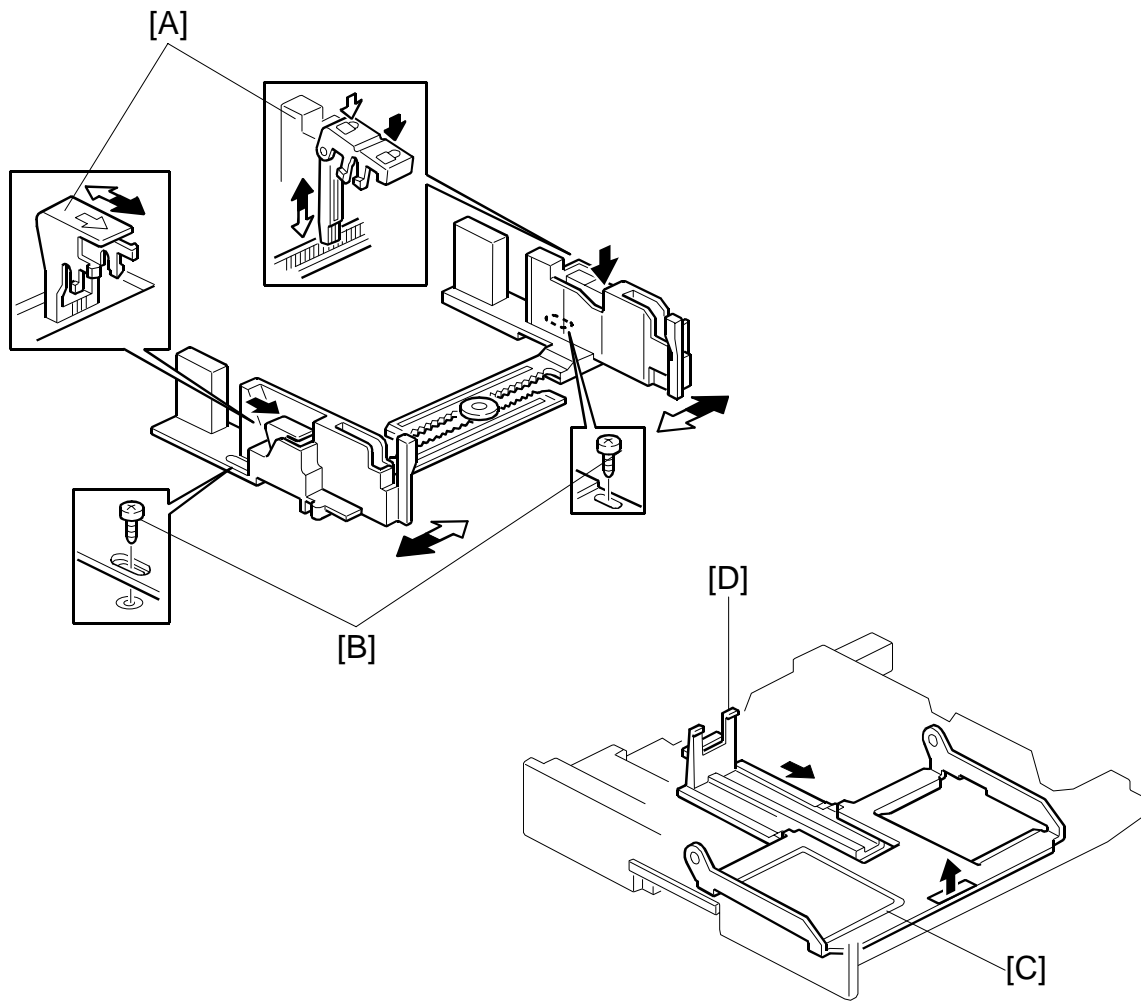

Side Fences

If the tray is full of paper and it is pushed in strongly, the fences may deform or bend. This may cause the paper to skew or the side-to-side registration to be incorrect. To correct this, each side fence has a stopper [A] attached to it. Each side fence can be secured with a screw [B], for customers who do not want to change the paper size.

End Fence

As the amount of paper in the tray decreases, the bottom plate [C] lifts up gradually. The end fence [D] is connected to the bottom plate. When the tray bottom plate rises, the end fence moves forward and pushes the back of the paper stack to keep it squared up.

3. REPLACEMENT AND ADJUSTMENT

3.1 FEED ROLLER REPLACEMENT

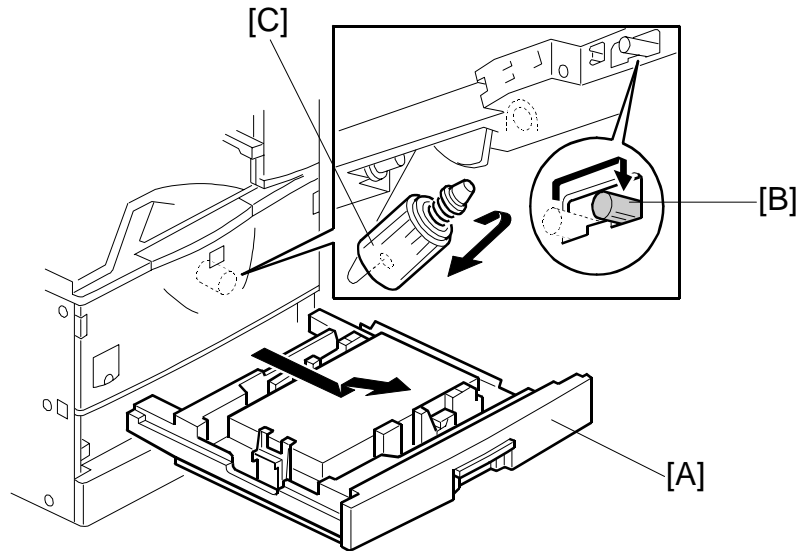

1. [A] Paper tray
2. Move the release lever [B] to the front.
3. Pull the feed roller [C] to the operation side and remove it.

TRAY MAIN BOARD REPLACEMENT

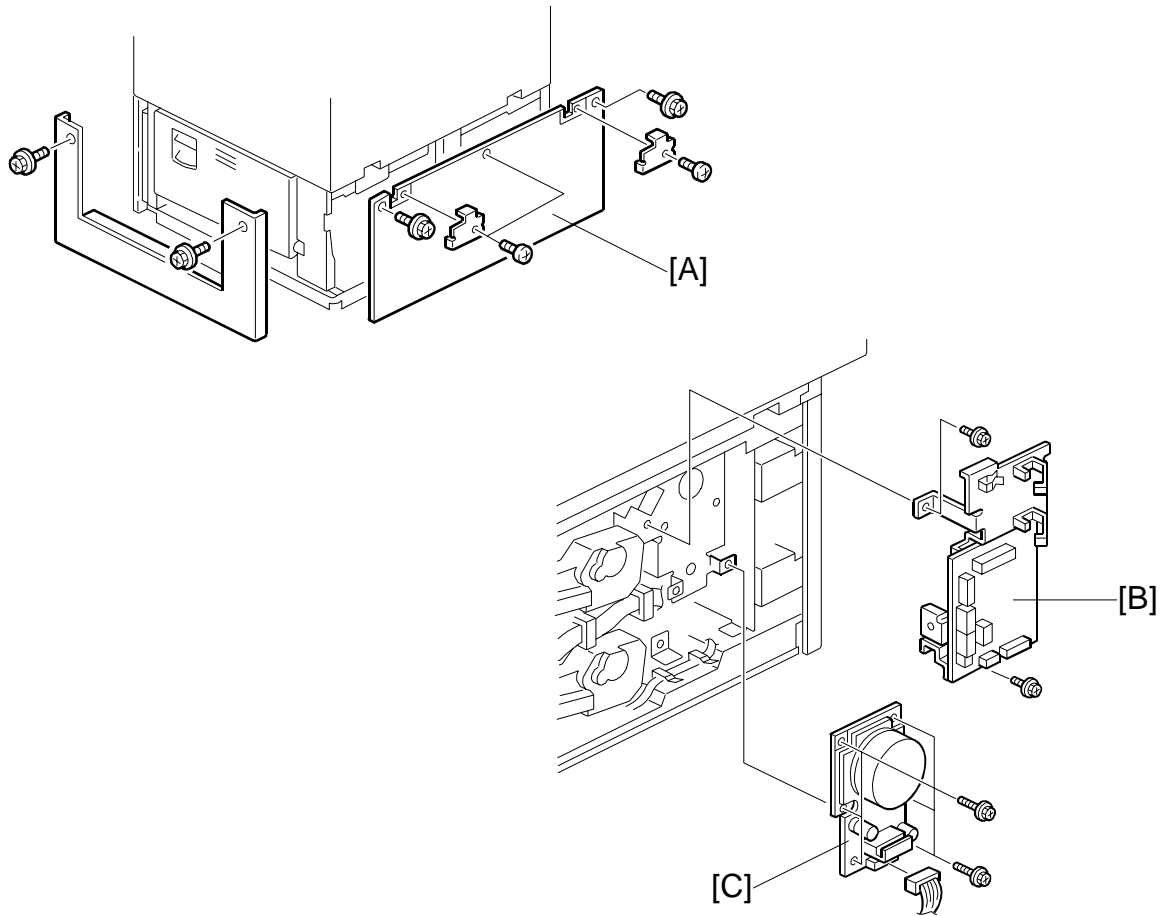

3.2 TRAY MAIN BOARD REPLACEMENT

1. [A] Rear cover (🔩 x 5)
2. [B] Tray main board (🔩 x 4, 📌 x 8)

3.3 TRAY MOTOR REPLACEMENT

1. Rear cover (🔩 x 5)
2. Disconnect 8 connectors from the tray main board [B].
3. Tray main board with the bracket (🔩 x 2)
4. [C] Tray motor (🔩 x 6, 📌 x 1)

3.4 RELAY CLUTCH REPLACEMENT

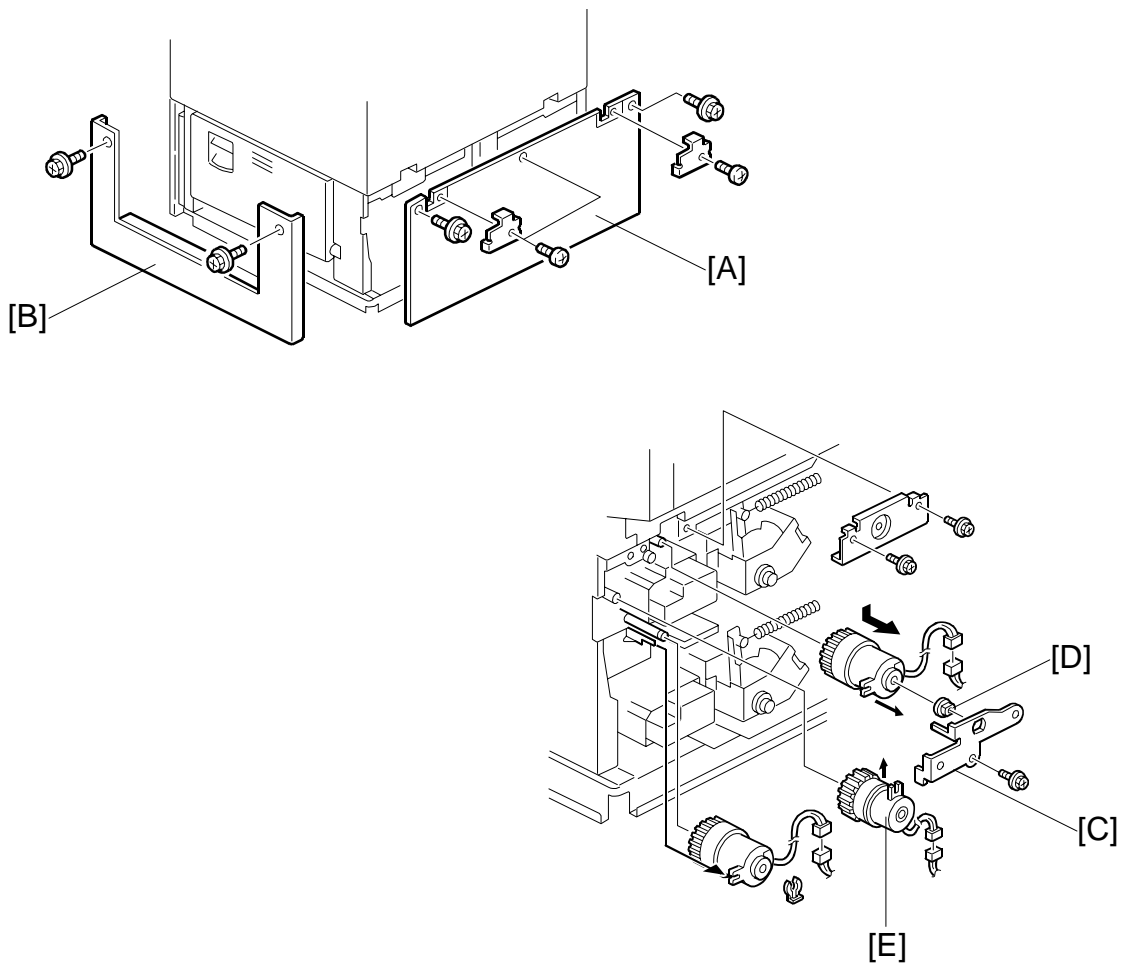

1. [A] Rear cover (🔩 x 5)
2. [B] Right cover (🔩 x 2)
3. [C] Stopper bracket (🔩 x 1)
4. [D] Bushing
5. [E] Relay clutch (🔩 x 1)

3.5 UPPER PAPER FEED CLUTCH REPLACEMENT

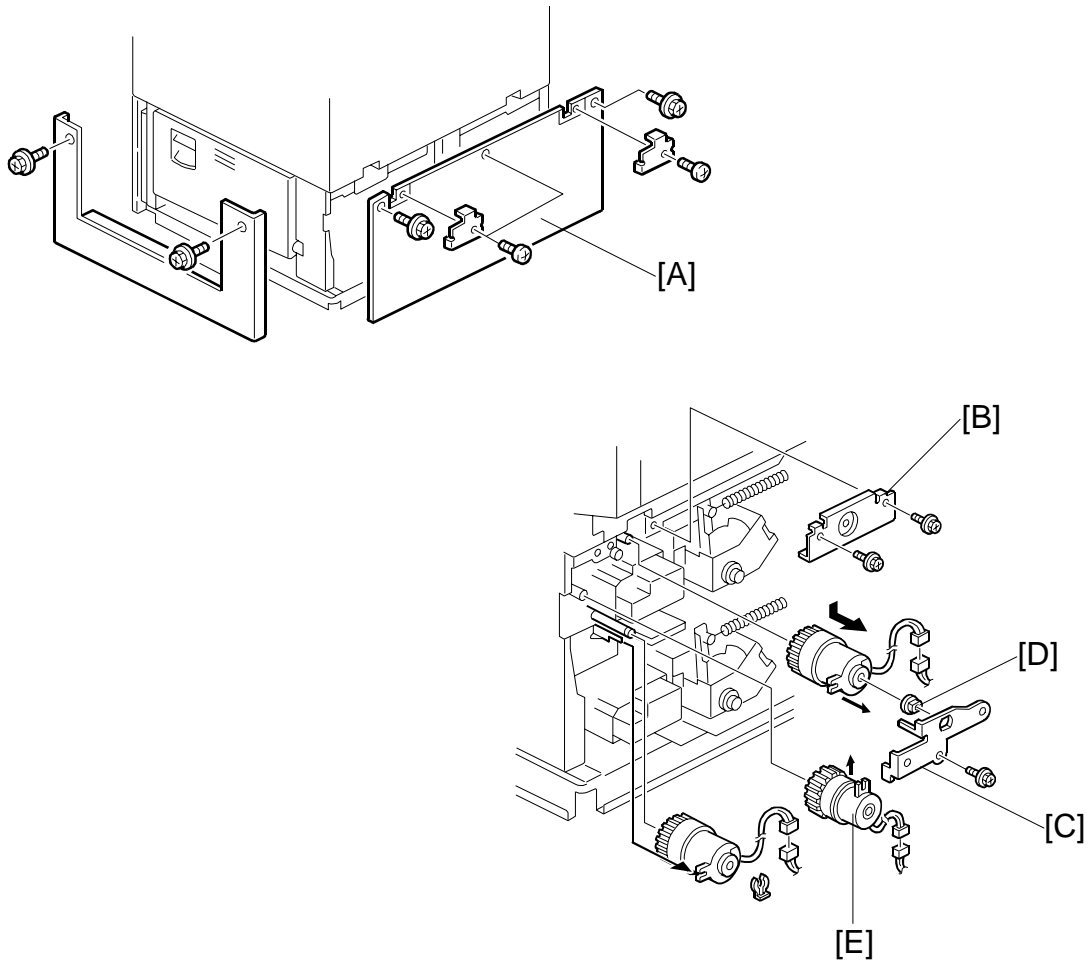

1. [A] Rear cover (🔩 x 5)
2. [B] Bracket (🔩 x 2)
3. [C] Stopper bracket (🔩 x 2)
4. [D] Bushing
5. [E] Upper paper feed clutch (🔩 x 1)

3.6 LOWER PAPER FEED CLUTCH REPLACEMENT

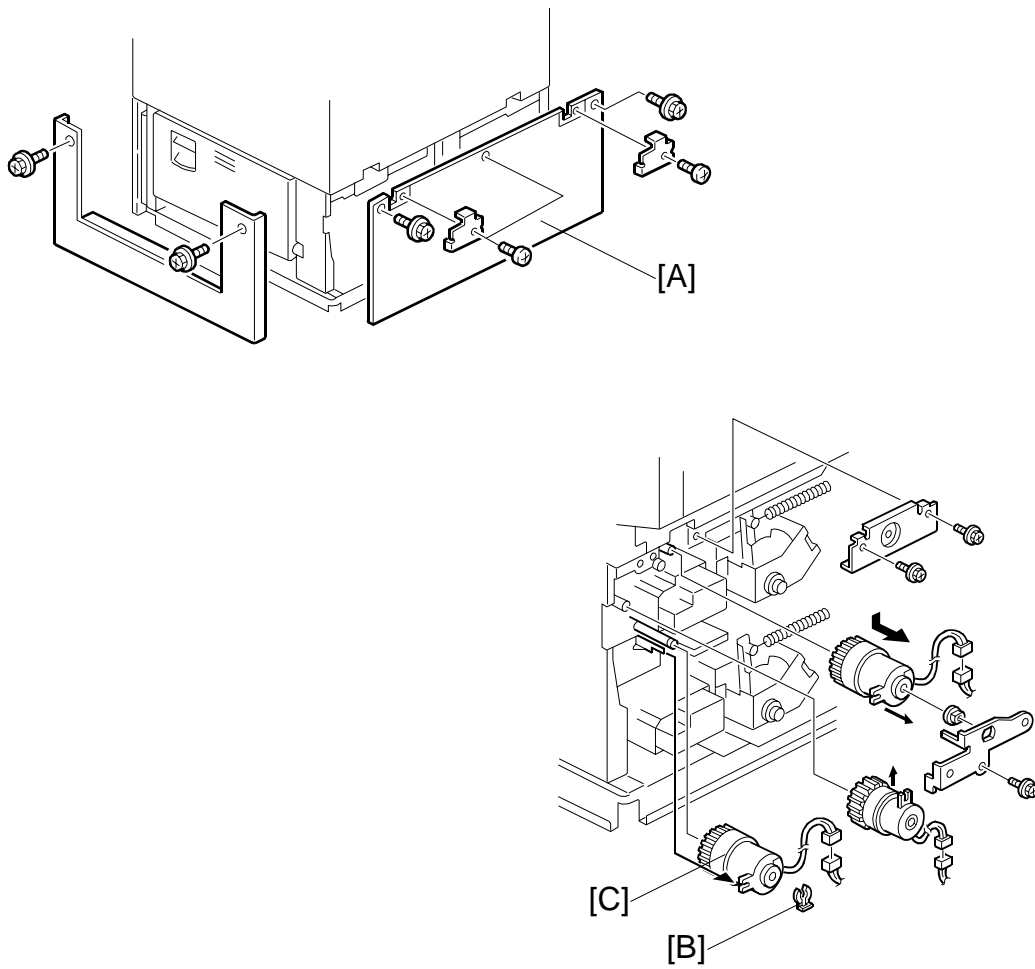

1. [A] Rear cover (ϕ x 5)
2. [B] Snap ring
3. [C] Lower paper feed clutch

3.7 LIFT MOTOR REPLACEMENT

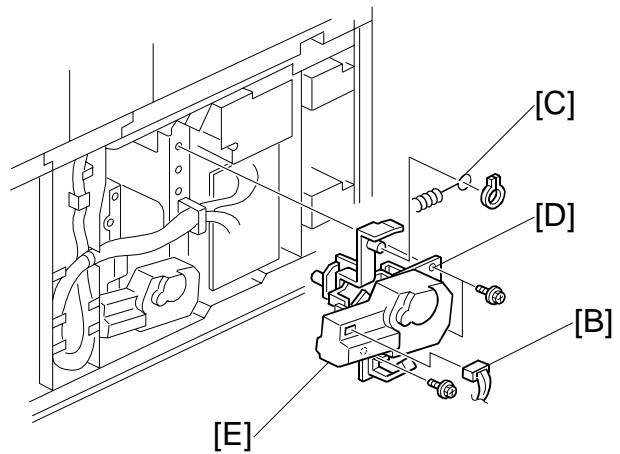
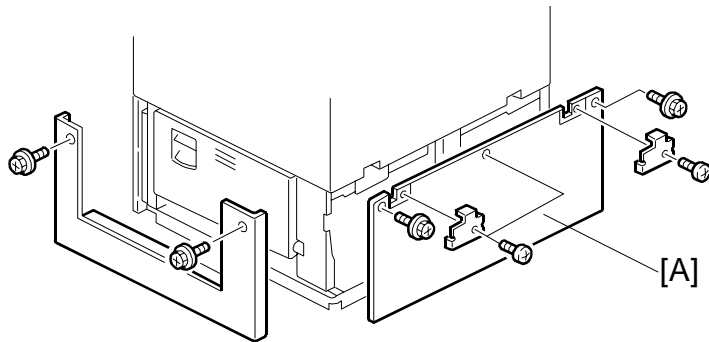

1. Pull out the paper tray.
2. [A] Rear cover (🔩 x 5)
3. [B] 2P connector
4. [C] Spring
5. [D] Lift motor unit (🔩 x 3)
6. [E] Lift motor (🔩 x 3)

3.8 PAPER END SENSOR REPLACEMENT

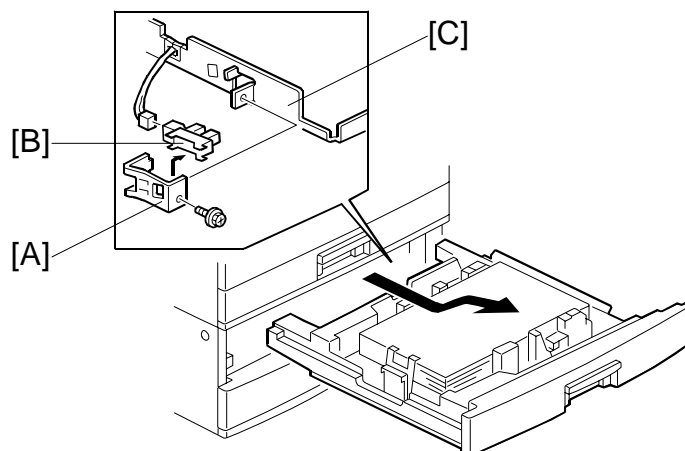

1. Paper tray
2. [A] Paper end sensor bracket (🔩 x 1, 📏 x 1)
3. [B] Paper end sensor

NOTE: After replacing the sensor, pull the sensor cable towards the right side of the frame [C] so that it does not touch the paper in the tray.

3.9 VERTICAL TRANSPORT SENSOR REPLACEMENT

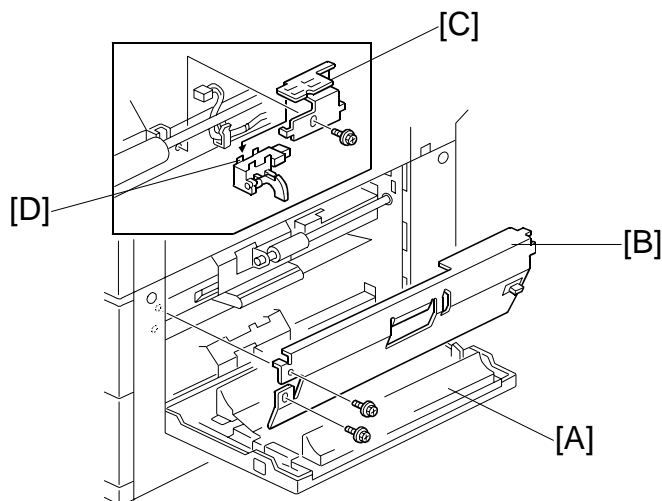

1. Open the right door [A].
2. [B] Right guide plate (🔩 x 2)
3. [C] Vertical transport sensor bracket (🔩 x 1, 📏 x 1)
4. [D] Vertical transport sensor

3.10 PAPER SIZE SWITCH REPLACEMENT

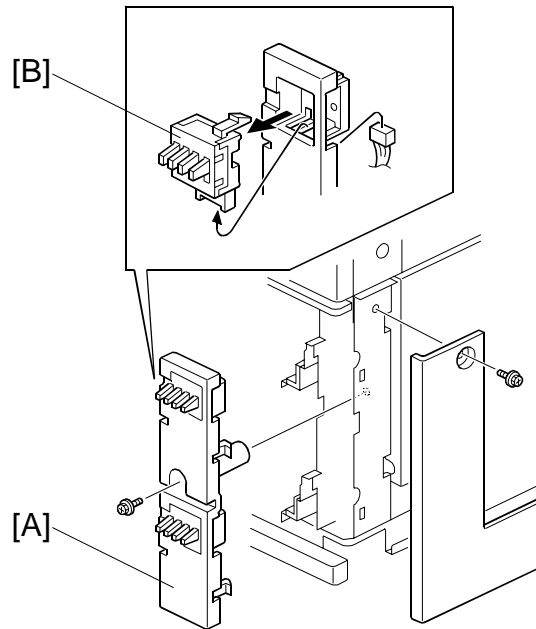

1. Upper and lower paper trays
2. [A] Inner cover (🔩 x 2)
3. [B] Paper size switch (📄 x 1)

PAPER TRAY UNIT B385

1. OVERALL MACHINE INFORMATION

1.1 MECHANICAL COMPONENT LAYOUT

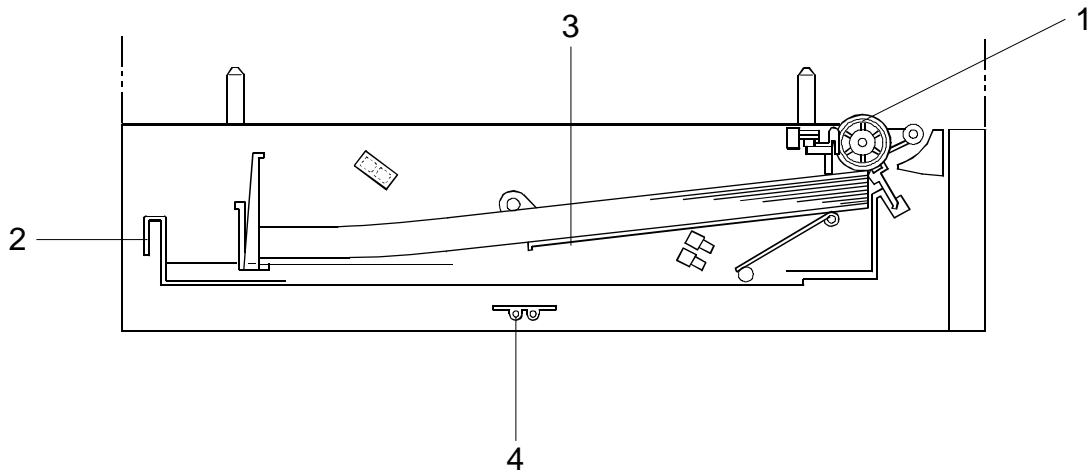

Paper Tray
Unit
B385

- 1. Paper Feed Roller
- 2. Tray

- 3. Bottom Plate
- 4. Optional Tray Heater

1.2 ELECTRICAL COMPONENT LAYOUT

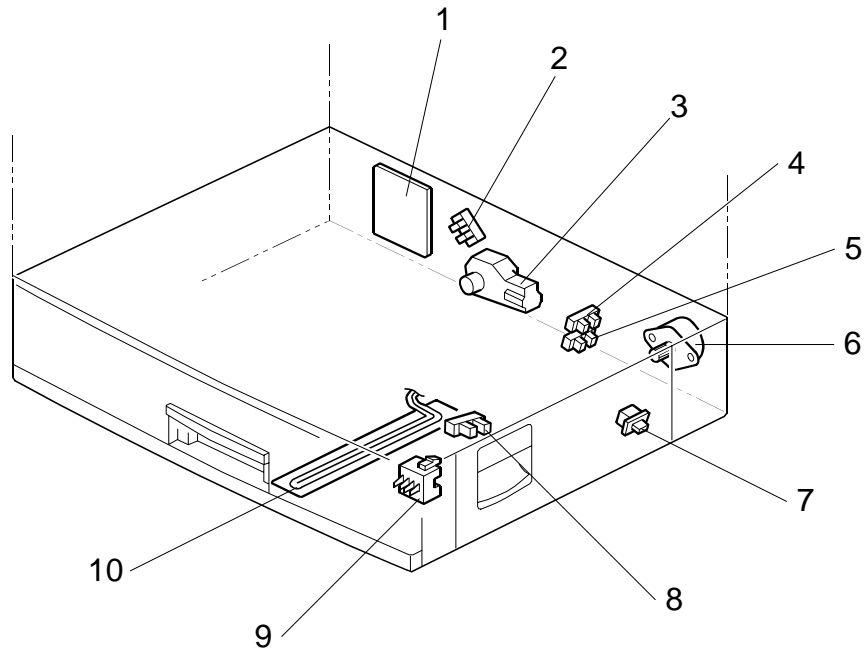

- | | |
|--------------------------|--------------------------|
| 1. Tray Main Board | 6. Paper Feed Motor |
| 2. Lift Sensor | 7. Tray Cover Switch |
| 3. Lift Motor | 8. Paper End Sensor |
| 4. Paper Height 2 Sensor | 9. Paper Size Switch |
| 5. Paper Height 1 Sensor | 10. Optional Tray Heater |

1.3 DRIVE LAYOUT

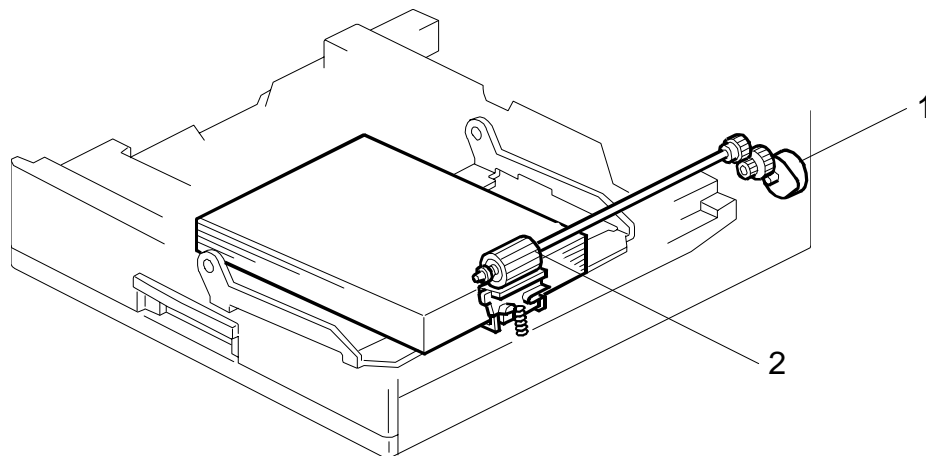

Paper Tray
Unit
B385

1. Paper Feed Motor

2. Paper Feed Roller

2. DETAILED DESCRIPTIONS

2.1 PAPER FEED AND SEPARATION

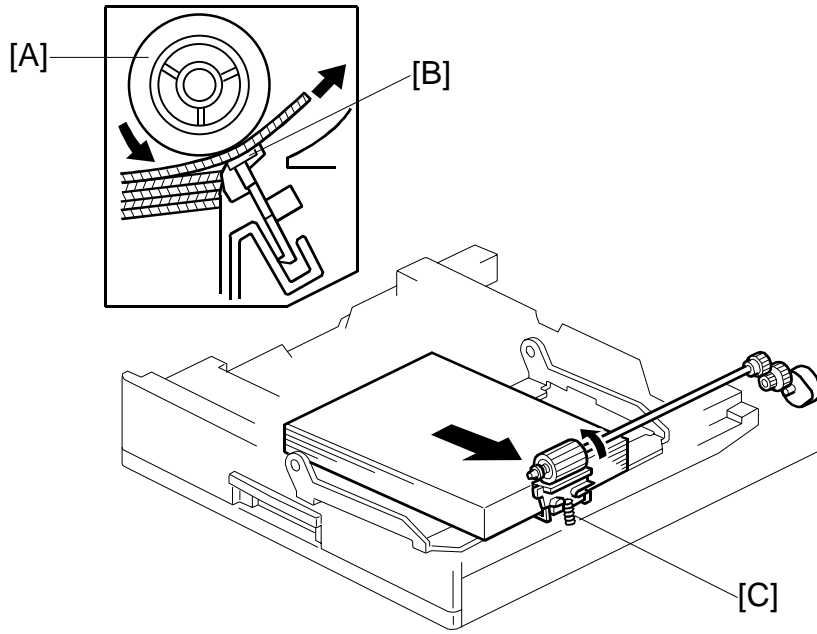

The paper tray holds 500 sheets. The paper feed roller [A] drives the top sheet of paper from the paper tray to the copier/printer. The friction pad [B] allows only one sheet to feed at a time. The friction pad applies pressure to the feed roller with a spring [C].

2.2 PAPER LIFT MECHANISM

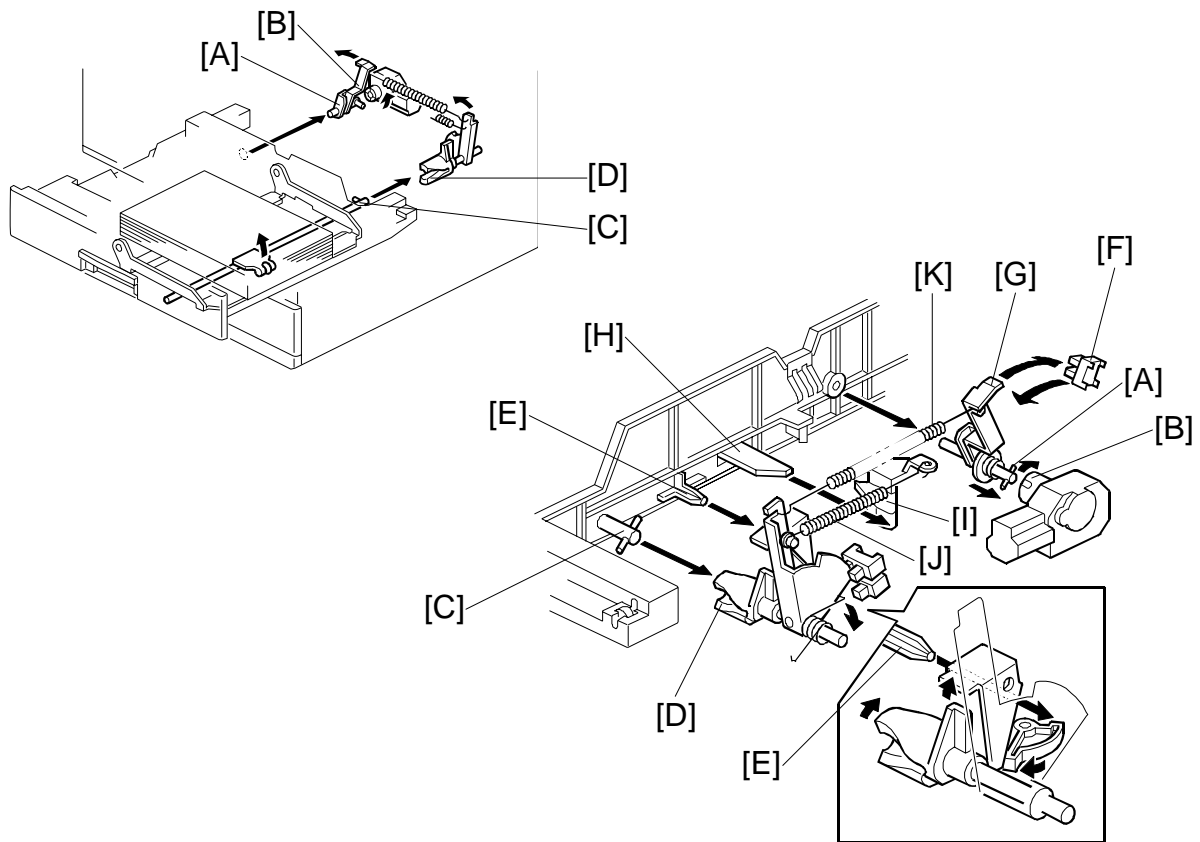

Paper Tray
Unit
B385

The paper size switch detects when the tray is pushed in.

When the paper tray is pushed into the machine, the pin [A] for the lift motor pressure shaft engages the lift motor coupling [B] and the pin [C] for the bottom plate lift shaft in the tray engages the bottom plate pressure lever coupling [D]. The pin [E] on the rear of the tray pushes the lock lever so that the lift motor can lift the bottom plate pressure lever.

The lift motor turns on, and turns clockwise as viewed on the lower diagram. The main pressure spring [K] pulls the bottom plate pressure lever, and this lifts the tray bottom plate.

When the top of the stack touches the feed roller, the motor cannot pull up the plate any more, so it pulls the actuator [G] into the lift sensor [F].

The pressure of the feed roller on the paper is now too high, so the lift motor reverses to reduce this pressure. It reverses for 300 ms or 600 ms, depending on the paper size. For smaller paper, it reverses the larger amount (600 ms) to reduce the pressure more.

PAPER LIFT MECHANISM

For A4-SEF paper or wider, a projection [H] on the side fence engages the secondary pressure spring [J] through a lever [I]. Then, the secondary pressure spring [J] applies paper feed pressure in addition to the main pressure spring [K], to ensure that extra pressure is applied to wider paper.

When the paper tray is pulled out, the pins [A, C] disengage from the couplings [B, D], and the bottom plate drops. To make it easier to push the tray in, the lift motor rotates backwards 1.7 seconds to return the bottom plate pressure lever coupling [D] to the original position.

The lift motor on timing can be adjusted with an SP mode, to change the pressure from the main pressure spring.

- SP1-908-1
- Default: 0
- Increase the pressure: +1, +2
- Decrease the pressure: -1, -2

If the pressure is too strong, the sheet of paper may not be fed smoothly, and if it is too weak, more than one sheet of paper may be fed at a time.

The pressure depends on the paper size.

2.3 PAPER END DETECTION

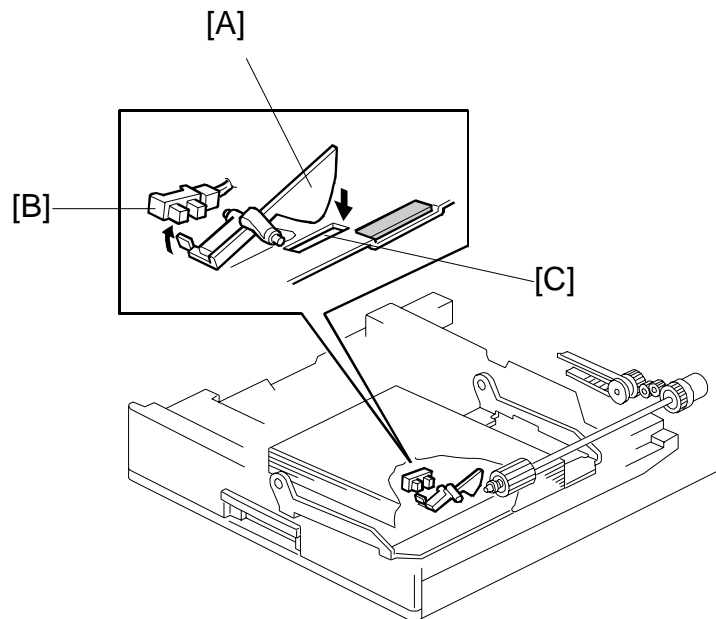

Paper Tray
Unit
B385

If there is some paper in the paper tray, the paper stack raises the paper end feeler [A] and the paper end sensor [B] is deactivated.

When the paper tray runs out of paper, the paper end feeler drops into the cutout [C] in the tray bottom plate and the paper end sensor is activated.

When the paper tray is drawn out with no paper in the tray, the shape of the paper end feeler causes it to lift up.

2.4 PAPER HEIGHT DETECTION

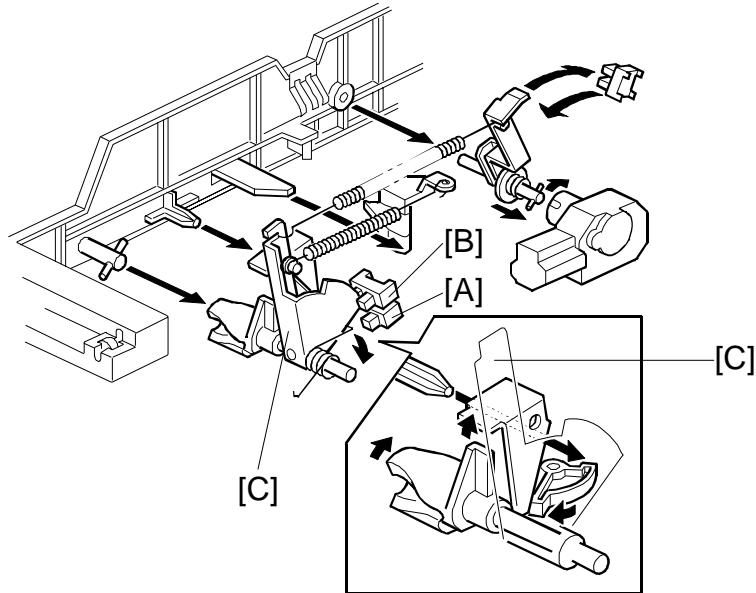

The amount of paper in the tray is detected by the combination of on/off signals from two paper height sensors [A] and [B].

When the amount of paper decreases, the bottom plate pressure lever [C] moves the actuator up.

The following combination of sensor signals is sent to the copier/printer.

Amount of Paper	Paper Height Sensor 1	Paper Height Sensor 2
Near End	OFF	ON
30%	ON	ON
70%	ON	OFF
100%	OFF	OFF

When the tray contains paper of a small width, the paper feed pressure may become too low when the thickness of the stack of remaining paper has decreased. The lift motor rotates forward 300 ms after the sensor detects a certain amount of paper remaining in the tray to increase paper feed pressure, simulating the pressure generated by a full tray.

2.5 PAPER SIZE DETECTION

Size	SW			
	1	2	3	4
A3, F (8 1/2" x 13")	○	○	○	○
A4 short-edge	●	●	○	○
A4 long-edge	●	●	○	●
A5 long-edge 11" x 17"	○	○	●	●
B4, 8 1/2" x 14"	●	○	●	○
B5 long-edge, 8 1/2" x 11"	●	○	○	○
B5 short-edge, 11" x 8 1/2"	○	●	●	●
* (Asterisk)	○	●	○	●

○: ON (Pushed)
 ●: OFF (Not pushed)

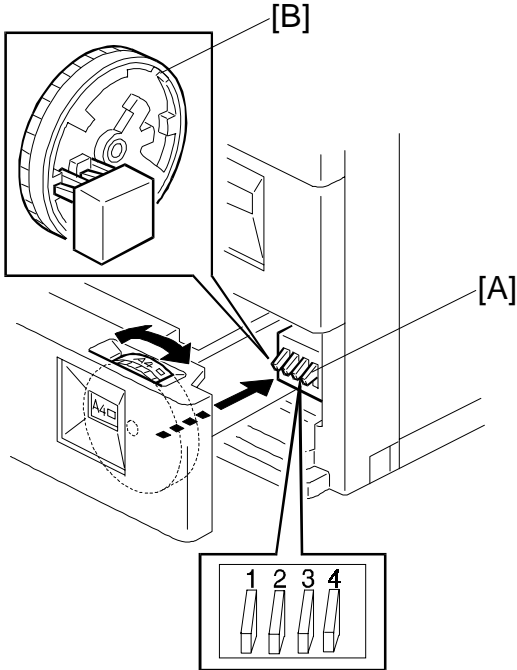

Paper Tray
 Unit
 B385

There are four paper size microswitches [A] on the front right plate of the paper tray unit. The switches are actuated by a paper size actuator [B] behind the paper size indicator plate, which is on the front right of the tray.

Each paper size has its own actuator, with a unique combination of notches. To determine which size tray has been installed, the CPU reads which microswitches the actuator has switched off.

The CPU disables paper feed from a tray if the paper size cannot be detected. If the paper size actuator is broken, or if there is no tray installed, the Add Paper indicator will light.

When the paper size actuator is at the "*" mark, the paper tray can be set up to accommodate one of a wider range of paper sizes by using user tools. If the paper size for this position is changed without changing the user tool setting, a paper jam will result.

2.6 SIDE AND END FENCES

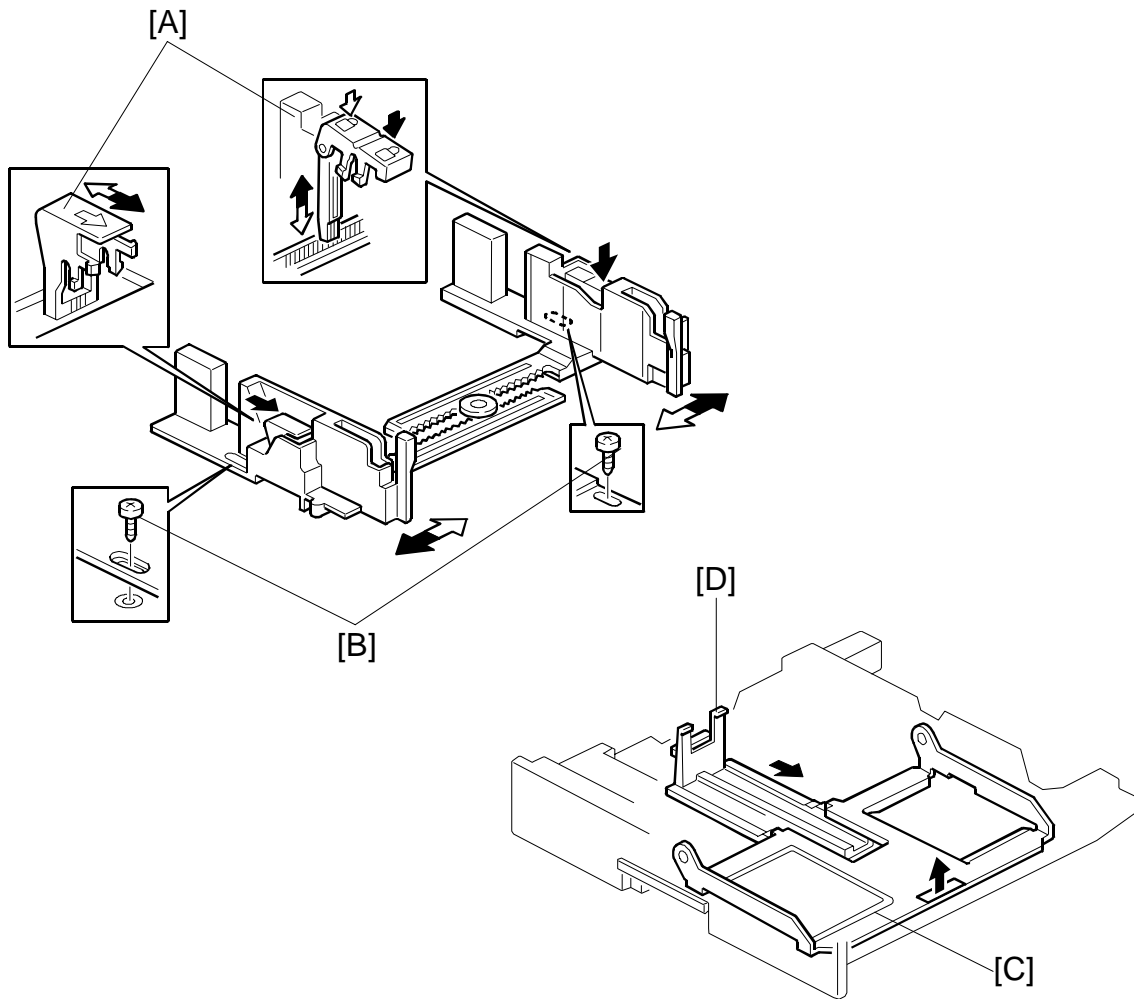

Side Fences

If the tray is full of paper and it is pushed in strongly, the fences may deform or bend. This may cause the paper to skew or the side-to-side registration to be incorrect. To correct this, each side fence has a stopper [A] attached to it. Each side fence can be secured with a screw [B], for customers who do not want to change the paper size.

End Fence

As the amount of paper in the tray decreases, the bottom plate [C] lifts up gradually. The end fence [D] is connected to the bottom plate. When the tray bottom plate rises, the end fence moves forward and pushes the back of the paper stack to keep it squared up.

3. REPLACEMENT AND ADJUSTMENT

3.1 FEED ROLLER REPLACEMENT

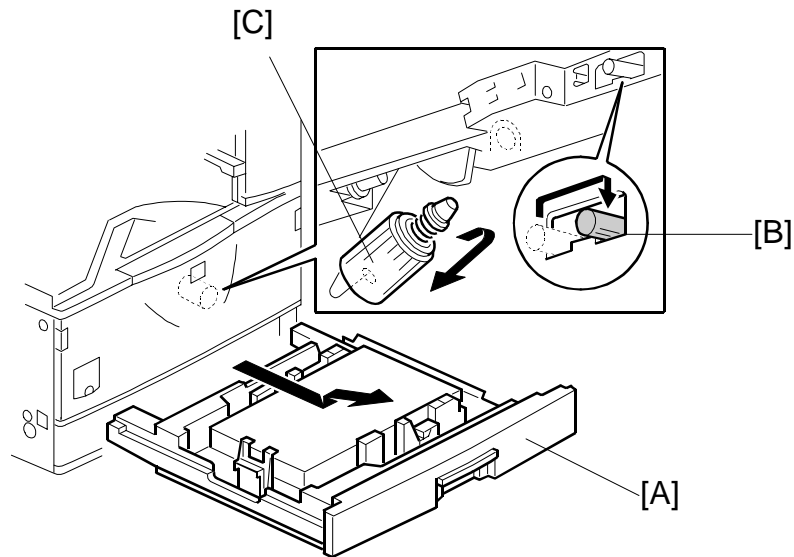

Paper Tray
Unit
B385

1. [A] Paper tray
2. Move the release lever [B] to the front.
3. Pull the feed roller [C] to the operation side and remove it.

3.2 TRAY MAIN BOARD REPLACEMENT

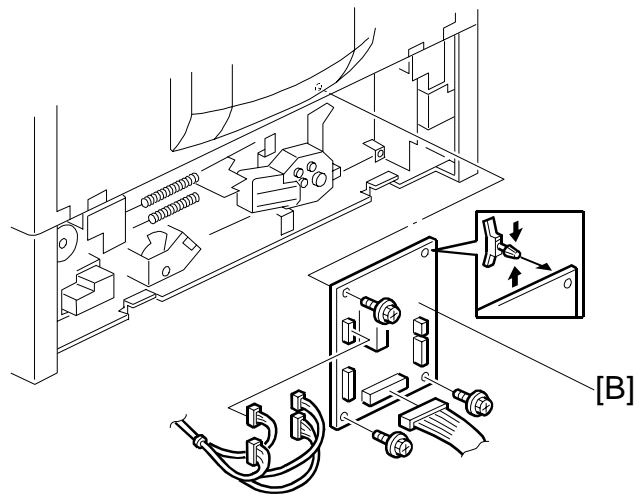
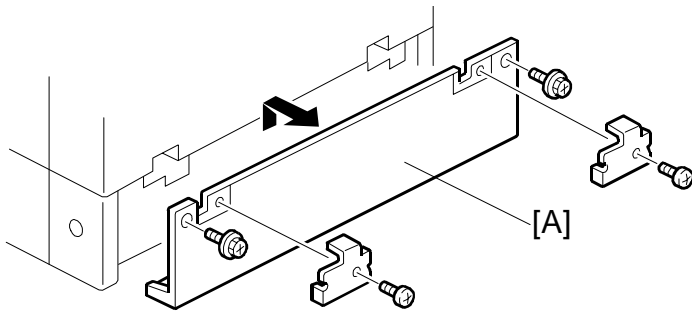

1. [A] Rear cover (🔩 x 4)
2. [B] Tray main board [B] (🔩 x 3, 📏 x 5)

3.3 TRAY MOTOR REPLACEMENT

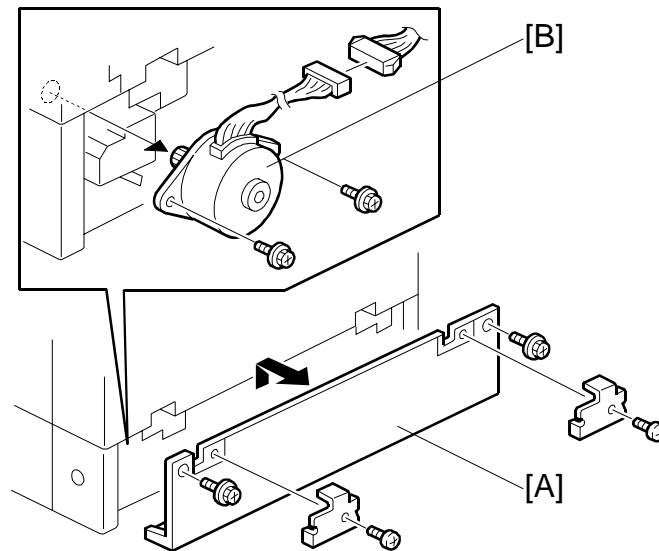

1. [A] Rear cover (🔩 x 4)
2. [B] Tray motor (🔩 x 2, 📡 x 1)

Paper Tray
Unit
B385

3.4 LIFT MOTOR REPLACEMENT

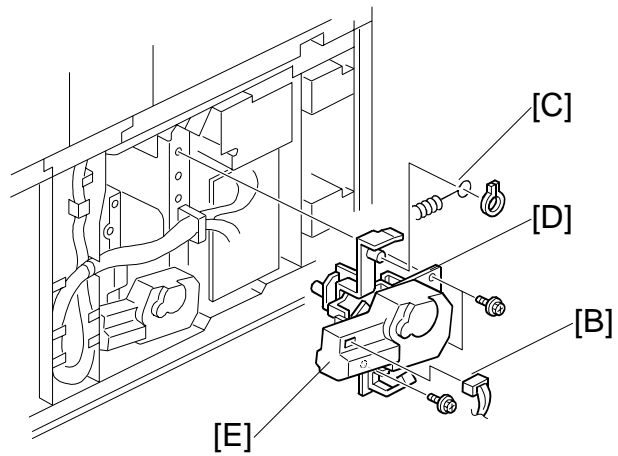
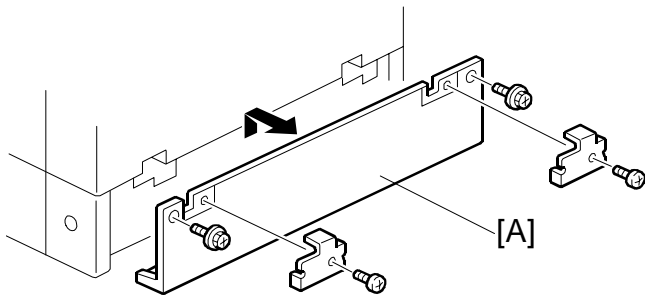

1. Pull out the paper tray.
2. [A] Rear cover (⚙️ x 4)
3. [B] 2P connector
4. [C] Spring
5. [D] Lift motor unit (⚙️ x 3)
6. [E] Lift motor (⚙️ x 3)

3.5 PAPER END SENSOR REPLACEMENT

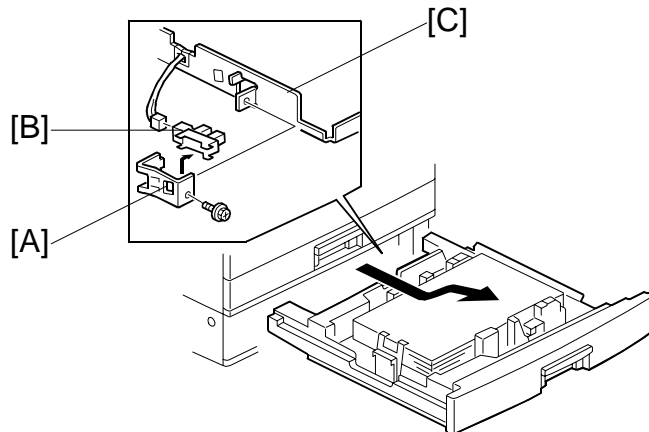

Paper Tray
Unit
B385

1. Paper tray
2. [A] Paper end sensor bracket (⚙ x 1, 📏 x 1)
3. [B] Paper end sensor

NOTE: After replacing the sensor, pull the sensor cable to the right side of the frame [C] so that the cable does not touch the paper in the tray.

3.6 PAPER SIZE SWITCH REPLACEMENT

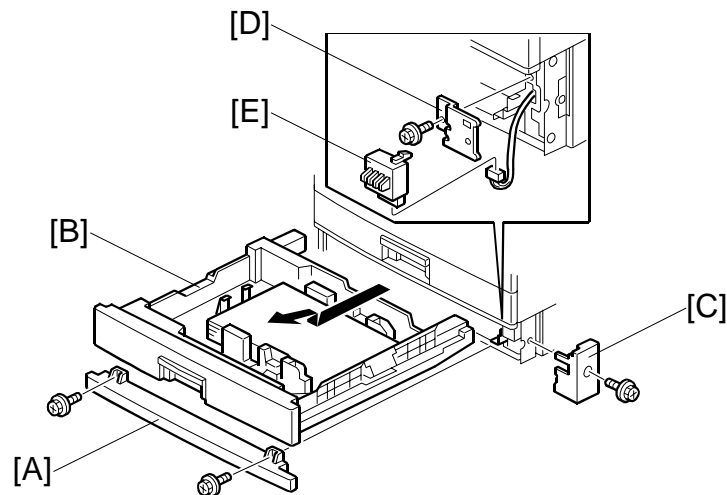

1. [A] Lower tray cover (⚙ x 2)
2. [B] Paper tray
3. [C] Right front cover (⚙ x 1)
4. [D] Paper size switch bracket (⚙ x 1)
5. [E] Paper size switch (📏 x 1)

SPECIFICATIONS

SPECIFICATIONS

1. GENERAL SPECIFICATIONS

Configuration:	Desktop
Copy Process:	Dry electrostatic transfer system
Originals:	Sheet/Book
Original Size:	Maximum A3/11" x 17"
Copy Paper Size:	Maximum A3/11" x 17" Minimum A5 LEF/8 1/2" x 5 1/2" (Paper tray) A6 SEF/5 1/2" x 8 1/2" (Bypass) Custom sizes in the bypass tray: Width: 90 – 305 mm (3.5" – 12.0") Length: 148 – 1,260 mm (5.8" – 49.6")
Copy Paper Weight:	Paper Tray: 60 – 90 g/m ² , 16 – 24 lb. Bypass: 52 – 162 g/m ² , 14 – 43 lb.
Reproduction Ratios:	3 enlargement and 4 reduction

	A4/A3 Version	LT/DLT Version
Enlargement	200%	155%
	141%	129%
	122%	121%
Full Size	100%	100%
Reduction	93%	93%
	82%	78%
	71%	65%
	50%	50%

Zoom:	50% to 200%, in 1% steps
Power Source:	Taiwan 110 V, 50/60 Hz 12 A America 120 V, 50/60 Hz 12 A Europe, Asia 220 – 240 V, 50/60 Hz 7 A

SPECIFICATIONS

Power Consumption:

	Mainframe Only		Full System	
	120 V	220 ~ 240 V	120 V	220 ~ 240 V
Maximum	Not above 1.1 kW	Not above 1.0 kW	Not above 1.2 kW	Not above 1.2 kW
Copying	Not above 480 W	Not above 480 W	Not above 480 W	Not above 480 W
Warm-up	Not above 880 W	Not above 780 W	Not above 890 W	Not above 790 W
Standby	Not above 125 W	Not above 125 W	Not above 125 W	Not above 125 W
Low Power Level 1	Not above 70 W	Not above 70 W	Not above 80 W	Not above 80 W
Low Power Level 2	Not above 40 W	Not above 40 W	Not above 50 W	Not above 50 W
Night/Off	Not above 1 W	Not above 1 W	N/A	N/A

NOTE: Full system - Maximum possible power consumption (any combination of mainframe and options), excluding optional heaters, key counter, fax unit, and printer controller.

Noise Emission

	Sound Power Level	Sound Pressure Level
Standby (Mainframe/Full system):	Not above 39.6 dB(A)	Not above 28.2 dB(A)
Operating (Mainframe only):	Not above 60.1 dB(A)	Not above 51.2 dB(A)
Operating (Full System):	Not above 62.9 dB(A)	Not above 53.6 dB(A)

NOTE: The above measurements were made in accordance with ISO 7779. Measurements were taken from the normal position of the operator.

Dimensions (W x D x H)

B039: 550 x 568 x 420 mm (21.7" x 22.4" x 16.5")

B040: 550 x 568 x 518 mm (21.7" x 22.4" x 20.4")

B043: 587 x 568 x 518 mm (23.1" x 22.4" x 20.4")

NOTE: Measurement Conditions

- 1) With bypass feed table closed
- 2) Without the A(R)DF

Weight

B039: 35 kg (77 lb.)

B040: 42 kg (92 lb.)

B043: 45 kg (99 lb.)

(Excluding A(R)DF, platen cover, toner, and developer)

Copying Speed in Multicopy Mode (copies/minute):

	A4 LEF/ 11" x 8 1/2"	B4 / 8 1/2" x 14"	A3 / 11" x 17"
Non-memory copy mode B039:	15	9	8
Memory copy mode B039*: B040/B043:	15 18	10 12	9 10
DF 1-to-1 B039*: B040/B043:	15 15	10 10	8 9
1-sided → 2-sided 2-sided → 2-sided B043:	15	6	4
DF 1-to-1 (1-sided to 2-sided) B043:	6	5	4
DF 1-to-1 (2-sided to 2-sided) B043:	6	4	4

*Requires 16MB base memory, which is optional on all B039 models outside North America, and standard on all other models.

NOTE: Measurement Conditions:

- 1) Figures are for one-sided original to one-sided copy only, except where noted otherwise
- 2) Not APS mode
- 3) 100% size

Warm-up Time: NA models: Less than 20 seconds (at 20°C [68°F])
Others: Less than 25 seconds (at 20°C [68°F])

First Copy Time: Not more than 6.9 seconds
NOTE: Measurement Conditions
1) From the ready state, with the polygonal mirror motor spinning.
2) A4/LT copying
3) Not APS mode
4) 100%size
5) Paper feed from the upper tray

Copy Number Input: Numeric keypad, 1 to 99 (increment, decrement)

Manual Image Density: 5 steps

Automatic Reset: Default is 60 seconds. Can be set from 10 to 999 seconds with user tools.

Automatic Shut-off: Default is 30 minutes. Can be set from 1 to 240 minutes with user tools.



SPECIFICATIONS

Copy Paper Capacity:	Paper Tray: 250 sheets (B039) 250 sheets x 2 (B040/B043) Optional Paper Tray Unit: 500 sheets x 1, or 500 sheets x 2 Bypass Tray: 100 sheets (sheets up to 432 mm [17"]) 10 sheets (sheets longer than 432 mm [17"]) 40 postcards 10 envelopes NOTE: Copy weight: 80 g/m ² (20 lb.)
Toner Replenishment:	Cartridge replacement (260 g/cartridge)
Optional Equipment:	<ul style="list-style-type: none">• Platen cover• Auto document feeder• Auto-reverse document feeder• Paper tray unit (1 tray)• Paper tray unit (2 trays)• Tray heater• Optics anti-condensation heater
Toner Yield:	9k copies (A4 LEF, 6% full black, 1 to 2 copying, normal text mode)
Copy-Tray Capacity	250 sheets
Memory Capacity	
• B039 (outside North America):	0 standard; 16MB (IMB) and 32MB DIMM as options (max. 48MB) [Since the DIMM installs onto the IMB, the DIMM option requires the presence of the IMB option.]
• B039 (North America), B040, B043	16MB IMB standard; 32MB DIMM as option (max. 48MB)

Duplex Unit (B043 only)

Copy Paper Size:	Maximum A3/11" x 17" Minimum A5/8 1/2" x 11"
Copy Paper Weight:	64 – 90 g/m ² (20 – 24 lb.)

2. MACHINE CONFIGURATION

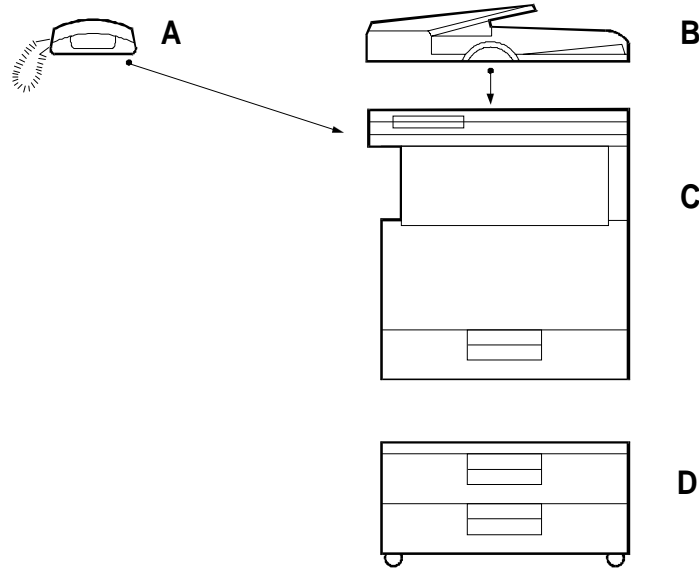

Spec.

Version	Item	Machine Code	Letter.
Copier	Copier (1-tray model)	B039	C
	Copier (2-tray non-duplex model)	B040	C
	Copier (2-tray with duplex)	B043	C
	Platen Cover (optional)	B406	
	ADF (optional)	B387	B
	ARDF (optional)	B379	B
	Paper Tray Unit – 1 tray (optional)	B385	D
	Paper Tray Unit – 2 trays (optional)	B384	D
	16MB IMB memory board (for B039 models outside North America only [all other models include this as standard])	B407	
	32MB Memory (optional)	G578	
	Tray Heater (optional)	—	
	Optics Anti-condensation Heater (optional)	—	
	Fax Unit	Fax Controller (optional)	B404
Handset (optional)		B433	A
Printer	Printer Controller (optional)	B405	
	NIB (optional)	B430	
	32MB Memory (optional)	G578	
	64MB Memory (optional)	G579	
	128MB Memory (optional)	G580	
	PS2 (optional)	B431	

SPECIFICATIONS

3. OPTIONAL EQUIPMENT

ARDF

Original Size:	Standard sizes Single-sided mode: A3 to A5, 11" x 17" to 5 1/2" x 8 1/2" Double-sided mode: A3 to A5, 11" x 17" to 5 1/2" x 8 1/2" Non-standard sizes (Single-sided mode only) Max. width 297 mm Min. width 105 mm Max. length 1260 mm Min. length 128 mm
Original Weight:	Single-sided mode: 40 – 28 g/m ² , 10 – 34 lb. Double-sided mode: 52 – 105 g/m ² , 14 – 28 lb.
Table Capacity:	50 sheets (80 g/m ² , 70 kg)
Original Standard Position:	Center
Separation:	FRR
Original Transport:	Roller transport
Original Feed Order:	From the top original
Reproduction Range:	50 to 200% (Sub scan direction only)
Power Source:	24 and 5 Vdc from the copier
Power Consumption:	50 W
Dimensions (W x D x H):	550 x 470 x 130 mm
Weight:	10 kg

ADF

Original Size:	Standard sizes (Single-sided mode only): A3 to A5, 11" x 17" to 5 1/2" x 8 1/2" Non-standard sizes (Single-sided mode only): Max. width 297 mm Min. width 105 mm Max. length 1,260 mm Min. length 128 mm
Original Weight:	52 – 105 g/m ² (14 – 28 lb.)
Table Capacity:	30 sheets (80 g/m ² , 22 lb.)
Original Standard Position:	Center
Separation:	FRR
Original Transport:	Roller transport
Original Feed Order:	From the top original
Reproduction Range:	50 – 200%
Power Source:	24 and 5 Vdc from the copier
Power Consumption:	25 W
Dimensions (W x D x H):	550 mm x 470 mm x 90 mm
Weight:	Not above 7 kg

SPECIFICATIONS

ONE-TRAY PAPER TRAY UNIT

Paper Size:	A5 to A3 5 1/2" x 8 1/2" SEF to 11" x 17"
Paper Weight:	60 – 105 g/m ² , 16 – 28 lb.
Tray Capacity:	500 sheets (80 g/m ² , 20 lb.) x 1 tray
Paper Feed System:	Feed roller and friction pad
Paper Height Detection:	4 steps (100%, 70%, 30%, Near end)
Power Source:	24 Vdc and 5Vdc (from the copier/printer): 120 Vac: 120 V version, from the copier/printer when the optional tray heater is installed 220 – 240 Vac: 230 V version, from the copier/printer when the optional tray heater is installed
Power Consumption:	Max: 20 W (Copying/printing) 23 W (Optional Tray Heater On) Average: 13 W (Copying/printing) 15 W (Optional Tray Heater On)
Weight:	12 kg (26.4 lb.)
Size (W x D x H):	550 mm x 520 mm x 134 mm

TWO-TRAY PAPER TRAY UNIT

Paper Size:	A5 to A3 5 1/2" x 8 1/2" SEF to 11" x 17"
Paper Weight:	60 – 105 g/m ² , 16 – 28 lb.
Tray Capacity:	500 sheets (80 g/m ² , 20 lb.) x 2 trays
Paper Feed System:	Feed roller and friction pad
Paper Height Detection:	4 steps (100%, 70%, 30%, Near end)
Power Source:	24 Vdc, 5 Vdc (from the copier/printer) 120 Vac: 120 V version, from the copier/printer when the optional tray heater is installed 220 – 240 Vac: 230 V version, from the copier/printer when the optional tray heater is installed
Power Consumption:	Max: 30 W (Copying/printing) 23 W (Optional Tray Heater On) Average: 17 W (Copying/printing) 15 W (Optional Tray Heater On)
Weight:	25 kg (55 lb.)
Size (W x D x H):	550 mm x 520 mm x 271 mm

16MB IMB (Copier Memory Unit)*

Memory: 16MB (with slot for 32MB expansion DIMM)

*This component is included as standard on all models other than B039 machines sold outside of North America.

B120 (RLA only)

12. B120 (RLA ONLY)

12.1 INSTALLATION

Same as the B039, except that the B120 does not have an ARDF, Paper Tray Unit, Fax or Printer option.

12.2 PREVENTIVE MAINTENANCE SCHEDULES

There is no APS sensor.
There is no ARDF or Paper Tray Unit.

12.3 REPLACEMENT AND ADJUSTMENT

There is no APS sensor.

12.4 TROUBLESHOOTING

Same as B039.

12.5 SERVICE TABLES

12.5.1 SP MODE TABLES

SP4-301: APS Data Display

Only the platen cover status is operating (1st digit). All other digits show a value of 0.

SP4-303: APS Small Size Original

Only a value of 0 is possible (not detected), since there is no APS sensor.

SP5-907: Plug & Play Setting

The production names have been changed.

SP5-911: APS A4/LT Priority

Changing the setting has no effect.

SP5-914: Printer Counter Display

Only a value of 0 is possible (No).

SP5-944: APS Mode Setting

Only a value of 0 is possible (No).

SP7-211: Display - APS Working Time

SP display is incorrect (but irrelevant since there is no APS sensor).

SERVICE TABLES

12.5.2 COPY FEATURES TABLE (USER TOOLS)

System Setting Table

2. System Settings	1. Copy Count Display	
	2. Energy Saver Timer	
	3. Energy Saver Level	
	4. Auto Off Timer	
	5. AOF (Keep It On.)	
	6. Special Paper Size	
	7. Paper Tray Priority	
	8. Auto Tray Switch	
	9. Display Contrast	
	10. Key Operators Tools	
	2. Print Counter List	
	3. Key Operator Access	
	4. Program Key Operator Code	
	5. Restricted Access	

Copy Features Table

3. Copier Features	1. Max. Copy Q'ty		
	2. Adjust Original Mode		
	3. Set Ratio		1. Text
			2. Photo
	4. Copy Reset Timer		
	5. SADF Auto Reset		
	6. Key Operator Tools		1. User Code Access
			2. Check Copy Counter
			3. Print Counter List
			4. Reset Counter
	5. Clear all User Codes		
	6. Reset All Counters		
	7. Program User Code		
	8. Change User Code		
	9. Delete User Code		

12.6 DETAILED SECTION DESCRIPTIONS

- There is no APS sensor.
- There is no ARDF or Paper Tray Unit.
- There is no FAX or Printer option.

12.7 SPECIFICATIONS (DIFFERENCES ARE HIGHLIGHTED IN *ITALICS*)

		B120	B040 Series
Copy speed		<i>13cpm</i>	15cpm
Memory capacity	std	<i>0MB</i>	NA: 16MB EU: 0MB
	option	<i>16MB, 32MB</i>	16MB, 32MB
Paper Capacity	std	<i>250 sheet x 1 + 100 sheet bypass</i>	250 sheet x 1 + 100 sheet bypass
	max	<i>350 sheets</i>	1350 sheets
Max CV		<i>10K outputs/month</i>	10K outputs/month
Duty		<i>30K outputs/month</i>	30K outputs/month
APS/AMS		<i>No</i>	Yes
Scan once copy many		<i>Yes with 16MB memory</i>	Yes with 16MB memory
Electronic sort		<i>Yes with 16MB memory</i>	Yes with 16MB memory
Image Rotation		<i>No</i>	Yes with 16MB memory
Series Copy		<i>No</i>	Yes with 16MB memory
Combine Copy		<i>No</i>	Yes with 16MB memory
Option	Platen Cover	<i>Yes</i>	Yes
	ADF	<i>Yes</i>	Yes
	Paper Bank	<i>No</i>	Yes
	Copier memory	<i>Yes</i>	Yes
	Fax option	<i>No</i>	Yes
	Printer option	<i>No</i>	Yes

B120
(RLA only)

FAX UNIT B404

Lithium Batteries

 **CAUTION**

The danger of explosion exists if battery on the FCU is incorrectly replaced. Replace only with the same or an equivalent type recommended by the manufacturer. Discard used batteries in accordance with the manufacturer's instructions.

INSTALLATION

1. INSTALLATION

- NOTE:**
- 1) Never install telephone wiring during a lightning storm.
 - 2) Never install telephone jacks in wet locations unless the jack is specifically designed for wet locations.
 - 3) Never touch uninsulated telephone wires or terminals unless the telephone line has been disconnected at the network interface.
 - 4) Use caution when installing or modifying telephone lines.
 - 5) Avoid using a telephone (other than a cordless type) during an electrical storm. There may be a remote risk of electric shock from lightning.
 - 6) If there is a gas leak, do not use the telephone in the vicinity of the leak to report it.

CAUTION

1. Before installing the fax unit, switch off the main power and operation switches, and disconnect the power cord.
2. The fax unit contains a lithium battery. The danger of explosion exists if a battery of this type is incorrectly replaced. Replace only with the same or an equivalent type recommended by the manufacturer. Discard used batteries in accordance with the manufacturer's instructions.

Fax Unit B404

1.1 INSTALLATION REQUIREMENTS

1.1.1 ENVIRONMENT

Refer to the base copier's service manual.

1.1.2 MACHINE LEVEL

Refer to the base copier's service manual.

1.1.3 MINIMUM SPACE REQUIREMENTS

Refer to the base copier's service manual.

1.1.4 POWER REQUIREMENTS

Refer to the base copier's service manual.

FAX UNIT

1.2 FAX UNIT

1.2.1 ACCESSORY CHECK

No.	Description	Q'ty
1	Fax unit	1
2	Stamp cartridge	1
3	Main switch cover	1
4	SG3 decal	1
5	Mylars	2
6	Operation manual – Basic	1
7	Operation manual – Advanced	1
8	Operation panel	1
9	Function key	1
10	Copy key	1
11	FCU-PSU relay cable	1
12	Telephone cable (only for N. America)	1
13	Handset bracket (only for N. America)	1
14	Screw	5

1.2.2 INSTALLATION PROCEDURE

⚠ CAUTION

1. If there is a printer option in the machine, print out all data in the printer buffer.
2. If a printer option is already installed, remove it first, then install the fax option. After that, re-install the printer option in the machine.
3. Turn off the main switch and disconnect the power cord and the printer network cable.

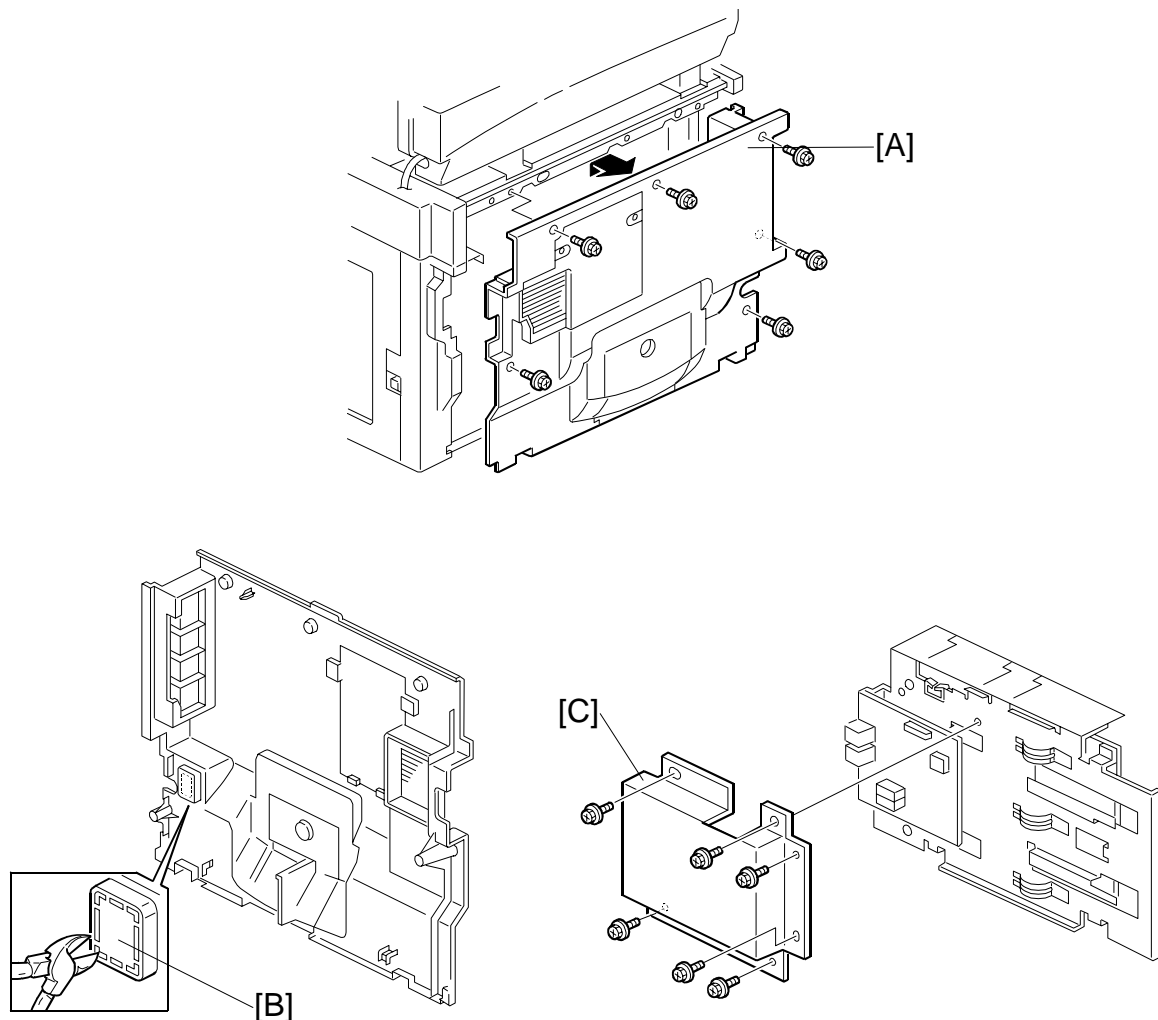

1. Remove the rear cover [A] (6 screws).
2. Cut away the small window [B] on the rear cover as shown.
3. Remove the NCU cover [C] from the fax unit.

NOTE: European and Asian models only

FAX UNIT

- Connect the following pins on switch TB1 on the FCU and TB1 – TB3 on the NCU. After that, replace the NCU cover.

NOTE: European and Asian models only

Individual Switch Settings:

Country	FCU		NCU	
	TB1	TB1	TB2	TB3
CTR21, Israel	2-5	2-3	OFF	ON
Poland	2-5	2-3	ON	OFF
Australia	2-5	1-2	OFF	ON
New Zealand	2-5	1-2	ON	OFF
Malaysia, South Africa	3-4	1-2	OFF	ON
Asia and others	3-4	1-2	ON	OFF

NOTE: It is necessary to change the country code in both system switch 0F and NCU function 08-0.

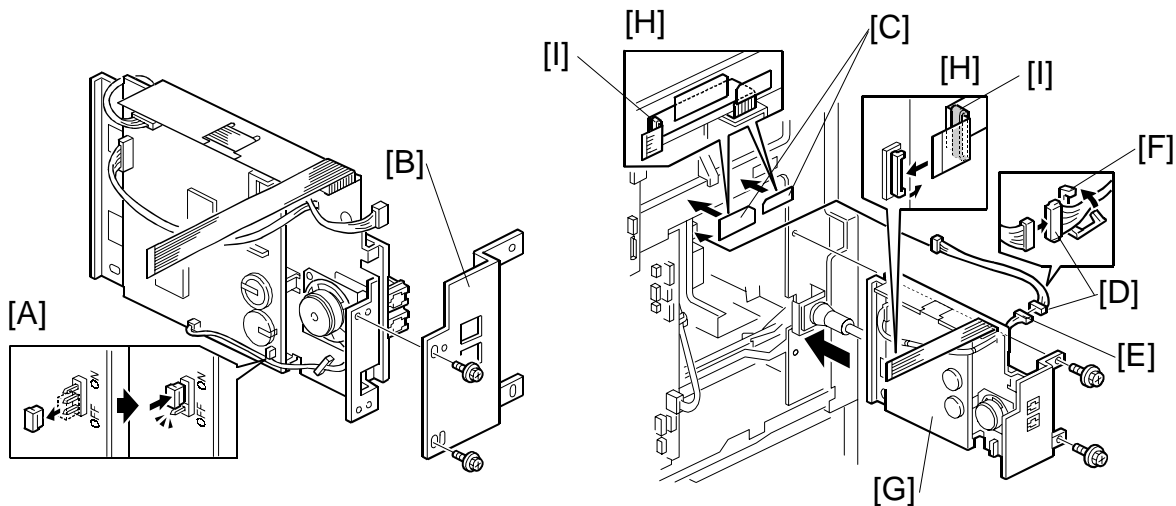

- Change the battery switch [A] on the FCU to ON as shown.
- Attach the bracket [B] (2 screws) as shown.
- Attach the two mylars [C] to the rear bracket of the mainframe as shown.
- Connect the relay cable [D] to the PSU first, then connect it to the FCU-PSU cable [E], then secure cable [D] with clamp [F], then install the fax unit [G] (2 screws).
- Run the flat cable [H] through between the mylars and the rear bracket of the mainframe, then connect the flat cable [H] to the BiCU.
NOTE: If the printer option will be installed at the same time, run the flat cable [H] through the core [I] (contained in the printer option) as shown.
- Replace the rear cover.

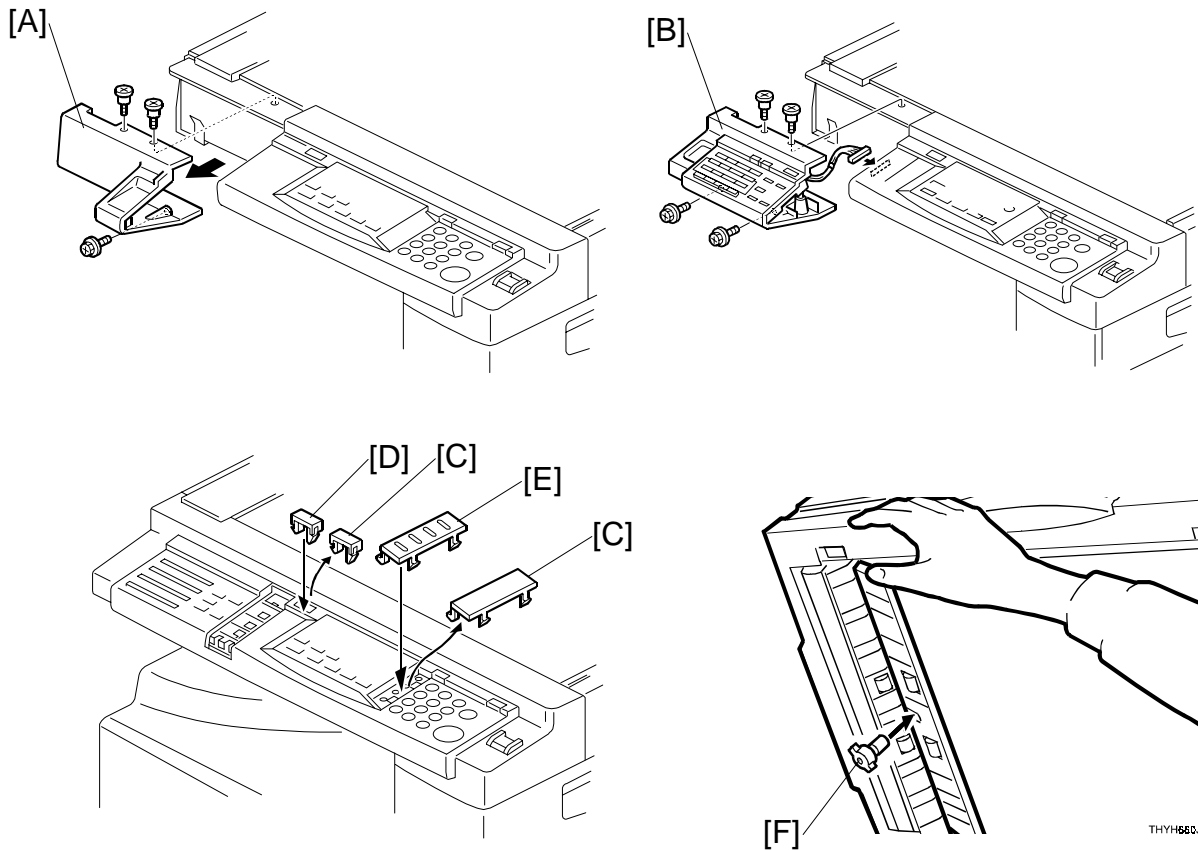

11. Remove the operation panel cover [A] (3 screws).
12. Install the fax operation panel [B] (4 screws).
13. Remove the small covers [C], then attach the copy key [D] and function keys [E] as shown.
14. If the ADF/ARDF has been installed, install the stamp cartridge [F] as shown.
15. Attach the super G3 decal [G] and cover [H] to the front cover as shown.
16. Connect the telephone line to the "LINE" jack at the rear of the machine.

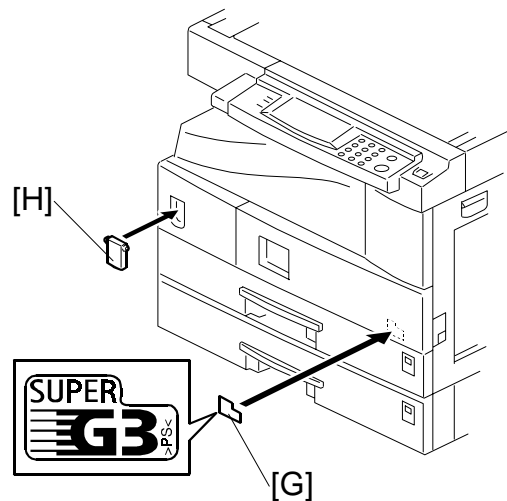

FAX UNIT

17. Plug in the machine and turn on the main power switch.

NOTE: The copier must be connected to a properly-grounded socket outlet.

18. Press the “Facsimile” key. At this time, the display shows: Call Service FAX SC1201 Data should be initialized.

NOTE: This is not a functional problem. The machine shows this message only when the fax unit is first installed. If the same message appears at the next power on, check whether the battery switch on the FCU has been turned on.

19. Press “OK” to initialize the fax unit.

11. Be sure to set the clock. (Date and time ➤ Operation Manual Advanced Features / 5. Facsimile User Tools)

21. Program items required for fax communication.

1.3 HANDSET

1.3.1 ACCESSORY CHECK

No.	Description	Q'ty
1	Handset	1
2	Screw M3x12	2
3	Screw M3x8	2
4	Handset manual	1

1.1.2 INSTALLATION PROCEDURE

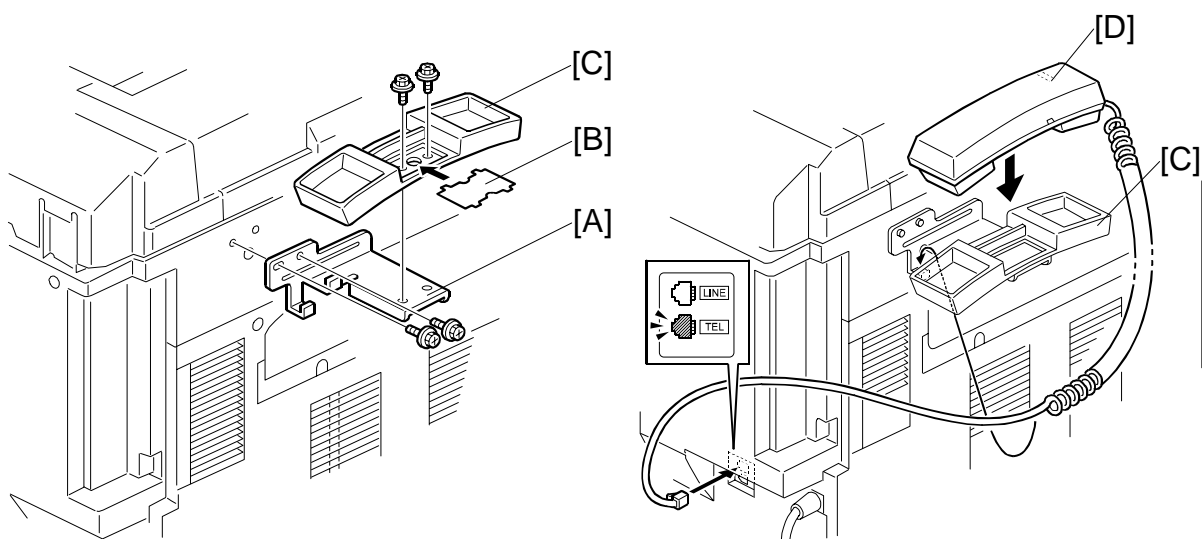

Fax Unit B404

1. Attach the bracket [A] enclosed with the fax unit (2 screws) as shown.
2. Remove the label [B] from the handset cradle [C]. Attach the cradle [B] to the bracket [A] (2 screws), then replace the label [B].
3. Install the handset [D] on the cradle [C], then connect the cable to the "TEL" jack at the rear of the machine.

PREVENTIVE MAINTENANCE

2. PREVENTIVE MAINTENANCE

2.1 SPECIAL TOOLS AND LUBRICANTS

- Flash Memory Card – 4MB (P/N: A2309352)
- Card Case (P/N: A2309351)

2.2 PM TABLE

No PM necessary for the fax option.

REMOVAL AND REPLACEMENT

3. REMOVAL AND REPLACEMENT

3.1 PRECAUTION

CAUTION

Before starting disassembly, be sure to print all message files in the SAF memory. Then, turn off the main power switch and disconnect the power cord and telephone cable for safety.

Lithium Battery

The danger of explosion exists if a battery of this type is incorrectly replaced. Replace only with the same or an equivalent type recommended by the manufacturer. Discard used batteries in accordance with the manufacturer's instructions.

3.2 FCU

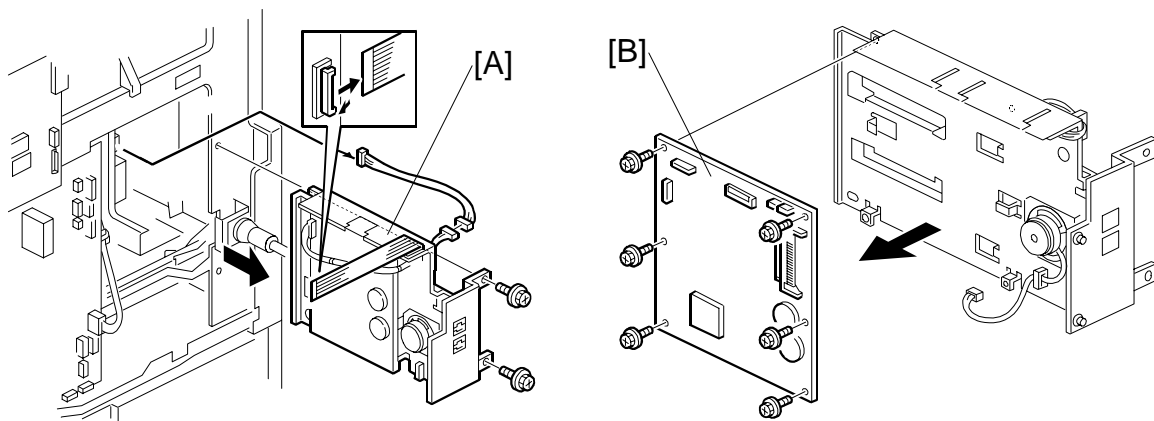

[A]: Fax unit (🔧 2, 📁 2)

[B]: FCU (🔧 6, 📁 2)

3.3 NCU

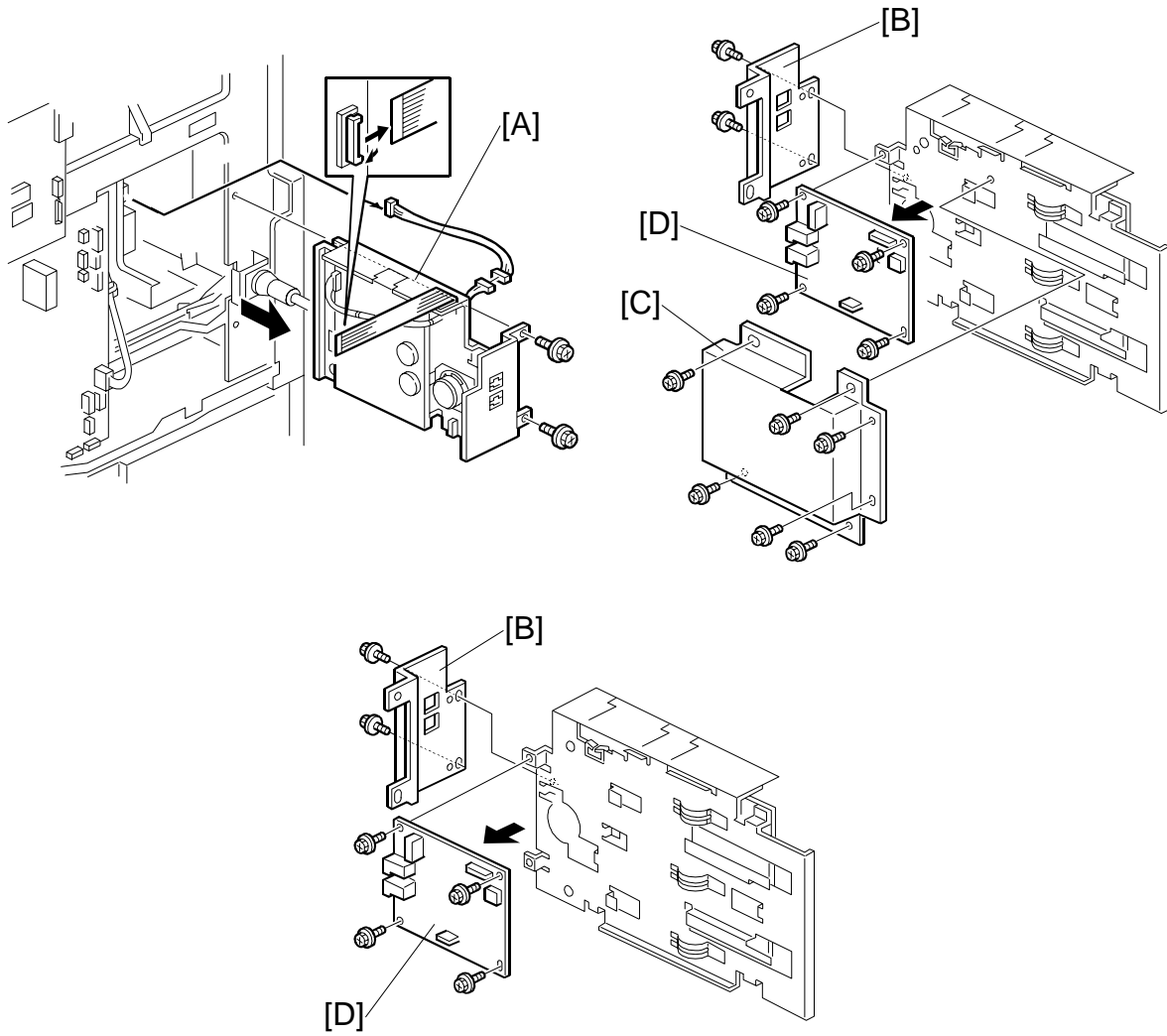

[A]: Fax unit (🔩 2, 📎 2)

[B]: Bracket (🔩 2)

[C]: NCU cover (🔩 6) (European and Asian models only)

[D]: NCU (🔩 4, 📎 1)

3.4 SPEAKER

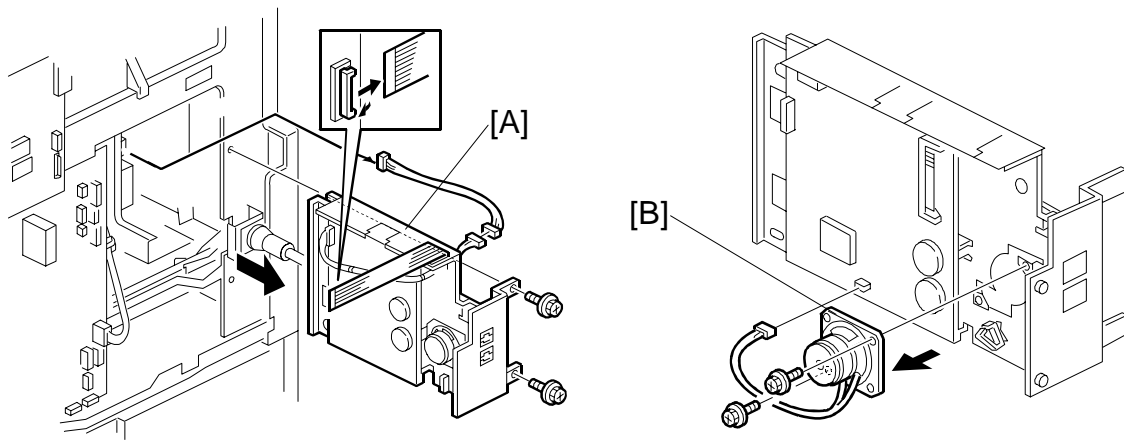

[A]: Fax unit (🔧 2, 📏 2)

[B]: Speaker (🔧 2, 📏 1)

TROUBLESHOOTING

4. TROUBLESHOOTING

4.1 ERROR CODES

If an error code occurs, retry the communication. If the same problem occurs, try to fix the problem as suggested below. Note that some error codes appear only in the error code display and on the service report.

Code	Meaning	Suggested Cause/Action
0-00	DIS/NSF not detected within 40 s of Start being pressed	<ul style="list-style-type: none"> • Check the line connection. • Check the NCU - FCU connectors. • The machine at the other end may be incompatible. • Replace the NCU or FCU. • Check for DIS/NSF with an oscilloscope. • If the rx signal is weak, there may be a bad line.
0-01	DCN received unexpectedly	<ul style="list-style-type: none"> • The other party is out of paper or has a jammed printer. • The other party pressed Stop during communication.
0-03	Incompatible modem at the other end	<ul style="list-style-type: none"> • The other terminal is incompatible.
0-04	CFR or FTT not received after modem training	<ul style="list-style-type: none"> • Check the line connection. • Check the NCU - FCU connectors. • Try changing the tx level and/or cable equalizer settings. • Replace the FCU or NCU. • The other terminal may be faulty; try sending to another machine. • If the rx signal is weak or defective, there may be a bad line. <p>Cross reference</p> <ul style="list-style-type: none"> • Tx level - NCU Parameter 01 (PSTN) • Cable equalizer - G3 Switch 07 (PSTN) • Dedicated Tx parameters
0-05	Unsuccessful after modem training at 2400 bps	<ul style="list-style-type: none"> • Check the line connection. • Check the NCU - FCU connectors. • Try adjusting the tx level and/or cable equalizer. • Replace the FCU or NCU. • Check for line problems. <p>Cross reference</p> <ul style="list-style-type: none"> • See error code 0-04.

ERROR CODES

Code	Meaning	Suggested Cause/Action
0-06	The other terminal did not reply to DCS	<ul style="list-style-type: none"> • Check the line connection. • Check the FCU - NCU connectors. • Try adjusting the tx level and/or cable equalizer settings. • Replace the NCU or FCU. • The other end may be defective or incompatible; try sending to another machine. • Check for line problems. <p>Cross reference</p> <ul style="list-style-type: none"> • See error code 0-04.
0-07	No post-message response from the other end after a page was sent	<ul style="list-style-type: none"> • Check the line connection. • Check the FCU - NCU connectors. • Replace the NCU or FCU. • The other end may have jammed or run out of paper. • The other end user may have disconnected the call. • Check for a bad line. • The other end may be defective; try sending to another machine.
0-08	The other end sent RTN or PIN after receiving a page, because there were too many errors	<ul style="list-style-type: none"> • Check the line connection. • Check the FCU - NCU connectors. • Replace the NCU or FCU. • The other end may have jammed, or run out of paper or memory space. • Try adjusting the tx level and/or cable equalizer settings. • The other end may have a defective modem/NCU/FCU; try sending to another machine. • Check for line problems and noise. <p>Cross reference</p> <ul style="list-style-type: none"> • Tx level - NCU Parameter 01 (PSTN) • Cable equalizer - G3 Switch 07 (PSTN) • Dedicated Tx parameters
0-14	Non-standard post message response code received	<ul style="list-style-type: none"> • Check the FCU - NCU connectors. • Incompatible or defective remote terminal; try sending to another machine. • Noisy line: resend. • Try adjusting the tx level and/or cable equalizer settings. • Replace the NCU or FCU. <p>Cross reference</p> <ul style="list-style-type: none"> • See error code 0-08.

Code	Meaning	Suggested Cause/Action
0-15	The other terminal is not capable of specific functions.	The other terminal is not capable of accepting the following functions, or the other terminal's memory is full. <ul style="list-style-type: none"> • Confidential rx • Transfer function • SEP/SUB/PWD/SID
0-16	CFR or FTT not detected after modem training in confidential or transfer mode	<ul style="list-style-type: none"> • Check the line connection. • Check the FCU - NCU connectors. • Replace the NCU or FCU. • Try adjusting the tx level and/or cable equalizer settings. • The other end may have disconnected, or it may be defective; try calling another machine. • If the rx signal level is too low, there may be a line problem. <p>Cross reference</p> <ul style="list-style-type: none"> • See error code 0-08.
0-17	Communication was interrupted by pressing the Stop key.	If the Stop key was not pressed and this error keeps occurring, replace the operation panel.
0-20	Facsimile data not received within 6 s of retraining	<ul style="list-style-type: none"> • Check the line connection. • Check the FCU - NCU connectors. • Replace the NCU or FCU. • Check for line problems. • Try calling another fax machine. • Try adjusting the reconstruction time for the first line and/or rx cable equalizer setting. <p>Cross reference</p> <ul style="list-style-type: none"> • Reconstruction time - G3 Switch 0A, bit 6 • Rx cable equalizer - G3 Switch 07 (PSTN)
0-21	EOL signal (end-of-line) from the other end not received within 5 s of the previous EOL signal	<ul style="list-style-type: none"> • Check the connections between the FCU, NCU, & line. • Check for line noise or other line problems. • Replace the NCU or FCU. • The remote machine may be defective or may have disconnected. <p>Cross reference</p> <ul style="list-style-type: none"> • Maximum interval between EOLs and between ECM frames - G3 Bit Switch 0A, bit 4

fax Unit b404

ERROR CODES

Code	Meaning	Suggested Cause/Action
0-22	The signal from the other end was interrupted for more than the acceptable modem carrier drop time (default: 200 ms)	<ul style="list-style-type: none"> • Check the line connection. • Check the FCU - NCU connectors. • Replace the NCU or FCU. • Defective remote terminal. • Check for line noise or other line problems. • Try adjusting the acceptable modem carrier drop time. <p>Cross reference</p> <ul style="list-style-type: none"> • Acceptable modem carrier drop time - G3 Switch 0A, bits 0 and 1
0-23	Too many errors during reception	<ul style="list-style-type: none"> • Check the line connection. • Check the FCU - NCU connectors. • Replace the NCU or FCU. • Defective remote terminal. • Check for line noise or other line problems. • Try asking the other end to adjust their tx level. • Try adjusting the rx cable equalizer setting and/or rx error criteria. <p>Cross reference</p> <ul style="list-style-type: none"> • Rx cable equalizer - G3 Switch 07 (PSTN) • Rx error criteria - Communication Switch 02, bits 0 and 1
0-30	The other terminal did not reply to NSS(A) in AI short protocol mode	<ul style="list-style-type: none"> • Check the line connection. • Check the FCU - NCU connectors. • Try adjusting the tx level and/or cable equalizer settings. • The other terminal may not be compatible. <p>Cross reference</p> <ul style="list-style-type: none"> • Dedicated tx parameters
0-32	The other terminal sent a DCS, which contained functions that the receiving machine cannot handle.	<ul style="list-style-type: none"> • Check the protocol dump list. • Ask the other party to contact the manufacturer.
0-52	Polarity changed during communication	<ul style="list-style-type: none"> • Check the line connection. • Retry communication.
0-70	The communication mode specified in CM/JM was not available (V.8 calling and called terminal)	<ul style="list-style-type: none"> • The other terminal did not have a compatible communication mode (e.g., the other terminal was a V.34 data modem and not a fax modem.) • A polling tx file was not ready at the other terminal when polling rx was initiated from the calling terminal.
0-74	The calling terminal fell back to T.30 mode, because it could not detect ANSam after sending CI.	<ul style="list-style-type: none"> • The calling terminal could not detect ANSam due to noise, etc. • ANSam was too short to detect. • Check the line connection and condition. • Try making a call to another V.8/V.34 fax.

Code	Meaning	Suggested Cause/Action
0-75	The called terminal fell back to T.30 mode, because it could not detect a CM in response to ANSam (ANSam timeout).	<ul style="list-style-type: none"> The terminal could not detect ANSam. Check the line connection and condition. Try receiving a call from another V.8/V.34 fax.
0-76	The calling terminal fell back to T.30 mode, because it could not detect a JM in response to a CM (CM timeout).	<ul style="list-style-type: none"> The called terminal could not detect a CM due to noise, etc. Check the line connection and condition. Try making a call to another V.8/V.34 fax.
0-77	The called terminal fell back to T.30 mode, because it could not detect a CJ in response to JM (JM timeout).	<ul style="list-style-type: none"> The calling terminal could not detect a JM due to noise, etc. A network that has narrow bandwidth cannot pass JM to the other end. Check the line connection and condition. Try receiving a call from another V.8/V.34 fax.
0-79	The called terminal detected CI while waiting for a V.21 signal.	Check for line noise or other line problems. If this error occurs, the called terminal falls back to T.30 mode.
0-80	The line was disconnected due to a timeout in V.34 phase 2 – line probing.	<ul style="list-style-type: none"> The guard timer expired while starting these phases. Serious noise, narrow bandwidth, or low signal level can cause these errors. <p>If these errors happen at the transmitting terminal:</p> <ul style="list-style-type: none"> Try making a call at a later time. Try using V.17 or a slower modem using dedicated tx parameters. Try increasing the tx level. <p>If these errors happen at the receiving terminal:</p> <ul style="list-style-type: none"> Try adjusting the tx cable equalizer setting. Try adjusting the rx cable equalizer setting. Try increasing the tx level. Try using V.17 or a slower modem if the same error is frequent when receiving from multiple senders.
0-81	The line was disconnected due to a timeout in V.34 phase 3 – equalizer training.	
0-82	The line was disconnected due to a timeout in the V.34 phase 4 – control channel start-up.	
0-83	The line was disconnected due to a timeout in the V.34 control channel restart sequence.	
0-84	The line was disconnected due to abnormal signaling in V.34 phase 4 – control channel start-up.	
0-85	The line was disconnected due to abnormal signaling in V.34 control channel restart.	<ul style="list-style-type: none"> The signal did not stop within 10 s. Turn off the machine, then turn it back on. If the same error is frequent, replace the FCU.
0-86	The line was disconnected because the other terminal requested a data rate using MPh that was not available in the currently selected symbol rate.	<ul style="list-style-type: none"> The other terminal was incompatible. Ask the other party to contact the manufacturer.

ERROR CODES

Code	Meaning	Suggested Cause/Action
0-87	The control channel started after an unsuccessful primary channel.	<ul style="list-style-type: none"> The receiving terminal restarted the control channel because data reception in the primary channel was not successful. This does not result in an error communication.
0-88	The line was disconnected because PPR was transmitted/received 9 (default) times within the same ECM frame.	<ul style="list-style-type: none"> Try using a lower data rate at the start. Try adjusting the cable equalizer setting.
2-10	The modem cannot enter tx mode	<ul style="list-style-type: none"> Replace the FCU.
2-11	Only one V.21 connection flag was received	<ul style="list-style-type: none"> Replace the FCU.
2-12	Modem clock irregularity	<ul style="list-style-type: none"> Replace the FCU.
2-13	Modem initialization error	<ul style="list-style-type: none"> Turn off the machine, then turn it back on. Update the modem ROM. Replace the FCU.
2-20	Abnormal coding/decoding (cpu not ready)	<ul style="list-style-type: none"> Replace the FCU.
2-50	The machine resets itself for a fatal FCU system error	<ul style="list-style-type: none"> If this is frequent, update the ROM, or replace the FCU.
2-51	The machine resets itself because of a fatal communication error	<ul style="list-style-type: none"> If this is frequent, update the ROM, or replace the FCU.
3-30	Mismatched specifications (rx capability)	<ul style="list-style-type: none"> Check the receive capabilities requested from the other terminal.
4-01	Line current was cut	<ul style="list-style-type: none"> Check the line connector. Check the connection between FCU and NCU. Check for line problems. Replace the FCU or the NCU.
4-10	Communication failed because of an ID Code mismatch (Closed Network) or Tel. No./CSI mismatch (Protection against Wrong Connections)	<ul style="list-style-type: none"> Get the ID Codes the same and/or the CSIs programmed correctly, then resend. The machine at the other end may be defective.
5-00	Data construction not possible	<ul style="list-style-type: none"> Replace the FCU.
5-01	Data reconstruction not possible	
5-10	DCR timer expired	
5-20	Storage impossible because of a lack of memory	<ul style="list-style-type: none"> Temporary memory shortage. Test the SAF memory. Replace the FCU board
5-21	Memory overflow	

Code	Meaning	Suggested Cause/Action
5-22	Mode table overflow after the second page of a scanned document	<ul style="list-style-type: none"> • Wait for the messages which are currently in the memory to be sent or delete some files from memory.
5-23	Print data error when printing a substitute rx or confidential rx message	<ul style="list-style-type: none"> • Test the SAF memory. • Ask the other end to resend the message. • Replace the FCU board.
5-24	Memory overflow after the second page of a scanned document	<ul style="list-style-type: none"> • Try using a lower resolution setting. • Wait for the messages which are currently in the memory to be sent or delete some files from memory.
5-25	SAF file access error	<ul style="list-style-type: none"> • Replace the FCU board.
6-00	G3 ECM - T1 time out during reception of facsimile data	<ul style="list-style-type: none"> • Try adjusting the rx cable equalizer. • Replace the FCU or NCU.
6-01	G3 ECM - no V.21 signal was received	
6-02	G3 ECM - EOR was received	
6-04	G3 ECM - RTC not detected	<ul style="list-style-type: none"> • Check the line connection. • Check connections from the NCU to the FCU. • Check for a bad line or defective remote terminal. • Replace the FCU or NCU.
6-05	G3 ECM - facsimile data frame not received within 18 s of CFR, but there was no line fail	<ul style="list-style-type: none"> • Check the line connection. • Check connections from the NCU to the FCU. • Check for a bad line or defective remote terminal. • Replace the FCU or NCU. • Try adjusting the rx cable equalizer <p>Cross reference</p> <ul style="list-style-type: none"> • Rx cable equalizer - G3 Switch 07 (PSTN)
6-06	G3 ECM - coding/decoding error	<ul style="list-style-type: none"> • Defective FCU. • The other terminal may be defective.
6-08	G3 ECM - PIP/PIN received in reply to PPS.NULL	<ul style="list-style-type: none"> • The other end pressed Stop during communication. • The other terminal may be defective.
6-09	G3 ECM - ERR received	<ul style="list-style-type: none"> • Check for a noisy line. • Adjust the tx levels of the communicating machines. • See code 6-05.
6-10	G3 ECM - error frames still received at the other end after all communication attempts at 2400 bps	<ul style="list-style-type: none"> • Check for line noise. • Adjust the tx level (use NCU parameter 01 or the dedicated tx parameter for that address). • Check the line connection. • Defective remote terminal.

fax Unit b404

ERROR CODES

Code	Meaning	Suggested Cause/Action
6-21	V.21 flag detected during high speed modem communication	<ul style="list-style-type: none"> • The other terminal may be defective or incompatible.
6-22	The machine resets the sequence because of an abnormal handshake in the V.34 control channel	<ul style="list-style-type: none"> • Check for line noise. • If the same error occurs frequently, replace the FCU. • Defective remote terminal.
6-99	V.21 signal not stopped within 6 s	<ul style="list-style-type: none"> • Replace the FCU.
9-61	Memory overflow occurs during reception	Check the SAF.
22-00	Original length exceeded the maximum scan length	<ul style="list-style-type: none"> • Divide the original into a few pages. • Check the resolution used for scanning. Lower the scan resolution if possible. • Add optional page memory.
22-01	Memory overflow while receiving	<ul style="list-style-type: none"> • Wait for the files in the queue to be sent. • Delete unnecessary files from memory. • Transfer the substitute reception files to an another fax machine, if the machine's printer is busy or out of order. • Expand SAF memory.
22-02	Tx or rx job stalled due to line disconnection at the other end	<ul style="list-style-type: none"> • The job started normally but did not finish normally; data may or may not have been received fully. • Restart the machine.
22-04	The machine cannot store received data in the SAF	<ul style="list-style-type: none"> • Update the ROM • Replace the FCU.
23-00	Data read timeout during construction	<ul style="list-style-type: none"> • Restart the machine. • Replace the FCU
25-00	The machine software resets itself after a fatal transmission error occurred	<ul style="list-style-type: none"> • Update the ROM • Replace the FCU.
F0-xx	V.34 modem error	<ul style="list-style-type: none"> • Replace the FCU.

4.2 FAX SC CODES

4.2.1 OVERVIEW

If bit 7 of System Switch 1F is at the default setting, when the FCU detects a Fax SC Code condition other than SC1201, it resets itself automatically. This initializes the FCU without erasing files in the SAF memory or resetting the switches.

NOTE: For details on Fax SC Code 1201, refer to the following section.

If bit 7 of System Switch 1F is changed to “1”, when the FCU detects any Fax SC Code condition (not only SC1201), it displays the code on the display and stops working until the fax unit is initialized using one of the following methods:

- Hold down the “#” and “*” keys for more than 10 s.
- Turn off the main power switch and turn it back on.

The fax unit cannot make automatic service calls in reaction to a Fax SC Code, because the fax unit cannot make fax communications in fax SC Code conditions.

4.2.2 SC1201

When the FCU detects an unrecoverable error in the SRAM, which requires a complete SRAM initialization, the fax unit displays this SC Code and stops. There is no way to recover from this error condition without a complete SRAM initialization (all the user and service programmed data will be erased).

The possible causes are:

- SRAM backup battery defect, or TB3 on the FCU is at the “OFF” position
- SRAM on the FCU has a physical defect
- Flash memory card or data copy tool connection was loose

4.2.3 FAX SC CODE TABLE

SC Code	Description	Suggested Action	Sys Switch 1F bit 7 = 0	Sys Switch 1F bit 7 = 1
1102	Handshake error with BiCU at start-up	Initialize the fax unit. (See section 4.2.1. for the initialization procedure)	Automatic reset	SC Code display
1111	Command TX/RX error to/from the BiCU			
1112	Base copier's engine was reset			
1120	Interface module error			
1201	Unrecoverable FCU - SRAM error	Refer to section 4.2.2.	SC Code display	
1301	Original size error	Check the scanner mechanism.	Automatic reset	
1302	Scanner parameter error	Initialize the fax unit.		
1303	Software error	Initialize the fax unit.		
1304				
1305				
1306				
1308				
1313				
1314				
1316				
1318				
1323				
1324				
1326				
1328				
1334				
1338				
1401	Command timeout error - after scanning	Initialize the fax unit.		
1402	Software error	Initialize the fax unit.		
1403				
1404				
1405	Command timeout error - during storage	Check the connection for the FCU.		
1406	Command timeout error - original feed out	Initialize the fax unit.		
1410	Software error	Initialize the fax unit.		
1601				

4.3 FIRMWARE HISTORY

⇒ 4.3.1 B404 FAX OPTION FIRMWARE MODIFICATION HISTORY

B404X FAX OPTION FIRMWARE MODIFICATION HISTORY			
DESCRIPTION OF MODIFICATION	FIRMWARE LEVEL	SERIAL NUMBER	FIRMWARE VERSION
<ul style="list-style-type: none"> • 1st. mass Production 	B4045582 B	1 st . mass Production	01.12.00
<p>Corrects the following: When system switch 1E bit 2 (RTI/CSI display priority) = 1 (CSI), the machine displays “o” at the end of the other terminal’s CSI.</p> <ul style="list-style-type: none"> • e.g. +813123456789o • Titles are not listed in the Power Failure Report (e.g. File, Time, Mode). Please see related RTB# RB040002. • The colon (“:”) is not displayed between the switch number and bit string for User Parameter SW 18 onward 	B4045582 C	June 2001 Production	03.06.00
<ul style="list-style-type: none"> • The center mark is missing when printing out Quick Dial Labels. • The list print does not stop, even when the Clear/Stop key is pressed. • In some cases, part of the image data along the main scan direction is missing with A3→ B4 reduction Tx. • In some cases, Substitute Reception files do not appear on the Power Failure Report. 	B4045582 D	August 2001 Production	04.09.00
<ul style="list-style-type: none"> • The image in the area 3cm from the leading edge is sometimes printed again near the middle of the page. 	B4045582 E	October 2001 Production	05.01.00
•			
•			
•			

fax Unit b404

SERVICE TABLES

5. SERVICE TABLES

5.1 SERVICE LEVEL FUNCTIONS

5.1.1 HOW TO ENTER AND EXIT SERVICE MODE

To Enter Fax Service Mode:

1. Ensure that the machine is in standby mode.
2. Press (1) (0) (7), then hold down for more than 3 seconds.
The SP mode main menu appears.

```
[Service P-Mode] No._
1 Copy 2 Fax 3 Printer
```

3. Press (2) to enter the fax service mode.

```
SERVICE FUNCTION
■■ FUNCTION NO.
```

To Exit Fax Service Mode:

Press 'CANCEL' key to exit the service mode.

5.1.2 FUNCTION NO.

(1) 01. BIT SW

1. Enter the fax service mode.
2. Press , then 'OK'.
 - SYSTEM
 - SCANNER
 - PLOTTER
 - COMMUNI
 - G3

```
SERVICE FUNCTION
01.BIT SW ◀
```

```
0.SYSTEM 1.SCANNER
2.PLOTTER 3.COMMUNI.
```

Example

1. Press .
2. Scroll through the bit switches.
To increment the bit switch number:
Press '→'
To decrement the bit switch number:
Press '←'
3. Adjust the bit switch.
Example: To change the value of bit 7, press .
4. To adjust more bit switches, go to step 2.
To finish, press 'OK' then 'CANCEL'.
5. Exit the service mode.

```
SYS DF :0000 0000
BITSW 00:0000 0000
```

```
SYS DF :0000 0000
BITSW 00:1000 0000
```

SERVICE LEVEL FUNCTIONS

(2) 02. PARAMETER LIST

1. Enter the fax service mode.
2. Press .

```
SERVICE FUNCTION
02.PARAMETER LIST  ◀▶
```

3. Press 'OK'.
4. Press .

```
PARAMETER LIST  START
```

(3) 03. ERROR CODE

1. Enter the fax service mode.
2. Press .

```
SERVICE FUNCTION
03.ERROR CODE  ◀▶
```

3. Press 'OK'.
4. Scroll through the error codes with the arrow keys

```
ERROR CODE  ◀▶
00-00 JUN 04 22:07
```

(4) 04. SERVICE REPORT

1. Enter the fax service mode.
2. Press .

```
SERVICE FUNCTION
04.SERVICE REPORT  ◀▶
```

3. Press 'OK'.
4. Press .

```
SERVICE REPORT  START
```

(5) 05. PROTOCOL DUMP

1. Enter the fax service mode.
2. Press .
3. Press 'OK'.
4. Select '1-COMMUNICATION' or 'ALL-COMMUNICATIONS' with the arrow keys, then press 'OK'.
5. Press .

SERVICE FUNCTION
05.PROTOCOL DUMP

PROTOCOL DUMP
1-COMMUNICATION

PROTOCOL DUMP
ALL-COMMUNICATIONS

START
PROTOCOL DUMP

(6) 06. MEMORY

1. Enter the fax service mode.
 2. Press .
 3. Press 'OK'.
 4. Select 0 or 1.
- 0.-MEM.R/W:
Enter the RAM address and value.
- 1.-MEM.DUMP:
Enter the start address and end address.
Then press .

SERVICE FUNCTION
06.MEMORY

0.MEM.R/W 1.MEM.DUMP

MEMORY READ/WRITE
ADDR:680000 DATA:01

ADD.680000 - 6800FF
PRESS START TO PRINT

SERVICE LEVEL FUNCTIONS

(7) 07. RAM CLEAR

1. Enter the fax service mode.
2. Press .

SERVICE FUNCTION 07.RAM CLEAR	◀▶
----------------------------------	----

3. Press 'OK'.
4. Select 0, 1, 2, or 3. Then press .

0.INITIAL.	1.FILES
2.BITSW	3.FACTRY

0.–INITIAL:

Initializes the data in the SRAM, files in the SAF memory and the clock.

1.–FILES:

Erase all files stored in the SAF memory.

2.–BITSW:

Reset the bit switches and user parameters.

3.–FACTRY:

Initialize the data in the SRAM and files in the SAF memory.

(8) 08. NCU

1. Enter the fax service mode.
2. Press .

SERVICE FUNCTION 08.NCU	◀▶
----------------------------	----

3. Press 'OK'.
4. Select an item from the menu, then press .

0.NCU	1.MODEM
2.DTMF	3.V8

0.–NCU:

NCU parameters

1.–MODEM:

MODEM test

2.–DTMF:

DTMF test

3.–V8:

V8 test

4.–V34:

V34 test

5.–DP:

Dial pulse test

4.V34	5.DP
-------	------

(9) 09. ROM VERSION

1. Enter the fax service mode.
2. Press .

SERVICE FUNCTION
09.ROM VERSION ◀▶

3. Press 'OK'.
- The ROM version is displayed.

B4045584A 00-12-14
KIR-EUR Ver:01.02.00

(10) 10. FILE PRINTOUT

1. Enter the fax service mode.
2. Press .

SERVICE FUNCTION
10.FILE PRINTOUT ◀▶

3. Press 'OK'.
4. Press 'Start'. All files in the SAF are printed.

NO RECEPTION FILE(S)

Fax Unit B404

(11) 11. JOURNAL (ALL)

1. Enter the fax service mode.
2. Press .

SERVICE FUNCTION
11.JOURNAL(ALL) ◀▶

3. Press 'OK', then press .

JOURNAL(ALL) START

(15) 15. HISTORY

These functions are for designer use only. However, list 2 (Operation History) may be useful.

1. Enter the fax service mode.
2. Press .
3. Press 'OK'.
4. Press the number, then press .
02.-OPERATION HISTORY



SERVICE FUNCTION
15.HISTORY 



HISTORY
NO. 

5.2 DATA TRANSFER

5.2.1 FAX SOFTWARE DOWNLOAD

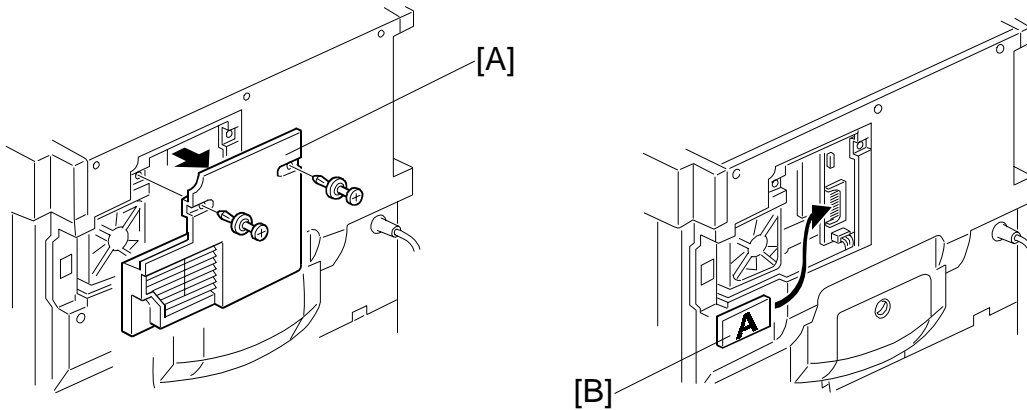

1. Turn off the main switch.
2. Remove the small rear cover [A].
3. Connect the IC card [B] that contains the firmware to the BiCU.
4. While holding the 'Tone' key down, turn on the main switch.
5. The machine goes to fax soft download mode automatically.

```
FAX Soft DownLoad  
Connecting...
```

```
FAX Soft DownLoad  
01.02.00->01.04.00 OK
```

6. Press 'OK'.

```
FAX Soft DownLoad  
Loading
```

```
FAX Soft DownLoad  
Writing
```

7. Turn off the main switch and disconnect the IC card.

If the download fails, an SC code (SC 695) appears. Retry the procedure.

```
FAX Soft DownLoad  
Completed
```

5.2.2 FAX SRAM DOWNLOAD

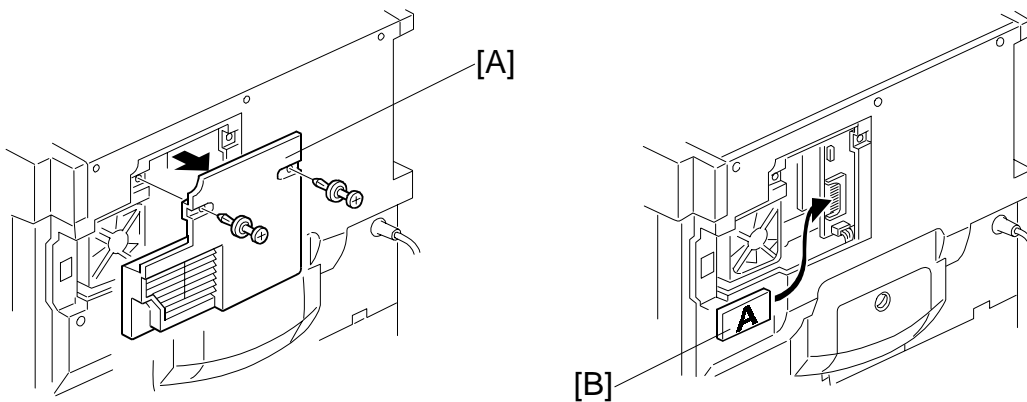

1. Turn off the main switch.
2. Remove the small rear cover [A].
3. Connect the IC card [B] that contains the required SRAM data to the BiCU.
4. While holding the 'Tone' key down, turn on the main switch.
5. Select "FAX SRAM Download" using the arrow key .

```
FAX SRAM DownLoad
                                     OK
```

6. Press 'OK'.

```
FAX SRAM DownLoad
Loading
```

```
FAX Soft DownLoad
Writing
```

7. Turn off the main switch and disconnect the IC card.

```
FAX SRAM DownLoad
Completed
```

5.2.3 FAX SRAM UPLOAD

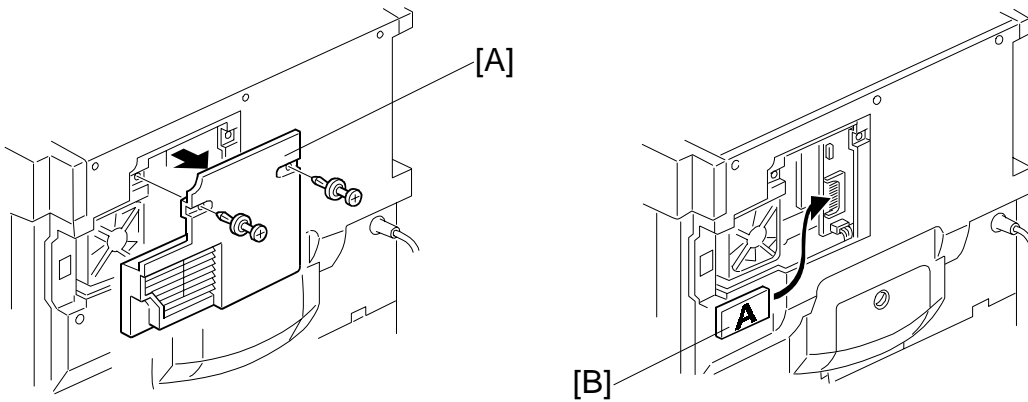

1. Turn off the main switch.
2. Remove the small rear cover [A].
3. Connect a blank IC card [B] to the BiCU.
4. While holding the 'Tone' key down, turn on the main switch.
5. Select "FAX SRAM Upload" using the arrow keys.
6. Press 'OK'.
7. Turn off the main switch and disconnect the IC card.

```
FAX SRAM UpLoad      OK
```

```
FAX SRAM UpLoad  
Loading
```

```
FAX SRAM UpLoad  
Writing
```

```
FAX SRAM UpLoad  
Completed
```

5.3 BIT SWITCHES

WARNING

Do not adjust a bit switch or use a setting that is described as “Not used”, as this may cause the machine to malfunction or to operate in a manner that is not accepted by local regulations. Such bits are for use only in other areas, such as Japan.

NOTE: Default settings for bit switches are not listed in this manual. Refer to the System Parameter List printed by the machine.

5.3.1 SYSTEM SWITCHES

System Switch 00		
No	FUNCTION	COMMENTS
0-1	Not used	Do not change the settings.
2	Technical data printout on the Journal 0: Disabled 1: Enabled	1: Instead of the personal name, the following data are listed on the Journal for each G3 communication. e.g. 0000 32V34 288/264 L01000304 (1) (2)(3) (4) (5) (6) (7)(8) (1): EQM value (Line quality data). The left hand figure is the high byte and the right hand figure is the low byte. A larger number means more errors. (2): Symbol rate (V.34 only) (3): Final modem type used (4): Starting data rate (for example, 288 means 28.8 kbps) (5): Final data rate (6): Rx level (refer to the note after this table for how to read the rx level) (7): Total number of error lines that occurred during non-ECM reception. (8): Total number of burst error lines that occurred during non-ECM reception. Note: EQM and rx level are fixed at "FFFF" in tx mode. The seventh and eighth numbers are fixed at "00" for transmission records and ECM reception records.
Rx level calculation Example: 0000 32 V34 288/264 L <u>01 00</u> 03 04 The four-digit hexadecimal value (N) after "L" indicates the rx level. The <u>high</u> byte is given first, followed by the <u>low</u> byte. Divide the decimal value of N by -16 to get the rx level. In the above example, the decimal value of N (= 0100 [H]) is 256. So, the actual rx level is 256/-16 = -16 dB		
3	Not used	Do not change the setting.
4	Line error mark on the received page 0: Disabled 1: Enabled	If this bit is 1, a mark will be printed on the left edge of the page at any place where a line error occurred in the data. Such errors are caused by a noisy line for example.

BIT SWITCHES

System Switch 00		
No	FUNCTION	COMMENTS
5	G3 communication parameter display 0: Disabled 1: Enabled	This is a fault-finding aid. The LCD shows the key parameters (see the next page). This is normally disabled because it cancels the CSI display for the user. Be sure to reset this bit to 0 after testing.
6	Protocol dump list output after each communication 0: Off 1: On	This is only used for communication troubleshooting. It shows the content of the transmitted facsimile protocol signals. Always reset this bit to 0 after finishing testing. The setting of system switch 09 bit 6 determines the types of communication that the list is printed after.
7	Not used	Do not change the setting.

G3 Communication Parameters

Modem rate	336: 33600 bps 168: 16800 bps 312: 31200 bps 144: 14400 bps 288: 28800 bps 120: 12000 bps 264: 26400 bps 96: 9600 bps 240: 24000 bps 72: 7200 bps 216: 21600 bps 48: 4800 bps 192: 19200 bps 24: 2400 bps
Resolution	S: Standard (8 x 3.85 dots/mm) D: Detail (8 x 7.7 dots/mm) F: Fine (8 x 15.4 dots/mm) 21: Standard (200 x 100 dpi) 22: Detail (200 x 200 dpi)
Compression mode	MMR: MMR compression MR: MR compression MH: MH compression
Communication mode	ECM: With ECM NML: With no ECM
Width and reduction	A4: A4 (8.3"), no reduction B4: B4 (10.1"), no reduction A3: A3 (11.7"), no reduction
I/O rate	0: 0 ms/line 10: 10 ms/line 25: 2.5 ms/line 20: 20 ms/line 5: 5 ms/line 40: 40 ms/line Note: "40" is displayed while receiving a fax message using AI short protocol.

BIT SWITCHES

System Switch 01 - Not used (Do not change the factory settings.)
--

System Switch 02		
No	FUNCTION	COMMENTS
0	SAF memory capacity 0: 2 MB 1: 4 MB	Before changing this bit, make sure that the remaining SAF memory is 100%. After changing this bit, be sure to turn off the machine and turn back it on again. When this bit set to 1, fine mode is not selectable.
1	Not used	Do not change the setting.
2	Communication stall failsafe 0: Disabled 1: Enabled	If enabled, the machine cuts the connection in one hour if a communication error has occurred but the connection is still established.
3-5	Not used	Do not change the settings.
6 7	Memory read/write by RDS Bit 7 6 Setting 0 0 Always disabled 0 1 User selectable 1 0 User selectable 1 1 Always enabled	(0,0): All RDS systems are always locked out. (0,1), (1,0): Normally, RDS systems are locked out, but the user can temporarily switch RDS on to allow RDS operations to take place. RDS will automatically be locked out again after a certain time, which is stored in System Switch 03. Note that if an RDS operation takes place, RDS will not switch off until this time limit has expired. (1,1): At any time, an RDS system can access the machine.

System Switch 03		
No	FUNCTION	COMMENTS
0 to 7	Length of time that RDS is temporarily switched on when bits 6 and 7 of System Switch 02 are set to "User selectable"	00 - 99 hours (BCD). This setting is only valid if bits 6 and 7 of System Switch 02 are set to "User selectable". The default setting is 24 hours.

System Switch 04		
No	FUNCTION	COMMENTS
0-2	Not used	Do not change the settings.
3	Printing dedicated tx parameters on Quick/Speed Dial Lists 0: Disabled 1: Enabled	1: Each Quick/Speed dial number on the list is printed with the dedicated tx parameters (8 bytes each). The last 10 bytes of data are the programmed dedicated tx parameters; 32 bytes of data are printed (the other 22 bytes have no use for service technicians).
4	Not used	Do not change the setting.
5	Memory file transfer operation 0: User level 1: Service level	If the machine is unable to print fax messages due to a mechanical problem, change this bit to 0 to transfer all messages in the memory (including confidential rx messages) to an another terminal. Always reset this bit to 1 after transfer. However, this bit can be left at 0, if the customer's key-operators want to transfer the files themselves. This machine does not support the confidential rx. Procedure 1. Enter service mode and change this bit to 0. 2. Exit the service mode. 3. Enter the key-operator mode, and select 'Key-operator settings'. 4. Choose '03' and specify a destination for the machine to transfer all the files to. 5. Press 'Start'. 6. After the machine transfers the memory files, enter the service mode and reset this bit to 1. Otherwise, anybody who knows how to enter the key-operator mode can transfer confidential messages.
6	G3 CSI/G4 Terminal ID programming level 0: User level 1: Service level	1: The CSI and Terminal ID can only be programmed by a technician (in the user tools). The Terminal ID can only be programmed if a Group 4 option is installed. This machine does not have a Group 4 option.
7	Telephone line type programming mode 0: User level 1: Service level	1: Telephone line type selection (choosing tone dial or pulse dial) can only be programmed by a technician (in the user tools).

Fax Unit B404

System Switch 05		
No	FUNCTION	COMMENTS
0-1	Not used	Do not change the settings.
2	Display of both RTI and CSI on the LCD 0: Disabled 1: Enabled	1: An RTI will be displayed until phase B of the protocol sequence, and a CSI will be displayed after phase C.
3-7	Not used	Do not change the settings.

BIT SWITCHES

System Switch 06 - Not used (Do not change the factory settings.)
System Switch 07 - Not used (Do not change the factory settings.)
System Switch 08 - Not used (Do not change the factory settings.)

System Switch 09		
No	FUNCTION	COMMENTS
0	Not used	Do not change the setting.
1	Inclusion of communications on the Journal when no image data was exchanged. 0: Disabled 1: Enabled	0: Communications that reached phase C (message tx/rx) of the T.30 protocol are listed on the Journal. 1: Communications that reached phase A (call setup) of T.30 protocol are listed on the Journal. This will include telephone calls.
2	Automatic error report printout 0: Disabled 1: Enabled	0: Error reports will not be printed. 1: Error reports will be printed automatically after failed communications.
3	Printing of the error code on the error report 0: No 1: Yes	1: Error codes are printed on the error reports.
4	Not used	Do not change the setting.
5	Power failure report 0: Disabled 1: Enabled	1: A power failure report will be automatically printed after the power is switched on if a fax message disappeared from the memory when the power was turned off last.
6	Conditions for printing the protocol dump list 0: Print for all communications 1: Print only when there is a communication error	This switch becomes effective only when system switch 00 bit 6 is set to 1. 1: Set this bit to 1 when you wish to print a protocol dump list only for communications with errors.
7	Priority given to various types of remote terminal ID when printing reports 0: RTI > CSI > Dial label > Tel. number 1: Dial label > Tel. number > RTI > CSI	This bit determines which set of priorities the machine uses when listing remote terminal names on reports. In G4 communication, G4_TID (Terminal ID) is used instead of RTI or CSI. Dial Label: The name stored, by the user, for the Quick/Speed Dial number. This machine does not have a Group 4 option.

System Switch 0A		
No	FUNCTION	COMMENTS
0-3	Not used	Do not change the settings.
4	Dialing on the ten-key pad when the external telephone is off-hook 0: Disabled 1: Enabled	0: Prevents dialing from the ten-key pad while the external telephone is off-hook. Use this setting when the external telephone is not by the machine, or if a wireless telephone is connected as an external telephone. 1: The user can dial on the machine's ten-key pad when the handset is off-hook.
5	On hook dial 0: Disabled 1: Enabled	0: On hook dial is disabled.
6-7	Not used	Do not change the settings.

System Switch 0B - Not used (Do not change the factory settings.)
System Switch 0C - Not used (Do not change the factory settings.)
System Switch 0D - Not used (Do not change the factory settings.)

System Switch 0E		
No	FUNCTION	COMMENTS
0-2	Not used	Do not change the settings.
3	Action when the external handset goes off-hook 0: Manual tx and rx operation 1: Memory tx and rx operation (the display remains the same)	0: Manual tx and rx are possible while the external handset is off-hook. But, memory tx is not possible. 1: The display stays in standby mode even when the external handset is used, so that other people can use the machine for memory tx operation. Note that manual tx and rx are not possible with this setting.
4-7	Not used	Do not change the settings.

BIT SWITCHES

System Switch 0F		
No	FUNCTION	COMMENTS
0 to 7	Country code for functional settings (Hex) 00: France 11: USA 01: Germany 12: Asia 02: UK 13: Japan 03: Italy 14: Hong Kong 04: Austria 15: South Africa 05: Belgium 16: Australia 06: Denmark 17: New Zealand 07: Finland 18: Singapore 08: Ireland 19: Malaysia 09: Norway 1A: China 0A: Sweden 1B: Taiwan 0B: Switz. 1C: Korea 0C: Portugal 20: Turkey 0D: Holland 21: Greece 0E: Spain 22: Hungary 0F: Israel 23: Czech 10: Not used 24: Poland	This country code determines the factory settings of bit switches and RAM addresses. However, it has no effect on the NCU parameter settings and communication parameter RAM addresses. Cross reference NCU country code: Function 08, parameter C.C.

System Switch 10		
No	FUNCTION	COMMENTS
0 to 7	Threshold memory level for parallel memory transmission	Threshold = N x 128 kbytes + 256 kbytes N can be between 00 - FF(H) Default setting: 02(H) = 512 kbytes

System Switch 11		
No	FUNCTION	COMMENTS
0	TTI printing position 0 : Superimposed on the page data 1 : Printed before the data leading edge	Change this bit to 1 if the TTI overprints information that the customer considers to be important (G3 transmissions).
1-7	Not used	Do not change the settings.

System Switch 12		
No	FUNCTION	COMMENTS
0 to 7	TTI printing position in the main scan direction	TTI/CIL: 08 to 64 (BCD) mm Input even numbers only. This setting determines the print start position for the TTI and CIL from the left edge of the paper. If the TTI is moved too far to the right, it may overwrite the file number which is on the top right of the page. This machine does not have a Group 4 option.

System Switch 13 - Not used (do not change the settings)
System Switch 14 - Not used (do not change the settings)

System Switch 15		
No	FUNCTION	COMMENTS
0	Not used	Do not change the settings.
1	Going into the Sleep mode automatically 0: Enabled 1: Disabled	1: The machine will restart from the Energy Saver mode quickly, because the +5V power supply is active even in the Energy Saver mode.
2	Protocol dump data backup 0: Disabled 1: Enabled	1: The machine backs up the protocol dump data for approximately one hour when the main switch is turned off, in the same way as image data.
3-7	Not used	Do not change the settings.

System Switch 16 - Not used (do not change the settings)

System Switch 17		
No	FUNCTION	COMMENTS
1-5	Not used	Do not change the settings.
6	Memory Lock function 0: Disabled 1: Enabled	Change this bit to "1" when the customer requests.
7	Not used	Do not change the setting.

System Switch 18 - Not used (do not change the settings)

System Switch 19		
No	FUNCTION	COMMENTS
0-6	Not used	Do not change the setting.
7	Special Original mode 0: Disabled 1: Enabled	1: If the customer frequently wishes to transmit a form or letterhead which has a colored or printed background, change this bit to "1". "Special Original" can be selected in addition to the "Text" and "Photo" modes. When this mode is selected, the "Text" and "Photo" LEDs are both lit. Cross reference <input type="checkbox"/> Type of special original mode – Scanner switch 00 bit 0.

BIT SWITCHES

System Switch 1A - Not used (do not change the settings)
System Switch 1B - Not used (do not change the settings)
System Switch 1C - Not used (do not change the settings)

System Switch 1D		
No	FUNCTION	COMMENTS
0	RTI/CSI display during communication 0: Enabled 1: Disabled	If enabled, the machine displays the RTI/CSI on the LCD panel during communication.
1-7	Not used	Do not change the settings.

System Switch 1E		
No	FUNCTION	COMMENTS
0	Communication after the Journal data storage area has become full 0: Possible 1: Impossible	This setting is effective only when Automatic Journal printout is enabled. 0: If the buffer memory of the communication records for the Journal is full, fax communications are still possible. But the machine will overwrite the oldest communication records. 1: If the buffer memory of the communication records for the Journal has become full, fax communications will become impossible, to prevent overwriting the communication records before the machine prints them out. Cross Reference <input type="checkbox"/> Automatic Journal output - User switch 03 bit 7 <input type="checkbox"/> Number of communication records for the Journal: 100 records
1	Action when the SAF memory has become full during scanning 0: The current page is erased. 1: The entire file is erased.	0: If the SAF memory becomes full during scanning, the successfully scanned pages are transmitted. 1: If the SAF memory becomes full during scanning, the file is erased and no pages are transmitted. Not applicable to parallel memory transmission
2	RTI/CSI display priority 0: RTI 1: CSI	This bit determines which identifier, RTI or CSI, is displayed on the LCD while the machine is communicating in G3 non-standard mode.
3	Not used	Do not change the setting.
4	Action when authorized reception is enabled but authorized RTIs/CSIs are not yet programmed: 0: All fax reception is disabled 1: Faxes can be received if the sender has an RTI or CSI	This determines how the machine behaves if authorized reception is enabled but the user has stored no acceptable sender RTIs or CSIs. 0: The machine will not be able to receive any fax messages. 1: Messages from senders that include an RTI or CSI will be received.

System Switch 1E		
No	FUNCTION	COMMENTS
5	Address display priority in the AI redial mode. 0: RTI/CSI 1: Telephone number	0: When the machine has both RTI/CSI and the telephone number information, the machine displays RTI/CSI. 1: The machine always displays the telephone number.
6-7	Not used	Do not change the settings.

System Switch 1F		
No	FUNCTION	COMMENTS
0	Not used	Do not change the settings.
1	Report printout after an original jam during SAF storage or if the SAF memory fills up 0: Enabled 1: Disabled	0: When an original jams, or the SAF memory overflows during scanning, a report will be printed. Change this bit to "1" if the customer does not want to have a report in these cases. Memory tx – Memory storage report Parallel memory tx – Transmission result report
2	Not used	Do not change the settings.
3	Received fax print start timing (G3 reception) 0: After receiving each page 1: After receiving all pages	0: The machine prints each page immediately after the machine receives it. 1: The machine prints the complete message after the machine receives all the pages in the memory.
4-6	Not used	Do not change the factory settings.
7	Action when a fax SC has occurred 0: Automatic reset 1: SC code display	0: When the fax unit detects a fax SC code other than SC1201, the fax unit automatically resets itself. 1: When the fax unit detects any fax SC code, the fax unit displays the SC code and stops. Cross Reference Fax SC codes - See "Troubleshooting"

Fax Unit B404

5.3.2 SCANNER SWITCHES

Scanner Switch 00		
No	FUNCTION	COMMENTS
0	Type of special original mode 0: Monotone background 1: Colored background	This setting determines the scanner parameters used for special original mode. 0: This setting is for originals with random background of constant density, such as seen on banknotes (faxing banknotes is not recommended!). 1: This setting is for originals with background of constant density, such as those made on coloured paper. This switch becomes effective only when system switch 19 bit 7 is set to 1.
1-6	Not used	Do not change the settings.
7	Photo mode operation 0: Photo mode 1: Text/Photo mode	This determines how photo mode actually operates. If 0 is selected it will operate the same as photo mode. This only affects scanning in fax mode.

Scanner Switch 01		
No	FUNCTION	COMMENTS
0 to 5	Scan density step value (Text mode)	When scan density is adjusted manually away from the Normal setting, the threshold value for binary picture processing changes for each step from the value specified by Scanner Switch 02, by the amount programmed here. For example, with the default setting (05), the threshold value changes as follows. +2 (Darkest) : 20 (= 25 - 5) +1 : 25 (= 30 - 5) 0 (Normal) : 30 (Scanner Switch 02 setting) -1 : 35 (= 30 + 5) -2 (Lightest) : 40 (= 35 + 5) The value can be between 00 and 3F(H) [= 63 (D)]. For a darker threshold, input a lower value.
6-7	Not used.	Do not change the settings.

Scanner Switch 02		
No	FUNCTION	COMMENTS
0 to 5	Binary picture processing: Threshold for Text mode - Normal setting (center position)	This setting determines the threshold value for binary picture processing in Text mode (when the scan density setting is at the center). The value can be between 01 and 3F. For a darker threshold, input a lower value. Default setting: 1E (H) = 30 (D)
6-7	Not used.	Do not change the settings.

Scanner Switch 03 - Not used (do not change the settings)
Scanner Switch 04 - Not used (do not change the settings)
Scanner Switch 05 - Not used (do not change the settings)

Scanner Switch 06		
No	FUNCTION	COMMENTS
0 to 3	MTF filter level (Text mode) The value can be between 0 (Off) and F. For a weaker threshold, input a lower value. Default setting: 7	This setting is independent from the threshold specified by copier SP mode.
4 to 7	MTF filter level (Photo mode) The value can be between 0 (Off) and F. For a weaker threshold, input a lower value. Default setting: 7	This setting is independent from the threshold specified by copier SP mode. This affects only when bit7 = 1 of scanner switch 00 and select the photo mode.

Scanner Switch 07		
No	FUNCTION	COMMENTS
0 to 2	Smoothing filter level (Photo mode)	The value can be between 0 (Off) and 7. For a weaker threshold, input a lower value. Default setting: 2 This setting is independent from the threshold setting specified by the copier's SP mode. This affects only when bit7 = 0 of scanner switch 00 and select the photo mode..
3	Not used	Do not change the settings.
4-6	White line erase	Select the strength for the white line erase function. The value can be between 0 (Off) and 5. For a weaker level, input a lower value. This affects only when text/photo mode is selected.
7	Not used	Do not change the settings.

Scanner Switch 08 - Not used (do not change the settings)
Scanner Switch 09 - Not used (do not change the settings)
Scanner Switch 0A - Not used (do not change the settings)

Scanner Switch 0B		
No	FUNCTION	COMMENTS
0 to 3	Scan margin setting (right and left margin in book scan and in ADF mode) The setting can be between 0 and F (H) (unit 0.5 mm).	
4 to 7	Scan margin setting (Top and bottom margin in book scan and in ADF mode) The setting can be between 0 and F (H) (unit 0.5 mm).	

BIT SWITCHES

Scanner Switch 0C		
No	FUNCTION	COMMENTS
0	<p>Action when an original jam has occurred while scanning the original into memory for memory tx</p> <p>0: Continues scanning after recovery</p> <p>1: Stops scanning and erases all scanned pages for that job</p>	<p>This bit is only effective when parallel memory tx is disabled (user parameter 07 - bit 2). If parallel memory tx is enabled, the machine always erases the scanned pages when an original jam occurs. The machine then asks the user to retry from the first page, even if parallel memory tx is not actually used.</p> <p>0: The machine displays a message asking the user to put the jammed page back into the original stack, and continues scanning. The message is displayed for the time period specified by scanner switch 0E, bit 2.</p> <p>1: The machine erases all the scanned pages and asks the user to retry from the first page.</p>
1 to 2	<p>Setting when an original size cannot be recognized</p> <p>Bit 2 1 Setting</p> <p>0 0 Depending on the copier's setting</p> <p>0 1 A5/HLT □ (LEF)</p> <p>1 0 A5/HLT □ (SEF)</p> <p>1 1 No original</p>	<p>When both bits are set to "0", the machine recognizes an original size depending on copier's service mode.</p>
3-5	Not used	Do not change the settings.
6	<p>Scan width used for a document set in the ADF when the width is less than 230 mm.</p> <p>0: A4 (210 mm),</p> <p>1: LT (216 mm)</p>	<p>This bit is set at "1" when the country code is set to the US.</p>
7	Not used	Do not change the setting.

Scanner Switch 0D		
No	FUNCTION	COMMENTS
0 1	Scan magnification ratio fine tuning (Main scan direction) $\begin{pmatrix} 0 \\ 0 \end{pmatrix} = 0\%, \begin{pmatrix} 1 \\ 0 \end{pmatrix} = -1.5\%, \begin{pmatrix} 0 \\ 1 \end{pmatrix} = +1.5\%, \begin{pmatrix} 1 \\ 1 \end{pmatrix} =$ Do not use this setting The actual magnification ratio is the sum of the SP mode setting of copier and this setting.	
2 3	Scan magnification ratio fine tuning (Sub scan direction) $\begin{pmatrix} 0 \\ 0 \end{pmatrix} = 0\%, \begin{pmatrix} 1 \\ 0 \end{pmatrix} = -1.5\%, \begin{pmatrix} 0 \\ 1 \end{pmatrix} = +1.5\%, \begin{pmatrix} 1 \\ 1 \end{pmatrix} =$ Do not use this setting The actual magnification ratio is the sum of the SP mode setting of copier and this setting.	
4-6	Not used	Do not change the settings.
7	Scan width for A5 SEF or B5 SEF originals 0: 210 mm (8.5") 1: Original width	0: The machine scans the original as 210 mm (8.5") width. The transmitted image has a blank area on the right. 1: The machine scans 148 mm (A5) or 182 mm (B5) and centers the scanned data on a 216 mm width transmitted image.

Scanner Switch 0E		
No	FUNCTION	COMMENTS
0	Wait time for the next page when scanning a book original into memory 0: 60 s 1: 30 s	This bit determines how long the machine waits for the next page when scanning a book original for memory transmission. If this timer expires, the machine transmits all the pages scanned so far as one document. Note: For immediate tx or parallel memory tx, the wait time for the next page is 10 s.
1	Scan resolution unit (except standard resolution in book scan mode) 0: mm 1: inches	This bit determines which resolution unit will be used for scanning a fax message. Default setting: mm
2	ADF jam alarm display time 0: 60 s 1: 30 s	The bit is only effective when bit 0 of scanner bit switch 0C is '0'. This bit determines how long the machine displays the ADF jam alarm after a jam occurred.
3-7	Not used	Do not change the settings.

BIT SWITCHES

Scanner Switch 0F		
No	FUNCTION	COMMENTS
0	Image rotation before transmission (A4/LT LEF) 0: Disabled 1: Enabled	This bit determines whether the machine rotates the scanned image by 90 degrees before transmission. If this bit is set at 1, A4 (LT) LEF images (297 mm width in the protocol) will be transmitted as A4 (LT) SEF images (216 mm width in the protocol).
1	Not used	Do not change the setting.
2	Image rotation before transmission (A5/HLT SEF) 0: Disabled 1: Enabled	This bit determines whether the machine rotates the scanned image by 90 degrees before transmission. If this bit is set at "1", A5 (HLT) SEF images will be transmitted as A4 (LT) width images (216 mm width in the protocol).
3-7	Not used	Do not change the settings.

5.3.3 PLOTTER SWITCHES

Plotter Switch 00		
No	FUNCTION	COMMENTS
0	Page separation mark 0: Disabled 1: Enabled	0: No marks are printed. 1: If a received page has to be printed out on two sheets, an asterisk inside square brackets is printed at the bottom right hand corner of the first sheet, and a "2" inside a small box is printed at the top right hand corner of the second sheet. This helps the user to identify pages that have been split.
1	Repetition of data when the received page is longer than the printer paper 0: Disabled 1: Enabled	0: The next page continues from where the previous page left off. 1: The final few mm of the previous page are repeated at the top of the next page. The amount of repeated data depends on plotter switch 04, bits 5 and 6.
2	Prints the date and time on received fax messages 0: Disabled 1: Enabled	This switch is only effective when user parameter 02 - bit 2 (printing the received date and time on received fax messages) is enabled. 1: The machine prints the received and printed date and time at the bottom of each received page.
3-7	Not used	Do not change the settings.

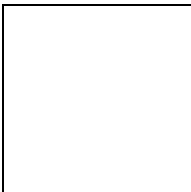
Plotter Switch 01		
No	FUNCTION	COMMENTS
0-2	Not used	Do not change the settings.
3 4	Maximum print width used in the setup protocol 	
5-6	Not used	Do not change the settings.
7	Received message width restriction in the protocol signal to the sender 0: Disabled 1: Enabled	0: The machine informs the transmitting machine of the print width depending on the paper size available from the paper feed stations. Refer to the table on the next page for how the machine chooses the paper width used in the setup protocol (NSF/DIS). 1: The machine informs the transmitting machine of the fixed paper width which is specified by bits 3 and 4 above.

BIT SWITCHES

Relationship between available paper sizes and printer width used in the setup protocol

Available Paper Size	Printer width used in the Protocol (NSF/DIS)
A4 or 8.5 x 11"	297 mm width
B5	256 mm width
A5 or 8.5 x 5.5"	216 mm width
No paper available (Paper end)	216 mm width

Plotter Switch 02		
No	FUNCTION	COMMENTS
0	1st paper feed station usage for fax printing 0: Enabled 1: Disabled	0: The paper feed station can be used to print fax messages and reports. 1: The specified paper feed station will not be used for printing fax messages and reports. Note: Do not disable usage for the paper feed station which has been specified by User Parameter Switch 0F (15), or which is used for the Specified Cassette Selection feature.
1	2nd paper feed station usage for fax printing 0: Enabled 1: Disabled	
2	3rd paper feed station usage for fax printing 0: Enabled 1: Disabled	
3	4th paper feed station usage for fax printing 0: Enabled 1: Disabled	
4-7	Not used	Do not change the settings.

Plotter Switch 03		
No	FUNCTION	COMMENTS
0	Length reduction of received data 0: Disabled 1: Enabled	0: Incoming pages are printed without length reduction. (Page separation threshold: Plotter Switch 03, bits 4 to 7) 1: Incoming page length is reduced when printing. (Maximum reducible length: Plotter Switch 04, bits 0 to 4)
1-3	Not used	
		Do not change the settings.

Plotter Switch 03											
4 to 7	<p>Page separation threshold (with reduction disabled with switch 03-0 above)</p> <p>If the incoming page is up to x mm longer than the length of copy paper, the excess portion will not be printed. If the incoming page is more than x mm longer than the length of copy paper, the excess portion will be printed on the next page. The value of x is determined by these four bits.</p> <table style="margin-left: 20px;"> <tr> <td>Hex value of bits 4 to 7</td> <td>x (mm)</td> </tr> <tr> <td>0</td> <td>0</td> </tr> <tr> <td>1</td> <td>1</td> </tr> <tr> <td>and so on until</td> <td></td> </tr> <tr> <td>F</td> <td>15</td> </tr> </table> <p>Default setting: 6 mm</p> <p>Cross reference Length reduction On/Off: Printer Switch 03, Bit 0</p>	Hex value of bits 4 to 7	x (mm)	0	0	1	1	and so on until		F	15
Hex value of bits 4 to 7	x (mm)										
0	0										
1	1										
and so on until											
F	15										

Plotter Switch 04																																					
No	FUNCTION	COMMENTS																																			
0 to 4	<p>Maximum reducible length when length reduction is enabled with switch 03-0 above. <Maximum reducible length> = <Paper length> + (N x 5mm) 'N' is the decimal value of the binary setting of bits 0 to 4.</p> <table style="margin-left: 20px;"> <tr> <td>Bit</td> <td>4</td> <td>3</td> <td>2</td> <td>1</td> <td>0</td> <td>Setting</td> </tr> <tr> <td></td> <td>0</td> <td>0</td> <td>0</td> <td>0</td> <td>0</td> <td>0 mm</td> </tr> <tr> <td></td> <td>0</td> <td>0</td> <td>0</td> <td>0</td> <td>1</td> <td>5 mm</td> </tr> <tr> <td></td> <td>0</td> <td>0</td> <td>1</td> <td>0</td> <td>0</td> <td>20 mm (default setting)</td> </tr> <tr> <td></td> <td>1</td> <td>1</td> <td>1</td> <td>1</td> <td>1</td> <td>155 mm</td> </tr> </table> <p>For A5 sideways and B5 sideways paper <Maximum reducible length> = <Paper length> + 0.75 x (N x 5mm)</p>	Bit	4	3	2	1	0	Setting		0	0	0	0	0	0 mm		0	0	0	0	1	5 mm		0	0	1	0	0	20 mm (default setting)		1	1	1	1	1	155 mm	
Bit	4	3	2	1	0	Setting																															
	0	0	0	0	0	0 mm																															
	0	0	0	0	1	5 mm																															
	0	0	1	0	0	20 mm (default setting)																															
	1	1	1	1	1	155 mm																															
5 to 6	<p>Length of the duplicated image on the next page, when page separation has taken place.</p> <p>$\begin{pmatrix} 0 \\ 0 \end{pmatrix} = 4\text{ mm}$ $\begin{pmatrix} 1 \\ 0 \end{pmatrix} = 10\text{ mm}$ $\begin{pmatrix} 0 \\ 1 \end{pmatrix} = 15\text{ mm}$ $\begin{pmatrix} 1 \\ 1 \end{pmatrix} = \text{Not used}$</p>																																				
7	Not used.	Do not change the setting.																																			

Plotter Switch 05 - Not used (do not change the settings)

BIT SWITCHES

Plotter Switch 06		
No	FUNCTION	COMMENTS
0	Printing while a paper cassette is pulled out, when the Just Size Printing feature is enabled. 0: Printing will not start 1: Printing will start if another cassette has a suitable size of paper, based on the paper size selection priority tables.	Cross reference Just size printing on/off – User switch 05, bit 5
1-7	Not used.	Do not change the settings.

Plotter Switch 07		
No	FUNCTION	COMMENTS
0-3	Not used.	Do not change the settings.
4	List of destinations in the Communication Failure Report for broadcasting 0: All destinations 1: Only destinations where communication failure occurred	1: Only destinations where communication failure occurred are printed on the Communication Failure Report.
5-7	Not used.	Do not change the settings.

Plotter Switch 08 - Not used (do not change the settings)
Plotter Switch 09 - Not used (do not change the settings)
Plotter Switch 0A - Not used (do not change the settings)
Plotter Switch 0B - Not used (do not change the settings)
Plotter Switch 0C - Not used (do not change the settings)
Plotter Switch 0D - Not used (do not change the settings)

Plotter Switch 0E		
No	FUNCTION	COMMENTS
0	Paper size selection priority 0: Width 1: Length	0: A paper size that has the same width as the received data is selected first. 1: A paper size which has enough length to print all the received lines without reduction is selected first.
1	Paper size selected for printing A4 width fax data 0: 8 x 11" size 1: A4 size	This switch determines which paper size is selected for printing A4 width fax data, when the machine has both A4 and 8" x 11" size paper.

Plotter Switch 0E		
2	Page separation 0: Enabled 1: Disabled	1: If all paper sizes in the machine require page separation to print a received fax message, the machine does not print the message (Substitute Reception is used). After a larger size of paper is set in a cassette, the machine automatically prints the fax message.
3 to 4	Printing the sample image on reports Bit 4 Bit 3 Setting 0 0 The upper half only 0 1 50% reduction in sub-scan only 1 0 Same size 1 1 Not used	“Same size” means the sample image is printed at 100%, even if page separation occurs. User Parameter Switch 19 bit 4 must be set to “0” to enable this switch.
5-6	Not used	Do not change the settings.
7	Equalizing the reduction ratio among separated pages (Page Separation) 0: Enabled 1: Disabled	0: When page separation has taken place, all the pages are reduced with the same reduction ratio. 1: Only the last page is reduced to fit the selected paper size when page separation has taken place. Other pages are printed without reduction.

Plotter Switch 0F		
No	FUNCTION	COMMENTS
0 to 1	Smoothing for received fax images Bit 1 Bit 0 Setting 0 0 Disabled 0 1 Disabled if the sender used halftone 1 0 Enabled 1 1 Not used	(0, 0): Smoothing is always disabled. (0, 1): Smoothing is disabled only when half-tone mode was selected by the transmitting side.
2-3	Not used	Do not change the settings.
4	Printing fax messages in user code mode. 0: Enabled 1: Disabled	1: The machine holds the received fax messages until the machine exits the restricted access mode (user code or key counter). If the machine enters the restricted access mode again while printing fax messages, it stops printing until it exits the mode again.
5-7	Not used	Do not change the settings.

BIT SWITCHES

5.3.4 COMMUNICATION SWITCHES

Communication Switch 00		
No	FUNCTION	COMMENTS
0 to 1	Compression modes available in receive mode Bit 1 0 Modes 0 0 MH only 0 1 MH/MR 1 0 MH/MR/MMR 1 1 MH/MR/MMR/JBIG	These bits determine the compression capabilities to be declared in phase B (handshaking) of the T.30 protocol. (1, 1): Not used in this machine, because it does not support JBIG.
2 to 3	Compression modes available in transmit mode Bit 3 2 Modes 0 0 MH only 0 1 MH/MR 1 0 MH/MR/MMR 1 1 MH/MR/MMR/JBIG	These bits determine the compression capabilities to be used in the transmission and to be declared in phase B (handshaking) of the T.30 protocol. (1, 1): Not used in this machine, because it does not support JBIG.
4-7	Not used	Do not change the settings.

Communication Switch 01		
No	FUNCTION	COMMENTS
0	ECM 0: Off 1: On	If this bit is set to 0, ECM is switched off for all communications. In addition, V.8 protocol and JBIG compression are switched off automatically. JBIG is not used in this machine.
1	Not used	Do not change the setting.
2 to 3	Wrong connection prevention method Bit 3 Bit 2 Setting 0 0 None 0 1 8 digit CSI 1 0 4 digit CSI 1 1 CSI/RTI	(0,1) - The machine will disconnect the line without sending a fax message if the last 8 digits of the received CSI do not match the last 8 digits of the dialed telephone number. This does not work when manually dialed. (1,0) - The same as above, except that only the last 4 digits are compared. (1,1) - The machine will disconnect the line without sending a fax message, if the other end does not identify itself with an RTI or CSI. (0,0) - Nothing is checked; transmission will always go ahead. Note: This function does not work when dialing is done from the external telephone.
4-5	Not used	Do not change the setting.

Communication Switch 01		
No	FUNCTION	COMMENTS
6 7	Maximum printable page length available Bit 7 6 Setting 0 0 No limit 0 1 B4 (364 mm) 1 0 A4 (297 mm) 1 1 A3 (432 mm)	The setting determined by these bits is informed to the transmitting terminal in the pre-message protocol exchange (in the DIS/NSF frames).

Communication Switch 02		
No	FUNCTION	COMMENTS
0	Burst error threshold 0: Low 1: High	If there are more consecutive error lines in the received page than the threshold, the machine will send a negative response. The Low and High threshold values depend on the sub-scan resolution, and are as follows. Resolution 100 dpi 200 dpi 400 dpi 3.85 l/mm 7.7 l/mm 15.4 l/mm Low settings 6 12 24 High settings 12 24 48
1	Acceptable total error line ratio 0: 5% 1: 10%	If the error line ratio for a page exceeds the acceptable ratio, RTN will be sent to the other end.
2	Treatment of pages received with errors during G3 reception 0: Deleted from memory without printing 1: Printed	0: Pages received with errors are not printed.
3	Hang-up decision when a negative code (RTN or PIN) is received during G3 immediate transmission 0: No hang-up, 1: Hang-up	0: The next page will be sent even if RTN or PIN is received. 1: The machine will send DCN and hang up if it receives RTN or PIN. This bit is ignored for memory transmissions or if ECM is being used.
4-5	Mistaken Auto Service Call prevention Bit 3 Bit 2 Setting 0 0 None 0 1 8 digit CSI 1 0 4 digit CSI 1 1 CSI/RTI	(0,1) - The machine will disconnect the line without sending a fax message if the last 8 digits of the received CSI do not match the last 8 digits of the dialed telephone number. This does not work when manually dialed. (1,0) - The same as above, except that only the last 4 digits are compared. (1,1) - The machine will disconnect the line without sending a fax message, if the other end does not identify itself with an RTI or CSI. (0,0) - Nothing is checked; transmission will always go ahead.
6-7	Not used	Do not change the settings.

BIT SWITCHES

Communication Switch 03		
No	FUNCTION	COMMENTS
0 to 7	Maximum number of page retransmissions in a G3 memory transmission	00 - FF (Hex) times. This setting is not used if ECM is switched on. Default setting - 03(H)

Communication Switch 04 - Not used (do not change the settings)
Communication Switch 05 - Not used (do not change the settings)
Communication Switch 06 - Not used (do not change the settings)
Communication Switch 07 - Not used (do not change the settings)
Communication Switch 08 - Not used (do not change the settings)
Communication Switch 09 - Not used (do not change the settings)

Communication Switch 0A		
No	FUNCTION	COMMENTS
0	Point of resumption of memory transmission upon redialing 0: From the error page 1: From page 1	0: The transmission begins from the page where transmission failed the previous time. 1: Transmission begins from the first page, using normal memory transmission.
1-7	Not used	Do not change the settings.

Communication Switch 0B - Not used (do not change the settings)
Communication Switch 0C - Not used (do not change the settings)

Communication Switch 0D		
No	FUNCTION	COMMENTS
0 to 7	The available memory threshold, below which ringing detection (and therefore reception into memory) is disabled	00 to FF (Hex), unit = 4 kbytes (e.g., 06(H) = 24 kbytes) One page is about 24 kbytes. The machine refers to this setting before each fax reception. If the amount of remaining memory is below this threshold, the machine cannot receive any fax messages. If this setting is kept at 0, the machine will detect ringing signals and go into receive mode even if there is no memory available. This will result in communication failure.

Communication Switch 0E		
No	FUNCTION	COMMENTS
0 to 7	Minimum interval between automatic dialing attempts	06 to FF (Hex), unit = 2 s (e.g., 06(H) = 12 s) This value is the minimum time that the machine waits before it dials the next destination.

Communication Switch 0F - Not used (do not change the settings)

Communication Switch 10		
No	FUNCTION	COMMENTS
0 to 7	Memory transmission: Maximum number of dialing attempts to the same destination	01 - FE (Hex) times

Communication Switch 11 - Not used (do not change the settings.)

Communication Switch 12		
No	FUNCTION	COMMENTS
0 to 7	Memory transmission: Interval between dialing attempts to the same destination	01 - FF (Hex) minutes

Communication Switch 13 - Not used (do not change the settings.)

Communication Switch 14			
No	FUNCTION		COMMENTS
0	Inch-to-mm conversion during transmission 0: Disabled 1: Enabled		<p>0: In immediate transmission, data scanned in inch format are transmitted without conversion. In memory transmission, data stored in the SAF memory in mm format are transmitted without conversion.</p> <p>Note: When storing the scanned data into SAF memory, the fax unit always converts the data into mm format.</p> <p>1: The machine converts the scanned data or stored data in the SAF memory to the format which was specified in the set-up protocol (DIS/NSF) before transmission.</p>
1-5	Not used		Do not change the factory settings.
6 to 7	Available unit of resolution in which fax messages are received		For the best performance, do not change the factory settings.
	Bit 7	Bit 6 Unit	The setting determined by these bits is informed to the transmitting terminal in the pre-message protocol exchange (in the DIS/NSF frames).
	0	0 mm	
	0	1 inch	
	1	0 mm and inch (default)	
	1	1 Not used	

BIT SWITCHES

Communication Switch 15 - Not used (do not change the settings)
Communication Switch 16 - Not used (do not change the settings)
Communication Switch 17 - Not used (do not change the settings)
Communication Switch 18 - Not used (do not change the settings)
Communication Switch 19 - Not used (do not change the settings)
Communication Switch 1A - Not used (do not change the settings)
Communication Switch 1B - Not used (do not change the settings)
Communication Switch 1C - Not used (do not change the settings)
Communication Switch 1D - Not used (do not change the settings)

Communication Switch 1E		
No	FUNCTION	COMMENTS
0	Extension access code (0 to 7) to turn V.8 protocol On/Off 0: On 1: Off	If the PABX does not support V.8/V.34 protocol procedure, set one of these bits to "1" to disable V.8. Example: If "0" is the PSTN access code, set bit 0 to 1. When the machine detects "0" as the first dialed number, it automatically disables V.8 protocol. (Alternatively, if "3" is the PSTN access code, set bit 3 to 1.)
1		
2		
3		
4		
5		
6		
7		

Communication Switch 1F		
No	FUNCTION	COMMENTS
0	Extension access code (8 and 9) to turn V.8 protocol On/Off 0: On 1: Off	Refer to communication switch 1E. Example: If "8" is the PSTN access code, set bit 0 to 1. When the machine detects "8" as the first dialed number, it automatically disables V.8 protocol.
1		
2-7	Not used	Do not change the settings.

5.3.5 G3 SWITCHES

G3 Switch 00		
No	FUNCTION	COMMENTS
0 1	Monitor speaker during communication (tx and rx) Bit 1 Bit 0 Setting 0 0 Disabled 0 1 Up to Phase B 1 0 All the time 1 1 Not used	(0, 0): The monitor speaker is disabled all through the communication. (0, 1): The monitor speaker is on up to phase B in the T.30 protocol. (1, 0): Used for testing. The monitor speaker is on all through the communication. Make sure that you reset these bits after testing.
2	Monitor speaker during memory transmission 0: Disabled 1: Enabled	1: The monitor speaker is enabled during memory transmission.
3-7	Not used	Do not change the settings.

G3 Switch 01		
No	FUNCTION	COMMENTS
0-3	Not used	Do not change the settings.
4	DIS frame length 0: 10 bytes 1: 4 bytes	1: The bytes in the DIS frame after the 4th byte will not be transmitted (set to 1 if there are communication problems with PC-based faxes which cannot receive the extended DIS frames).
5	Not used	Do not change the setting.
6	CED/ANSam transmission 0: Disabled 1: Enabled	Do not change this setting, unless the communication problem is caused by the CED/ANSam transmission.
7	Not used	Do not change the setting.

G3 Switch 02		
No	FUNCTION	COMMENTS
0	G3 protocol mode used 0: Standard and non-standard 1: Standard only	Change this bit to 1 only when the other end can only communicate with machines that send T.30-standard frames only. 1: Disables NSF/NSS signals (these are used in non-standard mode communication)
1-4	Not used	Do not change the settings.
5	Use of modem rate history for transmission using Quick/Speed Dials 0: Disabled 1: Enabled	0: Communications using Quick/Speed Dials always start from the highest modem rate. 1: The machine refers to the modem rate history for communications with the same machine when determining the most suitable rate for the current communication.
6	AI short protocol (transmission and reception) 0: Disabled 1: Enabled	Refer to the Core Technology Manual for details about AI Short Protocol.
7	Short preamble 0: Disabled 1: Enabled	Refer to the Core Technology Manual for details about Short Preamble.

BIT SWITCHES

G3 Switch 03		
No	FUNCTION	COMMENTS
0	DIS detection number (Echo countermeasure) 0: 1 1: 2	0: The machine will hang up if it receives the same DIS frame twice. 1: Before sending DCS, the machine will wait for the second DIS which is caused by echo on the line.
1	V.8 protocol in manual reception 0: Disabled 1: Enabled	0: The machine sends CED instead of ANSam when starting a manual reception. 1: The machine sends ANSam during manual reception.
2	V.8 protocol 0: Disabled 1: Enabled	0: V.8/V.34 communications will not be possible. Note: Do not set to 0 unless the line condition is always bad enough to slow down the data rate to 14.4 kbps or lower.
3	ECM frame size 0: 256 bytes 1: 64 bytes	Keep this bit at "0" in most cases.
4	CTC transmission conditions 0: After one PPR signal received 1: After four PPR signals received (ITU-T standard)	<p>0: When using ECM in non-standard (NSF/NSS) mode, the machine sends a CTC to drop back the modem rate after receiving a PPR, if the following condition is met in communications at 14.4, 12.0, 9.6, and 7.2 kbps.</p> <div style="border: 1px solid black; width: 100px; height: 100px; margin: 10px auto;"></div> <p>NTransmit- Number of transmitted frames NResend- Number of frames to be retransmitted</p> <p>1: When using ECM, the machine sends a CTC to drop back the modem rate after receiving four PPRs.</p> <p>PPR, CTC: These are ECM protocol signals.</p> <p>This bit is not effective in V.34 communications.</p>
5	Modem rate used for the next page after receiving a negative code (RTN or PIN) 0: No change 1: Fallback	1: The machine's tx modem rate will fall back before sending the next page if a negative code is received. This bit is ignored if ECM is being used.
6	V.8 protocol in manual transmission 0: Disabled 1: Enabled	1: The machine detects either ANSam or CED during manual transmission.
7	Not used	Do not change the setting.

G3 Switch 04		
No	FUNCTION	COMMENTS
0 to 3	Training error detection threshold	0 - F (Hex); 0 - 15 bits If the number of error bits in the received TCF is below this threshold, the machine informs the sender that training has succeeded.
4-7	Not used	Do not change the settings.

G3 Switch 05		
No	FUNCTION	COMMENTS
0 to 3	Initial Tx modem rate Bit 3 2 1 0 Setting (bps) 0 0 0 1 2.4 k 0 0 1 0 4.8 k 0 0 1 1 7.2 k 0 1 0 0 9.6 k 0 1 0 1 12.0 k 0 1 1 0 14.4 k 0 1 1 1 16.8 k 1 0 0 0 19.2 k 1 0 0 1 21.6 k 1 0 1 0 24.0 k 1 0 1 1 26.4 k 1 1 0 0 28.8 k 1 1 0 1 31.2 k 1 1 1 0 33.6 k Other settings - Not used	These bits set the initial starting modem rate for transmission. Use the dedicated transmission parameters if you need to change this for specific receivers. If a modem rate of 14.4 kbps or slower is selected, V.8 protocol should be disabled manually. Cross reference V.8 protocol on/off - G3 switch 03, bit 2
4 to 5	Initial modem type for 9.6 k or 7.2 kbps. Bit 5 Bit 4 Setting 0 0 V.29 0 1 V.17 1 0 V.34 1 1 Not used	These bits set the initial modem type for 9.6 and 7.2 kbps, if the initial modem rate is set at these speeds.
6-7	Not used	Do not change the settings.

BIT SWITCHES

G3 Switch 06		
No	FUNCTION	COMMENTS
0 to 3	<p>Initial Rx modem rate</p> <p>Bit 3 2 1 0 Setting (bps)</p> <p>0 0 0 1 2.4 k</p> <p>0 0 1 0 4.8 k</p> <p>0 0 1 1 7.2 k</p> <p>0 1 0 0 9.6 k</p> <p>0 1 0 1 12.0 k</p> <p>0 1 1 0 14.4 k</p> <p>0 1 1 1 16.8 k</p> <p>1 0 0 0 19.2 k</p> <p>1 0 0 1 21.6 k</p> <p>1 0 1 0 24.0 k</p> <p>1 0 1 1 26.4 k</p> <p>1 1 0 0 28.8 k</p> <p>1 1 0 1 31.2 k</p> <p>1 1 1 0 33.6 k</p> <p>Other settings - Not used</p>	<p>These bits set the initial starting modem rate for reception.</p> <p>Use a lower setting if high speeds pose problems during reception.</p> <p>If a modem rate of 14.4 kbps or slower is selected, V.8 protocol should be disabled manually.</p> <p>Cross reference V.8 protocol on/off - G3 switch 03, bit 2</p>
4 to 7	<p>Modem types available for reception</p> <p>Bit 7 6 5 4 Setting</p> <p>0 0 0 1 V.27ter</p> <p>0 0 1 0 V.27ter, V.29</p> <p>0 0 1 1 V.27ter, V.29 V.33</p> <p>0 1 0 0 V.27ter, V.29, V.17/V.33</p> <p>0 1 0 1 V.27ter, V.29, V.17/V33, V.34</p> <p>Other settings - Not used</p>	<p>The setting of these bits is used to inform the transmitting terminal of the available modem type for the machine in receive mode.</p> <p>If V.34 is not selected, V.8 protocol must be disabled manually.</p> <p>Cross reference V.8 protocol on/off - G3 switch 03, bit 2</p>

G3 Switch 07				
No	FUNCTION			COMMENTS
0 to 1	PSTN cable equalizer (tx mode: Internal)			Use a higher setting if there is signal loss at higher frequencies because of the length of wire between the modem and the telephone exchange. Use the dedicated transmission parameters for specific receivers. Also, try using the cable equalizer if one or more of the following symptoms occurs. <ul style="list-style-type: none"> • Communication error • Modem rate fallback occurs frequently. Note: This setting is not effective in V.34 communications.
1	Bit 1	Bit 0	Setting	
	0	0	None	
	0	1	Low	
	1	1	High	
2 to 3	PSTN cable equalizer (rx mode: Internal)			Use a higher setting if there is signal loss at higher frequencies because of the length of wire between the modem and the telephone exchange. Also, try using the cable equalizer if one or more of the following symptoms occurs. <ul style="list-style-type: none"> • Communication error with error codes such as 0-20, 0-23, etc. • Modem rate fallback occurs frequently. Note: This setting is not effective in V.34 communications.
3	Bit 3	Bit 2	Setting	
	0	0	None	
	0	1	Low	
	1	1	High	
4	PSTN cable equalizer (V.8/V.17 rx mode: External)			Keep this bit at "1".
	0: Disabled 1: Enabled			
5	PSTN cable equalizer (V.34 rx mode; External)			This function should only be turned on in environments where reception signal levels tend to be low.
6-7	Not used			Do not change the settings.

BIT SWITCHES

G3 Switch 08				
	FUNCTION		COMMENTS	
0	PABX cable equalizer (tx mode)		Use a higher setting if there is signal loss at higher frequencies because of the length of wire between the modem and the telephone exchange. Use the dedicated transmission parameters if you need to change this for specific receivers. Also, try using the cable equalizer if one or more of the following symptoms occurs: <ul style="list-style-type: none"> • Communication error • Modem rate fallback occurs frequently. Note: This setting is ineffective in V.34 communications.	
1	Bit 1	Bit 0		Setting
	0	0		None
	0	1		Low
	1	0		Medium
	1	1	High	
2	PABX cable equalizer (rx mode)		Use a higher setting if there is signal loss at higher frequencies because of the length of wire between the modem and the telephone exchange. Also, try using the cable equalizer if one or more of the following symptoms occurs: <ul style="list-style-type: none"> • Communication error with error codes such as 0-20, 0-23, etc. • Modem rate fallback occurs frequently. Note: This setting is ineffective in V.34 communications.	
3	Bit 3	Bit 2		Setting
	0	0		None
	0	1		Low
	1	0		Medium
	1	1	High	
4	PABX external cable equalizer (V.17, V.8 rx mode) 0: Disabled 1: Enabled		Set this bit to 0 when line quality is good. (e.g. for a digital PABX)	
5	PABX external cable equalizer (V.34 rx mode) 0: Disabled 1: Enabled		Set this bit to 0 when line quality is good. (e.g. for a digital PABX) The V.34 modem rate may decrease if the equalizer is over-corrected.	
6-7	Not used		Do not change these settings.	

G3 Switch 09 - Not used (do not change the settings)

G3 Switch 0A				
No	FUNCTION			COMMENTS
0 1	Maximum allowable carrier drop during image data reception			These bits set the acceptable modem carrier drop time. Try using a longer setting if error code 0-22 is frequent.
	Bit 1	Bit 0	Value (ms)	
	0	0	200	
	0	1	400	
	1	0	800	
	1	1	Not used	
2	Reception carrier drop operation. 0: Continue reception 1: Disconnect the line			This bit decides what the machine does when there is a carrier drop in the image data.
3	Not used			Do not change the setting.
4	Maximum allowable frame interval during image data reception. 0: 5 s 1: 13 s			This bit set the maximum interval between EOL (end-of-line) signals and the maximum interval between ECM frames from the other end. Try using a longer setting if error code 0-21 is frequent.
5	Not used			Do not change the setting.
6	Reconstruction time for the first line in receive mode 0: 6 s 1: 12 s			When the sending terminal is controlled by a computer, there may be a delay in receiving page data after the local machine accepts set-up data and sends CFR. This is outside the T.30 recommendation. But, if this delay occurs, set this bit to 1 to give the sending machine more time to send data. Refer to error code 0-20. ITU-T T.30 recommendation: The first line should come within 5 s of CFR.
7	Not used			Do not change the setting.

Fax Unit B404

G3 Switch 0B - Not used (do not change the settings)

G3 Switch 0C				
No	FUNCTION			COMMENTS
0 1	Pulse dialing method			P = Number of pulses sent out, N = Number dialed.
	Bit 1	Bit 0	Setting	
	0	0	Normal (P=N)	
	0	1	Oslo (P=10 - N)	
	1	0	Sweden (N+1)	
	1	1	Not used	
2-7	Not used			Do not change the settings.

BIT SWITCHES

G3 Switch 0D		
No	FUNCTION	COMMENTS
0-1	Not used	Do not change the settings.
2 to 5	Data rate threshold during V.34 reception Bit 5 4 3 2 Setting 0 0 0 0 Normal : 0 1 1 1 Lower by one step : 1 1 1 1 Lower by two steps	The machine changes the modulation parameters in the MPh signal to lower the initial modem rate during V.34 reception. If this switch is set to "0111", the machine lowers the initial speed one step, for example, from 28,800 to 26,400 bps. This switch reduces transmission time if the machine frequently sends PPR signals during V.34 reception.
6	Not used	Do not change the setting.
7	B signal detection time for V.34 polling transmission 0: 75 ms (default setting) 1: 65 ms	Change this switch only when there are communication errors during V.34 polling transmission to a machine with a Panasonic modem.

G3 Switch 0E		
No	FUNCTION	COMMENTS
0 to 7	CNG transmission OFF interval To input a value more than 3 s, use bits 3 to 0, and keep bits 4 to 7 at 0 3000 + 50 x N ms To input a value less than 3 s, use bits 4 to 7, and keep bits 0 to 3 at 1 3000 – 50 x N ms	Examples. 3100 ms: 50 x 2 = 100 Bits 4 to 7 must be 0 Bits 0 to 3 must be 2(H) So, enter 02H 2800 ms: 50 x 4 = 200 Bits 0 to 3 must be F(H) Bits 4 to 7 must be 4(H) So, enter 4FH

G3 Switch 0F		
No	FUNCTION	COMMENTS
0	Alarm when an error occurred in Phase C or later 0 : Disabled 1 : Enabled	If the customer wants to hear an alarm after each communication that had an error, change this bit to "1".
1	Alarm when the handset is off-hook at the end of communication 0 : Disabled 1 : Enabled	If the customer wants to hear an alarm if the handset is off-hook at the end of fax communication, change this bit to "1".
2-7	Not used	Do not change the settings.

5.4 NCU PARAMETERS

The following tables give the RAM addresses and the parameter calculation units that the machine uses for ringing signal detection and automatic dialing. The factory settings for each country are also given. Most of these must be changed by RAM read/write (Function 06-0), but some can be changed using NCU Parameter programming (Function 08-0); if Function 08-0 can be used, this will be indicated in the Remarks column. The RAM is programmed in hex code unless (BCD) is included in the Unit column.

Address	Function	Unit	Remarks																																																																																																
680400	Country code for NCU parameters	Use the Hex value to program the country code directly into this address, or use the decimal value to program it using Function 08-0 (parameter C.C.).																																																																																																	
		<table border="1"> <thead> <tr> <th>Country</th> <th>Decimal</th> <th>Hex</th> </tr> </thead> <tbody> <tr><td>France</td><td>00</td><td>00</td></tr> <tr><td>Germany</td><td>01</td><td>01</td></tr> <tr><td>UK</td><td>02</td><td>02</td></tr> <tr><td>Italy</td><td>03</td><td>03</td></tr> <tr><td>Austria</td><td>04</td><td>04</td></tr> <tr><td>Belgium</td><td>05</td><td>05</td></tr> <tr><td>Denmark</td><td>06</td><td>06</td></tr> <tr><td>Finland</td><td>07</td><td>07</td></tr> <tr><td>Ireland</td><td>08</td><td>08</td></tr> <tr><td>Norway</td><td>09</td><td>09</td></tr> <tr><td>Sweden</td><td>10</td><td>0A</td></tr> <tr><td>Switzerland</td><td>11</td><td>0B</td></tr> <tr><td>Portugal</td><td>12</td><td>0C</td></tr> <tr><td>Holland</td><td>13</td><td>0D</td></tr> <tr><td>Spain</td><td>14</td><td>0E</td></tr> <tr><td>Israel</td><td>15</td><td>0F</td></tr> <tr><td>USA</td><td>17</td><td>11</td></tr> <tr><td>Asia</td><td>18</td><td>12</td></tr> <tr><td>Hong Kong</td><td>20</td><td>14</td></tr> <tr><td>South Africa</td><td>21</td><td>15</td></tr> <tr><td>Australia</td><td>22</td><td>16</td></tr> <tr><td>New Zealand</td><td>23</td><td>17</td></tr> <tr><td>Singapore</td><td>24</td><td>18</td></tr> <tr><td>Malaysia</td><td>25</td><td>19</td></tr> <tr><td>China</td><td>26</td><td>1A</td></tr> <tr><td>Taiwan</td><td>27</td><td>1B</td></tr> <tr><td>Korea</td><td>28</td><td>1C</td></tr> <tr><td>Greece</td><td>33</td><td>21</td></tr> <tr><td>Hungary</td><td>34</td><td>22</td></tr> <tr><td>Czech</td><td>35</td><td>23</td></tr> <tr><td>Poland</td><td>36</td><td>24</td></tr> </tbody> </table>	Country	Decimal	Hex	France	00	00	Germany	01	01	UK	02	02	Italy	03	03	Austria	04	04	Belgium	05	05	Denmark	06	06	Finland	07	07	Ireland	08	08	Norway	09	09	Sweden	10	0A	Switzerland	11	0B	Portugal	12	0C	Holland	13	0D	Spain	14	0E	Israel	15	0F	USA	17	11	Asia	18	12	Hong Kong	20	14	South Africa	21	15	Australia	22	16	New Zealand	23	17	Singapore	24	18	Malaysia	25	19	China	26	1A	Taiwan	27	1B	Korea	28	1C	Greece	33	21	Hungary	34	22	Czech	35	23	Poland	36	24	
Country	Decimal	Hex																																																																																																	
France	00	00																																																																																																	
Germany	01	01																																																																																																	
UK	02	02																																																																																																	
Italy	03	03																																																																																																	
Austria	04	04																																																																																																	
Belgium	05	05																																																																																																	
Denmark	06	06																																																																																																	
Finland	07	07																																																																																																	
Ireland	08	08																																																																																																	
Norway	09	09																																																																																																	
Sweden	10	0A																																																																																																	
Switzerland	11	0B																																																																																																	
Portugal	12	0C																																																																																																	
Holland	13	0D																																																																																																	
Spain	14	0E																																																																																																	
Israel	15	0F																																																																																																	
USA	17	11																																																																																																	
Asia	18	12																																																																																																	
Hong Kong	20	14																																																																																																	
South Africa	21	15																																																																																																	
Australia	22	16																																																																																																	
New Zealand	23	17																																																																																																	
Singapore	24	18																																																																																																	
Malaysia	25	19																																																																																																	
China	26	1A																																																																																																	
Taiwan	27	1B																																																																																																	
Korea	28	1C																																																																																																	
Greece	33	21																																																																																																	
Hungary	34	22																																																																																																	
Czech	35	23																																																																																																	
Poland	36	24																																																																																																	
680401	Line current detection time	20 ms	Line current detection is disabled. Line current is not detected if 680401 contains FF.																																																																																																
680402	Line current wait time																																																																																																		
680403	Line current drop detect time																																																																																																		

NCU PARAMETERS

Address	Function	Unit	Remarks
680404	PSTN dial tone frequency upper limit (high byte)	Hz (BCD)	If both addresses contain FF(H), tone detection is disabled. See Note 9
680405	PSTN dial tone frequency upper limit (low byte)		
680406	PSTN dial tone frequency lower limit (high byte)	Hz (BCD)	If both addresses contain FF(H), tone detection is disabled. See Note 9
680407	PSTN dial tone frequency lower limit (low byte)		
680408	PSTN dial tone detection time	20 ms	If 680408 contains FF(H), the machine pauses for the pause time (address 68040D / 68040E). Italy: See Note 2, 9 See Note 9
680409	PSTN dial tone reset time (LOW)		
68040A	PSTN dial tone reset time (HIGH)		
68040B	PSTN dial tone continuous tone time		
68040C	PSTN dial tone permissible drop time		
68040D	PSTN wait interval (LOW)		
68040E	PSTN wait interval (HIGH)		
68040F	PSTN ring-back tone detection time	20 ms	Detection is disabled if this contains FF.
680410	PSTN ring-back tone off detection time	20 ms	
680411	PSTN detection time for silent period after ring-back tone detected (LOW)	20 ms	
680412	PSTN detection time for silent period after ring-back tone detected (HIGH)	20 ms	
680413	PSTN busy tone frequency upper limit (high byte)	Hz (BCD)	If both addresses contain FF(H), tone detection is disabled.
680414	PSTN busy tone frequency upper limit (low byte)		
680415	PSTN busy tone frequency lower limit (high byte)	Hz (BCD)	If both addresses contain FF(H), tone detection is disabled.
680416	PSTN busy tone frequency lower limit (low byte)		
680417	PABX dial tone frequency upper limit (high byte)	Hz (BCD)	If both addresses contain FF(H), tone detection is disabled.
680418	PABX dial tone frequency upper limit (low byte)		
680419	PABX dial tone frequency lower limit (high byte)	Hz (BCD)	If both addresses contain FF(H), tone detection is disabled.
68041A	PABX dial tone frequency lower limit (low byte)		

NCU PARAMETERS

Address	Function	Unit	Remarks																						
68041B	PABX dial tone detection time	20 ms	If 68041B contains FF, the machine pauses for the pause time (680420 / 680421).																						
68041C	PABX dial tone reset time (LOW)																								
68041D	PABX dial tone reset time (HIGH)																								
68041E	PABX dial tone continuous tone time																								
68041F	PABX dial tone permissible drop time																								
680420	PABX wait interval (LOW)																								
680421	PABX wait interval (HIGH)																								
680422	PABX ringback tone detection time	20 ms	If both addresses contain																						
680423	PABX ringback tone off detection time	20 ms	FF(H), tone detection is disabled.																						
680424	PABX detection time for silent period after ringback tone detected (LOW)	20 ms	If both addresses contain FF(H), tone detection is disabled.																						
680425	PABX detection time for silent period after ringback tone detected (HIGH)	20 ms																							
680426	PABX busy tone frequency upper limit (high byte)	Hz (BCD)	If both addresses contain FF(H), tone detection is disabled.																						
680427	PABX busy tone frequency upper limit (low byte)																								
680428	PABX busy tone frequency lower limit (high byte)	Hz (BCD)	If both addresses contain FF(H), tone detection is disabled.																						
680429	PABX busy tone frequency lower limit (low byte)																								
68042A	Busy tone ON time: range 1	20 ms																							
68042B	Busy tone OFF time: range 1																								
68042C	Busy tone ON time: range 2																								
68042D	Busy tone OFF time: range 2																								
68042E	Busy tone ON time: range 3																								
68042F	Busy tone OFF time: range 3																								
680430	Busy tone ON time: range 4																								
680431	Busy tone OFF time: range 4																								
680432	Busy tone continuous tone detection time																								
680433	<p>Busy tone signal state time tolerance for all ranges, and number of cycles required for detection (a setting of 4 cycles means that ON-OFF-ON or OFF-ON-OFF must be detected twice).</p> <p>Tolerance (±)</p> <table border="0"> <tr> <td>Bit</td> <td>1</td> <td>0</td> <td></td> <td></td> </tr> <tr> <td></td> <td>0</td> <td>0</td> <td>75%</td> <td rowspan="4">Bits 2 and 3 must always be kept at 0.</td> </tr> <tr> <td></td> <td>0</td> <td>1</td> <td>50%</td> </tr> <tr> <td></td> <td>1</td> <td>0</td> <td>25%</td> </tr> <tr> <td></td> <td>1</td> <td>1</td> <td>12.5%</td> </tr> </table> <p>Bits 7, 6, 5, 4 - number of cycles required for cadence detection</p>			Bit	1	0				0	0	75%	Bits 2 and 3 must always be kept at 0.		0	1	50%		1	0	25%		1	1	12.5%
Bit	1	0																							
	0	0	75%	Bits 2 and 3 must always be kept at 0.																					
	0	1	50%																						
	1	0	25%																						
	1	1	12.5%																						

Fax Unit B404

NCU PARAMETERS

Address	Function	Unit	Remarks
680434	International dial tone frequency upper limit (high byte)	Hz (BCD)	If both addresses contain FF(H), tone detection is disabled.
680435	International dial tone frequency upper limit (low byte)		
680436	International dial tone frequency lower limit (high byte)	Hz (BCD)	If both addresses contain FF(H), tone detection is disabled.
680437	International dial tone frequency lower limit (low byte)		
680438	International dial tone detection time	20 ms	If 680438 contains FF, the machine pauses for the pause time (68043D / 68043E). Belgium: See Note 2.
680439	International dial tone reset time (LOW)		
68043A	International dial tone reset time (HIGH)		
68043B	International dial tone continuous tone time		
68043C	International dial tone permissible drop time		
68043D	International dial wait interval (LOW)		
68043E	International dial wait interval (HIGH)	Hz (BCD)	If both addresses contain FF(H), tone detection is disabled.
68043F	Country dial tone upper frequency limit (HIGH)		
680440	Country dial tone upper frequency limit (LOW)		
680441	Country dial tone lower frequency limit (HIGH)		If both addresses contain FF(H), tone detection is disabled.
680442	Country dial tone lower frequency limit (LOW)		

NCU PARAMETERS

Address	Function	Unit	Remarks
680443	Country dial tone detection time	20 ms	If 680443 contains FF, the machine pauses for the pause time (680448 / 680449).
680444	Country dial tone reset time (LOW)		
680445	Country dial tone reset time (HIGH)		
680446	Country dial tone continuous tone time		
680447	Country dial tone permissible drop time		
680448	Country dial wait interval (LOW)		
680449	Country dial wait interval (HIGH)		
68044A	Time between opening or closing the DO relay and opening the OHDI relay	1 ms	See Notes 3, 6, 8 and 9. Function 08-0 (parameter 11).
68044B	Break time for pulse dialing	1 ms	See Note 3 and 9. Function 08-0 (parameter 12).
68044C	Make time for pulse dialing	1 ms	See Note 3 and 9. Function 08-0 (parameter 13).
68044D	Time between final OHDI relay closure and DO relay opening or closing	1 ms	See Notes 6, 8 and 9. Function 08-0 (parameter 14). This parameter is only valid in Europe.
68044E	Minimum pause between dialed digits (pulse dial mode)	20 ms	See Note 3 and 8. Function 08-0 (parameter 15). See Note 9
68044F	Time waited when a pause is entered at the operation panel		Function 08-0 (parameter 16). See Note 9
680450	DTMF tone on time	1 ms	Function 08-0 (parameter 17). See Note 9
680451	DTMF tone off time		Function 08-0 (parameter 18). See Note 9
680452	Tone attenuation level of DTMF signals while dialing	-dBm x 0.5	Function 08-0 (parameter 19). See Note 5 and 9.
680453	Tone attenuation value difference between high frequency tone and low frequency tone in DTMF signals	-dBm x 0.5	Function 08-0 (parameter 20). The setting must be less than -5dBm, and should not exceed the setting at 680452h above. See Note 5 and 9.
680454	PSTN: DTMF tone attenuation level after dialling	-dBm x 0.5	Function 08-0 (parameter 21). See Note 5.
680455	ISDN: DTMF tone attenuation level after dialling	-dBm x 0.5	See Note 5
680456	Not used		Do not change the settings.

NCU PARAMETERS

Address	Function	Unit	Remarks
680457	Time between 68044Dh (NCU parameter 14) and 68044Eh (NCU parameter 15)	1 ms	This parameter takes effect when the country code is set to France.
680458	Not used		Do not change the setting.
680459	Grounding time (ground start mode)	20 ms	The Gs relay is closed for this interval.
68045A	Break time (flash start mode)	1 ms	The OHD1 relay is open for this interval.
68045B	International dial access code (High)	BCD	For a code of 100: 68045B - F1 68045C - 00
68045C	International dial access code (Low)		
68045D	PSTN access pause time	20 ms	This time is waited for each pause input after the PSTN access code. If this address contains FF[H], the pause time stored in address 68044F is used. Do not set a number more than 7 in the UK.
68045E	Progress tone detection level, and cadence detection enable flags	Bit 7 Bit 6 Bit 5 dBm 0 0 0 -25.0 0 0 1 -35.0 0 1 0 -30.0 1 0 0 -40.0 1 1 0 -49.0 Bits 2, 0 - See Note 2.	
68045F to 680464	Not used		Do not change the settings.
680465	Long distance call prefix (HIGH)	BCD	For a code of 0: 680465 - FF 680466 - F0
680466	Long distance call prefix (LOW)	BCD	
680467 to 680471	Not used		Do not change the settings.

NCU PARAMETERS

Address	Function	Unit	Remarks
680472	Acceptable ringing signal frequency: range 1, upper limit	1000/ N (Hz).	Function 08-0 (parameter 02). See Note 9.
680473	Acceptable ringing signal frequency: range 1, lower limit		Function 08-0 (parameter 03). See Note 9.
680474	Acceptable ringing signal frequency: range 2, upper limit		Function 08-0 (parameter 04). See Note 9.
680475	Acceptable ringing signal frequency: range 2, lower limit		Function 08-0 (parameter 05). See Note 9.
680476	Number or rings until a call is detected	1	Function 08-0 (parameter 06). The setting must not be zero. See Note 9.
680477	Minimum required length of the first ring	20 ms	See Note 4. Function 08-0 (parameter 07). See Note 9.
680478	Minimum required length of the second and subsequent rings	20 ms	Function 08-0 (parameter 08). See Note 9.
680479	Ringing signal detection reset time (LOW)	20 ms	Function 08-0 (parameter 09). See Note 9.
68047A	Ringing signal detection reset time (HIGH)		Function 08-0 (parameter 10). See Note 9.
68047B to 680480	Not used		Do not change the settings.
680481	Interval between dialing the last digit and switching the Oh relay over to the external telephone when dialing from the operation panel in handset mode.	20 ms	Factory setting: 500 ms
680482	Bits 0 and 1 - Handset off-hook detection time Bit1 0 Setting 0 0 200 ms 0 1 800 ms Other Not used Bits 2 and 3 - Handset on-hook detection time Bit3 2 Setting 0 0 200 ms 0 1 800 ms Other Not used Bits 4 to 7 - Not used		

Fax Unit B404

NCU PARAMETERS

Address	Function	Unit	Remarks
680483 to 6804A0	Not used		Do not change the settings.
6804A1	Acceptable CED detection frequency upper limit (high byte)	BCD (Hz)	If both addresses contain FF(H), tone detection is disabled.
6804A2	Acceptable CED detection frequency upper limit (low byte)		
6804A3	Acceptable CED detection frequency lower limit (high byte)	BCD (Hz)	If both addresses contain FF(H), tone detection is disabled.
6804A4	Acceptable CED detection frequency lower limit (low byte)		
6804A5	CED detection time	20 ms ± 20 ms	Factory setting: 200 ms
6804A6	Acceptable CNG detection frequency upper limit (high byte)	BCD (Hz)	If both addresses contain FF(H), tone detection is disabled.
6804A7	Acceptable CNG detection frequency upper limit (low byte)		
6804A8	Acceptable CNG detection frequency lower limit (high byte)	BCD (Hz)	If both addresses contain FF(H), tone detection is disabled.
6804A9	Acceptable CNG detection frequency lower limit (low byte)		
6804AA	Not used		Do not change the setting.
6804AB	CNG on time	20 ms	Factory setting: 500 ms
6804AC	CNG off time	20 ms	Factory setting: 200 ms
6804AD	Number of CNG cycles required for detection		The data is coded in the same way as address 680433.
6804AE	Not used		Do not change the settings.
6804AF	Acceptable AI short protocol tone (800Hz) detection frequency upper limit (high byte)	Hz (BCD)	If both addresses contain FF(H), tone detection is disabled.
6804B0	Acceptable AI short protocol tone (800Hz) detection frequency upper limit (low byte)		
6804B1	Acceptable AI short protocol tone (800Hz) detection frequency lower limit (high byte)	Hz(BCD)	If both addresses contain FF(H), tone detection is disabled.
6804B2	Acceptable AI short protocol tone (800Hz) detection frequency lower limit (low byte)		
6804B3	Detection time for 800 Hz AI short protocol tone	20 ms	Factory setting: 360 ms
6804B4	PSTN: Tx level from the modem	- dBm	Function 08-0 (parameter 01). See Note 9.
6804B5	PSTN: 1100 Hz tone transmission level	- N 6804B4 - 0.5N 6804B5 (dB) See Note 7.	
6804B6	PSTN: 2100 Hz tone transmission level	- N6804B4 - 0.5N 6804B6 (dB) See Note 7.	

NCU PARAMETERS

Address	Function	Unit	Remarks
6804B7	PABX: Tx level from the modem	- dBm	
6804B8	PABX: 1100 Hz tone transmission level	- N 6804B7 - 0.5N 6804B8 (dB)	
6804B9	PABX: 2100 Hz tone transmission level	- N 6804B7 - 0.5N 6804B9 (dB)	
6804BA	ISDN: Tx level from the modem	- dBm	The setting must be between -12dBm and -15dBm.
6804BB	ISDN: 1100 Hz tone transmission level	- N 6804BA - 0.5N 6804BB (dB)	
6804BC	ISDN: 2100 Hz tone transmission level	- N 6804BA - 0.5N 6804BC (dB)	
6804BD	Modem turn-on level (incoming signal detection level)	-37-0.5N (dBm)	
6804BE to 6804C6	Not used		Do not change the settings.
6804C7	Bits 0 to 3 – Not used. Bit 4 – V.34 protocol dump 0 : Simple, 1 : Detailed (default) Bits 5 to 7 – Not used.		
6804C8 to 6804D9	Not used		Do not change the settings.
6804DA	T.30 T1 timer	1 s	See Note 9.
6804E0 bit 3	Maximum wait time for post message	0 : 12 s 1 : 30 s	1 : Maximum wait time for post message (EOP/EOM/MPS) can be changed to 30 s. Change this bit to “1” if communication errors occur frequently during V.17 reception.

Fax Unit B404

NCU PARAMETERS

NOTES

1. If a setting is not required, store FF in the address.
2. Italy and Belgium only

RAM address 68045E: the lower four bits have the following meaning.

Bit 2 - 1: International dial tone cadence detection enabled (Belgium)

Bit 1 - Not used

Bit 0 - 1: PSTN dial tone cadence detection enabled (Italy)

If bit 0 or bit 2 is set to 1, the functions of the following RAM addresses are changed.

680408 (if bit 0 = 1) or 680438 (if bit 2 = 1): tolerance for on or off state duration (%), and number of cycles required for detection, coded as in address 680433.

68040B (if bit 0 = 1) or 68043B (if bit 2 = 1): on time, hex code (unit = 20 ms)

68040C (if bit 0 = 1) or 68043C (if bit 2 = 1): off time, hex code (unit = 20 ms)

3. Pulse dial parameters (addresses 68044A to 68044F) are the values for 10 pps. If 20 pps is used, the machine automatically compensates.
4. The first ring may not be detected until 1 to 2.5 wavelengths after the time specified by this parameter.
5. The calculated level must be between 0 and 10.
The attenuation levels calculated from RAM data are:
High frequency tone: $- 0.5 \times N_{680452/680454}$ dBm
Low frequency tone: $- 0.5 \times (N_{680452/680454} + N_{680453})$ dBm
Note: N_{680452} , for example, means the value stored in address 680452(H)
6. 68044A: Europe - Between Ds opening and Di opening, France - Between Ds closing and Di opening
68044D: Europe - Between Ds closing and Di closing, France - Between Ds opening and Di closing
7. Tone signals which frequency is lower than 1500Hz (e.g., 800Hz tone for AI short protocol) refer to the setting at 6804B5h. Tones which frequency is higher than 1500Hz refer to the setting at 6804B6h.

8. The actual inter-digit pause (pulse dial mode) is the sum of the periods specified by RAM addresses 68044A, 68044D, and 68044E.

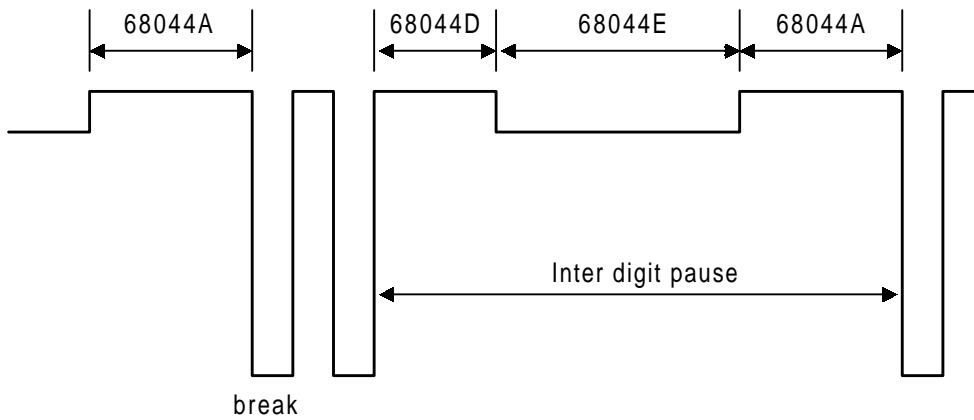

9. For European models, these parameters should not be changed in the field. The default values of these parameters have been approved by CTR21 and/or EG201121. Therefore, a change in any one of these values would constitute a violation of these requirements.

5.5 DEDICATED TRANSMISSION PARAMETERS

Each Quick Dial Key and Speed Dial Code has eight bytes of programmable parameters allocated to it. If transmissions to a particular machine often experience problems, store that terminal's fax number as a Quick Dial or Speed Dial, and adjust the parameters allocated to that number.

The programming procedure will be explained first. Then, the eight bytes will be described.

5.5.1 PROGRAMMING PROCEDURE

1. Make sure the machine is in standby mode. Press 'User Tools' key then choose '4. Fax Features'.
2. Select the "1. Program/Delete", then press "OK" key.
Select "1. Prog. Quick dial" or "3. Prog. Speed Dial" then press "OK" key
Example: Change the Parameters in Quick Dial 01.
3. Press Quick Dial key 01 and "OK" key.
NOTE: The selected Quick or Speed Dial must be programmed beforehand.
4. When the programmed dial number is displayed, press S - V - C using Quick Dial keys, then press 'Start'.
5. The settings for byte 0 are now displayed. Press a number from 0 to 7 corresponding to the bit that you wish to change.
Example: Change bit 7 to 1: Press 7
6. To scroll through the parameter bytes, either:
Select the next byte: press '→' Switch'
or
Select the previous byte: press '←' Switch' until the correct byte is displayed.
Then go back to step 6.
7. After the setting is changed, press "OK" until "Programmed" displays.
8. To finish, press 'User Tools'.

5.5.2 PARAMETERS

The initial settings of the following parameters are all FF(H) - all the parameters are disabled.

Switch 01	
FUNCTION AND COMMENTS	
ITU-T T1 time (for PSTN G3 mode) If the connection time to a particular terminal is longer than the NCU parameter setting, adjust this byte. The T1 time is the value stored in this byte (in hex code), multiplied by 1 second.	
Range: 0 to 120 s (00h to 78h) FFh - The local NCU parameter factory setting is used. Do not program a value between 79h and FEh.	

Switch 02		
No	FUNCTION	COMMENTS
0 to 4	Tx level Bit 4 3 2 1 0 Setting 0 0 0 0 0 0 0 0 0 0 1 -1 0 0 0 1 0 -2 0 0 0 1 1 -3 0 0 1 0 0 -4 : : 0 1 1 1 1 -15 1 1 1 1 1 Disabled	If communication with a particular remote terminal often contains errors, the signal level may be inappropriate. Adjust the Tx level for communications with that terminal until the results are better. If the setting is 'Disabled', the NCU parameter 01 setting is used. Note: Do not use settings other than listed on the left.
5 to 7	Cable equalizer Bit 7 6 5 Setting 0 0 0 None 0 0 1 Low 0 1 0 Medium 0 1 1 High 1 1 1 Disabled	Use a higher setting if there is signal loss at higher frequencies because of the length of wire between the modem and the telephone exchange when calling the number stored in this Quick/Speed Dial. Also, try using the cable equalizer if one or more of the following symptoms occurs. <ul style="list-style-type: none"> • Communication error with error codes such as 0-20, 0-23, etc. • Modem rate fallback occurs frequently. Note: Do not use settings other than listed on the left. If the setting is 'Disabled', the bit switch setting is used.

Fax Unit B404

DEDICATED TRANSMISSION PARAMETERS

Switch 03				
No	FUNCTION			COMMENTS
0 to 3	Initial Tx modem rate			<p>If training with a particular remote terminal always takes too long, the initial modem rate may be too high. Reduce the initial Tx modem rate using these bits.</p> <p>For the settings 14.4 or kbps slower, Switch 04 bit 4 must be changed to 0.</p> <p>Note: Do not use settings other than listed on the left.</p> <p>If the setting is 'Disabled', the bit switch setting is used.</p>
	Bit 3 2 1 0	Setting (bps)		
	0 0 0 0	Not used		
	0 0 0 1	2,400		
	0 0 1 0	4,800		
	0 0 1 1	7,200		
	0 1 0 0	9,600		
	0 1 0 1	12,000		
	0 1 1 0	14,400		
	0 1 1 1	16,800		
	1 0 0 0	19,200		
	1 0 0 1	21,600		
	1 0 1 0	24,000		
	1 0 1 1	26,400		
	1 1 0 0	28,800		
1 1 0 1	31,200			
1 1 1 0	33,600			
1 1 1 1	Disabled			
Other settings:			Not used	
4-5	Not used			Do not change the settings.
6	AI short protocol 0: Off 1: Disabled			Refer to Appendix B in the Group 3 Facsimile Manual for details about AI Short Protocol. If the setting is 'Disabled', the bit switch setting is used.
7	Not used			Do not change the setting.

Switch 04				
No	FUNCTION			COMMENTS
0 1	Inch-mm conversion before tx			<p>The machine uses inch-based resolutions for scanning. If "inch only" is selected, the printed copy may be slightly distorted at the other end if that machine uses mm-based resolutions.</p> <p>If the setting is 'Disabled', the bit switch setting is used.</p>
	Bit 1	Bit 0	Setting	
	0	0	Inch-mm conversion available	
	0	1	Inch only	
	1	0	Not used	
1	1	Disabled		
2 to 3	DIS/NSF detection method			<p>(0, 1): Use this setting if echoes on the line are interfering with the set-up protocol at the start of transmission. The machine will then wait for the second DIS or NSF before sending DCS or NSS.</p> <p>If the setting is 'Disabled', the bit switch setting is used.</p>
	Bit 3	Bit 2	Setting	
	0	0	First DIS or NSF	
	0	1	Second DIS or NSF	
	1	0	Not used	
1	1	Disabled		

DEDICATED TRANSMISSION PARAMETERS

Switch 04																		
No	FUNCTION		COMMENTS															
4	V.8 protocol 0: Off 1: Disabled		If transmissions to a specific destination always end at a lower modem rate (14,400 bps or lower), disable V.8 protocol so as not to use V.34 protocol. 0: V.34 communication will not be possible. If the setting is 'Disabled', the bit switch setting is used.															
5	Compression modes available in transmit mode 0: MH only 1: Disabled		This bit determines the capabilities that are informed to the other terminal during transmission. If the setting is 'Disabled', the bit switch setting is used.															
6 7	ECM during transmission	<table border="1"> <thead> <tr> <th>Bit 7</th> <th>Bit 6</th> <th>Setting</th> </tr> </thead> <tbody> <tr> <td>0</td> <td>0</td> <td>Off</td> </tr> <tr> <td>0</td> <td>1</td> <td>On</td> </tr> <tr> <td>1</td> <td>0</td> <td>Not used</td> </tr> <tr> <td>1</td> <td>1</td> <td>Disabled</td> </tr> </tbody> </table>	Bit 7	Bit 6	Setting	0	0	Off	0	1	On	1	0	Not used	1	1	Disabled	For example, if ECM is switched on but is not wanted when sending to a particular terminal, use the (0, 0) setting. Note that V.8/V.34 protocol and JBIG compression are automatically disabled if ECM is disabled. If the setting is 'Disabled', the bit switch setting is used.
Bit 7	Bit 6	Setting																
0	0	Off																
0	1	On																
1	0	Not used																
1	1	Disabled																

Switch 05 - Not used (do not change the settings)
Switch 06 - Not used (do not change the settings)
Switch 07 - Not used (do not change the settings)
Switch 08 - Not used (do not change the settings)
Switch 09 - Not used (do not change the settings)
Switch 0A - Not used (do not change the settings)

5.6 SERVICE RAM ADDRESSES

⚠ CAUTION

Do not change the settings which are marked as “Not used” or “Read only.”

680001 to 680004(H) - ROM version (Read only)

- 680001(H) - Revision number (BCD)
- 680002(H) - Year (BCD)
- 680003(H) - Month (BCD)
- 680004(H) - Day (BCD)

680006 to 680015(H) - Machine’s serial number (16 digits - ASCII)

680018(H) - Total program checksum (low)

680019(H) - Total program checksum (high)

680020 to 68003F(H) - System bit switches

680040 to 68004F(H) - Scanner bit switches

680050 to 68005F(H) - Printer bit switches

680060 to 68007F(H) - Communication bit switches

680080 to 68008F(H) - G3 bit switches

6800C0(H) - User parameter switch 00 (SWUER_00)

Bit 0: Stamp home position 0: Disabled, 1: Enabled

Bits 1 to 3: Scanning contrast home position

Bit	3	2	1	Setting
	0	0	0	Not used
	0	0	1	Position 1 (Lightest)
	0	1	0	Position 2
	0	1	1	Position 3 (Medium)
	1	0	0	Position 4
	1	0	1	Position 5 (Darkest)

Bits 4 and 5: Scanning resolution home position

(This switch is not printed on the user parameter list.)

Bit	5	4	Setting
	0	0	Standard
	0	1	Detail
	1	0	Fine
	1	1	Not used

Bit 6: Transmission mode home position

(This switch is not printed on the user parameter list.)

0: Memory tx, 1: Immediate tx

Bit 7: Not used

6800C1(H) - User parameter switch 01 (SWUSR_01)

Bit 0: Label insertion home position 0: Disabled, 1: Enabled

Bit 1: Not used

Bit 2: Automatic reduction (tx) home position 0: Disabled, 1: Enabled

Bits 3 and 4: Scanning mode LED home position

(This switch is not printed on the user parameter list.)

Bit	4	3	Setting
	0	0	Text
	0	1	Not used
	1	0	Photo
	1	1	Special Original (See the note below)

NOTE: The “Special Original” setting is not explained in the Operator’s Manual, because it can be selected only if System Switch 19 – bit 7 is set to “1”.

Bit 5: TTI print home position 0: Disabled, 1: Enabled

Bit 6: Not used

Bit 7: Settings return to home position after scanning 0: Disabled, 1: Enabled

6800C2(H) - User parameter switch 02 (SWUSR_02)

Bit 0: Forwarding mark printing on forwarded messages 0: Disabled, 1: Enabled

Bit 1: Center mark printing on received copies

(This switch is not printed on the user parameter list.)

0: Disabled, 1: Enabled

Bit 2: Reception time printing

(This switch is not printed on the user parameter list.)

0: Disabled, 1: Enabled

Bit 3: TSI print on received messages 0: Disabled, 1: Enabled

Bit 4: Checkered mark printing

(This switch is not printed on the user parameter list.)

0: Disabled, 1: Enabled

Bits 5 and 7: Not used

6800C3(H) - User parameter switch 03 (SWUSR_03: Automatic report printout)

Bit 0: Transmission result report (memory transmissions) 0: Off, 1: On

Bit 1: Not used

Bit 2: Memory storage report 0: Off, 1: On

Bit 3: Polling reserve report (polling reception) 0: Off, 1: On

Bit 4: Polling result report (polling reception) 0: Off, 1: On

Bit 5: Transmission result report (immediate transmissions) 0: Off, 1: On

Bit 6: Not used

Bit 7: Journal 0: Off, 1: On

SERVICE RAM ADDRESSES

6800C4(H) - User parameter switch 04 (SWUSR_04: Automatic report printout)

Bits 0 to 6: Not used

Bit 7: Inclusion of a sample image on reports 0: Off, 1: On

6800C5(H) - User parameter switch 05 (SWUSR_05)

Bit 0: Substitute reception when the base copier is in an SC condition

0: Enabled, 1: Disabled

Bits 1 and 2: Condition for substitute rx when the machine cannot print messages (Paper end, Toner end, and Jam during night mode)

Bit	2	1	Setting
-----	---	---	---------

0	0	0	The machine receives all the fax messages.
---	---	---	--

0	1	1	The machine receives the fax messages with RTI or CSI.
---	---	---	--

1	0	0	The machine receives the fax messages with the same ID code.
---	---	---	--

1	1	1	The machine does not receive anything.
---	---	---	--

Bit 3: Not used

Bit 4: Restricted Access using personal codes 0: Off, 1: On

Bit 5: Just size printing 0: Off, 1: On

Bit 6: Not used

Bit 7: Add paper display when a cassette is empty 0: Off, 1: On

6800C6(H) - User parameter switch 06 (SWUSR_06)

Bit 0: Not used

Bits 1 to 3: Not used

Bit 4: Quick dial label print format

0: Suitable for white paper, 1: Suitable for transparent paper

Bits 5 to 7: Not used

6800C7(H) - User parameter switch 07 (SWUSR_07)

Bits 0 and 1: Not used

Bit 2: Parallel memory transmission 0: Off, 1: On

Bits 3 to 7: Not used

6800C8(H) - User parameter switch 08 (SWUSR_08)

Bits 0 and 1: Not used.

Bit 2: Authorized reception

0: Only faxes from senders whose RTIs/CSIs are specified for this feature are accepted.

1: Only faxes from senders whose RTIs/CSIs are not specified for this feature are accepted.

Bits 3 to 7: Not used.

6800C9(H) - User parameter switch 09 (SWUSR_09)

Bits 0 to 7: Not used

6800CA(H) - User parameter switch 10 (SWUSR_0A)

Bits 0 to 2: Not used

Bit 3: Page reduction 0: Off, 1: On

Bits 4 to 7: Not used

6800CB(H) - User parameter switch 11 (SWUSR_0B)

Bit 0: Not used

Bits 1 to 5: Not used

Bit 6: Printout of messages received while acting as a forwarding station
0: Off, 1: On

Bit 7: Not used

6800CC(H) - User parameter switch 12 (SWUSR_0C)

Bits 0 to 7: Not used

6800CD(H) - User parameter switch 13 (SWUSR_0D)

(This switch is not printed on the user parameter list.)

Bits 0 and 1: PSTN access method from behind a PABX

Bit	1	0	Setting
	0	0	PSTN
	0	1	Loop start
	1	0	Ground start
	1	1	Flash start

Bits 2 to 7: Not used

6800CE(H) - User parameter switch 14 (SWUSR_0E)

Bit 0: Message printout while the machine is in Night Timer mode 0: On, 1: Off

Bit 1: Maximum document length detection (Well log)

0: Double letter, 1: 1200 mm (Memory transmission)

Bit 2: Batch transmission 0: Off, 1: On

Bit 3: Setting before mode key (Copy/Fax/Printer) is pressed

0: Not cleared, 1: Cleared

Bits 4 to 6: Not used

Bit 7: Manual service call (sends the system parameter list to the service station)

0: Off, 1: On

SERVICE RAM ADDRESSES

6800CF(H) - User parameter switch 15 (SWUSR_0F)

Bits 0, 1 and 2: Cassette for fax printout

Bit	2	1	0	Setting
	0	0	1	1st paper feed station
	0	1	0	2nd paper feed station
	0	1	1	3rd paper feed station
	1	0	0	4th paper feed station
	Other settings			Not used

Bits 3 and 4: Not used

Bit 5: Using the cassette specified by bits 0, 1 and 2 above only 0: On, 1: Off

Bits 6 and 7: Not used

6800D0(H) – User parameter switch 16 (SWUSR_10)

(This switch is not printed on the user parameter list.)

Bits 0 and 1: Not used

Bit 2: Paper size selection priority for an A4 size fax message when A4/LT size paper is not available.

0: A3 has priority, 1: B4 has priority

Bits 3 to 7: Not used

6800D1(H) – User parameter switch 17 (SWUSR_11)

Bits 0 and 1: Not used

Bit 2: Inclusion of the “OK” button when a sequence of Quick dials is selected for broadcasting

0: Not needed, 1: Needed

Bits 3 to 6: Not used

Bit 7: Action when the user presses the “Start” key without an original when using on hook dial or an external telephone.

0: Displays “Cannot detect original size”

1: Receives an incoming fax message

6800D2(H) - User parameter switch 18 (SWUSR_12)

Bit 0: TTI date 0: Off, 1: On

Bit 1: TTI sender 0: Off, 1: On

Bit 2: TTI file number 0: Off, 1: On

Bit 3: TTI page number 0: Off, 1: On

Bit 4 to 7: Not used

6800D3(H) - User parameter switch 19 (SWUSR_13)

Bits 0 to 2: Not used

Bit 3: 90° image rotation during B5 portrait Tx

(This switch is not printed on the user parameter list.)

0: Off, 1: On

Bit 4: Reduction of sample images on reports to 50% in the main scan and sub-scan directions. (This switch is not printed on the user parameter list.)

0: Off, 1: On

Bit 5: Use of A5 size paper for reports

(This switch is not printed on the user parameter list.)

0: Off, 1: On

Bits 6 and 7: Not used

6800D4(H) to 6800D8 - User parameter switch 20 to 24 (SWUSR_14 to 18)

Bits 0 to 7: Not used

6800D9(H) - User parameter switch 25 (SWUSR_19)

Bits 0 to 3: Not used

Bit 4: RDS operation 0: Not acceptable

1: Acceptable for the limit specified by system switch 03

Note: This bit is only effective when RDS operation can be selected by the user.

Bits 5 and 6: Not used

Bit 7: Daylight saving time 0: Disabled, 1: Enabled

6800DA(H) - User parameter switch 26 (SWUSR_1A)

(This switch is not printed on the user parameter list.)

Bit 0: Not used

Bit 1: Dialing type 0: Pulse dialing (10 pps), 1: Tone (DTMF) dialing

Bits 2 to 7: Not used

6800DB(H) - User parameter switch 27 (SWUSR_1B)

PSTN access code from behind a PABX

(This switch is not printed on the user parameter list.)

Access number	Hex value to program (BCD)
0	F0
↓	↓
0	F0
00	00
↓	↓
99	99

6800DC(H) to 6800DF - User parameter switch 28 to 31 (SWUSR_1C to 1F)

Bits 0 to 7: Not used

680110 to 68011E(H) - Service station's fax number (Service mode 13)

SERVICE RAM ADDRESSES

68012E to 68013C(H) - Own fax number (PSTN)

680188 to 680119B(H) - RTI (Max. 20 characters - ASCII) - See the following note.

6801B0 to 6801EF(H) - TTI 1 (Max. 64 characters - ASCII) - See the following

680230 to 680243(H) - CSI (Max. 20 characters - ASCII)

68026C(H) - Number of CSI characters (Hex)

If the number of characters is less than the maximum (20 for RTI, 64 for TTI), add a stop code (FF[H]) after the last character.

680270(H) - ID code (low - Hex)

680271(H) - ID code (high - Hex)

680280 to 680287(H) - Last power off time (Read only)

680280(H) - 01(H) - 24-hour clock, 00(H) - 12-hour clock (AM), 02(H) - 12-hour clock (PM)

680281(H) - Year (BCD)

680282(H) - Month (BCD)

680283(H) - Day (BCD)

680284(H) - Hour

680285(H) - Minute

680286(H) - Second

680287(H) - 00: Monday, 01: Tuesday, 02: Wednesday, , 06: Sunday

680314 to 680319(H) - Modem ROM version (Read only)

680314(H) - Part number (low)

680315(H) - Part number (high)

680316(H) - Control (low)

680317(H) - Control (high)

680318(H) - DSP (low)

680319(H) - DSP (high)

68039A(H) - Transmission monitor volume 00 - 07(H)

68039B(H) - Reception monitor volume 00 - 07(H)

68039C(H) - On-hook monitor volume 00 - 07(H)

68039D(H) - Dialing monitor volume 00 - 07(H)

68039E(H) - Buzzer volume 00 - 07(H)

6803A1 to 6803A5(H) - Periodic service call parameters

Parameters		Address (H)
Call interval: 01 through 15 month(s) (BCD) 00: Periodic service call disabled		6803A1
Date and time of the next call	Day: 01 through 31 (BCD)	6803A4
	Hour: 01 through 24 (BCD)	6803A5

6803AB to 6803AD(H) - Effective term of automatic service calls

Parameters	Address (H)
Year: last two digits of the year (BCD)	6803AB
Month: 01 through 12 (BCD)	6803AC
Day: 01 through 31 (BCD)	6803AD

680400 to 6804E0(H) - NCU parameters (Refer to section 4.3 for details)

680CC8 to 680CEF(H) - SC codes NOT for automatic service call

If the fax unit receives a copier engine SC code other than those programmed in these addresses, the fax unit sends an automatic service call report to the programmed service station.

Six SC codes have already been programmed at default, as shown in the table below. Fourteen more SC codes can be programmed, if required (if an address contains FF(H), a code is not programmed in it).

Program a SC code in four-digit BCD format as shown in the example below.

Example 1: SC code '192'

Address (High) - 01 (BCD)

Address (Low) - 92 (BCD)

Wildcard characters "a" or "A" can be used to specify a series of SC codes.

Example 2: SC code '900 to 999'

Address (High) – 09 (BCD)

Address (Low) – aa or AA (Hex)

Example 3: SC code '330 to 339'

Address (High) – 03 (BCD)

Address (Low) – 3a or 3A (Hex)

- Default settings -

High Address (H)	Data (BCD)	Low Address (L)	Data (BCD)	SC code
680DC8	01	680DC9	92	192
680DCA	09	680DCB	80	980
680DCC	09	680DCD	99	999
680DCE to 680DEE	FF(H)	680DCF to 680DEF	FF(H)	Not Programmed

687BCC to 687FCB(H) - Dedicated tx parameters for Quick Dial 01 - 32.

There are 32 bytes for each Quick Dial. Only the 23rd to 32nd bytes are used.

6884B2 to 6884BB(H) - Dedicated tx parameters for Quick 01

6884D2 to 6884DB(H) - Dedicated tx parameters for Quick 02

6884F2 to 6884FB(H) - Dedicated tx parameters for Quick 03



688892 to 68889B(H) - Dedicated tx parameters for Quick 32

SERVICE RAM ADDRESSES

687FCC to 688C4B(H) - Dedicated tx parameters for Speed Dial #00 - #99.

There are 32 bytes for each Speed Dial. Only the 23rd to 32nd bytes are used.

688BB2 to 688BBB(H) - Dedicated tx parameters for Speed #00

688BD2 to 688BDB(H) - Dedicated tx parameters for Speed #01

688BF2 to 688BFB(H) - Dedicated tx parameters for Speed #02



689812 to 68981B(H) - Dedicated tx parameters for Speed #99

69CA00 to 69CBFF(H) - Latest 64 error codes (Read only)

One error record consists of 8 bytes of data.

First error record start address – 69CA00(H)

Second error record start address – 69CA08(H)

Third error record start address – 69CA10(H)

:

64th error record start address – 69CBF8(H)

The format is as follows:

1st byte - Minute (BCD)

2nd byte - Hour (BCD)

3rd byte - Day (BCD)

4th byte - Month (BCD)

5th byte - Error code – low (BCD) [If the error code is 1-23, 23 is stored here.]

6th byte - Error code – high (BCD) [If the error code is 1-23, 01 is stored here.]

7th byte - Communication line (Hex)

PSTN: 00(H), PABX: 02(H), ISDN G3: 0C(H), ISDN G4: 0D(H)

8th byte - Not used

69E134 to 69E813(H) - Latest 20 error communication records (Read only)

One error communication record consists of 88 bytes. The format is as follows:

1st byte - Header

Bit 0: Communication result	0: OK, 1: NG
Bit 1: Document jam	1: Occurred
Bit 2: Power down	1: Occurred
Bit 3: Not used	
Bit 4: Technical data printout instead of personal codes	0: No, 1: Yes
Bit 5: Type of technical data	0: Rx level, 1: Measure of error rate
Bit 6: Error report	0: Not printed, 1: Printed
Bit 7: Data validity	0: Not valid, 1: Valid

2nd byte - Not used

3rd to 6th bytes - Date and time when the communication started

3rd byte - Month (BCD)

4th byte - Day (BCD)

5th byte - Hour (BCD)

6th byte - Minute (BCD)

7th and 8th bytes - Communication time

7th byte - Minutes (BCD)

8th byte - Seconds (BCD)

9th and 10th bytes - Number of pages transmitted or received

9th byte - Low byte (Hex)

10th byte - High byte (Hex)

11th and 12th bytes - Personal code or number of total/burst error lines

If bit 4 of the 1st byte is 0:

11th byte - Personal code (low - BCD)

12th byte - Personal code (high - BCD)

If bit 4 of the 1st byte is 1:

11th byte - Number of total error lines (Hex)

12th byte - Number of burst error lines (Hex)

13th byte - File number (low - Hex)

14th byte - File number (high - Hex)

15th and 16th bytes - Rx level or a measure of the error rate

If bit 5 of the 1st byte is 0:

15th byte - Rx level (low - Hex)

16th byte - Rx level (high - Hex)

If bit 4 of the 1st byte is 1:

15th byte - Measure of error rate (low - Hex)

16th byte - Measure of error rate (high - Hex)

SERVICE RAM ADDRESSES

17th byte - Final modem rate

Bits 0 to 3: Final modem speed

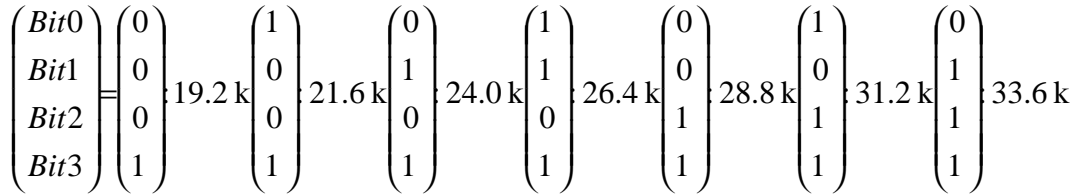
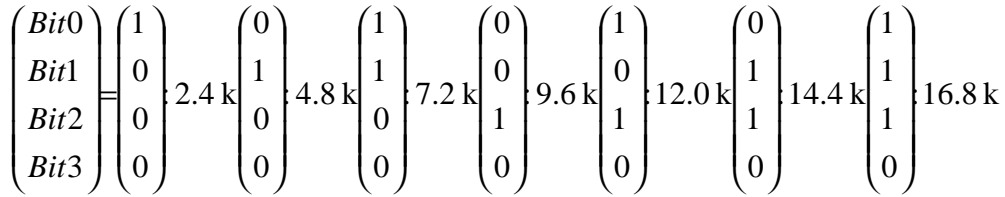

Bits 4 to 6: Final modem type

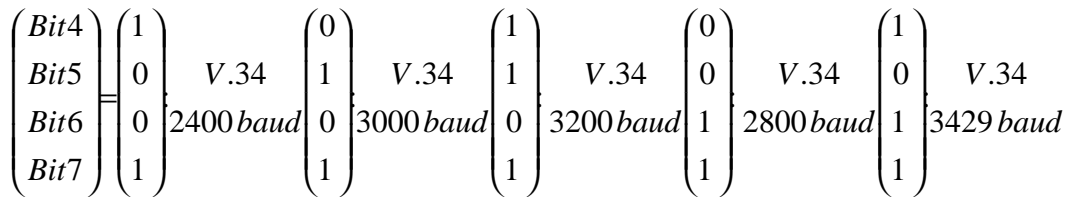
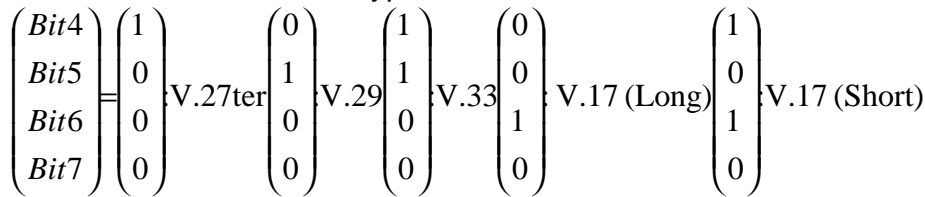

18th to 20th byte - Not used

21st to 44th byte - Remote terminal's ID (RTI, TSI or CSI) (ASCII)

45th byte - Communication mode #1

Bits 0 - 1: Network

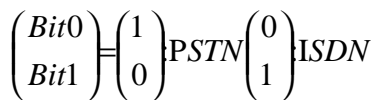

Bit 2: Communication protocol 0: G3, 1: G4

Bit 3: ECM 0: Off, 1: On

Bits 4 to 7: Communication mode used

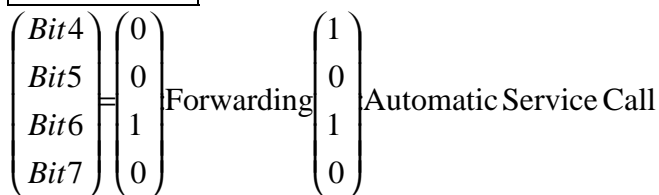
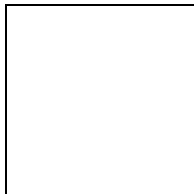

46th byte - Communication mode #2

Bit 0: Tx or Rx	0: Tx, 1: Rx
Bit 1: Reduction during Tx	0: Not reduced, 1: Reduced
Bit 2: Batch transmission	0: Not used, 1: Used
Bit 3: Send later transmission	0: Not used, 1: Used
Bit 4: Transmission from	0: ADF, 1: Memory
Bits 5 to 7: Not used	

47th byte - Not used

48th byte - Number of errors during communication (Hex)

49th to 52nd byte - 1st error code and page number where the error occurred

49th byte - Page number where the error occurred (low - Hex)

50th byte - Page number where the error occurred (high - Hex)

51st byte - Error code (low - BCD)

52nd byte - Error code (high - BCD)

53rd to 56th byte - 2nd error code and page number where the error occurred

57th to 60th byte - 3rd error code and page number where the error occurred

61st to 64th byte - 4th error code and page number where the error occurred

65th to 68th byte - 5th error code and page number where the error occurred

69th to 72nd byte - 6th error code and page number where the error occurred

73rd to 76th byte - 7th error code and page number where the error occurred

77th to 80th byte - 8th error code and page number where the error occurred

81st to 84th byte - 9th error code and page number where the error occurred

85th to 88th byte - 10th error code and page number where the error occurred

DETAILED SECTION DESCRIPTIONS

6. DETAILED SECTION DESCRIPTIONS

6.1 OPERATION DUMP LIST

The dump list contains a record of the actual operations performed by the operator (including keys that were pressed) as well as when these operations were performed. Refer to the sample below.

* * * OPERATION MAILBOX(R) DUMP (Date and Time) * * *				P.#
	MSG	CLASS	CODE	
0001	01:APIP	02:STATUS	0D00:LowPower Mode Out	
0002	01:APIP	02:STATUS	0004:Rel Req	
0003	01:APIP	02:STATUS	0004:Own Req	
0004	01:APIP	01:KEY CODE	0055:Onhook	
0005	01:APIP	01:KEY CODE	0022:2	
0006	01:APIP	01:KEY CODE	0025:5	
0007	01:APIP	01:KEY CODE	0023:3	
0008	01:APIP	01:KEY CODE	0001:Start	
0009	7E:TIME	XX:day	XXXX:hour:min	
:	:	:	:	Code Number and Meaning
:	:	:	:	Class
:	:	:	:	Message
:	:	:	:	Number
:	:	:	:	
:	:	:	:	
:	:	:	:	

APIP indicates an operator action, which is subdivided into either KEY CODE (key operation) or STATUS (non-key operation). The operation itself is then described in the column to the far right. If the Start key was pressed, the following line starts with 'TIME', and the day and time of the operation are then shown in the middle and far right columns.

This feature was developed in order to provide an accurate record (evidence) of the actual operations performed by the user, which may be used to clear up cases where the machine had apparently performed a wrong operation even though the correct keys were pressed.

This list can be printed out with fax service mode 15: History (➔ 5. SERVICE TABLES).

6.2 PCBS

6.2.1 FCU

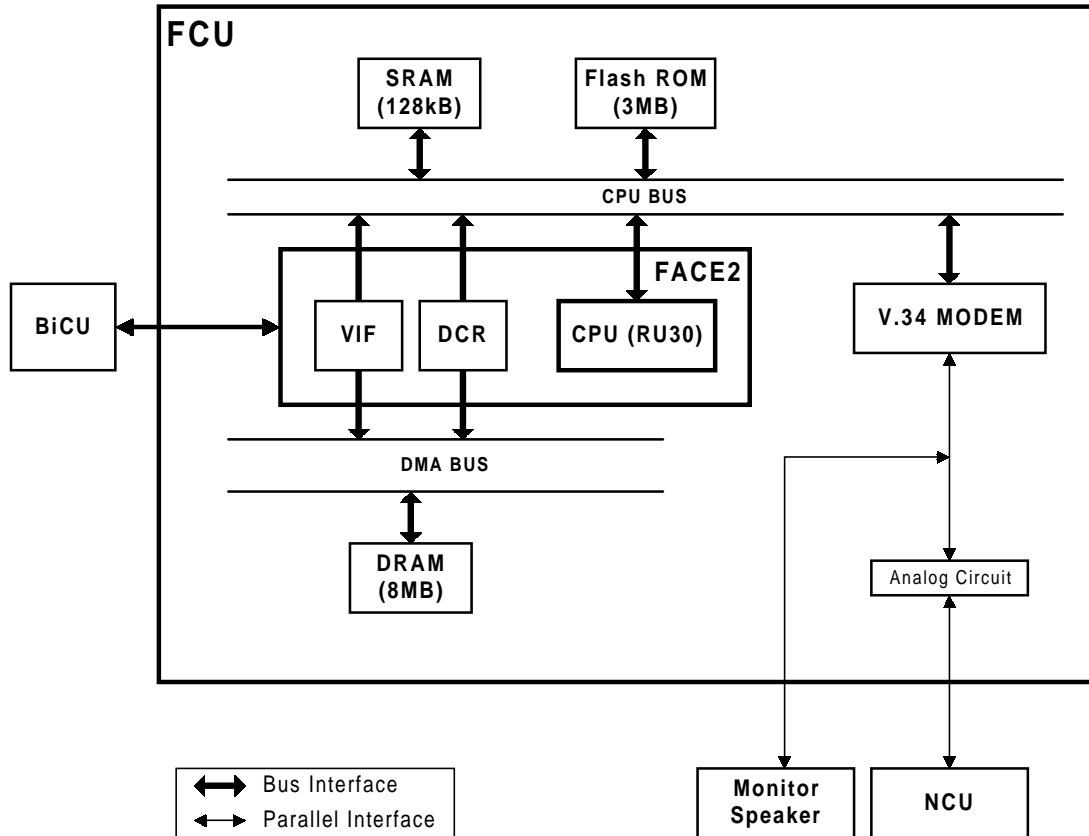

The FCU (Facsimile Control Unit) controls fax communications, the video interface to the base copier's engine, and all the fax options.

FACE2

- CPU
- Data compression and reconstruction (DCR)
- DMA control
- Clock generation
- DRAM backup control
- Ringing signal/tone detection
- Video and command interface to the BiCU (VIF)

Modem (Rockwell R288F)

- V.34, V33, V17, V.29, V.27ter, V.21, and V.8

ROM

- 3 MB (16 Mbit) flash ROM for system software storage

DRAM

- The 8 MB of DRAM is shared between SAF memory, ECM buffer, page memory, working memory, line buffer, and so on.
- The SAF memory (2MB) is backed up by a rechargeable battery.

SRAM

- The 128 KB SRAM for system and user parameter storage is backed up by a lithium battery.

Switches

Item	Description
TB1	Used to specify the country setting for Europe/Asia (see NCU Europe/Asia)
TB3	Switches the DRAM backup battery on/off

6.1.2 NCU (US)

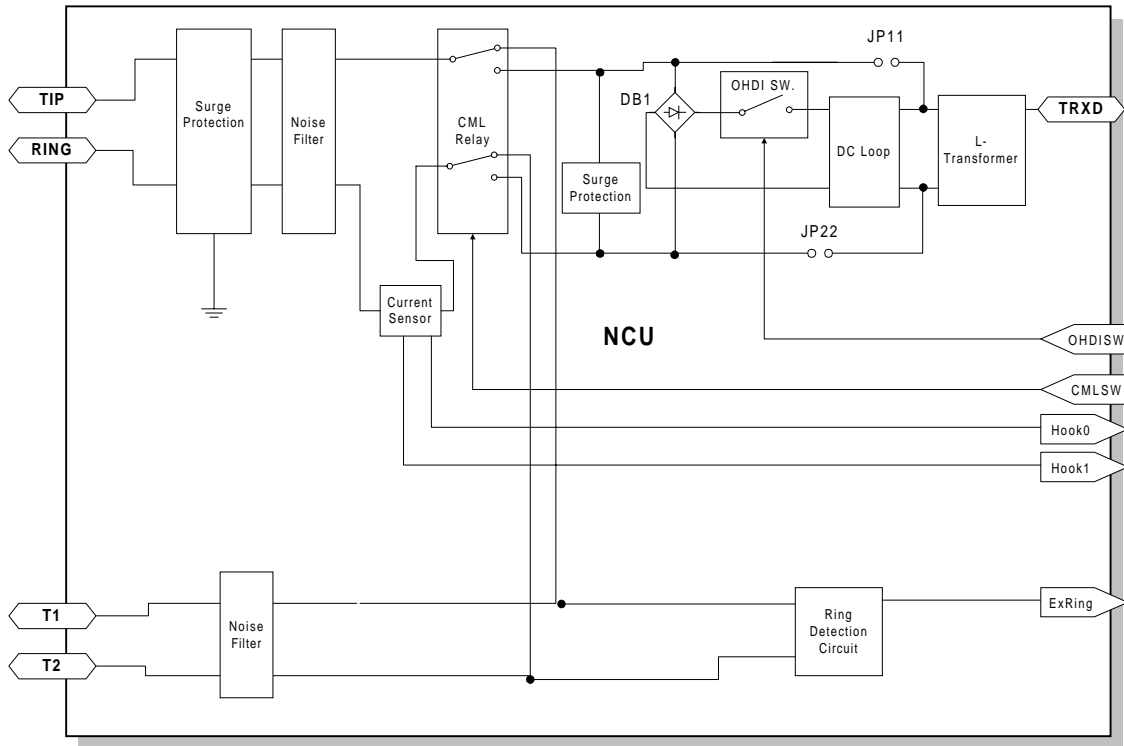

Jumpers

Item	Description
JP11	These jumpers should be shorted when the machine is connected to a dry line.
JP22	
DB1	Also remove DB1 when the machine is connected to a dry line.

6.1.3 NCU (EUROPE/ASIA)

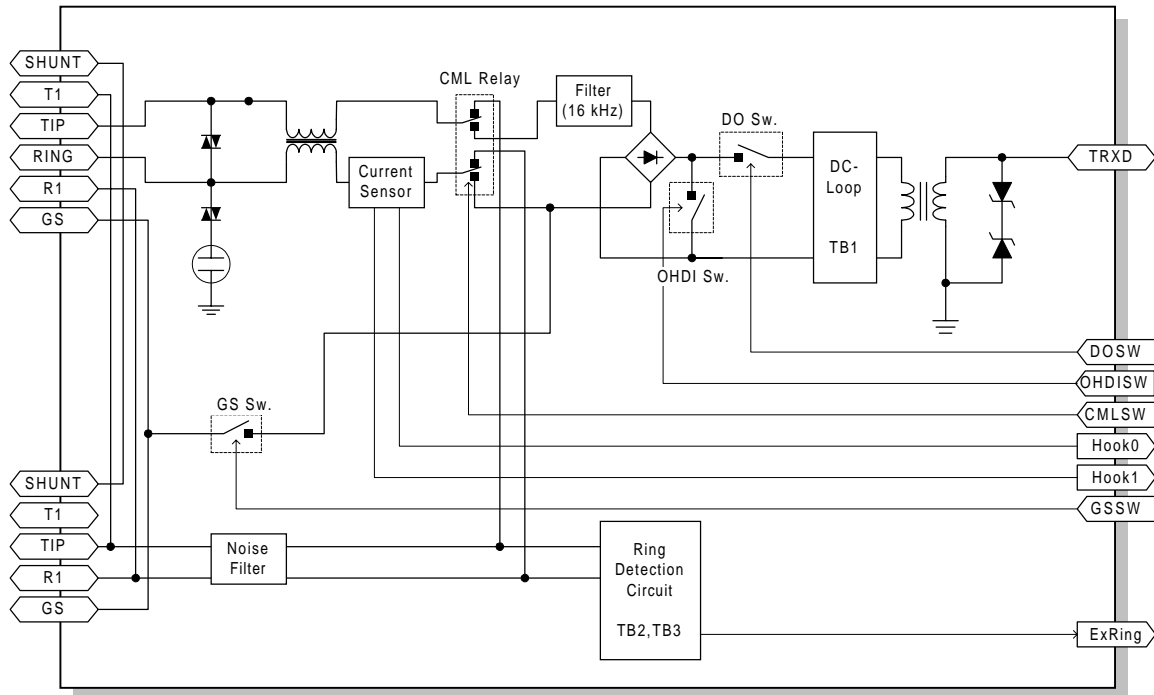

Fat Unit B404

Individual Switch Settings:

Country	FCU		NCU	
	TB1	TB2	TB2	TB3
CTR21, Israel	2-5	2-3	OFF	ON
Poland	2-5	2-3	ON	OFF
Australia	2-5	1-2	OFF	ON
New Zealand	2-5	1-2	ON	OFF
Malaysia, South Africa	3-4	1-2	OFF	ON
Asia and others	3-4	1-2	ON	OFF

NOTE: It is necessary to change the country code in both system switch 0F and NCU parameter.

CTR21 (Common Technical Regulation 21):

France, Germany, UK, Italy, Austria, Belgium, Denmark, Finland, Ireland, Norway, Sweden, Switzerland, Portugal, Holland, Spain, Israel, Greece

SPECIFICATIONS

SPECIFICATIONS

1. GENERAL SPECIFICATIONS

Type

Desktop type transceiver

Circuit

PSTN, PABX

Connection

Direct couple

Original Size (Book)

Maximum Length: 432 mm [17 ins]

Maximum Width: 297 mm [11.7 ins]

Original Size (ADF)

Length: 128 - 1200 mm [5.0 – 47.2 ins]

Width: 105 - 297 mm [4.1 - 11.7 ins]

Scanning Method

Flat bed, with CCD

Scan Width

210 mm [8.3 ins] \pm 1% (A4)

216 mm [8.5 ins] \pm 1% (8.5" x 11")

256 mm [10.1 ins] \pm 1% (B4)

279 mm [11.0 ins] \pm 1% (11" x 17")

297 mm [11.7 ins] \pm 1% (A3)

Resolutions

8 x 3.85 lines/mm

8 x 7.7 lines/mm

8 x 15.4 lines/mm

200 x 100 dpi

200 x 200 dpi

Memory Capacity

ECM: 128 Kbytes

SAF:

Standard: 2 Mbytes (160 pages)

Maximum: 4 Mbytes (by bit switch adjustment; fine mode becomes unavailable)

Measured using an ITU-T #1 test document (Slerexe letter)

Compression

MH, MR, MMR

SAF storage for memory tx: MMR and/or raw data

Protocol

Group 3 with ECM

Modulation

V.34, V.33, V.17 (TCM), V.29 (QAM), V.27ter (PHM), V.8, V.21 (FM)

Data Rate (bps)

G3:

33600/31200/28800/26400/24000/21600/
19200/16800/14400/12000/9600/7200/4800
/2400, Automatic fallback

I/O Rate

With ECM: 0 ms/line

Without ECM: 2.5, 5, 10, 20, or 40 ms/line

Transmission Time

G3: 3 s at 28800 bps; Measured with G3 ECM using memory for an ITU-T #1 test document (Slerexe letter) at 8 x 3.85 l/mm resolution

2. FEATURES

2.1 FEATURES LIST

KEY:

O = Used, X = Not Used

Video Processing Features	
Automatic image density selection	O
Contrast	O
Halftone (Basic & Error Diffusion)	O
JBIG compression	X
MTF	O
Reduction before tx	O
Scanning Resolution – Standard	O
Scanning Resolution – Detail	O
Scanning Resolution – Fine	O
Scanning Resolution – Superfine	X
Smoothing to 400 x 400 dpi when printing	O

Communication Features – Automatic	
Automatic fallback	O
Automatic redialing (Memory tx only)	O
Dual Access	O
Length Reduction	O
Resolutions available for reception	
Detail	O
Fine	O
Superfine	X
Substitute reception	O
V34 communication	O

Communication Features – User Selectable	
90° Image Rotation before tx	O
Action as a transfer broadcaster	X
AI Redial (last ten numbers)	O
Answering machine interface	X
Authorized Reception	O
Auto Document	X
Automatic dialing (pulse or DTMF)	O



Communication Features – User Selectable	
Automatic Voice Message	X
Batch Transmission	O
Book Original tx	X
Broadcasting	O
Chain Dialing	O
Communication Record Display	O
Confidential ID Override	X
Confidential Reception	X
Confidential Transmission	X
Direct Fax Number Entry	O
Economy Transmission	X
Fax on demand	X
Forwarding	O
Free Polling	O
Groups (Standard: 9 groups)	O
Hold	X
ID Transmission	X
Immediate Redialing	O
Immediate Transmission	O
ISDN	X
Keystroke Programs	X
Memory transmission	O
Multi-step Transfer	X
Non-standard original size transmission	O
OMR	X
On Hook Dial	O
Ordering Toner	X
Page Count	O
Page separation mark	O
Parallel memory transmission	O
Partial Image Area Scanning	X
Personal Codes	O
Personal Codes with Conf. ID	X
Polling Reception	O
Polling Transmission	X
Polling tx file lifetime in the SAF	X
Quick Dial (Standard: 32 stations)	O
Reception modes (Fax, Tel)	O
Remote control features	X
Remote Transfer	X
Restricted Access	O

SPECIFICATIONS

Communication Features – User Selectable	
Send Later	O
SEP/SUB/PWD/SID	O
Silent ringing detection	X
Specified Image area	X
Speed Dial (100 stations)	O
Stamp	O
Telephone Directory	O
Tonal Signal Transmission	O
Transfer Request	O
Transmission Deadline (TRD)	X
Turnaround Polling	X
Two in one	X
Voice Request (immed. tx only)	X

Communication Features - Service Selectable	
AI Short Protocol	O
Auto-reduction override option	O
Busy tone detection	O
Cable Equalizer	O
Closed Network	X
Continuous Polling Reception	X
Dedicated tx parameters	O
ECM	O
EFC	X
Inch-mm conversion before tx	O
Length Reduction	O
Page retransmission times	O
Protection against wrong connection	O
Short Preamble	X

Other User Features	
Area code prefix	X
Center mark	O
Checkered mark	O
Clearing a memory file	O
Clearing a polling file	X
Clock	O
Confidential ID	X
Counters	O
Daylight Saving Time	O
Destination Check	X
Energy Saver	O

Other User Features	
File Retention Time	X
File Retransmission	X
Function Programs (F1 – F3)	O
Hard Disk Filing System	X
ID Code	O
Label Insertion ("To xxx")	O
Language Selection	O
Memory Lock	X
Multi Sort Document Reception	X
Own telephone number	O
Print density control	X
RDS on/off	O
Reception Mode Switching Timer	X
Reception time printing	O
Remaining memory indicator	O
Reverse Order Printing	X
RTI, TTI, CSI	O
Service Report Transmission	O
Speaker volume control	O
Specified Cassette Selection	X
Toner Saving Mode	X
TTI on/off	O
User Function Keys (3 keys)	O
User Parameters	O
Wild Cards	O

Fax Unit B404

SPECIFICATIONS

Reports - Automatic	
Charge Control Report	X
Communication Failure Report	O
Confidential File Report	X
Error Report	O
Fax On Demand Report	X
File Clear Report	X
File Reserve Report	O
Journal	O
Polling Result Report	O
Power Failure Report	O
Transfer Result Report	X
Transmission Result Report	O

Reports - User-initiated	
Authorized Reception List	O
Charge Control Report	X
File List	O
Forwarding List	O
Group List	O
Hard Disk File List	X
Journal	O
Personal Code List	O
Program List	X
Quick Dial Label	O
Quick Dial List	O
Specified Cassette Selection List	X
Speed Dial List	O
Transmission Status Report	X
User Function List	X
User Parameter List	O

Service Mode Features	
Back-to-back test	X
Bit switch programming	O
Cable equalizer	O
Comm. parameter display	O
Counter check	SP mode
Country code	O
DTMF tone test	O
Echo countermeasure	O
Effective term of service calls	O
Error code display	O
Excessive jam alarm	O
File Transfer (all files)	O

Service Mode Features	
LCD contrast adjustment	O
Line error mark	O
Memory file printout (all files)	O
Modem Software Download	X
Modem test (including V.34/V.8)	O
NCU parameters	O
Periodic service call	O
PM Call	X
Printing all communication records kept in memory	O
Protocol dump list	O
RAM display/rewrite	O
RAM dump	O
RAM test	O
RDS	
- RAM read/write	O
- Dial data transfer (Quick/Speed)	O
- Software transfer	O
Ringer test	O
ROM version display (FCU)	SP mode
Serial number	O
Service monitor report	O
Service station number	O
Software Download	O
SRAM data backup/restore	O
System parameter list	O
Technical data on the Journal	O

2.2 CAPABILITIES OF PROGRAMMABLE ITEMS

The following table shows the capabilities of each programmable items.

Item	Numbers
Maximum number of memory files	200
Maximum number of destinations per file	100
Maximum number of pages overall	400
Number of Quick Dials	32
Number of Speed Dials	100
Number of Groups	9
Maximum number of destinations dialed from the ten-key pad overall	100
Maximum number of communication records for the Journal stored in the memory	100
Maximum number of user function keys	3
Maximum number of personal codes	20

3. OVERALL MACHINE CONTROL

3.1 SYSTEM CONTROL

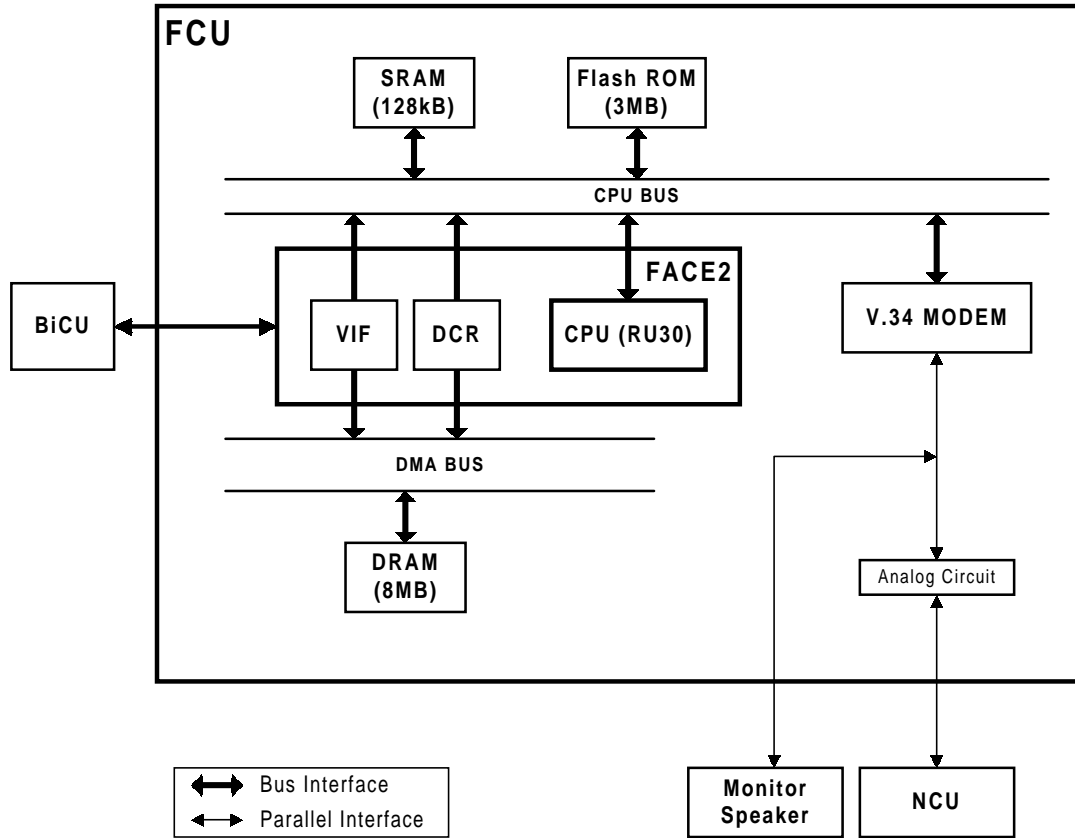

The basic fax unit consists of two PCBs: an FCU and an NCU. The FCU controls all the fax communications and fax features, in cooperation with the base copier's main board, the BiCU. The NCU switches the analog line between the fax unit and the external telephone.

3.2 POWER DISTRIBUTION

The FCU power is supplied from the PSU directly (+5V, -12V, +24V).

3.3 MEMORY BACK-UP

The system parameters and programmed items in the SRAM on the FCU is backed up by batteries (long-term backup), in case the base copier's main switch is turned off.

The SAF memory (DRAM) on the FCU is backed up by rechargeable batteries for 1 hour.

4. VIDEO DATA PATH

4.1 TRANSMISSION

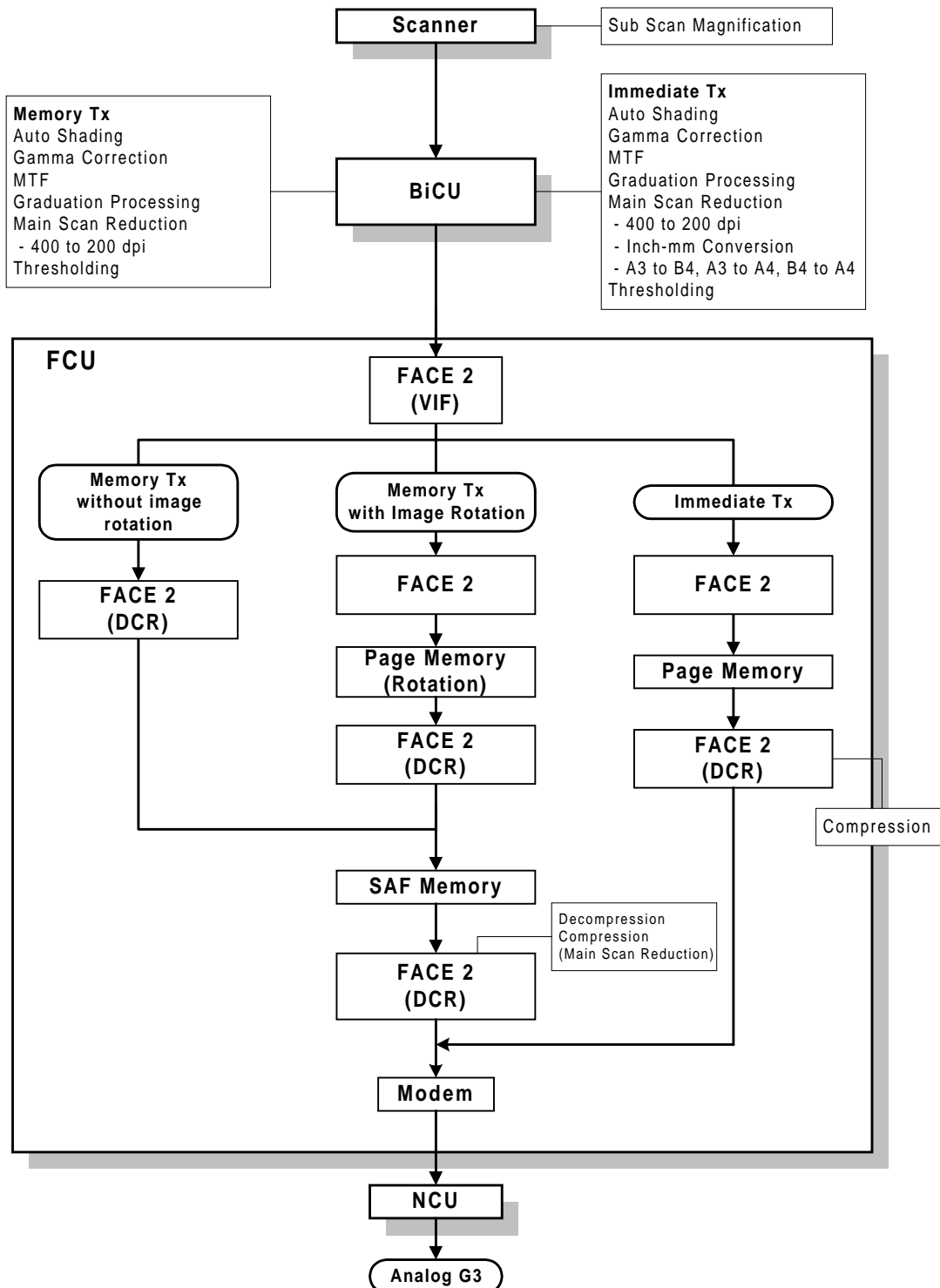

Fax Unit B404

SPECIFICATIONS

Memory Transmission and Parallel Memory Transmission

The base copier's scanner scans the original at the selected resolution in inch format. The BiCU processes the data and transfers it to the FCU.

NOTE: When scanning a fax original, the BiCU uses the MTF and thresholding parameter settings programmed in the fax unit's scanner bit switches, not the copier's SP modes.

Then, the FCU converts the data to mm format, and compresses the data in MMR or raw format to store it in the SAF memory. If image rotation is possible, the image is rotated in page memory before compression.

At the time of transmission, the FCU decompresses the stored data, then re-compresses and/or reduces the data if necessary for transmission. The NCU transmits the data to the line.

Immediate Transmission

The base copier's scanner scans the original at the resolution agreed with the receiving terminal. The BiCU video processes the data and transfers it to the FCU.

NOTE: When scanning a fax original, the BiCU uses the MTF and thresholding parameter settings programmed in the fax unit's scanner bit switches, not the copier's SP modes.

Then the FCU stores the data in page memory, and compresses the data for transmission. The NCU transmits the data to the line.

4.2 RECEPTION

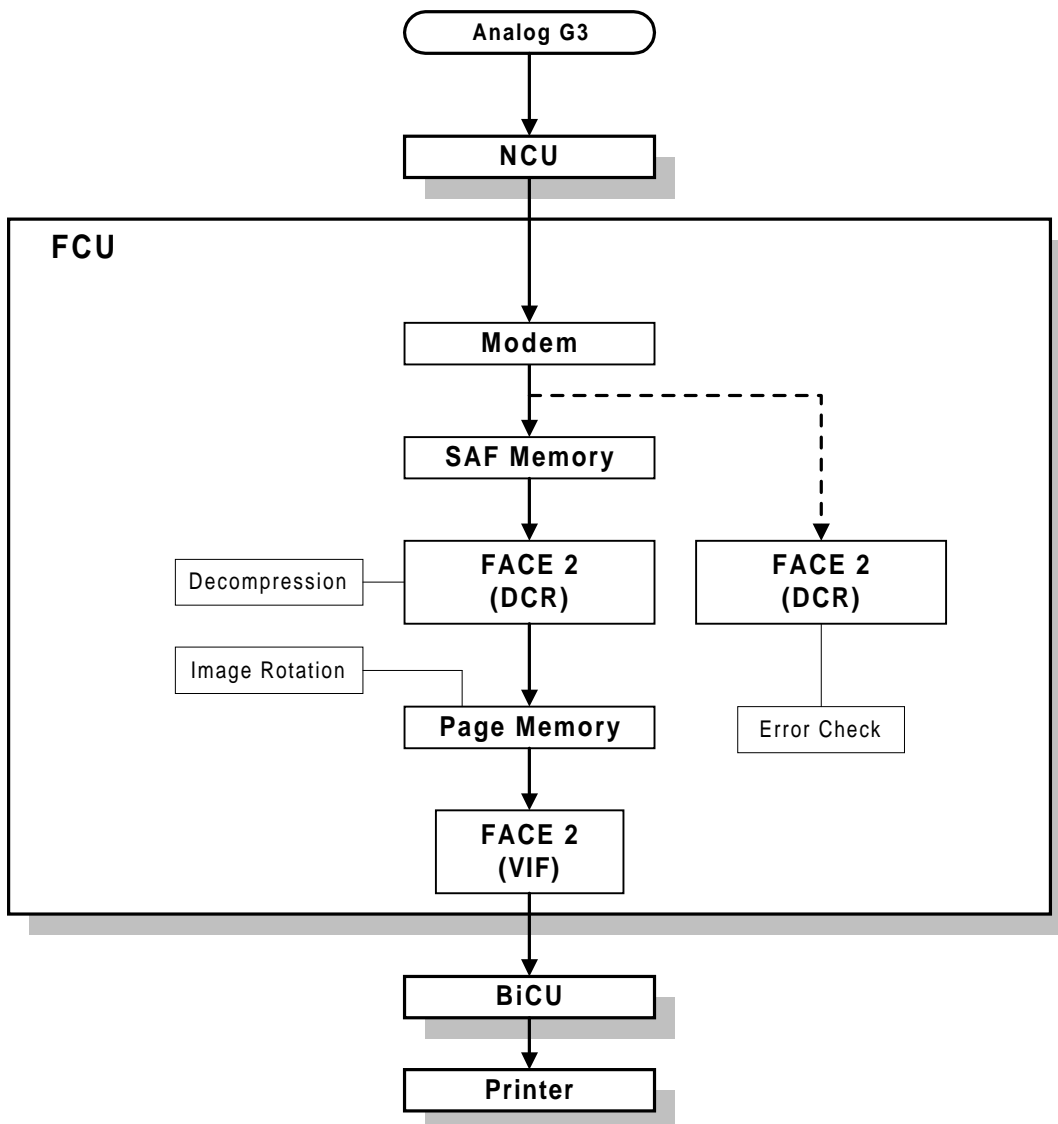

Fax Unit B404

First, the FCU stores the data from an analog line to the SAF memory. (The data goes in parallel to the FACE2, and is checked for error lines/frames.)

The FCU then decompresses the data and transfers it to page memory. If image rotation is possible, the image is rotated in the page memory. The data is then transferred to the BiCU.

SPECIFICATIONS

5. MACHINE CONFIGURATION

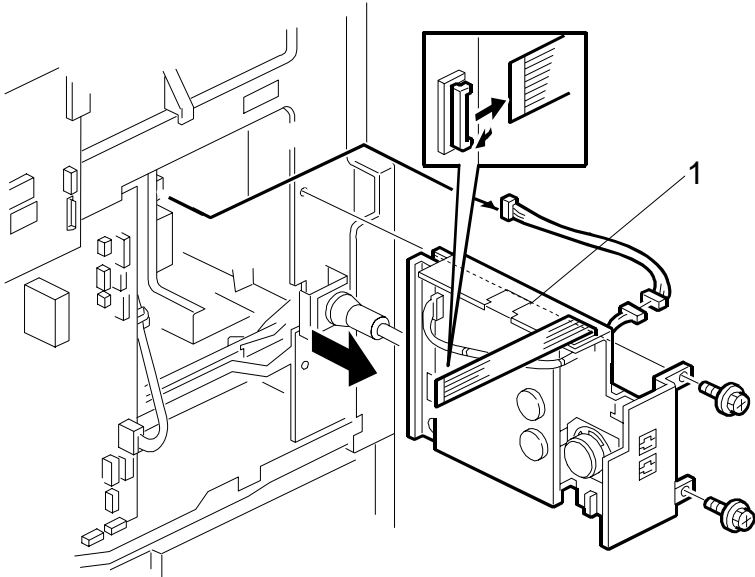

Item	Machine Code	No.	Remarks
Fax Option Type 1018	B404	1	
Handset Type 1018	B433	-	

FIRMWARE HISTORY

⇒ FIRMWARE HISTORY

1. FIRMWARE MODIFICATION HISTORY

- Please check the <http://tsc.riohcorp.com> website for current firmware downloads.
- Engine firmware modification history information is provided in "Section 4.5 – Firmware Modification History" of the B039/B040/B043 Service Manual.

B404 FIRMWARE MODIFICATION HISTORY			
DESCRIPTION OF MODIFICATION	FIRMWARE LEVEL	SERIAL NUMBER	FIRMWARE VERSION
1st Mass Production	B4045582B	1st Mass Production	01.12.00
<p>Nothing is displayed in the Dedicated Transmission Parameter screen when Finnish has been selected as the display language.</p> <p>The colon (":") is not displayed between the switch number and bit string for User Parameter SW 18 onward.</p> <p>Titles are not listed in the Power Failure Report (e.g. File, Time, Mode).</p> <p>When system switch 1E bit 2 (RTI/CSI display priority) = 1 (CSI), the machine displays "°" at the end of the other terminal's CSI. e.g. +813123456789°</p>	B4045582C	June '01 Production	03.06.00
<p>With French set as the display language, the following line is displayed twice if an undefined character is entered for a Speed Dial search: Annu. Tel.: [A] < > /OK. (Normally, a 'not found'-type error message should appear on the 2nd line).</p> <p>In some cases, Substitute Reception files do not appear on the Power Failure Report.</p> <p>In some cases, part of the image data along the main scan direction is missing with A3 → B4 reduction Tx.</p> <p>The list print does not stop, even when the Clear/Stop key is pressed.</p> <p>The center mark is missing when printing out Quick Dial Labels.</p>	B4045582D	August '01 Production	04.00.00

Fax Unit B404

B404 FIRMWARE MODIFICATION HISTORY			
DESCRIPTION OF MODIFICATION	FIRMWARE LEVEL	SERIAL NUMBER	FIRMWARE VERSION
<p>The image in the area 3cm from the leading edge is sometimes printed again near the middle of the page.</p> <p>The wording for "Quick Dial Label" in the Czech display language has been corrected as follows: Incorrect: Štítek Blesk. Correct: Štítek Blesk .Vol.</p> <p>The wording for "Select Sender with" in the Danish display language has been corrected as follows: Incorrect: Vælg modtager Bladre Correct: Vælg sender med</p> <p>The wording for "Extension Outside" in the Dutch display language has been corrected as follows: Incorrect: Intern Buiten Correct: Intern Externe</p> <p>The wording for "Select Sender with" in the Norwegian display language has been corrected as follows: Incorrect: Velg mottaker Se igjen. Correct: Velg mottaker med</p>	B4045582E	Oct '01 Production	05.01.00
<p>If the machine receives an incoming MMR transmission following an interrupted non-ECM job, a blank page is sometimes printed out.</p> <p>ADDRESS appears on the Journal where DATE and TIME are normally written.</p>	B4045582F	March '01 Production	06.05.00